

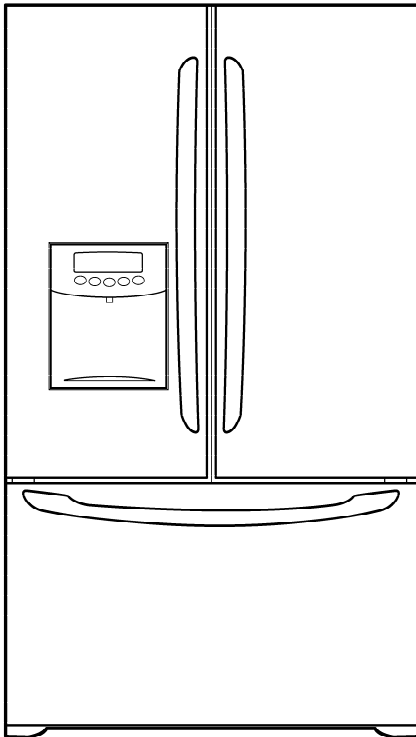

REFRIGERATOR SERVICE MANUAL

CAUTION
BEFORE SERVICING THE UNIT,
READ THE SAFETY PRECAUTIONS IN THIS MANUAL.



Model #s:

795.75542401
795.75549401
795.75544401
795.75543401
795.75546401
795.75552401
795.75559401
795.75554401
795.75553401
795.75556401

CONTENTS

SAFETY PRECAUTIONS	2
1. SPECIFICATIONS	3
2. PARTS IDENTIFICATION	4
3. DISASSEMBLY	5-7
DOOR	5-6
TO REMOVE THE DISPENSER	6
FAN AND FAN MOTOR	7
DEFROST CONTROL ASSEMBLY	7
LAMP	7
CONTROL BOX-REFRIGERATOR	7
MULTI DUCT	7
4. ADJUSTMENT	8-9
COMPRESSOR	8
PTC-STARTER	8
OLP (OVERLOAD PROTECTOR).....	9
TO REMOVE THE COVER PTC	9
5. CIRCUIT DIAGRAM	10
6. TROUBLESHOOTING	11-16
COMPRESSOR AND ELECTRIC COMPONENTS	11
PTC AND OLP	12
OTHER ELECTRICAL COMPONENTS	13
SERVICE DIAGNOSIS CHART	14
REFRIGERATION CYCLE	15-16
7. OPERATION PRINCIPLE & REPAIR METHOD OF ICEMAKER	17-20
8. DESCRIPTION OF FUNCTION & CIRCUIT OF MICOM	21-32
9. EXPLODED VIEW & REPLACEMENT PARTS LIST	33-

SAFETY PRECAUTIONS

Please read the following instructions before servicing your refrigerator.

1. Check the refrigerator for current leakage.
2. To prevent electric shock, unplug before servicing.
3. Always check line voltage and amperage.
4. Use standard electrical components.
5. Don't touch metal products in the freezer with wet hands. This may cause frostbite.
6. Prevent water from spilling onto electric elements or the machine parts.
7. Close the top door before opening the bottom door. Otherwise, you might hit your head when you stand up.
8. When tilting the refrigerator, remove any materials on the refrigerator, especially the thin plates (ex. glass shelf or books.)
9. When servicing the evaporator, wear cotton gloves. This is to prevent injuries from the sharp evaporator fins.
10. Service on the refrigerator should be performed by a qualified technician. Sealed system repair must be performed by a CFC certified technician.

1. SPECIFICATIONS

1-1 DISCONNECT POWER CORD BEFORE SERVICING IMPORTANT – RECONNECT ALL GROUNDING DEVICES

All parts of this appliance capable of conducting electrical current are grounded. If grounding wires, screws, straps, clips, nuts or washers used to complete a path to ground are removed for service, they must be returned to their original position and properly fastened.

1-2 IMPORTANT NOTICE

This information is intended for use by individuals possessing adequate backgrounds of electrical, electronic and mechanical experience. Any attempt to repair a major appliance may result in personal injury and property damage. The manufacturer or seller cannot be responsible for the interpretation of this information, nor can it assume any liability in connection with its use.

1-3 ELECTRICAL SPECIFICATIONS

Temperature Control (Position: MID)-6°F to +8°F
 Defrost Control7 hrs
 Defrost Thermostat46°F
 Electrical Rating : 115VAC, 60Hz.....1-5 A
 Maximum Current Leakage.....0.5 mA
 Maximum Ground Path Resistance0.14 Ohms
 Energy Consumption21 cu.ft. 465 kWh/yr (Energy Star)
25 cu.ft. 499 kWh/yr (Energy Star)

1-4 NO LOAD PERFORMANCE CONTROL POSITION: MID/MID

And Ambient of:70°F90°F
 Fresh Food, °F.....33°F to 41°F.....33°F to 41°F
 Frozen Food, °F.....-4°F to +4°F-4°F to +4°F
 Percent Running Time35%-45%50°F-70°F

1-5 REFRIGERATION SYSTEM

Minimum Compressor Capacity Vacuum 21 in.
 Minimum Equalized Pressure
 @ 70°F 49 PSIG
 @ 90°F 56 PSIG
 Refrigerant R134a 4.06 oz.
 Compressor 830 BTU/hr

1-6 INSTALLATION

Clearance must be provided at top, sides and rear of the refrigerator for air circulation.

AT TOP 1 in
 AT SIDES 1 in
 AT REAR 2 in

1-7 REPLACEMENT PARTS

Relay	6748C-0004D
Overload	6750C-0005P
Defrost Thermostat	6615JB2005H
Defrost Heater	5300JK1005D
Evaporator Fan Motor	4681JK1004A
Capacitor	0CZZJB2012G
Compressor (Hi-Side)	2521C-A5719
Evaporator (Lo-Side)	5421JJ0006A
	*5421JJ0007A
Condenser	5403JJ1004B
Dryer	5851JA2002P
Condenser Fan Motor	4681JK1001B
Temperature Control	6871JB1310A
Main Control.....	6871JB1280A

1-8 AIR FLOW / CIRCULATION D' AIR

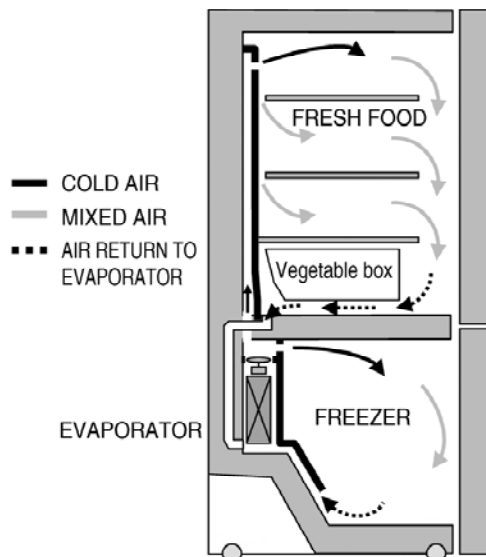
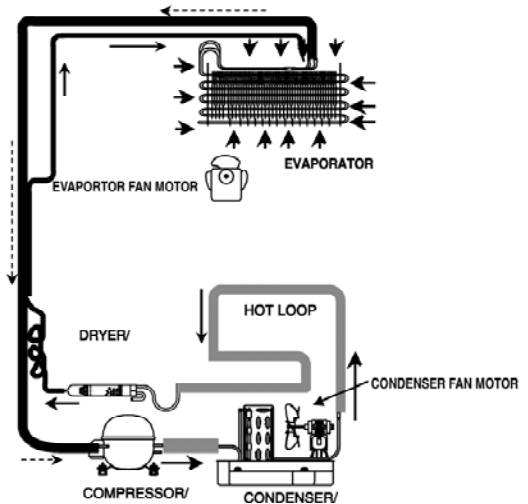

2. PARTS IDENTIFICATION

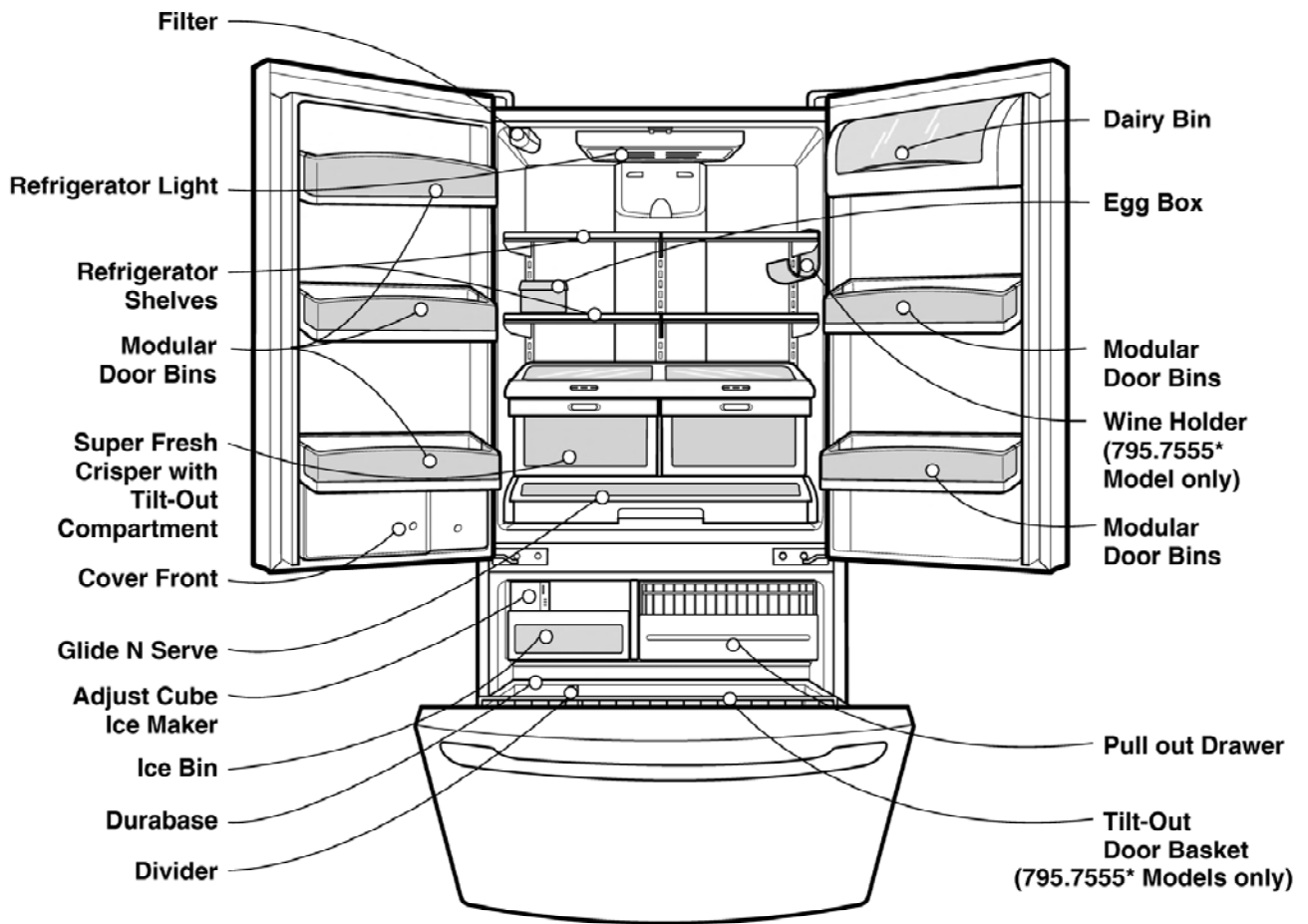

3. DISASSEMBLY

3-1 REMOVING AND REPLACING REFRIGERATOR DOORS

● Removing Refrigerator Door

▲ **CAUTION:** Before you begin, unplug the refrigerator. Remove food and bins from doors.

▶ Left Door

1. Disconnect water supply tube by pushing back on the disconnect ring (4).
2. Open door. Loosen top hinge cover screw (1).
- Use flat tip screwdriver to pry back hooks on front underside of cover (3). Lift up cover.
3. Disconnect door switch wire harness (2). Remove cover.
4. Attach the tube on the door with door.
5. Pull out the tube.
6. Disconnect the three wire harnesses (5). Remove the grounding screw (6).
7. Rotate hinge lever (7) counterclockwise and remove. Lift top hinge (8) free of hinge lever latch (9).

▲ **CAUTION:** When lifting hinge free of latch, be careful that door does not fall forward.

8. Lift door up from middle hinge pin (10) and remove door.
9. Place door, inside facing up, down onto a non-scratching surface.

▶ Right Door

1. Open door. Loosen top hinge cover screw (1). Lift up cover (3).
2. Disconnect door switch wire harness (2). Remove cover.
3. Disconnect wire harness (5). Remove the grounding screw (6).
4. Rotate hinge lever (7) clockwise and remove. Lift top hinge (8) free of hinge lever latch (9).

▲ **CAUTION:** When lifting hinge free of latch, be careful that door does not fall forward.

5. Lift door up from middle hinge pin (10) and remove door.
6. Place door, inside facing up, down onto a non-scratching surface.

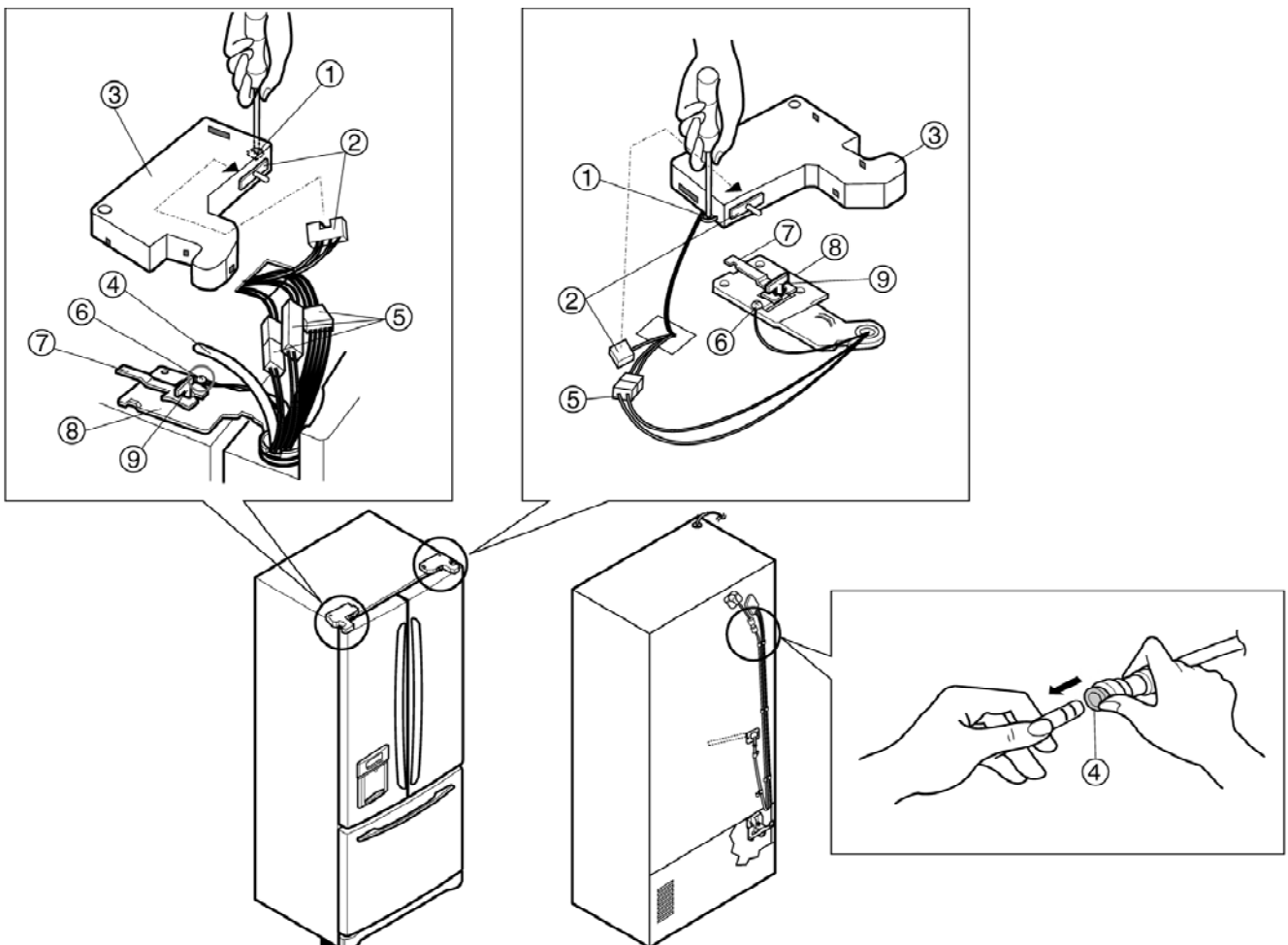

3-2 DOOR

● Door Gasket Removal

1. Remove door frame cover

Starting at top of cover and working down, snap cover out and away from door.

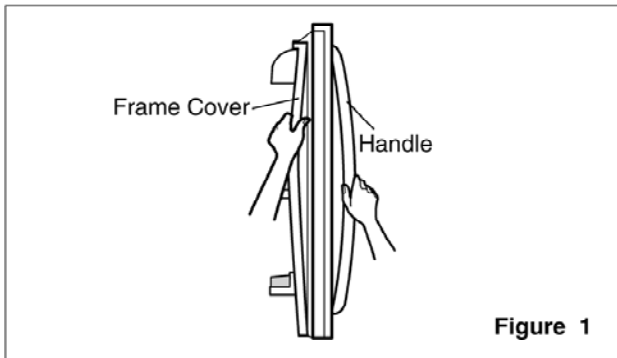

2. Remove gasket bracket clips

There are two clips on each door. Start bracket removal near one of the middle clips.

- 1) Pull gasket back to expose gasket bracket clip and door frame.
- 2) Insert a flat tip screwdriver into seam between gasket bracket and door frame and pry back until clips snaps out.
- 3) Continue prying back along seam until all clips snap out.

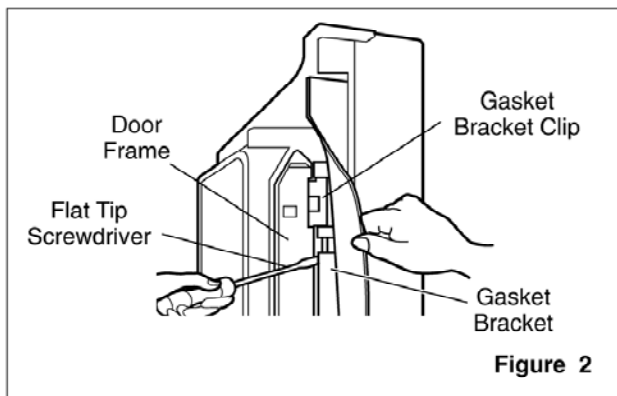

3. Remove gasket

Pull gasket free from gasket channel on the three remaining sides of door.

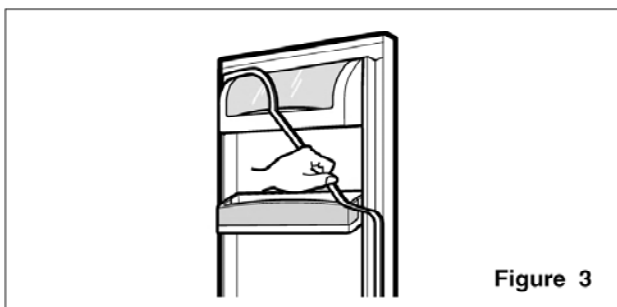

● Door Gasket Replacement

1. Insert gasket bracket clips

- 1) Insert gasket bracket edge beneath door frame edge.
- 2) Turn upper gasket bracket spring so that the spring ends are in the door channel.
- 3) Push in clip until you hear it snap securely into place.

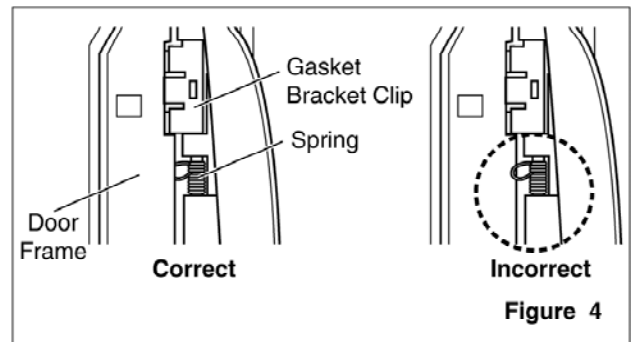

- 4) Push in remaining two clips until you hear each snap securely into place.

Note: Make sure that no part of gasket bracket edge protrudes from beneath door frame edge.

2. Insert gasket into channel

- 1) Snap gasket assembly into the door bracket.

<Inserting the Gasket Assembly into the Bracket Door>

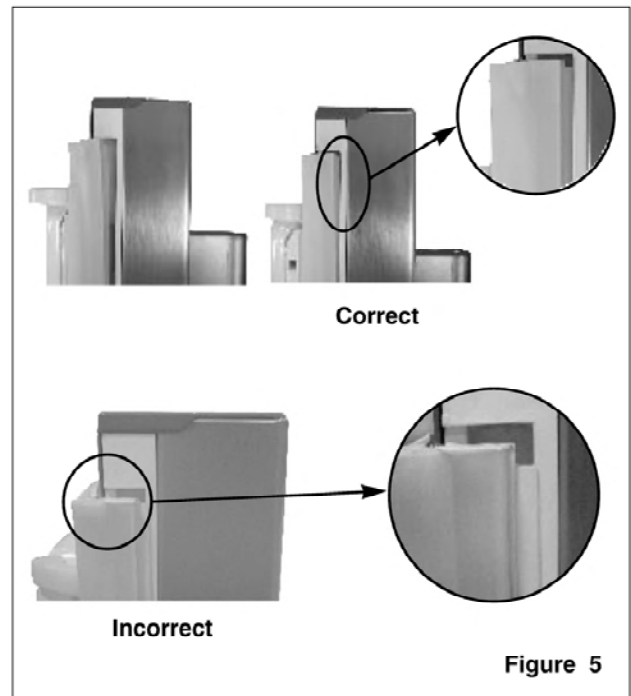

- 2) Press gasket into channels on the three remaining sides of door.

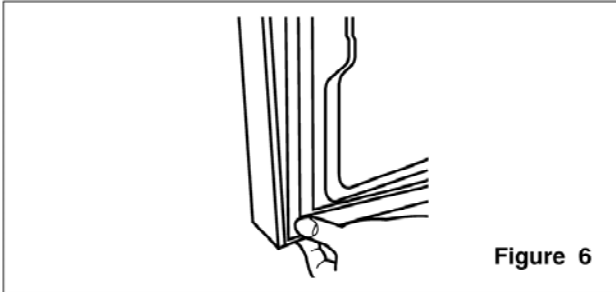

3. Replace door frame cover

Starting at top of cover and working down, snap cover back into door.

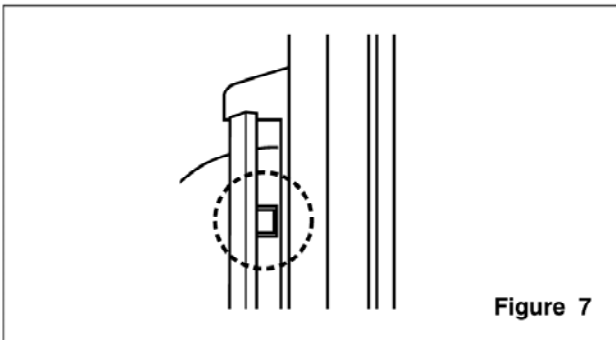

3-3 TO REMOVE THE DISPENSER

1. Use fiat tip screwdriver to pry back hooks on bottom underside of cover dispenser.

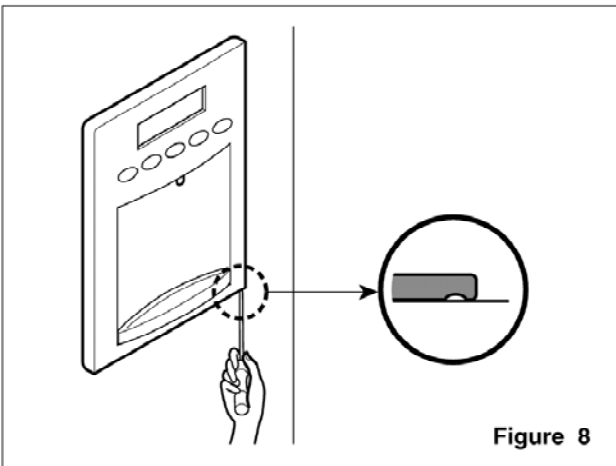

2. Pry off cover dispenser.

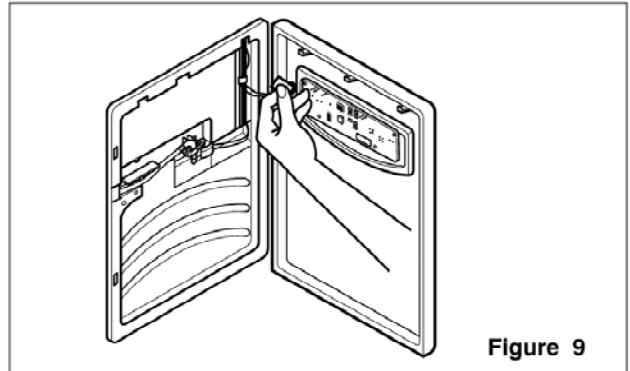

Disconnect wire harness.

3. Replace cover dispenser in opposite manner and order of removal.

3-4 DOOR ALIGNMENT

If the space between your doors is uneven, follow the instructions below to align the doors:

1. With one hand, lift up the door you want to raise at middle hinge.
2. With other hand, use pliers to insert snap ring as shown.
3. Insert additional snap rings until the doors are aligned. (Three snap rings are provided with unit.)

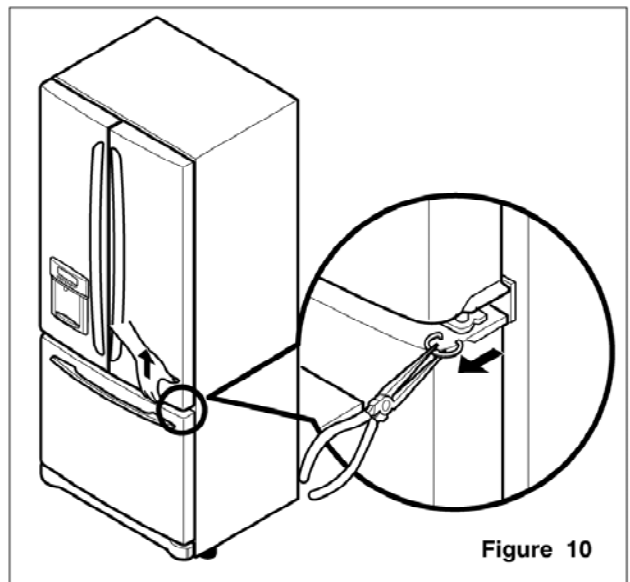

3-5 FAN AND FAN MOTOR

1. Remove the freezer shelf. (If your refrigerator has an icemaker, remove the icemaker first)
2. Remove the plastic guide for slides on left side by unscrewing phillips head screws.
3. Remove the grille by pulling it out and by loosening a screw.
4. Remove the Fan Motor assembly by loosening 2 screws and disassemble the shroud.
5. Pull out the fan and separate the Fan Motor and Bracket.

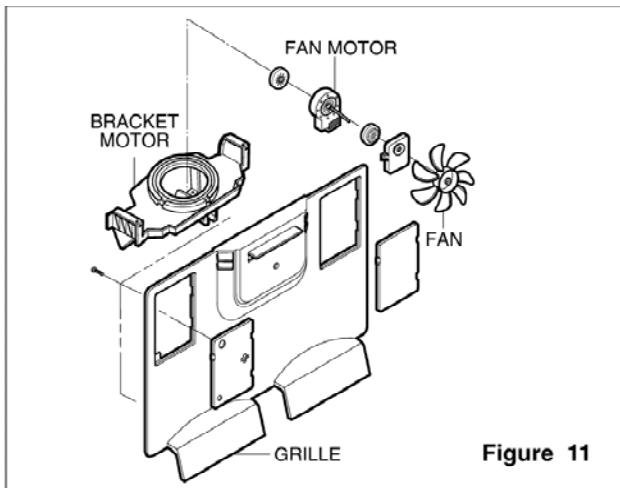

Figure 11

3-6 DEFROST CONTROL ASSEMBLY

Defrost Control assembly consists of Defrost Sensor and FUSE-M.

The Defrost Sensor works to defrost automatically. It is attached to the metal side of the Evaporator and senses its temperature. At 161.6°F(72°C), it turns the Defrost Heater off. Fuse-M is a safety device for preventing over-heating of the Heater when defrosting.

1. Pull out the grille assembly. (Figure 12)
2. Separate the connector with the Defrost Control assembly and replace the Defrost Control assembly after cutting the Tie Wrap. (Figure 13)

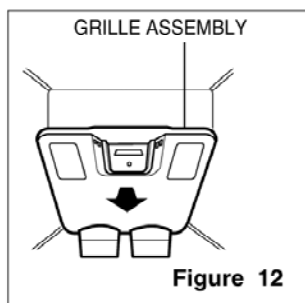

Figure 12

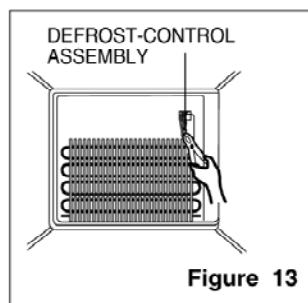

Figure 13

3-7 LAMP

3-7-1 Refrigerator Compartment Lamp

1. Unplug Refrigerator, or disconnect power at the circuit breaker.
2. If necessary, remove top shelf or shelves.
3. Using a flat instrument, gently pry the cover loose in the front as shown. Rotate downward to remove rear tabs.

4. Make sure the bulbs are cool to the touch. Turn bulbs counterclockwise to remove.
5. Assemble in reverse order by snapping the Lamp Cover in, engaging the rear tabs followed by the front tabs. (Max. 60 W-2EA)

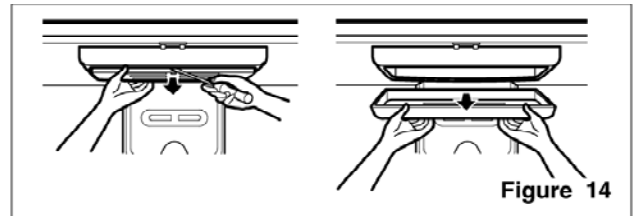

Figure 14

3-7-2 Freezer Compartment Lamp

1. Unplug refrigerator or disconnect power.
2. Reach behind light shield to remove bulb.
3. Replace bulb with a 60-watt appliance bulb.
4. Plug in refrigerator or reconnect power.

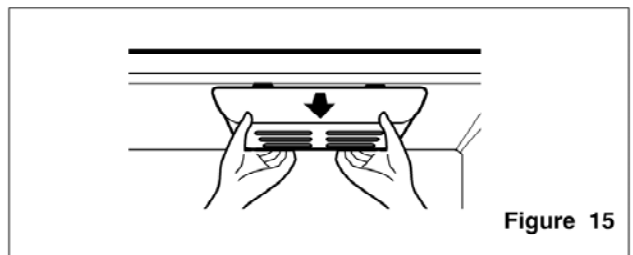

Figure 15

3-8 CONTROL BOX-REFRIGERATOR

1. First, remove all shelves in the refrigerator, then remove the Refrigerator control Box by loosening 2 screws.

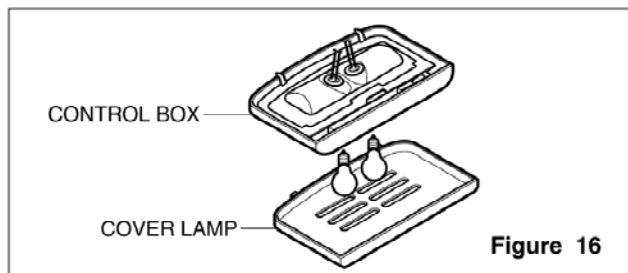

Figure 16

2. Remove the Refrigerator Control Box by pulling it downward.
3. Disconnect the lead wire on the right position and separate the lamp sockets.

3-9 MULTI DUCT

1. Remove an upper and lower Cap by using a flat screwdriver, and loosen 2 screws. (Figure 17)
2. Disconnect the lead wire on the bottom position.

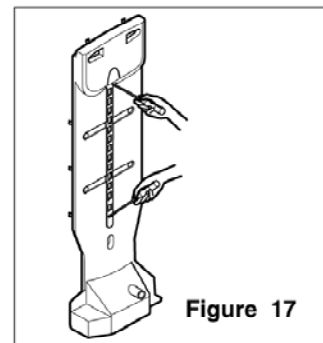

Figure 17

4. ADJUSTMENT

4-1 COMPRESSOR

4-1-1 Role

The compressor intakes low temperature and low pressure gas from the evaporator of the refrigerator and compresses this gas to high-temperature and high-pressure gas. It then delivers the gas to the condenser.

4-1-2 Composition

The compressor includes overload protection. The PTC starter and OLP (overload protector) are attached to the outside of the compressor. Since the compressor is manufactured to tolerances of 1 micron and is hermetically sealed in a dust and moisture-free environment, use extreme caution when performing repairs.

4-1-3 Note for Usage

- (1) Be careful not to allow over-voltage and over-current.
- (2) If compressor is dropped or handled carelessly, poor operation and noise may result.
- (3) Use proper electric components appropriate to the Particular Compressor in your product.
- (4) Keep Compressor dry.
If the Compressor gets wet (in the rain or a damp environment) and rust forms in the pin of the Hermetic Terminal, poor operation and contact may result.
- (5) When replacing the Compressor, be careful that dust, humidity, and soldering flux don't contaminate the inside of the compressor. Dust, humidity, and solder flux contaminate the cylinder and may cause noise, improper operation or even cause it to lock up.

4-2 PTC-STARTER

4-2-1 Composition of PTC-Starter

- (1) PTC (Positive Temperature Coefficient) is a no-contact semiconductor starting device which uses ceramic material consisting of BaTiO₃.
- (2) The higher the temperature is, the higher the resistance value. These features are used as a starting device for the Motor.

4-2-2 Role of PTC-Starter

- (1) The PTC is attached to the Sealed Compressor and is used for starting the Compressor Motor.
- (2) The compressor is a single-phase induction motor. The starting operation, the PTC allows current flow to both the start winding and main winding.

4-2-3 PTC-Applied Circuit Diagram

● Starting Method for the Motor

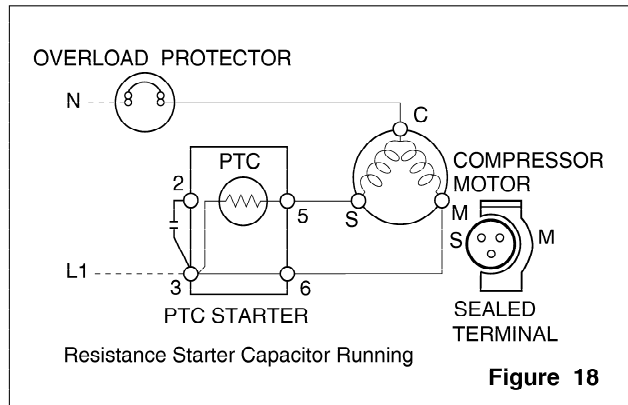

4-2-4 Motor Restarting and PTC Cooling

- (1) It requires approximately 5 minutes for the pressure to equalize before the compressor can restart.
- (2) The PTC device generates heat during operation. Therefore, it must be allowed to cool before the compressor can restart.

4-2-5 Relation of PTC-Starter and OLP

- (1) If the compressor attempts to restart before the PTC device is cooled, the PTC device will allow current to flow only to the main winding.
- (2) The OLP will open because of the over current condition. This same process will continue (3 to 5 times) when the compressor attempts to restart until the PTC device has cooled. The correct OLP must be properly attached to prevent damage to the compressor.

Parts may appear physically identical but could have different electrical ratings. Replace parts by part number and model number. Use only approved substitute parts.

4-2-6 Note for Using the PTC-Starter

- (1) Be careful not to allow over-voltage and over-current.
- (2) Do not drop or handle carelessly.
- (3) Keep away from any liquid.
If liquid such as oil or water enters the PTC, PTC materials may fail due to breakdown of their insulating capabilities.
- (4) If the exterior of the PTC is damaged, the resistance value may be altered. This can cause damage to the compressor and result in a no-start or hard-to-start condition.
- (5) Always use the PTC designed for the compressor and make sure it is properly attached to the compressor. Parts may appear physically identical but could have different electrical ratings. Replace parts by part number and model number. Use only approved substitute parts.

4-3 OLP (OVERLOAD PROTECTOR)

4-3-1 Definition of OLP

- (1) OLP (OVERLOAD PROTECTOR) is attached to the Compressor and protects the Motor by opening the circuit to the Motor if the temperature rises and activating the bimetal spring in the OLP.
- (2) When high current flows to the Compressor motor, the Bimetal works by heating the heater inside the OLP, and the OLP protects the Motor by cutting off the current flowing to the Compressor Motor.

4-3-2 Role of the OLP

- (1) The OLP is attached to the Sealed Compressor used for the Refrigerator. It prevents the Motor Coil from being started in the Compressor.
- (2) For normal operation of the OLP, do not turn the Adjust Screw of the OLP in any way.

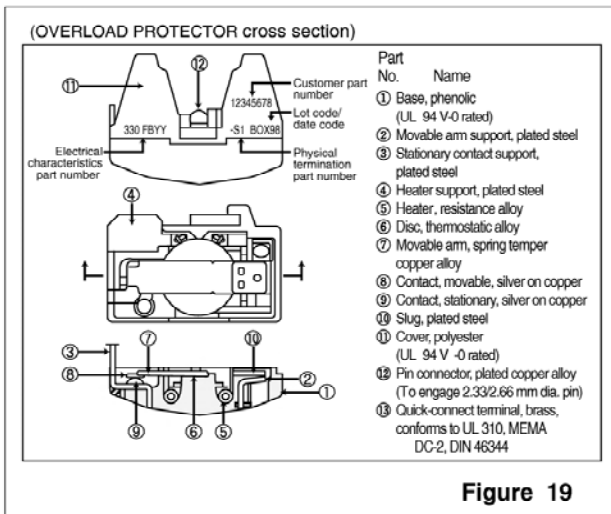
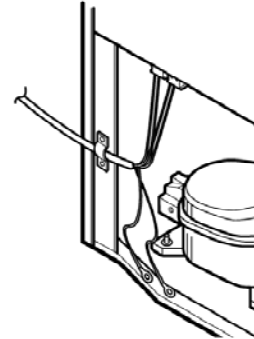
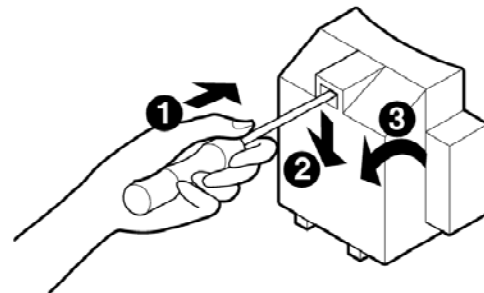

Figure 19

4-4 TO REMOVE THE COVER PTC



- (1) Remove the Cover Back M/C.
- (2) Disconnect two housing upper side of comp connected in.
- (3) Loosen two screws on comp base.



- (4) Use a L-shaped flap tool to pry off the cover.
- (5) Assembly in reverse order of disassembly.

5. CIRCUIT DIAGRAM

SEARS BEST MODEL

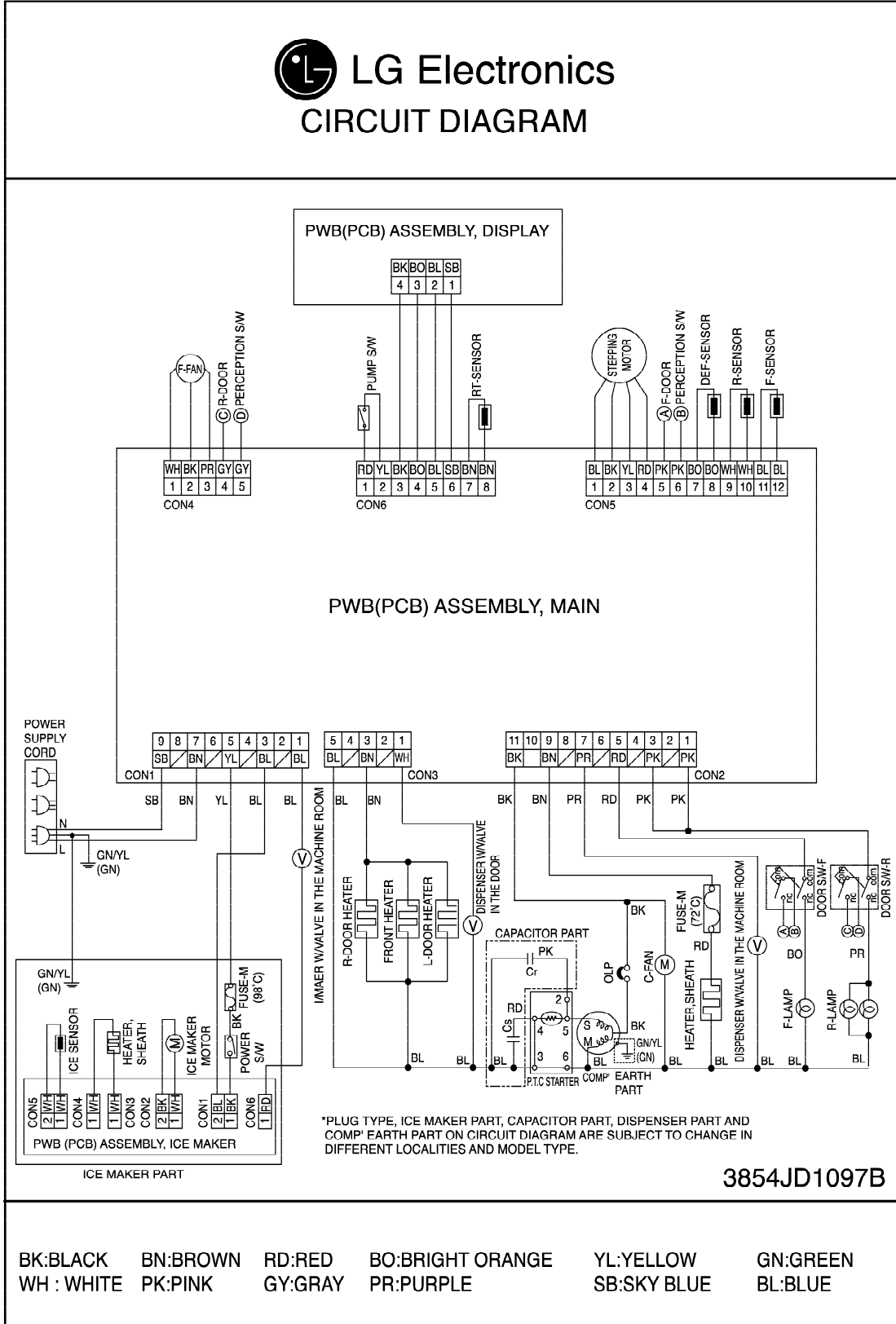

6. TROUBLESHOOTING

6-1 COMPRESSOR AND ELECTRIC COMPONENTS

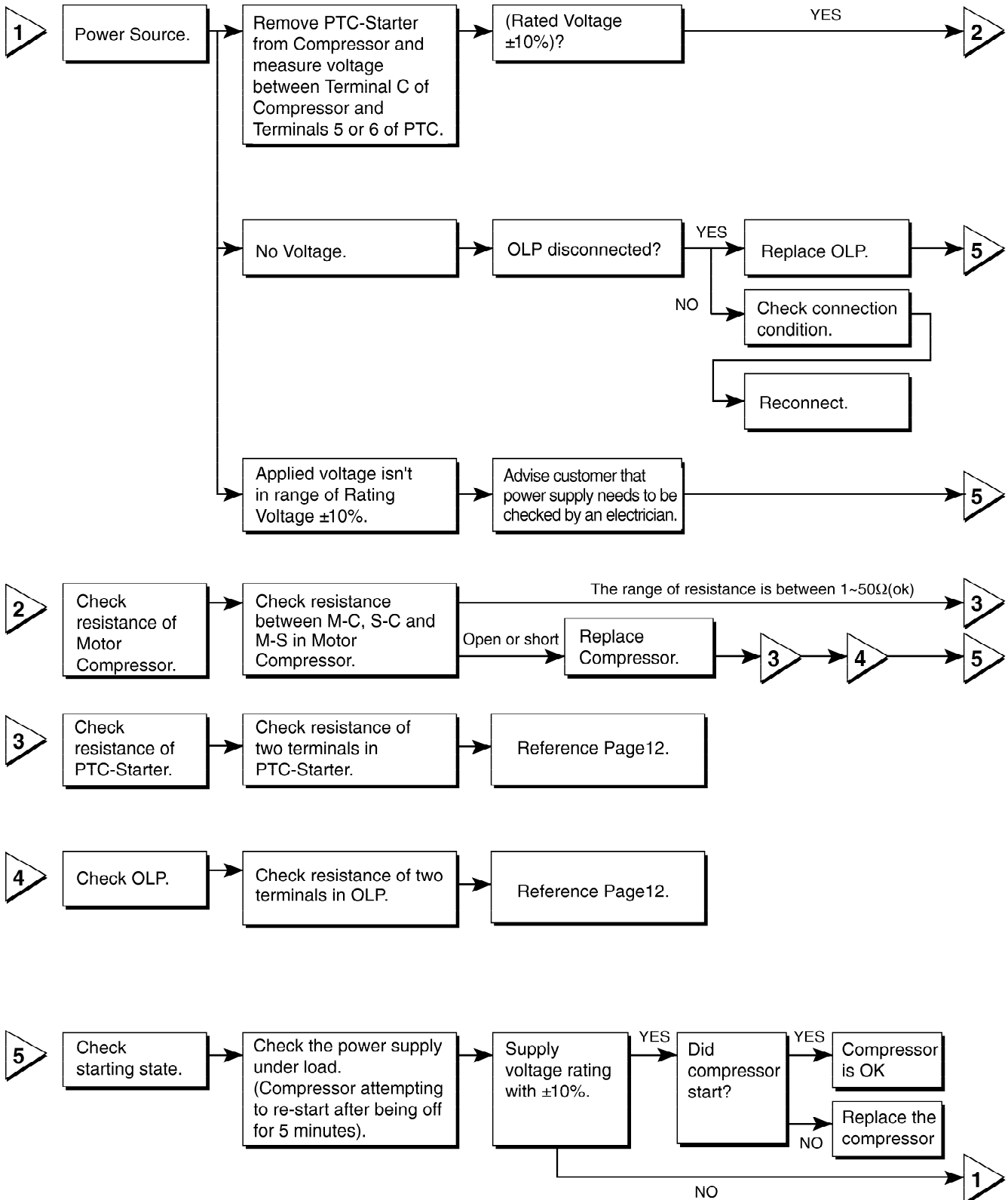

6-2 PTC AND OLP

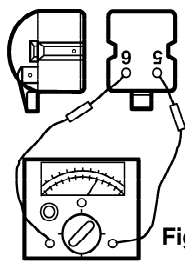
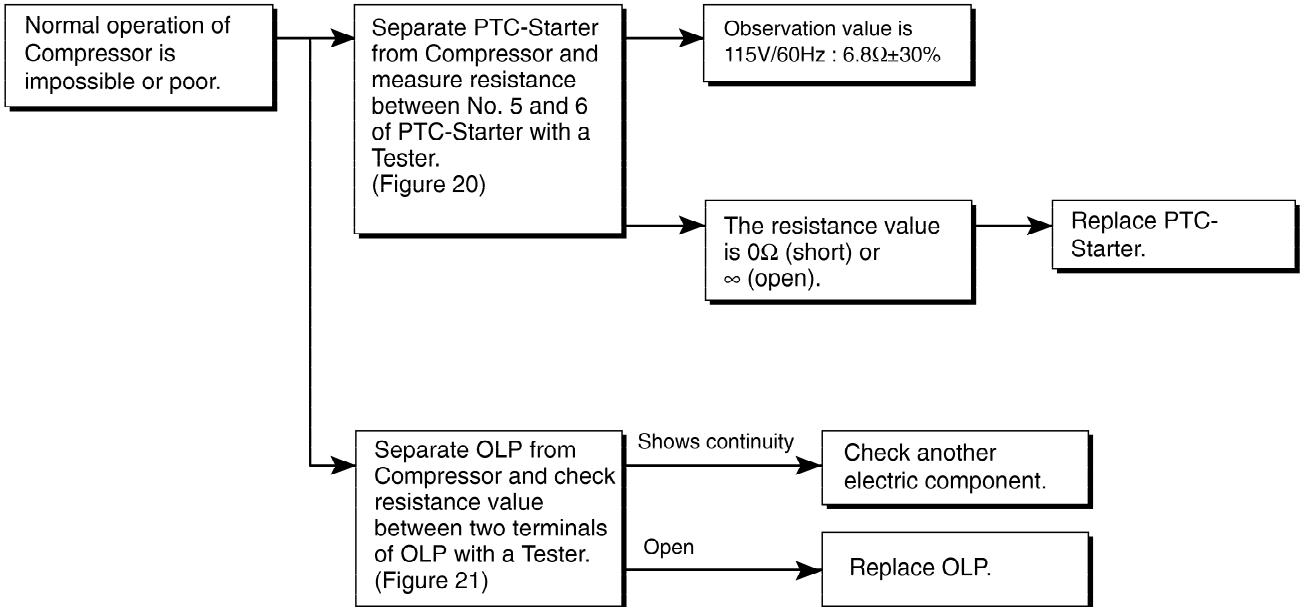

Figure 20

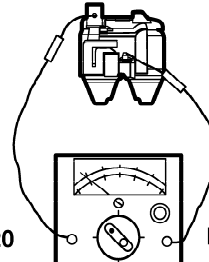
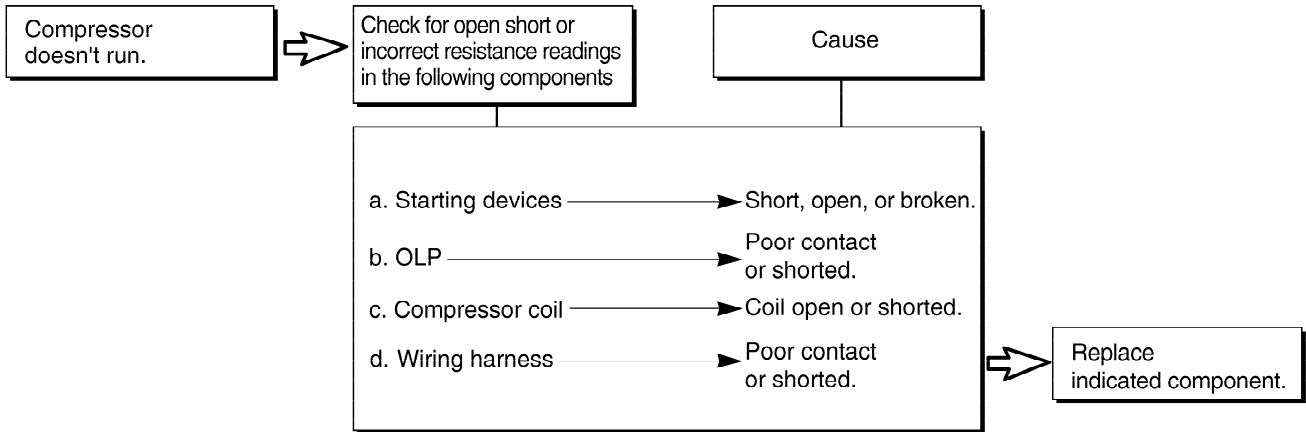

Figure 21

6-3 OTHER ELECTRICAL COMPONENTS

▼ Not cooling at all



▼ Poor cooling performance

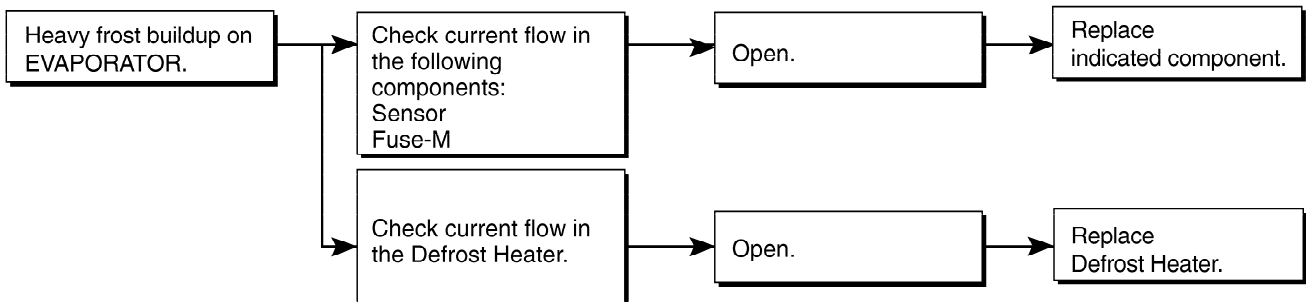
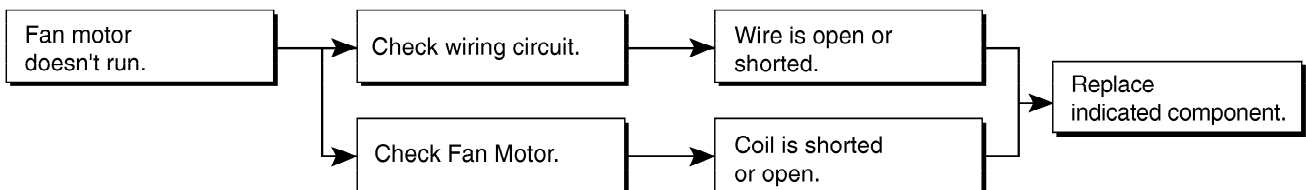
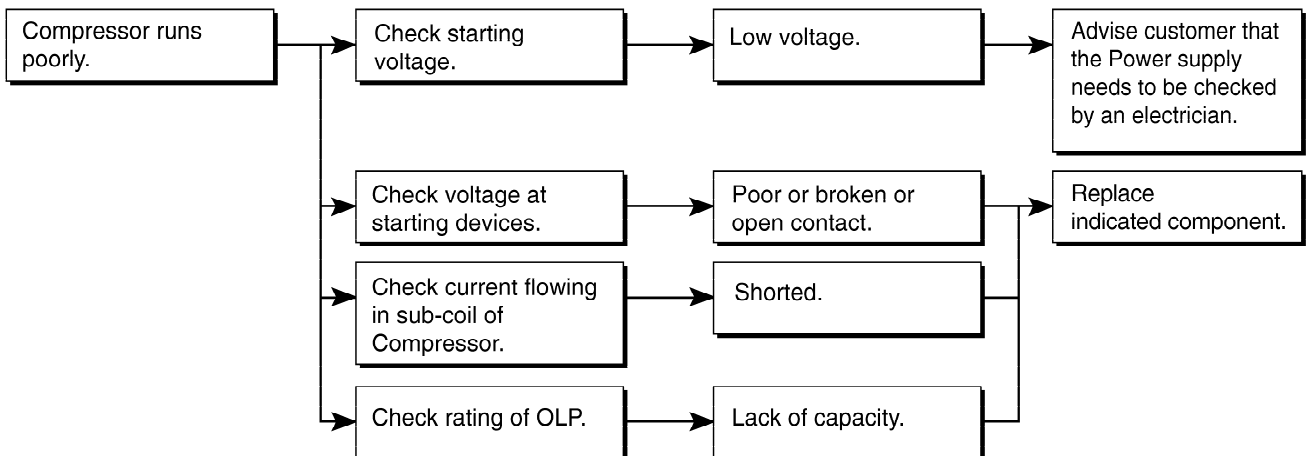

6-4 SERVICE DIAGNOSIS CHART

COMPLAINT	POINTS TO BE CHECKED	REMEDY
No Cooling.	<ul style="list-style-type: none"> • Is the power cord unplugged from the outlet? • Check if the power switch is set to OFF. • Check if the fuse of the power switch is shorted. • Measure the voltage of the power outlet. 	<ul style="list-style-type: none"> • Plug into the outlet. • Set the switch to ON. • Replace the fuse. • If the voltage is low, correct the wiring.
Cools poorly.	<ul style="list-style-type: none"> • Check if the unit is placed too close to the wall. • Check if the unit is placed too close to the stove, gas cooker, or in direct sunlight. • Is the ambient temperature too high or the room door closed? • Check if food put in the refrigerator is hot. • Did you open the door of the unit too often or check if the door is sealed properly? • Check if the Control is set to Warm position. 	<ul style="list-style-type: none"> • Place the unit about 4 inches (10 cm) from the wall. • Place the unit away from these heat sources. • Lower the ambient temperature. • Put in foods after they have cooled down. • Don't open the door too often and close it firmly. • Set the control to Recommended position.
Foods in the Refrigerator are frozen.	<ul style="list-style-type: none"> • Is food placed in the cooling air outlet? • Check if the control is set to colder position. • Is the ambient temperature below 41°F(5°C)? 	<ul style="list-style-type: none"> • Place foods in the high-temperature section. (front part) • Set the control to Recommended position. • Set the control to Warm position.
Condensation or ice forms inside the unit.	<ul style="list-style-type: none"> • Is liquid food sealed? • Check if food put in the refrigerator is hot. • Did you open the door of the unit too often or check if the door is sealed properly? 	<ul style="list-style-type: none"> • Seal liquid foods with wrap. • Put in foods after they have cooled down. • Don't open the door too often and close it firmly.
Condensation forms in the Exterior Case.	<ul style="list-style-type: none"> • Check if the ambient temperature and humidity of the surrounding air are high. • Is there a gap in the door gasket? 	<ul style="list-style-type: none"> • Wipe moisture with a dry cloth. It will disappear in low temperature and humidity. • Fill up the gap.
There is abnormal noise.	<ul style="list-style-type: none"> • Is the unit positioned in a firm and even place? • Are any unnecessary objects placed in the back side of the unit? • Check if the Drip Tray is not firmly fixed. • Check if the cover of the compressor enclosure in the lower front side is taken out. 	<ul style="list-style-type: none"> • Adjust the Leveling Screw, and position the refrigerator in a firm place. • Remove the objects. • Fix the Drip Tray firmly in the original position. • Place the cover in its original position.
Door does not close well.	<ul style="list-style-type: none"> • Check if the door gasket is dirty with an item like juice. • Is the refrigerator level? • Is there too much food in the refrigerator? 	<ul style="list-style-type: none"> • Clean the door gasket. • Position in the firm place and level the Leveling Screw. • Make sure food stored in shelves does not prevent the door from closing.
Ice and foods smell unpleasant.	<ul style="list-style-type: none"> • Check if the inside of the unit is dirty. • Are foods with a strong odor unwrapped? • The unit smells of plastic. 	<ul style="list-style-type: none"> • Clean the inside of the unit. • Wrap foods that have a strong odor. • New products smell of plastic, but this will go away after 1-2 weeks.

● Other possible problems:

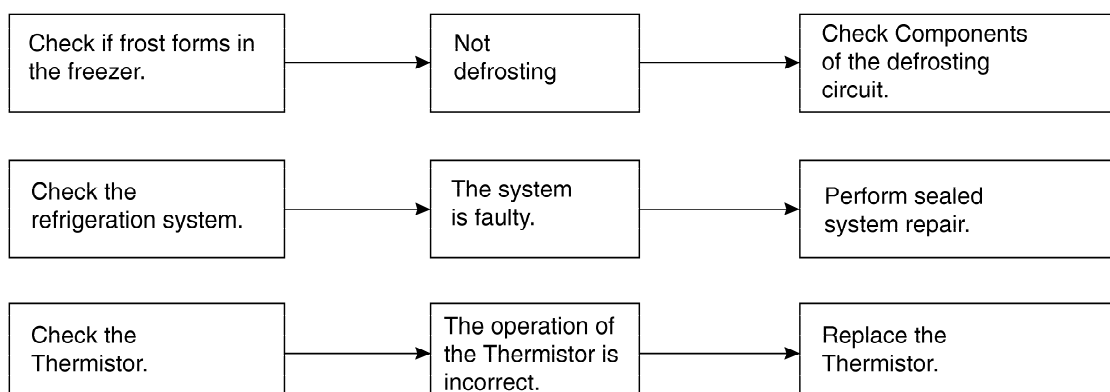

6-5 REFRIGERATION CYCLE

▼ Troubleshooting Chart

CAUSE		STATE OF THE UNIT	STATE OF THE EVAPORATOR	TEMPERATURE OF THE COMPRESSOR	REMARKS
LEAKAGE	PARTIAL LEAKAGE	Freezer compartment and Refrigerator don't cool normally.	Low flowing sound of Refrigerant is heard and frost forms in inlet only.	A little higher than ambient temperature.	<ul style="list-style-type: none"> Refrigerant level is low due to a leak. Normal cooling is possible by restoring the normal amount of refrigerant and repairing the leak.
	COMPLETE LEAKAGE	Freezer compartment and Refrigerator don't cool normally.	Flowing sound of refrigerant is not heard and frost isn't formed.	Equal to ambient temperature.	<ul style="list-style-type: none"> No discharging of Refrigerant. Normal cooling is possible by restoring the normal amount of refrigerant and repairing the leak.
CLOGGED BY DUST	PARTIAL CLOG	Freezer compartment and Refrigerator don't cool normally.	Flowing sound of refrigerant is heard and frost forms in inlet only.	A little higher than ambient temperature.	<ul style="list-style-type: none"> Normal discharging of the refrigerant. The capillary tube is faulty.
	WHOLE CLOG	Freezer compartment and Refrigerator don't cool.	Flowing sound of refrigerant is not heard and frost isn't formed.	Equal to ambient temperature.	<ul style="list-style-type: none"> Normal discharging of the Refrigerant.
MOISTURE CLOG		Cooling operation stops periodically.	Flowing sound of refrigerant is not heard and frost melts.	Lower than ambient temperature.	<ul style="list-style-type: none"> Cooling operation restarts when heating the inlet of the capillary tube.
DEFECTIVE COMPRESSION	COMP-RESSION	Freezer and Refrigerator don't cool.	Low flowing sound of refrigerant is heard and frost forms in inlet only.	A little higher ambient temperature.	<ul style="list-style-type: none"> Low pressure at high side of compressor due to low refrigerant level.
	NO COMP-RESSION	No compressing operation.	Flowing sound of refrigerant is not heard and there is no frost.	Equal to ambient temperature.	<ul style="list-style-type: none"> No pressure in the high pressure part of the compressor.

6-5-1 SEALED SYSTEM DIAGNOSIS

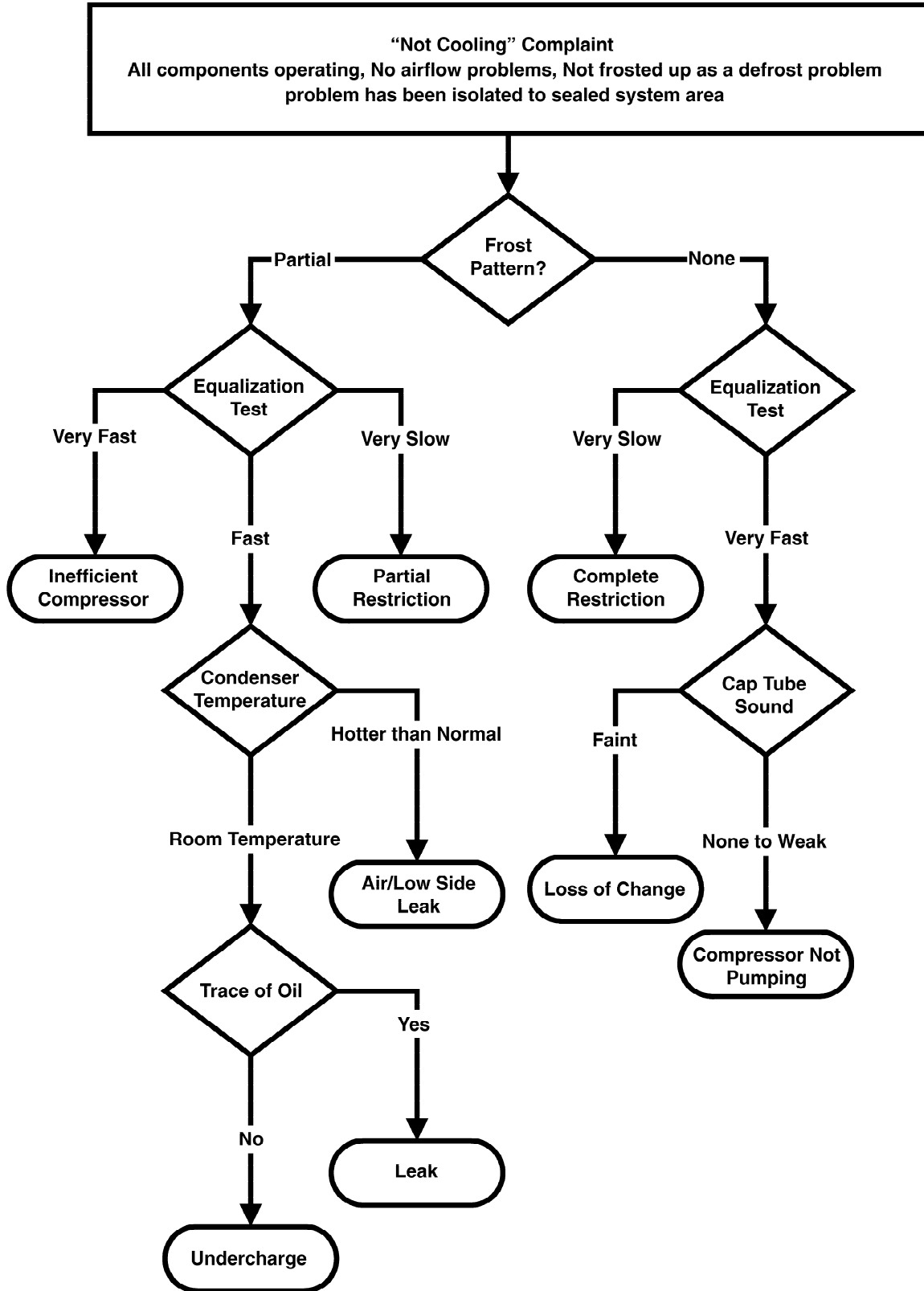

(The equalization test is trying to restart a compressor using a start kit after it has been operating.)

7. OPERATION PRINCIPLE AND REPAIR METHOD OF ICEMAKER

7-1 OPERATION PRINCIPLE

7-1-1 Operation Principle of IceMaker

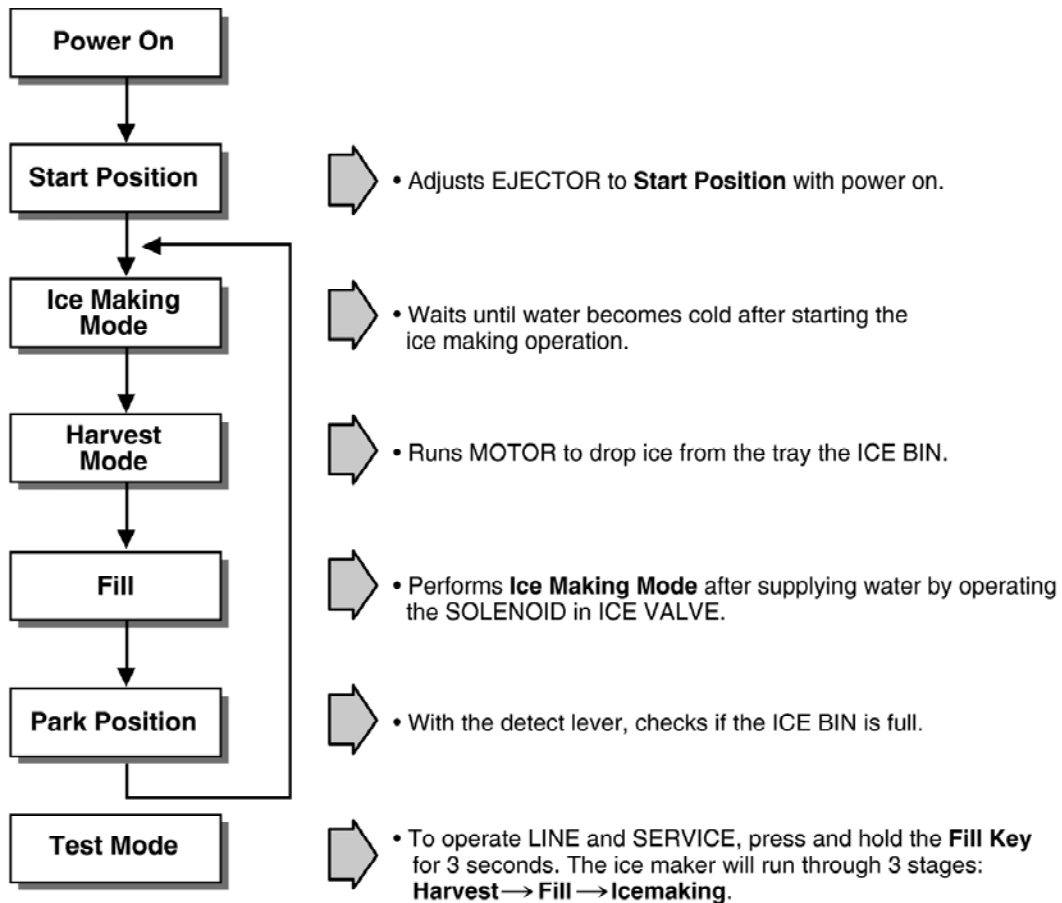

1. Turning the Icemaker stop switch off (O) stops the ice making function.
2. Setting the Icemaker switch to OFF and then turning it back on will reset the icemaker control.

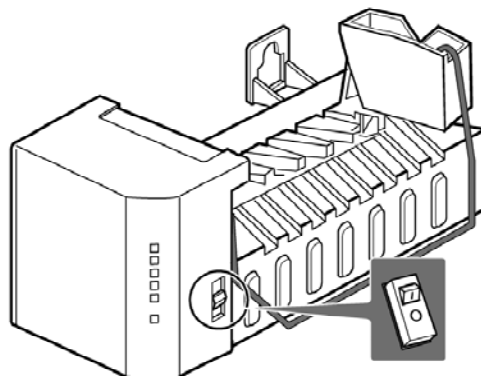

7-2 CONTROL METHOD ACCORDING TO FUNCTIONS

7-2-1 Start Position

1. After POWER OFF or Power Outage, check the EJECTOR's position with MICOM initialization to restart.
2. How to check if it is in place:
 - Check **HIGH/LOW** signals from HALL SENSOR in MICOM PIN.
3. Control Method to check if it is in place:
 - (1) EJECTOR is in place,
 - It is an initialized control, so the mode can be changed to ice making control.
 - (2) EJECTOR isn't in place:
 - A. If EJECTOR is back in place within 2 minutes with the motor on, it is being initialized. If not, go to Step B.
 - B. If EJECTOR is back in place within 18 minutes with the heater on (to control Heater on its OFF condition), it is being initialized. If not, it is not functioning. Repeat Step B with Heater and Motor off.

7-2-2 Ice Making Mode

1. The Ice Making Mode starts once the ejector is in the park position and the ice maker mold is filled with water.
2. The Ice Making Mode is terminated when the ice maker sensor reaches 19°F(-7°C). This may take between 1 and 4 hours.

7-2-3 Harvest Mode

1. The Harvest mode is initiated when the temperature is satisfied with the shut-off arm in the down position.
2. Once the Harvest mode is initiated, the heater is operated for 30 seconds.
3. After 30 seconds, the ejector blades are operated.
4. Once the ejector blades have reached the park position water fill will be initiated.



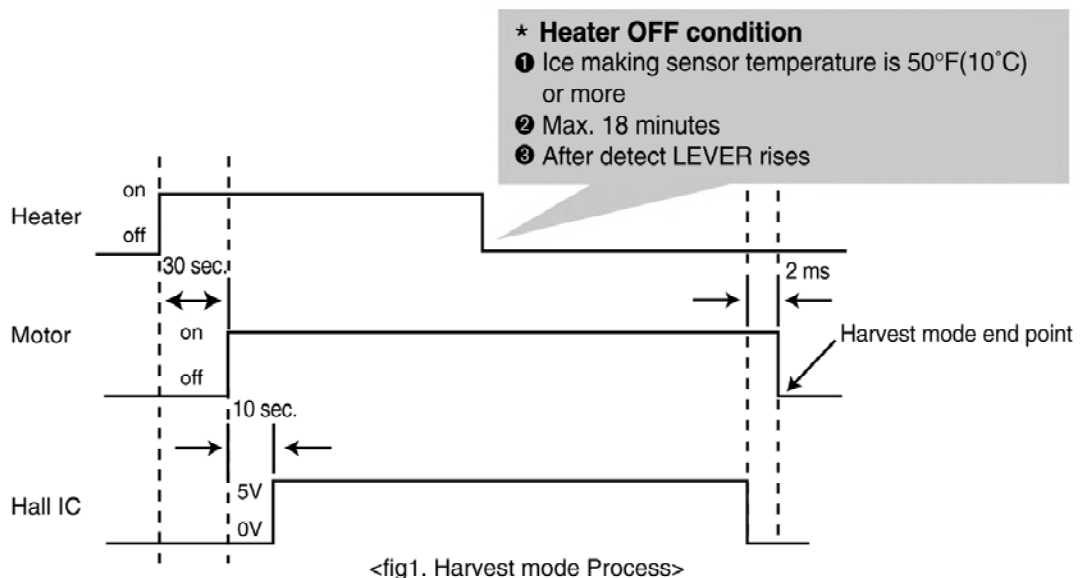

NOTE : If the movement is detected from the shut-off arm (detect lever), a harvest mode will be attempted every 2 hours.



7-2-4 Fill / Park Position

- Once a normal harvest mode has been completed, the water solenoid will be activated.
- The amount of water is adjusted by pressing the water supply control S/W. This changes the time allowed for fill as illustrated in the chart.

<Water supply amount TABLE>

STAGE	TIME TO SUPPLY	INDICATIONS	REMARKS
1	6 sec.		The water amount will vary depending on the water control Switch setting, as well as the water pressure of the connected water line.
2	6.5 sec.		
3	7 sec.		
4	7.5 sec.		
5	8 sec.		



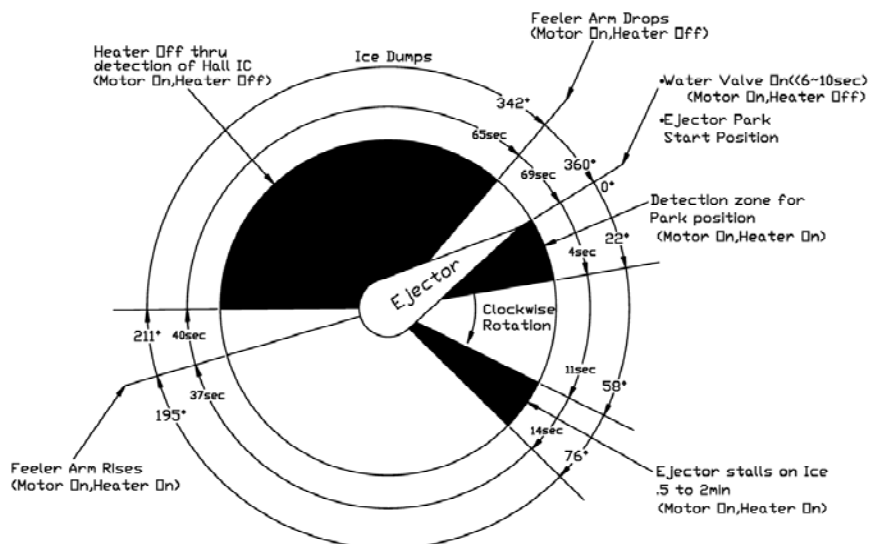

NOTE : Below is an example used by another vendor as an explanation of what is taking place.



7-2-5 Function TEST



1. This is a compulsory operation for TEST, SVC, cleaning, etc. It is operated by pressing the water supply control KEY for 3 seconds.
2. It operates in the Ice Making mode, but not in the Ice-Removing mode or water supply process. (If there is an ERROR, it can only be checked in the TEST mode.)
3. If the water supply control KEY is pressed for 3 seconds in the Ice-Making mode (no matter what condition the Ice-Making tray is in) the Ice-Removing operation starts immediately. Water is not yet frozen, so water is poured instead of ice. If the control doesn't operate normally in the TEST mode, check and repair as needed.
4. After water is supplied, the normal CYCLE is followed: **ice making** → **Harvest** → **Fill** → **Park Position**.
5. When Stage 5 is completed in the TEST mode, minimize MICOM in 5 seconds, the time needed to supply water resets to the previous status in the TEST mode.

<Diagnosis TABLE>

STAGE	ITEMS	INDICATOR	REMARKS
1	HEATER		Five seconds after heater starts, heater will go off if temperature recorded by sensor is 50°F(10°C) or lever is in up position.
2	MOTOR		Five seconds after heater starts, you can confirm that motor is moving.
3	HALL IC I (detection of position)		You can confirm Hall Ic detection of position.
4	VALVE		Two seconds after detection of initial position, you can confirm that valve is on.
5	HALL IC II (detection of full-filled Ice)		You can check whether hall is sensing Full ice condition. (If there is a full-filled error, the fifth LED is not on.)
6	Reset	Mark Previous Status on TEST MODE	Five seconds after fifth stage is completed, the icemaker reset at initial status.

7-3 DEFECT DIAGNOSIS FUNCTION

7-3-1 ERROR CODES shown on Ice Maker water supply control panel

NO	DIVISION	INDICATOR	CONTENTS	REMARKS
1	Normal	Mark time to supply	None	Display switch operates properly
2	Ice-Making Sensor malfunction		Open or short-circuited wire	Make sure that the wire on each sensor is connected.
3	Ice Maker Kit malfunction		When ejector blades don't reach park position over 18 minutes since Harvest Mode starts.	Check of HALL IC/MOTOR/HEATER/RELAY

ERROR indicators in table can be checked only in TEST mode.

8. DESCRIPTION OF FUNCTION & CIRCUIT OF MICOM

8-1 FUNCTION

8-1-1 Function

1. When the appliance is plugged in, it is set to "37" for Refrigerator and "0" for freezer.
You can adjust the Refrigerator and the Freezer control temperature by pressing the ADJUST button.
2. When the power is initially applied or restored after a power failure, it is automatically set to "37" & "0".

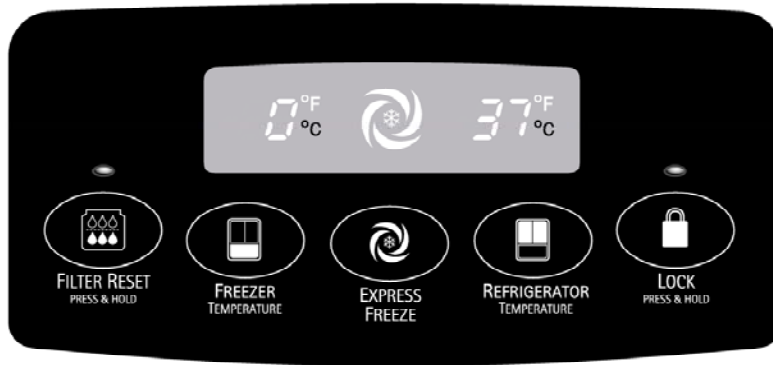

8-1-2 How to Change the Temperature Mode to °F / °C

1. The setting temperature mode can be changed to °F / °C by pressing and holding Freezer Temp. key of Freezer and Refrigerator Temp. key of Refrigerator over 3 seconds. at the same time.
2. The initial setting is °F. Whenever the mode is changed, the LED lights are changed.

8-1-3 Lock function (dispenser and display button lock)

1. In power application of refrigerator, the "LOCK" LED is turned off at the upper side of lock graphic of display with the lock release status.
2. If desiring to lock the display the dispenser and control panel push on the LOCK button more than 3 seconds. LOCK text is turned on at the upper side of lock graphic of display with lock status.
3. The buzzer sound and control panel and dispenser function is not performed even if pressing display button other than lock key in the lock status.
4. If desiring to release the lock status and pressing the lock button more than 3 seconds. "LOCK" LED is turned off at the upper side of lock graphic of display with the lock release status.

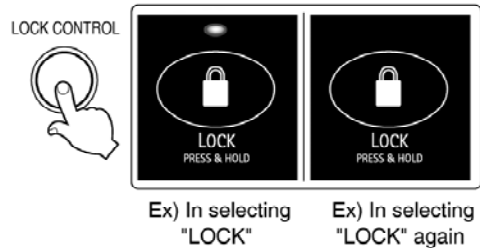

8-1-4 Filter condition display function

1. There is a replacement indicator light for the water filter cartridge on the dispenser.
2. Water filter needs replacement once six months or about 28,000 seconds of using water filter.
3. Water filter light turns on to tell you need to replace the filter soon.
4. After replace the filter, press and hold the lock button more than 3 seconds.
Then water filter light turns off with reset status.

Classification	In initial Power On / Filter RESET	Replace indicator light on
Filter Status Display		

8-1-5 Express freezing selection

Please select this function for prompt freezer.

- Function is repeated following below whenever pressing Express FRZ button.
- Expressing freezer function automatically turns off if a fixed time passes.

EXPRESS FREEZER



8-1-6 CONTROL OF FREEZER FAN MOTOR

1. Freezer fan motor has high and standard speeds.
2. High speed is used at power-up, for express freezing, and when refrigerator is overloaded.
Standard speeds is used for general purposes.
3. To improve cooling speed, the RPM of the freezer fan motor change from normal speed to high.
4. High speed (2700RPM) : Initial power on or load corresponding operation, express freezing.
Normal speed (2400RPM) : General working conditions.
5. Fan motor stops when refrigerator or freezer door opens.

8-1-7 EXPRESS FREEZING

1. The purpose of this function is to intensify the cooling speed of freezer and to increase the amount of ice.
2. When EXPRESS FREEZE is selected, LED will remain ON for Express Freeze Cycle.
3. If power is lost to the refrigerator, EXPRESS FREEZING function will be canceled.
4. To activate this function, to press the Express Freezing key and the LED will turn ON. This function will remain activated for 24 hrs. The first three hours the compressor and Freezer Fan will be ON. The next 21 hours the freezer will be controlled at the lowest temperature. After 24 hours or if the Express Freezing key is pressed again, the freezer will return to its previous temperature.
5. For the first three hours notice the following cases:
 - (1) Compressor and freezer fan (HIGH RPM) continuously operate for three hours.
 - (2) If defrost starts during EXPRESS FREEZING, EXPRESS FREEZING operates for the rest of time after defrost is completed, when EXPRESS FREEZING operation time is less than 90 minutes.
If EXPRESS FREEZING operates for more than 90 minutes, the EXPRESS FREEZING will operate for two hours after defrost is completed.
 - (3) If EXPRESS FREEZING is pressed during defrost, EXPRESS FREEZING LED is on but this function will start seven minutes after defrost is completed and it shall operate for three hours.
 - (4) If EXPRESS FREEZING is selected within seven minutes after compressor has stopped, the compressor (compressor delays seven minutes) shall start after the balance of the delay time.
 - (5) The fan motor in the freezer compartment runs at high speed during EXPRESS FREEZING .
6. For the rest of the 21 hours, the freezer will be controlled at the lowest temperature.

8-1-8 REFRIGERATOR LAMP AUTO OFF

1. To avoid heat damage caused by the lamp, it is turned off automatically when the refrigerator door is open for more than 7 minutes.

8-1-9 Alarm for Open Door

1. This feature sounds a buzzer when the freezer or refrigerator door is not closed within 1 minute after it is opened.
2. One minute after the door is opened, the buzzer sounds three times each for 1/2 seconds. These tones repeat every 30 seconds.
3. The alarm is cancelled when the freezer or the refrigerator is closed while the buzzer sounds.

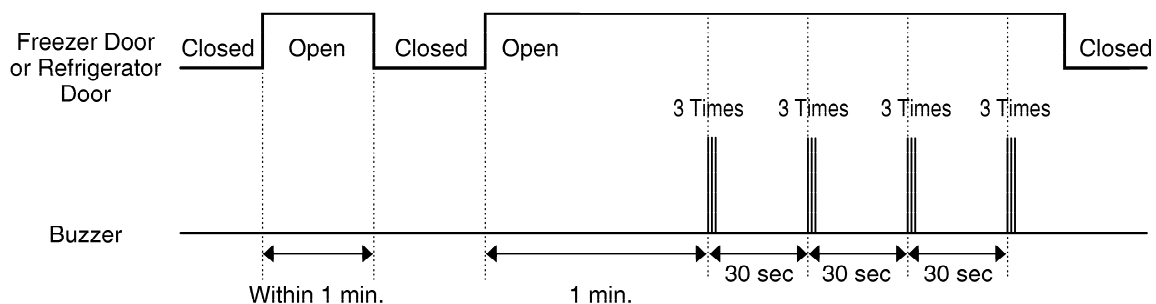

8-1-10 Buzzer Sound

When the button on the front Display is pushed, a Ding~ Dong~ sound is produced.

8-1-11 Defrost cycle

1. A defrost cycle will be initiated after 4 hours of accumulated compressor run time after the initial power up or a power failure.
2. After the initial defrost, the defrost cycle is initiated after 7 hours of accumulated compressor run time.
3. The defrost cycle will be terminated once the defrost sensor reaches 50°F(10°C).

8-1-12 Filter Replacement Indication

1. In 6 months after the UNIT (refrigerator) is power on, or after 28,000 seconds of dispenser use, the water filter Indicator LED will be ON.
2. When the water filter indicator LED is illuminated, you should change the water filter. After this, you must press the water filter button for three seconds and you will hear a ding-dong sound.
The LED will be OFF. This operation will indicate that the UNIT is reset to its initial conditions, so this process is restarted.

8-1-13 Automatic Diagnosis Function

1. Automatic diagnosis makes servicing the refrigerator easy.
2. When an error occurs, the buttons will not operate; but the tones, such as ding, will sound.
3. When the error CODE removes the sign, it returns to normal operation (RESET).
4. The error CODE shows on the Refrigerator and Freezer Display.

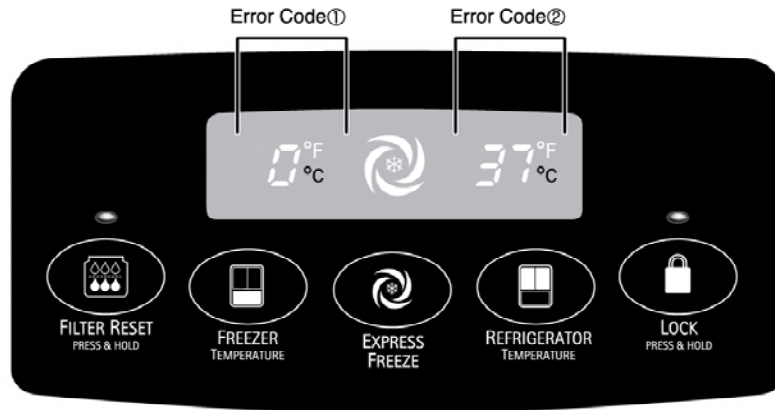

ERROR CODE on display panel

NO	ITEM	ERROR CODE		POSSIBLE PROBLEMS	REMARKS
		①	②		
1	Freezer sensor	Er	FS	Cut or short circuit wire	Inspect Connecting wires on each sensor
2	Refrigerator sensor	Er	rS	Cut or short circuit wire	
3	Defrost sensor	Er	dS	Cut or short circuit wire	
4	Room Temperature sensor	Wher Display check mode Er rt		Cut or short circuit wire	
5	Defrost mode	Er	dH	When defrost sensor doesn't reach 46°F(8°C) within 1 hours after starting defrost.	Snapping of defrost heater or Temperature fuse, pull-out of connector (indicated minimum 1 hours after failure occurs)
6	BLDC Fan Motor at Freezing Compartment.	Er	FF	If there is no fan motor signal for more than 65sec in operation fan motor	Poor motor, hooking to wires of fan, contact of structures to fan, snapping or short circuit of Lead wires

* LED check function: If simultaneously pressing express freezer button and freezing temperature adjustment button for a second, display LED graphics on. If releasing the button, the LED graphic displays the previous status.

8-1-14 TEST Mode

1. The Test mode allows checking the PCB and the function of the components as well as finding out the defective part in case of an error.
2. The test mode is operated by pressing two buttons at Display panel.
3. While in the test mode, the function control button is not recognized, but the recognition tone (beep~) sounds.
4. After exiting the test mode, be sure to reset by unplugging and then plugging in the appliance.
5. If an error, such as a sensor problem, is detected while in the test mode, the test mode is cleared and the error code is displayed.
6. While an error code is displayed, the test mode will not be activated.

MODE	MANIPULATION	CONTENTS	REMARKS
TEST1	Push Express Freezing Key and LOCK KEY at the same time over 3 seconds OR Push TEST S/W(in the main Board) once.	1) Continuous operation of the COMPRESSOR and the Freezer fan 2) Stepping DAMPER OPEN 3) Defrosting HEATER OFF 4) DISPLAY LED all ON	
TEST2	Push Express Freezing Key and LOCK KEY at the same time over 3 seconds in TEST MODE 1 OR Push TEST S/W once in TEST MODE 1	1) Continuous operation of the COMPRESSOR and the Freezer fan 2) Stepping DAMPER CLOSE 3) Defrosting HEATER OFF 4) DISPLAY LED shows no. 2	
TEST3	Push Express Freezing Key and LOCK KEY at the same time over 3 seconds in TEST MODE 2 OR Push TEST S/W once in TEST MODE 2	1) COMPRESSOR and the Freezer fan OFF 2) Stepping DAMPER CLOSE 3) Defrosting HEATER ON 4) DISPLAY LED shows no. 3	Reset if the Temperature of the Defrosting Sensor is 46°F(8°C) or more.
Reset	Push Express Freezing Key and LOCK KEY at the same time over 3 seconds in TEST MODE 3 OR Push TEST S/W once in TEST MODE 3	Reset to the previously setting Before TEST MODE.	The compressor will Start after a 7-minute Delay.

*** Freezer Fan RPM Variable Check:**

In case the freezer fan is in operation when the express freezer button and freezing temp. button. Control are pressed for more than one second at the same time freezer fan RPM changes. (for example if high speed, to normal speed or if normal speed, to high speed for 30 seconds)
After 30 seconds, it turns to its original RPM.

*** Demonstration MODE:**

1. When the Express Freeze button and the Refrigerator Temperature Control button are pushed at the same time and hold for 5 seconds or longer, it converts to Demonstration Mode.
2. The Display shows the Demo graphic.
3. In this status, all Loads are off (Compressor / Fan / Damper / Heater)
(Even is Demonstration Mode, the refrigerator Lamp automatic off function works normally and can be demonstrated)
4. Exit Demonstration mode and reset Display by pressing the Express Freeze button and the Refrigerator Temperature Control button for 5 seconds or longer.

8-2 PCB FUNCTION

8-2-1 Power Circuit

1. Power is supplied to the control board at pin7 and 9 od connector #1.

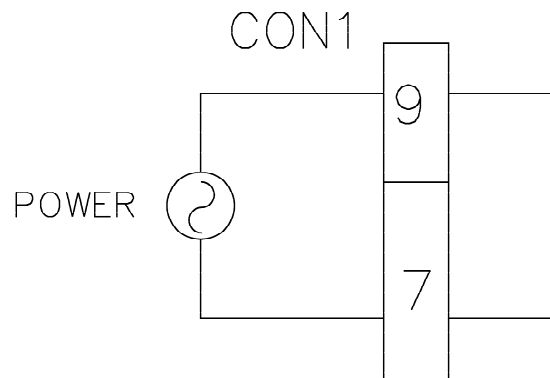

8-2-2 Load / Buzzer Drive & Open Door Detection Circuit

1. Load Drive Condition Check

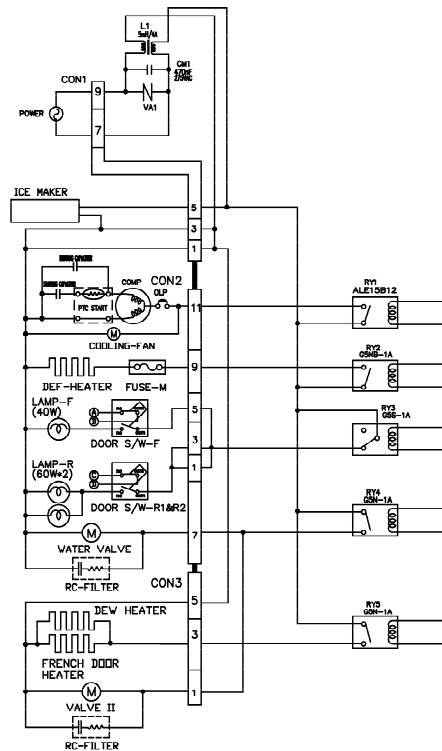

To measure outputs of the control board, check voltages between the pins for the following components:

Circuit	Pin Number	Pin Number	Output Voltage
Compressor	Con2 pin11	Con1 pin1	115 VAC
Condenser fan	Con2 pin11	Con1 pin1	115 VAC
Defrost heater	Con2 pin9	Con1 pin1	115 VAC
F,R-lamp	Con2 pin,3.5	Con1 pin1	115 VAC
Water valve	Con2 pin7	Con1 pin1	115 VAC
Dew heater	Con2 pin3	Con1 pin1	115 VAC
Water valve	Con2 pin1	Con1 pin1	115 VAC

NOTE: When the door of the freezer/refrigerator is left open for 7 minutes or longer, the lamp of the freezer/refrigerator turns.

2. Fan motor driving circuit (freezing compartment fan)

	Pin1 & 2 of con4
MOTOR OFF	2V or less
MOTOR ON	13V~15V

3. Open Door Detection Circuit Check

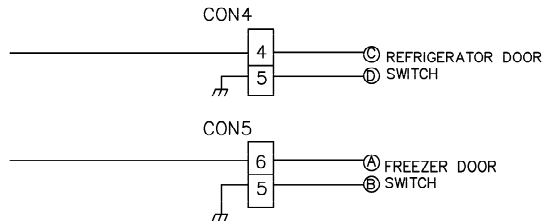

8-2-3 Temperature Sensor Circuit

Measurement Location Freezer/ Refrigerator Door	Pin 4 & 5 of con4 Ref.Door Pin 5 & 6 of con5 Fre.Door
Closed	0 V
Open	5 V

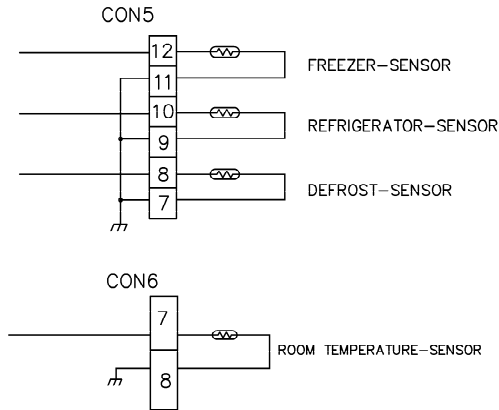

TEMPERATURE	RESISTANCE OF FREEZER SENSOR	RESISTANCE OF REFRIGERATOR & DEFROST SENSOR & ROOM SENSOR
- 20 °C (-4 °F)	22.3 KΩ	77 KΩ
- 15 °C (5 °F)	16.9 KΩ	60 KΩ
- 10 °C (14 °F)	13.0 KΩ	47.3 KΩ
- 5 °C (23 °F)	10.1 KΩ	38.4 KΩ
0 °C (32 °F)	7.8 KΩ	30 KΩ
+ 5 °C (41 °F)	6.2 KΩ	24.1 KΩ
+ 10 °C (50 °F)	4.9 KΩ	19.5 KΩ
+ 15 °C (59 °F)	3.9 KΩ	15.9 KΩ
+ 20 °C (68 °F)	3.1 KΩ	13 KΩ
+ 25 °C (77 °F)	2.5 KΩ	11 KΩ
+ 30 °C (86 °F)	2.0 KΩ	8.9 KΩ
+ 40 °C (104 °F)	1.4 KΩ	6.2 KΩ
+ 50 °C (122 °F)	0.8 KΩ	4.3 KΩ

- The resistance of the SENSOR has a ±5% common difference.
- Measure the resistance of the SENSOR after leaving it for over 3 minutes in the measuring temperature. This delay is necessary due to sensor response speed.

8-2-4 Refrigeration Compartment Stepping Motor Damper Circuit

A reversible DC motor is used to open and close the damper.

To open the damper, push test button once.

To close the damper, push test button twice.

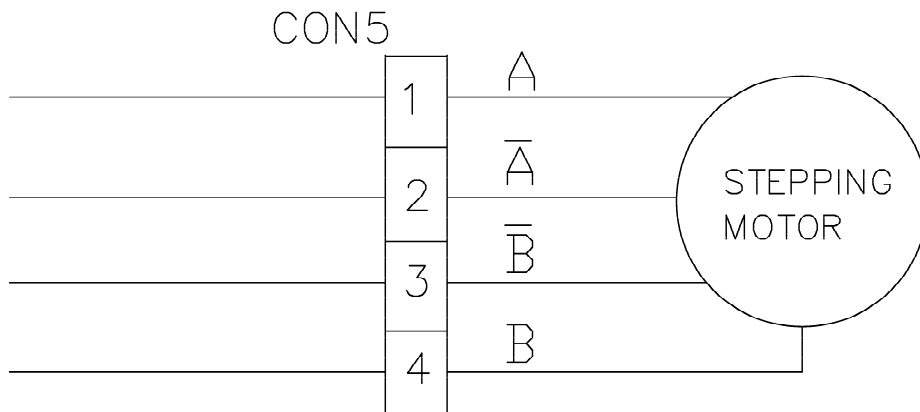

8-3 TROUBLESHOOTING

PROBLEM	INDICATED BY	CHECK	CHECKING METHOD	CAUSE	SOLUTION						
POWER SOURCE is poor.	1. The whole DISPLAY LED/SEVEN SEGMENT DISPLAY is off. 2. DISPLAY LED/SEVEN SEGMENT DISPLAY operates abnormally	1. FREEZER/ REFRIGERATOR.	Check if FREEZER/REFRIGERATOR DOOR IS OPEN and check display.	POWER SOURCE is poor.	Use boosting TRANS.						
		2. If LAMP is dim.	Check visually.	Applied voltage error.	Reconnect CONNECTOR.						
		3. The connection of the MAIN PWB CONNECTOR.	Check connection of CONNECTOR.	CONNECTOR connection is poor.	Replace TRANS.						
				TRANS FUSE is open.	Replace COMPRESSOR.						
COOLING is poor.	NO COOLING.	1. If the COMPRESSOR operate.	USE TEST MODE1 (forced COOLING). If less than 7 minutes pass after compressor shuts off, don't press the KEY and wait.	COMPRESSOR locked or blocked.	Replace OLP, PTC.						
				OLP, PTC is poor. COMPRESSOR RELAY is poor.	Replace MAIN PWB.						
				THE CONNECTING WIRE is poor.	Check the connection of the black wire of the MAIN PWB CONNECTOR (CON2).						
		2. If refrigerant is leaking.		Measure the amount of frost sticking on EVAPORATOR and the surface temperature of the condenser pipe.	Refrigerant leakage.	Replace the leaking part and replace any lost refrigerant.					
							FREEZER TEMPERATURE is incorrect	1. If FAN MOTOR operates.	USE TEST MODE1 (forced COOLING).	FAN MOTOR is poor.	Replace the FAN MOTOR.
										CONNECTING WIRE is poor.	Certify the MOTOR and the connection of the black wire of the MAIN PWB CONNECTOR (CON2).
	FREEZER TEMPERATURE is incorrect	2. If DEFROSTING is normal.	Check the amount of frost sticking on the EVAPORATOR .	DEFROSTING is poor.	See DEFROSTING is poor.						
						3. If SENSOR is normal.	of the Refrigerator SENSOR.	SENSOR RESISTANCE is poor.	Replace SENSOR.		
										4. Door Line contact.	Check the seal when the door is closed.

PROBLEM	INDICATED BY	CHECK	CHECKING METHOD	CAUSE	SOLUTION
COOLING is poor.	If REFRIGERATOR TEMPERATURE is too low.	1. If FREEZER TEMPERATURE is normal.	Check is FREEZER TEMPERATURE is too low.		Make sure the DOOR is attached.
		2. If amount of cool air from FAN MOTOR is sufficient.	Make sure that the amount and speed of cool air are sufficient by touching the check supplied on the REFRIGERATOR.	FAN MOTOR is poor.	Replace FAN MOTOR.
				Passage of cool air is blocked.	Remove impurities.
				EVA frozen.	See DEFROSTING is poor.
3. Door Line contact.	Check door seal when door is closed.	Door liner damaged.	Replace Door liner.		
DEFROSTING is poor.	NO DEFROSTING.	1. If HEATER emits heat.	USE TEST MODE3 (forced DEFROSTING).	HEATER disconnection.	Replace HEATER.
				TEMPERATURE FUSE disconnection.	Replace TEMPERATURE FUSE.
				Connection is poor.	Check EVAPORATOR connection and wire of MAIN PWB CONNECTOR.
				DEFROST-SENSOR is poor.	Replace DEFROST-SENSOR.
				HEATER RELAY is poor.	Replace RY3 of MAIN PWB.
		2. If DRAIN PIPE is blocked.	Check DRAIN PIPE.	DRAIN PIPE is blocked.	Remove ice and impurities.
					Check HEATER PLATE resistance.
		3. If ice remains after DEFROSTING.	Make sure that DEFROST SENSOR is connected.	Connection is poor.	Reassemble the DEFROST-SENSOR.
					Make sure that FREEZER /REFRIGERATOR DOOR is closed.



REPAIR PARTS LIST

MODELS No.

- 795.75542401
- 795.75549401
- 795.75544401
- 795.75543401
- 795.75546401
- 795.75552401
- 795.75559401
- 795.75554401
- 795.75553401
- 795.75556401

The model number of your refrigerator is found on the serial plate inside.

All repair parts listed are available for immediate purchase or special order when you visit your nearest Sears Service Center, or the Service Department at most Sears stores. To order parts by phone, call the toll free parts number listed to the left.

When requesting service or ordering parts, always provide the following information:

- Product Type • Part Number
- Model Number • Part Description

To call Toll Free For Parts:

1-800-366-PART
(1-800-366-7278)

For Service:

1-800-4-MY-HOME
(1-800-469-4663)

Last Revision: MARCH. 14. 2005

Sears, Roebuck and Co., Hoffman Estates, IL 60179 U.S.A.

Get it fixed, at your home or ours!

Your Home

For repair – **in your home** – of **all** major brand appliances, lawn and garden equipment, or heating and cooling systems, **no matter who made it, no matter who sold it!**

For the replacement parts, accessories and owner's manuals that you need to do-it-yourself.

For Sears professional installation of home appliances and items like garage door openers and water heaters.

1-800-4-MY-HOME® (1-800-469-4663)

Call anytime, day or night (U.S.A. and Canada)

www.sears.com www.sears.ca

Our Home

For repair of carry-in items like vacuums, lawn equipment, and electronics, call or go on-line for the location of your nearest

Sears Parts & Repair Center.

1-800-488-1222

Call anytime, day or night (U.S.A. only)

www.sears.com

To purchase a protection agreement (U.S.A.) or maintenance agreement (Canada) on a product serviced by Sears:

1-800-827-6655 (U.S.A.)

1-800-361-6665 (Canada)

Para pedir servicio de reparación a domicilio, y para ordenar piezas:

1-888-SU-HOGAR™
(1-888-764-6427)

Au Canada pour service en français:

1-800-LE-FOYER™
(1-888-533-6937)
www.sears.ca



® Registered Trademark / ™ Trademark / ® Service Mark of Sears, Roebuck and Co.

® Marca Registrada / ™ Marca de Fábrica / ® Marca de Servicio de Sears, Roebuck and Co.

™ Marque de commerce / ™ Marque déposée de Sears, Roebuck and Co.

© Sears, Roebuck and Co.

ICE MAKER PARTS

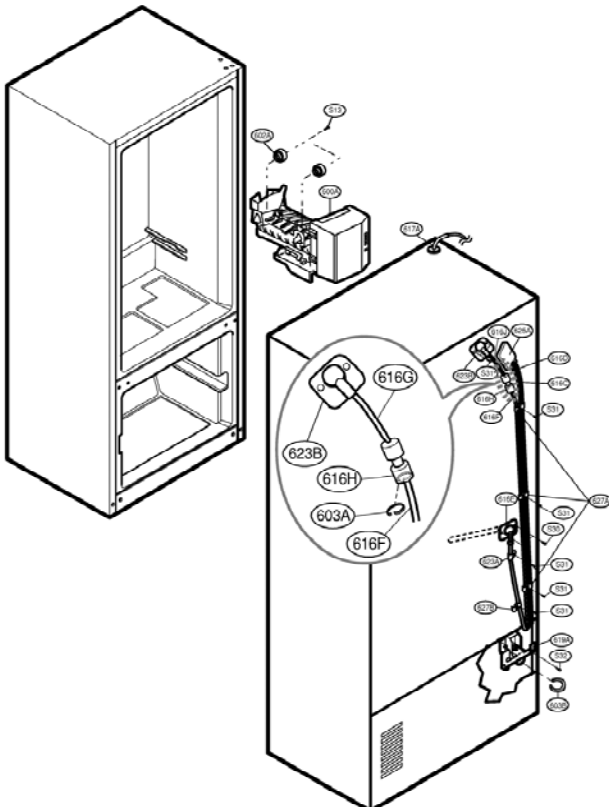

LOC No.	755**	Description
600A	5989JA0002F	ICE MAKER ASSEMBLY, KIT
602A	4930JA3090A	HOLDER, BRACKET
603A	4930JA3093B	HOLDER, BRACKET
603B	4930JA3091A	HOLDER, BRACKET
616C	5210JA3004U	TUBE, PE
616D	5210JA3005Q	TUBE, PE
616E	5211JA3003E	TUbe Assembly, Inject
616F	5210JA3004R	TUBE, PE
616G	5210JA3005S	TUBE, PE
616H	4932JA3002C	CONNECTOR (MECH), TUBE
617A	4970JA3004N	SPRING, W
619A	5221JB1004N	VALVE ASSEMBLY, WATER
623A	4770JA3001A	BAND (MECH)
623B	5006JJ2009A	CAP, COVER
625A	3550JA2184B	COVER, TUBE
627A	4930JJ3018A	HOLDER, PIPE
627B	4930JA3054A	HOLDER, PIPE
S13	1SZZJJ3005E	SCREW, DRAWING
S30	1SZZJA3009A	SCREW, DRAWING
S31	4J00415D	SCREW, DRAWING
S32	4000W4A003A	SCREW, DRAWING

CAUTION: Use the part number to order part, not the location number.

CASE PARTS

LOC No.	755*3	755*6	755*2	755*9	755*4	Description
103A	3650JA2113P	3650JA2113P	3650JA2061B	3650JA2113P	3650JA2061V	HANDLE,BACK
103B	3650JA2113N	3650JA2113N	3650JA2061A	3650JA2113N	3650JA2061U	HANDLE,BACK
103C	3550J0008F	3550J0008F	3550J0008A	3550J0008C	3550J0008B	COVER,LOWER
105A	5251JA3003D	5251JA3003D	5251JJ2003D	5251JJ2003D	5251JJ2003D	DRAIN ASSEMBLY,PIPE-Z
106A	4779JJ2001B	4779JJ2001B	4779JJ2001B	4779JJ2001B	4779JJ2001B	LEG ASSEMBLY,ADJUST
120B	5208JJ1055A	5208JJ1055A	5208JJ1055A	5208JJ1055A	5208JJ1055A	DUCT,MULTI
135C	3550JA2263A	3550JA2263A	3550JA2263A	3550JA2263A	3550JA2263A	COVER,GRILLE FAN
135D	3551JJ2028A	3551JJ2028A	3551JJ2028A	3551JJ2028A	3551JJ2028A	COVER ASSEMBLY,GRILL FAN
145A	4930JA2080C	4930JA2080C	4930JA2080C	4930JA2080C	4930JA2080C	HOLDER,SHELF
145B	4930JA2081C	4930JA2081C	4930JA2081C	4930JA2081C	4930JA2081C	HOLDER,SHELF
158A	3550JJ1070A	3550JJ1070A	3550JJ1070A	3550JJ1070A	3550JJ1070A	COVER,LAMP
158B	3550JA1386A	3550JA1386A	3550JA1386A	3550JA1386A	3550JA1386A	COVER,LAMP
207A	3550JJ1097J	3550JJ1097J	3550JJ1097A	3550JJ1097E	3550JJ1097C	COVER,HINGE
207B	3550JJ1097K	3550JJ1097K	3550JJ1097B	3550JJ1097F	3550JJ1097D	COVER,HINGE
249C	4930JJ1016B	4930JJ1016B	4930JJ1016B	4930JJ1016B	4930JJ1016B	HOLDER,RAIL
249D	4930JJ1016A	4930JJ1016A	4930JJ1016A	4930JJ1016A	4930JJ1016A	HOLDER,RAIL
262B	4775JJ2017F	4775JJ2017F	4775JJ2017F	4775JJ2017F	4775JJ2017K	HINGE ASSEMBLY,C
262H	4775JJ2017H	4775JJ2017H	4775JJ2017D	4775JJ2017H	4775JJ2017M	HINGE ASSEMBLY,C
271A	4775JJ2014B	4775JJ2014B	4775JJ2014B	4775JJ2014B	4775JJ2014B	HINGE ASSEMBLY,U
271B	4510JA3004A	4510JA3004A	4510JA3004A	4510JA3004A	4510JA3004A	LEVER,HINGE
271C	4775JJ2014A	4775JJ2014A	4775JJ2014A	4775JJ2014A	4775JJ2014A	HINGE ASSEMBLY,U
282F	3806JL1037A	3806JL1037A	3806JL1037A	3806JL1037A	3806JL1037A	DECO,DUCT
283B	4774JJ3002A	4774JJ3002A	4774JJ3002A	4774JJ3002A	4774JJ3002A	HINGE,L
300A	2521C-A5719	2521C-A5719	2521C-A5719	2521C-A5719	2521C-A5719	COMPRESSOR,ASSEMBLY
301A	5421JJ1003B	5421JJ1003B	5421JJ1003B	5421JJ1003B	5421JJ1003B	EVAPORATOR ASSEMBLY
303B	(*)5421JJ1003A	(*)5421JJ1003A	(*)5421JJ1003A	(*)5421JJ1003A	(*)5421JJ1003A	
303C	6748C-0004D	6748C-0004D	6748C-0004D	6748C-0004D	6748C-0004D	P.T.C
303D	6750C-0005P	6750C-0005P	6750C-0005P	6750C-0005P	6750C-0005P	O.L.P
304A	3550JA2042C	3550JA2042C	3550JA2042C	3550JA2042C	3550JA2042C	COVER,P.T.C
310B	5200JA1029A	5200JA1029A	5200JA1029A	5200JA1029A	5200JA1029A	JOINT,PIPE
312A	5040JA3071A	5040JA3071A	5040JA3071A	5040JA3071A	5040JA3071A	RUBBER,SEAT
313A	3551JJ2018A	3551JJ2018A	3551JJ2018A	3551JJ2018A	3551JJ2018A	COVER ASSEMBLY,BACK-M/C
313B	3550JJ2067A	3550JJ2067A	3550JJ2067A	3550JJ2067A	3550JJ2067A	COVER,VALVE
314A	4620JA3015A	4620JA3015A	4620JA3015A	4620JA3015A	4620JA3015A	STOPPER,COMP
315A	3103JJ1001H	3103JJ1001H	3103JJ1001H	3103JJ1001H	3103JJ1001H	COMP BASE ASSEMBLY,STD
315B	4580JA3033A	4580JA3033A	4580JA3033A	4580JA3033A	4580JA3033A	ROLLER
315C	4J04238A	4J04238A	4J04238A	4J04238A	4J04238A	PIN,DRAWING
317A	5851JA2008U	5851JA2008U	5851JA2008U	5851JA2008U	5851JA2008U	DRIER
318A	4930JA3034A	4930JA3034A	4930JA3034A	4930JA3034A	4930JA3034A	HOLDER,DRIER
319A	3390JJ0007B	3390JJ0007B	3390JJ0007B	3390JJ0007B	3390JJ0007B	TRAY,DRIP
319C	4974JJ1036B	4974JJ1036B	4974JJ1036B	4974JJ1036B	4974JJ1036B	GUIDE,FAN
323B	5403JJ1004B	5403JJ1004B	5403JJ1004B	5403JJ1004B	5403JJ1004B	CONDENSER ASSEMBLY,WIRE
327A	4J04328A	4J04328A	4J04328A	4J04328A	4J04328A	RUBBER,DAMPING
328A	4J03020A	4J03020A	4J03020A	4J03020A	4J03020A	RUBBER,DAMPING
329A	5901JA1021A	5901JA1021A	5901JA1021A	5901JA1021A	5901JA1021A	FAN ASSEMBLY
329C	5901JA1013A	5901JA1013A	5901JA1013A	5901JA1013A	5901JA1013A	FAN ASSEMBLY
332A	3530JJ0007A	3530JJ0007A	3530JJ0007A	3530JJ0007A	3530JJ0007A	GRILLE,FAN
400A	6615JB2005H	6615JB2005H	6615JB2005H	6615JB2005H	6615JB2005H	CONTROLLER ASSEMBLY
402A	6600JB3007E	6600JB3007E	6600JB3007E	6600JB3007E	6600JB3007E	SWITCH,[PUSH]
404A	4681JK1004D	4681JK1004D	4681JK1004D	4681JK1004D	4681JK1004D	MOTOR ASSEMBLY,REF FAN
405A	4810JJ0003A	4810JJ0003A	4810JJ0003A	4810JJ0003A	4810JJ0003A	BRACKET,MOTOR
405B	4810JJ2005A	4810JJ2005A	4810JJ2005A	4810JJ2005A	4810JJ2005A	BRACKET,MOTOR
405C	5040JA2009B	5040JA2009B	5040JA2009B	5040JA2009B	5040JA2009B	RUBBER,MOTOR-F
405F	5040JA2004B	5040JA2004B	5040JA2004B	5040JA2004B	5040JA2004B	RUBBER,MOTOR-F
406A	4930JJ3020A	4930JJ3020A	4930JJ3020A	4930JJ3020A	4930JJ3020A	HOLDER,BRACKET
406B	6600JB1010A	6600JB1010A	6600JB1010A	6600JB1010A	6600JB1010A	SWITCH,[PUSH]
406C	4930JA3037A	4930JA3037A	4930JA3037A	4930JA3037A	4930JA3037A	HOLDER,BRACKET
406D	4931JA3006A	4931JA3006A	4931JA3006A	4931JA3006A	4931JA3006A	HOLDER,DOOR
408A	5300JK1005D	5300JK1005D	5300JK1005D	5300JK1005D	5300JK1005D	HEATH,SHEATH
409B	6912JK2002C	6912JK2002C	6912JK2002C	6912JK2002C	6912JK2002C	LAMP,[INCANDESCENT]
409D	(*)6912JB2004K	(*)6912JB2004K	(*)6912JB2004K	(*)6912JB2004K	(*)6912JB2004K	
410A	3034JA1009A	3034JA1009A	3034JA1009A	3034JA1009A	3034JA1009A	REFLECTOR,LAMP
410G	6621JK2002D	6621JK2002D	6621JK2002D	6621JK2002D	6621JK2002D	SOCKET ASSEMBLY,LAMP
411A	0CZZJB2012J	0CZZJB2012J	0CZZJB2012J	0CZZJB2012J	0CZZJB2012J	CAPACITOR,DRAWING
411A	(*)0CZZJB2014D	(*)0CZZJB2014D	(*)0CZZJB2014D	(*)0CZZJB2014D	(*)0CZZJB2014D	
420A	6411JK1006A	6411JK1006A	6411JK1006A	6411JK1006A	6411JK1006A	POWER CORD ASSEMBLY
501A	4681JK1001B	4681JK1001B	4681JK1001B	4681JK1001B	4681JK1001B	MOTOR ASSEMBLY,COOLING
501F	6871JB1280L	6871JB1280L	6871JB1280L	6871JB1280L	6871JB1280L	PWB(PCB) ASSEMBLY,MAIN
503D	3551JA2144D	3551JA2144D	3550JJ1078A	3550JJ1078A	3550JJ1078A	COVER,PWB
610A	3110JJ1014A	3110JJ1014A	3110JJ1014A	3110JJ1014A	3110JJ1014A	CASE,LAMP
610B	3550JA2247A	3550JA2247A	3550JA2247A	3550JA2247A	3550JA2247A	COVER,SENSOR
610C	6500JB2001L	6500JB2001L	6500JB2001L	6500JB2001L	6500JB2001L	SENSOR
624A	6500JB2002P	6500JB2002P	6500JB2002P	6500JB2002P	6500JB2002P	SENSOR
624B	5231JA2006A	5231JA2006A	5231JA2006A	5231JA2006A	5231JA2006A	FILTER ASSEMBLY,WATER
624C	5230JA2003A	5230JA2003A	5230JA2003A	5230JA2003A	5230JA2003A	FILTER(MECH),HEAD
624D	3550JL1018B	3550JL1018B	3550JL1018B	3550JL1018B	3550JL1018B	COVER,FILTER
B01	3550JL1015B	3550JL1015B	3550JL1015B	3550JL1015B	3550JL1015B	COVER,FILTER
B02	4000W4A003A	4000W4A003A	4000W4A003A	4000W4A003A	4000W4A003A	SCREW,DRAWING
B03	1STZJA3004Q	1STZJA3004Q	1STZJA3004D	1STZJA3004Q	1STZJA3004J	SCREW,DRAWING
B04	1STZJA3004F	1STZJA3004F	1STZJA3004F	1STZJA3004F	1STZJA3004F	SCREW,DRAWING
S01	1BZZJA2002A	1BZZJA2002A	1BZZJA2002A	1BZZJA2002A	1BZZJA2002A	BOLT,DRAWING
S02	4J00415D	4J00415D	4J00415D	4J00415D	4J00415D	SCREW,DRAWING
S03	4J00415D	4J00415D	4J00415D	4J00415D	4J00415D	SCREW,DRAWING
S04	4J01424B	4J01424B	4J01424B	4J01424B	4J01424B	SCREW,DRAWING
S05	1SZZJJ3005E	1SZZJJ3005E	1SZZJJ3005E	1SZZJJ3005E	1SZZJJ3005E	SCREW,DRAWING
S06	4J00415D	4J00415D	4J00415D	4J00415D	4J00415D	SCREW,DRAWING
S07	1SBZJA3004L	1SBZJA3004L	1SBZJA3004L	1SBZJA3004L	1SBZJA3004L	SCREW,DRAWING
S08	3J05696W	3J05696W	3J05696W	3J05696W	3J05696W	SCREW,DRAWING
S09	1SZZJJ3005E	1SZZJJ3005E	1SZZJJ3005E	1SZZJJ3005E	1SZZJJ3005E	SCREW,DRAWING
S10	1SZZJJ3010D	1SZZJJ3010D	1SZZJJ3010D	1SZZJJ3010D	1SZZJJ3010E	SCREW,DRAWING
S11	4000W4A003A	4000W4A003A	4000W4A003A	4000W4A003A	4000W4A003A	SCREW,DRAWING
S12	3J05696W	3J05696W	3J05696W	3J05696W	3J05696W	SCREW,DRAWING
S13	1SZZJA3005H	1SZZJA3005H	1SZZJA3005H	1SZZJA3005H	1SZZJA3005J	SCREW,DRAWING
S14	4J00415D	4J00415D	4J00415D	4J00415D	4J00415D	SCREW,DRAWING
S15	4J00415D	4J00415D	4J00415D	4J00415D	4J00415D	SCREW,DRAWING
S16	1SZZJA3016A	1SZZJA3016A	1SZZJA3016A	1SZZJA3016A	1SZZJA3016A	SCREW,DRAWING

CAUTION: Use the part number to order part, not the position number.

FREEZER PARTS

CAUTION: Use the part number to order part, not the position number.

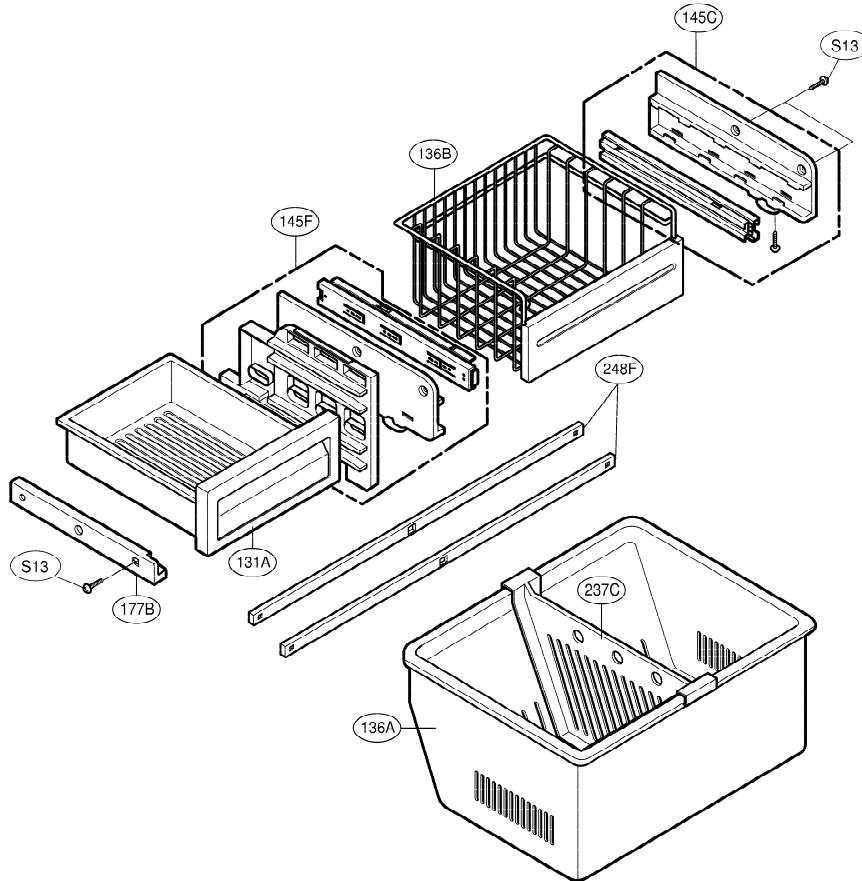

LOC No.	755**	Description
131A	5075JJ2002D	BANK ASSEMBLY,ICE
136A	3390JJ1072A	TRAY,DRAWER
136B	3391JJ2010H	TRAY ASSEMBLY,DRAWER
145C	4975JJ2007E	GUIDE ASSEMBLY,RAIL
145F	4975JJ2005F	GUIDE ASSEMBLY,RAIL
177B	4974JA1127A	GUIDE,RAIL
237C	4974JJ1031A	GUIDE,DRAWER
248F	4980JJ2012A	SUPPORTER,HOLDER
S13	1SZZJJ3005E	SCREW,DRAWING

CAUTION: Use the part number to order part, not the position number.

REFRIGERATOR PARTS

CAUTION: Use the part number to order part, not the position number.

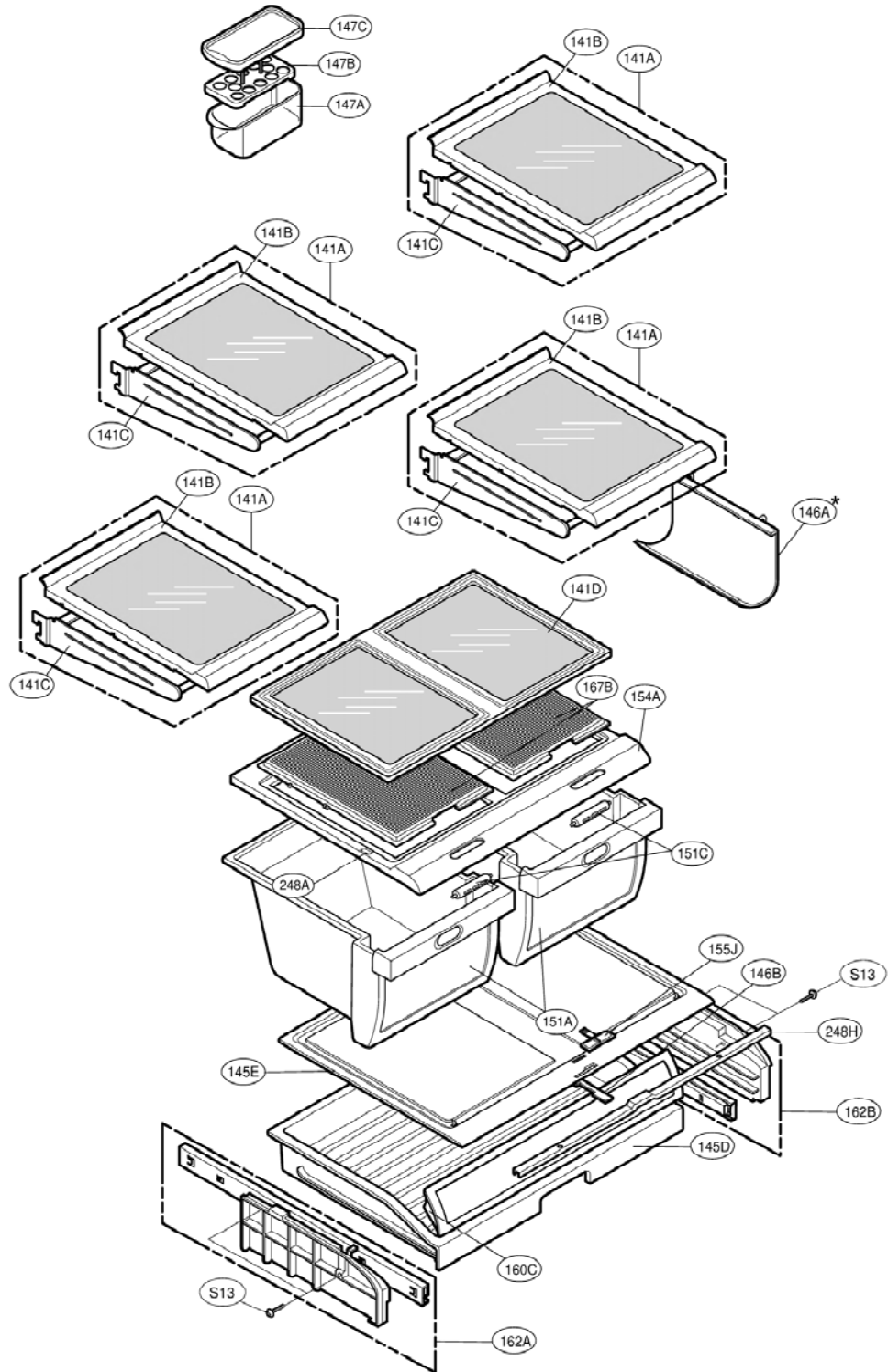

* : on some models

REFRIGERATOR PARTS

LOC No.	7554*	7555*	Description
141A	5027JJ2014D	5027JJ2014D	SHELF ASSEMBLY,R
141B	5026JJ1050B	5026JJ1050B	SHELF,R
141C	5027JJ2012F	5027JJ2012F	SHELF ASSEMBLY,NET
141D	4890JL1012A	4890JL1012A	GLASS, COVER-T/V
145D	3391JJ1030A	3391JJ1030A	TRAY ASSEMBLY,FRESH ROOM
145E	3550JL1010B	3550JL1010B	COVER,TRAY
146A		J469-00030A	WINE,RACK
146B	4520JJ1003A	4520JJ1003A	LINK
147A	5074JJ1016A	5074JJ1016A	BANK,DAIRY
147B	3390JJ1082A	3390JJ1082A	TRAY,EGG
147C	3550JJ1084A	3550JJ1084A	COVER,BANK
151A	3391JJ2014B	3391JJ2014B	TRAY ASSEMBLY,VEGETABLE
151C	4940JA2026C	4940JA2026C	KNOB,SHUTTER
154A	3550JL1016A	3550JL1016A	COVER,T/V
155J	4940JJ2009B	4940JJ2009B	KNOB,SHUTTER
160C	3551JJ2021A	3551JJ2021A	COVER ASSEMBLY,TRAY
162A	4975JJ2016A	4975JJ2016A	GUIDE ASSEMBLY,RAIL
162B	4975JJ2016B	4975JJ2016B	GUIDE ASSEMBLY,RAIL
167B	3550JJ1069A	3550JJ1069A	COVER,MAGIC ROOM
248A	5218JJ3002A	5218JJ3002A	RAIL,SLIDE
248H	4980JJ2014A	4980JJ2014A	SUPPORTER,HOLDER
S13	1SZZJJ3005E	1SZZJJ3005E	SCREW,DRAWING

DOOR PARTS

LOC No.	755*3	755*6	755*2	755*9	755*4	Description
201A	5433JJ0050T	5433JJ0050P	5433JJ0050Q	5433JJ0050S	5433JJ0050R	DOOR FOAM ASSEMBLY,F
203A	4987JA2008J	4987JA2008J	4987JA2008E	4987JA2008J	4987JA2008E	GASKET ASSEMBLY,DOOR
205A	5004JJ1061B	5004JJ1061B	5004JJ1061B	5004JJ1061B	5004JJ1061B	BASKET,DOOR
205B	5004JA2017A	5004JA2017A	5004JA2017A	5004JA2017A	5004JA2017A	BASKET,TILT
205C	5004JA2017B	5004JA2017B	5004JA2017B	5004JA2017B	5004JA2017B	BASKET,TILT
212D	3651JJ2012G	3651JJ2012G	3651JJ2012D	3651JJ2012E	3651JJ2012F	HANDLE ASSEMBLY,F
212G	3846JD2002A	3846JD2002A	3846JD2002A	3846JD2002A	3846JD2002A	MARK
230A	3581JJ8050E	3581JJ8050D	3581JJ8050A	3581JJ8050C	3581JJ8050B	DOOR ASSEMBLY,R/R
230B	3581JJ8051E	3581JJ8051D	3581JJ8051A	3581JJ8051C	3581JJ8051B	DOOR ASSEMBLY,R/L
231A	5433JJ0048M	5433JJ0048H	5433JJ0048J	5433JJ0048L	5433JJ0048K	DOOR FOAM ASSEMBLY,R
231B	5433JJ0053L	5433JJ0053G	5433JJ0053K	5433JJ0053K	5433JJ0053J	DOOR FOAM ASSEMBLY,R
233A	4987JJ2002C	4987JJ2002C	4987JJ2002A	4987JJ2002C	4987JJ2002A	GASKET ASSEMBLY,DOOR
233B	4987JJ2002D	4987JJ2002D	4987JJ2002B	4987JJ2002D	4987JJ2002B	GASKET ASSEMBLY,DOOR
233C	3551JJ2030B	3551JJ2030B	3551JJ2030B	3551JJ2030B	3551JJ2030B	COVER ASSEMBLY,FRONT
233D	3551JJ2030A	3551JJ2030A	3551JJ2030A	3551JJ2030A	3551JJ2030A	COVER ASSEMBLY,FRONT
237A	4974JA2055A	4974JA2055A	4974JA2055A	4974JA2055A	4974JA2055A	GUIDE,BOTTLE
241A	5004JL1006B	5004JL1006B	5004JL1006B	5004JL1006B	5004JL1006B	BASKET,WINDOW
241B	5004JJ1057A	5004JJ1057A	5004JJ1057A	5004JJ1057A	5004JJ1057A	BASKET,DOOR
241C	5005JJ2014A	5005JJ2014A	5005JJ2014A	5005JJ2014A	5005JJ2014A	BASKET ASSEMBLY,DOOR
243A	4620JJ3006C	4620JJ3006C	4620JJ3006A	4620JJ3006C	4620JJ3006B	STOPPER,DOOR
243B	4620JJ2009A	4620JJ2009A	4620JJ2009A	4620JJ2009A	4620JJ2009A	STOPPER,DOOR
244A	3651JJ2011K	3651JJ2011K	3651JJ2011D	3651JJ2011F	3651JJ2011H	HANDLE ASSEMBLY,R
244B	3651JJ2011L	3651JJ2011L	3651JJ2011E	3651JJ2011G	3651JJ2011J	HANDLE ASSEMBLY,R
249A	5098JJ2002L	5098JJ2002L	5098JJ2002L	5098JJ2002L	5098JJ2002L	CONNECTOR ASSEMBLY (MECH)
249B	5098JJ2002M	5098JJ2002M	5098JJ2002M	5098JJ2002M	5098JJ2002M	CONNECTOR ASSEMBLY (MECH)
249E	5218JA1010A	5218JA1010A	5218JA1010A	5218JA1010A	5218JA1010A	CONNECTOR ASSEMBLY (MECH)
249F	5218JA1010B	5218JA1010B	5218JA1010B	5218JA1010B	5218JA1010B	CONNECTOR ASSEMBLY (MECH)
249G	5098JA2001D	5098JA2001D	5098JA2001D	5098JA2001D	5098JA2001D	CONNECTOR ASSEMBLY (MECH)
249H	5098JA2001C	5098JA2001C	5098JA2001C	5098JA2001C	5098JA2001C	CONNECTOR ASSEMBLY (MECH)
262C	4350JA3005B	4350JA3005B	4350JA3005B	4350JA3005B	4350JA3005B	RING
281C	4811JJ2015A	4811JJ2015A	4811JJ2015A	4811JJ2015A	4811JJ2015A	BRACKET ASSEMBLY,DOOR
281E	3550JA2267A	3550JA2267A	3550JA2267A	3550JA2267A	3550JA2267A	COVER,HINGE
281F	3550JA2264A	3550JA2264A	3550JA2264A	3550JA2264A	3550JA2264A	COVER,HINGE
312B	3550JL1014A	3550JL1014A	3550JL1014A	3550JL1014A	3550JL1014A	COVER,FRONT
312C	5006JA3016C	5006JA3016C	5006JA3016C	5006JA3016C	5006JA3016C	CAP,DUCT
615A	4838JA2002B	4838JA2002B	4838JA2002B	4838JA2002B	4838JA2002B	TANK ,WATER
B05	4620JJ3007B	4620JJ3007B	4620JJ3007B	4620JJ3007B	4620JJ3007B	STOPPER,HANDLE
B06	4620JJ3007B	4620JJ3007B	4620JJ3007B	4620JJ3007B	4620JJ3007B	STOPPER,HANDLE
B07	1STZJA3001B	1STZJA3001B	1STZJA3001B	1STZJA3001B	1STZJA3001B	SCREW,DRAWING
S25	1SZZJA3011D	1SZZJA3011D	1SZZJA3011D	1SZZJA3011D	1SZZJA3011D	SCREW,DRAWING
S26	J471-00001J	J471-00001J	J471-00001J	J471-00001J	J471-00001J	SCREW,DRAWING
S34	1SZZJJ3011C	1SZZJJ3011C	1SZZJJ3011C	1SZZJJ3011C	1SZZJJ3011C	SCREW,DRAWING

CAUTION: Use the part number to order part, not the position number.

DOOR PARTS

CAUTION: Use the part number to order part, not the position number.

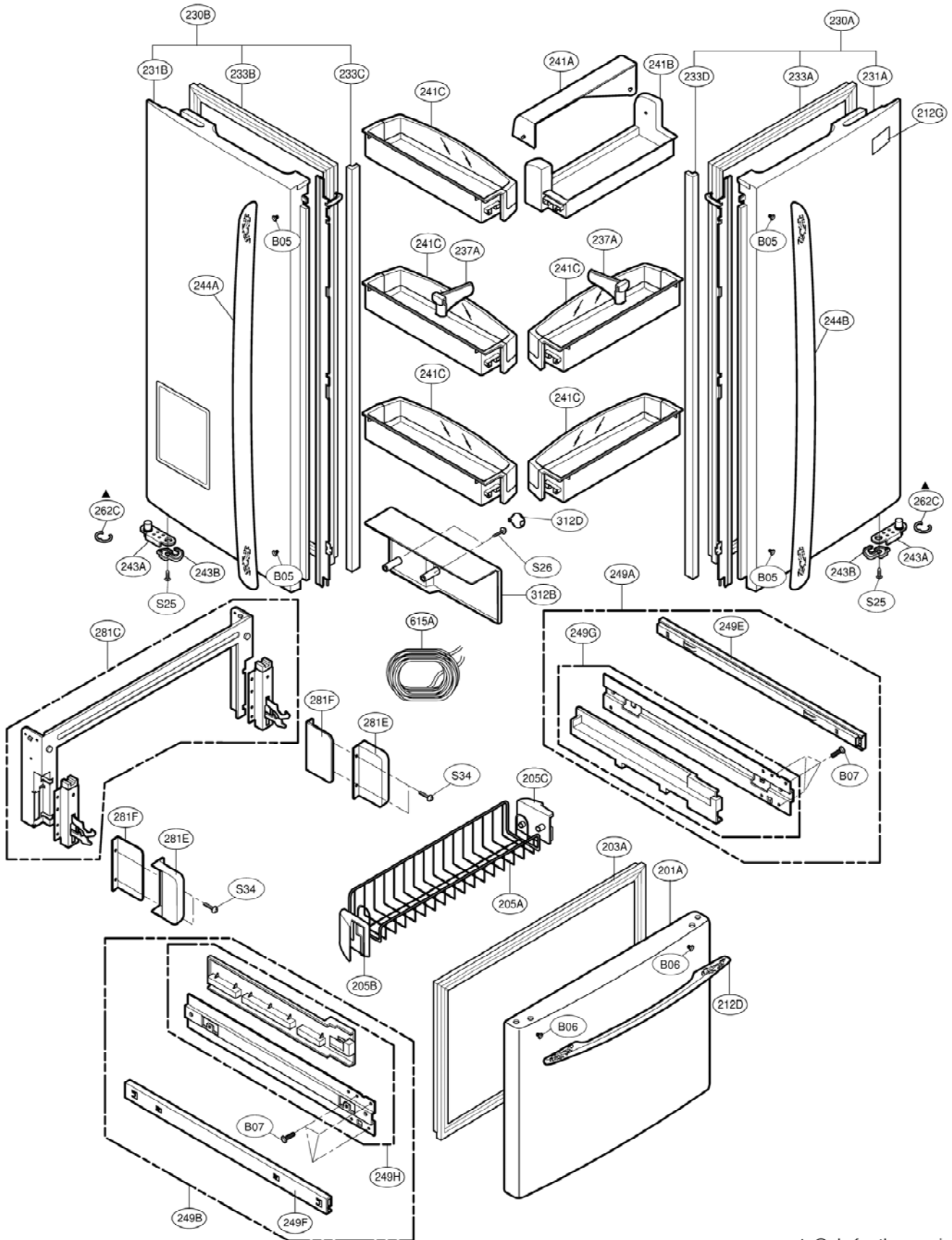

▲ Only for the service

DISPENSER PARTS

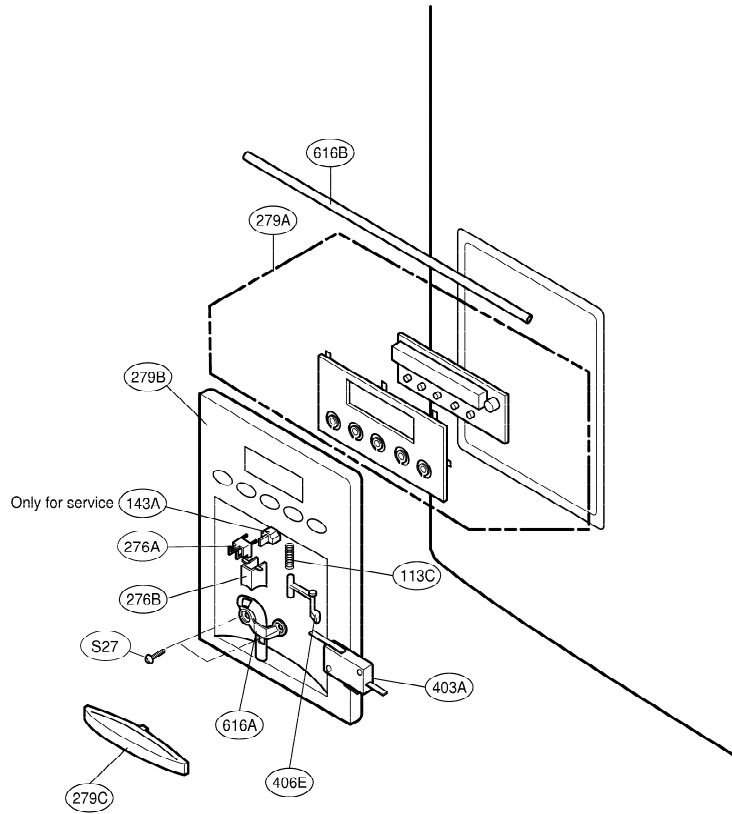

LOC No.	755*3	755*6	755*2	755*9	755*4	Description
113C	4970JJ3004A	4970JJ3004A	4970JJ3004A	4970JJ3004A	4970JJ3004A	SPRING,W
143A	4620JA3026A	4620JA3026A	4620JA3026A	4620JA3026A	4620JA3026A	STOPPER,SLIDE
276A	4930JJ3016A	4930JJ3016A	4930JJ3016A	4930JJ3016A	4930JJ3016A	HOLDER,BUTTON
276B	5020JJ3001C	5020JJ3001C	5020JJ3001A	5020JJ3001C	5020JJ3001A	BUTTON,LEVER
279A	3211JJ2001C	3211JJ2001C	3211JJ2001A	3211JJ2001C	3211JJ2001D	FRAME ASSEMBLY,DISPLAY
279B	3550JL1020B	3550JL1020B	3550JL1020A	3550JL1020C	3550JL1020D	COVER,DISPENSER
279C	3806JJ2053B	3806JJ2053B	3806JJ2053A	3806JJ2053C	3806JJ2053D	DECO,DRAIN
403A	6600JB3001B	6600JB3001B	6600JB3001B	6600JB3001B	6600JB3001B	SWITCH(MICRO)
406E	4510JA3014A	4510JA3014A	4510JA3014A	4510JA3014A	4510JA3014A	LEVER,DISPENSER
616A	5210JJ3008C	5210JJ3008C	5210JJ3008A	5210JJ3008C	5210JJ3008A	TUBE,INJECT
616B	5210JA3005H	5210JA3005H	5210JA3005H	5210JA3005H	5210JA3005H	TUBE,PE
S27	4J00415D	4J00415D	4J00415D	4J00415D	4J00415D	SCREW,DRAWING



*'You Can Count on me . . .
to Work Safely.'*