

This Owner's Manual is provided and hosted by [Appliance Factory Parts](http://www.appliancefactoryparts.com).

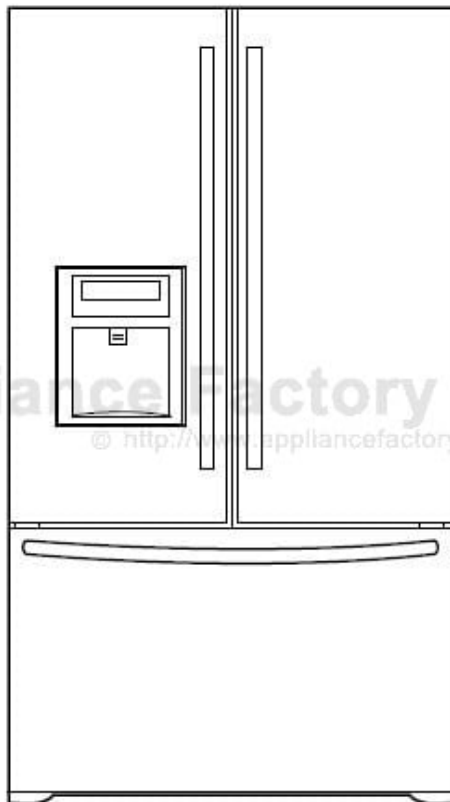

Kenmore 795.78416.800 Owner's Manual

[Shop genuine replacement parts for Kenmore
795.78416.800](#)



[Find Your Kenmore Refrigerator Parts - Select From 665 Models](#)

----- Manual continues below -----



REFRIGERATOR

SERVICE MANUAL

CAUTION
BEFORE SERVICING THE UNIT,
READ THE SAFETY PRECAUTIONS IN THIS MANUAL.

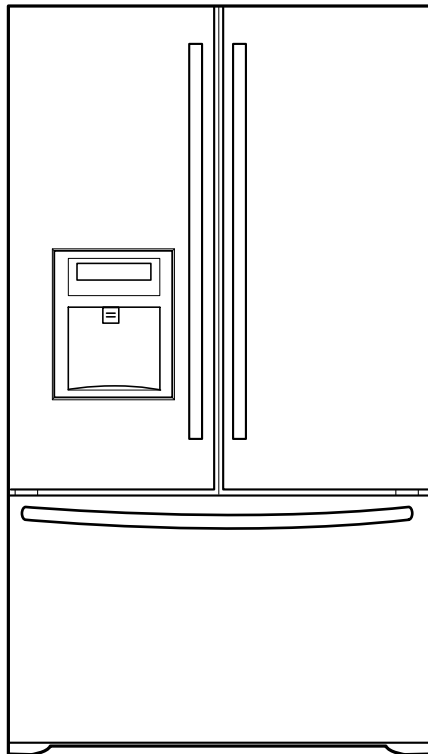

MODELS:

795.78402.800
795.78403.800
795.78406.800
795.78409.800
795.78412.800
795.78413.800
795.78416.800
795.78419.800

CONTENTS

SAFETY PRECAUTIONS	2
1. SPECIFICATIONS	3
2. PARTS IDENTIFICATION	5
3. DISASSEMBLY	6
3.1 Door	8
3.2 Door alignment	8
3.3 Fan and fan motor	8
3.4 Defrost control assembly	9
3.5 Lamp	9
3.6 Multi duct	10
3.7 Main PWB.....	10
3.8 Dispenser.....	10
3.9 Display PWB replacement	10
3.10 Sub PWB for working dispenser	11
3.11 Duct door replacement	11
3.12 Ice corner door replacement	11
3.13 Icemaker assembly	11
3.14 Auger motor cover	12
3.15 How to remove a door ice bin	13
3.16 How to insert a door ice bin	13
3.17 How to remove and reinstall the pull out drawer	14
3.18 Fan and fan motor disassembly method	16
3.19 Glide out drawer	16
3.20 Cover Valve	17
4. ADJUSTMENT	18
4.1 Compressor	18
4.2 PTC-Starter	18
4.3 OLP (Overload Protector)	19
4.4 To remove the cover PTC	19
5. CIRCUIT DIAGRAM	20
6. TROUBLESHOOTING	21
6.1 Compressor and electrical components	21
6.2 Other electrical components	22
6.3 Service diagnosis chart	23
6.4 Refrigeration cycle	24
7. OPERATION PRINCIPLE AND REPAIR METHOD OF ICEMAKER	26
7.1 Operation principle	26
7.2 Ice maker functions	27
7.3 Defect diagnosis function	28
8. DESCRIPTION OF FUNCTION & CIRCUIT OF MICOM	29
8.1 Function	29
8.2 PCB function	35
8.3 Troubleshooting	40
8.4 Main PWB assembly and parts list	42
9. EXPLODED VIEW AND REPLACEMENT PART LIST	44

SAFETY PRECAUTIONS

Please read the following instructions before servicing your refrigerator.

1. Unplug the power before handling any electrical components.
2. Check the rated current, voltage, and capacity.
3. Take caution not to get water near any electrical components.
4. Use exact replacement parts.
5. Remove any objects from the top prior to tilting the product.

1. SPECIFICATIONS

1-1 DISCONNECT POWER CORD BEFORE SERVICING IMPORTANT – RECONNECT ALL GROUNDING DEVICES

All parts of this appliance capable of conducting electrical current are grounded. If grounding wires, screws, straps, clips, nuts or washers used to complete a path to ground are removed for service, they must be returned to their original position and properly fastened.

1-2 IMPORTANT NOTICE

This information is intended for use by individuals possessing adequate backgrounds of electrical, electronic and mechanical experience. Any attempt to repair a major appliance may result in personal injury and property damage. The manufacturer or seller cannot be responsible for the interpretation of this information, nor can it assume any liability in connection with its use.

1-3 ELECTRICAL SPECIFICATIONS

Temperature Control (F)-6°F to +8°F
 Defrost Control.....Adjustable
 Defrost Thermostat.....46°F
 Electrical Rating : 115VAC, 60Hz.....1-5 A
 Maximum Current Leakage.....0.5 mA
 Maximum Ground Path Resistance0.14 Ohms
 Energy Consumption23 cu.ft. 538 kWh/yr (Energy Star)

1-4 NO LOAD PERFORMANCE CONTROL POSITION: MID/MID

And Ambient of:70°F.....90°F
 Fresh Food, °F.....33°F to 41°F.....33°F to 41°F
 Frozen Food, °F.....-4°F to +4°F.....-4°F to +4°F
 Percent Running Time35%-45%50°F-70°F

1-5 REFRIGERATION SYSTEM

Minimum Compressor Capacity Vacuum 21 MIN.
 Minimum Equalized Pressure
 @ 70°F 49 PSIG
 @ 90°F 56 PSIG
 Refrigerant R134a 4.2 oz.
 Compressor 956 BTU/hr

1-6 INSTALLATION

Clearance must be provided at top, sides and rear of the refrigerator for air circulation.

AT TOP 2 in
 AT SIDES 1 in
 AT REAR 1 in

1-7 REPLACEMENT PARTS

Relay	6748C-0004D
Overload	6750C-0004R
Defrost Thermostat	6615JB2005C
Defrost Heater	5300JB1100J
Evaporator Fan Motor	EAU52096201
Capacitor (Running)	0CZZJB2012K
Compressor (Hi-Side)	TCA31748001
Evaporator (Lo-Side)	5421JJ1001B
Condenser	5403JJ1007A
Dryer	5851JJ2002F
Condenser Fan Motor	4681JB1029J
Temperature Control	EBR43358501
Main Control	EBR41956101
Ice Fan Motor	EAU50611501
Duct Assy, Connector (Ice Fan Motor)	ADJ36834101

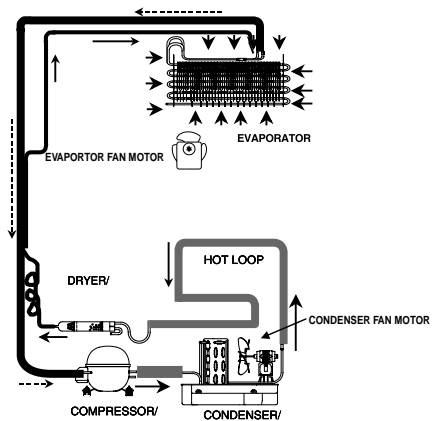

AIR FLOW

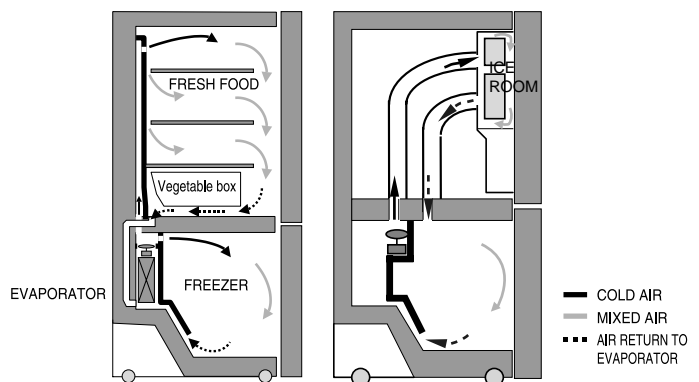

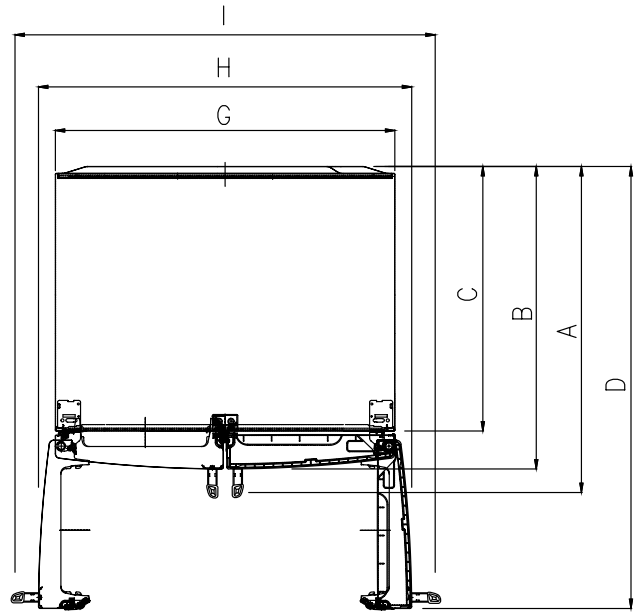
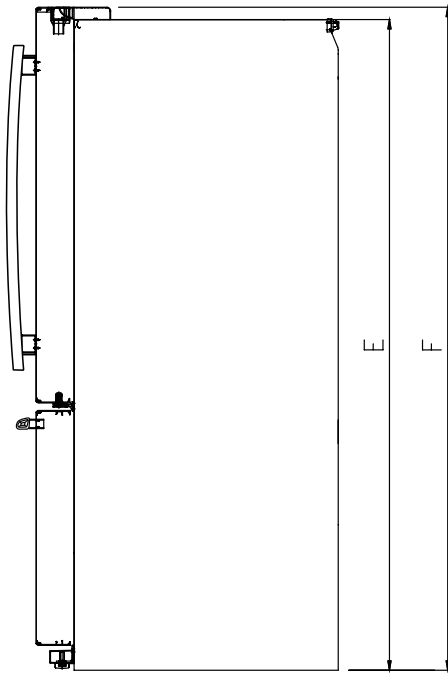

Description		795.775**
Depth w/ Handles	A	34 1/4 in
Depth w/ Handles	B	31 3/4 in
Depth w/ o Door	C	27 7/8 in
Depth (Total with Door Open)	D	46 1/2 in
Height to Top of Case	E	68 3/8 in
Height to Top of Door Hinge	F	69 3/4 in
Width	G	35 3/4 in
Width (door open 90 deg. w/o handle)	H	39 1/4 in

2. PARTS IDENTIFICATION

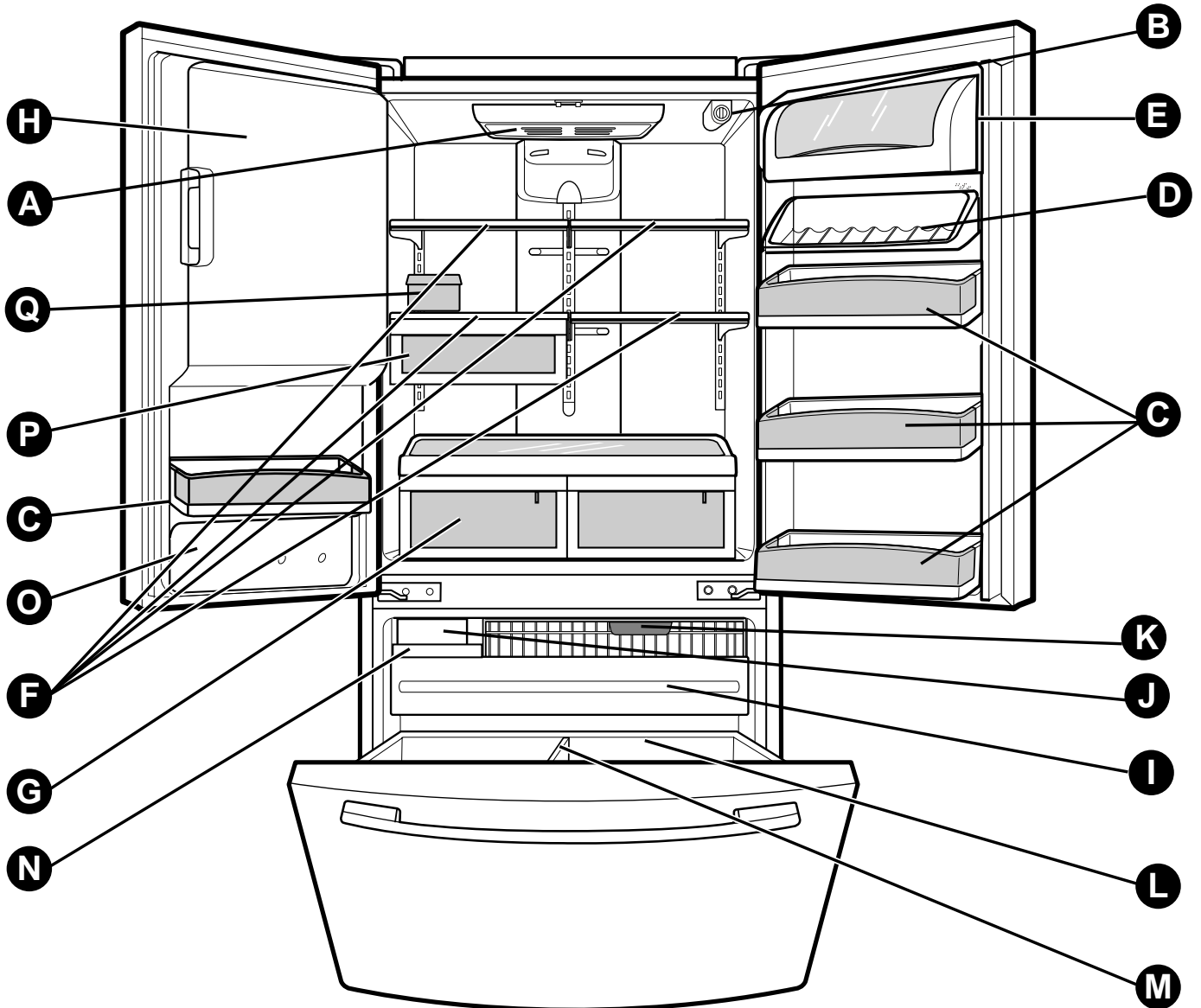

Use this page to become more familiar with the parts and features. Page references are included for your convenience.

NOTE: This guide covers several different models. The refrigerator you have purchased may have some or all of the items listed below. The locations of the features shown below may not match your model.

- | | |
|-------------------------------|---------------------------|
| A Refrigerator Light | J Turbo Motor |
| B Filter (Inside) | K Freezer light |
| C Modular Door Bins | L Durabase |
| D Can Rack* | M Divider |
| E Dairy Bin | N Ice Bin |
| F Refrigerator Shelves | O Water Tank Cover |
| G Crisper | P Snack Pan |
| H Ice Room | Q Egg Box |
| I Glide out Drawer | |

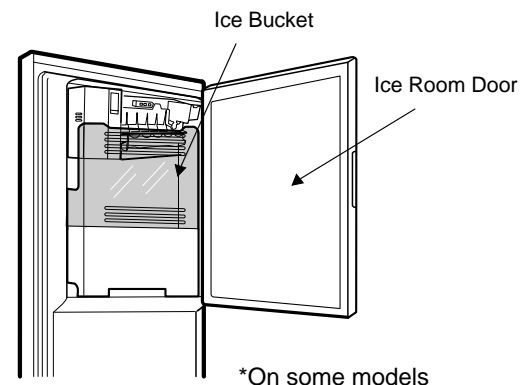

3. DISASSEMBLY

3-1 DOORS

1. Removing Refrigerator Door

NOTE: Handle appearance may vary.

IMPORTANT: Before you begin, turn the refrigerator OFF and unplug it. Remove food and any bins from doors.

► Left Door

- Loosen the screws and remove the cove on back side (see figure A).
- Disconnect water supply tube by pushing back on the disconnect ring (3).
- Loosen the cover screw (1).
- Disconnect door switch wire (2).
- Pull out the tube (4).

⚠ CAUTION: If a tube end is deformed or worn out, cut the damaged portion away.

- Disconnect wire harness (5).
- Remove the ground screw (6).
- Loosen screws (7) and lift off the top hinge (8).
- Place the door on a non-scratching surface with the inside up.

⚠ CAUTION: When removing top hinge, be careful that the door does not fall forward.

► Right Door

- Loosen the cover screw (1).
- Disconnect door switch wire (2).
- Loosen screws (7) and lift off the top hinge (8).
- Place the door on a non-scratching surface with the inside up.

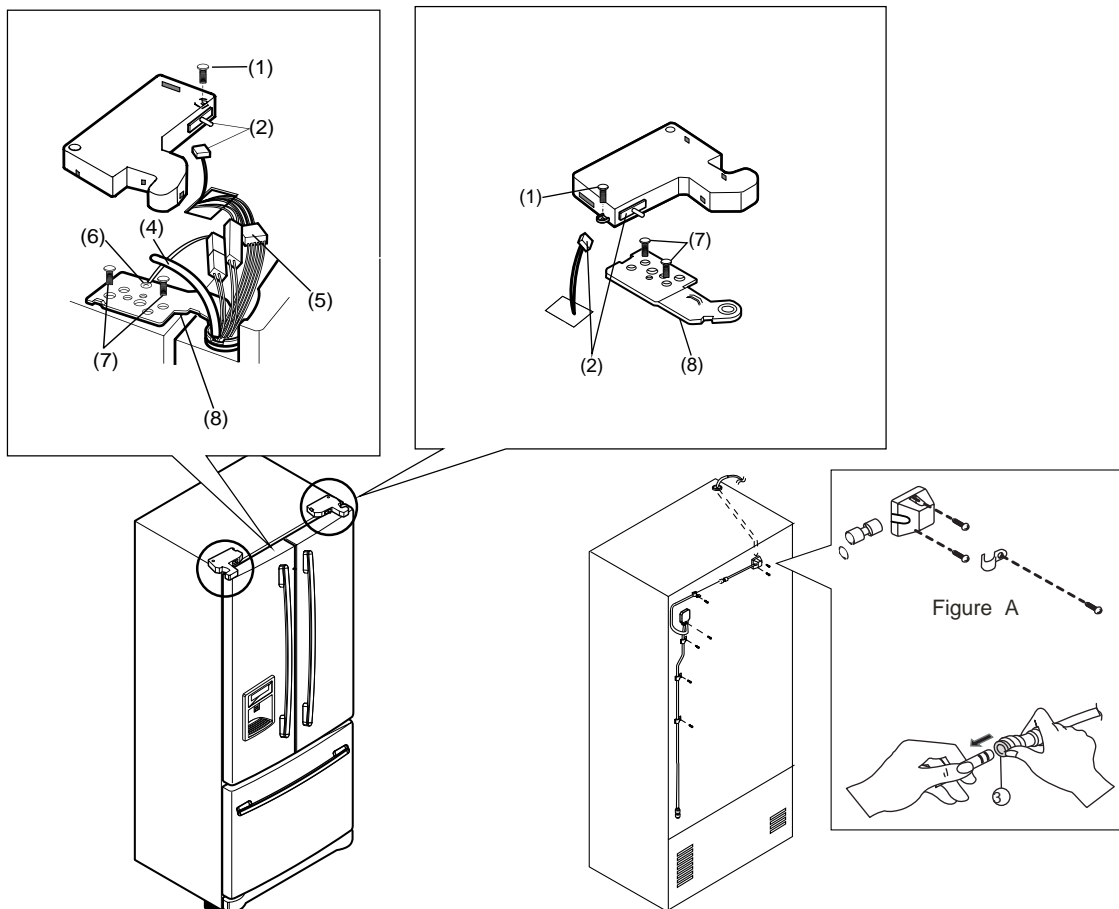

Door Gasket Removal

1. Remove door frame cover

Starting at top of cover and working down, snap cover out and away from door.

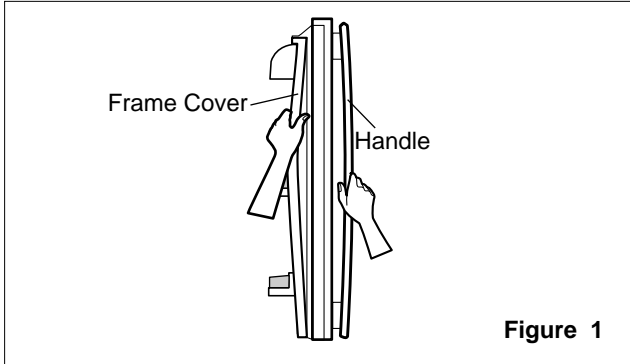

2. Remove gasket bracket clips

There are two clips on each door. Start bracket removal near one of the middle clips.

- 1) Pull gasket back to expose gasket bracket clip and door frame.
- 2) Insert a flat tip screwdriver into seam between gasket bracket and door frame and pry back until clips snap out.
- 3) Continue prying back along seam until all clips snap out.

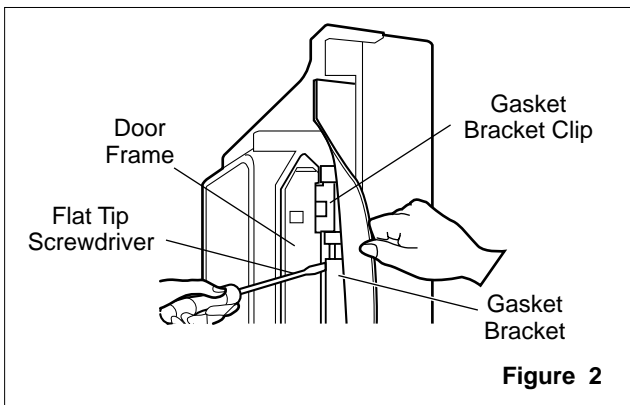

3. Remove gasket

Pull gasket free from gasket channel on the three remaining sides of door.

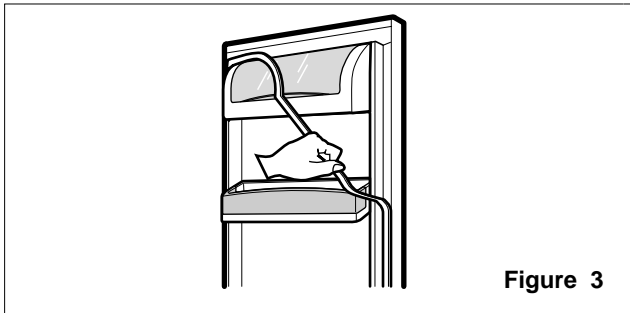

Door Gasket Replacement

1. Insert gasket bracket clips

- 1) Insert gasket bracket edge beneath door frame edge.
- 2) Turn upper gasket bracket spring so that the spring ends are in the door channel.
- 3) Push in clip until you hear it snap securely into place.

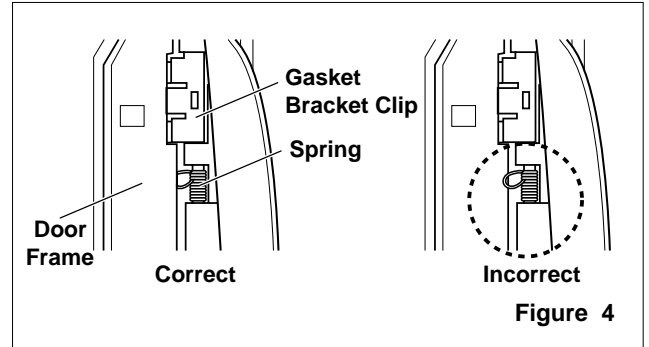

- 4) Push in remaining clip until you hear it snap securely into place.

Note: Make sure that no part of gasket bracket edge protrudes from beneath door frame edge.

2. Insert gasket into channel

- 1) Snap gasket assembly into the door bracket.

<Inserting the Gasket Assembly into the Bracket Door>

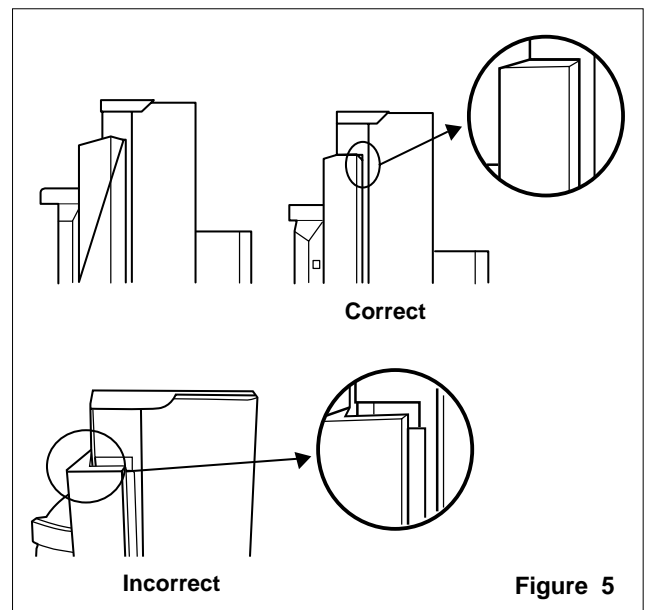

- 2) Press gasket into channels on the three remaining sides of door.

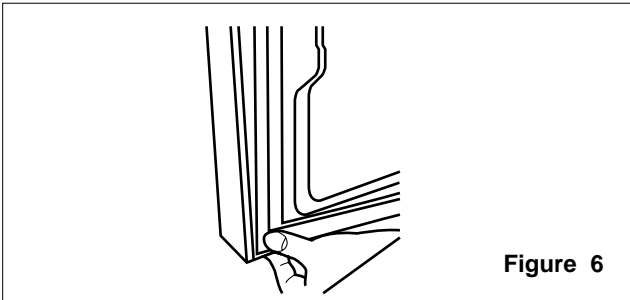

Figure 6

3. Replace door frame cover

Starting at top of cover and working down, snap cover back into door.

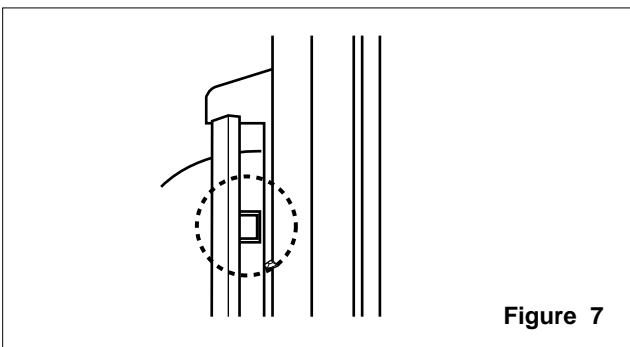

Figure 7

3-2 DOOR ALIGNMENT

If the space between your doors is uneven, follow the instructions below to align the doors:

1. With one hand, lift up the door you want to raise at middle hinge.
2. With other hand, use pliers to insert snap ring as shown.
3. Insert additional snap rings until the doors are aligned. (Three snap rings are provided with unit.)

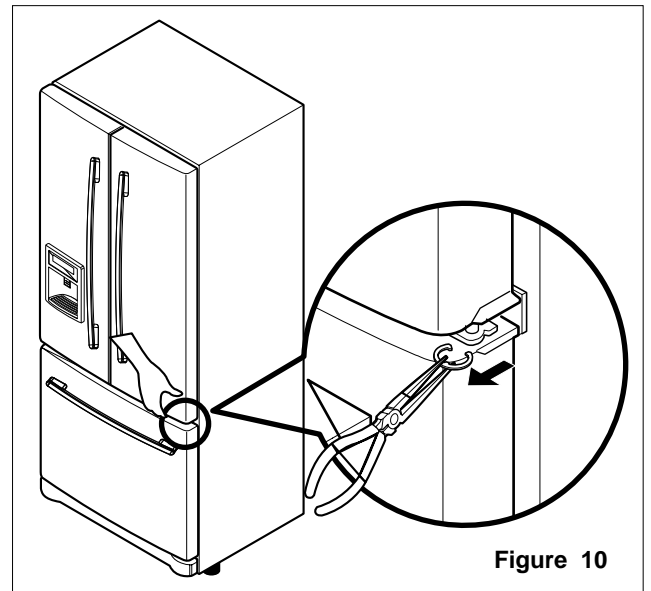

Figure 10

3-3 FAN AND FAN MOTOR(EVAPORATOR)

1. Remove the freezer shelf. (If your refrigerator has an icemaker, remove the icemaker first)
2. Remove the plastic guide for slides on left side by unscrewing phillips head screws.
3. Remove the grille by pulling the grille fan forward.
4. Remove the Fan Motor assembly by loosening 2 screws and disassembling the shroud.
5. Pull out the fan and separate the Fan Motor and Bracket.

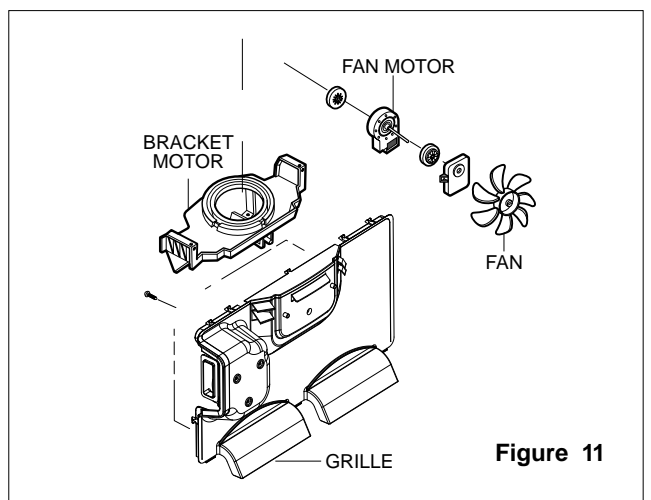

Figure 11

* Ice Fan Scroll Assembly Replacement

- 1) Remove the plastic guide for slides on left side by unscrewing phillips head screws.
- 2) Pull the grille forward as shown in the second picture.
- 3) Disconnect wire harness of the grille
- 4) Remove the scroll assembly by loosening 3 screws



(1)



(2)



(3)



(4)

3-4 DEFROST CONTROL ASSEMBLY

Defrost Control assembly consists of Defrost Sensor and FUSE-M.

The Defrost Sensor works to defrost automatically. It is attached to the metal side of the Evaporator and senses its temperature. At 72°C, it turns the Defrost Heater off.

Fuse-M is a safety device for preventing over-heating of the Heater when defrosting.

1. Pull out the grille assembly. (Figure 12)
2. Separate the connector with the Defrost Control assembly and replace the Defrost Control assembly after cutting the Tie Wrap. (Figure 13)

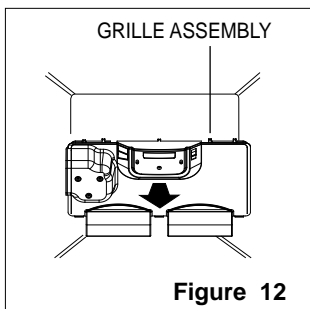

Figure 12

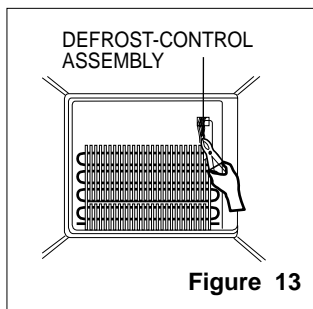

Figure 13

3-5 LAMP

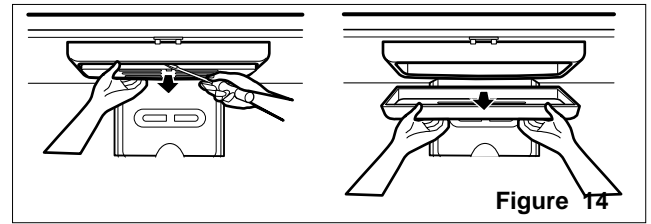

Figure 14

3-5-1 Refrigerator Compartment Lamp

1. Unplug Refrigerator, or disconnect power at the circuit breaker.
2. If necessary, remove top shelf or shelves.
3. Using a flat instrument, gently pry the cover loose in the front as shown. Rotate downward to remove rear tabs.
4. Make sure the bulbs are cool to the touch. Turn bulbs counterclockwise to remove.
5. Assemble in reverse order by snapping the Lamp Cover in, engaging the rear tabs followed by the front tabs. (Max. 60 W-2EA)

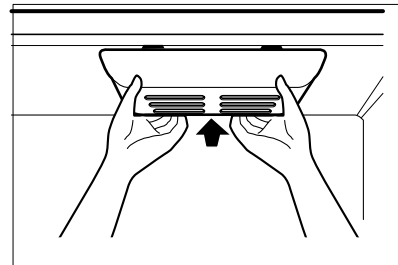

Figure 15

3-5-2 Freezer Compartment Lamp

1. Unplug refrigerator power cord from outlet.
2. Gently pry the lamp cover loose in the back as shown. Rotate forward to remove the front tabs.
3. Make sure the bulb is cool to the touch. Turn the bulb counterclockwise to remove.
4. Replace with a new 60-watt appliance bulb.
5. Insert tabs on front of cover into slots in freezer ceiling. Push cover up to snap back into place.

3-6 MULTI DUCT

1. Remove the upper and lower Caps by using a flat screwdriver, and remove 2 screws. (Figure 17)
2. Disconnect the lead wire on the bottom position.

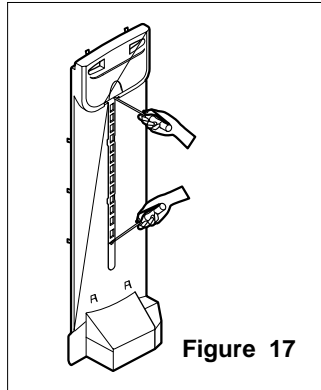

3-7 MAIN PWB

- 1) Loosen the 3 screws on the PWB cover.



- 2) Remove the PWB cover



- 3) Disconnect wire harness and replace the main PWB in the reverse order of removal.



3-8 DISPENSER

- 1) Disconnect funnel and button assembly by pulling down and forward.



- 2) Remove display frame assembly by making a gap between a display frame assembly and door with a flat blade screwdriver and pulling it forward. The cover dispenser is attached with a hook.



- CAUTION:** When replacing the dispenser cover in the reverse order of removal, be careful that the lead wire does not come out and the water tube is not pinched by the dispenser cover, as shown in the picture below.

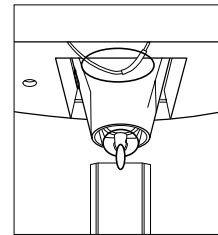

3-9 DISPLAY PWB REPLACEMENT

- 1) Pull up and out on the dispenser cover to remove.



- 2) Follow the steps in the pictures



3-10 FUNNEL REPLACEMENT

- 1) Pull up and out on the dispenser cover to remove.
- 2) Disconnect the wire harness.
- 3) Replace in reverse order.



3-10 SUB PWB FOR WORKING DISPENSER

- 1) Loosen the screw on the sub PWB.



- 2) Pull the sub PWB down.
- 3) Disconnect the wire harness and replace the sub PWB in the reverse order of removal.

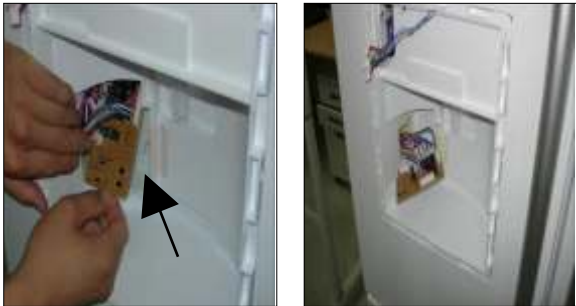

3-11 DUCT DOOR REPLACEMENT

- 1) Pull up and out on the dispenser cover to remove.
- 2) Disconnect the wire harness.
- 3) Remove the funnel
- 4) Replace in reverse order.



3-12 ICE CORNER DOOR REPLACEMENT

- 1) Loosen the front screw as shown in the picture.
- 2) Lift up the hinge with one hand.
- 3) Pull out the Ice Corner Door with the other hand.



3-13 ICEMAKER ASSEMBLY

- 1) Loosen two screws as shown in the first picture.



- 2) Disconnect the wire harness & ground screw replace the icemaker assembly in the reverse order of removal.



- 3) It separates a ground connection screw.



3-14 AUGER MOTOR COVER

1) After removing the icemaker remove the (5) stainless screws holding the auger motor cover, shown in the pictures below.



2) Grip the bottom of motor cover assembly and pull out it.



3) Disconnect wire harness of motor cover assembly. There is a auger motor on the back, as shown in the picture.



Auger Motor

3-15 HOW TO REMOVE A DOOR ICE BIN

1) Grip the handles, as shown in the picture.

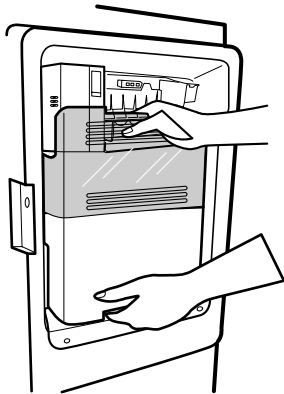

2) Lift the lower part slightly.

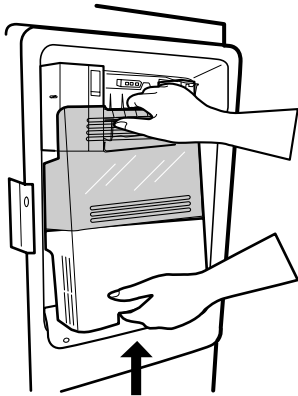

3) Take the Ice Bin out slowly.

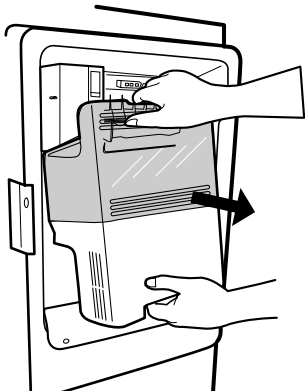

3-16 HOW TO INSERT A DOOR ICE BIN

1) Insert the Ice Bin, slightly tilting it to avoid touching the Icemaker. (especially, ice maker lever)

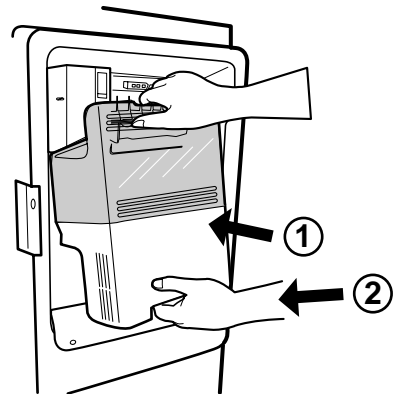

※ Insert the ice bucket carefully avoid contacting the automatic shut off arm.

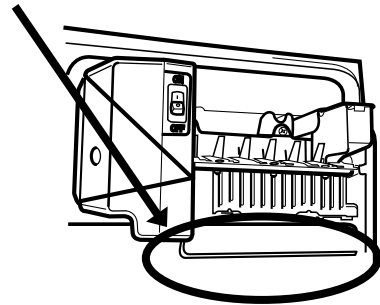

3-17 HOW TO REMOVE AND REINSTALL THE PULLOUT DRAWER

3-19-1 Follow Steps to Remove

Step 1) Open the freezer door.



Step 2) Remove the lower basket.



Step 3) Remove the two screws from the guide rails (one from each side).

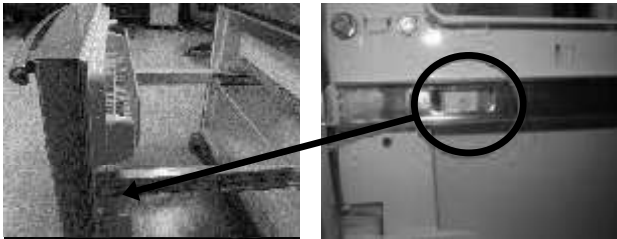

Step 4) Lift the freezer door up to unhook it from the rail support and remove. Pull both rails to full extension.



Step 5) First: Remove the gear from the left side first by releasing the tab behind the gear, place a screwdriver between the gear and the tab and pull up on the gear.

Second: Remove the center rail.

Third: Remove the gear from the right side by following the same steps for the left side.

NOTE: THIS TAB MUST BE PUSHED IN TO RELEASE THE GEAR.

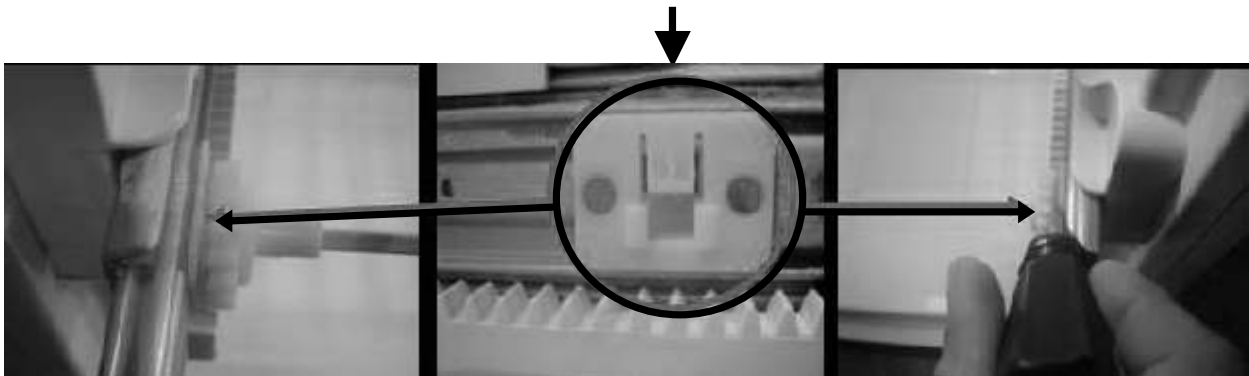

3-17-2 Follow Steps to Reinstall

Step 1) Reinstall the right side gear into the clip.



Step 2) Insert the rail into the right side gear. Gears do **not** need to be perpendicular to each other.



Step 3) Insert the rail into the left side gear, and insert the gear into the clip.



Step 4) The rail system will align itself by pushing the rails all the way into the freezer section. Pull the rails back out to full extension.



Step 5) Reinstall the freezer door by inserting the rail tabs into the guide rail.



Step 6) Reinstall the two screws into the guide rails (one from each side).

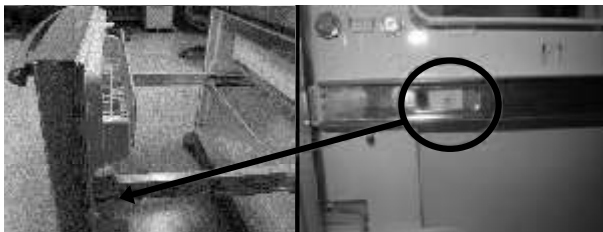

Step 7) Reinstall the lower basket, and close the freezer door.



3-18 FAN AND FAN MOTOR DISASSEMBLY METHOD

- 1) Using a short screwdriver, loosen one SCREW in DRAIN PIPE ASSEMBLY and one connected to the MOTOR COVER.



- 2) Pull and separate the FAN ASSEMBLY and MOTOR turning counterclockwise based on the MOTOR SHAFT.

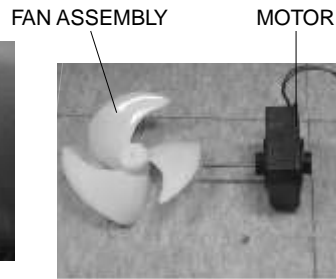

The assembly is in the reverse order of the disassembly and take special care for the following details.

1. Be careful not to bend the tube during assembly.
2. Press the WATER DISPENSER button until water pours out and check for leakage in the CONNECTOR TUBE (It differs by the water pressure but usually takes about 2 minutes until water pours out.)

3-19 GLIDE OUT DRAWER

1. To remove, lift basket up and pull out straight out.

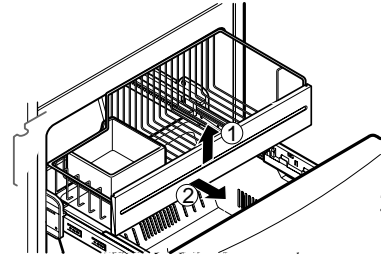

2. To Install, pull both rails out to full extension. Hook the basket supports into the rail tabs and push to the back of compartment.

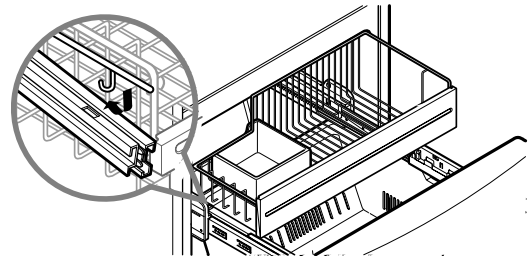
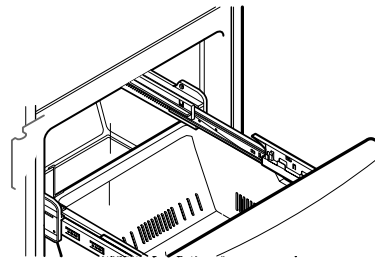

3-20 Cover Valve
- Disassemble

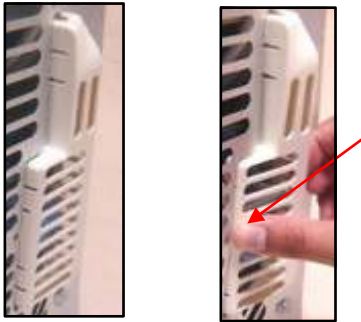

1. Push to inside the cover valve.



2. Push to the right and release.

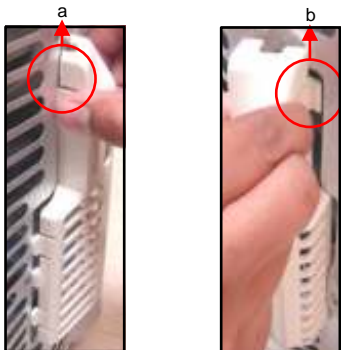

3. Release hook a & b



4. Turn the cover valve 120° as shown in the picture, then release it.

- Assemble

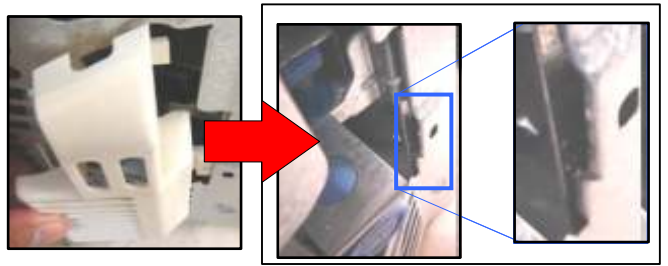

1. Insert the cover valve as shown in the picture, push to insert (may need force).

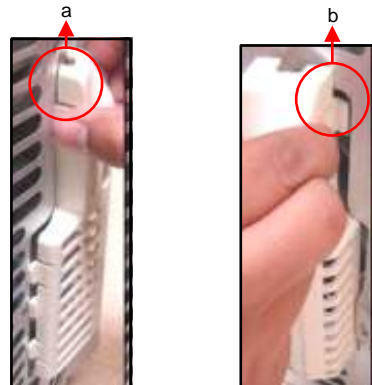

2. Insert hook a & b



3. Push to the right to insert the cover valve.

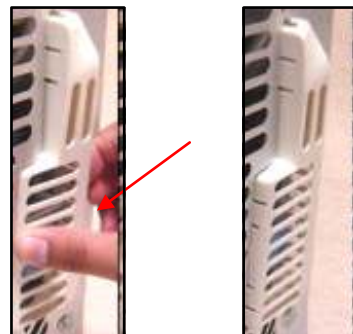

4. Then push to inside to assembly.

4. ADJUSTMENT

4-1 COMPRESSOR

4-1-1 Role

The compressor intakes low temperature and low pressure gas from the evaporator of the refrigerator and compresses this gas to high-temperature and high-pressure gas. It then delivers the gas to the condenser.

4-1-2 Composition

The compressor includes overload protection. The PTC starter and OLP (overload protector) are attached to the outside of the compressor. Since the compressor is manufactured to tolerances of 1 micron and is hermetically sealed in a dust and moisture-free environment, use extreme caution when performing repairs.

4-1-3 Note for Usage

- (1) Be careful not to allow over-voltage and over-current.
- (2) If compressor is dropped or handled carelessly, poor operation and noise may result.
- (3) Use proper electric components appropriate to the Particular Compressor in your product.
- (4) Keep Compressor dry.
If the Compressor gets wet (in the rain or a damp environment) and rust forms in the pin of the Hermetic Terminal, poor operation and contact may result.
- (5) When replacing the Compressor, be careful that dust, humidity, and soldering flux don't contaminate the inside of the compressor. Dust, humidity, and solder flux contaminate the cylinder and may cause noise, improper operation or even cause it to lock up.

4-2 PTC-STARTER

4-2-1 Composition of PTC-Starter

- (1) PTC (Positive Temperature Coefficient) is a no-contact semiconductor starting device which uses ceramic material consisting of BaTiO₃.
- (2) The higher the temperature is, the higher the resistance value. These features are used as a starting device for the Motor.

4-2-2 Role of PTC-Starter

- (1) The PTC is attached to the Sealed Compressor and is used for starting the Compressor Motor.
- (2) The compressor is a single-phase induction motor. The starting operation, the PTC allows current flow to both the start winding and main winding.

4-2-3 PTC-Applied Circuit Diagram Starting Method for the Motor

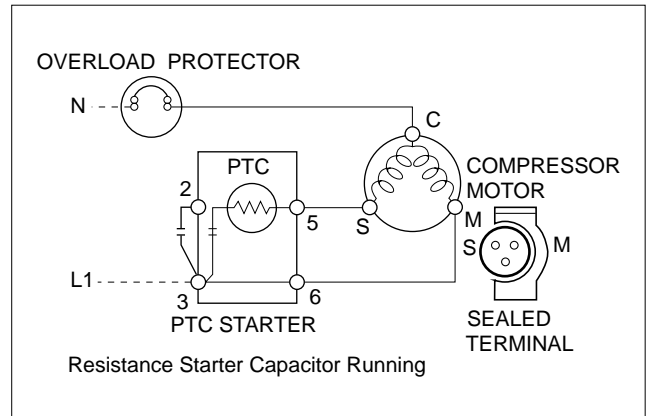

4-2-4 Motor Restarting and PTC Cooling

- (1) It requires approximately 5 minutes for the pressure to equalize before the compressor can restart.
- (2) The PTC device generates heat during operation. Therefore, it must be allowed to cool before the compressor can restart.

4-2-5 Relation of PTC-Starter and OLP

- (1) If the compressor attempts to restart before the PTC device is cooled, the PTC device will allow current to flow only to the main winding.
- (2) The OLP will open because of the over current condition. This same process will continue (3 to 5 times) when the compressor attempts to restart until the PTC device has cooled. The correct OLP must be properly attached to prevent damage to the compressor.
Parts may appear physically identical but could have different electrical ratings. Replace parts by part number and model number. Use only approved substitute parts.

4-2-6 Note for Using the PTC-Starter

- (1) Be careful not to allow over-voltage and over-current.
- (2) Do not drop or handle carelessly.
- (3) Keep away from any liquid.
If liquid such as oil or water enters the PTC, PTC materials may fail due to breakdown of their insulating capabilities.
- (4) If the exterior of the PTC is damaged, the resistance value may be altered. This can cause damage to the compressor and result in a no-start or hard-to-start condition.
- (5) Always use the PTC designed for the compressor and make sure it is properly attached to the compressor. Parts may appear physically identical but could have different electrical ratings. Replace parts by part number and model number. Use only approved substitute parts.

4-3 OLP (OVERLOAD PROTECTOR)

4-5-1 Definition of OLP

- (1) OLP (OVERLOAD PROTECTOR) is attached to the Compressor and protects the Motor by opening the circuit to the Motor if the temperature rises and activating the bimetal spring in the OLP.
- (2) When high current flows to the Compressor motor, the Bimetal works by heating the heater inside the OLP, and the OLP protects the Motor by cutting off the current flowing to the Compressor Motor.

4-5-2 Role of the OLP

- (1) The OLP is attached to the Sealed Compressor used for the Refrigerator. It prevents the Motor Coil from being started in the Compressor.
- (2) For normal operation of the OLP, do not turn the Adjust Screw of the OLP in any way.

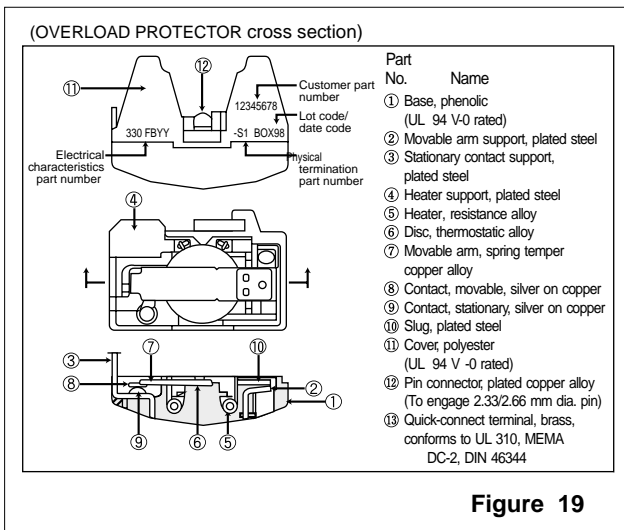

4-4 TO REMOVE THE COVER PTC

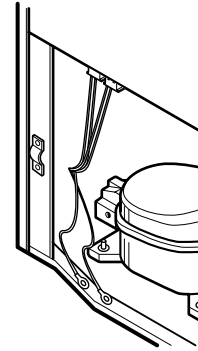

- (1) Remove the Cover Back M/C.
- (2) Disconnect two housing upper side of comp connected in.
- (3) Loosen two screws on comp base.

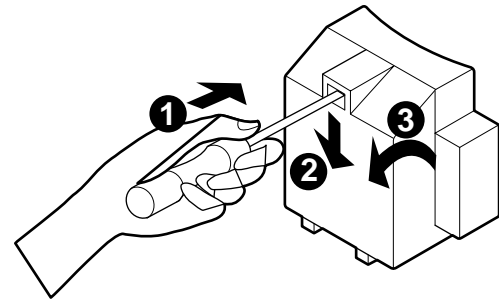

- (4) Use a L-shaped flap tool to pry off the cover.
- (5) Assembly in reverse order of disassembly.

5. CIRCUIT DIAGRAM

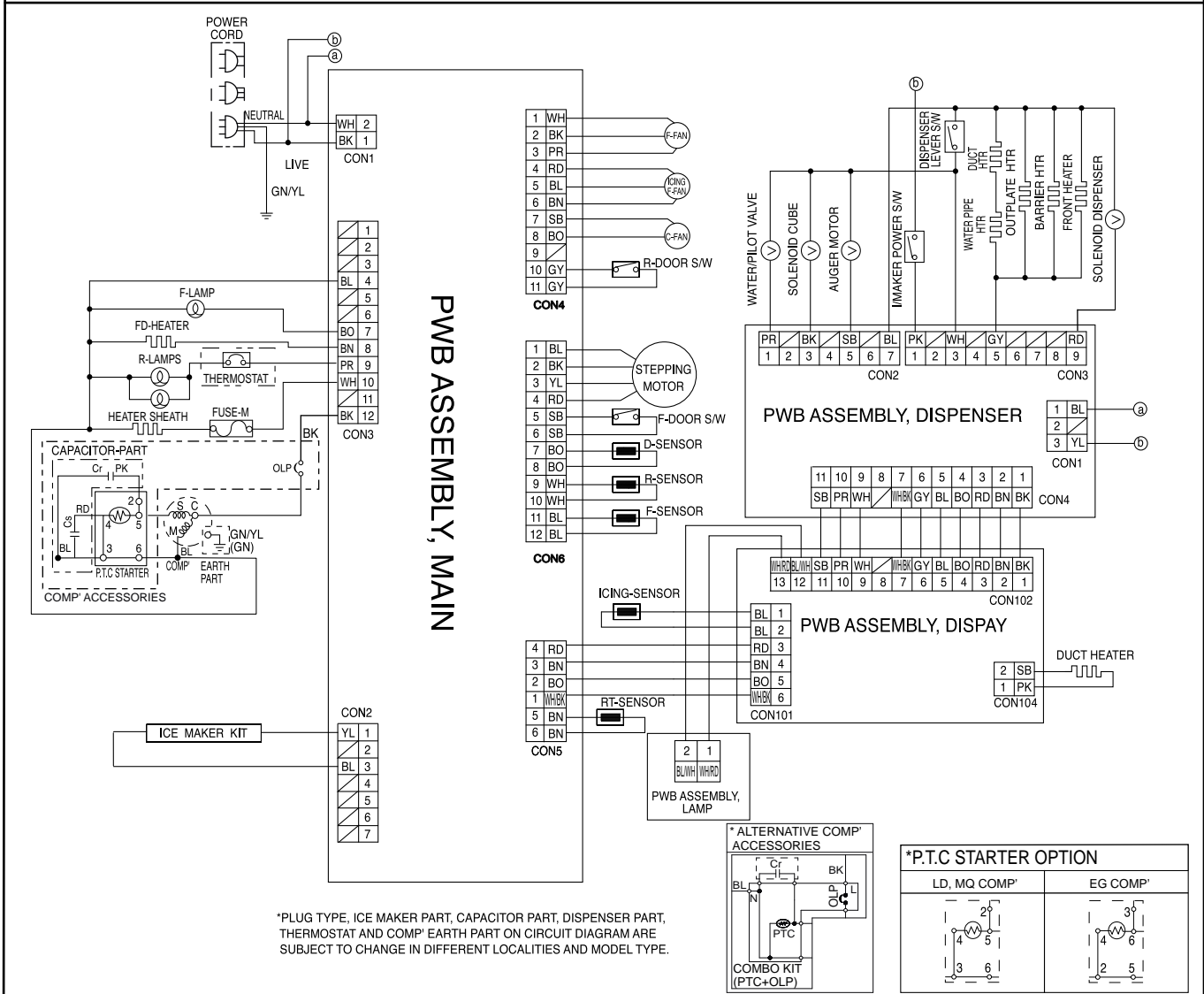

*PLUG TYPE, ICE MAKER PART, CAPACITOR PART, DISPENSER PART, THERMOSTAT AND COMP' EARTH PART ON CIRCUIT DIAGRAM ARE SUBJECT TO CHANGE IN DIFFERENT LOCALITIES AND MODEL TYPE.

- BK : BLACK
- YL : YELLOW
- SB : SKY BLUE
- BN : BROWN
- GN : GREEN
- PK : PINK
- BO : BRIGHT ORANGE
- PR : PURPLE
- GN/YN : GREEN/YELLOW
- GY : GRAY
- WH : WHITE
- BL/WH : BLUE/WHITE
- RD : RED
- WH/BK : WHITE/BLACK
- RD/WH : RED/WHITE

6. TROUBLESHOOTING

6-1 COMPRESSOR AND ELECTRIC COMPONENTS

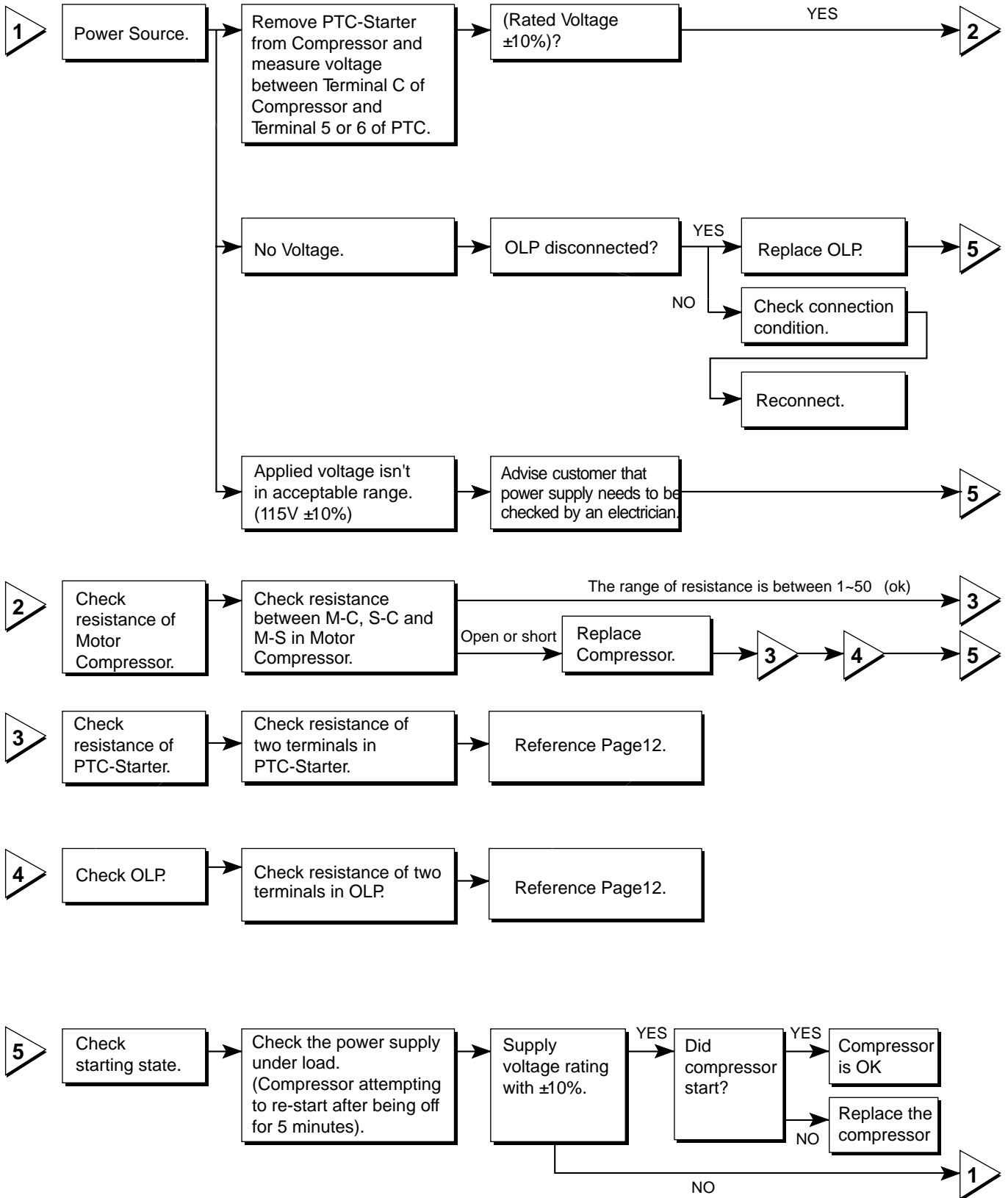

6-2 OTHER ELECTRICAL COMPONENTS

Not cooling at all

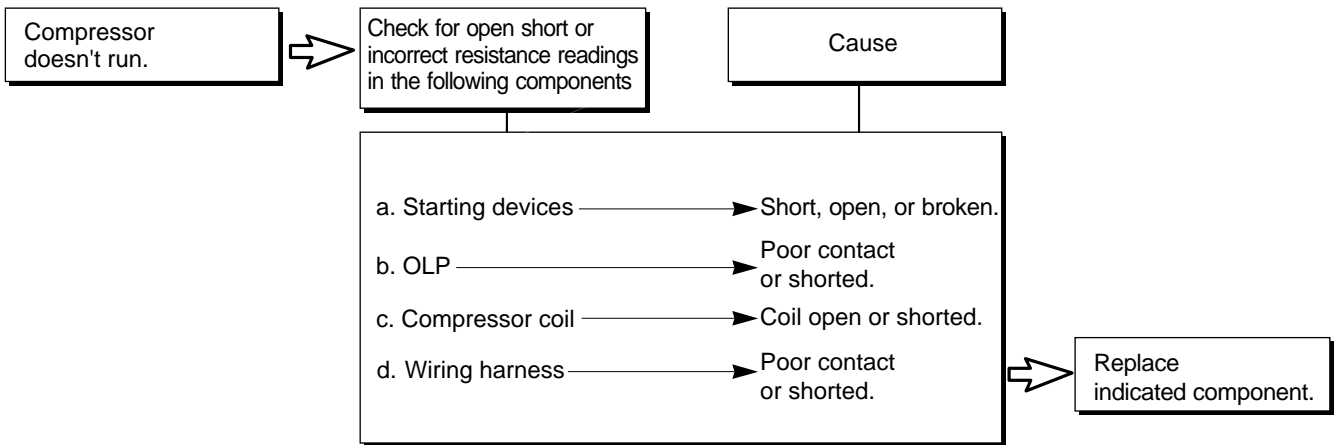

Poor cooling performance

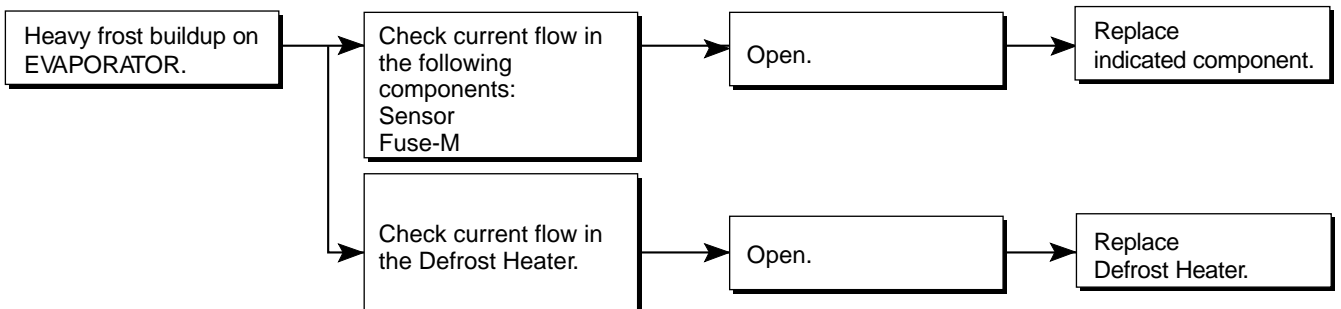
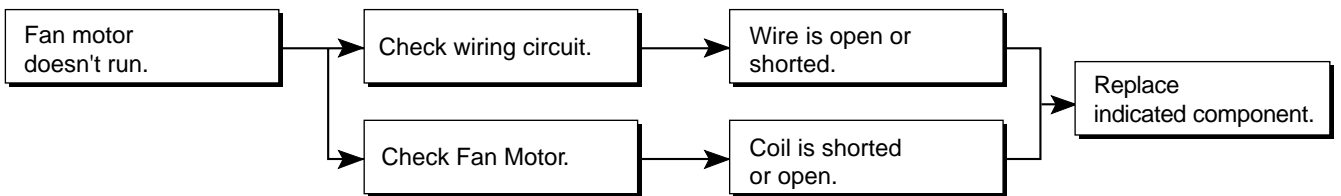
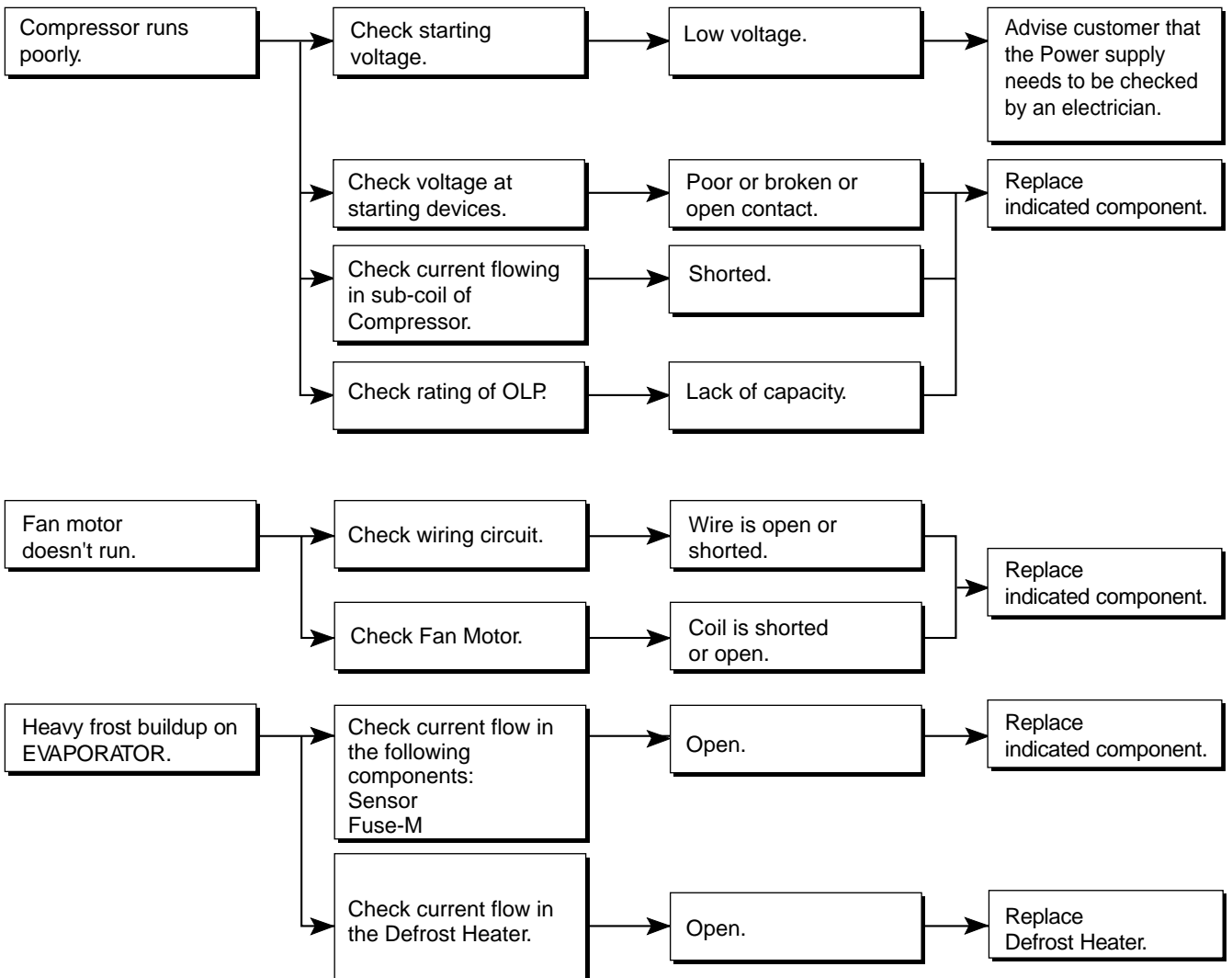

6-3 SERVICE DIAGNOSIS CHART

COMPLAINT	POINTS TO BE CHECKED	REMEDY
No Cooling.	<ul style="list-style-type: none"> • Is the power cord unplugged from the outlet? • Check if the power switch is set to OFF. • Check if the fuse of the power switch is shorted. • Measure the voltage of the power outlet. 	<ul style="list-style-type: none"> • Plug into the outlet. • Set the switch to ON. • Replace the fuse. • If the voltage is low, correct the wiring.
Cools poorly.	<ul style="list-style-type: none"> • Check if the unit is placed too close to the wall. • Check if the unit is placed too close to the stove, gas cooker, or in direct sunlight. • Is the ambient temperature too high or the room door closed? • Check if food put in the refrigerator is hot. • Did you open the door of the unit too often or check if the door is sealed properly? • Check if the Control is set to Warm position. 	<ul style="list-style-type: none"> • Place the unit about 4 inches (10 cm) from the wall. • Place the unit away from these heat sources. • Lower the ambient temperature. • Put in foods after they have cooled down. • Don't open the door too often and close it firmly. • Set the control to Recommended position.
Food in the Refrigerator is frozen.	<ul style="list-style-type: none"> • Is food placed in the cooling air outlet? • Check if the control is set to colder position. • Is the ambient temperature below 41°F(5°C)? 	<ul style="list-style-type: none"> • Place foods in the high-temperature section. (front part) • Set the control to Recommended position. • Set the control to Warm position.
Condensation or ice forms inside the unit.	<ul style="list-style-type: none"> • Is liquid food sealed? • Check if food put in the refrigerator is hot. • Did you open the door of the unit too often or check if the door is sealed properly? 	<ul style="list-style-type: none"> • Seal liquid foods with wrap. • Put in foods after they have cooled down. • Don't open the door too often and close it firmly.
Condensation forms in the Exterior Case.	<ul style="list-style-type: none"> • Check if the ambient temperature and humidity of the surrounding air are high. • Is there a gap in the door gasket? 	<ul style="list-style-type: none"> • Wipe moisture with a dry cloth. It will disappear in low temperature and humidity. • Fill up the gap.
There is abnormal noise.	<ul style="list-style-type: none"> • Is the unit positioned in a firm and even place? • Are any unnecessary objects placed in the back side of the unit? • Check if the Drip Tray is not firmly fixed. • Check if the cover of the compressor enclosure in the lower front side is taken out. 	<ul style="list-style-type: none"> • Adjust the Leveling Screw, and position the refrigerator in a firm place. • Remove the objects. • Fix the Drip Tray firmly in the original position. • Place the cover in its original position.
Door does not close well.	<ul style="list-style-type: none"> • Check if the door gasket is dirty with an item like juice. • Is the refrigerator level? • Is there too much food in the refrigerator? 	<ul style="list-style-type: none"> • Clean the door gasket. • Position in a firm place and level the Leveling Screw. • Make sure food stored in shelves does not prevent the door from closing.
Ice and foods smell unpleasant.	<ul style="list-style-type: none"> • Check if the inside of the unit is dirty. • Are foods with a strong odor unwrapped? • The unit smells of plastic. 	<ul style="list-style-type: none"> • Clean the inside of the unit. • Wrap foods that have a strong odor. • New products smell of plastic, but this will go away after 1-2 weeks.

Other possible problems:

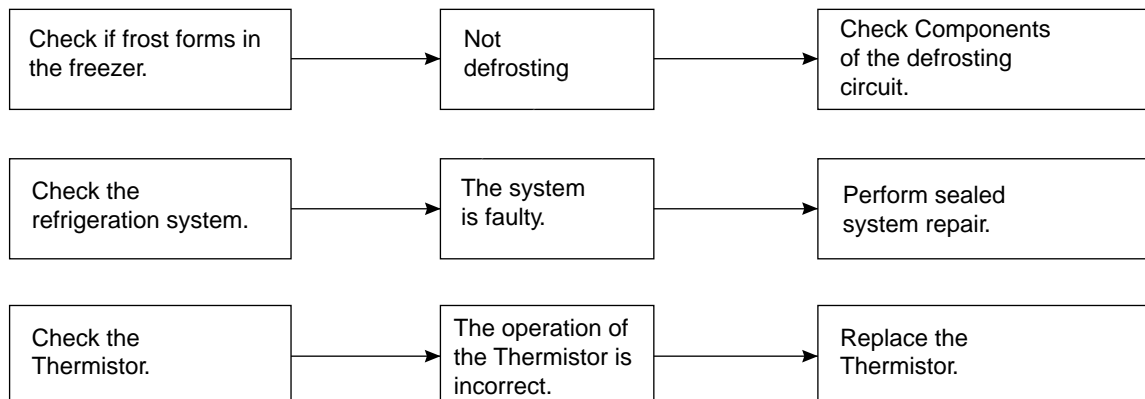

6-4 REFRIGERATION CYCLE

Troubleshooting Chart

CAUSE		STATE OF THE UNIT	STATE OF THE EVAPORATOR	TEMPERATURE OF THE COMPRESSOR	REMARKS
LEAKAGE	PARTIAL LEAKAGE	Freezer compartment and Refrigerator don't cool normally.	Low flowing sound of Refrigerant is heard and frost forms in inlet only.	A little higher than ambient temperature.	<ul style="list-style-type: none"> Refrigerant level is low due to a leak. Normal cooling is possible by restoring the normal amount of refrigerant and repairing the leak.
	COMPLETE LEAKAGE	Freezer compartment and Refrigerator don't cool normally.	Flowing sound of refrigerant is not heard and frost isn't formed.	Equal to ambient temperature.	<ul style="list-style-type: none"> No discharging of Refrigerant. Normal cooling is possible by restoring the normal amount of refrigerant and repairing the leak.
CLOGGED BY DUST	PARTIAL CLOG	Freezer compartment and Refrigerator don't cool normally.	Flowing sound of refrigerant is heard and frost forms in inlet only.	A little higher than ambient temperature.	<ul style="list-style-type: none"> Normal discharging of the refrigerant. The capillary tube is faulty.
	WHOLE CLOG	Freezer compartment and Refrigerator don't cool.	Flowing sound of refrigerant is not heard and frost isn't formed.	Equal to ambient temperature.	<ul style="list-style-type: none"> Normal discharging of the Refrigerant.
MOISTURE CLOG		Cooling operation stops periodically.	Flowing sound of refrigerant is not heard and frost melts.	Lower than ambient temperature.	<ul style="list-style-type: none"> Cooling operation restarts when heating the inlet of the capillary tube.
DEFECTIVE COMPRESSION	COMP-RESSION	Freezer and Refrigerator don't cool.	Low flowing sound of refrigerant is heard and frost forms in inlet only.	A little higher than ambient temperature.	<ul style="list-style-type: none"> Low pressure at high side of compressor due to low refrigerant level.
	NO COMP-RESSION	No compressing operation.	Flowing sound of refrigerant is not heard and there is no frost.	Equal to ambient temperature.	<ul style="list-style-type: none"> No pressure in the high pressure part of the compressor.

6-4-1 SEALED SYSTEM DIAGNOSIS

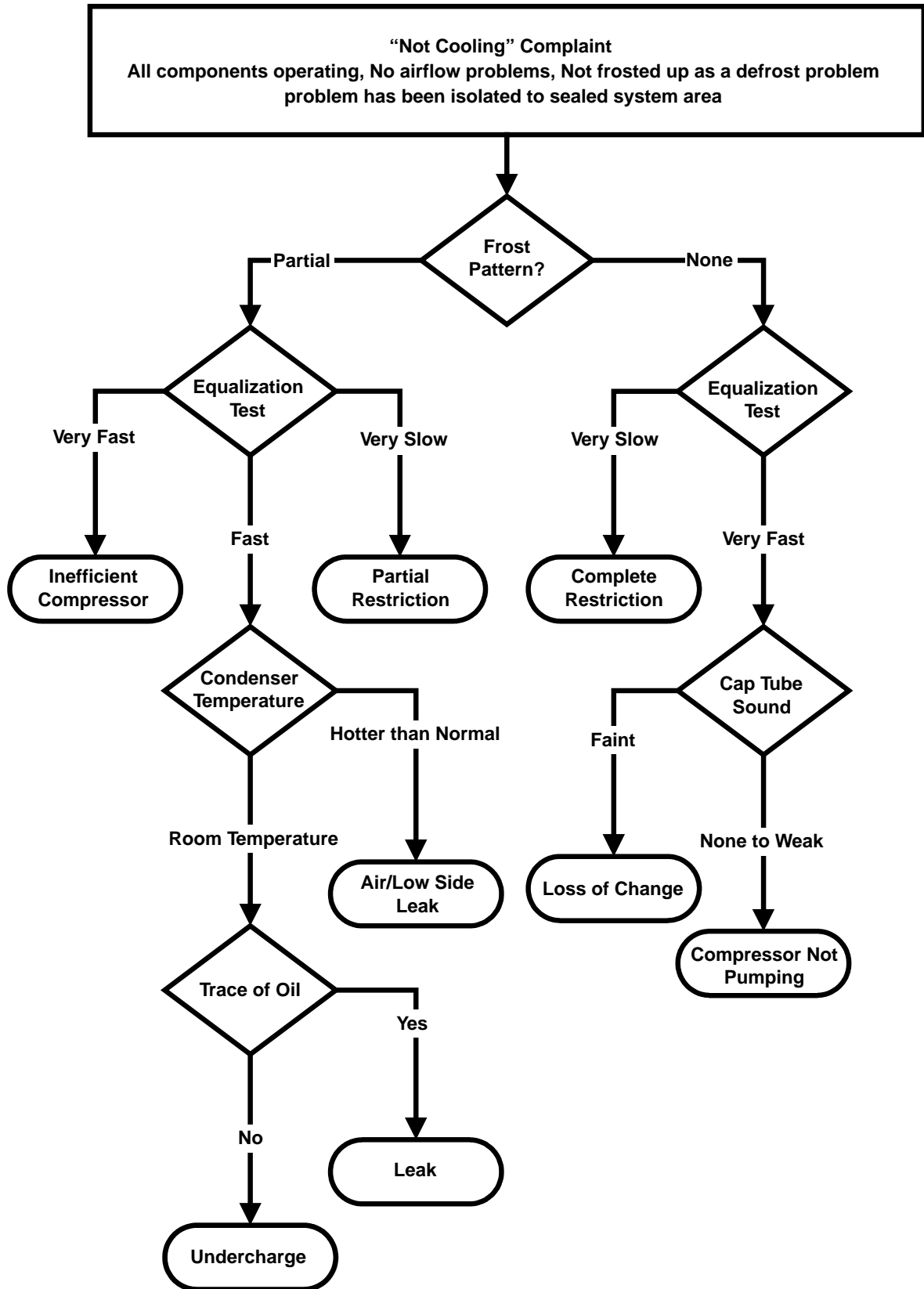

(The equalization test is trying to restart a compressor using a start kit after it has been operating.)

7. OPERATION PRINCIPLE AND REPAIR METHOD OF ICEMAKER

7-1 OPERATION PRINCIPLE

7-1-1 Operation Principle of IceMaker

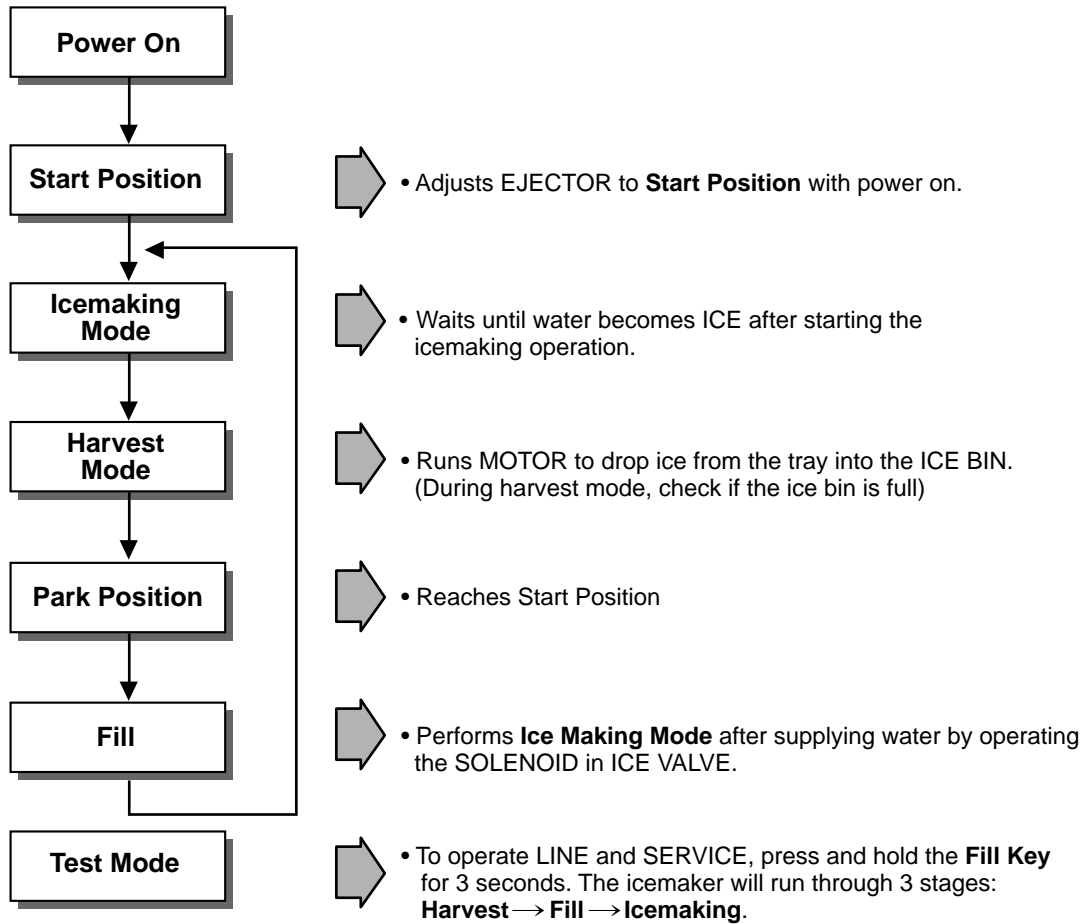

1. Turning the Icemaker stop switch off (O) stops the ice making function.
2. Setting the Icemaker switch to OFF and then turning it back on will reset the icemaker control.

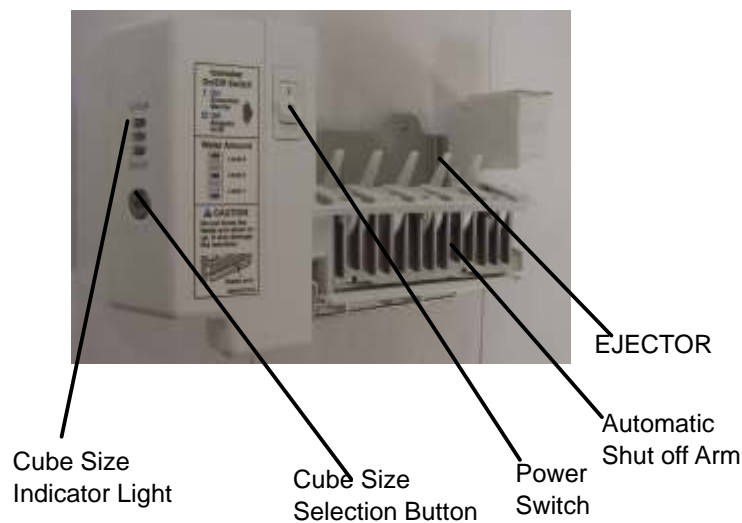

7-2 ICE MAKER FUNCTIONS

7-2-1. Icemaking Mode

1. Icemaking refers to the freezing of supplied water in the ice tray. Complete freezing is assured by measuring the temperature of the Tray with Icemaking SENSOR.
2. Icemaking starts after completion of the water fill operation.
3. The Ice Making function is completed when the sensor reaches 19°F (-7°C), 55 minutes after starting.

NOTE : After Icemaker Power is ON, the Icemaker heater will be on for test for 6 sec.



7-2-2. Harvest Mode

1. Harvest (Ice removing) refers to the operation of dropping ices into the ice bin from the tray when icemaking has completed.
 2. Harvest mode:
 - (1) The Heater is ON for 30 seconds, then the motor starts.
 - (2) The feeler arm senses the quantity of ice in the ice storage bin while rotating with the EJECTOR.
 - A. Ice storage bin is full : The EJECTOR stops (heater off).
 - B. Ice storage bin is not full : The EJECTOR rotates twice to open for ice.
- * If the EJECTOR does not rotate once within 5 minutes in B mode, separate heater control mode starts operating to prevent the EJECTOR from being constrained. (It is recommended that the user open for ice to return to normal mode.)

7-2-3. Fill/Park Position

1. Once a normal harvest mode has been completed, the water solenoid will be activated.
2. The amount of water is adjusted by pressing the Fill Key repeatedly. This changes the time allowed for fill as illustrated in the table below.





Water supply amount TABLE

STAGE	TIME TO SUPPLY	INDICATIONS	REMARKS
1	5 sec.		The water amount will vary depending on the water control Switch setting, as well as the water pressure of the connected water line.
2	5.5 sec. (FIRST STAGE)		
3	6 sec.		

7-2-5 Function TEST

1. This is a forced operation for TEST, Service, cleaning, etc. It is operated by pressing and holding the Fill Key for 3 seconds.
2. The test works only in the Icemaking Mode. It cannot be entered from the Harvest or Fill mode.
3. **Caution!** If the test is performed before water in the icemaker is frozen, the ejector will pass through the water. When the Fill mode begins (Stage 4), unless the water supply has been shut off, added water will overflow into the ice bin. If the control doesn't operate normally in the TEST mode, check and repair as needed.
4. After water is supplied, the normal CYCLE is followed: **icemaking Harvest Park Position Fill.**
5. Five seconds after Stage 5 is completed, the Ice Maker returns to MICOM control. The time needed to supply water resets to the pre- test setting.

Diagnosis TABLE

STAGE	ITEMS	INDICATOR	REMARKS
1	HEATER		Five seconds after heater starts, a heater will go off if the temperature by sensor is higher than 10°C
2	MOTOR		Five seconds after heater starts, you can confirm that a motor is moving.
3	HALL IC I		Check if Ice Bin is full or not. If Ice bin is full, the motor and heater are off and on stand by until Ice bin is empty.
4	HALL IC II		You can confirm HALL IC detection of start position.
5	VALVE		Two seconds after detection of start position, you can confirm that valve is on.
6	Reset	Return to Status prior to TEST MODE	Five seconds after fifth stage is completed, The icemaker resets to initial status.

7-3 DEFECT DIAGNOSIS FUNCTION

7-3-1 ERROR CODES shown on Ice Maker water supply control panel

NO	DIVISION	INDICATOR	CONTENTS	REMARKS
1	Normal	Mark time to supply	None	Display switch operates properly
2	Icemaking Sensor malfunction		Open or short-circuited wire	Make sure that the wire on each sensor is connected.

8. DESCRIPTION OF FUNCTION & CIRCUIT OF MICOM

8-1 FUNCTION

8-1-1 Function

- When the appliance is plugged in, it is set to 37°F for Refrigerator and 0°F for freezer.
You can adjust the Refrigerator and the Freezer control temperature by pressing the ADJUST button.
- When the power is initially applied or restored after a power failure, it is set to Control temperature Previously.



8-1-2 How to Toggle the Display between °F & °C

- The initial setting is °F and the display temperature mode can be changed from °F to °C or °C to °F by pressing and holding the FRZ TEMP and the REF TEMP keys at the same time for over 5 seconds.

8-1-3 Lock function (dispenser and display button lock)

- When the refrigerator is first turned on, the buttons are not locked. The lock indicator light is turn OFF
- To lock the display, the dispenser, and the control panel, press and hold the LOCK button for 3 seconds. The lock indicator Light is turn ON
- The LOCK button is the only control feature that remains active in the locked state. The buzzer sound, other control buttons, and the dispenser are deactivated.
- To release from the locked state, press and hold the LOCK button again for 3 seconds.

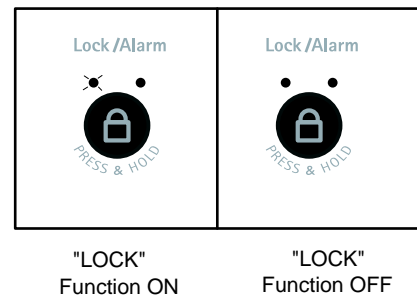

8-1-4 Filter condition display function

- There is a replacement indicator light for the filter cartridge on the dispenser.
- Water filter needs replacement once six months or of using water filter.
- Water Filter icon turn on to tell you need to replace the filter soon.
- After replacing the filter, press and hold the lock button more than 3 seconds.
Water Filter icon turn off with reset status.

Classification	In initial Power On / Filter RESET	Replace indicator light on
Filter Status Display		

8-1-5 Ultra Ice selection

Please select this function for quick freezing.

- Function is repeat Ultra Ice Icon whenever pressing Ultra Ice button.
- Ultra Ice function automatically turns off after a fixed time passes.



"Ultra Ice"
Function ON

"Ultra Ice"
Function OFF

8-1-6 Dispenser use selection

You can select water or ice.

Select water, crushed ice, or ice cubes by cycling through the selections when pressing the DISPENSER button,

Hold your cup in the dispenser for a few seconds after dispensing ice or water to allow the last pieces of ice or drops of water to fall into the cup.

When after initially establishing the water comes out, the water tank inside fills and until at the time of quality the hour is caught.

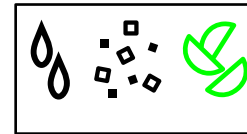
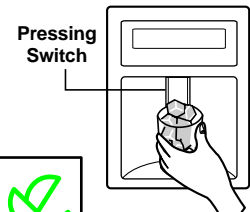
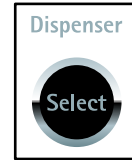

8-1-7 DISPENSER LIGHT

Please select this function for DISPENSER LIGHT MODE.

1. Normal status (LIGHT icon is OFF): When dispenser is operated, DISPENSER LIGHT is ON.
2. ON status (LIGHT icon is ON): DISPENSER LIGHT is on continuously

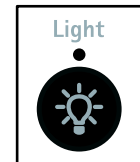

8-1-8 CONTROL OF FREEZER FAN MOTOR

1. Freezer fan motor has high and standard speeds.
2. High speed is used at power-up, for Ultra Ice, and when refrigerator is overloaded.
Standard speeds is used for general purposes.
3. To improve cooling speed, the RPM of the freezer fan motor change from normal speed to high.
4. High speed (2700RPM) : Initial power on or load corresponding operation, Ultra Ice.
Normal speed (2400RPM) : Door open conditions.
5. Fan motor stops when refrigerator open.

8-1-9 Cooling Fan Motor

1. The cooling fan is switched ON and OFF in conjunction with the compressor.
2. The cooling fan runs at a single speed.

8-1-10 Ice Compartment Fan

The Icing Fan is controlled by the the sensor on the top of the ice compartment.

The Failure sensing method is the same as in the fan motor of the freezer
(refer to failure diagnosis function table for failure display)

8-1-11 Ultra Ice

1. The purpose of this function is to intensify the cooling speed of freezer and to increase the amount of ice.
2. Whenever selection switch is pressed, selection/release, the LED will turn ON or OFF.
3. If there is a power outage and the refrigerator is powered on again, Ultra Ice will be canceled.
4. To activate this function, press the Ultra Ice key and the LED will turn ON. This function will remain activated for 24 hrs. The first three hours the compressor and Freezer Fan will be ON. The next 21 hours the freezer will be controlled at the lowest temperature. After 24 hours or if the Ultra Ice key is pressed again, the freezer will return to its previous temperature.
5. During the first 3 hours:
 - (1) Compressor and freezer fan (HIGH RPM) run continuously.
 - (2) If a defrost cycle begins during the first 90 minutes of Ultra Ice, the Ultra Ice cycle will complete its cycle after defrosting has ended.
If the defrost cycle begins when Ultra Ice has run for more than 90 minutes, Ultra Ice will run for two hours after the defrost is completed.
 - (3) If Ultra Ice is pressed during defrost, Ultra Ice LED is on but this function will start seven minutes after defrost is completed and it shall operate for three hours.
 - (4) If Ultra Ice is selected within seven minutes after compressor has stopped, the compressor (compressor delays seven minutes) shall start after the balance of the delay time.
 - (5) The fan motor in the freezer compartment runs at high speed during Ultra Ice.
6. For the rest of the 21 hours, the freezer will be controlled at the lowest temperature.

8-1-12 FREEZER & REFRIGERATOR LAMP AUTO OFF

1. To avoid heat damage caused by the lamp, it is turned off automatically when the refrigerator door is open for more than 7 minutes, also has a thermoprotector as a double protection.

8-1-13 Alarm for Open Door

1. This feature sounds a buzzer when the freezer or refrigerator door is not closed within 1 minute after it is opened.
2. One minute after the door is opened, the buzzer sounds three times each for 1/2 seconds. These tones repeat every 30 seconds.
3. The alarm is cancelled when the freezer or the refrigerator is closed while the buzzer sounds.

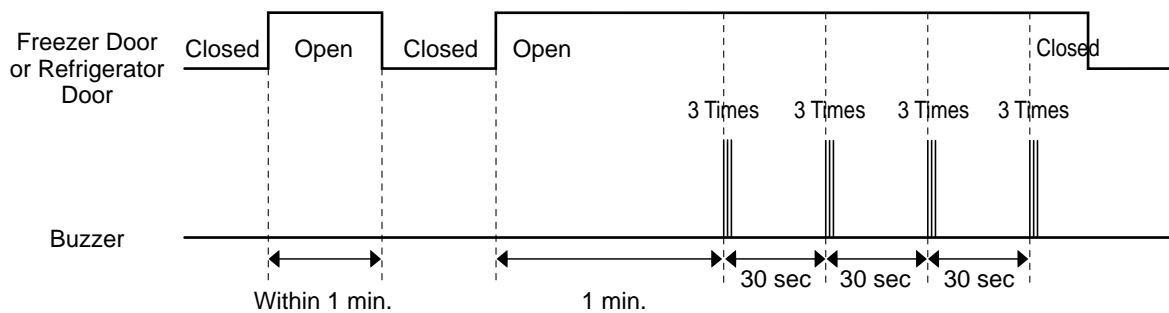

8-1-14 Defrosting (removing frost)

1. Defrosting starts each time the accumulated COMPRESSOR running time is between 7:30 and 50 hours. This time is determined by how often and how long the doors are opened.
2. For initial power on or for restoring power, defrosting starts when the compressor running time reaches 4 hours.
3. Defrosting stops if the sensor temperature reaches 46.4°F(8°C) or more. If the sensor doesn't reach 46.4°F(8°C) in 1 hours, the defrost mode is malfunctioning. (Refer to the defect diagnosis function, 8-1-15.)
4. Defrosting won't function if its sensor is defective (wires are cut or short circuited)

8-1-15 Defect Diagnosis Function

1. Automatic diagnosis makes servicing the refrigerator easy.
2. When a defect occurs, the buttons will not operate; but the tones, such as ding, will sound.
3. When defect is repaired the defect code is removed and refrigerator returns to normal operation (RESET).
4. The Defect code is shown on the Display.



LED check function: If simultaneously pressing Ultra Ice button and Frz Temp for a second, display LED graphics on. If releasing the button, the LED graphic displays the previous status.

8-1-16 Display OFF Mode:

To activate this mode press and hold ULTRA ICE and FRZ TEMP key over 5 seconds until the lights turn off. If the Display is touched or any door opens the lights will turn on and after 20 seconds of inactivity the lights will turn off automatically.

To exit Display OFF Mode press and hold ULTRA ICE and FRZ TEMP key over 5 seconds until the lights tilt.

Display OFF Mode does not affect the temperature control settings of the unit.

Note: This Function is activate by default.

ERROR CODE on display panel

No.	ITEM	ERROR CODE		CONTENTS	REMARKS
		FRZ TEMP	REF TEMP		
1	Failure of Freezer sensor	Er	FS	Cut or short circuit wire.	Inspect Connecting wires on each sensor
2	Failure of Refrigerator sensor	Er	rS	Cut or short circuit wire.	
3	Failure of defrost sensor	Er	dS	Cut or short circuit wire.	
4	Failure of Room Temperature sensor	When display check mode: Er rt		Cut or short circuit wire.	
5	Failure of Icing sensor	Er	IS	Cut or short circuit wire.	
6	Failure of defrost mode	Er	dH	When defrost sensor doesn't reach 46°F(8°C) within 1 hour after starting defrost	Snapping of defrost heater or Temperature fuse, pull-out of connector (indicated minimum 1 hour after failure occurs)
7	Failure of BLDC Fan Motor at Freezing Compartment	Er	FF	If there is no fan motor signal for more than 115sec in operation fan motor	Poor motor, hooking to wires of fan, contact of structures to fan, snapping or short circuit of Lead wires
8	Failure of BLDC Fan Motor for Ice Maker at Freezing compartment	Er	IF	If there is no fan motor signal for more than 114sec in operation fan motor	Poor motor, hooking to wires of fan, contact of structures to fan, snapping or short circuit of Lead wires
9	Failure of Communication between display and Main PCB	Er	CO	If there is no communication between display and main PCB	check the wires of display connection

LED check function: If simultaneously pressing Ultra Ice button and Frz Temp for a second, display LED graphics on. If releasing the button, the LED graphic displays the previous status.

8-1-17 TEST Mode

1. The Test mode allows checking the PCB and the function of the product as well as finding out the defective part in case of an error.
2. The test mode is operated by pressing two buttons at Display panel.
3. While in the test mode, the function control button is not recognized, but the recognition tone sounds.
4. After exiting the test mode, be sure to reset by unplugging and then plugging in the appliance.
5. If an error, such as a sensor failure, is detected while in the test mode, the test mode is cleared and the error code is displayed.
6. While an error code is displayed, the test mode will not be activated.

Table 1. Function Test

MODE	OPERATION	FUNCTION	REMARKS
TEST1	Push Test Switch (in the main Board) once.	<ol style="list-style-type: none"> 1) Continuous operation of the COMPRESSOR and the Freezer fan 2) Stepping DAMPER OPEN 3) Defrosting HEATER OFF 4) DISPLAY LED all ON 	Maximum test time: 5 minutes
TEST2	Push TEST Switch once in TEST MODE1.	<ol style="list-style-type: none"> 1) Continuous operation of the COMPRESSOR and the Freezer fan 2) Stepping DAMPER CLOSE 3) Defrosting HEATER OFF 4) DISPLAY LED shows no. 2 	Maximum test time: 5 minutes
TEST3	Push TEST Switch once in TEST MODE 2.	<ol style="list-style-type: none"> 1) COMPRESSOR and the Freezer fan OFF 2) Stepping DAMPER CLOSE 3) Defrosting HEATER ON 4) DISPLAY LED shows no. 3 	Reset if the Temperature of the Defrosting Sensor is 46°F(8°C)or more. Maximum test time: 1 hour
RESET	Push TEST Switch once in TEST MODE3.	Reset to the previously setting Before TEST MODE.	The compressor will Start after a 7-minute Delay.

8-2-2 Load / Fan & Open Door Detection Circuit

1. Load Drive Condition Check

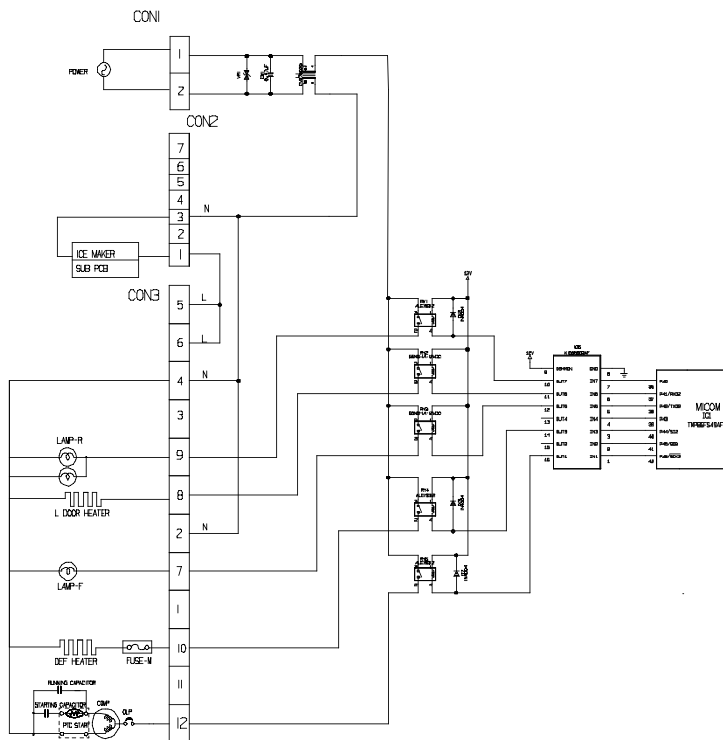

To measure outputs of the control board, check voltages between the pins for the following components:



CONNECTOR 2							
PIN	7	6	5	4	3	2	1
	N/C	N/C	N/C	N/C	N	N/C	ICE MKR

CONNECTOR 3						
PIN	12	11	10	9	8	7
	6	5	4	3	2	1
REG	---	---	DEF HEATER	LAMP-R	FD-RTR	LAMP-F
COM	---	---	N	---	---	---

*LOAD DRIVE AREA ON MAIN PCB

Circuit	Pin Number	Pin Number	Output Voltage
Lamp-R	Con3 Pin9	Con3 Pin4	115 VAC
Lamp-F	Con3 Pin7	Con3 Pin4	115 VAC
Defrost Heater	Con3 Pin10	Con3 Pin4	115 VAC
Compressor	Con3 Pin12	Con3 Pin4	115 VAC
L-Door Heater	Con3 Pin8	Con3 Pin4	115 VAC
Ice Maker	Con2 Pin1	Con3 Pin4	115 VAC

To measure output of the fans on the control board check voltages between the pins for the following components:

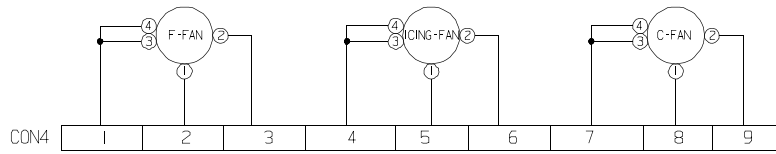

FAN	PIN NUMBER	PIN NUMBER	OUTPUT VOLTAGE	
			MOTOR ON	MOTOR OFF
Freezing compartment fan	Con4 Pin1	Con4 Pin2	13 VDC - 15 VDC	2 VDC or less
Machine compartment fan	Con4 Pin7	Con4 Pin8	13 VDC - 15 VDC	2 VDC or less
Icing compartment fan	Con4 Pin4	Con4 Pin5	13 VDC - 15 VDC	2 VDC or less



CONNECTOR 4											
PIN	1	2	3	4	5	6	7	8	9	10	11
	F-FAN			ICING-FAN			C-FAN			R-DOOR S/W	
	V	G	F	V	G	F	V	G	F		

3. Open Door Detection Circuit Check

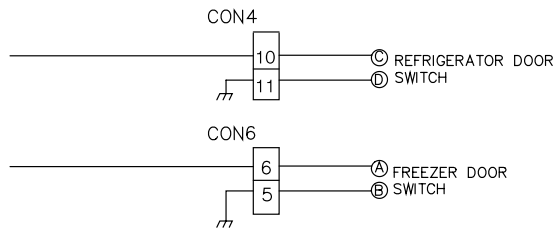

Measurement Location	Pin 10 & 11 of con4 Ref.Door Pin 5 & 6 of con6 Fre.Door
Closed	5 V
Open	0 V



CONNECTOR 4											
PIN	1	2	3	4	5	6	7	8	9	10	11
	F-FAN	ICING-FAN	C-FAN							R-DOOR SW	
	V	G	F	V	G	F	V	G	F		



CONNECTOR 6												
PIN	1	2	3	4	5	6	7	8	9	10	11	12
	STEPPING MOTOR			F-DOOR S/W		D-SNR		R-SNR		F-SNR		

8-2-3 Temperature Sensor Circuit

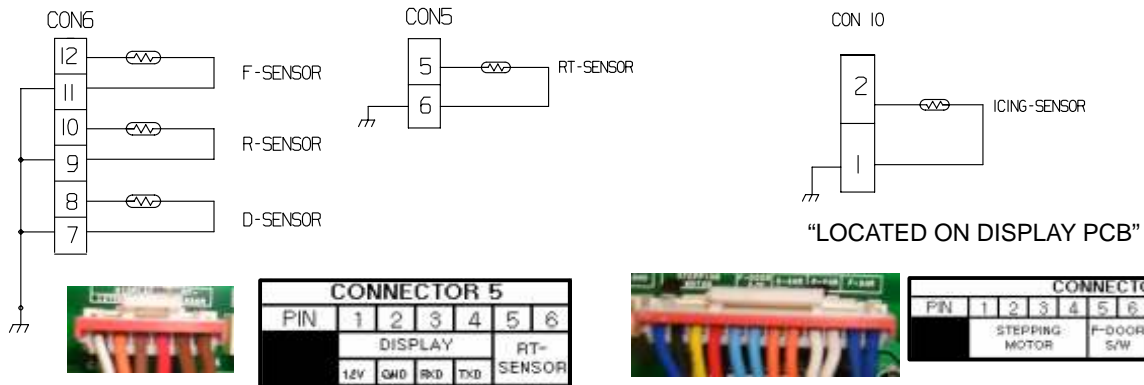

CONNECTOR 5						
PIN	1	2	3	4	5	6
	DISPLAY			RT-SENSOR		
	1.2V	CHD	RKD	TKD		



CONNECTOR 6												
PIN	1	2	3	4	5	6	7	8	9	10	11	12
	STEPPING MOTOR			F-DOOR S/W		D-SNR		R-SNR		F-SNR		

TEMPERATURE	RESISTANCE OF FREEZER/Icing SENSOR	RESISTANCE OF REFRIGERATOR & DEFROST SENSOR & ROOM SENSOR
- 20 °C (-4 °F)	22.3 K?	77 K?
- 15 °C (5°F)	16.9 K?	60 K?
- 10 °C (14 °F)	13.0 K?	47.3 K?
- 5 °C (23 °F)	10.1 K?	38.4 K?
0 °C (32 °F)	7.8 K?	30 K?
+ 5 °C (41 °F)	6.2 K?	24.1 K?
+ 10 °C (50 °F)	4.9 K?	19.5 K?
+ 15 °C (59 °F)	3.9 K?	15.9 K?
+ 20 °C (68 °F)	3.1 K?	13 K?
+ 25 °C (77 °F)	2.5 K?	11 K?
+ 30 °C (86 °F)	2.0 K?	8.9 K?
+ 40 °C (104 °F)	1.4 K?	6.2 K?
+ 50 °C (122 °F)	0.8 K?	4.3 K?

- The resistance of the SENSOR has a ±5% common difference.
- Measure the resistance of the SENSOR after leaving it for over 3 minutes in the measuring temperature. This delay is necessary due to sensor response speed.

8-2-4 Refrigeration Compartment Stepping Motor Damper Circuit

A reversible DC motor is used to open and close the damper.

To open the damper, push test button once.

To close the damper, push test button twice.

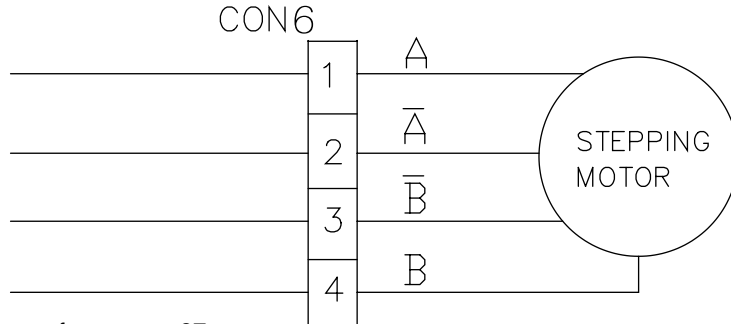

To see connector 6 picture, refer to page 37

8-2-5 Dispenser Drive Circuit

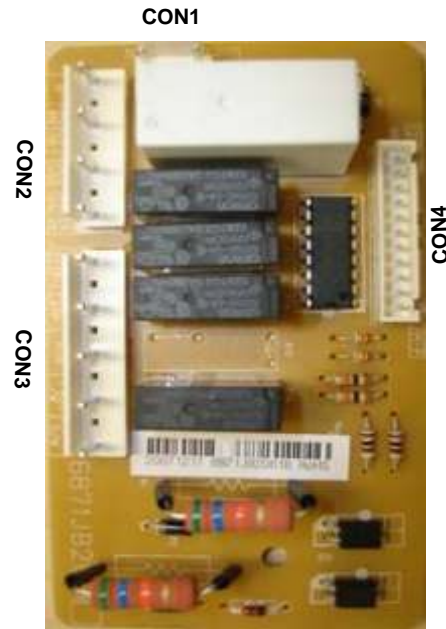
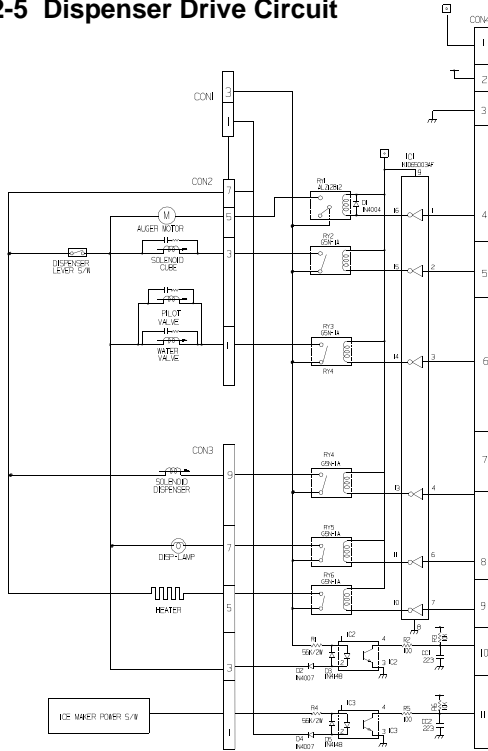

Circuit	Pin Number	Pin Number	Output Voltage
Auger Motor	Con2 Pin5	Con2 Pin7	115 VAC
Solenoid Cube	Con2 Pin3	Con2 Pin7	115 VAC
Pilot/ Water Valve	Con2 Pin1	Con2 Pin7	115 VAC
Solenoid Dispenser	Con3 Pin9	Con3 Pin3	115 VAC
Heater	Con3 Pin5	Con3 Pin3	115 VAC

To perform the measures CON1 **MUST BE** connected.



8-3 TROUBLESHOOTING

PROBLEM	INDICATED BY	CHECK	CHECKING METHOD	CAUSE	SOLUTION
POWER SOURCE is poor.	1. The whole	1. FREEZER/ REFRIGERATOR.	Check if FREEZER/REFRIGERATOR DOOR IS OPEN and check display.	POWER SOURCE is poor.	Replace Main PWB
		2. If LAMP is dim.	Check visually.	Applied voltage error.	Replace Main PWB
	2. DISPLAY LED	3. The connection of the MAIN PWB CONNECTOR.	Check connection of CONNECTOR.	CONNECTOR connection is poor.	Reconnect CONNECTOR
				TRANS FUSE is open.	Replace Main PWB
COOLING is poor.	NO COOLING.	1. If the COMPRESSOR operate.	USE TEST MODE1 (forced COOLING). If less than 7 minutes pass after compressor shuts off, don't press the KEY and wait.	COMPRESSOR locked or blocked.	Replace OLP, PTC.
				OLP, PTC is poor. COMPRESSOR RELAY is poor.	Replace MAIN PWB.
				THE CONNECTING WIRE is poor.	Check the connection of the black wire of the MAIN PWB CONNECTOR (CON3).
				2. If refrigerant is leaking.	Measure the amount of frost sticking on EVAPORATOR and the surface temperature of the condenser pipe.
	FREEZER TEMPERATURE is incorrect	1. If FAN MOTOR operates.	USE TEST MODE1 (forced COOLING).	FAN MOTOR is poor.	Replace the FAN MOTOR.
				CONNECTING WIRE is poor.	Certify the MOTOR and the connection of the wire of the MAIN PWB CONNECTOR (CON4).
		2. If DEFROSTING is normal.	Check the amount of frost sticking on the EVAPORATOR .	DEFROSTING is poor.	See DEFROSTING is poor.
		3. If SENSOR is normal.	of the Refrigerator SENSOR.	SENSOR RESISTANCE is poor.	Replace SENSOR.
		4. Door Line contact.	Check the seal when the door is closed.	Door liner damaged.	Replace door liner.

PROBLEM	INDICATED BY	CHECK	CHECKING METHOD	CAUSE	SOLUTION
COOLING is poor.	If REFRIGERATOR TEMPERATURE is too low.	1. If FREEZER TEMPERATURE is normal.	Check is FREEZER TEMPERATURE is too low.		Make sure the DOOR is attached.
		2. If amount of cool air from FAN MOTOR is sufficient.	Make sure that the amount and speed of cool air are sufficient by touching the check supplied on the REFRIGERATOR.	FAN MOTOR is poor.	Replace FAN MOTOR.
				Passage of cool air is blocked.	Remove impurities.
				EVA frozen.	See DEFROSTING is poor.
3. Door Line contact.	Check door seal when door is closed.	Door liner damaged.	Replace Door liner.		
DEFROSTING is poor.	NO DEFROSTING.	1. If HEATER emits heat.	USE TEST MODE3 (forced DEFROSTING).	HEATER disconnection.	Replace HEATER.
				TEMPERATURE FUSE disconnection.	Replace TEMPERATURE FUSE.
				Connection is poor.	Check EVAPORATOR connection and wire of MAIN PWB CONNECTOR.
				DEFROST-SENSOR is poor.	Replace DEFROST-SENSOR.
		2. If DRAIN PIPE is blocked.	Check DRAIN PIPE.	DRAIN PIPE is blocked.	Remove ice and impurities.
					Check HEATER PLATE resistance.
		3. If ice remains after DEFROSTING.	Make sure that DEFROST SENSOR is connected.	Connection is poor.	Reassemble the DEFROST-SENSOR.
					Make sure that FREEZER /REFRIGERATOR DOOR is closed.

8-4 MAIN PWB ASSEMBLY AND PARTS LIST

8-4-1 Main PWB Assembly

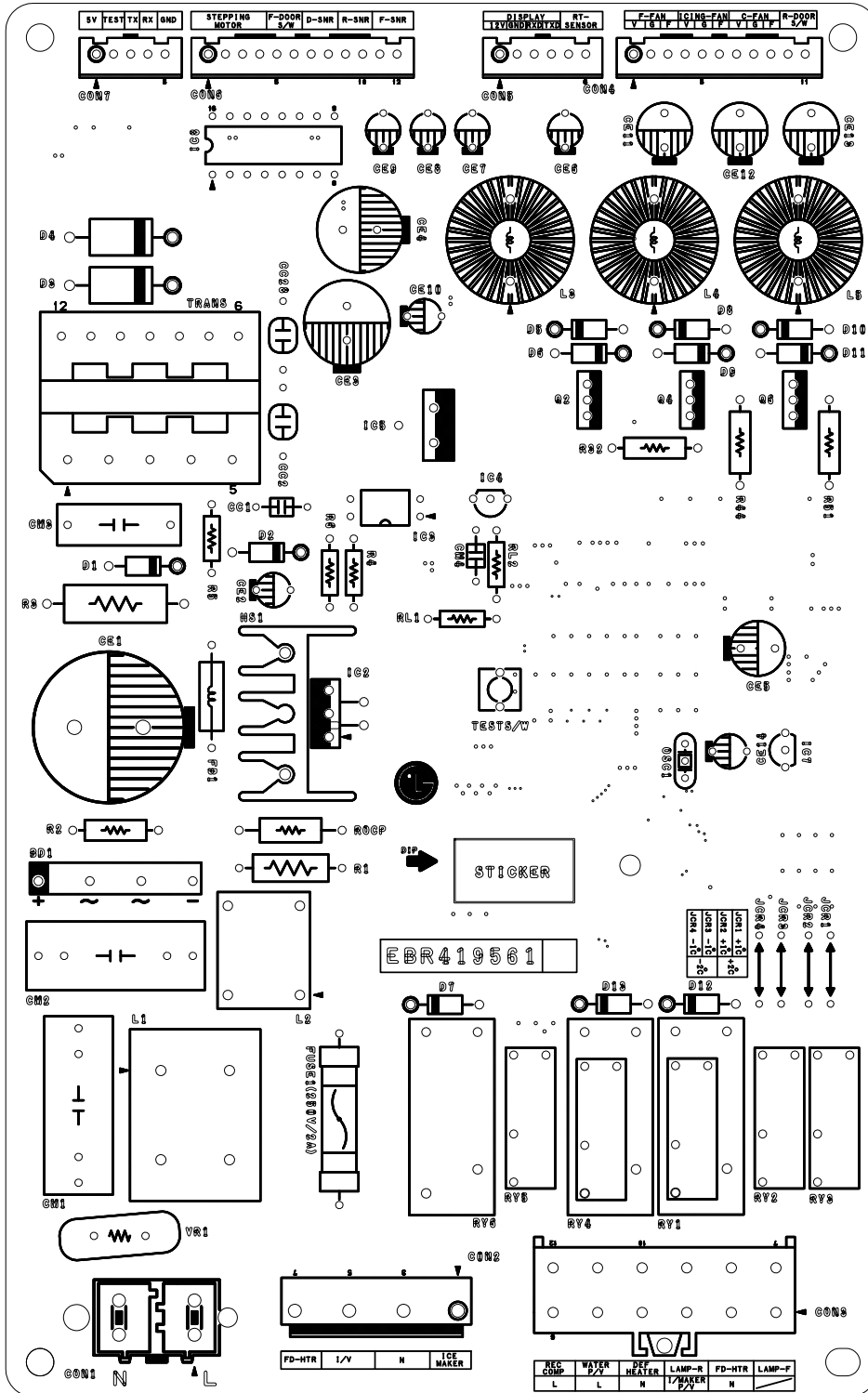

8-4-2 Dispenser Drive PWB Assembly

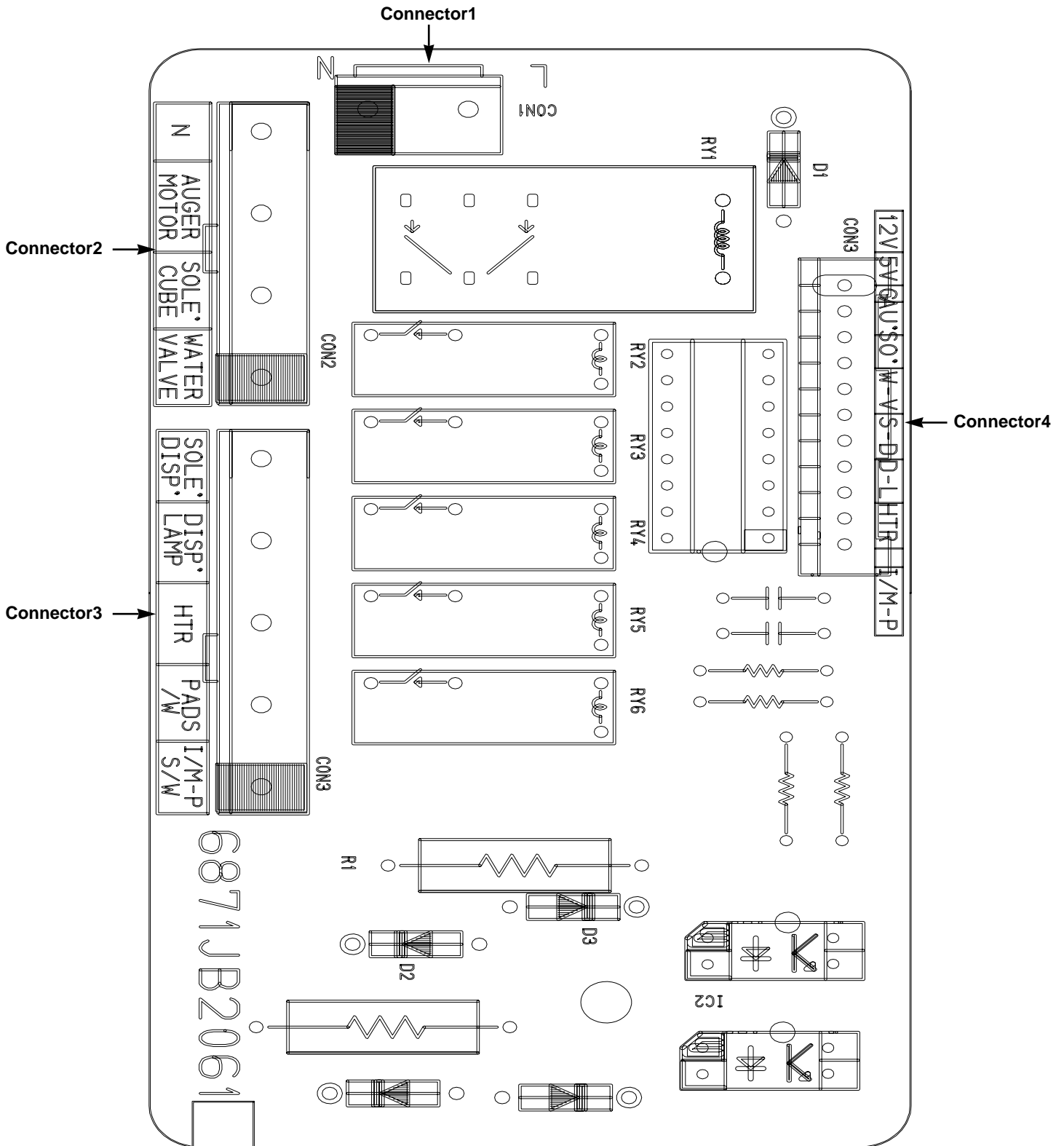

FREEZER PARTS

Caution: Use the part number to order part, not the position number.

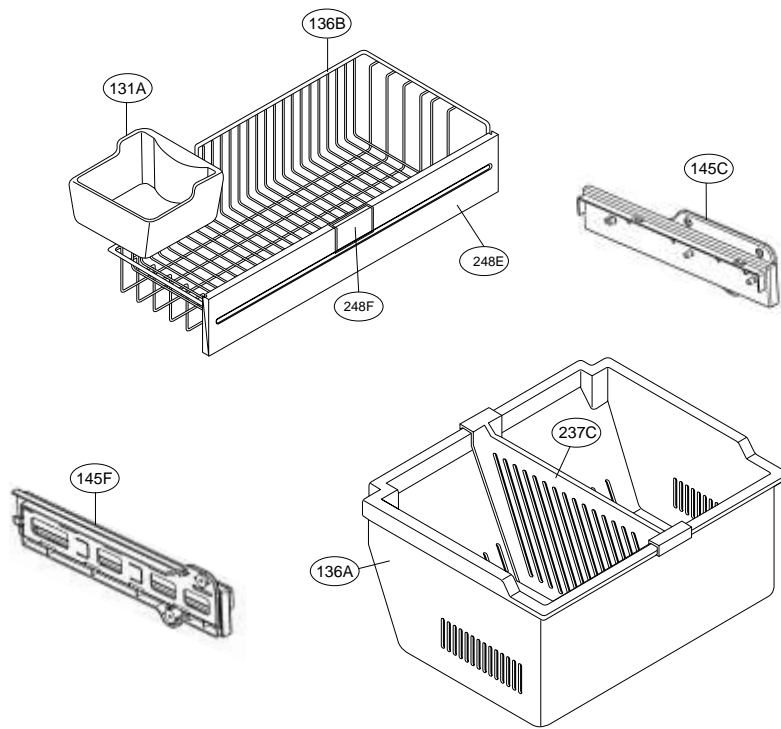

REFRIGERATOR PARTS

Caution: Use the part number to order part, not the position number.

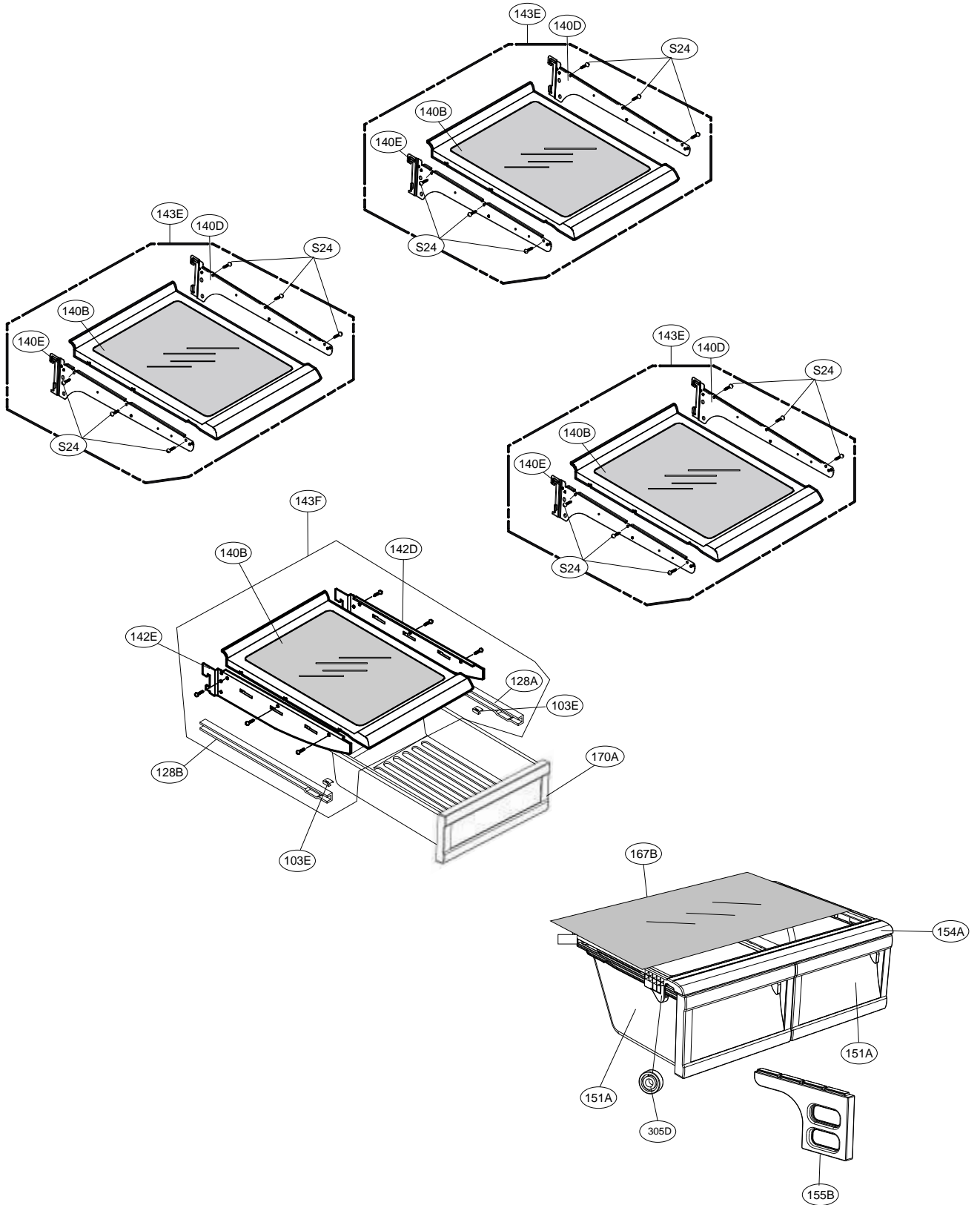

DISPENSER PARTS

Caution: Use the part number to order part, not the position number.

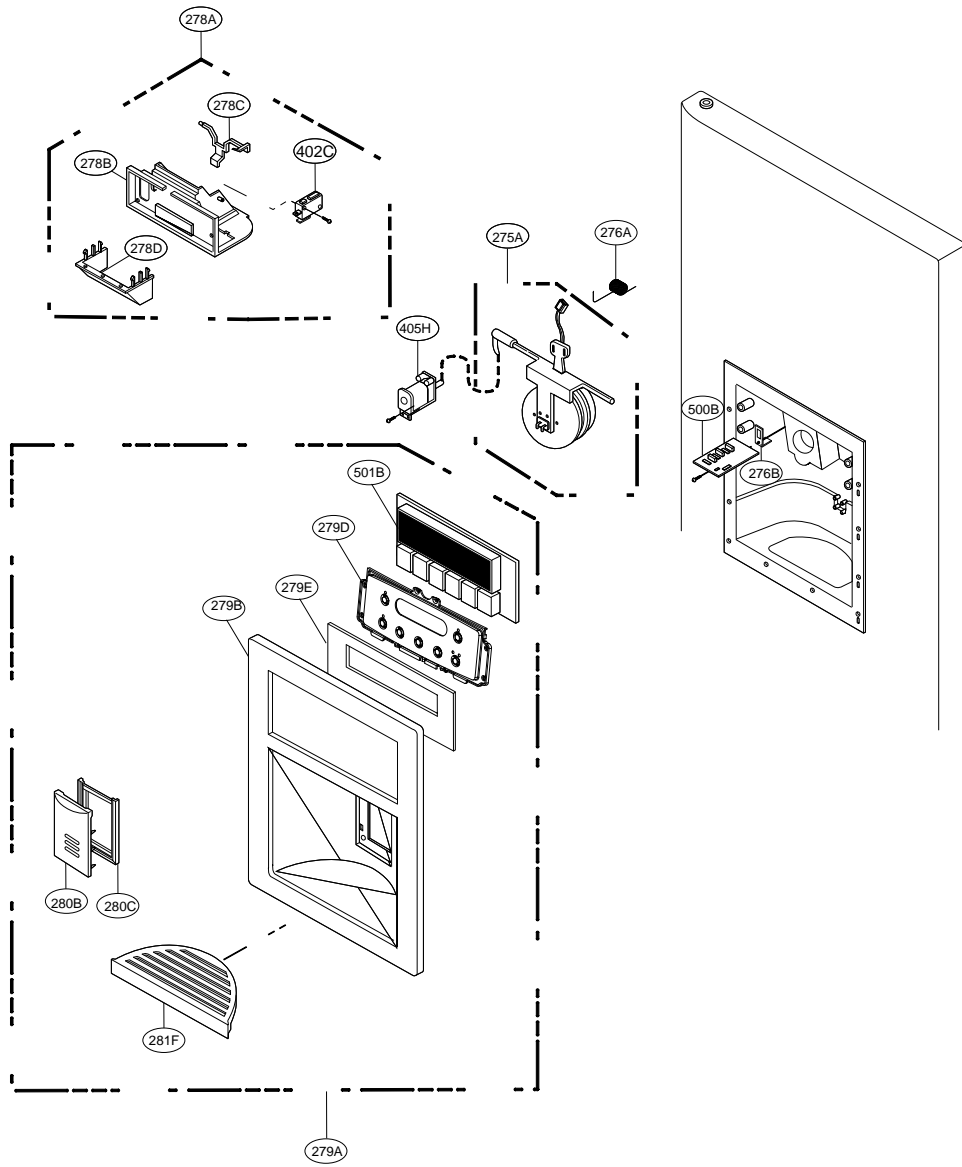

ICE MAKER & ICE BANK PARTS

Caution: Use the part number to order part, not the position number.

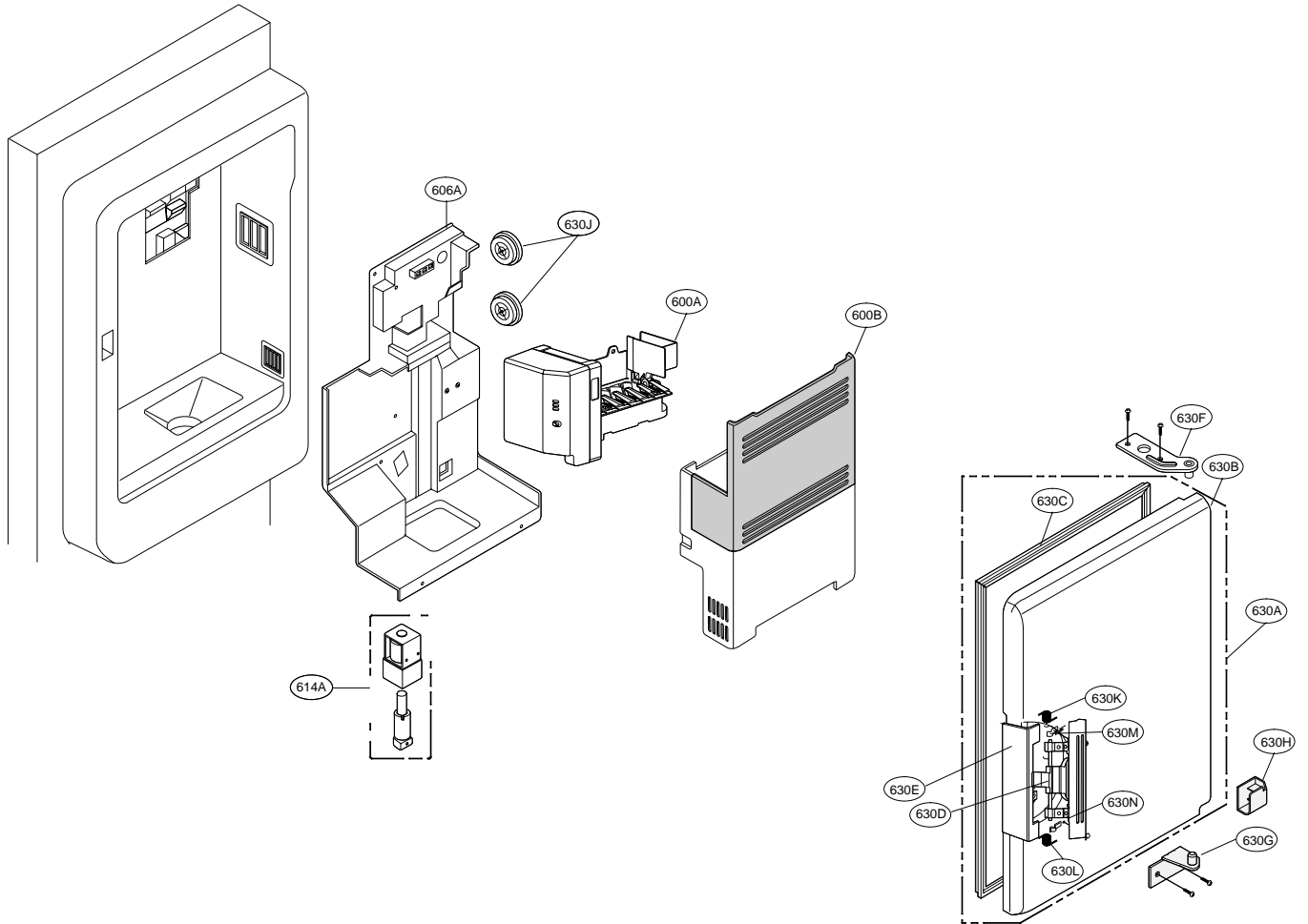

VALVE & WATER PARTS

Caution: Use the part number to order part, not the position number.

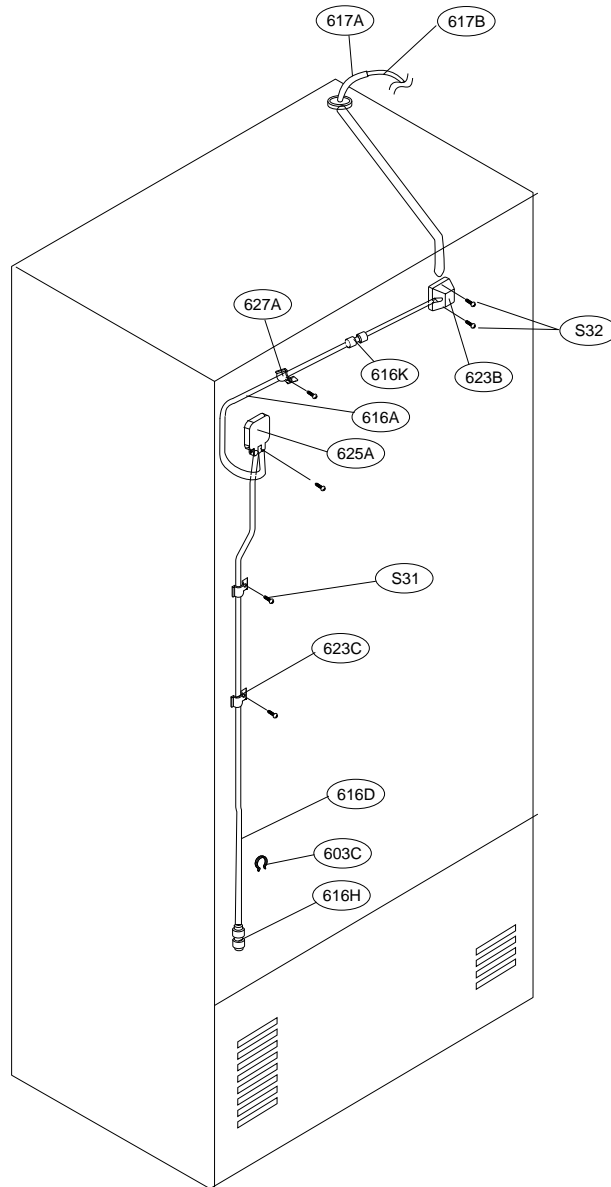

REPAIR PARTS LIST

795.78402.800

LOC NO	PART NO	DESCRIPTION	LOC NO	PART NO	DESCRIPTION
103A	3650JJ2003E	Handle,Rear	305B	4580JJ3001A	Roller
103B	3650JJ2003A	Handle,Rear	305C	4J04238A	Pin,Common
103C	3551JJ1015B	Cover Assembly,Lower	305C	4J04238A	Pin,Common
103E	5218JJ3001A	Rail,Slide	305D	4580JA3042A	Roller
103E	5218JJ3001A	Rail,Slide	307A	TC3A1748001	Compressor,Set Assembly
104E	4931JJ3002A	Holder Assembly,Gasket	308A	6748C0004D	Thermistor Assembly,PTC
105F	5070JJ3002A	Skirt,Lower	309A	6750C0004R	Overload Protect
106A	4779JA2003A	Leg Assembly,Adjust	310A	3550JA2059A	Cover,PTC
120B	5209JJ1002C	Duct Assembly,Multi	312A	5040JA3031A	Damper,Compressor
125D	4930JJ3007A	Holder,Bracket	313A	5040JJ3007A	Damper
128A	4975JJ2002A	Guide Assembly,Rail	313A	5040JJ3007A	Damper
128B	4975JJ2002B	Guide Assembly,Rail	314A	4620JA3009A	Stopper,Compressor
128E	4930JJ1025A	Holder,Rail	315A	3103JJ1001J	Base Assembly,Compressor
128F	4930JJ1025B	Holder,Rail	317A	5851JJ2002F	Drier Assembly
131A	MKK42003201	Bucket,Ice	318A	4930JA3034A	Holder,Drier
136A	3391JJ1011B	Tray Assembly,Drawer	319A	3390JJ0004A	Tray,Drip
136B	MJS42003601	Tray,Drawer	319C	MEA41997401	Guide,Fan
140B	5027JJ1039A	Shelf Assembly,Refrigerator	319E	4810JJ2005A	Bracket,Motor
140B	5027JJ1039A	Shelf Assembly,Refrigerator	323B	5403JJ1007A	Condenser Assembly,Wire
140D	MHL38615403	Shelf,Net	327A	5006JA3034A	Cap,Drain Tube
140E	MHL38615404	Shelf,Net	328B	4J04238A	Damper,Pipe
142D	5026JJ2001L	Shelf,Net	329A	5901JJ1005A	Fan Assembly
142E	5026JJ2001M	Shelf,Net	329C	ADP36665702	Fan Assembly
143E	5027JJ1013H	Shelf Assembly,Refrigerator	332A	AEB36834001	Grille Assembly,Fan
143F	5027JJ1013S	Shelf Assembly,Refrigerator	401A	6615JB2005C	Controller Assembly
145A	4930JJ2003A	Holder,Shelf	402A	6600JB3007A	Switch,Push Button
145B	4930JJ2004A	Holder,Shelf	402A	6600JB3007A	Switch,Push Button
145C	4975JJ2028C	Guide Assembly,Rail	404A	EAU52096201	Motor,DC
145F	4975JJ2028D	Guide Assembly,Rail	405A	4810JJ0001A	Bracket,Motor
147A	5074JJ1005A	Bucket,Dairy	405A	6421JB2002D	Solenoid,Reversing,Valve
147C	3550JJ1017A	Cover,Bucket	405B	5040JJ2001A	Damper,Motor Support
151A	3391JJ1038C	Tray Assembly,Vegetable	405C	5040JA2009B	Damper,Motor Support
151C	4940JJ2010A	KNOB,SHUTTER	405F	5040JA2004B	Damper,Motor Support
154A	MCK49494001	Cover,TV	405G	4811JJ2002J	Bracket Assembly,Motor
155B	4980JJ1016A	SUPPORTER,COVER TV	406B	6600JB1004A	Switch,Push Button
158A	3550JJ1104A	Cover,Lamp	407A	ADJ36834101	Duct Assembly,Connector
158E	MCK30060901	Cover,Lamp	409B	6912JK2002C	Lamp,Incandescent
167B	4890JL1002H	Shelf,Glass	409D	3034JJ1002B	Reflector,Lamp
170A	3391JJ2018B	TRAY ASSEMBLY,MEAT	410A	6621JK2003B	Drawing,Assembly
200A	ADC52734105	Door Assembly,Freezer	410C	4932JJ2006C	Connector,Tilt
201A	ADD36429906	Door Foam Assembly,Freezer	410G	OCZZJB2012K	Capacitor,Electric Appliance Film,Box
203A	4987JJ1004A	Gasket Assembly,Door	411A	6411JK1006L	Power Cord Assembly
207C	ACW36833901	Decor Assembly,Case	412D	6877JK2011A	Drawing,Assembly
212A	MEB42409803	Handle,Refrigerator	418A	5300JB1100J	Heater,Sheath
212B	MEB42518903	Handle,Freezer	420A	4681JB1029J	Motor,DC
212F	4810JJ3019B	Bracket,Handle	500B	6871JB2061B	PCB Assembly,Sub
212F	4810JJ3019B	Bracket,Handle	501A	EBR41956101	PCB Assembly
212G	4140JD1031A	Name Plate	501F	3551JJ1020A	Cover Assembly,PCB
212J	4620JJ3007B	Stopper,Handle	503D	3110JJ1021A	Case,Display
230A	ADC52734305	Door Assembly,Refrigerator(Right)	600A	AEQ36756907	Ice Maker Assembly,Kit
230B	ADC52734205	Door Assembly,Refrigerator(Left)	600B	AKC37000402	Bucket Assembly,Ice
231A	ADD36429806	Door Foam Assembly,Refrigerator	603B	4931JA3005B	Holder Assembly,Bracket
231B	ADD36429701	Door Foam Assembly,Refrigerator	603C	4930JA3091A	Holder,Bracket
233A	4987JJ2003E	Gasket Assembly,Door	603C	4930JA3091A	Holder,Bracket
233B	4987JJ2003G	Gasket Assembly,Door	603C	4930JA3091A	Holder,Bracket
233C	ACQ36835601	Cover Assembly,Front	603D	4930JA3093A	Holder,Bracket
233D	ACQ36835602	Cover Assembly,Front	606A	MCK41991601	Cover,Motor
237A	4974JJ2017A	Guide,Pitcher	610A	3550JJ2020A	Cover,Sensor
237C	4974JJ1021A	Guide,Drawer	611A	5231JA2006E	Filter Assembly,Water
241A	3550JL2006B	Cover,Tray	611B	5230JA2003A	Filter,Head
241B	5074JJ1019A	Bucket,Dairy	611C	3550JL1008F	Cover,Filter
241C	5005JJ2021B	Basket Assembly,Door	611D	3550JJ2028B	Cover,Filter
241D	5005JJ2022A	Basket Assembly,Door	614A	6421JA3001X	Solenoid,Reversing,Valve
241G	AAP37000301	Basket Assembly,Door	615A	4838JA2003B	Tank,Water
243A	4620JJ3006A	Stopper,Door	616A	5210JA3005X	Tube,Plastic
243A	4620JJ3006A	Stopper,Door	616D	5210JA3004B	Tube,Plastic
243B	4620JJ2009A	Stopper,Door	616H	4932JA3014A	Connector,Tube
243B	4620JJ2009A	Stopper,Door	616J	MCD38280801	Connector,Tube
248E	3806JJ1048A	Decor,Tray	616K	4932JA2003B	Connector,Tube
248F	3806JL2011C	Decor,Tray	617A	5210JA3005G	Tube,Plastic
249C	ACJ32471702	Connector Assembly	617B	4970JA3004G	Spring
249D	ACJ32471701	Connector Assembly	619A	MJX41869201	Valve,Water
249E	5218JA1010E	Rail,Slide	619B	3550JJ2024A	Cover,Valve
249F	5218JA1010F	Rail,Slide	623B	5006JJ2003A	Cap,Cover
249J	ACJ32308804	Connector Assembly	623C	4930JA3054A	Holder,Pipe
249K	ACJ32308803	Connector Assembly	625A	3550JA2184A	Cover,Tube
249L	MCK30136701	Cover,Connector	627A	4770JA3001A	Band
249M	MCK30136702	Cover,Connector	630A	3581JA1182G	Door Assembly,Freeze Room
250A	4270JJ3001E	Bar	630B	5433JA2071E	Door Foam Assembly,Home Bar
250B	4403JJ3001A	Connector Assembly	630C	MDS41996601	Gasket,Door
250B	4403JJ3001A	Connector Assembly	630E	MCR42600501	Decor,Handle
262E	4350JA3005B	Ring	630F	AEH36582801	Hinge Assembly,Upper
262H	4775JJ2019B	Hinge Assembly,Center	630G	AEH36582701	Hinge Assembly,Lower
271A	AEH36437001	Hinge Assembly,Upper	630H	MCK42523301	Cover,Home Bar
271C	AEH36437002	Hinge Assembly,Upper	630K	4970JA3044A	Spring
275A	5007JA3006R	Cap Assembly,Duct	630L	4970JA3045A	Spring
276A	4970JA3011C	Spring,Lever	630L	4970JJ3005A	Spring
276B	4930JA3043A	Holder,Lever	630M	4860JA3010A	Clamp
278A	3017JA2008A	Funnel Assembly	630N	4860JA3010B	Clamp
278C	4510JA2006A	Lever,Dispenser	631A	MCK41996401	Cover,Front
278D	MDR42523601	Funnel	903A	3550JJ0006A	Cover,Lower
279A	ACQ37160702	Cover Assembly,Dispenser	903B	4930JJ2021A	Holder,Cover(Lower)
279D	3110JJ1011E	Case,PCB	903D	6500JK1003A	Sensor
281A	ACQ36833802	Cover Assembly,Hinge	903E	6500JK1004A	Sensor
281D	3550JJ2043A	Cover,Hinge	B01	1STZJA3004F	Screw,Customized
281G	3390JJ1039A	Tray,Drain	B04	1STZJA3001B	Screw,Customized
281G	3550JJ2044A	Cover,Hinge	S01	1SZZJJ3010A	Screw,Customized
281H	4775JJ2011B	Hinge Assembly,Lower	S24	1SZZJA3011B	Screw,Customized
282B	4775JJ2019A	Hinge Assembly,Center	S24	1SZZJA3011B	Screw,Customized
282E	ACQ36833801	Cover Assembly,Hinge	S27	4J01424C	Screw,Customized
282F	3806JL2006D	Decor,Duct	S27	4J01424C	Screw,Customized
286A	4984JJ3003A	BUSH	S31	4J01425D	Screw,Customized
286A	4984JJ3003A	BUSH	S32	3J05696W	Screw,Customized
301A	5421JJ1001B	Evaporator Assembly	S38	4J00415D	Screw,Customized
304A	3551JJ2008B	Cover Assembly,Machinery(Rear)	S38	4J00415D	Screw,Customized
305B	4580JJ3001A	Roller			

LOC NO	PART NO	DESCRIPTION	LOC NO	PART NO	DESCRIPTION
103A	3650JJ2003H	Handle,Rear	304A	3551JJ2008B	Cover Assembly,Machinery(Rear)
103B	3650JJ2003D	Handle,Rear	305B	4580JJ3001A	Roller
103C	3551JJ1015H	Cover Assembly,Lower	305C	4J04238A	Pin,Common
103E	5218JJ3001A	Rail,Slide	305D	4580JA3042A	Roller
104E	4931JJ3002A	Holder Assembly,Gasket	307A	TCA31748001	Compressor,Set Assembly
105A	5250JA2009B	Tube,Drain	308A	6748C0004D	Thermistor Assembly,PTC
105F	5070JJ3002A	Skirt,Lower	309A	6750C0004R	Overload Protect
106A	4779JA2003A	Leg Assembly,Adjust	310A	3550JA2059A	Cover,PTC
120B	5209JJ1002C	Duct Assembly,Multi	312A	5040JA3031A	Damper,Compressor
125D	4930JJ3007A	Holder,Bracket	313A	5040JJ3007A	Damper
128A	4975JJ2002A	Guide Assembly,Rail	314A	4620JA3009A	Stopper,Compressor
128B	4975JJ2002B	Guide Assembly,Rail	315A	3103JJ1001J	Base Assembly,Compressor
128E	4930JJ1025A	Holder,Rail	317A	5851JJ2002F	Drier Assembly
128F	4930JJ1025B	Holder,Rail	318A	4930JA3034A	Holder,Drier
131A	MKK42003201	Bucket,Ice	319A	3390JJ0004A	Tray,Drip
136A	3391JJ1011B	Tray Assembly,Drawer	319C	MEA41997401	Guide,Fan
136B	MJS42003601	Tray,Drawer	319E	4810JJ2005A	Bracket,Motor
140B	5027JJ1039A	Shelf Assembly,Refrigerator	323B	5403JJ1007A	Condenser Assembly,Wire
140D	MHL38615403	Shelf,Net	327A	5006JA3034A	Cap,Drain Tube
140E	MHL38615404	Shelf,Net	328B	4J04328A	Damper,Pipe
142D	5026JJ2001L	Shelf,Net	329A	5901JJ1005A	Fan Assembly
142E	5026JJ2001M	Shelf,Net	329C	ADP36665702	Fan Assembly
143E	5027JJ1013H	Shelf Assembly,Refrigerator	332A	AEB36834001	Grille Assembly,Fan
143F	5027JJ1013S	Shelf Assembly,Refrigerator	401A	6615JB2005C	Controller Assembly
145A	4930JJ2003A	Holder,Shelf	402A	6600JB3007B	Switch,Push Button
145B	4930JJ2004A	Holder,Shelf	404A	EAU52096201	Motor,DC
145C	4975JJ2028C	Guide Assembly,Rail	405A	4810JJ0001A	Bracket,Motor
145F	4975JJ2028D	Guide Assembly,Rail	405B	5040JJ2001A	Damper,Motor Support
147A	5074JJ1005A	Bucket,Dairy	405C	5040JA2009B	Damper,Motor Support
147C	3550JJ1017A	Cover,Bucket	405F	5040JA2004B	Damper,Motor Support
151A	3391JJ1038C	Tray Assembly,Vegetable	405G	4811JJ2002J	Bracket Assembly,Motor
151C	4940JJ2010A	KNOB, SHUTTER	406B	6600JB1004A	Switch,Push Button
154A	MCK49494001	Cover,TV	407A	ADJ36834101	Duct Assembly,Connector
155B	4980JJ1016A	SUPPORTER,COVER TV	409B	6912JK2002C	Lamp,Incandescent
158A	3550JJ1104A	Cover,Lamp	409D	3034JJ1002B	Reflector,Lamp
158E	MCK30060901	Cover,Lamp	410A	6621JK2003B	Drawing,Assembly
167B	4890JL1002H	Shelf,Glass	410C	4932JJ2006C	Connector,Tilt
170A	3391JJ2018B	TRAY ASSEMBLY,MEAT	410G	0CZZJB2012K	Capacitor,Electric Appliance Film,Box
200A	ADC52734108	Door Assembly,Freezer	411A	6411JK1006L	Power Cord Assembly
201A	ADD36429909	Door Foam Assembly,Freezer	412D	6877JK2011A	Drawing,Assembly
203A	4987JJ1004Z	Gasket Assembly,Door	418A	5300JB1100J	Heater,Sheath
207C	ACW36833904	Decor Assembly,Case	420A	4681JB1029J	Motor,DC
212A	MEB42409801	Handle,Refrigerator	500B	6871JB2061B	PCB Assembly,Sub
212B	MEB42518901	Handle,Freezer	501A	EBR41956101	PCB Assembly
212G	4140JD1031A	Name Plate	501F	3551JJ1020A	Cover Assembly,PCB
212J	4620JJ3007B	Stopper,Handle	503D	3110JJ1021A	Case,Display
230A	ADC52734308	Door Assembly,Refrigerator(Right)	600A	AEQ36756907	Ice Maker Assembly,Kit
230B	ADC52734208	Door Assembly,Refrigerator(Left)	600B	AKC37000402	Bucket Assembly,Ice
231A	ADD36429810	Door Foam Assembly,Refrigerator	603B	4931JA3005B	Holder Assembly,Bracket
231B	ADD36429704	Door Foam Assembly,Refrigerator	603C	4930JA3091A	Holder,Bracket
233A	4987JJ2003N	Gasket Assembly,Door	603D	4930JA3093A	Holder,Bracket
233B	4987JJ2003P	Gasket Assembly,Door	606A	MCK41991601	Cover,Motor
233C	ACQ36835601	Cover Assembly,Front	610A	3550JJ2020A	Cover,Sensor
233D	ACQ36835602	Cover Assembly,Front	611A	5231JA2006E	Filter Assembly,Water
233E	4930JJ2028B	Holder,Gasket	611B	5230JA2003A	Filter,Head
233F	4930JJ2028A	Holder,Gasket	611C	3550JL1008F	Cover,Filter
233G	4430JJ2005B	Cam,Shaft	611D	3550JJ2028B	Cover,Filter
233H	4430JJ2005A	Cam,Shaft	614A	6421JA3001X	Solenoid,Reversing,Valve
237A	4974JJ2017A	Guide,Pitcher	615A	4838JA2003B	Tank,Water
237C	4974JJ1021A	Guide,Drawer	616A	5210JA3005X	Tube,Plastic
241A	3550JL2006B	Cover,Tray	616D	5210JA3004B	Tube,Plastic
241B	5074JJ1019A	Bucket,Dairy	616H	4932JA3014A	Connector,Tube
241C	5005JJ2021B	Basket Assembly,Door	616J	MCD38280801	Connector,Tube
241D	5005JJ2022A	Basket Assembly,Door	616K	4932JA2003B	Connector,Tube
241G	AAP37000301	Basket Assembly,Door	617A	5210JA3005G	Tube,Plastic
243A	4620JJ3006D	Stopper,Door	617B	4970JA3004G	Spring
243B	4620JJ2009A	Stopper,Door	619A	MJX41869201	Valve,Water
248E	3806JJ1048A	Decor,Tray	619B	3550JJ2024A	Cover,Valve
248F	3806JL2011C	Decor,Tray	623B	5006JJ2003A	Cap,Cover
249C	ACJ32471702	Connector Assembly	623C	4930JA3054A	Holder,Pipe
249D	ACJ32471701	Connector Assembly	625A	3550JA2184A	Cover,Tube
249E	5218JA1010E	Rail,Slide	627A	4770JA3001A	Band
249F	5218JA1010F	Rail,Slide	630A	3581JA1182G	Door Assembly,Freeze Room
249J	ACJ32308804	Connector Assembly	630B	5433JA2071E	Door Foam Assembly,Home Bar
249K	ACJ32308803	Connector Assembly	630C	MDS41996601	Gasket,Door
249L	MCK30136701	Cover,Connector	630E	MCR42600501	Decor,Handle
249M	MCK30136702	Cover,Connector	630F	AEH36582801	Hinge Assembly,Upper
250A	4270JJ3001E	Bar	630G	AEH36582701	Hinge Assembly,Lower
250B	4403JJ3001A	Connector Assembly	630H	MCK42523301	Cover,Home Bar
262E	4350JA3005B	Ring	630J	4987JA3025A	Gasket Assembly,Door
262H	4775JJ2019F	Hinge Assembly,Center	630K	4970JA3044A	Spring
271A	AEH36437001	Hinge Assembly,Upper	630L	4970JA3045A	Spring
271C	AEH36437002	Hinge Assembly,Upper	630M	4860JA3010A	Clamp
275A	5007JA3006R	Cap Assembly,Duct	630N	4860JA3010B	Clamp
276A	4970JA3011C	Spring,Lever	631A	MCK41996401	Cover,Front
276B	4930JA3043A	Holder,Lever	903A	3550JJ0006D	Cover,Lower
278A	3017JA2008B	Funnel Assembly	903B	4930JJ2021A	Holder,Cover(Lower)
278C	4510JA2006A	Lever,Dispenser	903D	6500JK1003A	Sensor
278D	MDR42523603	Funnel	903E	6500JK1004A	Sensor
279A	ACQ37160701	Cover Assembly,Dispenser	B01	1STZJA3004F	Screw,Customized
279D	3110JJ1011E	Case,PCB	B04	1STZJA3001B	Screw,Customized
281A	ACQ36833808	Cover Assembly,Hinge	S01	1SZZJJ3010A	Screw,Customized
281D	3550JJ2043A	Cover,Hinge	S24	1SZZJA3011B	Screw,Customized
281G	3550JJ2044A	Cover,Hinge	S24	1SZZJA3011B	Screw,Customized
281H	4775JJ2011B	Hinge Assembly,Lower	S27	4J01424C	Screw,Customized
282B	4775JJ2019E	Hinge Assembly,Center	S31	4J01425D	Screw,Customized
282E	ACQ36833807	Cover Assembly,Hinge	S32	3J05696W	Screw,Customized
282F	3806JL2006D	Decor,Duct	S38	4J00415D	Screw,Customized
286A	4984JJ3003A	BUSH	S38	4J00415D	Screw,Customized
301A	5421JJ1001B	Evaporator Assembly			

REPAIR PARTS LIST

795.78406.800

LOC NO	PART NO	DESCRIPTION	LOC NO	PART NO	DESCRIPTION
103A	3650JJ2003H	Handle,Rear	301A	5421JJ1001B	Evaporator Assembly
103B	3650JJ2003D	Handle,Rear	304A	3551JJ2008B	Cover Assembly,Machinery(Rear)
103C	3551JJ1015H	Cover Assembly,Lower	305B	4580JJ3001A	Roller
103E	5218JJ3001A	Rail,Slide	305C	4J04238A	Pin,Common
104E	4931JJ3002A	Holder Assembly,Gasket	305D	4580JA3042A	Roller
105A	5251JA3003B	Tube Assembly,Drain	307A	TCA31748001	Compressor,Set Assembly
105F	5070JJ3002A	Skirt,Lower	308A	6748C0004D	Thermistor Assembly,PTC
106A	4779JA2003A	Leg Assembly,Adjust	309A	6750C0004R	Overload Protect
120B	5209JJ1002C	Duct Assembly,Multi	310A	3550JA2059A	Cover,PTC
125D	4930JJ3007A	Holder,Bracket	312A	5040JA3031A	Damper,Compressor
128A	4975JJ2002A	Guide Assembly,Rail	313A	5040JJ3007A	Damper
128B	4975JJ2002B	Guide Assembly,Rail	314A	4620JA3009A	Stopper,Compressor
128E	4930JJ1025A	Holder,Rail	315A	3103JJ1001J	Base Assembly,Compressor
128F	4930JJ1025B	Holder,Rail	317A	5851JJ2002F	Drier Assembly
131A	MKK42003201	Bucket,Ice	318A	4930JA3034A	Holder,Drier
136A	3391JJ1011B	Tray Assembly,Drawer	319A	3390JJ0004A	Tray,Drip
136B	MJS42003601	Tray,Drawer	319C	MEA41997401	Guide,Fan
140B	5027JJ1039A	Shelf Assembly,Refrigerator	319E	4810JJ2005A	Bracket,Motor
140D	MHL38615403	Shelf,Net	323B	5403JJ1007A	Condenser Assembly,Wire
140E	MHL38615404	Shelf,Net	327A	5006JA3034A	Cap,Drain Tube
142D	5026JJ2001L	Shelf,Net	328B	4J04328A	Damper,Pipe
142E	5026JJ2001M	Shelf,Net	329A	5901JJ1005A	Fan Assembly
143E	5027JJ1013H	Shelf Assembly,Refrigerator	329C	ADP36665702	Fan Assembly
143F	5027JJ1013S	Shelf Assembly,Refrigerator	332A	AEB36834001	Grille Assembly,Fan
145A	4930JJ2003A	Holder,Shelf	401A	6615JB2005C	Controller Assembly
145B	4930JJ2004A	Holder,Shelf	402A	6600JB3007B	Switch,Push Button
145C	4975JJ2028C	Guide Assembly,Rail	404A	EAU52096201	Motor,DC
145F	4975JJ2028D	Guide Assembly,Rail	405A	4810JJ0001A	Bracket,Motor
147A	5074JJ1005A	Bucket,Dairy	405A	6421JB2002D	Solenoid,Reversing,Valve
147C	3550JJ1017A	Cover,Bucket	405B	5040JJ2001A	Damper,Motor Support
151A	3391JJ1038C	Tray Assembly,Vegetable	405C	5040JA2009B	Damper,Motor Support
151C	4940JJ2010A	KNOB,SHUTTER	405F	5040JA2004B	Damper,Motor Support
154A	MCK49494001	Cover,TV	405G	4811JJ2002J	Bracket Assembly,Motor
155B	4980JJ1016A	SUPPORTER,COVER TV	406B	6600JB1004A	Switch,Push Button
158A	3550JJ1104A	Cover,Lamp	407A	ADJ36834101	Duct Assembly,Connector
158E	MCK30060901	Cover,Lamp	409B	6912JK2002C	Lamp,Incandescent
167B	4890JL1002H	Shelf,Glass	409D	3034JJ1002B	Reflector,Lamp
170A	3391JJ2018B	TRAY ASSEMBLY,MEAT	410A	6621JK2003B	Drawing,Assembly
200A	ADC52734109	Door Assembly,Freezer	410C	4932JJ2006C	Connector,Tilt
201A	ADD36429910	Door Foam Assembly,Freezer	410G	0CZZJB2012K	Capacitor,Electric Appliance Film,Box
203A	4987JJ1004Z	Gasket Assembly,Door	411A	6411JK1006L	Power Cord Assembly
207C	ACW36833904	Decor Assembly,Case	412D	6877JK2011A	Drawing,Assembly
212A	AED37133301	Handle Assembly,Refrigerator	418A	5300JB1100J	Heater,Sheath
212B	AED37133501	Handle Assembly,Freezer	420A	4681JB1029J	Motor,DC
212G	4140JD1031A	Name Plate	500B	6871JB2061B	PCB Assembly,Sub
212J	4620JJ3007B	Stopper,Handle	501A	EBR41956101	PCB Assembly
212K	4620JJ3007B	Stopper,Handle	501F	3551JJ1020A	Cover Assembly,PCB
230A	ADC52734309	Door Assembly,Refrigerator(Right)	503D	3110JJ1021A	Case,Display
230B	ADC52734209	Door Assembly,Refrigerator(Left)	600A	AEQ36756907	Ice Maker Assembly,Kit
231A	ADD36429812	Door Foam Assembly,Refrigerator	600B	AKC37000402	Bucket Assembly,Ice
231B	ADD36429705	Door Foam Assembly,Refrigerator	603B	4931JA3005B	Holder Assembly,Bracket
233A	4987JJ2003N	Gasket Assembly,Door	603C	4930JA3091A	Holder,Bracket
233B	4987JJ2003P	Gasket Assembly,Door	603D	4930JA3093A	Holder,Bracket
233C	ACQ36835601	Cover Assembly,Front	606A	MCK41991601	Cover,Motor
233D	ACQ36835602	Cover Assembly,Front	610A	3550JJ2020A	Cover,Sensor
233E	4930JJ2028B	Holder,Gasket	611A	5231JA2006E	Filter Assembly,Water
233F	4930JJ2028A	Holder,Gasket	611B	5230JA2003A	Filter,Head
233G	4430JJ2005B	Cam,Shaft	611C	3550JL1008F	Cover,Filter
233H	4430JJ2005A	Cam,Shaft	611D	3550JJ2028B	Cover,Filter
237A	4974JJ2017A	Guide,Pitcher	614A	6421JA3001X	Solenoid,Reversing,Valve
237C	4974JJ1021A	Guide,Drawer	615A	4838JA2003B	Tank,Water
241A	3550JL2006B	Cover,Tray	616A	5210JA3005X	Tube,Plastic
241B	5074JJ1019A	Bucket,Dairy	616D	5210JA3004B	Tube,Plastic
241C	5005JJ2021B	Basket Assembly,Door	616H	4932JA3014A	Connector,Tube
241D	5005JJ2022A	Basket Assembly,Door	616J	MCD38280801	Connector,Tube
241G	AAP37000301	Basket Assembly,Door	616K	4932JA2003B	Connector,Tube
243A	4620JJ3006D	Stopper,Door	617A	5210JA3005G	Tube,Plastic
243B	4620JJ2009A	Stopper,Door	617B	4970JA3004G	Spring
248E	3806JJ1048A	Decor,Tray	619A	MJX41869201	Valve,Water
248F	3806JL2011C	Decor,Tray	619B	3550JJ2024A	Cover,Valve
249C	ACJ32471702	Connector Assembly	623B	5006JJ2003A	Cap,Cover
249D	ACJ32471701	Connector Assembly	623C	4770JA3001A	Band
249E	5218JA1010E	Rail,Slide	625A	3550JA2184A	Cover,Tube
249F	5218JA1010F	Rail,Slide	627A	4930JA3054A	Holder,Pipe
249J	ACJ32308804	Connector Assembly	630A	3581JA1182G	Door Assembly,Freeze Room
249K	ACJ32308803	Connector Assembly	630B	5433JA2071E	Door Foam Assembly,Home Bar
249L	MCK30136701	Cover,Connector	630C	MDS41996601	Gasket,Door
249M	MCK30136702	Cover,Connector	630E	MCR42600501	Decor,Handle
250A	4270JJ3001E	Bar	630F	AEH36582801	Hinge Assembly,Upper
250B	4403JJ3001A	Connector Assembly	630G	AEH36582701	Hinge Assembly,Lower
262E	4350JA3005B	Ring	630H	MCK42523301	Cover,Home Bar
262H	4775JJ2019F	Hinge Assembly,Center	630J	4987JA3025A	Gasket Assembly,Door
271A	AEH36437001	Hinge Assembly,Upper	630K	4970JA3044A	Spring
271C	AEH36437002	Hinge Assembly,Upper	630L	4970JA3045A	Spring
275A	5007JA3006R	Cap Assembly,Duct	630M	4860JA3010A	Clamp
276A	4970JA3011C	Spring,Lever	630N	4860JA3010B	Clamp
276B	4930JA3043A	Holder,Lever	631A	MCK41996401	Cover,Front
278A	3017JA2008B	Funnel Assembly	903A	3550JJ0006D	Cover,Lower
278C	4510JA2006A	Lever,Dispenser	903B	4930JJ2021A	Holder,Cover(Lower)
278D	MDR42523603	Funnel	903D	6500JK1003A	Sensor
279A	ACQ37160701	Cover Assembly,Dispenser	903E	6500JK1004A	Sensor
281A	ACQ36833808	Cover Assembly,Hinge	B01	1STZJA3004F	Screw,Customized
281D	3550JJ2043A	Cover,Hinge	B04	1STZJA3001B	Screw,Customized
281G	3550JJ2044A	Cover,Hinge	S01	1SZZJJ3010A	Screw,Customized
281H	4775JJ2011B	Hinge Assembly,Lower	S24	1SZZJA3011B	Screw,Customized
282B	4775JJ2019E	Hinge Assembly,Center	S27	4J01424C	Screw,Customized
282E	ACQ36833807	Cover Assembly,Hinge	S31	4J01425D	Screw,Customized
282F	3806JL2006D	Decor,Duct	S32	3J05696W	Screw,Customized
286A	4984JJ3003A	BUSH	S38	4J00415D	Screw,Customized

LOC NO	PART NO	DESCRIPTION	LOC NO	PART NO	DESCRIPTION
103A	3650JJ2003H	Handle,Rear	301A	5421JJ1001B	Evaporator Assembly
103B	3650JJ2003D	Handle,Rear	304A	3551JJ2008B	Cover Assembly,Machinery(Rear)
103C	3551JJ1015H	Cover Assembly,Lower	305B	4580JJ3001A	Roller
103E	5218JJ3001A	Rail,Slide	305C	4J04238A	Pin,Common
104E	4931JJ3002A	Holder Assembly,Gasket	305D	4580JA3042A	Roller
105A	5251JA3003B	Tube Assembly,Drain	307A	TCA31748001	Compressor,Set Assembly
105F	5070JJ3002A	Skirt,Lower	308A	6748C0004D	Thermistor Assembly,PTC
106A	4779JA2003A	Leg Assembly,Adjust	309A	6750C0004R	Overload Protect
120B	5209JJ1002C	Duct Assembly,Multi	310A	3550JA2059A	Cover,PTC
125D	4930JJ3007A	Holder,Bracket	312A	5040JA3031A	Damper,Compressor
128A	4975JJ2002A	Guide Assembly,Rail	313A	5040JJ3007A	Damper
128B	4975JJ2002B	Guide Assembly,Rail	314A	4620JA3009A	Stopper,Compressor
128E	4930JJ1025A	Holder,Rail	315A	3103JJ1001J	Base Assembly,Compressor
128F	4930JJ1025B	Holder,Rail	317A	5851JJ2002F	Drier Assembly
131A	MKK42003201	Bucket,Ice	318A	4930JA3034A	Holder,Drier
136A	3391JJ1011B	Tray Assembly,Drawer	319A	3390JJ0004A	Tray,Drip
136B	MJS42003601	Tray,Drawer	319C	MEA41997401	Guide,Fan
140B	5027JJ1039A	Shelf Assembly,Refrigerator	319E	4810JJ2005A	Bracket,Motor
140D	MHL38615403	Shelf,Net	323B	5403JJ1007A	Condenser Assembly,Wire
140E	MHL38615404	Shelf,Net	327A	5006JA3034A	Cap,Drain Tube
142D	5026JJ2001L	Shelf,Net	328B	4J04328A	Damper,Pipe
142E	5026JJ2001M	Shelf,Net	329A	5901JJ1005A	Fan Assembly
143E	5027JJ1013H	Shelf Assembly,Refrigerator	329C	ADP36665702	Fan Assembly
143F	5027JJ1013S	Shelf Assembly,Refrigerator	332A	AEB36834001	Grille Assembly,Fan
145A	4930JJ2003A	Holder,Shelf	401A	6615JB2005C	Controller Assembly
145B	4930JJ2004A	Holder,Shelf	402A	6600JB3007B	Switch,Push Button
145C	4975JJ2028C	Guide Assembly,Rail	404A	EAU52096201	Motor,DC
145F	4975JJ2028D	Guide Assembly,Rail	405A	4810JJ0001A	Bracket,Motor
146A	5004JJ1071A	BASKET,DOOR	405A	6421JB2002D	Solenoid,Reversing,Valve
147A	5074JJ1005A	Bucket,Dairy	405B	5040JJ2001A	Damper,Motor Support
147C	3550JJ1017A	Cover,Bucket	405C	5040JA2009B	Damper,Motor Support
151A	3391JJ1038C	Tray Assembly,Vegetable	405F	5040JA2004B	Damper,Motor Support
151C	4940JJ2010A	KNOB,SHUTTER	405G	4811JJ2002J	Bracket Assembly,Motor
154A	MCK49494001	Cover,TV	406B	6600JB1004A	Switch,Push Button
155B	4980JJ1016A	SUPPORTER,COVER TV	407A	ADJ36834101	Duct Assembly,Connector
158A	3550JJ1104A	Cover,Lamp	409B	6912JK2002C	Lamp,Incandescent
158E	MCK30060901	Cover,Lamp	409D	3034JJ1002B	Reflector,Lamp
167B	4890JL1002H	Shelf,Glass	410A	6621JK2003B	Drawing,Assembly
170A	3391JJ2018B	TRAY ASSEMBLY,MEAT	410C	4932JJ2006C	Connector,Tilt
200A	ADC52734108	Door Assembly,Freezer	410G	0CZZJB2012K	Capacitor,Electric Appliance Film,Box
201A	ADD36429909	Door Foam Assembly,Freezer	411A	6411JK1006L	Power Cord Assembly
203A	4987JJ1004Z	Gasket Assembly,Door	412D	6877JK2011A	Drawing,Assembly
207C	ACW36833904	Decor Assembly,Case	418A	5300JB1100J	Heater,Sheath
212A	MEB42409801	Handle,Refrigerator	420A	4681JB1029J	Motor,DC
212B	MEB42518901	Handle,Freezer	500B	6871JB2061B	PCB Assembly,Sub
212G	4140JD1031A	Name Plate	501A	EBR41956101	PCB Assembly
212J	4620JJ3007B	Stopper,Handle	501F	3551JJ1020A	Cover Assembly,PCB
212K	4620JJ3007B	Stopper,Handle	503D	3110JJ1021A	Case,Display
230A	ADC52734308	Door Assembly,Refrigerator(Right)	600A	AEQ36756907	Ice Maker Assembly,Kit
230B	ADC52734208	Door Assembly,Refrigerator(Left)	600B	AKC37000402	Bucket Assembly,Ice
231A	ADD36429810	Door Foam Assembly,Refrigerator	603B	4931JA3005B	Holder Assembly,Bracket
231B	ADD36429704	Door Foam Assembly,Refrigerator	603C	4930JA3091A	Holder,Bracket
233A	4987JJ2003N	Gasket Assembly,Door	603D	4930JA3093A	Holder,Bracket
233B	4987JJ2003P	Gasket Assembly,Door	606A	MCK41991601	Cover,Motor
233C	ACQ36835601	Cover Assembly,Front	610A	3550JJ2020A	Cover,Sensor
233D	ACQ36835602	Cover Assembly,Front	611A	5231JA2006E	Filter Assembly,Water
233E	4930JJ2028B	Holder,Gasket	611B	5230JA2003A	Filter,Head
233F	4930JJ2028A	Holder,Gasket	611C	3550JL1008F	Cover,Filter
233G	4430JJ2005B	Cam,Shaft	611D	3550JJ2028B	Cover,Filter
233H	4430JJ2005A	Cam,Shaft	614A	6421JA3001X	Solenoid,Reversing,Valve
237A	4974JJ2017A	Guide,Pitcher	615A	4838JA2003B	Tank,Water
237C	4974JJ1021A	Guide,Drawer	616A	5210JA3005X	Tube,Plastic
241A	3550JL2006B	Cover,Tray	616D	5210JA3004B	Tube,Plastic
241B	5074JJ1019A	Bucket,Dairy	616H	4932JA3014A	Connector,Tube
241C	5005JJ2021B	Basket Assembly,Door	616J	MCD38280801	Connector,Tube
241D	5005JJ2022A	Basket Assembly,Door	616K	4932JA2003B	Connector,Tube
241G	AAP37000301	Basket Assembly,Door	617A	5210JA3005G	Tube,Plastic
243A	4620JJ3006D	Stopper,Door	617B	4970JA3004G	Spring
243B	4620JJ2009A	Stopper,Door	619A	MJX41869201	Valve,Water
248E	3806JJ1048A	Decor,Tray	619B	3550JJ2024A	Cover,Valve
248F	3806JL2011C	Decor,Tray	623B	5006JJ2003A	Cap,Cover
249C	ACJ32471702	Connector Assembly	623C	4770JA3001A	Band
249D	ACJ32471701	Connector Assembly	625A	3550JA2184A	Cover,Tube
249E	5218JA1010E	Rail,Slide	627A	4930JA3054A	Holder,Pipe
249F	5218JA1010F	Rail,Slide	630A	3581JA1182G	Door Assembly,Freeze Room
249J	ACJ32308804	Connector Assembly	630B	5433JA2071E	Door Foam Assembly,Home Bar
249K	ACJ32308803	Connector Assembly	630C	MDS41996601	Gasket,Door
249L	MCK30136701	Cover,Connector	630E	MCR42600501	Decor,Handle
249M	MCK30136702	Cover,Connector	630F	AEH36582801	Hinge Assembly,Upper
250A	4270JJ3001E	Bar	630G	AEH36582701	Hinge Assembly,Lower
250B	4403JJ3001A	Connector Assembly	630H	MCK42523301	Cover,Home Bar
262E	4350JA3005B	Ring	630J	4987JA3025A	Gasket Assembly,Door
262H	4775JJ2019F	Hinge Assembly,Center	630K	4970JA3044A	Spring
271A	AEH36437001	Hinge Assembly,Upper	630L	4970JA3045A	Spring
271C	AEH36437002	Hinge Assembly,Upper	630M	4860JA3010A	Clamp
275A	5007JA3006R	Cap Assembly,Duct	630N	4860JA3010B	Clamp
276A	4970JA3011C	Spring,Lever	631A	MCK41996401	Cover,Front
276B	4930JA3043A	Holder,Lever	903A	3550JJ0006D	Cover,Lower
278A	3017JA2008B	Funnel Assembly	903B	4930JJ2021A	Holder,Cover(Lower)
278C	4510JA2006A	Lever,Dispenser	903D	6500JK1003A	Sensor
278D	MDR42523603	Funnel	903E	6500JK1004A	Sensor
279A	ACQ37160701	Cover Assembly,Dispenser	B01	1STZJA3004F	Screw,Customized
281A	ACQ36833808	Cover Assembly,Hinge	B04	1STZJA3001B	Screw,Customized
281D	3550JJ2043A	Cover,Hinge	S01	1SZZJJ3010A	Screw,Customized
281G	3550JJ2044A	Cover,Hinge	S24	1SZZJA3011B	Screw,Customized
281H	4775JJ2011B	Hinge Assembly,Lower	S27	4J01424C	Screw,Customized
282B	4775JJ2019E	Hinge Assembly,Center	S31	4J01425D	Screw,Customized
282E	ACQ36833807	Cover Assembly,Hinge	S32	3J05696W	Screw,Customized
282F	3806JL2006D	Decor,Duct	S38	4J00415D	Screw,Customized
286A	4984JJ3003A	BUSH			

LOC NO	PART NO	DESCRIPTION	LOC NO	PART NO	DESCRIPTION
103A	3650.JJ2003E	Handle,Rear	286A	4984.JJ3003A	BUSH
103B	3650.JJ2003A	Handle,Rear	301A	5421.JJ1001B	Evaporator Assembly
103C	3551.JJ1015B	Cover Assembly,Lower	304A	3551.JJ2008B	Cover Assembly,Machinery(Rear)
103E	5218.JJ3001A	Rail,Slide	305B	4580.JJ3001A	Roller
104E	4931.JJ3002A	Holder Assembly,Gasket	305C	4J04238A	Pin,Common
105A	5251.JA3003B	Tube Assembly,Drain	305D	4580.JA3042A	Roller
105F	5070.JJ3002A	Skirt,Lower	307A	TCA31748001	Compressor,Set Assembly
106A	4779.JA2003A	Leg Assembly,Adjust	308A	6748.C0004D	Thermistor Assembly,PTC
120B	5209.JJ1002C	Duct Assembly,Multi	309A	6750.C0004R	Overload Protect
125D	4930.JJ3007A	Holder,Bracket	310A	3550.JA2059A	Cover,PTC
128A	4975.JJ2002A	Guide Assembly,Rail	312A	5040.JA3031A	Damper,Compressor
128B	4975.JJ2002B	Guide Assembly,Rail	313A	5040.JJ3007A	Damper
128E	4930.JJ1025A	Holder,Rail	314A	4620.JA3009A	Stopper,Compressor
128F	4930.JJ1025B	Holder,Rail	315A	3103.JJ1001J	Base Assembly,Compressor
131A	MKK42003201	Bucket,Ice	317A	5851.JJ2002F	Drier Assembly
136A	3391.JJ1011B	Tray Assembly,Drawer	318A	4930.JA3034A	Holder,Drier
136B	MJS42003601	Tray,Drawer	319A	3390.JJ0004A	Tray,Drip
140B	5027.JJ1039A	Shelf Assembly,Refrigerator	319C	MEA41997401	Guide,Fan
140D	MHL38615403	Shelf,Net	319E	4810.JJ2005A	Bracket,Motor
140E	MHL38615404	Shelf,Net	323B	5403.JJ1007A	Condenser Assembly,Wire
142D	5026.JJ2001L	Shelf,Net	327A	5006.JA3034A	Cap,Drain Tube
142E	5026.JJ2001M	Shelf,Net	328B	4J04238A	Damper,Pipe
143E	5027.JJ1013H	Shelf Assembly,Refrigerator	329A	5901.JJ1005A	Fan Assembly
143F	5027.JJ1013S	Shelf Assembly,Refrigerator	329C	ADP36665702	Fan Assembly
145A	4930.JJ2003A	Holder,Shelf	332A	AEB36834001	Grille Assembly,Fan
145B	4930.JJ2004A	Holder,Shelf	401A	6615.JB2005C	Controller Assembly
145C	4975.JJ2028C	Guide Assembly,Rail	402A	6600.JB3007A	Switch,Push Button
145F	4975.JJ2028D	Guide Assembly,Rail	404A	EAU52096201	Motor,DC
146A	5004.JJ1071A	BASKET,DOOR	405A	4810.JJ0001A	Bracket,Motor
147A	5074.JJ1005A	Bucket,Dairy	405A	6421.JB2002D	Solenoid,Reversing,Valve
147C	3550.JJ1017A	Cover,Bucket	405B	5040.JJ2001A	Damper,Motor Support
151A	3391.JJ1038C	Tray Assembly,Vegetable	405C	5040.JA2009B	Damper,Motor Support
151C	4940.JJ2010A	KNOB,SHUTTER	405F	5040.JA2004B	Damper,Motor Support
154A	MCK49494001	Cover,TV	405G	4811.JJ2002J	Bracket Assembly,Motor
155B	4980.JJ1016A	SUPPORTER,COVER TV	406B	6600.JB1004A	Switch,Push Button
158A	3550.JJ1104A	Cover,Lamp	407A	ADJ36834101	Duct Assembly,Connector
158E	MCK30060901	Cover,Lamp	409B	6912.JK2002C	Lamp,Incandescent
167B	4890.JL1002H	Shelf,Glass	409D	3034.JJ1002B	Reflector,Lamp
170A	3391.JJ2018B	TRAY ASSEMBLY,MEAT	410A	6621.JK2003B	Drawing,Assembly
200A	ADC52734105	Door Assembly,Freezer	410C	4932.JJ2006C	Connector,Tilt
201A	ADD36429906	Door Foam Assembly,Freezer	410G	0CZZ.JB2012K	Capacitor,Electric Appliance Film,Box
203A	4987.JJ1004A	Gasket Assembly,Door	411A	6411.JK1006L	Power Cord Assembly
207C	ACW36833901	Decor Assembly,Case	412D	6877.JK2011A	Drawing,Assembly
212A	MEB42409803	Handle,Refrigerator	418A	5300.JB1100J	Heater,Sheath
212B	MEB42518903	Handle,Freezer	420A	4681.JB1029J	Motor,DC
212F	4810.JJ3019B	Bracket,Handle	500B	6871.JB2061B	PCB Assembly,Sub
212F	4810.JJ3019B	Bracket,Handle	501A	EBR41956101	PCB Assembly
212G	4140.JD1031A	Name Plate	501F	3551.JJ1020A	Cover Assembly,PCB
212J	4620.JJ3007B	Stopper,Handle	503D	3110.JJ1021A	Case,Display
230A	ADC52734305	Door Assembly,Refrigerator(Right)	600A	AEQ36756907	Ice Maker Assembly,Kit
230B	ADC52734205	Door Assembly,Refrigerator(Left)	600B	AKC37000402	Bucket Assembly,Ice
231A	ADD36429806	Door Foam Assembly,Refrigerator	603B	4931.JA3005B	Holder Assembly,Bracket
231B	ADD36429701	Door Foam Assembly,Refrigerator	603C	4930.JA3091A	Holder,Bracket
233A	4987.JJ2003E	Gasket Assembly,Door	603D	4930.JA3093A	Holder,Bracket
233B	4987.JJ2003G	Gasket Assembly,Door	606A	MCK41991601	Cover,Motor
233C	ACQ36835601	Cover Assembly,Front	610A	3550.JJ2020A	Cover,Sensor
233D	ACQ36835602	Cover Assembly,Front	611A	5231.JA2006E	Filter Assembly,Water
233E	4930.JJ2028B	Holder,Gasket	611B	5230.JA2003A	Filter,Head
233F	4930.JJ2028A	Holder,Gasket	611C	3550.JL1008F	Cover,Filter
233G	4430.JJ2005B	Cam,Shaft	611D	3550.JJ2028B	Cover,Filter
233H	4430.JJ2005A	Cam,Shaft	614A	6421.JA3001X	Solenoid,Reversing,Valve
237A	4974.JJ2017A	Guide,Pitcher	615A	4838.JA2003B	Tank,Water
237C	4974.JJ1021A	Guide,Drawer	616A	5210.JA3005X	Tube,Plastic
241A	3550.JL2006B	Cover,Tray	616D	5210.JA3004B	Tube,Plastic
241B	5074.JJ1019A	Bucket,Dairy	616H	4932.JA3014A	Connector,Tube
241C	5005.JJ2021B	Basket Assembly,Door	616J	MCD38280801	Connector,Tube
241D	5005.JJ2022A	Basket Assembly,Door	616K	4932.JA2003B	Connector,Tube
241G	AAP37000301	Basket Assembly,Door	617A	5210.JA3005G	Tube,Plastic
243A	4620.JJ3006A	Stopper,Door	617B	4970.JA3004G	Spring
243B	4620.JJ2009A	Stopper,Door	619A	MJX41869201	Valve,Water
248E	3806.JJ1048A	Decor,Tray	619B	3550.JJ2024A	Cover,Valve
248F	3806.JL2011C	Decor,Tray	623B	5006.JJ2003A	Cap,Cover
249C	ACJ32471702	Connector Assembly	623C	4770.JA3001A	Band
249D	ACJ32471701	Connector Assembly	625A	3550.JA2184A	Cover,Tube
249E	5218.JA1010E	Rail,Slide	627A	4930.JA3054A	Holder,Pipe
249F	5218.JA1010F	Rail,Slide	630A	3581.JA1182G	Door Assembly,Freeze Room
249J	ACJ32308804	Connector Assembly	630B	5433.JA2071E	Door Foam Assembly,Home Bar
249K	ACJ32308803	Connector Assembly	630C	MDS41996601	Gasket,Door
249L	MCK30136701	Cover,Connector	630E	MCR42600501	Decor,Handle
249M	MCK30136702	Cover,Connector	630F	AEH36582801	Hinge Assembly,Upper
250A	4270.JJ3001E	Bar	630G	AEH36582701	Hinge Assembly,Lower
250B	4403.JJ3001A	Connector Assembly	630H	MCK42523301	Cover,Home Bar
262E	4350.JA3005B	Ring	630J	4987.JA3025A	Gasket Assembly,Door
262H	4775.JJ2019B	Hinge Assembly,Center	630K	4970.JA3044A	Spring
271A	AEH36437001	Hinge Assembly,Upper	630L	4970.JA3045A	Spring
271C	AEH36437002	Hinge Assembly,Upper	630M	4860.JA3010A	Clamp
275A	5007.JA3006R	Cap Assembly,Duct	630N	4860.JA3010B	Clamp
276A	4970.JA3011C	Spring,Lever	631A	MCK41996401	Cover,Front
276B	4930.JA3043A	Holder,Lever	903A	3550.JJ0006A	Cover,Lower
278A	3017.JA2008A	Funnel Assembly	903B	4930.JJ2021A	Holder,Cover(Lower)
278C	4510.JA2006A	Lever,Dispenser	903D	6500.JK1003A	Sensor
278D	MDR42523601	Funnel	903E	6500.JK1004A	Sensor
279A	ACQ37160702	Cover Assembly,Dispenser	B01	1STZ.JA3004F	Screw,Customized
281A	ACQ36833802	Cover Assembly,Hinge	B04	1STZ.JA3001B	Screw,Customized
281D	3550.JJ2043A	Cover,Hinge	S01	1SZZ.JJ3010A	Screw,Customized
281G	3550.JJ2044A	Cover,Hinge	S24	1SZZ.JA3011B	Screw,Customized
281H	4775.JJ2011B	Hinge Assembly,Lower	S27	4J01424C	Screw,Customized
282B	4775.JJ2019A	Hinge Assembly,Center	S31	4J01425D	Screw,Customized
282E	ACQ36833801	Cover Assembly,Hinge	S32	3J05696W	Screw,Customized
282F	3806.JL2006D	Decor,Duct	S38	4J00415D	Screw,Customized

795.78409.800

LOC NO	PART NO	DESCRIPTION	LOC NO	PART NO	DESCRIPTION
103A	3650JJ2003M	Handle,Rear	286A	4984JJ3003A	BUSH
103B	3650JJ2003L	Handle,Rear	301A	5421JJ1001B	Evaporator Assembly
103C	3551JJ1015F	Cover Assembly,Lower	304A	3551JJ2008B	Cover Assembly,Machinery(Rear)
103E	5218JJ3001A	Rail,Slide	305B	4580JJ3001A	Roller
104E	4931JJ3002A	Holder Assembly,Gasket	305C	4J04238A	Pin,Common
105A	5251JA3003B	Tube Assembly,Drain	305D	4580JA3042A	Roller
105F	5070JJ3002A	Skirt,Lower	307A	TCA31748001	Compressor,Set Assembly
106A	4779JA2003A	Leg Assembly,Adjust	308A	6748C0004D	Thermistor Assembly,PTC
120B	5209JJ1002C	Duct Assembly,Multi	309A	6750C0004R	Overload Protect
125D	4930JJ3007A	Holder,Bracket	310A	3550JA2059A	Cover,PTC
128A	4975JJ2002A	Guide Assembly,Rail	312A	5040JA3031A	Damper,Compressor
128B	4975JJ2002B	Guide Assembly,Rail	313A	5040JJ3007A	Damper
128E	4930JJ1025A	Holder,Rail	314A	4620JA3009A	Stopper,Compressor
128F	4930JJ1025B	Holder,Rail	315A	3103JJ1001J	Base Assembly,Compressor
131A	MKK42003201	Bucket,Ice	317A	5851JJ2002F	Drier Assembly
136A	3391JJ1011B	Tray Assembly,Drawer	318A	4930JA3034A	Holder,Drier
136B	MJS42003601	Tray,Drawer	319A	3390JJ0004A	Tray,Drip
140B	5027JJ1039A	Shelf Assembly,Refrigerator	319C	MEA41997401	Guide,Fan
140D	MHL38615403	Shelf,Net	319E	4810JJ2005A	Bracket,Motor
140E	MHL38615404	Shelf,Net	323B	5403JJ1007A	Condenser Assembly,Wire
142D	5026JJ2001L	Shelf,Net	327A	5006JA3034A	Cap,Drain Tube
142E	5026JJ2001M	Shelf,Net	328B	4J04328A	Damper,Pipe
143E	5027JJ1013H	Shelf Assembly,Refrigerator	329A	5901JJ1005A	Fan Assembly
143F	5027JJ1013S	Shelf Assembly,Refrigerator	329C	ADP36665702	Fan Assembly
145A	4930JJ2003A	Holder,Shelf	332A	AEB36834001	Grille Assembly,Fan
145B	4930JJ2004A	Holder,Shelf	401A	6615JB2005C	Controller Assembly
145C	4975JJ2028C	Guide Assembly,Rail	402A	6600JB3007E	Switch,Push Button
145F	4975JJ2028D	Guide Assembly,Rail	404A	EAU52096201	Motor,DC
147A	5074JJ1005A	Bucket,Dairy	405A	4810JJ0001A	Bracket,Motor
147C	3550JJ1017A	Cover,Bucket	405A	6421JB2002D	Solenoid,Reversing, Valve
151A	3391JJ1038C	Tray Assembly,Vegetable	405B	5040JJ2001A	Damper,Motor Support
151C	4940JJ2010A	KNOB,SHUTTER	405C	5040JA2009B	Damper,Motor Support
154A	MCK49494001	Cover,TV	405F	5040JA2004B	Damper,Motor Support
155B	4980JJ1016A	SUPPORTER,COVER TV	405G	4811JJ2002J	Bracket Assembly,Motor
158A	3550JJ1004A	Cover,Lamp	406B	6600JB1004A	Switch,Push Button
158E	MCK30060901	Cover,Lamp	407A	ADJ36834101	Duct Assembly,Connector
167B	4890JL1002H	Shelf,Glass	409B	6912JK2002C	Lamp,Incandescent
170A	3391JJ2018B	TRAY ASSEMBLY,MEAT	409D	3034JJ1002B	Reflector,Lamp
200A	ADC52734106	Door Assembly,Freezer	410A	6621JK2003B	Drawing,Assembly
201A	ADD36429907	Door Foam Assembly,Freezer	410C	4932JJ2006C	Connector,Tilt
203A	4987JJ1004E	Gasket Assembly,Door	410G	OCZZJB2012K	Capacitor,Electric Appliance Film,Box
207C	ACW36833902	Decor Assembly,Case	411A	6411JK1006L	Power Cord Assembly
212A	MEB42409803	Handle,Refrigerator	412D	6877JK2011A	Drawing,Assembly
212B	MEB42518903	Handle,Freezer	418A	5300JB1100J	Heater,Sheath
212F	4810JJ3019B	Bracket,Handle	420A	4681JB1029J	Motor,DC
212F	4810JJ3019B	Bracket,Handle	500B	6871JB2061B	PCB Assembly,Sub
212G	4140JD1031A	Name Plate	501A	EBR41956101	PCB Assembly
212J	4620JJ3007B	Stopper,Handle	501F	3551JJ1020A	Cover Assembly,PCB
212J	4620JJ3007B	Stopper,Handle	503D	3110JJ1021A	Case,Display
230A	ADC52734306	Door Assembly,Refrigerator(Right)	600A	AEQ36756907	Ice Maker Assembly,Kit
230B	ADC52734206	Door Assembly,Refrigerator(Left)	600B	AKC37000402	Bucket Assembly,Ice
231A	ADD36429807	Door Foam Assembly,Refrigerator	603B	4931JA3005B	Holder Assembly,Bracket
231B	ADD36429702	Door Foam Assembly,Refrigerator	603C	4930JA3091A	Holder,Bracket
233A	4987JJ2003F	Gasket Assembly,Door	603D	4930JA3093A	Holder,Bracket
233B	4987JJ2003H	Gasket Assembly,Door	606A	MCK41991601	Cover,Motor
233C	ACQ36835601	Cover Assembly,Front	610A	3550JJ2020A	Cover,Sensor
233D	ACQ36835602	Cover Assembly,Front	611A	5231JA2006E	Filter Assembly,Water
233E	4930JJ2028B	Holder,Gasket	611B	5230JA2003A	Filter,Head
233F	4930JJ2028A	Holder,Gasket	611C	3550JL1008F	Cover,Filter
233G	4430JJ2005B	Cam,Shaft	611D	3550JJ2028B	Cover,Filter
233H	4430JJ2005A	Cam,Shaft	614A	6421JA3001X	Solenoid,Reversing, Valve
237A	4974JJ2017A	Guide,Pitcher	615A	4838JA2003B	Tank,Water
237C	4974JJ1021A	Guide,Drawer	616A	5210JA3005X	Tube,Plastic
241A	3550JL2006B	Cover,Tray	616D	5210JA3004B	Tube,Plastic
241B	5074JJ1019A	Bucket,Dairy	616H	4932JA3014A	Connector,Tube
241C	5005JJ2021B	Basket Assembly,Door	616J	MCD38280801	Connector,Tube
241D	5005JJ2022A	Basket Assembly,Door	616K	4932JA2003B	Connector,Tube
241G	AAP37000301	Basket Assembly,Door	617A	5210JA3005G	Tube,Plastic
243A	4620JJ3006C	Stopper,Door	617B	4970JA3004G	Spring
243B	4620JJ2009A	Stopper,Door	619A	MJX41869201	Valve,Water
248E	3806JJ1048A	Decor,Tray	619B	3550JJ2024A	Cover,Valve
248F	3806JL2011C	Decor,Tray	623B	5006JJ2003A	Cap,Cover
249C	ACJ32471702	Connector Assembly	623C	4770JA3001A	Band
249D	ACJ32471701	Connector Assembly	625A	3550JA2184A	Cover,Tube
249E	5218JA1010E	Rail,Slide	627A	4930JA3054A	Holder,Pipe
249F	5218JA1010F	Rail,Slide	630A	3581JA1182G	Door Assembly,Freeze Room
249J	ACJ32308804	Connector Assembly	630B	5433JA2071E	Door Foam Assembly,Home Bar
249K	ACJ32308803	Connector Assembly	630C	MDS41996601	Gasket,Door
249L	MCK30136701	Cover,Connector	630E	MCR42600501	Decor,Handle
249M	MCK30136702	Cover,Connector	630F	AEH36582801	Hinge Assembly,Upper
250A	4270JJ3001E	Bar	630G	AEH36582701	Hinge Assembly,Lower
250B	4403JJ3001A	Connector Assembly	630H	MCK42523301	Cover,Home Bar
262E	4350JA3005B	Ring	630J	4987JA3025A	Gasket Assembly,Door
262H	4775JJ2019D	Hinge Assembly,Center	630K	4970JA3044A	Spring
271A	AEH36437001	Hinge Assembly,Upper	630L	4970JA3045A	Spring
271C	AEH36437002	Hinge Assembly,Upper	630M	4860JA3010A	Clamp
275A	5007JA3006R	Cap Assembly,Duct	630N	4860JA3010B	Clamp
276A	4970JA3011C	Spring,Lever	631A	MCK41996401	Cover,Front
276B	4930JA3043A	Holder,Lever	903A	3550J0006C	Cover,Lower
278A	3017JA2008C	Funnel Assembly	903B	4930JJ2021A	Holder,Cover(Lower)
278C	4510JA2006A	Lever,Dispenser	903D	6500JK1003A	Sensor
278D	MDR42523602	Funnel	903E	6500JK1004A	Sensor
279A	ACQ37160703	Cover Assembly,Dispenser	B01	1STZJA3004F	Screw,Customized
281A	ACQ36833804	Cover Assembly,Hinge	B04	1STZJA3001B	Screw,Customized
281D	3550JJ2043A	Cover,Hinge	S01	1SZZJJ3010A	Screw,Customized
281G	3550JJ2044A	Cover,Hinge	S24	1SZZJA3011B	Screw,Customized
281H	4775JJ2011B	Hinge Assembly,Lower	S27	4J01424C	Screw,Customized
282B	4775JJ2019C	Hinge Assembly,Center	S31	4J01425D	Screw,Customized
282E	ACQ36833803	Cover Assembly,Hinge	S32	3J05696W	Screw,Customized
282F	3806JL2006D	Decor,Duct	S38	4J00415D	Screw,Customized

Loc No	Part No.	Description	Loc No	Part No.	Description
103A	3650JJ2003H	Handle,Rear	304A	3551JJ2008B	Cover Assembly,Machinery(Rear)
103B	3650JJ2003D	Handle,Rear	305B	4580JJ3001A	Roller
103C	3551JJ1015H	Cover Assembly,Lower	305B	4580JJ3001A	Roller
103E	5218JJ3001A	Rail,Slide	305C	4J04238A	Pin,Common
103E	5218JJ3001A	Rail,Slide	305C	4J04238A	Pin,Common
104E	4931JJ3002A	Holder Assembly,Gasket	305D	4580JA3042A	Roller
105A	5251JA3003B	Tube Assembly,Drain	307A	TCA31748001	Compressor,Set Assembly
105F	5070JJ3002A	Skirt,Lower	308A	6748C-0004D	Thermistor Assembly,PTC
106A	4779JA2003A	Leg Assembly,Adjust	309A	6750C-0004R	Overload Protect
120B	5209JJ1002C	Duct Assembly,Multi	310A	3550JA2059A	Cover,PTC
125D	4930JJ3007A	Holder,Bracket	312A	5040JA3031A	Damper,Compressor
128A	4975JJ2002A	Guide Assembly,Rail	313A	5040JJ3007A	Damper
128B	4975JJ2002B	Guide Assembly,Rail	313A	5040JJ3007A	Damper
128E	4930JJ1025A	Holder,Rail	314A	4620JA3009A	Stopper,Compressor
128F	4930JJ1025B	Holder,Rail	315A	3103JJ1001J	Base Assembly,Compressor
131A	MKK42003201	Bucket,Ice	317A	5851JJ2002F	Drier Assembly
136A	3391JJ1011B	Tray Assembly,Drawer	318A	4930JA3034A	Holder,Drier
136B	MJS42003601	Tray,Drawer	319A	3390JJ0004A	Tray,Drip
140D	MHL38615403	Shelf,Net	319C	MEA41997401	Guide,Fan
140E	MHL38615404	Shelf,Net	319E	4810JJ2005A	Bracket,Motor
142B	5027JJ1039A	Shelf Assembly,Refrigerator	323B	5403JJ1007A	Condenser Assembly,Wire
142B	5027JJ1039A	Shelf Assembly,Refrigerator	327A	5006JA3034A	Cap,Drain Tube
142D	5026JJ2001L	Shelf,Net	328B	4J04328A	Damper,Pipe
142E	5026JJ2001M	Shelf,Net	329A	5901JJ1005A	Fan Assembly
143E	5027JJ1013H	Shelf Assembly,Refrigerator	329C	ADP36665702	Fan Assembly
143F	5027JJ1013S	Shelf Assembly,Refrigerator	332A	AEB36834001	Grille Assembly,Fan
145A	4930JJ2003A	Holder,Shelf	401A	6615JB2005C	Controller Assembly
145B	4930JJ2004A	Holder,Shelf	402A	6600JB3007B	Switch,Push Button
145C	4975JJ2028C	Guide Assembly,Rail	402A	6600JB3007B	Switch,Push Button
145F	4975JJ2028D	Guide Assembly,Rail	404A	EAU52096201	Motor,DC
146A	5004JJ1071A	BASKET,DOOR	405A	4810JJ0001A	Bracket,Motor
147A	5074JJ1005A	Bucket,Dairy	405A	6421JB2002D	Solenoid,Reversing,Valve
147C	3550JJ1017A	Cover,Bucket	405B	5040JJ2001A	Damper,Motor Support
151A	3391JJ1038C	Tray Assembly,Vegetable	405C	5040JA2009B	Damper,Motor Support
151C	4940JJ2010A	KNOB,SHUTTER	405F	5040JA2004B	Damper,Motor Support
154A	MCK49494001	Cover,TV	405G	4811JJ2002J	Bracket Assembly,Motor
155B	4980JJ1016A	SUPPORTER,COVER TV	406B	6600JB1010A	Switch,Push Button
158A	3550JJ1104A	Cover,Lamp	407A	ADJ36834101	Duct Assembly,Connector
158E	MCK30060901	Cover,Lamp	409B	6912JK2002C	Lamp,Incandescent
167B	4890JJ1002H	Shelf,Glass	409D	3034JJ1002B	Reflector,Lamp
170A	3391JJ2018B	TRAY ASSEMBLY,MEAT	410A	6621JK2003B	Harness Assembly
200A	ADC52734109	Door Assembly,Freezer	410C	4932JJ2006C	Connector,Tilt
201A	ADD36429910	Door Foam Assembly,Freezer	410G	OCZJB2012K	Capacitor,Electric Appliance Film,Box
203A	4987JJ1004Z	Gasket Assembly,Door	411A	6411JK1006L	Power Cord Assembly
207C	ACW36833904	Decor Assembly,Case	412D	6877JK2011A	Harness Assembly
212A	AED37133501	Handle Assembly,Freezer	418A	5300JB1100J	Heater,Sheath
212G	4140JD1031A	Name Plate	420A	4681JB1029J	Motor,DC
212J	4620JJ3007B	Stopper,Handle	500B	6871JB2061B	PCB Assembly,Sub
212J	4620JJ3007B	Stopper,Handle	501A	EBR41956101	PCB Assembly
230A	ADC52734309	Door Assembly,Refrigerator(Right)	501F	3551JJ1020A	Cover Assembly,PCB
230B	ADC52734209	Door Assembly,Refrigerator(Left)	503D	3110JJ1021A	Case,Display
231A	ADD36429812	Door Foam Assembly,Refrigerator	600A	AEQ36756907	Ice Maker Assembly,Kit
231B	ADD36429705	Door Foam Assembly,Refrigerator	600B	AKC37000402	Bucket Assembly,Ice
233A	4987JJ2003N	Gasket Assembly,Door	603B	4931JA3005B	Holder Assembly,Bracket
233B	4987JJ2003P	Gasket Assembly,Door	603C	4930JA3091A	Holder,Bracket
233C	ACQ36835601	Cover Assembly,Front	603C	4930JA3091A	Holder,Bracket
233D	ACQ36835602	Cover Assembly,Front	603C	4930JA3091A	Holder,Bracket
233E	4930JJ2028B	Holder,Gasket	603D	4930JA3093A	Holder,Bracket
233F	4930JJ2028A	Holder,Gasket	606A	MCK41991601	Cover,Motor
233G	4430JJ2005B	Cam,Shaft	610A	3550JJ2020A	Cover,Sensor
233H	4430JJ2005A	Cam,Shaft	611A	5231JA2006E	Filter Assembly,Water
237A	4974JJ2017A	Guide,Pitcher	611B	5230JA2003A	Filter,Head
237C	4974JJ1021A	Guide,Drawer	611C	3550JL1008F	Cover,Filter
241A	3550JL2006B	Cover,Tray	611D	3550JJ2028B	Cover,Filter
241B	5074JJ1019A	Bucket,Dairy	614A	6421JA3001X	Solenoid,Reversing,Valve
241C	5005JJ2021B	Basket Assembly,Door	615A	4838JA2003B	Tank,Water
241D	5005JJ2022A	Basket Assembly,Door	616A	5210JA3005X	Tube,Plastic
241G	AAP37000301	Basket Assembly,Door	616D	5210JA3004B	Tube,Plastic
243A	4620JJ3006D	Stopper,Door	616H	4932JA3014A	Connector,Tube
243A	4620JJ3006D	Stopper,Door	616J	MCD38280801	Connector,Tube
243B	4620JJ2009A	Stopper,Door	616K	4932JA2003B	Connector,Tube
243B	4620JJ2009A	Stopper,Door	617A	5210JA3005G	Tube,Plastic
244A	AED37133301	Handle Assembly,Refrigerator	617B	4970JA3004G	Spring
248E	3806JJ1048A	Decor,Tray	619A	MJX41869201	Valve,Water
248F	3806JL2011C	Decor,Tray	619B	3550JJ2024A	Cover,Valve
249C	ACJ32471702	Connector Assembly	623B	5006JJ2003A	Cap,Cover
249D	ACJ32471701	Connector Assembly	623C	4770JA3001A	Band
249E	5218JA1010E	Rail,Slide	625A	3550JA2184A	Cover,Tube
249F	5218JA1010F	Rail,Slide	627A	4930JA3054A	Holder,Pipe
249J	ACJ32308804	Connector Assembly	630A	3581JA1182G	Door Assembly,Freeze Room
249K	ACJ32308803	Connector Assembly	630B	5433JA2071E	Door Foam Assembly,Home Bar
249L	MCK30136701	Cover,Connector	630C	MDS41996601	Gasket,Door
249M	MCK30136702	Cover,Connector	630E	MCR42600501	Decor,Handle
250A	4270JJ3001E	Bar	630F	AEH36582801	Hinge Assembly,Upper
250B	4403JJ3001A	Connector Assembly	630G	AEH36582701	Hinge Assembly,Lower
250B	4403JJ3001A	Connector Assembly	630H	MCK42523301	Cover,Home Bar
262E	4350JA3005B	Ring	630J	4987JA3025A	Gasket Assembly,Door
262H	4775JJ2019F	Hinge Assembly,Center	630K	4970JA3044A	Spring
271A	AEH36437001	Hinge Assembly,Upper	630L	4970JA3045A	Spring
271C	AEH36437002	Hinge Assembly,Upper	630M	4860JA3010A	Clamp
275A	5007JA3006R	Cap Assembly,Duct	630N	4860JA3010B	Clamp
276A	4970JA3011C	Spring,Lever	631A	MCK41996401	Cover,Front
276B	4930JA3043A	Holder,Lever	903A	3550JJ0006D	Cover,Lower
278A	3017JA2008B	Funnel Assembly	903B	4930JJ2021A	Holder,Cover(Lower)
278C	4510JA2006A	Lever,Dispenser	903D	6500JK1003A	Sensor
278D	MDR42523603	Funnel	903E	6500JK1004A	Sensor
279A	ACQ37160701	Cover Assembly,Dispenser	B01	1STZJA3004F	Screw,Customized
281A	ACQ36833808	Cover Assembly,Hinge	B04	1STZJA3001B	Screw,Customized
281D	3550JJ2043A	Cover,Hinge	S01	1SZZJ3010A	Screw,Customized
281G	3550JJ2044A	Cover,Hinge	S24	1SZZJA3011B	Screw,Customized
281H	4775JJ2011B	Hinge Assembly,Lower	S24	1SZZJA3011B	Screw,Customized
282B	4775JJ2019E	Hinge Assembly,Center	S27	4J01424C	Screw,Customized
282E	ACQ36833807	Cover Assembly,Hinge	S27	4J01424C	Screw,Customized
282F	3806JL2006D	Decor,Duct	S31	4J00415D	Screw,Customized
286A	4984JJ3003A	BUSH	S32	4J01425B	Screw,Customized
286A	4984JJ3003A	BUSH	S38	4J00415D	Screw,Customized
301A	5421JJ1001B	Evaporator Assembly	S38	4J00415D	Screw,Customized

Loc No.	Part No.	Description	Loc No.	Part No.	Description
103A	3650JJ2003M	Handle,Rear	304A	3551JJ2008B	Cover Assembly,Machinery(Rear)
103B	3650JJ2003L	Handle,Rear	305B	4580JJ3001A	Roller
103C	3551JJ1015F	Cover Assembly,Lower	305B	4580JJ3001A	Roller
103E	5218JJ3001A	Rail,Slide	305C	4J04238A	Pin,Common
103E	5218JJ3001A	Rail,Slide	305C	4J04238A	Pin,Common
104E	4931JJ3002A	Holder Assembly,Gasket	305D	4580JA3042A	Roller
105A	5251JA3003B	Tube Assembly,Drain	307A	TCA31748001	Compressor,Set Assembly
105F	5070JJ3002A	Skirt,Lower	308A	6748C-0004D	Thermistor Assembly,PTC
106A	4779JA2003A	Leg Assembly,Adjust	309A	6750C-0004R	Overload Protect
120B	5209JJ1002C	Duct Assembly,Multi	310A	3550JA2059A	Cover,PTC
125D	4930JJ3007A	Holder,Bracket	312A	5040JA3031A	Damper,Compressor
128A	4975JJ2002A	Guide Assembly,Rail	313A	5040JJ3007A	Damper
128B	4975JJ2002B	Guide Assembly,Rail	313A	5040JJ3007A	Damper
128E	4930JJ1025A	Holder,Rail	314A	4620JA3009A	Stopper,Compressor
128F	4930JJ1025B	Holder,Rail	315A	3103JJ1001J	Base Assembly,Compressor
131A	MK42003201	Bucket,Ice	317A	5851JJ2002F	Drier Assembly
136A	3391JJ1011B	Tray Assembly,Drawer	318A	4930JA3034A	Holder,Drier
136B	MJS42003601	Tray,Drawer	319A	3390JJ0004A	Tray,Drip
140D	MHL38615403	Shelf,Net	319C	MEA41997401	Guide,Fan
140E	MHL38615404	Shelf,Net	319E	4810JJ2005A	Bracket,Motor
142B	5027JJ1039A	Shelf Assembly,Refrigerator	323B	5403JJ1007A	Condenser Assembly,Wire
142B	5027JJ1039A	Shelf Assembly,Refrigerator	327A	5006JA3034A	Cap,Drain Tube
142D	5026JJ2001L	Shelf,Net	328B	4J04328A	Damper,Pipe
142E	5026JJ2001M	Shelf,Net	329A	5901JJ1005A	Fan Assembly
143E	5027JJ1013H	Shelf Assembly,Refrigerator	329C	ADP36665702	Fan Assembly
143F	5027JJ1013S	Shelf Assembly,Refrigerator	332A	AEB36834001	Grille Assembly,Fan
145A	4930JJ2003A	Holder,Shelf	401A	6615JB2005C	Controller Assembly
145B	4930JJ2004A	Holder,Shelf	402A	6600JB3007E	Switch,Push Button
145C	4975JJ2028C	Guide Assembly,Rail	402A	6600JB3007E	Switch,Push Button
145F	4975JJ2028D	Guide Assembly,Rail	404A	EAU52096201	Motor,DC
146A	5004JJ1071A	BASKET,DOOR	405A	4810JJ0001A	Bracket,Motor
147A	5074JJ1005A	Bucket,Dairy	405A	6421JB2002D	Solenoid,Reversing,Valve
147C	3550JJ1017A	Cover,Bucket	405B	5040JJ2001A	Damper,Motor Support
151A	3391JJ1038C	Tray Assembly,Vegetable	405C	5040JA2009B	Damper,Motor Support
151C	4940JJ2010A	KNOB,SHUTTER	405F	5040JA2004B	Damper,Motor Support
154A	MCK49494001	Cover,TV	405G	4811JJ2002J	Bracket Assembly,Motor
155B	4980JJ1016A	SUPPORTER,COVER TV	406B	6600JB1010A	Switch,Push Button
158A	3550JJ1104A	Cover,Lamp	407A	ADJ36834101	Duct Assembly,Connector
158E	MCK30060901	Cover,Lamp	409B	6912JK2002C	Lamp,Incandescent
167B	4890JL1002H	Shelf,Glass	409D	3034JJ1002B	Reflector,Lamp
170A	3391JJ2018B	TRAY ASSEMBLY,MEAT	410A	6621JK2003B	Harness Assembly
200A	ADC52734106	Door Assembly,Freezer	410C	4932JJ2006C	Connector,Tilt
201A	ADD36429907	Door Foam Assembly,Freezer	410G	OCZZJB2012K	Capacitor,Electric Appliance Film,Box
203A	4987JJ1004E	Gasket Assembly,Door	411A	6411JK1006L	Power Cord Assembly
207C	ACW36833902	Decor Assembly,Case	412D	6877JK2011A	Harness Assembly
212A	AED37133502	Handle Assembly,Freezer	418A	5300JB1100J	Heater,Sheath
212G	4140JD1031A	Name Plate	420A	4681JB1029J	Motor,DC
212J	4620JJ3007B	Stopper,Handle	500B	6871JB2061B	PCB Assembly,Sub
212J	4620JJ3007B	Stopper,Handle	501A	EBR41956101	PCB Assembly
230A	ADC52734306	Door Assembly,Refrigerator(Right)	501F	3551JJ1020A	Cover Assembly,PCB
230B	ADC52734206	Door Assembly,Refrigerator(Left)	503D	3110JJ1021A	Case,Display
231A	ADD36429807	Door Foam Assembly,Refrigerator	600A	AEQ36756907	Ice Maker Assembly,Kit
231B	ADD36429702	Door Foam Assembly,Refrigerator	600B	AKC37000402	Bucket Assembly,Ice
233A	4987JJ2003F	Gasket Assembly,Door	603B	4931JA3005B	Holder Assembly,Bracket
233B	4987JJ2003H	Gasket Assembly,Door	603C	4930JA3091A	Holder,Bracket
233C	ACQ36835601	Cover Assembly,Front	603C	4930JA3091A	Holder,Bracket
233D	ACQ36835602	Cover Assembly,Front	603C	4930JA3091A	Holder,Bracket
233E	4930JJ2028B	Holder,Gasket	603D	4930JA3093A	Holder,Bracket
233F	4930JJ2028A	Holder,Gasket	606A	MCK41991601	Cover,Motor
233G	4430JJ2005B	Cam,Shaft	610A	3550JJ2020A	Cover,Sensor
233H	4430JJ2005A	Cam,Shaft	611A	5231JA2006E	Filter Assembly,Water
237A	4974JJ2017A	Guide,Pitcher	611B	5230JA2003A	Filter,Head
237C	4974JJ1021A	Guide,Drawer	611C	3550JL1008F	Cover,Filter
241A	3550JL2006B	Cover,Tray	611D	3550JJ2028B	Cover,Filter
241B	5074JJ1019A	Bucket,Dairy	614A	6421JA3001X	Solenoid,Reversing,Valve
241C	5005JJ2021B	Basket Assembly,Door	615A	4838JA2003B	Tank,Water
241D	5005JJ2022A	Basket Assembly,Door	616A	5210JA3005X	Tube,Plastic
241G	AAP37000301	Basket Assembly,Door	616D	5210JA3004B	Tube,Plastic
243A	4620JJ3006C	Stopper,Door	616H	4932JA3014A	Connector,Tube
243A	4620JJ3006C	Stopper,Door	616J	MCD38280801	Connector,Tube
243B	4620JJ2009A	Stopper,Door	616K	4932JA2003B	Connector,Tube
243B	4620JJ2009A	Stopper,Door	617A	5210JA3005G	Tube,Plastic
244A	AED37133302	Handle Assembly,Refrigerator	617B	4970JA3004G	Spring
248E	3806JJ1048A	Decor,Tray	619A	MJX41869201	Valve,Water
248F	3806JL2011C	Decor,Tray	619B	3550JJ2024A	Cover,Valve
249C	ACJ32471702	Connector Assembly	623B	5006JJ2003A	Cap,Cover
249D	ACJ32471701	Connector Assembly	623C	4770JA3001A	Band
249E	5218JA1010E	Rail,Slide	625A	3550JA2184A	Cover,Tube
249F	5218JA1010F	Rail,Slide	627A	4930JA3054A	Holder,Pipe
249J	ACJ32308804	Connector Assembly	630A	3581JA1182G	Door Assembly,Freeze Room
249K	ACJ32308803	Connector Assembly	630B	5433JA2071E	Door Foam Assembly,Home Bar
249L	MCK30136701	Cover,Connector	630C	MDS41996601	Gasket,Door
249M	MCK30136702	Cover,Connector	630E	MCR42600501	Decor,Handle
250A	4270JJ3001E	Bar	630F	AEH36582801	Hinge Assembly,Upper
250B	4403JJ3001A	Connector Assembly	630G	AEH36582701	Hinge Assembly,Lower
250B	4403JJ3001A	Connector Assembly	630H	MCK42523301	Cover,Home Bar
262E	4350JA3005B	Ring	630J	4987JA3025A	Gasket Assembly,Door
262H	4775JJ2019D	Hinge Assembly,Center	630K	4970JA3044A	Spring
271A	AEH36437001	Hinge Assembly,Upper	630L	4970JA3045A	Spring
271C	AEH36437002	Hinge Assembly,Upper	630M	4860JA3010A	Clamp
275A	5007JA3006R	Cap Assembly,Duct	630N	4860JA3010B	Clamp
276A	4970JA3011C	Spring,Lever	631A	MCK41996401	Cover,Front
276B	4930JA3043A	Holder,Lever	903A	3550JJ0006C	Cover,Lower
278A	3017JA2008C	Funnel Assembly	903B	4930JJ2021A	Holder,Cover(Lower)
278C	4510JA2006A	Lever,Dispenser	903D	6500JK1003A	Sensor
278D	MDR42523602	Funnel	903E	6500JK1004A	Sensor
279A	ACQ37160703	Cover Assembly,Dispenser	B01	1STZJA3004F	Screw,Customized
281A	ACQ36833804	Cover Assembly,Hinge	B04	1STZJA3001B	Screw,Customized
281D	3550JJ2043A	Cover,Hinge	S01	1SZZJA3010A	Screw,Customized
281G	3550JJ2044A	Cover,Hinge	S24	1SZZJA3011B	Screw,Customized
281H	4775JJ2011B	Hinge Assembly,Lower	S24	1SZZJA3011B	Screw,Customized
282B	4775JJ2019C	Hinge Assembly,Center	S27	4J01424C	Screw,Customized
282E	ACQ36833803	Cover Assembly,Hinge	S27	4J01424C	Screw,Customized
282F	3806JL2006D	Decor,Duct	S31	4J00415D	Screw,Customized
286A	4984JJ3003A	BUSH	S32	4J01425B	Screw,Customized
286A	4984JJ3003A	BUSH	S38	4J00415D	Screw,Customized
301A	5421JJ1001B	Evaporator Assembly	S38	4J00415D	Screw,Customized



*'You Can Count on me . . .
to Work Safely.'*