

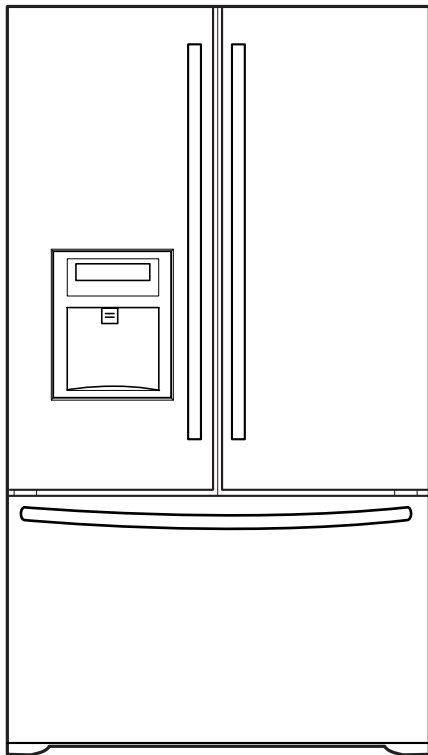

REFRIGERATOR SERVICE MANUAL

CAUTION
BEFORE SERVICING THE UNIT,
READ THE SAFETY PRECAUTIONS IN THIS MANUAL.



Model #s:

795.78502800
795.78503800
795.78506800
795.78509800
795.78512800
795.78513800
795.78516800
795.78519800

CONTENTS

SAFETY PRECAUTIONS	2
1. SPECIFICATIONS	3-4
2. PARTS IDENTIFICATION	5
3. DISASSEMBLY	6-14
REMOVING AND REPLACING REFRIGERATOR DOORS	6
DOOR	7-8
TO REMOVE THE DISPENSER	8
DOOR ALIGNMENT	8
FAN AND FAN MOTOR(Evaporator)	8
ICE FAN SCROLL ASSEMBLY REPLACEMENT	9
DEFROST CONTROL ASSEMBLY	9
LAMP	9
CONTROL BOX-REFRIGERATOR	9
MULTI DUCT	10
MAIN PWB, DISPLAY PWB REPLACEMENT, FUNNEL REPLACEMENT.....	10
SUB PWB FOR DISPENSER, DUCT DOOR REPLACEMENT, ICE CORNER DOOR REPLACEMENT, ICE MAKER ASSEMBLY	11
AUGER MOTOR COVER, AUGER MOTOR REPLACEMENT	12
DOOR ICE BIN	13
HOW TO REMOVE AND REINSTALL THE PULLOUT DRAWER	14-15
WATER VALVE DISASSEMBLY METHOD.....	16
FAN AND FAN MOTOR DISASSEMBLY METHOD	16
PULL OUT DRAWER	17
4. ADJUSTMENT	18-19
COMPRESSOR	18
PTC-STARTER	18
OLP(OVERLOAD PROTECTOR).....	19
TO REMOVE THE COVER PTC	19
5. CIRCUIT DIAGRAM	20
6. TROUBLESHOOTING	21-25
COMPRESSOR AND ELECTRIC COMPONENTS	21
OTHER ELECTRICAL COMPONENTS	22
SERVICE DIAGNOSIS CHART	23
REFRIGERATION CYCLE	24-25
7. OPERATION PRINCIPLE & REPAIR METHOD OF ICEMAKER	26-28
8. DESCRIPTION OF FUNCTION, CIRCUITS & ERROR CODES	29-43

SAFETY PRECAUTIONS

Please read the following instructions before servicing your refrigerator.

1. Unplug the power before handling any electrical components.
2. Check the rated current, voltage, and capacity.
3. Take caution not to get water near any electrical components.
4. Use exact replacement parts.
5. Remove any objects from the top prior to tilting the product.

1. SPECIFICATIONS

1-1 DISCONNECT POWER CORD BEFORE SERVICING IMPORTANT – RECONNECT ALL GROUNDING DEVICES

All parts of this appliance capable of conducting electrical current are grounded. If grounding wires, screws, straps, clips, nuts or washers used to complete a path to ground are removed for service, they must be returned to their original position and properly fastened.

1-2 IMPORTANT NOTICE

This information is intended for use by individuals possessing adequate backgrounds of electrical, electronic and mechanical experience. Any attempt to repair a major appliance may result in personal injury and property damage. The manufacturer or seller cannot be responsible for the interpretation of this information, nor can it assume any liability in connection with its use.

1-3 ELECTRICAL SPECIFICATIONS

Temperature Control (Freezer Compartment) ...-6°F to +8°F
 Defrost Control.....Total Comp Running Time: 7 hrs~50 hrs
 Defrost Thermostat46°F
 Electrical Rating : 115VAC, 60Hz.....7.2 A
 Maximum Current Leakage.....0.5 mA
 Maximum Ground Path Resistance0.14 Ohms
 Energy Consumption25 cu.ft. 547 kWh/yr (Energy Star)

1-4 NO LOAD PERFORMANCE CONTROL POSITION: MID/MID

And Ambient of:70°F.....90°F
 Fresh Food, °F33°F to 41°F.....33°F to 41°F
 Frozen Food, °F-4°F to +4°F.....-4°F to +4°F
 Percent Running Time35%-45%.....50°F-70°F

1-5 REFRIGERATION SYSTEM

Minimum Compressor Capacity Vacuum 21 MIN.
 Minimum Equalized Pressure
 @ 70°F 49 PSIG
 @ 90°F 56 PSIG
 Refrigerant R134a 4.76 oz.
 Compressor 956 BTU/hr

1-6 INSTALLATION

Clearance must be provided at top, sides and rear of the refrigerator for air circulation.

AT TOP 2 in
 AT SIDES 1 in
 AT REAR 1 in

1-7 REPLACEMENT PARTS

Relay.....	6748C-0004D
Overload.....	6750C-0004R
Defrost Thermostat.....	6615JB2005H
Defrost Heater.....	5300JK1005D
Evaporator Fan Motor.....	4681JK1004E
Capacitor (Running).....	0CKZZJB2012K (0CKZZJB2014B) (0CKZZJB2012H)
Compressor (Hi-Side).....	TCA31748001
Evaporator (Lo-Side).....	5421JJ1007A
Condenser.....	ACG366533801
Dryer.....	5851JA2002P
Condenser Fan Motor.....	4681JB1029D
Temperature Control.....	ACQ37160701(STS/TTM) ACQ37160702(SW) ACQ37160703(WB)
Main Control.....	EBR41956403
Ice Fan Motor.....	4681JB1029E
*OPTIONAL	

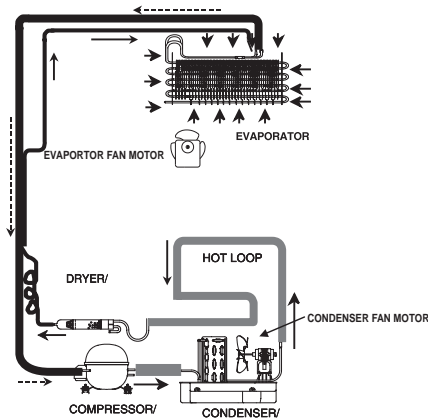

AIR FLOW

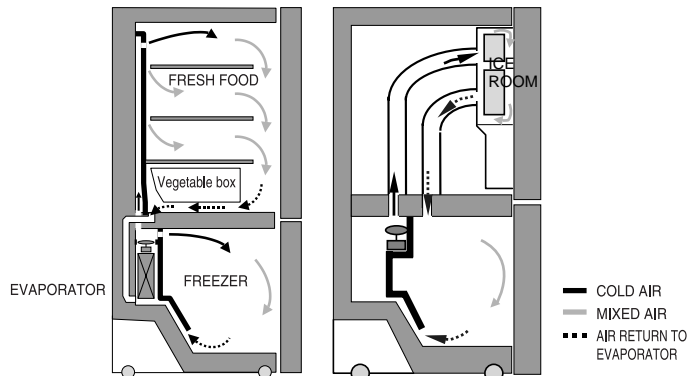

1-8 AIR FLOW / CIRCULATION D'AIR

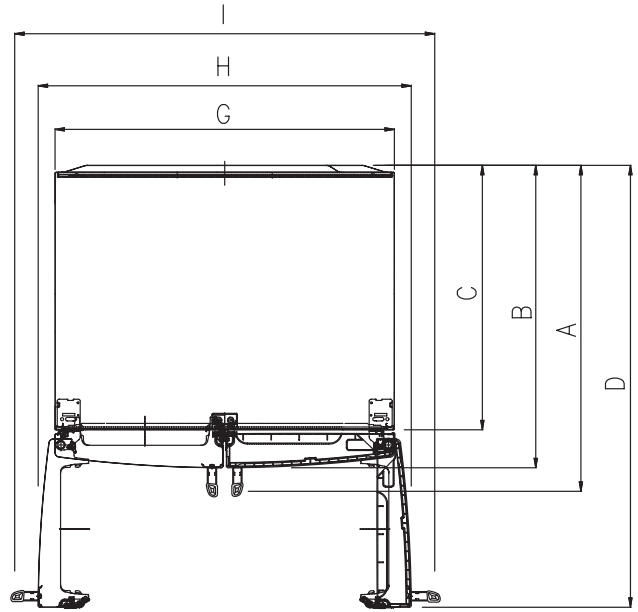
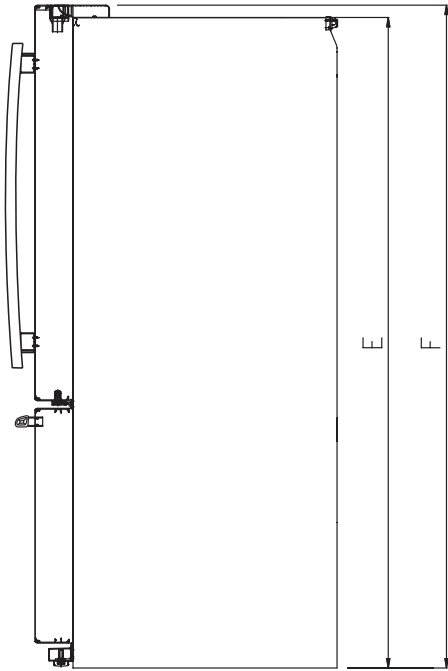

Description		795.785**
Depth w/ Handles	A	34 1/4 in
Depth w/ Handles	B	31 3/4 in
Depth w/ o Door	C	27 7/8 in
Depth (Total with Door Open)	D	46 1/2 in
Height to Top of Case	E	68 3/8 in
Height to Top of Door Hinge	F	69 3/4 in
Width	G	35 3/4 in
Width (door open 90 deg. w/o handle)	H	39 1/4 in

2. PARTS IDENTIFICATION

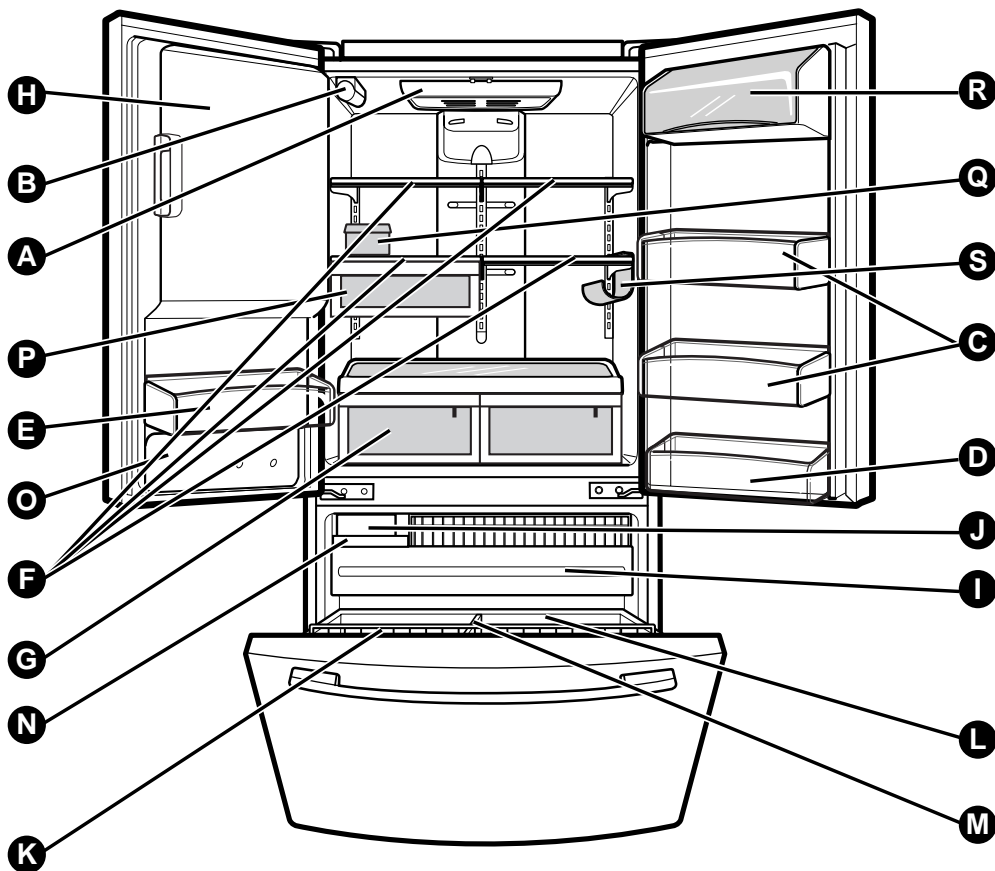

Use this page to become more familiar with the parts and features. Page references are included for your convenience.

NOTE: This guide covers several different models. The refrigerator you have purchased may have some or all of the items listed below. The locations of the features shown below may not match your model.

- | | |
|---|--|
| A Refrigerator Light | K Tilt-Out Door Basket |
| B Filter (Inside) | L Durabase |
| C Modular Door Bins | M Divider |
| D Fixed door bin | N Ice Bin |
| E Tilting door bin | O Water Tank Cover |
| F Refrigerator Shelves | P Snack Pan |
| G Crisper | Q Egg Box |
| H Ice Room
(Ice Maker and Ice Bucket) | R Dairy Bin |
| I Pull out Drawer | S Bottle Holder
(795.7851* Model only) |
| J Turbo Motor | |

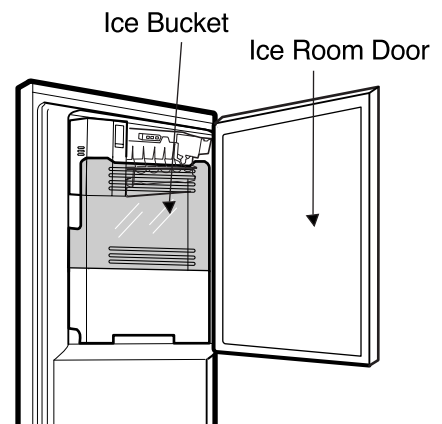

3. DISASSEMBLY

3-1 REMOVING AND REPLACING REFRIGERATOR DOORS

To remove the left refrigerator door:

Pull the water tube out of the fitting while pressing the release ring on the fitting.

When you pull out the tube, first you have to push the collet by opposite direction of arrow in the upper picture and tube pull out by direction of arrow.

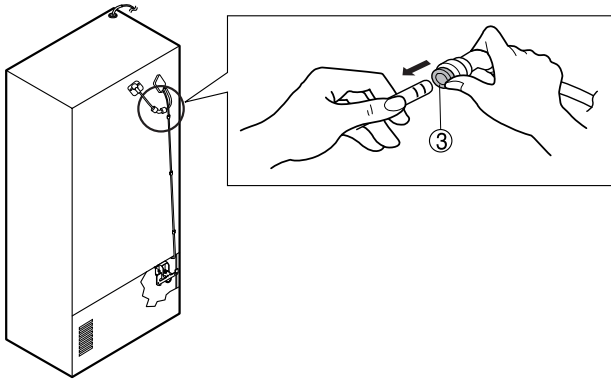

CAUTION : Before you begin, remove food and bins from the doors.

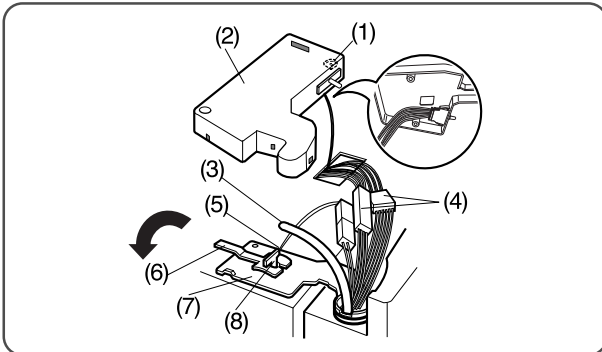

- Open the door. Remove the top hinge cover screw (1).
- Use a flat-head screwdriver to pry back the hooks (not shown) on the front underside of the cover (2). Lift up the cover.
- Remove the cover. Pull out the tube (3).
- Disconnect all the wire harnesses (4).
- Remove the grounding screw(5)
- Rotate hinge lever (6) counterclockwise and remove. Lift the top hinge (7) free of the hinge lever latch (8).

IMPORTANT:When lifting the hinge free of the latch, be careful that the door does not fall forward.

- Lift the door from the middle hinge pin and remove the door.
- Place the door, inside facing up, on a nonscratching surface.

To remove the right refrigerator door:

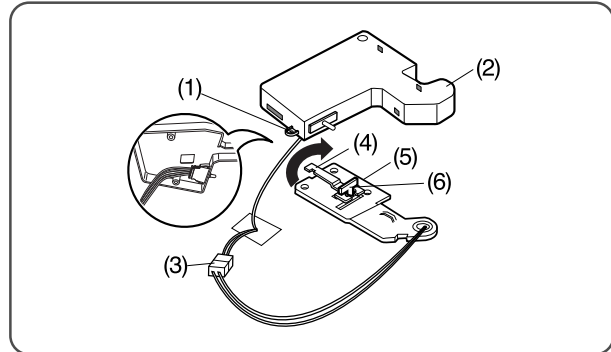

- Open the door. Remove the top hinge cover screw (1). Lift up the cover (2).
- Remove the cover.
- Disconnect the wire harness (3).
- Rotate the hinge lever (4) clockwise and remove. Lift the top hinge (5) free of the hinge lever latch (6).

IMPORTANT: When lifting the hinge free of the latch, be careful that the door does not fall forward.

WARNING

Explosion Hazard

- Disconnect electrical supply to the refrigerator before installing. Failure to do so could result in death or serious injury.
- Do not put hands or feet or other objects into the air vents, base grille, or bottom of the refrigerator. You may be injured or receive an electrical shock.
- Be careful when you work with the hinge, base grille, and stopper. You may be injured.

3-2 DOOR

● Door Gasket Removal

1. Remove door frame cover

Starting at top of cover and working down, snap cover out and away from door.

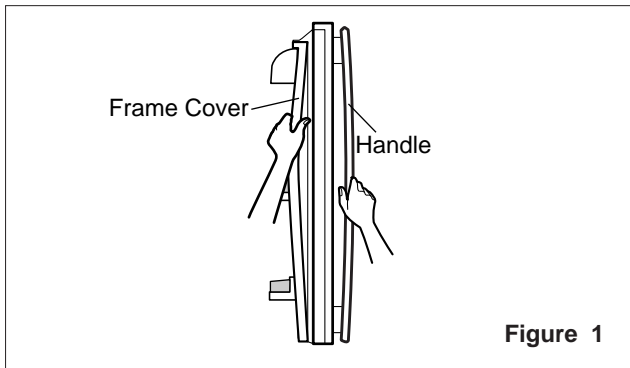

2. Remove gasket bracket clips

There are two clips on each door. Start bracket removal near one of the middle clips.

- 1) Pull gasket back to expose gasket bracket clip and door frame.
- 2) Insert a flat tip screwdriver into seam between gasket bracket and door frame and pry back until clips snap out.
- 3) Continue prying back along seam until all clips snap out.

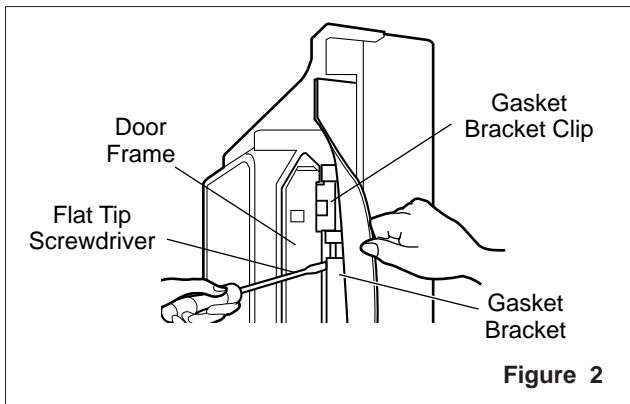

3. Remove gasket

Pull gasket free from gasket channel on the three remaining sides of door.

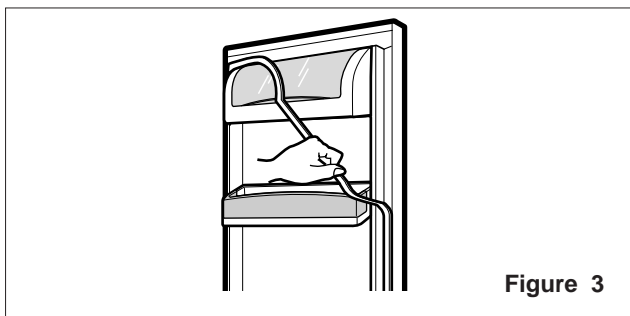

● Door Gasket Replacement

1. Insert gasket bracket clips

- 1) Insert gasket bracket edge beneath door frame edge.
- 2) Turn upper gasket bracket spring so that the spring ends are in the door channel.
- 3) Push in clip until you hear it snap securely into place.

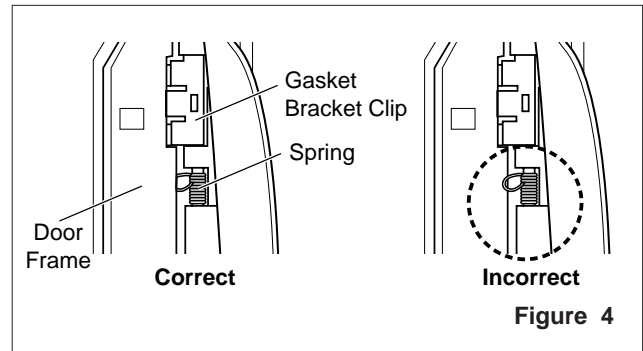

- 4) Push in remaining clip until you hear it snap securely into place.

Note: Make sure that no part of gasket bracket edge protrudes from beneath door frame edge.

2. Insert gasket into channel

- 1) Snap gasket assembly into the door bracket.

<Inserting the Gasket Assembly into the Bracket Door>

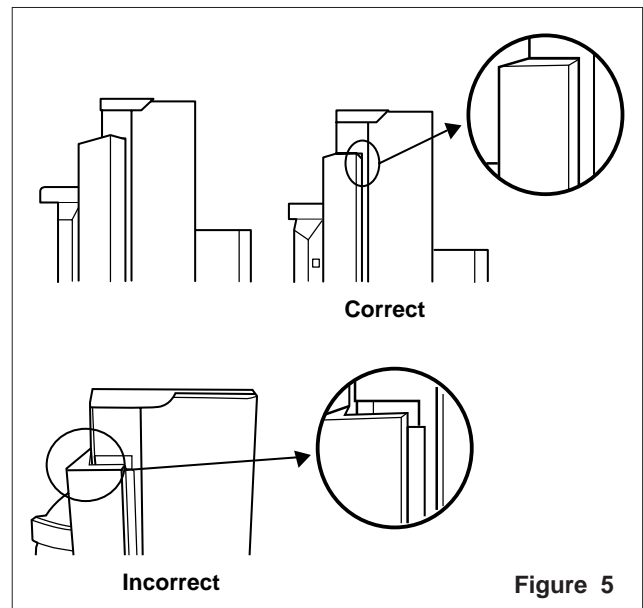

- 2) Press gasket into channels on the three remaining sides of door.

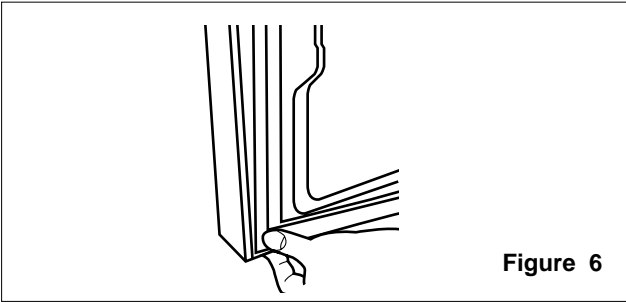

Figure 6

3. Replace door frame cover

Starting at top of cover and working down, snap cover back into door.

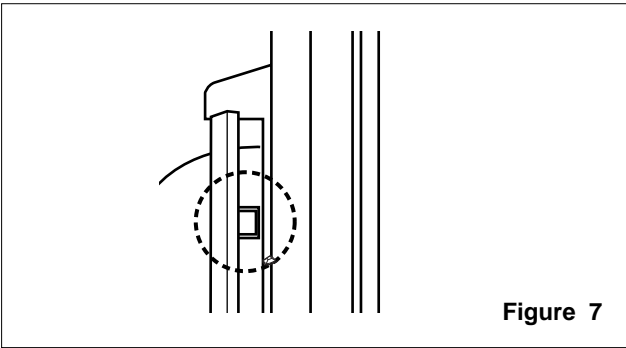

Figure 7

3-3 DOOR ALIGNMENT

If the space between your doors is uneven, follow the instructions below to align the doors:

1. With one hand, lift up the door you want to raise at middle hinge.
2. With other hand, use pliers to insert snap ring as shown.
3. Insert additional snap rings until the doors are aligned. (Three snap rings are provided with unit.)

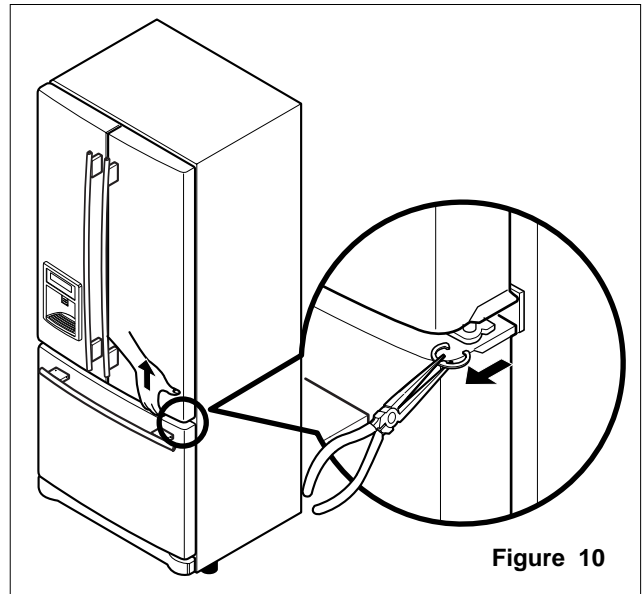

Figure 10

3-4 FAN AND FAN MOTOR(EVAPORATOR)

1. Remove the freezer shelf. (If your refrigerator has an icemaker, remove the icemaker first)
2. Remove the plastic guide for slides on left side by unscrewing phillips head screws.
3. Remove the grille by removing one screw and pulling the grille forward.
4. Remove the Fan Motor assembly by loosening 2 screws and disassembling the shroud.
5. Pull out the fan and separate the Fan Motor and Bracket.

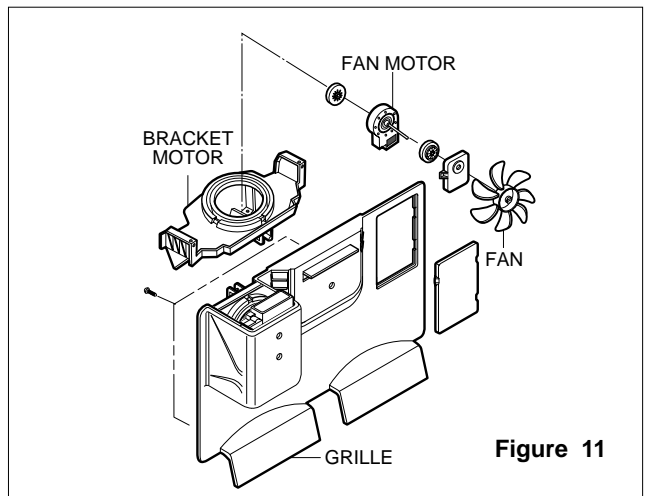

Figure 11

* Ice Fan Scroll Assembly Replacement

- 1) Remove the plastic guide for slides on left side by unscrewing phillips head screws.
- 2) Pull the grille forward as shown in the second picture.
- 3) Disconnect wire harness of the grille
- 4) Remove the scroll assembly by loosening 2 screws



(1)

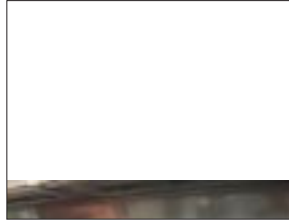

(2)



(3)

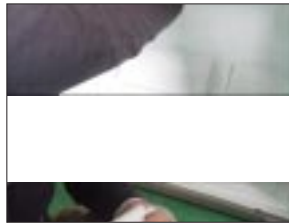

(4)

3-5 DEFROST CONTROL ASSEMBLY

Defrost Control assembly consists of Defrost Sensor and FUSE-M.

The Defrost Sensor works to defrost automatically. It is attached to the metal side of the Evaporator and senses its temperature. At 72°C, it turns the Defrost Heater off.

Fuse-M is a safety device for preventing over-heating of the Heater when defrosting.

1. Pull out the grille assembly. (Figure 12)
2. Separate the connector with the Defrost Control assembly and replace the Defrost Control assembly after cutting the Tie Wrap. (Figure 13)



GRILLE ASSEMBLY

Figure 12



DEFROST-CONTROL ASSEMBLY

Figure 13

3-6 LAMP

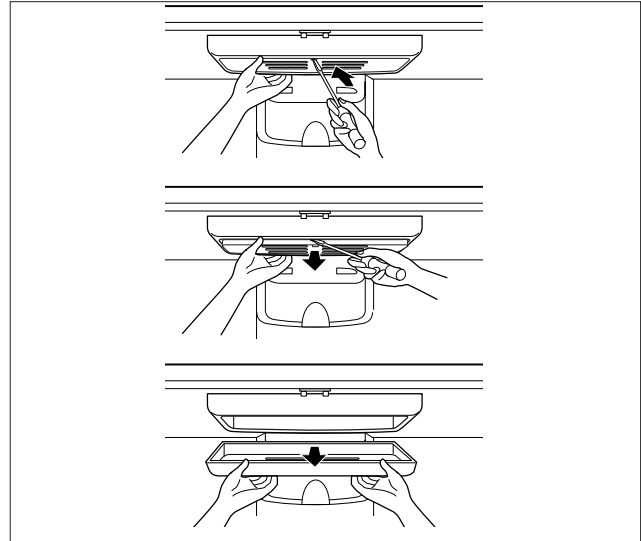

To change Refrigerator Light Bulbs

1. Unplug Refrigerator, or disconnect power at the circuit breaker.
2. If necessary, remove top shelf or shelves.
3. Using a flat instrument, gently pry the lamp cover loose in the front as shown. Rotate downward to remove rear tabs.
4. Make sure the bulbs are cool to the touch. Turn bulbs counterclockwise to remove. Insert new bulb(s).
5. Assemble in reverse order by snapping the Lamp Cover in, engaging the rear tabs followed by the front tabs.

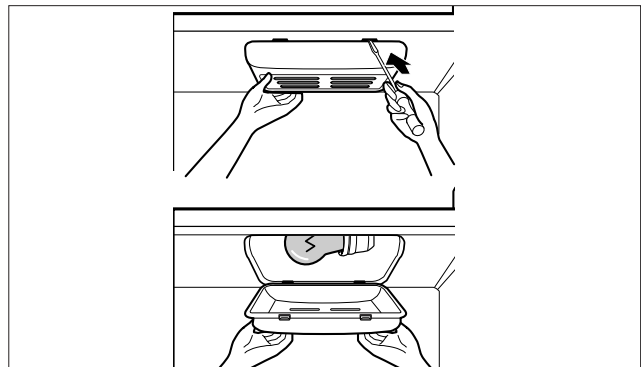

To change freezer light

NOTE: Some models have LED interior lighting and service should be performed by a qualified technician.

1. Unplug refrigerator power cord from outlet.
2. Using a flat instrument, gently pry the lamp cover loose in the front as shown. Rotate downward to remove the rear tabs.
3. Make sure the bulb is cool to the touch. Turn the bulb counterclockwise to remove.
4. Replace with a new 60-watt appliance bulb.
5. Insert tabs on back of cover into slots in freezer ceiling. Push cover up to snap front into place.

3-7 MULTI DUCT

1. Remove the upper and lower Caps by using a flat screwdriver, and remove 2 screws. (Figure 17)
2. Disconnect the lead wire on the bottom position.

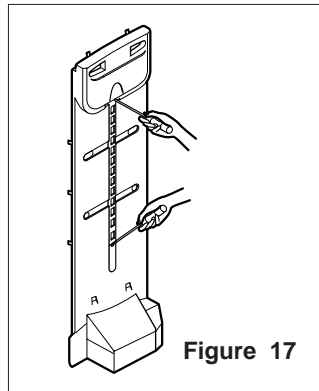

3-8 MAIN PWB

- 1) Loosen the 3 screws on the PWB cover.



- 2) Remove the PWB cover



- 3) Disconnect wire harness and replace the main PWB in the reverse order of removal.



3-9 DISPENSER

- 1) Disconnect funnel and button assembly by pulling down and forward.



- 2) Remove display frame assembly by making a gap between a display frame assembly and door with a flat blade screwdriver and pulling it forward. The cover dispenser is attached with a hook.



- ⚠ CAUTION:** When replacing the dispenser cover in the reverse order of removal, be careful that the lead wire does not come out and the water tube is not pinched by the dispenser cover, as shown in the picture below.

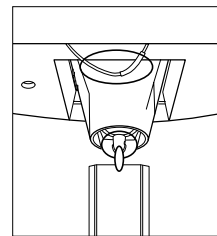

3-10 DISPLAY PWB REPLACEMENT

- 1) Pull up and out on the dispenser cover to remove.



- 2) Follow the steps in the pictures

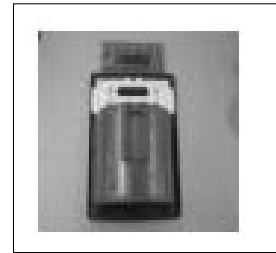
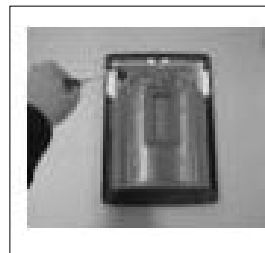

3-11 FUNNEL REPLACEMENT

- 1) Pull up and out on the dispenser cover to remove.
- 2) Disconnect the wire harness.
- 3) Replace in reverse order.



3-12 SUB PWB FOR WORKING DISPENSER

- 1) Loosen the screw on the sub PWB.



- 2) Pull the sub PWB down.
- 3) Disconnect the wire harness and replace the sub PWB in the reverse order of removal.



3-13 DUCT DOOR REPLACEMENT

- 1) Pull up and out on the dispenser cover to remove.
- 2) Disconnect the wire harness.
- 3) Remove the funnel
- 4) Replace in reverse order.



3-14 ICE CORNER DOOR REPLACEMENT

- 1) Loosen the front screw as shown in the picture.
- 2) Lift up the hinge with one hand.
- 3) Pull out the Ice Corner Door with the other hand.



3-15 ICEMAKER ASSEMBLY

- 1) Loosen two screws as shown in the first picture.

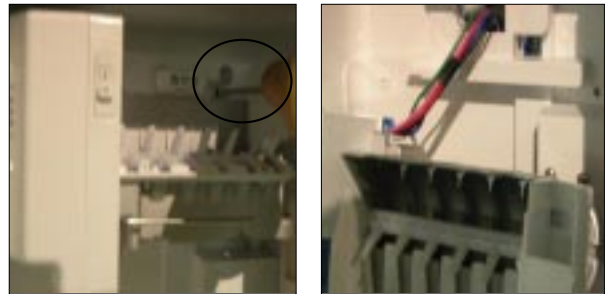

- 2) Disconnect the wire harness & ground screw replace the icemaker assembly in the reverse order of removal.



- 3) It separates a ground connection screw.



3-16 AUGER MOTOR COVER

- 1) After removing the icemaker remove the (5) stainless screws holding the auger motor cover, shown in the pictures below.

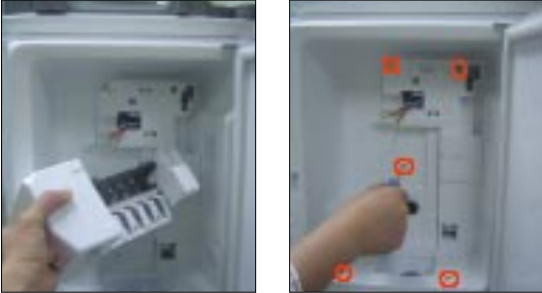

- 2) Grip the bottom of motor cover assembly and pull out it.



- 3) Disconnect wire harness of motor cover assembly.
There is a auger motor on the back, as shown in the picture.

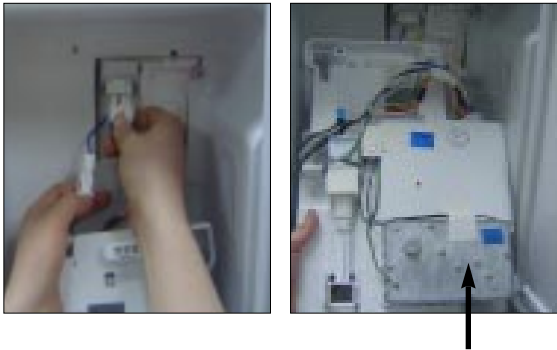

Auger Motor

3-17 HOW TO REMOVE A DOOR ICE BIN

1) Grip the handles, as shown in the picture.

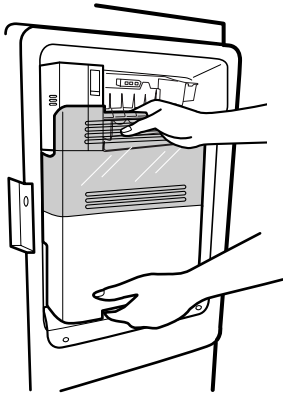

2) Lift the lower part slightly.

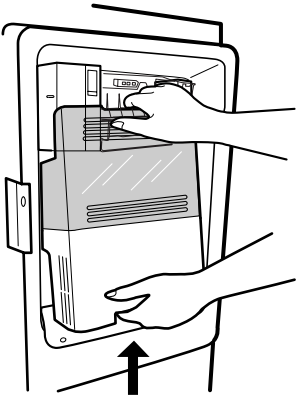

3) Take the Ice Bin out slowly.

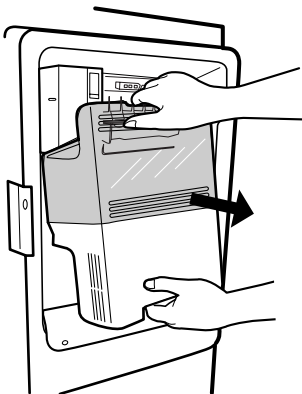

3-18 HOW TO INSERT A DOOR ICE BIN

1) Insert the Ice Bin, slightly tilting it to avoid touching the icemaker. (especially, ice maker lever)

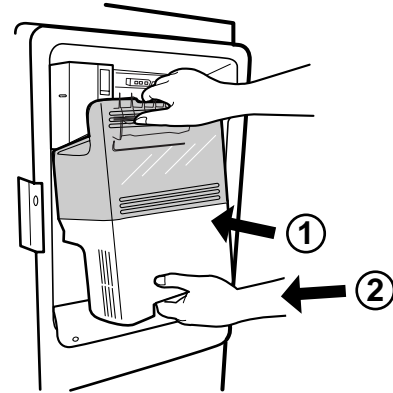

※ Insert the ice bucket carefully avoid contacting the automatic shut off arm.

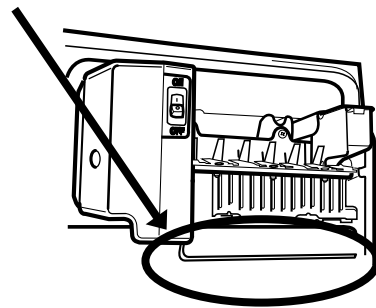

3-19 HOW TO REMOVE AND REINSTALL THE PULLOUT DRAWER

3-19-1 Follow Steps to Remove

Step 1) Open the freezer door.



Step 2) Remove the lower basket.



Step 3) Remove the two screws from the guide rails (one from each side).

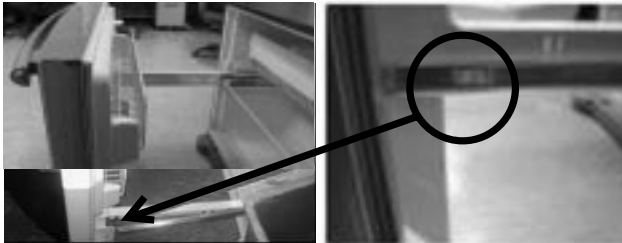

Step 4) Lift the freezer door up to unhook it from the rail support and remove. Pull both rails to full extension.



Step 5) First: Remove the gear from the left side first by releasing the tab behind the gear, place a screwdriver between the gear and the tab and pull up on the gear.

Second: Remove the center rail.

Third: Remove the gear from the right side by following the same steps for the left side.

NOTE: THIS TAB MUST BE PUSHED IN TO RELEASE THE GEAR.

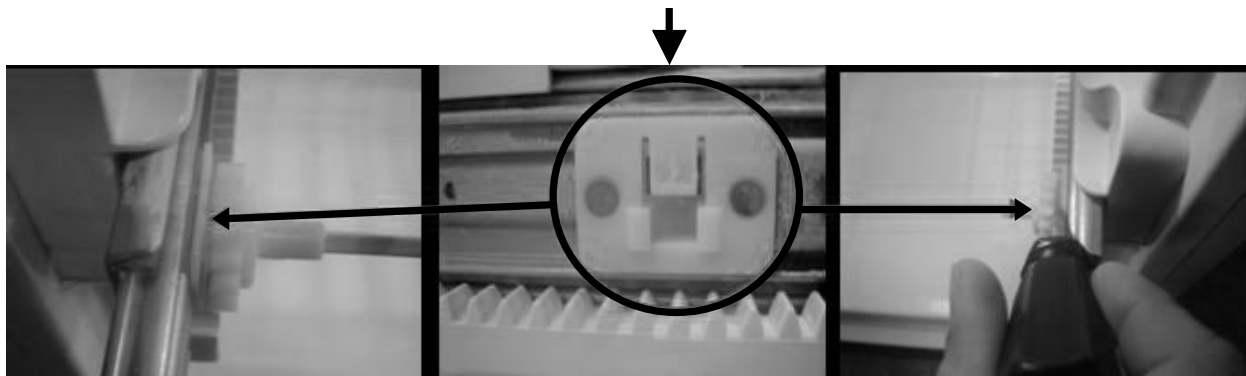

3-19-2 Follow Steps to Reinstall

Step 1) Reinstall the right side gear into the clip.



Step 2) Insert the rail into the right side gear. Gears do **not** need to be perpendicular to each other.



Step 3) Insert the rail into the left side gear, and insert the gear into the clip.



Step 4) The rail system will align itself by pushing the rails all the way into the freezer section. Pull the rails back out to full extension.

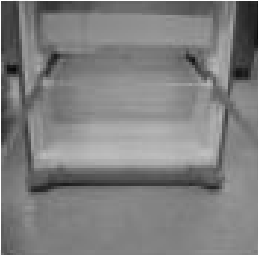

Step 6) Reinstall the two screws into the guide rails (one from each side).

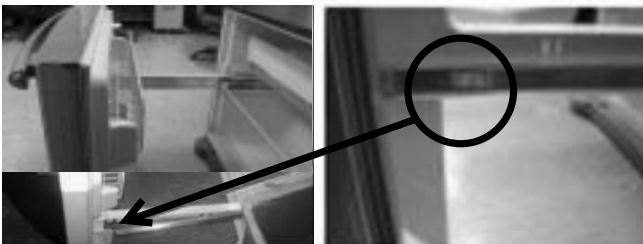

Step 5) Reinstall the freezer door by inserting the rail tabs into the guide rail.



Step 7) Reinstall the lower basket, and close the freezer door.



3-20. WATER VALVE DISASSEMBLY METHOD

1) Turn off the water. Then separate the water line from the valve.

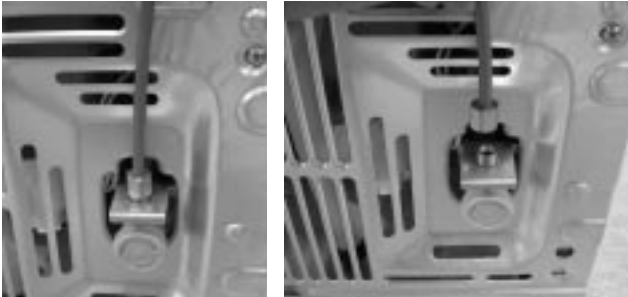

2). Separate the Mechanical Cover and Valve Screw.

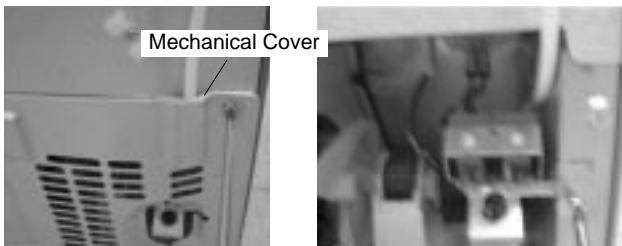

3) Separate the housing and pull out the valve.

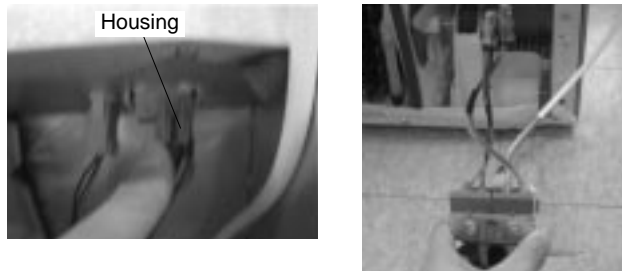

4) Lay a dry towel on the floor and get ready to spill water from the water filter. Pull out the Cilp. Then press te collet to separate the tube from the connector and pour out the water until emptied.

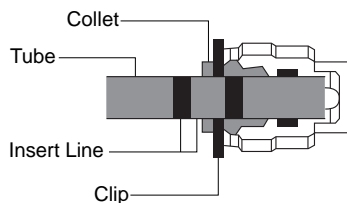

3-21. FAN AND FAN MOTOR DISASSEMBLY METHOD

1) Using a short screwdriver, loosen one SCREW in DRAIN PIPE ASSEMBLY and one connected to the MOTOR COVER.

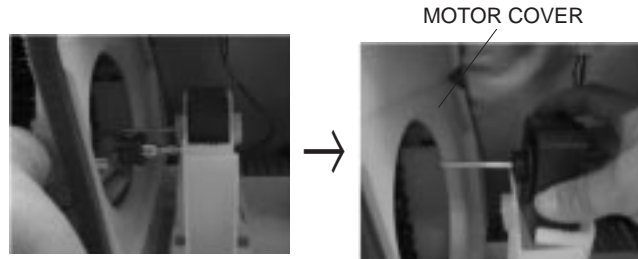

2) Pull and separate the FAN ASSEMBLY and MOTOR turning counterclockwise based on the MOTOR SHAFT.

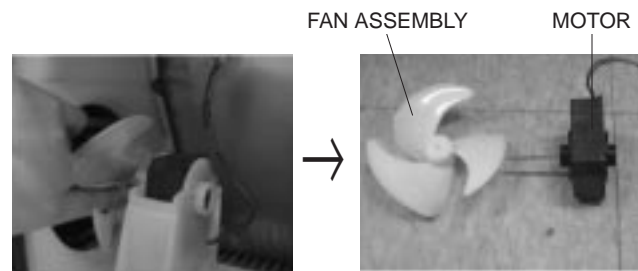

The assembly is in the reverse order of the disassembly and take special care for the following details.

1. Be careful not to bend the tube during assembly.
2. Press the WATER DISPENSER button until water pours out and check for leakage in the CONNECTOR TUBE (It differs by the water pressure but usually takes about 2 minutes until water pours out.)

3-22 PULL OUT DRAWER

To separate the drawer, push the front left and right hooks in ① direction to pull up and remove. Then gently lift the gear part of rear left and right side of the drawer and pull it out in ③ direction.

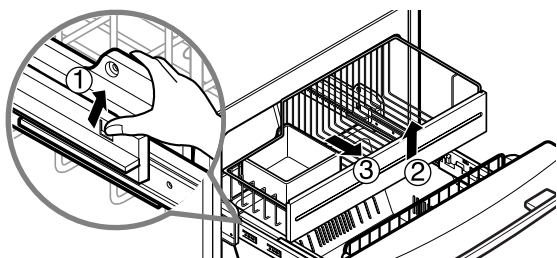

To install, reposition the gear part of rear left and right side of the drawer after pulling out both rails as much as possible, and gently push down both left and right side while checking the hook on the front part.

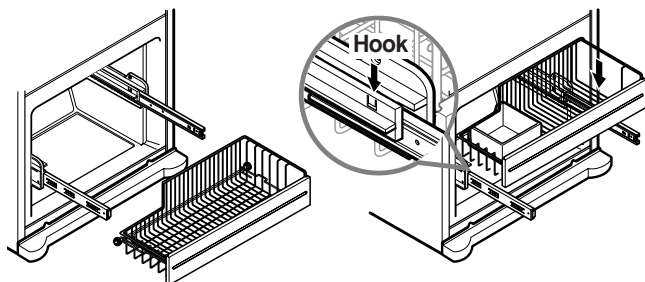

4. ADJUSTMENT

4-1 COMPRESSOR

4-1-1 Role

The compressor intakes low temperature and low pressure gas from the evaporator of the refrigerator and compresses this gas to high-temperature and high-pressure gas. It then delivers the gas to the condenser.

4-1-2 Composition

The compressor includes overload protection. The PTC starter and OLP (overload protector) are attached to the outside of the compressor. Since the compressor is manufactured to tolerances of 1 micron and is hermetically sealed in a dust and moisture-free environment, use extreme caution when performing repairs.

4-1-3 Note for Usage

- (1) Be careful not to allow over-voltage and over-current.
- (2) If compressor is dropped or handled carelessly, poor operation and noise may result.
- (3) Use proper electric components appropriate to the Particular Compressor in your product.
- (4) Keep Compressor dry.
If the Compressor gets wet (in the rain or a damp environment) and rust forms in the pin of the Hermetic Terminal, poor operation and contact may result.
- (5) When replacing the Compressor, be careful that dust, humidity, and soldering flux don't contaminate the inside of the compressor. Dust, humidity, and solder flux contaminate the cylinder and may cause noise, improper operation or even cause it to lock up.

4-2 PTC-STARTER

4-2-1 Composition of PTC-Starter

- (1) PTC (Positive Temperature Coefficient) is a no-contact semiconductor starting device which uses ceramic material consisting of BaTiO₃.
- (2) The higher the temperature is, the higher the resistance value. These features are used as a starting device for the Motor.

4-2-2 Role of PTC-Starter

- (1) The PTC is attached to the Sealed Compressor and is used for starting the Compressor Motor.
- (2) The compressor is a single-phase induction motor. The starting operation, the PTC allows current flow to both the start winding and main winding.

4-2-3 PTC-Applied Circuit Diagram

● Starting Method for the Motor

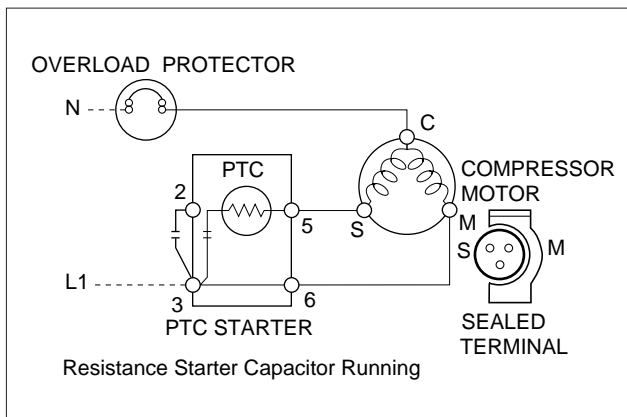

4-2-4 Motor Restarting and PTC Cooling

- (1) It requires approximately 5 minutes for the pressure to equalize before the compressor can restart.
- (2) The PTC device generates heat during operation. Therefore, it must be allowed to cool before the compressor can restart.

4-2-5 Relation of PTC-Starter and OLP

- (1) If the compressor attempts to restart before the PTC device is cooled, the PTC device will allow current to flow only to the main winding.
- (2) The OLP will open because of the over current condition. This same process will continue (3 to 5 times) when the compressor attempts to restart until the PTC device has cooled. The correct OLP must be properly attached to prevent damage to the compressor.

Parts may appear physically identical but could have different electrical ratings. Replace parts by part number and model number. Use only approved substitute parts.

4-2-6 Note for Using the PTC-Starter

- (1) Be careful not to allow over-voltage and over-current.
- (2) Do not drop or handle carelessly.
- (3) Keep away from any liquid.
If liquid such as oil or water enters the PTC, PTC materials may fail due to breakdown of their insulating capabilities.
- (4) If the exterior of the PTC is damaged, the resistance value may be altered. This can cause damage to the compressor and result in a no-start or hard-to-start condition.
- (5) Always use the PTC designed for the compressor and make sure it is properly attached to the compressor. Parts may appear physically identical but could have different electrical ratings. Replace parts by part number and model number. Use only approved substitute parts.

4-3 OLP (OVERLOAD PROTECTOR)

4-5-1 Definition of OLP

- (1) OLP (OVERLOAD PROTECTOR) is attached to the Compressor and protects the Motor by opening the circuit to the Motor if the temperature rises and activating the bimetal spring in the OLP.
- (2) When high current flows to the Compressor motor, the Bimetal works by heating the heater inside the OLP, and the OLP protects the Motor by cutting off the current flowing to the Compressor Motor.

4-5-2 Role of the OLP

- (1) The OLP is attached to the Sealed Compressor used for the Refrigerator. It prevents the Motor Coil from being started in the Compressor.
- (2) For normal operation of the OLP, do not turn the Adjust Screw of the OLP in any way.

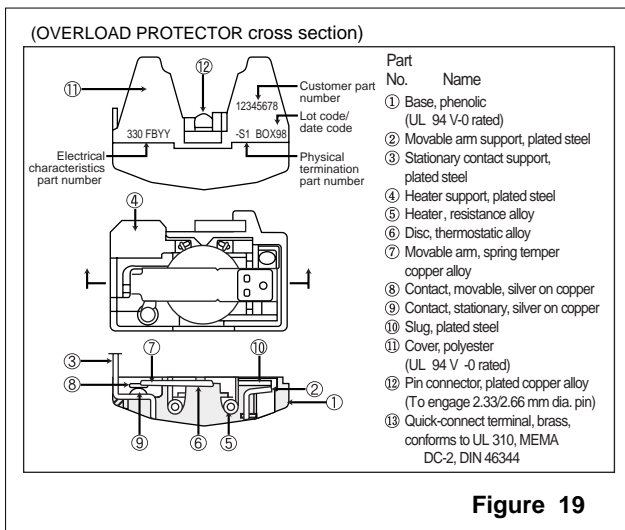
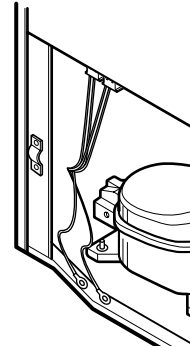
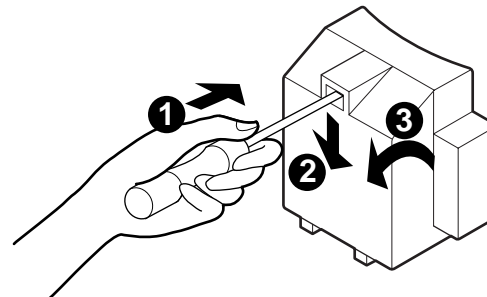

Figure 19

4-4 TO REMOVE THE COVER PTC



- (1) Remove the Cover Back M/C.
- (2) Disconnect two housing upper side of comp connected in.
- (3) Loosen two screws on comp base.



- (4) Use a L-shaped flap tool to pry off the cover.
- (5) Assembly in reverse order of disassembly.

5. CIRCUIT DIAGRAM

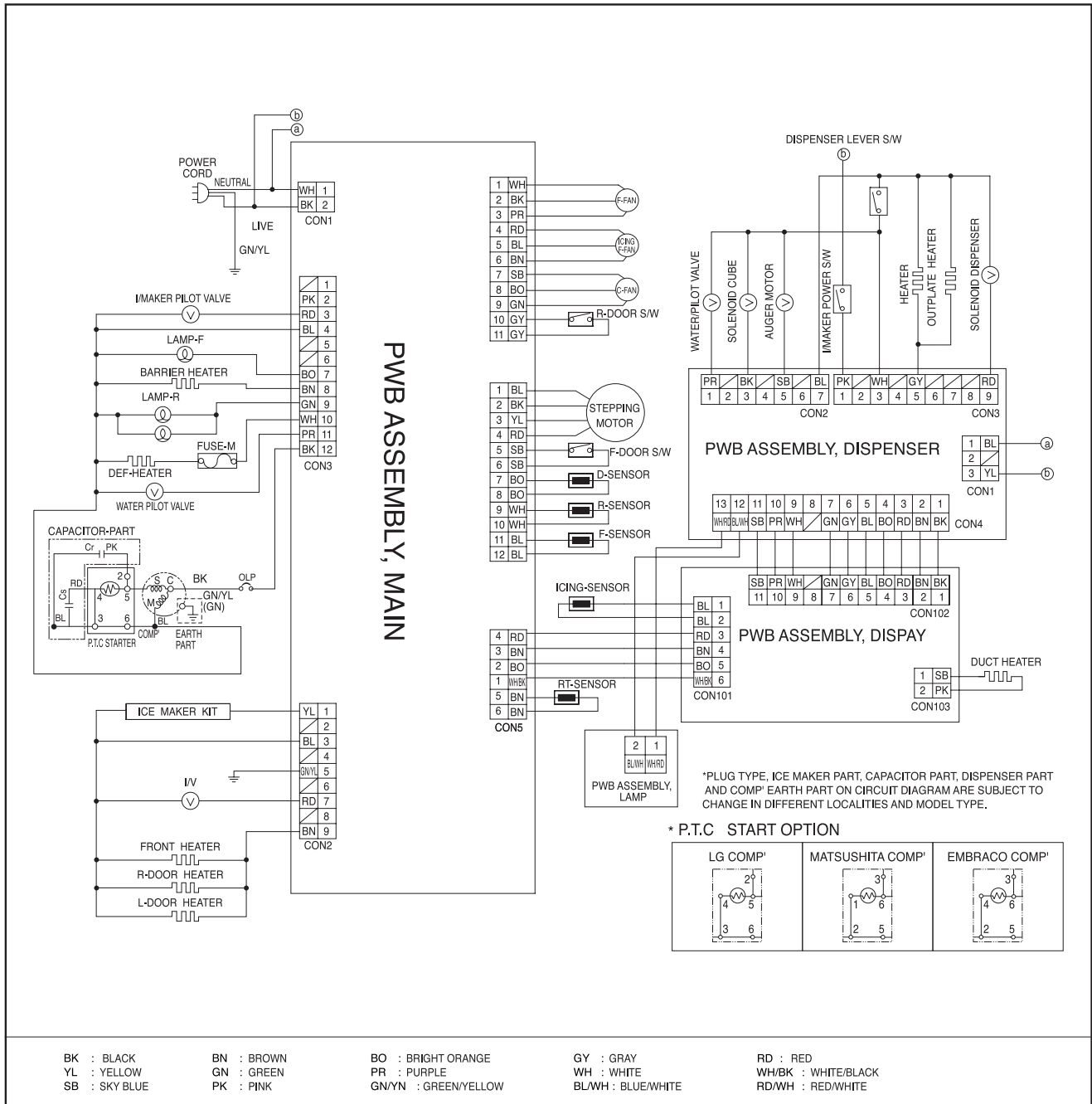

6. TROUBLESHOOTING

6-1 COMPRESSOR AND ELECTRIC COMPONENTS

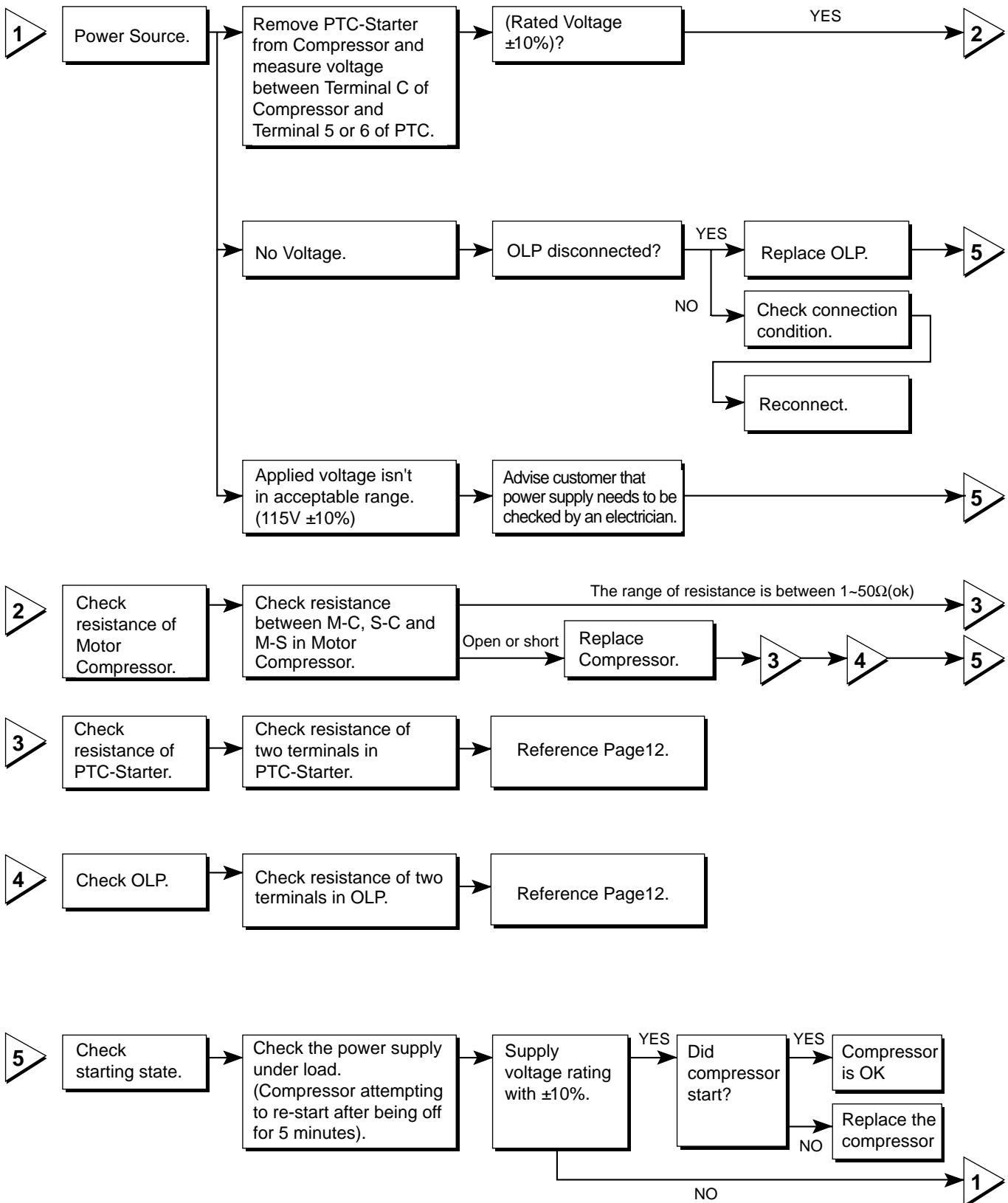

6-2 OTHER ELECTRICAL COMPONENTS

▼ Not cooling at all

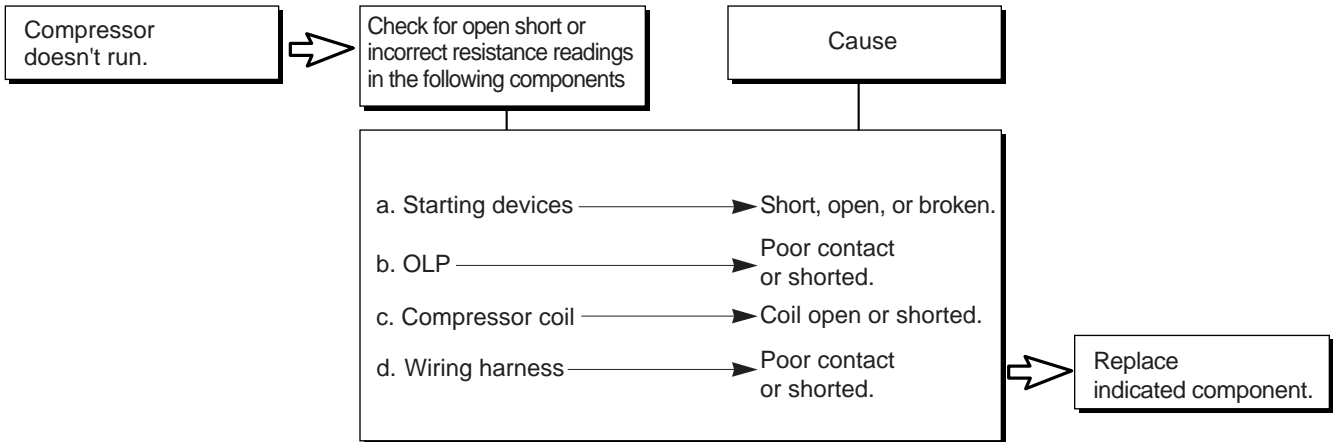

▼ Poor cooling performance

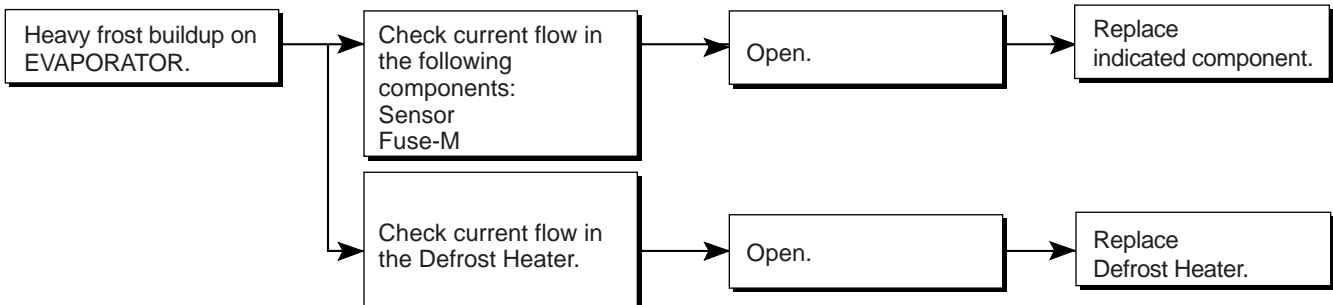
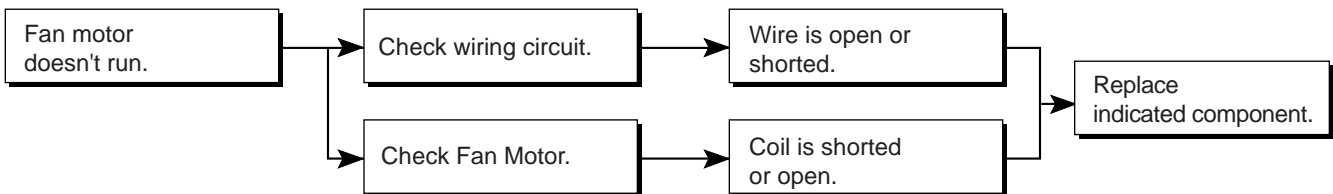
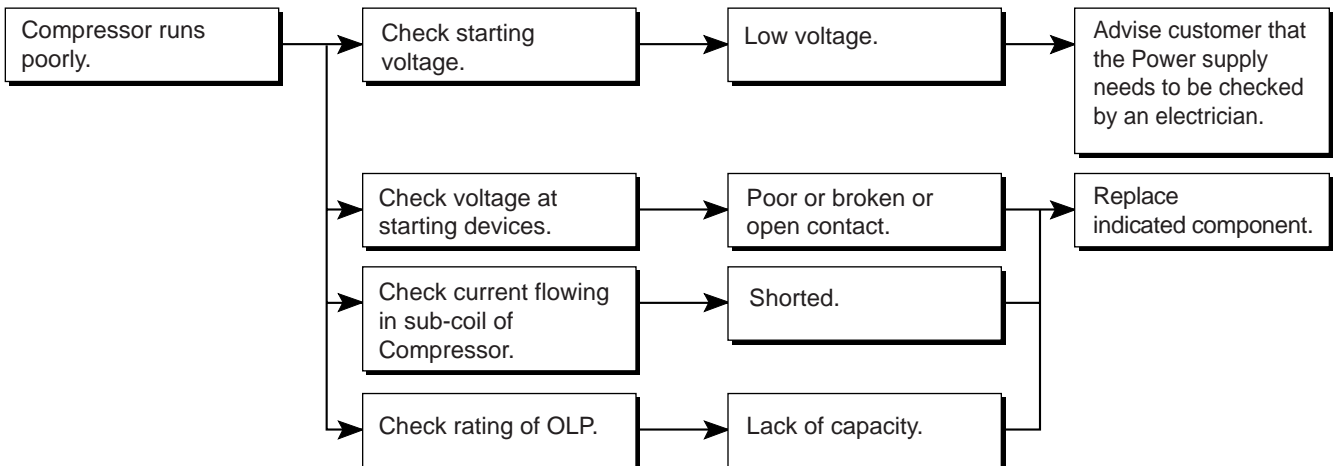

6-3 SERVICE DIAGNOSIS CHART

COMPLAINT	POINTS TO BE CHECKED	REMEDY
No Cooling.	<ul style="list-style-type: none"> • Is the power cord unplugged from the outlet? • Check if the power switch is set to OFF. • Check if the fuse of the power switch is shorted. • Measure the voltage of the power outlet. 	<ul style="list-style-type: none"> • Plug into the outlet. • Set the switch to ON. • Replace the fuse. • If the voltage is low, correct the wiring.
Cools poorly.	<ul style="list-style-type: none"> • Check if the unit is placed too close to the wall. • Check if the unit is placed too close to the stove, gas cooker, or in direct sunlight. • Is the ambient temperature too high or the room door closed? • Check if food put in the refrigerator is hot. • Did you open the door of the unit too often or check if the door is sealed properly? • Check if the Control is set to Warm position. 	<ul style="list-style-type: none"> • Place the unit about 4 inches (10 cm) from the wall. • Place the unit away from these heat sources. • Lower the ambient temperature. • Put in foods after they have cooled down. • Don't open the door too often and close it firmly. • Set the control to Recommended position.
Food in the Refrigerator is frozen.	<ul style="list-style-type: none"> • Is food placed in the cooling air outlet? • Check if the control is set to colder position. • Is the ambient temperature below 41°F(5°C)? 	<ul style="list-style-type: none"> • Place foods in the high-temperature section. (front part) • Set the control to Recommended position. • Set the control to Warm position.
Condensation or ice forms inside the unit.	<ul style="list-style-type: none"> • Is liquid food sealed? • Check if food put in the refrigerator is hot. • Did you open the door of the unit too often or check if the door is sealed properly? 	<ul style="list-style-type: none"> • Seal liquid foods with wrap. • Put in foods after they have cooled down. • Don't open the door too often and close it firmly.
Condensation forms in the Exterior Case.	<ul style="list-style-type: none"> • Check if the ambient temperature and humidity of the surrounding air are high. • Is there a gap in the door gasket? 	<ul style="list-style-type: none"> • Wipe moisture with a dry cloth. It will disappear in low temperature and humidity. • Fill up the gap.
There is abnormal noise.	<ul style="list-style-type: none"> • Is the unit positioned in a firm and even place? • Are any unnecessary objects placed in the back side of the unit? • Check if the Drip Tray is not firmly fixed. • Check if the cover of the compressor enclosure in the lower front side is taken out. 	<ul style="list-style-type: none"> • Adjust the Leveling Screw, and position the refrigerator in a firm place. • Remove the objects. • Fix the Drip Tray firmly in the original position. • Place the cover in its original position.
Door does not close well.	<ul style="list-style-type: none"> • Check if the door gasket is dirty with an item like juice. • Is the refrigerator level? • Is there too much food in the refrigerator? 	<ul style="list-style-type: none"> • Clean the door gasket. • Position in a firm place and level the Leveling Screw. • Make sure food stored in shelves does not prevent the door from closing.
Ice and foods smell unpleasant.	<ul style="list-style-type: none"> • Check if the inside of the unit is dirty. • Are foods with a strong odor unwrapped? • The unit smells of plastic. 	<ul style="list-style-type: none"> • Clean the inside of the unit. • Wrap foods that have a strong odor. • New products smell of plastic, but this will go away after 1-2 weeks.

● Other possible problems:

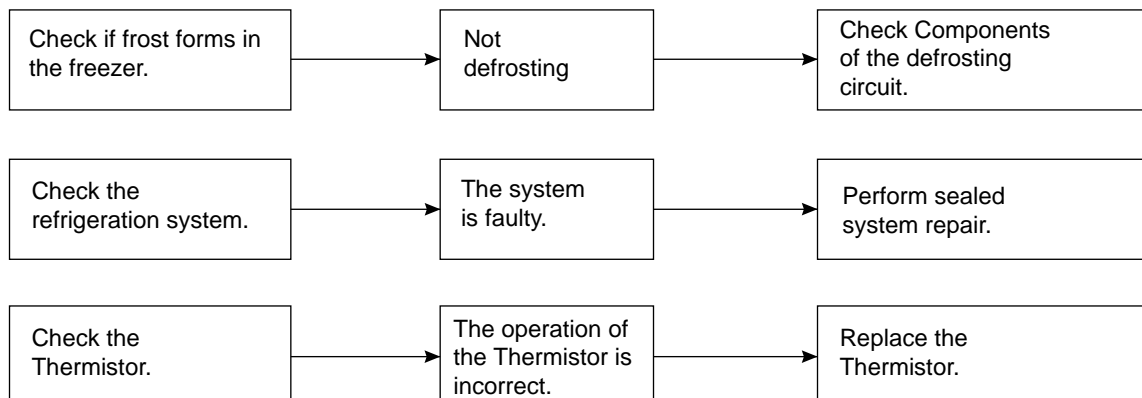

6-4 REFRIGERATION CYCLE

▼ Troubleshooting Chart

CAUSE		STATE OF THE UNIT	STATE OF THE EVAPORATOR	TEMPERATURE OF THE COMPRESSOR	REMARKS
LEAKAGE	PARTIAL LEAKAGE	Freezer compartment and Refrigerator don't cool normally.	Low flowing sound of Refrigerant is heard and frost forms in inlet only.	A little higher than ambient temperature.	<ul style="list-style-type: none"> Refrigerant level is low due to a leak. Normal cooling is possible by restoring the normal amount of refrigerant and repairing the leak.
	COMPLETE LEAKAGE	Freezer compartment and Refrigerator don't cool normally.	Flowing sound of refrigerant is not heard and frost isn't formed.	Equal to ambient temperature.	<ul style="list-style-type: none"> No discharging of Refrigerant. Normal cooling is possible by restoring the normal amount of refrigerant and repairing the leak.
CLOGGED BY DUST	PARTIAL CLOG	Freezer compartment and Refrigerator don't cool normally.	Flowing sound of refrigerant is heard and frost forms in inlet only.	A little higher than ambient temperature.	<ul style="list-style-type: none"> Normal discharging of the refrigerant. The capillary tube is faulty.
	WHOLE CLOG	Freezer compartment and Refrigerator don't cool.	Flowing sound of refrigerant is not heard and frost isn't formed.	Equal to ambient temperature.	<ul style="list-style-type: none"> Normal discharging of the Refrigerant.
MOISTURE CLOG		Cooling operation stops periodically.	Flowing sound of refrigerant is not heard and frost melts.	Lower than ambient temperature.	<ul style="list-style-type: none"> Cooling operation restarts when heating the inlet of the capillary tube.
DEFECTIVE COMPRESSION	COMP-RESSION	Freezer and Refrigerator don't cool.	Low flowing sound of refrigerant is heard and frost forms in inlet only.	A little higher than ambient temperature.	<ul style="list-style-type: none"> Low pressure at high side of compressor due to low refrigerant level.
	NO COMP-RESSION	No compressing operation.	Flowing sound of refrigerant is not heard and there is no frost.	Equal to ambient temperature.	<ul style="list-style-type: none"> No pressure in the high pressure part of the compressor.

6-4-1 SEALED SYSTEM DIAGNOSIS

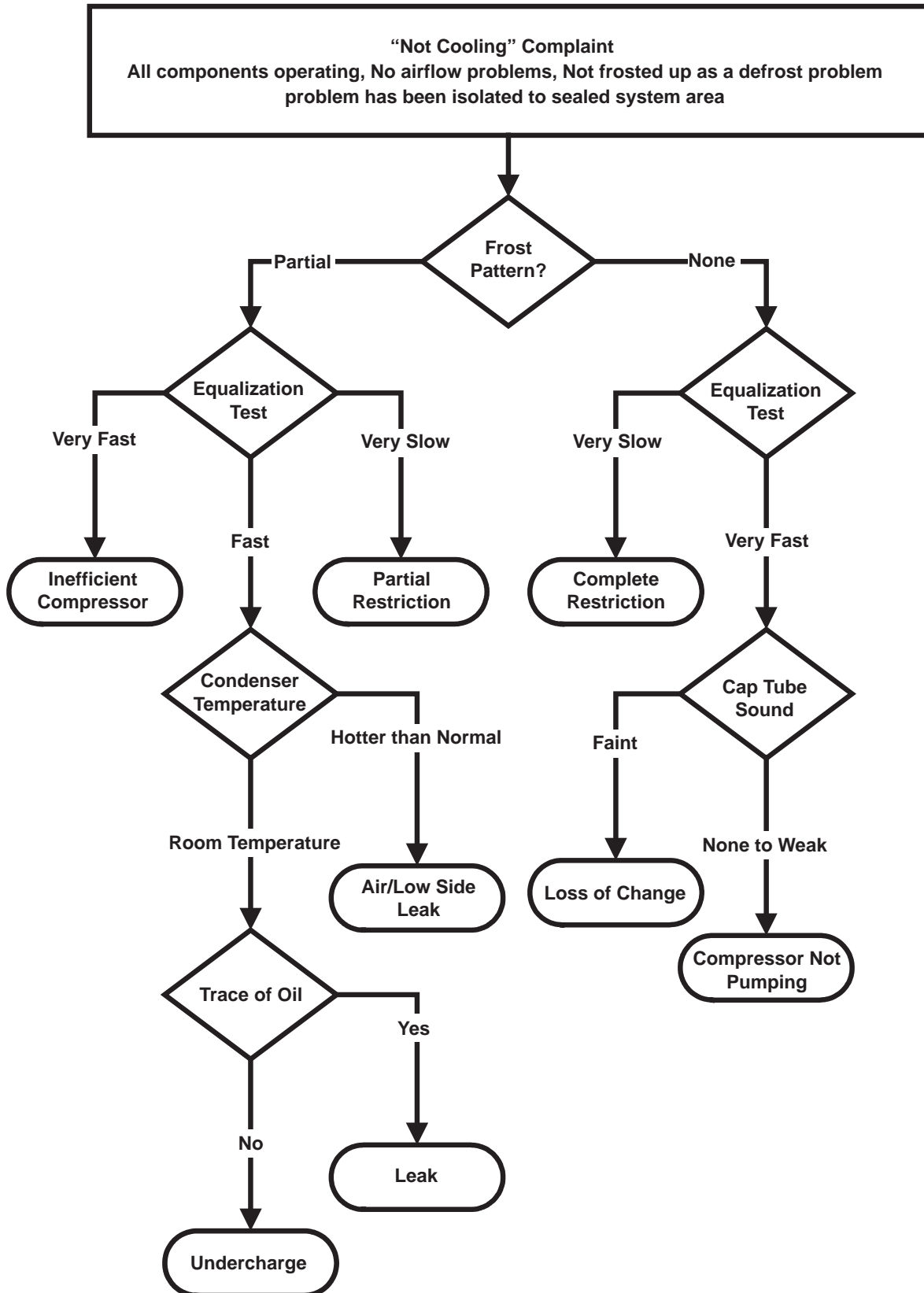

(The equalization test is trying to restart a compressor using a start kit after it has been operating.)

7. OPERATION PRINCIPLE AND REPAIR METHOD OF ICEMAKER

7-1 OPERATION PRINCIPLE

7-1-1 Operation Principle of IceMaker

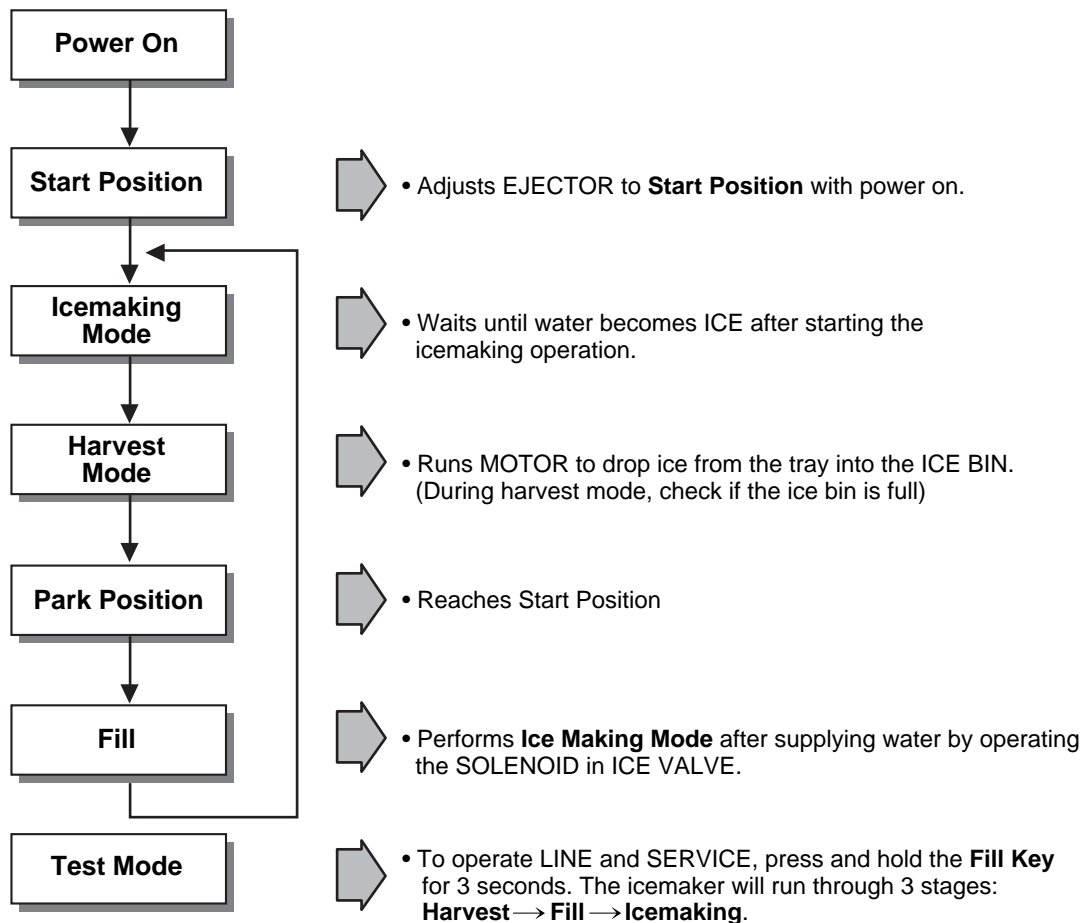

1. Turning the Icemaker stop switch off (O) stops the ice making function.
2. Setting the Icemaker switch to OFF and then turning it back on will reset the icemaker control.

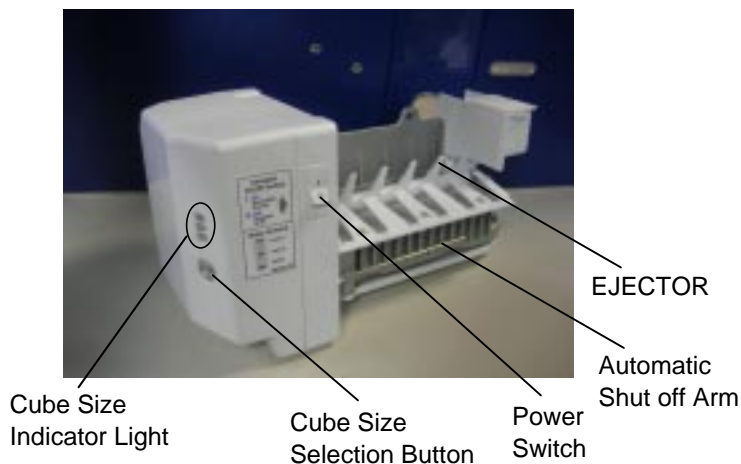

7-2 ICE MAKER FUNCTIONS

7-2-1. Icemaking Mode

1. Icemaking refers to the freezing of supplied water in the ice tray. Complete freezing is assured by measuring the temperature of the Tray with Icemaking SENSOR.
2. Icemaking starts after completion of the water fill operation.
3. The Ice Making function is completed when the sensor reaches 19°F (-7°C), 55 minutes after starting.

NOTE : After Icemaker Power is ON, the Icemaker heater will be on for test for 6 sec.



7-2-2. Harvest Mode

1. Harvest (Ice removing) refers to the operation of dropping ices into the ice bin from the tray when icemaking has completed.
 2. Harvest mode:
 - (1) The Heater is ON for 30 seconds, then the motor starts.
 - (2) The feeler arm senses the quantity of ice in the ice storage bin while rotating with the EJECTOR.
 - A. Ice storage bin is full : The EJECTOR stops (heater off).
 - B. Ice storage bin is not full : The EJECTOR rotates twice to open for ice.
- ※ If the EJECTOR does not rotate once within 5 minutes in B mode, separate heater control mode starts operating to prevent the EJECTOR from being constrained. (It is recommended that the user open for ice to return to normal mode.)

7-2-3. Fill/Park Position

1. Once a normal harvest mode has been completed, the water solenoid will be activated.
2. The amount of water is adjusted by pressing the Fill Key repeatedly. This changes the time allowed for fill as illustrated in the table below.





Water supply amount TABLE

STAGE	TIME TO SUPPLY	INDICATIONS	REMARKS
1	5 sec.		The water amount will vary depending on the water control Switch setting, as well as the water pressure of the connected water line.
2	5.5 sec. (FIRST STAGE)		
3	6 sec.		

7-2-5 Function TEST

1. This is a forced operation for TEST, Service, cleaning, etc. It is operated by pressing and holding the Fill Key for 3 seconds.
2. The test works only in the Icemaking Mode. It cannot be entered from the Harvest or Fill mode.
3. **Caution!** If the test is performed before water in the icemaker is frozen, the ejector will pass through the water. When the Fill mode begins (Stage 4), unless the water supply has been shut off, added water will overflow into the ice bin. If the control doesn't operate normally in the TEST mode, check and repair as needed.
4. After water is supplied, the normal CYCLE is followed: **icemaking** → **Harvest** → **Park Position** → **Fill**.
5. Five seconds after Stage 5 is completed, the Ice Maker returns to MICOM control. The time needed to supply water resets to the pre- test setting.

Diagnosis TABLE

STAGE	ITEMS	INDICATOR	REMARKS
1	HEATER		Five seconds after heater starts, a heater will go off if the temperature by sensor is higher than 10°C
2	MOTOR		Five seconds after heater starts, you can confirm that a motor is moving.
3	HALL IC I		Check if Ice Bin is full or not. If Ice bin is full, the motor and heater are off and on stand by until Ice bin is empty.
4	HALL IC II		You can confirm HALL IC detection of start position.
5	VALVE		Two seconds after detection of start position, you can confirm that valve is on.
6	Reset	Return to Status prior to TEST MODE	Five seconds after fifth stage is completed, The icemaker resets to initial status.

7-3 DEFECT DIAGNOSIS FUNCTION

7-3-1 ERROR CODES shown on Ice Maker water supply control panel

NO	DIVISION	INDICATOR	CONTENTS	REMARKS
1	Normal	Mark time to supply	None	Display switch operates properly
2	Icemaking Sensor malfunction		Open or short-circuited wire	Make sure that the wire on each sensor is connected.

8. DESCRIPTION OF FUNCTION & CIRCUIT OF MICOM

8-1 FUNCTION

8-1-1 Function

1. When the appliance is plugged in, it is set to 37°F for Refrigerator and 0°F for freezer.
You can adjust the Refrigerator and the Freezer control temperature by pressing the ADJUST button.
2. When the power is initially applied or restored after a power failure, it is set to Control temperature Previously.

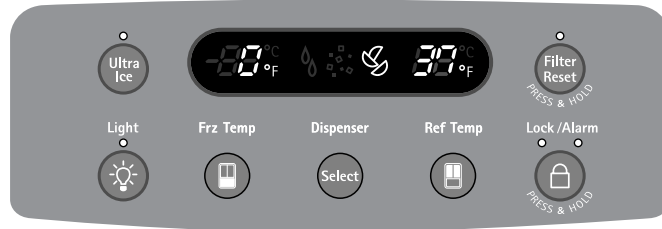

8-1-2 How to Toggle the Display between °F & °C

1. The initial setting is °F and the display temperature mode can be changed from °F to °C or °C to °F by pressing and holding the FRZ TEMP and the REF TEMP keys at the same time for over 5 seconds.

8-1-3 Lock function (dispenser and display button lock)

1. When the refrigerator is first turned on, the buttons are not locked. The display panel shows the padlock unlocked icon.
2. To lock the display, the dispenser, and the control panel, press and hold the LOCK button for 3 seconds. The locked pad lock icon is displayed.
3. The LOCK button is the only control feature that remains active in the locked state. The buzzer sound, other control buttons, and the dispenser are deactivated.
4. To release from the locked state, press and hold the LOCK button again for 3 seconds.

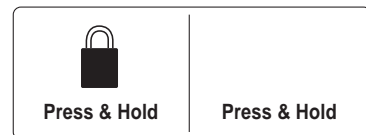

Ex) In selecting "LOCK"

Ex) In selecting "LOCK" again

8-1-4 Filter condition display function

1. There is a replacement indicator light for the filter cartridge on the dispenser.
2. Water filter needs replacement once six months or of using water filter.
3. Water Filter icon turn on to tell you need to replace the filter soon.
4. After replacing the filter, press and hold the lock button more than 3 seconds.
Water Filter icon turn off with reset status.

Classification	In initial Power On / Filter RESET	Replace indicator light on
	Filter Status Display	
	Press & Hold	Press & Hold

8-1-5 Ultra Ice selection

Please select this function for quick freezing.

- Function is repeat Ultra Ice Icon whenever pressing Ultra Ice button.
- Ultra Ice function automatically turns off after a fixed time passes.



8-1-6 Dispenser use selection

You can select water or ice.

- * Select water, crushed ice, or ice cubes by cycling through the selections when pressing the DISPENSER button,
- * Hold your cup in the dispenser for a few seconds after dispensing ice or water to allow the last pieces of ice or drops of water to fall into the cup.
- * When after initially establishing the water comes out, the water tank inside fills and until at the time of quality the hour is caught.

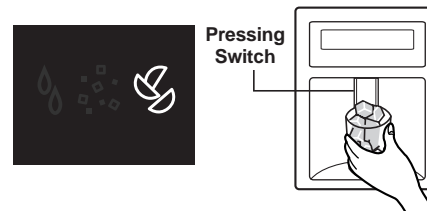

8-1-7 DISPENSER LIGHT

-Whenever pressed the LIGHT button, DISPLAY is changed as follows.



①



②



③

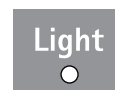

- ① Normal status: When dispenser is operated, DISPENSER LIGHT is ON.
- ② AUTO status: Detecting the lighting of room by LIGHT SENSOR, DISPENSER LIGHT is on and off automatically.
- ③ ON status: DISPENSER LIGHT is on continuously.

8-1-8 CONTROL OF FREEZER FAN MOTOR

1. Freezer fan motor has high and standard speeds.
2. High speed is used at power-up, for Ultra Ice, and when refrigerator is overloaded.
Standard speeds is used for general purposes.
3. To improve cooling speed, the RPM of the freezer fan motor change from normal speed to high.
4. High speed (2700RPM) : Initial power on or load corresponding operation, Ultra Ice.
Normal speed (2400RPM) : General working conditions.
5. Fan motor stops when refrigerator or freezer door opens.

8-1-9 Cooling Fan Motor

1. The cooling fan is switched ON and OFF in conjunction with the compressor.
2. The cooling fan runs at a single speed.
3. The Failure sensing method is the same as in the fan motor of the freezing fan motor(refer to failure diagnosis function table for failure display).

8-1-10 Ice Compartment Fan

1. The Icing Fan is controlled by the the sensor on the top of the ice compartment.
2. The Failure sensing method is the same as in the fan motor of the freezer (refer to failure diagnosis function table for failure display)

8-1-11 Ultra Ice

1. The purpose of this function is to intensify the cooling speed of freezer and to increase the amount of ice.
2. Whenever selection switch is pressed, selection/release, the LED will turn ON or OFF.
3. If there is a power outage and the refrigerator is powered on again, Ultra Ice will be canceled.
4. To activate this function, press the Ultra Ice key and the LED will turn ON. This function will remain activated for 24 hrs. The first three hours the compressor and Freezer Fan will be ON. The next 21 hours the freezer will be controlled at the lowest temperature. After 24 hours or if the Ultra Ice key is pressed again, the freezer will return to its previous temperature.
5. During the first 3 hours:
 - (1) Compressor and freezer fan (HIGH RPM) run continuously.
 - (2) If a defrost cycle begins during the first 90 minutes of Ultra Ice, the Ultra Ice cycle will complete its cycle after defrosting has ended.
If the defrost cycle begins when Ultra Ice has run for more than 90 minutes, Ultra Ice will run for two hours after the defrost is completed.
 - (3) If Ultra Ice is pressed during defrost, Ultra Ice LED is on but this function will start seven minutes after defrost is completed and it shall operate for three hours.
 - (4) If Ultra Ice is selected within seven minutes after compressor has stopped, the compressor (compressor delays seven minutes) shall start after the balance of the delay time.
 - (5) The fan motor in the freezer compartment runs at high speed during Ultra Ice.
6. For the rest of the 21 hours, the freezer will be controlled at the lowest temperature.

8-1-12 FREEZER & REFRIGERATOR LAMP AUTO OFF

1. To avoid heat damage caused by the lamp, it is turned off automatically when the refrigerator door is open for more than 7 minutes.

8-1-13 Alarm for Open Door

1. This feature sounds a buzzer when the freezer or refrigerator door is not closed within 1 minute after it is opened.
2. One minute after the door is opened, the buzzer sounds three times each for 1/2 seconds. These tones repeat every 30 seconds.
3. The alarm is cancelled when the freezer or the refrigerator is closed while the buzzer sounds.

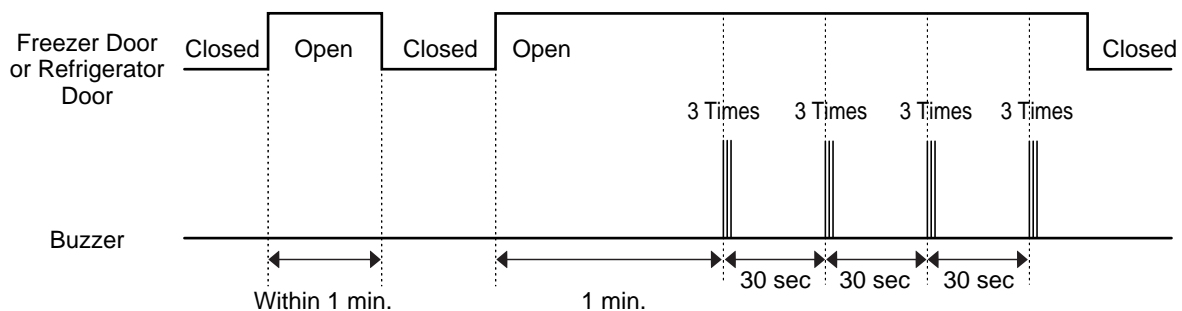

8-1-14 Defrosting (removing frost)

1. Defrosting starts each time the COMPRESSOR running time reaches 7 hours.
2. For initial power on or for restoring power, defrosting starts when the compressor running time reaches 4 hours.
3. Defrosting stops if the sensor temperature reaches 46.4°F(8°C) or more. If the sensor doesn't reach 46.4°F(8°C) in 2 hours, the defrost mode is malfunctioning. (Refer to the defect diagnosis function, 8-1-15.)
4. Defrosting won't function if its sensor is defective (wires are cut or short circuited)

8-1-15 Defect Diagnosis Function

1. Automatic diagnosis makes servicing the refrigerator easy.
2. When a defect occurs, the buttons will not operate; but the tones, such as ding, will sound.
3. When the defect CODE removes the sign, it returns to normal operation (RESET).
4. The defect CODE shows on the Refrigerator and Freezer Display.



- * LCD check function: If simultaneously pressing Ultra Ice button and freezing temperature adjustment button for a second, display LCD graphics on. If releasing the button, the LCD graphic displays the previous status.

ERROR CODE on display panel

NO	Error Detection Category	Error Display		Error Generation Factors	Remark
		Freezer Temperature	Ref. Temperature		
1	Normality			None	Normal operation of Display
2	Freezer Sensor Error	Er	FS	Short or Disconnection of Freezer Sensor	Each Sensor have to check disconnection
3	Refrigerator Sensor Error	Er	rS	Short or Disconnection of Refrigerator Sensor	
4	Defrosting Sensor Error	Er	dS	Short or Disconnection of Defrosting Sensor	
5	Icing Sensor Error	Er	IS	Short or Disconnection of Icing Sensor	
6	Poor Defrosting	Er	dH	Even though it is passed 1 hour since then Defrosting , if Defrosting sensor is not over 8°C, it is caused	Temperature Fuse Disconnection, Heater disconnection, DRAIN Jam, Poor Relay for Heater
7	Abnormality of BLDC FAN Motor for Ice Making	Er	IF	It is caused when F/B signal isn't over 115 seconds during BLDC FAN motor operating	Poor BLDC Motor connection, DRIVE IC, and TR
8	Abnormality of BLDC FAN Motor for Freezer	Er	FF	It is caused when F/B signal isn't over 115 seconds during BLDC FAN motor operating	Poor BLDC Motor connection, DRIVE IC, and TR
9	Abnormality of BLDC FAN Motor for Mechanic Room	Er	CF	It is caused when F/B signal isn't over 115 seconds during BLDC FAN motor operating	Poor BLDC Motor connection, DRIVE IC, and TR
10	Communication Error	Er	CO	Communication Error between Micom of Main PCB and Display Micom	Poor Communication connection, Poor TR of Transmitter and Receiver

8-1-16 TEST Mode

1. The Test mode allows checking the PCB and the function of the product as well as finding out the defective part in case of an error.
2. The test mode is operated by pressing two buttons at Display panel.
3. While in the test mode, the function control button is not recognized, but the recognition tone sounds.
4. After exiting the test mode, be sure to reset by unplugging and then plugging in the appliance.
5. If an error, such as a sensor failure, is detected while in the test mode, the test mode is cleared and the error code is displayed.
6. While an error code is displayed, the test mode will not be activated.

Table 1. Function Test

MODE	OPERATION	FUNCTION	REMARKS
TEST1	Push FREEZER KEY and LOCK KEY at the same time over 5 seconds OR Push Test Switch (in the main Board) once.(See page 39)	<ol style="list-style-type: none"> 1) Continuous operation of the COMPRESSOR and the Freezer fan 2) Stepping DAMPER OPEN 3) Defrosting HEATER OFF 4) DISPLAY LED all ON 	
TEST2	Push FREEZER KEY and LOCK KEY at the same time over 5 seconds in TEST MODE 1 OR Push TEST Switch once in TEST MODE1.(See page 39)	<ol style="list-style-type: none"> 1) Continuous operation of the COMPRESSOR and the Freezer fan 2) Stepping DAMPER CLOSE 3) Defrosting HEATER OFF 4) DISPLAY LED shows no. 2 	
TEST3	Push FREEZER KEY and LOCK KEY at the same time over 5 seconds in TEST MODE 2 OR Push TEST Switch once in TEST MODE2.(See page 39)	<ol style="list-style-type: none"> 1) COMPRESSOR and the Freezer fan OFF 2) Stepping DAMPER CLOSE 3) Defrosting HEATER ON 4) DISPLAY LED shows no. 3 	Reset if the Temperature of the Defrosting Sensor is 46°F(8°C)or more.
RESET	Push FREEZER KEY and LOCK KEY at the same time over 5 seconds in TEST MODE 3 OR Push TEST Switch once in TEST MODE3.(See page 39)	Reset to the previously setting Before TEST MODE.	The compressor will Start after a 7-minute Delay.

8-2 PCB FUNCTION

8-2-1 Power Circuit

1. Power is supplied to the control board at pin1 and 3 of connector #1.

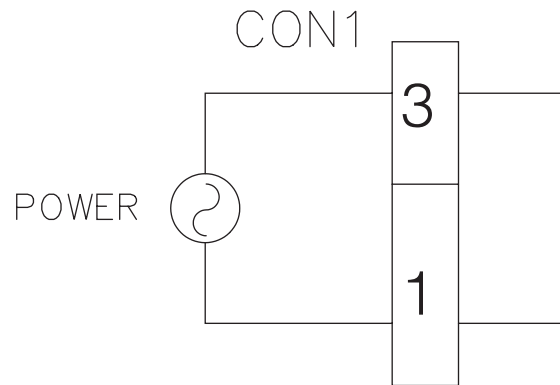

8-2-2 Load / Fan & Open Door Detection Circuit

1. Load Drive Condition Check

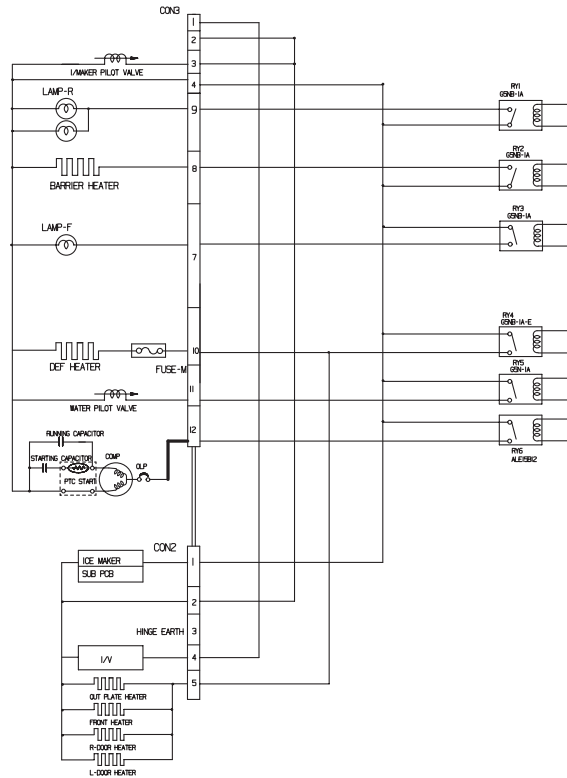

To measure outputs of the control board, check voltages between the pins for the following components:

Circuit	Pin Number	Pin Number	Output Voltage
I/Maker Pilot Valve	Con3 Pin3	Con3 Pin2	115 VAC
Lamp-R	Con3 Pin9	Con3 Pin2	115 VAC
Barrier Heater	Con3 Pin8	Con3 Pin2	115 VAC
Lamp-F	Con3 Pin7	Con3 Pin2	115 VAC
Def Heater	Con3 Pin10	Con3 Pin2	115 VAC
Water Pilot Valve	Con3 Pin11	Con3 Pin2	115 VAC
Compressor	Con3 Pin12	Con3 Pin2	115 VAC
Out Plate, Front, R-Door, L-Door Heater	Con2 Pin5	Con3 Pin2	115 VAC

NOTE: When the door of the freezer/refrigerator is left open for 7 minutes or longer, the lamp of the freezer/refrigerator turns.

2-1. Freezing compartment fan

	Pin1 & 2 of con4
MOTOR OFF	2V or less
MOTOR ON	13V~15V

2-2. Machine compartment fan

	Pin7 & 8 of con4
MOTOR OFF	2V or less
MOTOR ON	13V~15V

2-3. Icing compartment fan

	Pin4 & 5 of con4
MOTOR OFF	2V or less
MOTOR ON	13V~15V

3. Open Door Detection Circuit Check

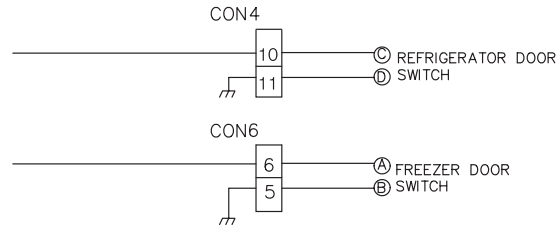

Measurement Location Freezer/ Refrigerator Door	Pin 10 & 11 of con4 Ref.Door Pin 5 & 6 of con6 Fre.Door
Closed	0 V
Open	5 V

8-2-3 Temperature Sensor Circuit

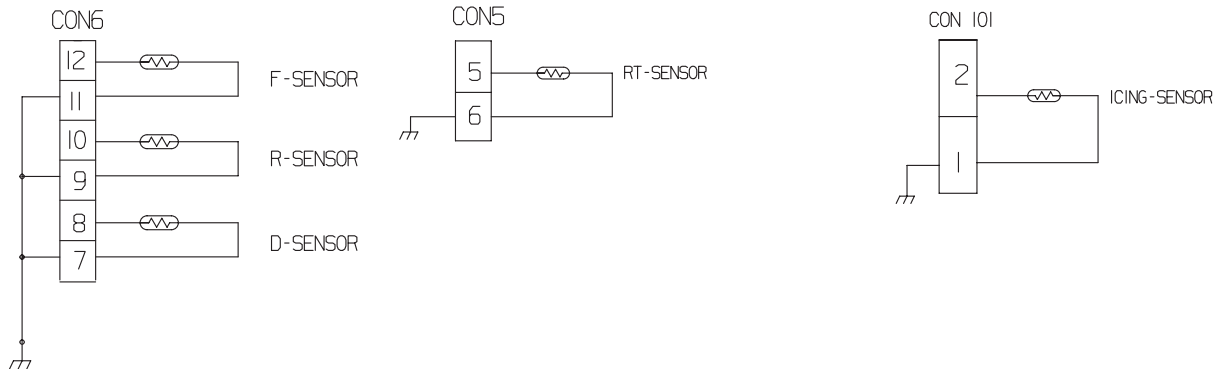

TEMPERATURE	RESISTANCE OF FREEZER/Icing SENSOR	RESISTANCE OF REFRIGERATOR & DEFROST SENSOR & ROOM SENSOR
- 20 °C (-4 °F)	22.3 KΩ	77 KΩ
- 15 °C (5 °F)	16.9 KΩ	60 KΩ
- 10 °C (14 °F)	13.0 KΩ	47.3 KΩ
- 5 °C (23 °F)	10.1 KΩ	38.4 KΩ
0 °C (32 °F)	7.8 KΩ	30 KΩ
+ 5 °C (41 °F)	6.2 KΩ	24.1 KΩ
+ 10 °C (50 °F)	4.9 KΩ	19.5 KΩ
+ 15 °C (59 °F)	3.9 KΩ	15.9 KΩ
+ 20 °C (68 °F)	3.1 KΩ	13 KΩ
+ 25 °C (77 °F)	2.5 KΩ	11 KΩ
+ 30 °C (86 °F)	2.0 KΩ	8.9 KΩ
+ 40 °C (104 °F)	1.4 KΩ	6.2 KΩ
+ 50 °C (122 °F)	0.8 KΩ	4.3 KΩ

- The resistance of the SENSOR has a ±5% common difference.
- Measure the resistance of the SENSOR after leaving it for over 3 minutes in the measuring temperature. This delay is necessary due to sensor response speed.

8-2-4 Refrigeration Compartment Stepping Motor Damper Circuit

A reversible DC motor is used to open and close the damper.
 To open the damper, push test button once.
 To close the damper, push test button twice.

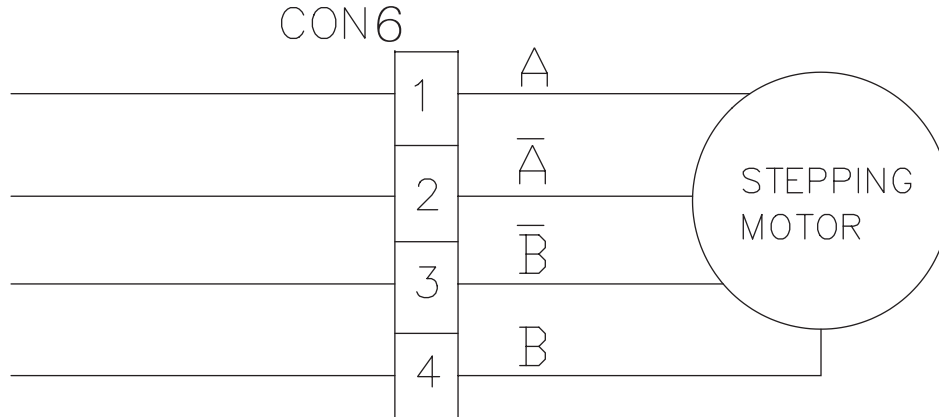

8-2-5 Dispenser Drive Circuit

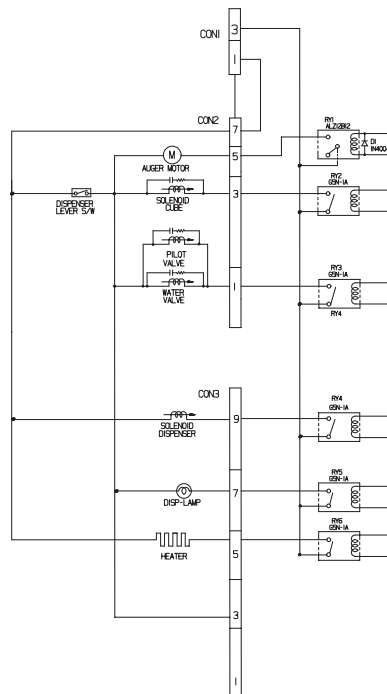

Circuit	Pin Number	Pin Number	Output Voltage
Auger Motor	Con2 Pin5	Con2 Pin7	115 VAC
Solenoid Cube	Con2 Pin3	Con2 Pin7	115 VAC
Pilot/ Water Valve	Con2 Pin1	Con2 Pin7	115 VAC
Solenoid Dispenser	Con3 Pin9	Con3 Pin3	115 VAC
Dispenser Lamp	Con3 Pin7	Con3 Pin3	115 VAC
Heater	Con3 Pin5	Con3 Pin3	115 VAC

8-3 TROUBLESHOOTING

PROBLEM	INDICATED BY	CHECK	CHECKING METHOD	CAUSE	SOLUTION
POWER SOURCE is poor.	1. The whole	1. FREEZER/ REFRIGERATOR.	Check if FREEZER/REFRIGERATOR DOOR IS OPEN and check display.	POWER SOURCE is poor.	Replace Main PWB
		2. If LAMP is dim.	Check visually.	Applied voltage error.	Replace Main PWB
	2. DISPLAY LED	3. The connection of the MAIN PWB CONNECTOR.	Check connection of CONNECTOR.	CONNECTOR connection is poor.	Reconnect CONNECTOR
				TRANS FUSE is open.	Replace Main PWB
COOLING is poor.	NO COOLING.	1. If the COMPRESSOR operate.	USE TEST MODE1 (forced COOLING). If less than 7 minutes pass after compressor shuts off, don't press the KEY and wait.	COMPRESSOR locked or blocked.	Replace OLP, PTC.
				OLP, PTC is poor. COMPRESSOR RELAY is poor.	Replace MAIN PWB.
				THE CONNECTING WIRE is poor.	Check the connection of the black wire of the MAIN PWB CONNECTOR (CON3).
		2. If refrigerant is leaking.	Measure the amount of frost sticking on EVAPORATOR and the surface temperature of the condenser pipe.	Refrigerant leakage.	Replace the leaking part and replace any lost refrigerant.
	FREEZER TEMPERATURE is incorrect	1. If FAN MOTOR operates.	USE TEST MODE1 (forced COOLING).	FAN MOTOR is poor.	Replace the FAN MOTOR.
				CONNECTING WIRE is poor.	Certify the MOTOR and the connection of the wire of the MAIN PWB CONNECTOR (CON4). See DEFROSTING is poor.
		2. If DEFROSTING is normal.	Check the amount of frost sticking on the EVAPORATOR .	DEFROSTING is poor.	Replace SENSOR.
		3. If SENSOR is normal.	of the Refrigerator SENSOR.	SENSOR RESISTANCE is poor.	Replace door liner.
		4. Door Line contact.	Check the seal when the door is closed.	Door liner damaged.	

PROBLEM	INDICATED BY	CHECK	CHECKING METHOD	CAUSE	SOLUTION
COOLING is poor.	If REFRIGERATOR TEMPERATURE is too low.	1. If FREEZER TEMPERATURE is normal.	Check is FREEZER TEMPERATURE is too low.		Make sure the DOOR is attached.
		2. If amount of cool air from FAN MOTOR is sufficient.	Make sure that the amount and speed of cool air are sufficient by touching the check supplied on the REFRIGERATOR.	FAN MOTOR is poor.	Replace FAN MOTOR.
				Passage of cool air is blocked.	Remove impurities.
		3. Door Line contact.	Check door seal when door is closed.	EVA frozen.	See DEFROSTING is poor.
Door liner damaged.	Replace Door liner.				
DEFROSTING is poor.	NO DEFROSTING.	1. If HEATER emits heat.	USE TEST MODE3 (forced DEFROSTING).	HEATER disconnection.	Replace HEATER.
				TEMPERATURE FUSE disconnection.	Replace TEMPERATURE FUSE.
				Connection is poor.	Check EVAPORATOR connection and wire of MAIN PWB CONNECTOR.
				DEFROST-SENSOR is poor.	Replace DEFROST-SENSOR.
				HEATER RELAY is poor.	Replace RY4 of MAIN PWB.
		2. If DRAIN PIPE is blocked.	Check DRAIN PIPE.	DRAIN PIPE is blocked.	Remove ice and impurities.
					Check HEATER PLATE resistance.
		3. If ice remains after DEFROSTING.	Make sure that DEFROST SENSOR is connected.	Connection is poor.	Reassemble the DEFROST-SENSOR.
Make sure that FREEZER /REFRIGERATOR DOOR is closed.	DOOR does not close properly.				Reassemble DOOR. Replace GASKET.

8-4 MAIN PWB ASSEMBLY AND PARTS LIST

8-4-1 Main PWB Assembly

Only when program is changed, this connector7 must be used for downloading program to be changed.

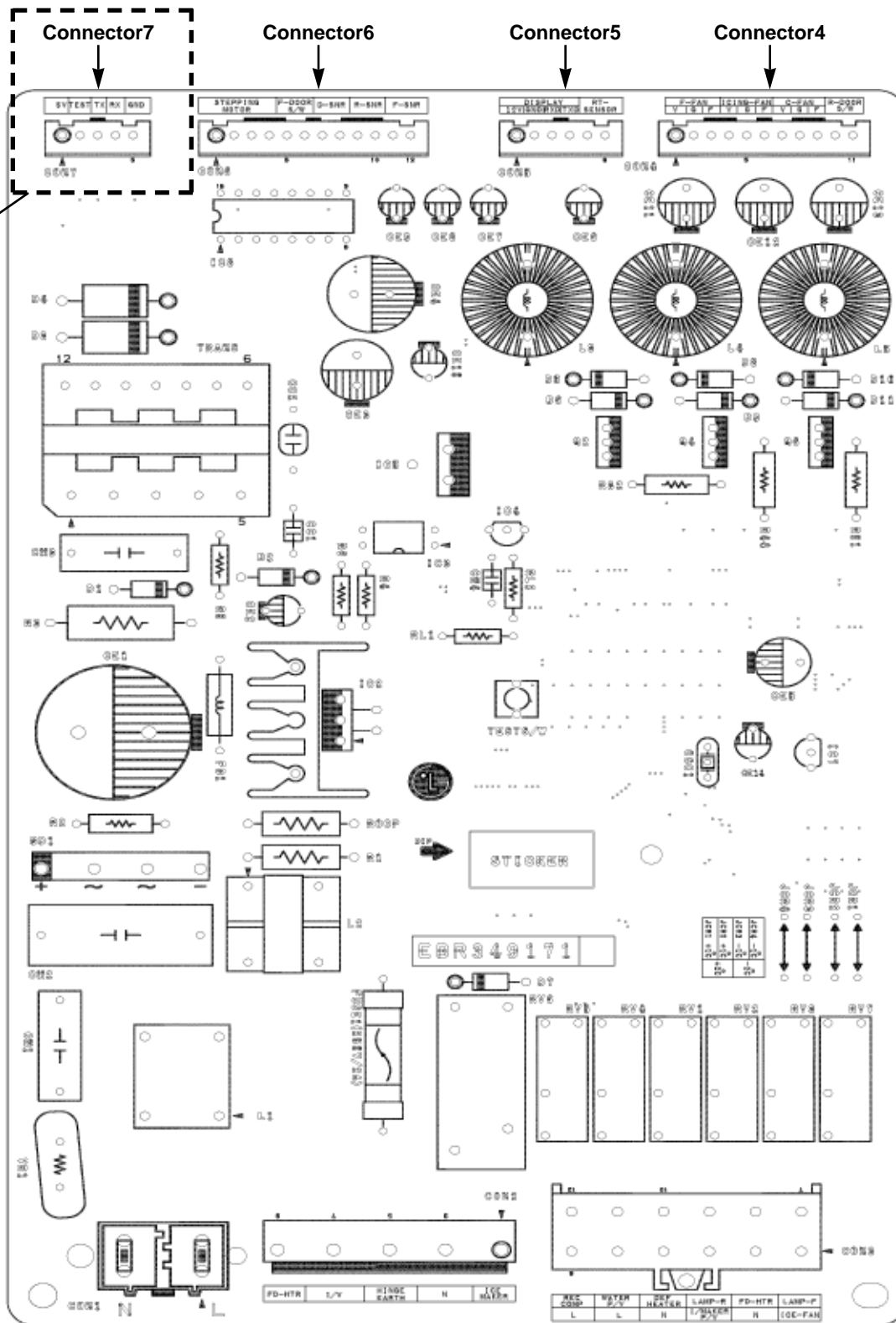

Connector1

Connector2

Connector3

8-4-2 Dispenser Drive PWB Assembly

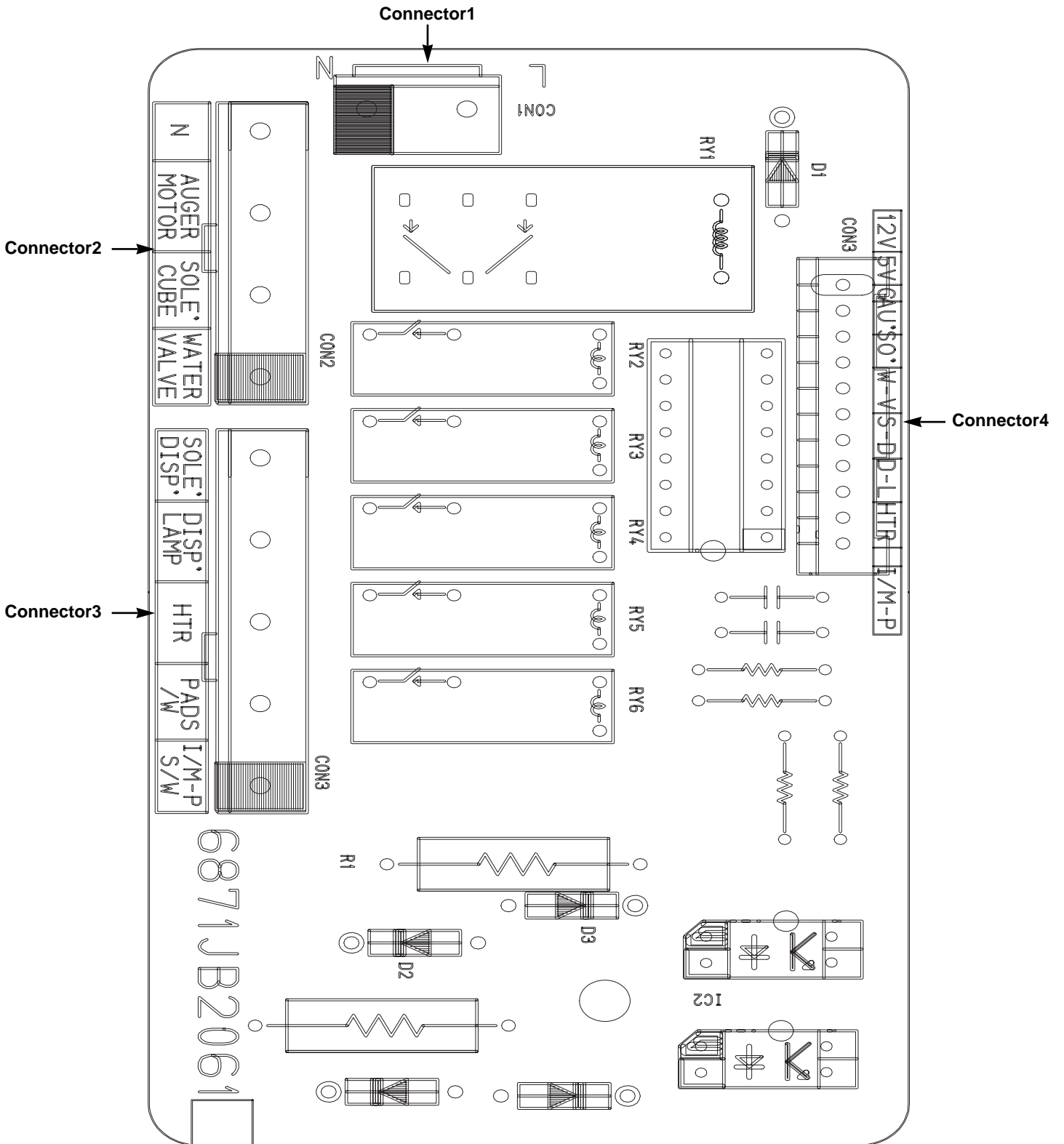



REPAIR PARTS LIST

MODELS No.

- 795.78502800
- 795.78503800
- 795.78506800
- 795.78509800
- 795.78512800
- 795.78513800
- 795.78516800
- 795.78519800

The model number of your refrigerator is found on the serial plate inside.

All repair parts listed are available for immediate purchase or special order when you visit your nearest Sears Service Center, or the Service Department at most Sears stores. To order parts by phone, call the toll free parts number listed to the left.

When requesting service or ordering parts, always provide the following information:

- Product Type • Part Number
- Model Number • Part Description

To call Toll Free For Parts:

1-800-366-PART
(1-800-366-7278)

For Service:

1-800-4-MY-HOME
(1-800-469-4663)

Last Revision: March. 10. 2008

Sears, Roebuck and Co., Hoffman Estates, IL 60179 U.S.A.

Get it fixed, at your home or ours!

Your Home

For repair—in your home—of all major brand appliances, lawn and garden equipment, or heating and cooling systems, **no matter who made it, no matter who sold it!**

For the replacement parts, accessories and owner's manuals that you need to do-it-yourself.

For Sears professional installation of home appliances and items like garage door openers and water heaters.

1-800-4-MY-HOME® (1-800-469-4663)

Call anytime, day or night (U.S.A. and Canada)

www.sears.com www.sears.ca

Our Home

For repair of carry-in items like vacuums, lawn equipment, and electronics, call or go on-line for the location of your nearest

Sears Parts & Repair Center.

1-800-488-1222

Call anytime, day or night (U.S.A. only)

www.sears.com

To purchase a protection agreement (U.S.A.) or maintenance agreement (Canada) on a product serviced by Sears:

1-800-827-6655 (U.S.A.)

1-800-361-6665 (Canada)

Para pedir servicio de reparación a domicilio, y para ordenar piezas:

1-888-SU-HOGARSM
(1-888-784-6427)

Au Canada pour service en français:

1-800-LE-FOYERSM
(1-888-533-6937)
www.sears.ca



® Registered Trademark /™ Trademark /SM Service Mark of Sears, Roebuck and Co.
® Marca Registrada /™ Marca de Fábrica /SM Marca de Servicio de Sears, Roebuck and Co.
™ Marque de commerce /M Marque déposée de Sears, Roebuck and Co.

© Sears, Roebuck and Co.

VALVE & WATER TUBE PARTS

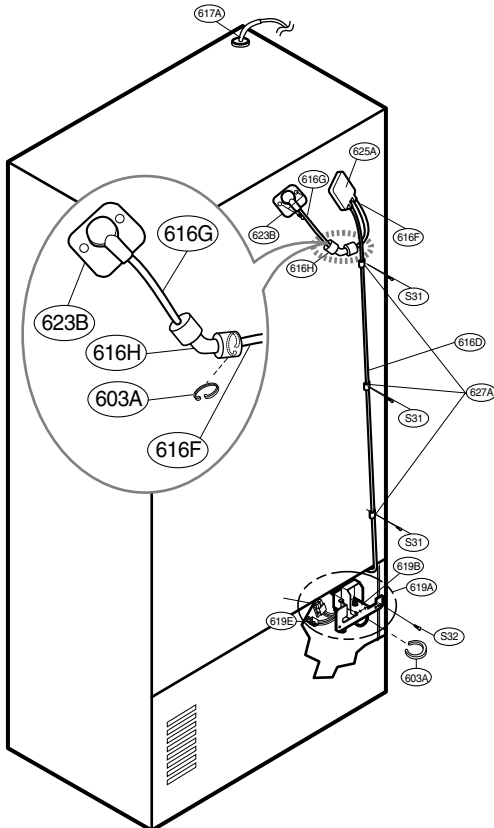

LOC No.	775**	Description
603A	4004JA3002A	Clip
603D	4930JA3091A	Holder, Bracket
616D	5210JA3005L	Tube, Plastic
616F	5210JA3004U	Tube, Plastic
616G	5210JA3005W	Tube, Plastic
616H	4932JA3009A	Connector, Tube
617A	4970JA3004N	Spring
619A	5220JB2009A	Valve, Water
619B	5220JB2008A	Valve, Water
619E	6877JB3036K	Drawing, Assembly
619E	6877JB3036M	Drawing, Assembly
623B	5006JJ2009A	Cap, Cover
625A	3550JA2184B	Cover, Tube
627A	4930JA3054A	Holder, Pipe S31
S31	4J00415D	Screw, Customized
S32	4000W4A003A	Screw, Customized

CAUTION: Use the part number to order part, not the location number.

CASE PARTS

CAUTION: Use the part number to order part, not the position number.

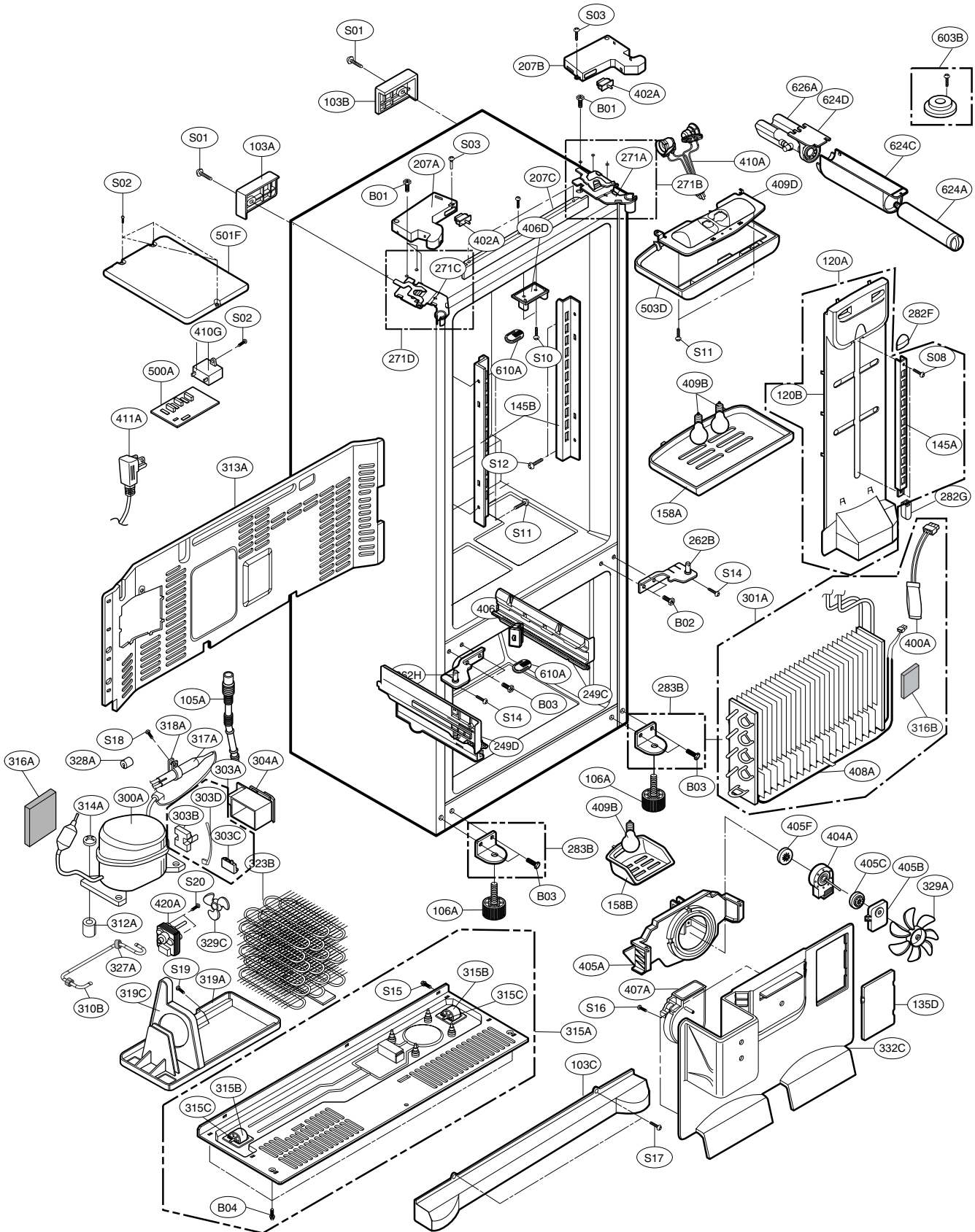

CASE PARTS

Loc No.	785*3(ST)	785*2(SW)	785*9(WB)	785*6(TI)	Description
103A	3650JA2061X	3650JA2061B	3650JA2113N	3650JA2061X	Handle, Rear
103B	3650JA2061W	3650JA2061	A 3650JA2113P	3650JA2061W	Handle, Rear
103C	3550JJ0008L	3550JJ0008A	3550JJ0008C	3550JJ0008L	Cover, Lower
105A	5251JA3003D	5251JA3003D	5251JA3003D	5251JA3003D	Tube Assembly, Drain
106A	4779JJ2001B	4779JJ2001B	4779JJ2001B	4779JJ2001B Leg	Leg Assembly, Adjust
120B	5208JA1156A	5208JA1156A	5208JA1156A	5208JA1156A	Duct, Multi
135D	3551JJ2028A	3551JJ2028A	3551JJ2028A	3551JJ2028A	Cover Assembly, Grille Fan
145A	4930JA2080C	4930JA2080C	4930JA2080C	4930JA2080C	Holder, Shelf
145B	4930JA2081C	4930JA2081C	4930JA2081C	4930JA2081C	Holder, Shelf
158A	3550JJ1070B	3550JJ1070B	3550JJ1070B	3550JJ1070B	Cover, Lamp
158B	3550JA1386B	3550JA1386B	3550JA1386B	3550JA1386B	Cover, Lamp
207A	3550JJ1097Q	3550JJ1097A	3550JJ1097E	3550JJ1097Q	Cover, Hinge
207B	3550JJ1097R	3550JJ1097B	3550JJ1097F	3550JJ1097R	Cover, Hinge
207C	3806JA2146E	3806JA2146A	3806JA2146C	3806JA2146E	Decor Assembly, Case
249C	MEG41697601	MEG41697601	MEG41697601	MEG41697601	Holder, Rail
249D	MEG41697602	MEG41697602	MEG41697602	MEG41697602	Holder, Rail
262B	AEH33724102	4775JJ2017B	4775JJ2017F	AEH33724102	Hinge Assembly, Center
262H	AEH33724104	4775JJ2017D	4775JJ2017H	AEH33724104	Hinge Assembly, Center
271C	4775JJ2014B	4775JJ2014B	4775JJ2014B	4775JJ2014B	Hinge Assembly, Upper
271B	4510JA3004A	4510JA3004A	4510JA3004A	4510JA3004A	Lever, Hinge
271A	4775JJ2014A	4775JJ2014A	4775JJ2014A	4775JJ2014A	Hinge Assembly, Upper
282F	3806JL1037G	3806JL1037G	3806JL1037G	3806JL1037G	Decor, Duct
282G	5006JA3111A	5006JA3111A	5006JA3111A	5006JA3111A	Cap, Duct
283B	4774JJ3002A	4774JJ3002A	4774JJ3002A	4774JJ3002A	Hinge, Lower
300A	TCA31748001	TCA31748001	TCA31748001	TCA31748001	Compressor, Set Assembly
301A	5421JJ1003B	5421JJ1003B	5421JJ1003B	5421JJ1003B	Evaporator Assembly
303A	EBG31940225	EBG31940225	EBG31940225	EBG31940225	Thermistor Assembly, PTC
303B	6748C-0004D	6748C-0004D	6748C-0004D	6748C-0004D	Thermistor Assembly, PTC
303C	6750C-0004R	6750C-0004R	6750C-0004R	6750C-0004R	Overload Protect
303D	6877JB2051F	6877JB2051F	6877JB2051F	6877JB2051F	Drawing, Assembly
304A	3550JA2042C	3550JA2042C	3550JA2042C	3550JA2042C	Cover, PTC
310B	4J00977P	4J00977P	4J00977P	4J00977P	Pipe, Compressor Sealing
312A	5040JA3071A	5040JA3071A	5040JA3071A	5040JA3071A	Damper, Compressor
313A	3551JJ2018A	3551JJ2018A	3551JJ2018A	3551JJ2018A	Cover Assembly, Machinery(Rear)
314A	4620JA3015A	4620JA3015A	4620JA3015A	4620JA3015A	Stopper, Compressor
315A	3103JJ1001H	3103JJ1001H	3103JJ1001H	3103JJ1001H	Base Assembly, Compressor
315B	4580JJ3001A	4580JJ3001A	4580JJ3001A	4580JJ3001A	Roller
315C	1PZZJA3013B	1PZZJA3013B	1PZZJA3013B	1PZZJA3013B	Pin, Common
316A	5072JA3003F	5072JA3003F	5072JA3003F	5072JA3003F	Damper, Noise
316B	5072JA3003B	5072JA3003B	5072JA3003B	5072JA3003B	Damper, Noise
317A	5851JA2008U	5851JA2008U	5851JA2008U	5851JA2008U	Drier Assembly
318A	4930JA3034A	4930JA3034A	4930JA3034A	4930JA3034A	Holder, Drier
319A	MJS37355401	MJS37355401	MJS37355401	MJS37355401	Tray, Drip
319C	MEA42257901	MEA42257901	MEA42257901	MEA42257901	Guide, Fan
323B	ACG36653801	ACG36653801	ACG36653801	ACG36653801	Condenser Assembly, Wire
327A	4J03020A	5040JA3056A	5040JA3056A	5040JA3056A	Damper, Pipe
329A	5901JA1021A	5901JA1021A	5901JA1021A	5901JA1021A	Fan Assembly
329C	ADP36665701	ADP36665701	ADP36665701	ADP36665701	Fan Assembly
332C	AEB34270102	AEB34270102	AEB34270102	AEB34270102	Grille Assembly, Fan
400A	6615JB2005H	6615JB2005H	6615JB2005H	6615JB2005H	Controller Assembly
402A	6600JB3007B	6600JB3007A	6600JB3007E	6600JB3007B	Switch, Push Button
402C	6600JB3001E	6600JB3001E	6600JB3001E	6600JB3001E	Switch, Micro
404A	4681JK1004E	4681JK1004E	4681JK1004E	4681JK1004E	Motor, DC
405B	4810JJ2005A	4810JJ2005A	4810JJ2005A	4810JJ2005A	Bracket, Motor
405C	5040JA2009B	5040JA2009B	5040JA2009B	5040JA2009B	Damper, Motor Support
405F	5040JA2004B	5040JA2004B	5040JA2004B	5040JA2004B	Damper, Motor Support
406B	6600JB1010A	6600JB1010A	6600JB1010A	6600JB1010A	Switch, Push Button

CAUTION: Use the part number to order part, not the position number.

CASE PARTS

LOC No.	785*3(ST)	785*2(SW)	785*9(WB)	755*6(I)	Description
406D	4931JA3006A	4931JA3006A	4931JA3006A	4931JA3006A	Holder Assembly, Gasket
407A	5209JA1044A	5209JA1044A	5209JA1044A	5209JA1044A	Duct Assembly, Connector
407B	4810JJ0003A	4810JJ0003A	4810JJ0003A	4810JJ0003A	Bracket, Motor
408A	5300JK1005D	5300JK1005D	5300JK1005D	5300JK1005D	Heater, Sheath
409B	6912JB2004K	6912JB2004K	6912JB2004K	6912JB2004K	Lamp, Incandescent
409D	3034JA1009A	3034JA1009A	3034JA1009A	3034JA1009A	Reflector, Lamp
410A	6621JK2003B	6621JK2003B	6621JK2003B	6621JK2003B	Drawing, Assembly
410G	0CZZJB2012K	0CZZJB2012K	0CZZJB2012K	0CZZJB2012K	Capacitor, Electric Appliance Film,Box
411A	6411JB1042L	6411JB1042L	6411JB1042L	6411JB1042L	Power Cord Assembly
420A	4681JB1029D	4681JB1029D	4681JB1029D	4681JB1029D	DC Motor Assembly
500A	EBR41956403	6871JB1411J	6871JB1411J	6871JB1411J	PCB Assembly
501F	3551JA2144C	3551JA2144C	3551JA2144C	3551JA2144C	Cover Assembly, PCB
503D	3110JJ1014A	3110JJ1014A	3110JJ1014A	3110JJ1014A	Case, Lamp
603B	4930JA3091A	4930JA3091A	4930JA3091A	4930JA3091A	Holder, Bracket
610A	3550JA2247A	3550JA2247A	3550JA2247A	3550JA2247A	Cover, Sensor
624A	5231JA2006A	5231JA2006A	5231JA2006A	5231JA2006A	Filter Assembly, Water
624C	3550JD1128D	3550JD1128D	3550JD1128D	3550JD1128D	Cover, Filter
624D	5230JA2003A	5230JA2003A	5230JA2003A	5230JA2003A	Filter, Head
626A	3550JA2279A	3550JA2279A	3550JA2279A	3550JA2279A	Cover, Filter
B02	1STZJA3004Q	1STZJA3004Q	1STZJA3004D	1STZJA3004Q	Screw, Customzied
B03	1STZJA3004F	1STZJA3004F	1STZJA3004F	1STZJA3004F	Screw, Customzied
B04	1BZZJA2002A	1BZZJA2002A	1BZZJA2002A	1BZZJA2002A	Bolt, Common
S01	4J00415D	4J00415D	4J00415D	4J00415D	Screw, Customzied
S02	4J00415D	4J00415D	4J00415D	4J00415D	Screw, Customzied
S03	4J01424B	4J01424B	4J01424B	4J01424B	Screw, Customzied
S08	1SZZJJ3005E	1SZZJJ3005E	1SZZJJ3005E	1SZZJJ3005E	Screw, Customzied
S09	4J00415D	4J00415D	4J00415D	4J00415D	Screw, Customzied
S10	1SBZJA3004L	1SBZJA3004L	1SBZJA3004L	1SBZJA3004L	Screw, Customzied
S11	3J05696W	3J05696W	3J05696W	3J05696W	Screw, Customzied
S13	1SZZJJ3005E	1SZZJJ3005E	1SZZJJ3005E	1SZZJJ3005E	Screw, Customzied
S14	1SZZJJ3010D	1SZZJJ3010D	1SZZJJ3010B	1SZZJJ3010D	Screw, Customzied
S15	4000W4A003A	4000W4A003A	4000W4A003A	4000W4A003A	Screw, Customzied
S16	3J05696W	3J05696W	3J05696W	3J05696W	Screw, Customzied
S17	1SZZJA3005H	1SZZJA3005H	1SZZJA3005H	1SZZJA3005H	Screw, Customzied
S18	4J00415D	4J00415D	4J00415D	4J00415D	Screw, Customzied
S19	4J00415D	4J00415D	4J00415D	4J00415D	Screw, Customzied
S20	1SZZJA3016A	1SZZJA3016A	1SZZJA3016A	1SZZJA3016A	Screw, Customzied

CAUTION: Use the part number to order part, not the position number.

FREEZER PARTS

CAUTION: Use the part number to order part, not the position number.

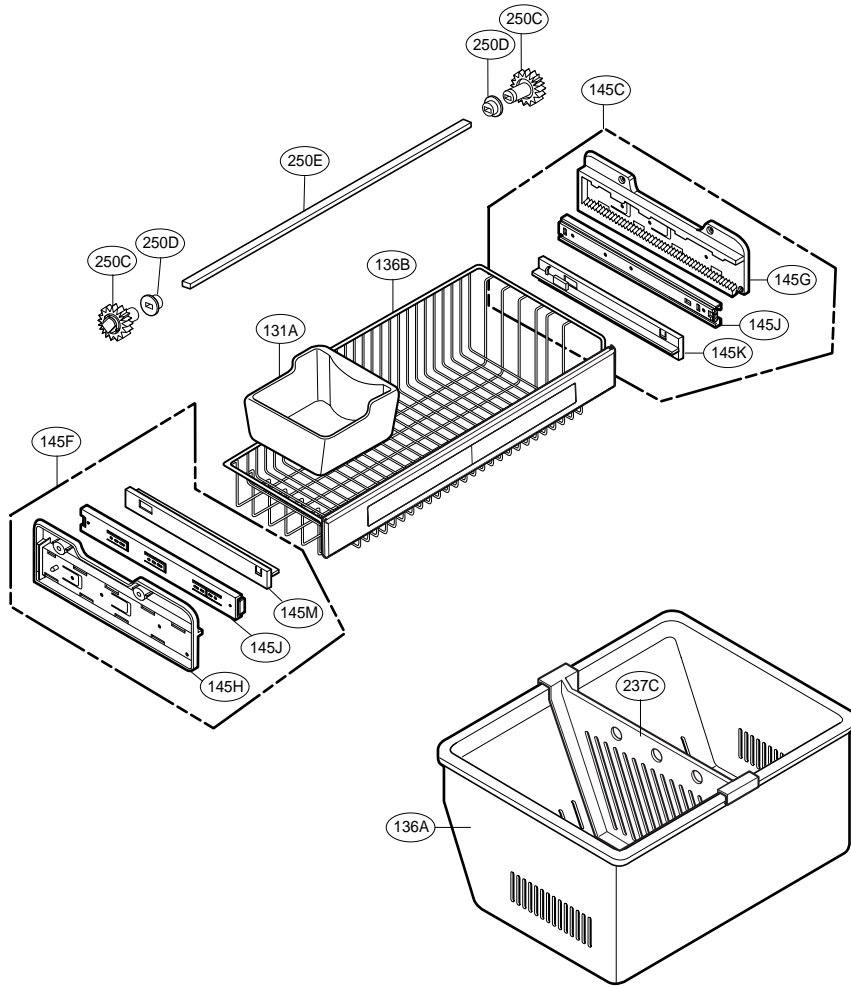

LOC No.	785*3(ST)	785*2(SW)	785*9(WB)	785*6(TI)	Description
131A	5074JA2004A	5074JA2004A	5074JA2004A	5074JA2004A	Bucket, Ice
136A	3390JJ1072A	3390JJ1072A	3390JJ1072A	3390JJ1072A	Tray, Drawer
136B	3391JA2054M	3391JA2054M	3391JA2054M	3391JA2054M	Tray Assembly, Drawer
145C	4975JA1040B	4975JA1040B	4975JA1040B	4975JA1040B	Guide Assembly, Rail
145F	4975JA1040A	4975JA1040A	4975JA1040A	4975JA1040A	Guide Assembly, Rail
237C	4974JJ1031A	4974JJ1031A	4974JJ1031A	4974JJ1031A	Guide, Drawer
250C	4470JA2008A	4470JA2008A	4470JA2008A	4470JA2008A	Gear, Ice
250D	5006JA2069A	5006JA2069A	5006JA2069A	5006JA2069A	Cap, Cover
250E	MAK36519001	MAK36519001	MAK36519001	MAK36519001	Bar

CAUTION: Use the part number to order part, not the position number.

REFRIGERATOR PARTS

CAUTION: Use the part number to order part, not the position number.

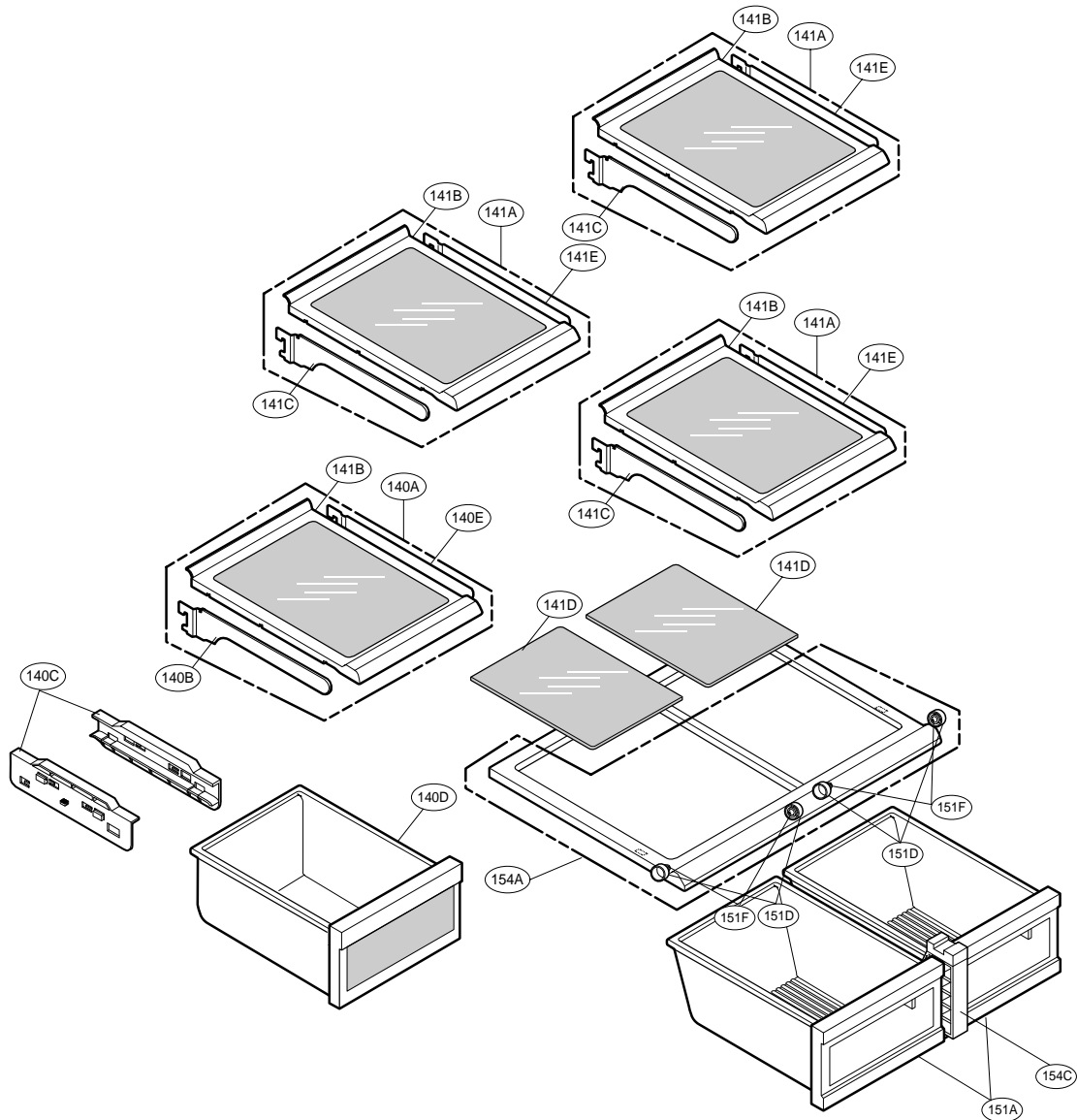

LOC No.	785*3(ST)	785*2(SW)	785*9(WB)	785*6(TI)	Description
140A	AHT33055806	AHT33055806	AHT33055806	AHT33055806	Shelf Assembly, Refrigerator
140B	5026JJ2012C	5026JJ2012C	5026JJ2012C	5026JJ2012C	Shelf, Net
140C	4975JA2028A	4975JA2028A	4975JA2028A	4975JA2028A	Guide Assembly, Rail
140D	AHT33056304	AHT33056304	AHT33056304	AHT33056304	Shelf Assembly, Refrigerator
141A	AHT33055805	AHT33055805	AHT33055805	AHT33055805	Shelf Assembly, Refrigerator
141B	MHL47278101	MHL47278101	MHL47278101	MHL47278101	Shelf, Refrigerator
141C	5026JA2052B	5026JA2052B	5026JA2052B	5026JA2052B	Shelf, Net
141D	MCK49483302	MCK49483302	MCK49483302	MCK49483302	Cover, Glass
151A	AJP32871402	AJP32871402	AJP32871402	AJP32871402	Tray Assembly, Vegetable
151C	1SZZJA3011B	1SZZJA3011B	1SZZJA3011B	1SZZJA3011B	Screw, Customized
151D	4580JA3042A	4580JA3042A	4580JA3042A	4580JA3042A	Roller
151F	1SZZJA3011B	1SZZJA3011B	1SZZJA3011B	1SZZJA3011B	Screw, Customized
154A	3551JJ2020G	3551JJ2020H	3551JJ2020H	3551JJ2020H	Cover Assembly, TV
154C	4980JA2092A	4980JA2092A	4980JA2092A	4980JA2092A	Supporter, Cover TV

CAUTION: Use the part number to order part, not the position number.

DOOR PARTS

CAUTION: Use the part number to order part, not the position number.

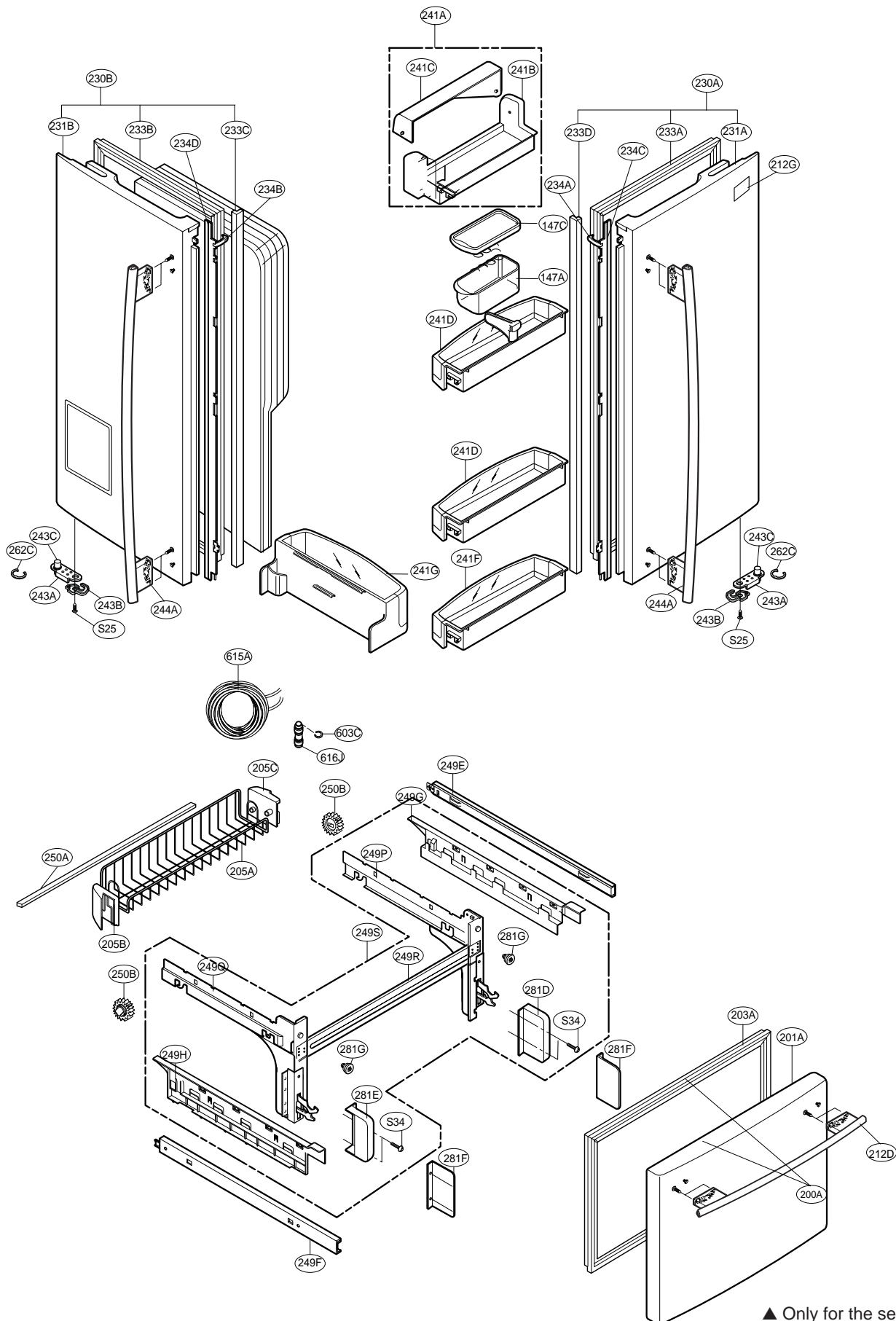

▲ Only for the service

DOOR PARTS

LOCNo.	785*3(ST)	785*2(SW)	785*9(WB)	785*6(TI)	Description
147A	5074JJ1016A	5074JJ1016A	5074JJ1016A	5074JJ1016A	Bucket, Dairy
147C	3550JJ1084A	3550JJ1084A	3550JJ1084A	3550JJ1084A	Cover, Bucket
200A	ADC55707302	ADC55707304	ADC55707305	ADC55707303	Door Assembly, Freezer
201A	5433JA8558K	ADD55708302	5433JA8558L	ADD57015501	Door Foam Assembly, Freezer
203A	MDS38201406	MDS38201401	MDS38201402	MDS38201406	Gasket, Door
205A	5004JJ1061B	5004JJ1061B	5004JJ1061B	5004JJ1061B	Basket, Door
205B	5004JA2017A	5004JA2017A	5004JA2017A	5004JA2017A	Basket, Tilt
205C	5004JA2017B	5004JA2017B	5004JA2017B	5004JA2017B	Basket, Tilt
212D	AED37133505	AED37133507	AED37133506	AED37133505	Handle Assembly, Freezer
212G	4140JD1031A	4140JD1031A	4140JD1031A	4140JD1031A	Name Plate
230A	ADC57016101	ADC57016901	ADC57016902	ADC57016801	Door Assembly, Refrigerator(Right)
231A	ADD57016001	ADD57017101	ADD57017102	ADD57017001	Door Foam Assembly, Refrigerator
230B	ADC57016301	ADC57017301	ADC57017302	ADC57017201	Door Assembly, Refrigerator(Left)
231B	ADD57016201	ADD57017501	ADD57017502	ADD57017401	Door Foam Assembly, Refrigerator
233A	4987JJ2002E	4987JJ2002A	4987JJ2002C	4987JJ2002E	Gasket Assembly, Door
233B	4987JJ1005F	4987JJ2002B	4987JJ2002D	4987JJ2002F	Gasket Assembly, Door
233C	3551JJ2030B	3551JJ2030A	3551JJ2030A	3551JJ2030B	Cover Assembly, Front
233D	3551JJ2030A	3551JJ2030B	3551JJ2030B	3551JJ2030A	Cover Assembly, Front
234A	4430JJ2004A	4430JJ2004A	4430JJ2004A	4430JJ2004A	Cam, Shaft
234C	4931JJ2002E	4931JJ2002A	4931JJ2002C	4931JJ2002E	Holder Assembly, Gasket
234D	4931JJ2002F	4931JJ2002B	4931JJ2002D	4931JJ2002F	Holder Assembly, Gasket
234B	4430JJ2004B	4430JJ2004B	4430JJ2004B	4430JJ2004B	Cam, Shaft
241A	AAP33686304	AAP33686304	AAP33686304	AAP33686304	Basket Assembly, Door
241B	MAN39723203	MAN39723203	MAN39723203	MAN39723203	Basket, Window
241C	MAN38142901	MAN38142901	MAN38142901	MAN38142901	Basket, Door
241D	AAP36817401	AAP36817401	AAP36817401	AAP36817401	problem in part no
241F	AAP36817601	AAP36817601	AAP36817601	AAP36817601	Basket Assembly, Door
241G	AAP33726608	AAP33726608	AAP33726608	AAP33726608	Basket Assembly, Door
243A	4620JJ3006D	4620JJ3006A	4620JJ3006C	4620JJ3006D	Stopper, Door
243B	4620JJ2009A	4620JJ2009A	4620JJ2009A	4620JJ2009A	Stopper, Door
243C	J326-00012A	J326-00012A	J326-00012A	J326-00012A	Bush
244A	AED37133301	AED37133303	AED37133302	AED37133301	Handle Assembly, Refrigerator
249E	5218JA1010J	5218JA1010J	5218JA1010J	5218JA1010J	Rail, Slide
249F	5218JA1010K	5218JA1010K	5218JA1010K	5218JA1010K	Rail, Slide
249S	ACJ36695103	ACJ36695103	ACJ36695103	ACJ36695103	Connector Assembly
262C	4350JA3005B	4350JA3005B	4350JA3005B	4350JA3005B	Ring
281D	3550JA2267B	3550JA2267B	3550JA2267B	3550JA2267B	Cover, Hinge
281E	3550JA2267A	3550JA2267A	3550JA2267A	3550JA2267A	Cover, Hinge
281F	3550JA2264A	3550JA2264A	3550JA2264A	3550JA2264A	Cover, Hinge
281G	MCQ42969201	MCQ42969201	MCQ42969201	MCQ42969201	Damper, Pipe
603C	4004JA3002A	4004JA3002A	4004JA3002A	4004JA3002A	Clip
615A	4838JA2003B	4838JA2003B	4838JA2003B	4838JA2003B	Tank, Water
616J	MCD38280801	MCD38280801	MCD38280801	MCD38280801	Connector, Tube

CAUTION: Use the part number to order part, not the position number.

DISPENSER PARTS

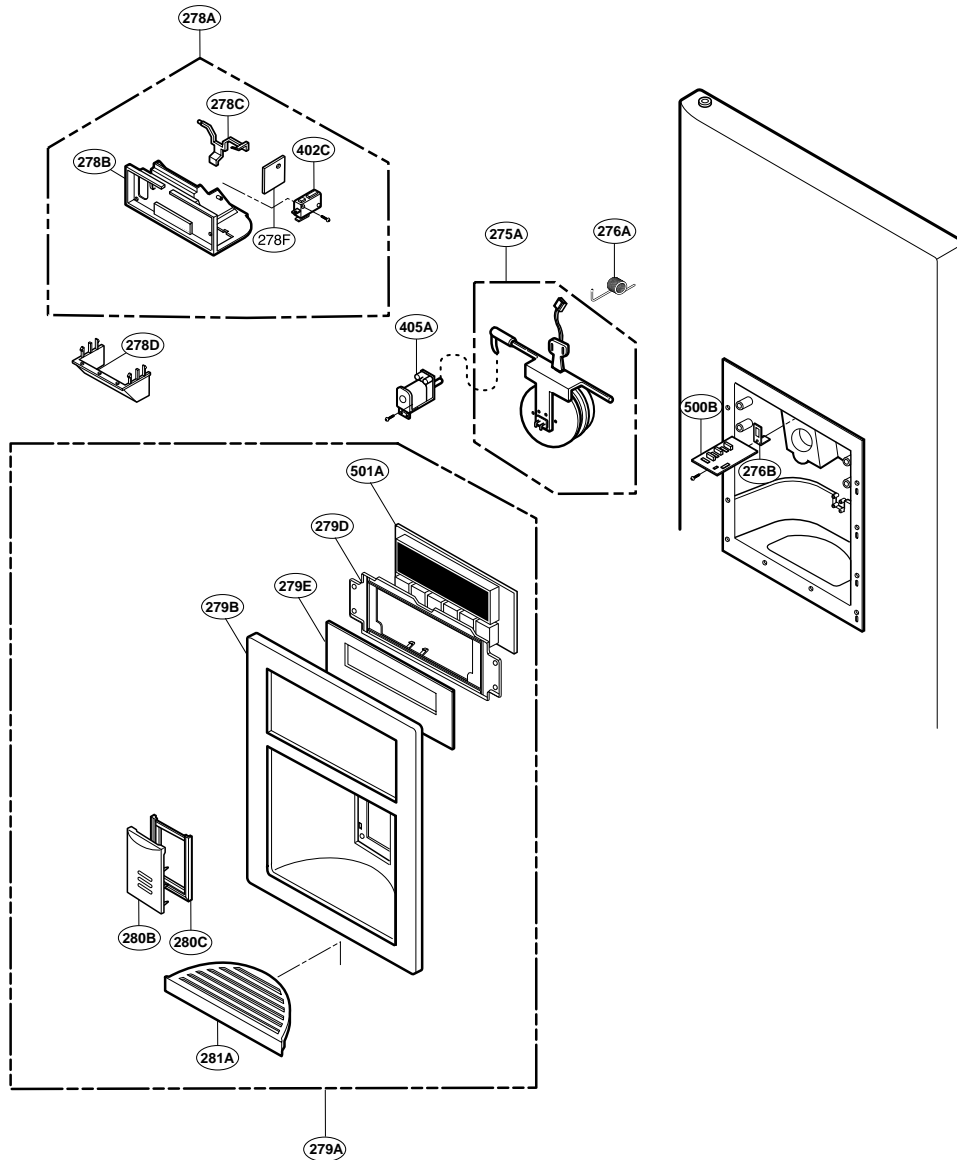

LOCNo.	785*3(ST)	785*2(SW)	785*9(WB)	785*6(TI)	Description
275A	5007JA3006R	5007JA3006R	5007JA3006R	5007JA3006R	Cap Assembly, Duct
276A	4970JA3011C	4970JA3011C	4970JA3011C	4970JA3011C	Spring, Lever
276B	4930JA3043A	4930JA3043A	4930JA3105A	4930JA3043A	Holder, Lever
278A	3017JA2008B	3017JA2008A	3017JA2008J	3017JA2008B	Funnel Assembly
278B	3210JA1072B	3210JA1072A	3210JA1072C	3210JA1072B	Frame, Funnel
278C	4510JA2022A	4510JA2022A	4510JA2027A	4510JA2022A	Lever, Dispenser
278D	3016JA2004E	3016JA2004A	3016JA2004C	3016JA2004E	Funnel
278F	6871JB2074A	6871JB2074A	6871JB2074A	6871JB2074A	PCB Assembly, Display
279A	ACQ37160701	ACQ37160702	ACQ37160703	ACQ37160701	Cover Assembly, Dispenser
279B	3550JA1468B	3550JA1468A	3550JA1468C	3550JA1468B	Cover, Dispenser
279D	MCK42378801	MCK42378801	MCK42378801	MCK42378801	Cover, Display
279E	MCR42758801	MCR42758803	MCR42758802	MCR42758801	Decor, Control
280B	4930JA2074B	4930JA2074B	4930JA2074B	4930JA2074B	Holder, Button
280C	5020JA2040E	5020JA2040F	5020JA2040K	5020JA2040E	Button, Lever
281A	3806JA2118B	3806JA2118A	3806JA2118C	3806JA2118B	Decor, Drain
402C	6600JB3001E	6600JB3001E	6600JB3001E	6600JB3001E	Switch, Micro
405A	6421JB2002D	6421JB2002D	6421JB2001M	6421JB2002D	Solenoid, Reversing, Valve
500B	6871JB2061B	6871JB2061B	6871JB2061B	6871JB2061B	PCB Assembly, Sub
501A	EBR43358501	EBR43358501	EBR43358501	EBR43358501	PCB Assembly, Display

ICE MAKER & ICE BANK PARTS

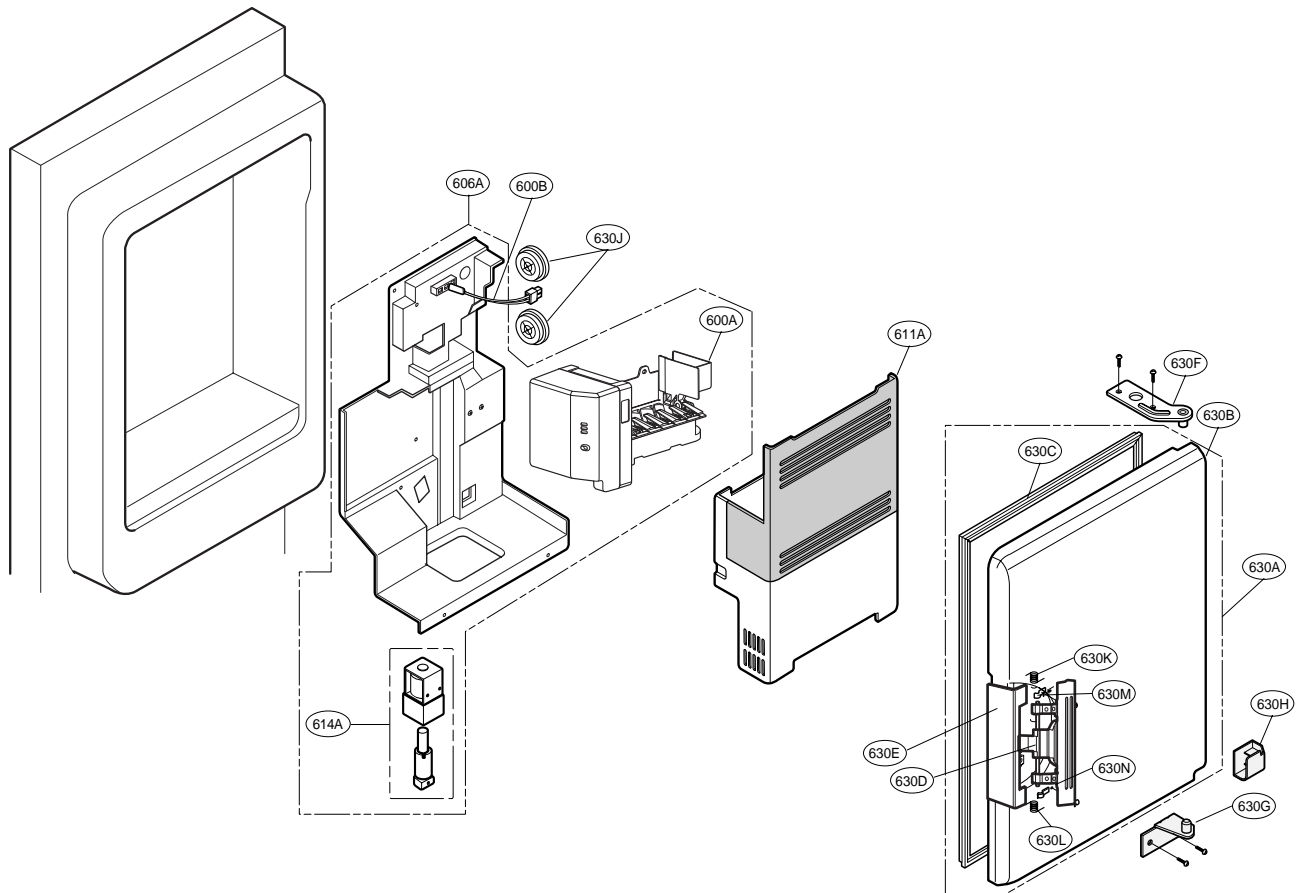

LOCNo.	785*3(ST)	785*2(SW)	785*9(WB)	785*6(TI)	Description
600A	AEQ36756901	AEQ36756901	AEQ36756901	AEQ36756901	Ice Maker Assembly, Kit
606A	4681JA1006D	4681JA1006D	4681JA1006D	4681JA1006D	Motor, AC
611A	5075JA1044G	5075JA1044G	5075JA1044G	5075JA1044G	Bucket Assembly, Ice
630A	ADC33751103	ADC33751103	ADC33751103	ADC33751103	Door Assembly, Freeze Room
630B	ADD33178703	ADD33178703	ADD33178703	ADD33178703	Door Foam Assembly
630C	4987JA2012B	4987JA2012B	4987JA2012B	4987JA2012B	Gasket Assembly, Door
630D	MEB49049003	MEB49049003	MEB49049003	MEB49049003	Handle, Home Bar
630E	MCR42600501	MCR42600501	MCR42600501	MCR42600501	Decor, Handle
630F	4775JA2101A	4775JA2101A	4775JA2101A	4775JA2101A	Hinge Assembly, Upper
630G	4775JA2102A	4775JA2102A	4775JA2102A	4775JA2102A	Hinge Assembly, Lower
630H	MCK38202501	MCK38202501	MCK38202501	MCK38202501	Cover, Home Bar
630J	4987JA3025A	4987JA3025A	4987JA3025A	4987JA3025A	Gasket Assembly, Door
630K	4970JA3044A	4970JA3044A	4970JA3044A	4970JA3044A	Spring
630L	4970JA3045A	4970JA3045A	4970JA3045A	4970JA3045A	Spring
630M	4860JA3010B	4860JA3010B	4860JA3010B	4860JA3010B	Clamp
630N	4860JA3010A	4860JA3010A	4860JA3010A	4860JA3010A	Clamp



*'You Can Count on me . . .
to Work Safely.'*