



Department 731A Toronto

TECHNICAL FLASH

T.F. 22-400



BASIC SERVICE MANUAL

FOR

MICROWAVE OVEN

MODEL 767. 8591000

767. 8591900

767. 8597000

FEBRUARY, 1999

CAUTION

SAFETY PRECAUTIONS

PRECAUTIONS TO BE OBSERVED BEFORE AND DURING SERVICING TO AVOID POSSIBLE EXPOSURE TO EXCESSIVE MICROWAVE ENERGY

- a. Do not operate or allow the oven to be operated with the door open.**
 - b. Make the following safety checks on all ovens to be serviced before activating the magnetron or other microwave source, and make repairs as necessary; (1) Interlock operation, (2) proper door closing, (3) seal and sealing surfaces (arcing, wear, and other damage), (4) damage to or loosening of hinges and latches, (5) evidence of dropping or abuse.**
 - c. Before turning on microwave power for any service test or inspection within the microwave generating compartments, check the magnetron, wave guide or transmission line, and cavity for proper alignment, integrity, and connections.**
 - d. Any defective or misadjusted components in the interlock, monitor, door seal, and microwave generation and transmission systems shall be repaired, replaced, or adjusted by procedures described in this manual before the oven is released to the owner.**
 - e. A Microwave leakage check to verify compliance with the CSA Standard should be performed on each oven prior to release to the owner.**
- Proper operation of the microwave ovens requires that the magnetron be assembled to the wave guide and cavity. Never operate the magnetron unless it is properly installed.
 - Be sure that the magnetron gasket is properly installed around the dome of the tube whenever installing the magnetron.
 - Routine service safety procedures should be exercised at all times.
 - Untrained personnel should not attempt service without a thorough review of the test procedures and safety information contained in this manual.

FOREWORD

Read this Manual carefully. Failure to adhere to or observe the information in this Manual may result in exposing yourself to the Microwave Energy normally contained within the oven cavity.

TABLE OF CONTENTS

	(Page)
SAFETY PRECAUTIONS	Inside front page
SPECIFICATIONS	1-1
CAUTIONS	2-1
INSTALLATIONS	3-1
OPERATING INSTRUCTIONS.....	4-1
CONTROL PANEL	4-1
CONTROL PANEL INSTRUCTIONS	4-2
OVERALL CIRCUIT DIAGRAM	5-1
SCHEMATIC DIAGRAM.....	5-1
MATRIX CIRCUIT FOR TOUCH KEY BOARD	5-2
GENERAL INFORMATION FOR SERVICE	6-1
GENERAL PRECAUTIONS IN USE	6-1
TRIAL OPERATION	6-1
FEATURES AND SPECIFICATIONS FEATURES.....	6-1
SERVICE INFORMATION	7-1
PRECAUTIONS AND REPAIR SERVICE TIPS.....	7-1
MICROWAVE LEAKAGE TEST	7-2
POWER OUTPUT MEASUREMENT	7-3
DISASSEMBLY INSTRUCTIONS	7-4
INTERLOCK SYSTEM	7-12
INTERLOCK CONTINUITY TEST.....	7-14
TEST AND CHECKOUT PROCEDURES AND TROUBLE SHOOTING.....	7-15
A. TEST PROCEDURES.....	7-15
B. CHECKOUT PROCEDURES.....	7-18
C. TROUBLE SHOOTING	7-21
EXPLODED VIEW	8-1
REPLACEMENT PARTS LIST	8-8
SCHEMATIC DIAGRAM OF PCB	8-17
PRINTED CIRCUIT BOARD	8-18
PCB PARTS LIST.....	8-19

SPECIFICATIONS

Rated Power Consumption	1,400W maximum (Microwave oven only) 1,500W maximum (Microwave oven+Cook top lamps+Ventilation fan)
Microwave Output	1000W (IEC 705 TEST PROCEDURE) Adjustable 100W through 1000W, 10 steps
Frequency	2,450 MHz \pm 50 MHz
Power Supply	120 VAC, 60 Hz
Rated Current	13 Amp. (Microwave oven only) 14 Amp. (Microwave oven+Cook top lamps+Ventilation fan)
Magnetron Cooling	Forced Air Cooling
Rectification	Rectification Voltage Double Half-Wave
Door Sealing	Choke System
Safety Devices	Magnetron Thermostat: Open at 150°C \pm 7°C (302°F \pm 44°F), short at 60°C \pm 15°C (140°F \pm 59°F) Oven Cavity Thermostat: Open at 110°C \pm 5°C (230°F \pm 41°F), short at 0°C (32°F) Fuse(20A) Primary Interlock Switch Secondary Interlock Switch Interlock Monitor
Magnetron	2M246-310GF or 2M248E
High Voltage Capacitor	Capacitor: 1.0 μ F, 2.1 KV AC
High Voltage Diode	Diode; 350mA, 9.0 KV
Cook top Lamp	125 V, 30 W
Cavity Lamp	125 V, 30 W or 40 W
Timer	Digital, up to 99 mim. 99 sec. (in each cooking stage)
Tray	Tempered Safety Glass
Overall Dimensions	29 ¹⁵ / ₁₆ " (W)x16 ⁷ / ₁₆ " (D)x15 ³ / ₈ " (H)
Oven Cavity Size	19 ⁷ / ₈ " (W)x14 ⁵ / ₃₂ " (D)x8 ¹⁵ / ₁₆ " (H)
Effective Capacity of Oven Cavity	1.5 Cu.ft.
Accessories	Owner's Manual & Cooking Guide, Installation Manual, Exhaust Adapter, Exhaust Damper, Mounting Kit and Two Filters, Rotating Ring Assembly.

CAUTIONS

Unlike other appliances, the microwave oven is high-voltage and high-current equipment. Though it is free from danger in ordinary use, extreme care should be taken during repair.

- DO NOT operate on a 2-wire extension cord during repair and use.
- NEVER TOUCH any oven components or wiring during operation.
- BEFORE TOUCHING any parts of the oven, always remove the power plug from the outlet.
- For about 30 seconds after the oven stops, an electric charge remains in the high voltage capacitor. When replacing or checking, you must discharge the high voltage capacitor by shorting across the two terminals with an insulated screwdriver.

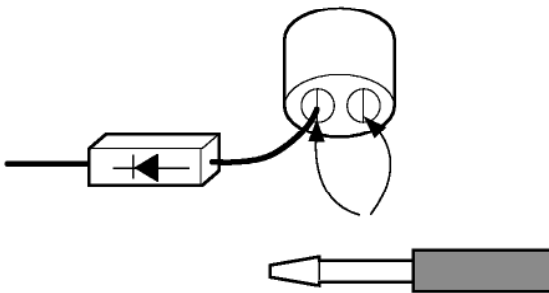

- Remove your watches whenever working close to or replacing the Magnetron.
- DO NOT touch any parts of the control panel circuit. A resulting static electric discharge may damage this P.C.B.
- NEVER operate the oven with no load.
- NEVER injure the door seal and front plate of the oven cavity.
- NEVER put iron tools on the magnetron.
- NEVER put anything into the latch hole and the interlock switches area.

MICROWAVE RADIATION

Personnel should not be exposed to the microwave energy which may radiate from the magnetron or other microwave generating device if it is improperly used or connection. All input and output microwave connections, waveguide, flange, and gasket must be secure never operate the device without a microwave energy absorbing load attached. Never look into an open waveguide or antenna while the device is energized.

- Proper operation of the microwave oven requires that the magnetron be assembled to the waveguide and cavity. Never operate the magnetron unless it is properly installed.
- **Be sure that the magnetron gasket is properly installed around the dome of the tube whenever installing the magnetron.**

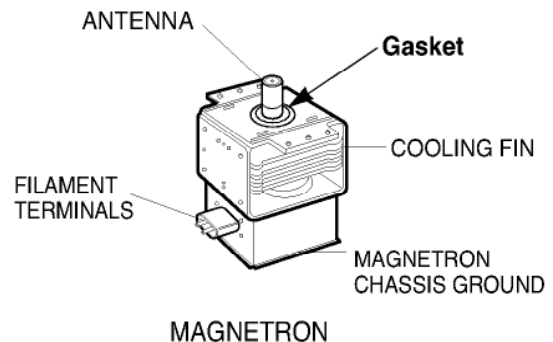

THE OVEN IS TO BE SERVICED ONLY BY PROPERLY QUALIFIED SERVICE PERSONNEL.

INSTALLATIONS

BEFORE YOU BEGIN, READ THE FOLLOWING INSTRUCTIONS COMPLETELY AND CAREFULLY.

PRECAUTIONS ON INSTALLATION

- A. Plug the power supply cord into a 120V AC, 60Hz, single-phase power source with a capacity of 15A or 20A.
- B. Avoid placing the unit in a location where there is direct heat or splashing water.
- C. Install the unit on the mounting plate firmly.
- D. Place the unit as far away as possible from TV, radio, etc. to prevent interference.

GROUNDING INSTRUCTIONS

For personal safety, this appliance must be fully grounded at all times.

In the event of an electrical short circuit, grounding reduces the risk of electrical shock.

The plug must be plugged into an outlet that is properly installed and grounded.

CAUTION

This unit is equipped with a 3-prong plug for your safety. If the wall outlet is a grounded 3-hole type, the unit will be grounded automatically.

Plug with Ground Prong

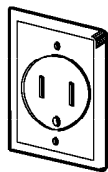
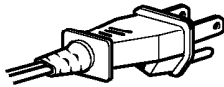

Properly Polarized and Grounded Outlet

WARNING

Improper use of the grounding plug can result in a risk of electric shock.

Do not, under any circumstances, cut or remove the third ground prong from the power cord plug.

OPERATING INSTRUCTIONS

CONTROL PANEL

FOR MODEL 85910, 85919

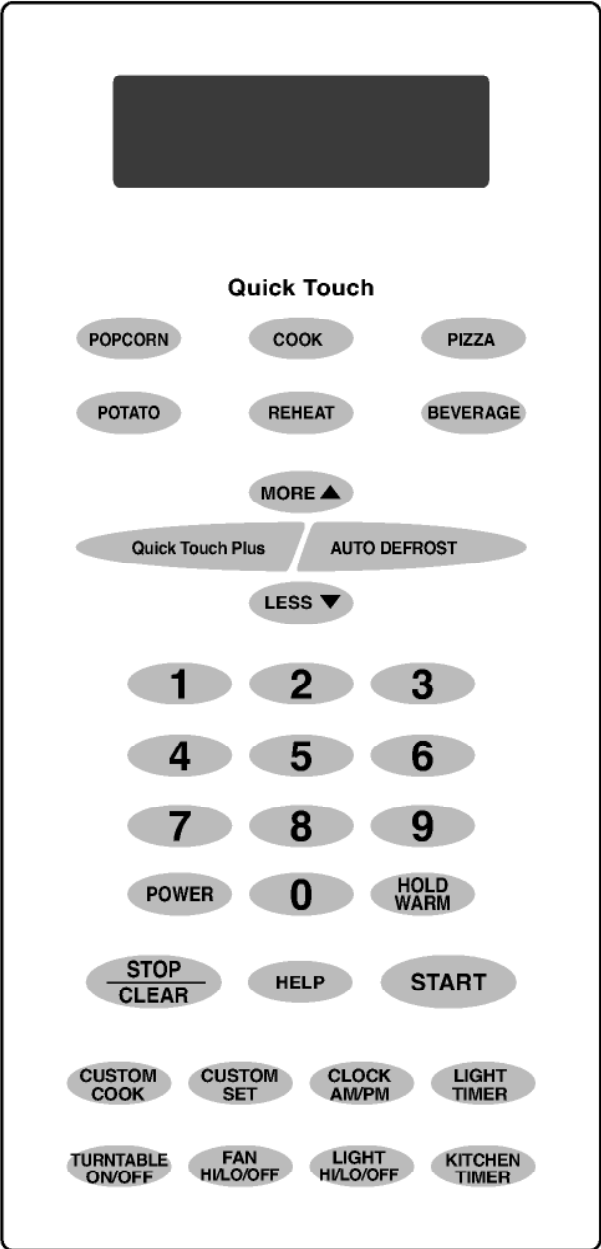

FOR MODEL 85970

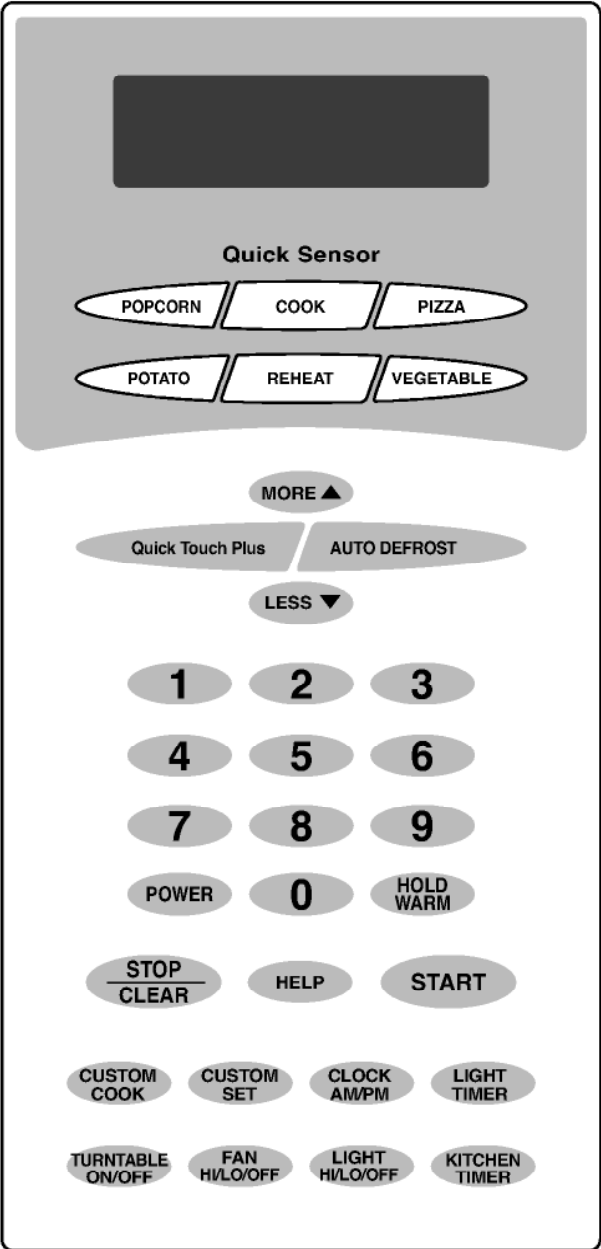

CONTROL PANEL INSTRUCTIONS

The entire operation is done by simple touch control pads.

- (1) **Display Window**
Numbers and letters are shown in the display window (Vacuum Fluorescent Tube).
Each Indicator Light shows which function is set and involved in the course of cooking by turning itself on. Indicator Lights automatically go out upon completion of cooking.
- (2) **MORE(+), LESS(-) Key**
Used to add or subtract ten seconds of cooking time each time pressing it.
- (3) **POWER Key**
Used to select cooking power level.
- (4) **Quick Touch Plus Key**
Used to cook for one minute at 100% power level. It can be used to extend cooking time in multiples of one minute up to 99 minutes.
- (5) **CLOCK(TIME OF DAY) Key**
Used in setting Time of Day.
- (6) **STOP/CLEAR Key**
Used to stop the oven or clear all entries except Time of Day.
- (7) **START Key**
Touch the START key after setting the desired cooking times etc. Also touch the START key to resume cooking after the cooking is temporarily stopped by opening the door. The key will not function unless the door is closed.
- (8) **DEFROST Key**
Used to defrost for frozen foods by weight.
- (9) **QUICK TOUCH (For Model 85910, 85919 only)**
Used to cook the preprogrammed food automatically.
- (10) **QUICK SENSOR (For Model 85970 only)**
Used to cook common microwave-prepared foods without needing to program times and cook powers.
- (11) **HELP Key**
This HELP key display feature information and helpful hints.
- (12) **LIGHT TIMER Key**
Used to set the cooktop light to turn on and off automatically at any time you want. The light comes on at the same time every day until reset.
- (13) **KITCHEN TIMER Key**
Used to set the timer.
- (14) **CUSTOM SET Key**
Touch this pad to change the oven's default setting for sound, clock, display speed, defrost weight, and demo mode operations.
- (15) **FAN HI/LO/OFF Key**
Touch FAN once for HIGH fan speed, twice for low fan speed, or threetimes to turn the fan off.
- (16) **LIGHT HI/LO/OFF Key**
Touch LIGHT once for bright light, twice for the night light, or three times to turn the light off.
- (17) **TURNTABLE ON/OFF Key**
Touch this pad to turn off the turntable. "T/TABLE OFF" will appear in the display.

OVERALL CIRCUIT DIAGRAM

SCHEMATIC DIAGRAM

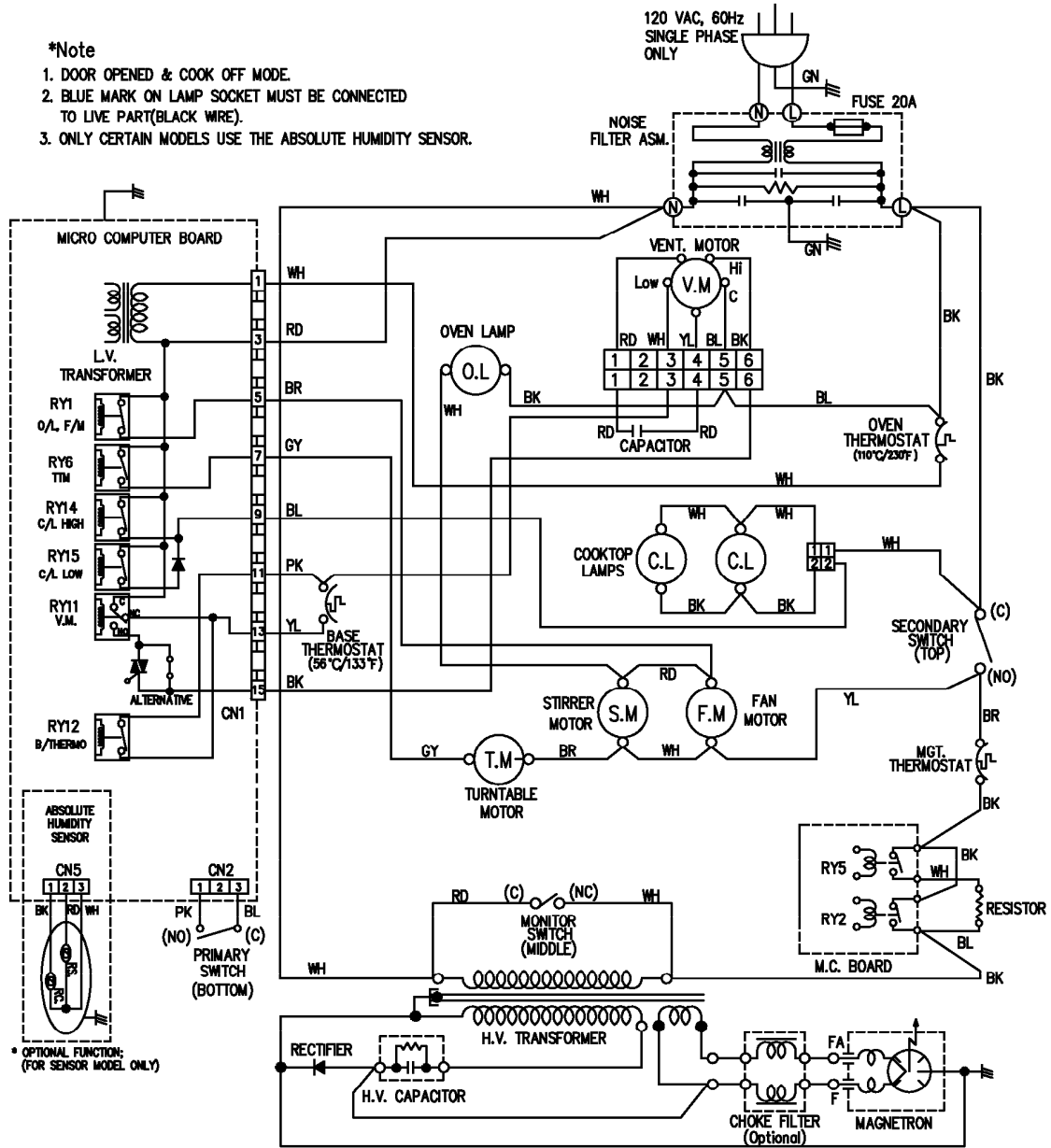

CONTROL MODULE

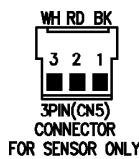
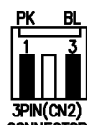
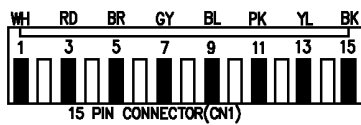

WIRE COLORS

SYMBOL	COLOR
WH	WHITE
BK	BLACK
RD	RED
YL	YELLOW
PK	PINK
BL	BLUE
BR	BROWN
GN	GREEN
GY	GREY

MATRIX CIRCUIT FOR TOUCH KEY BOARD

FOR MODEL 85910, 85919

	1	2	3	4	5	6	7
8	FAN HI/LO/OFF	HELP	COOK	POPCORN	N.C	5	0
9	LIGHT HI/LO/OFF	CUSTOM SET	REHEAT	POTATO	AUTO DEFROST	6	1
10	LESS	CLOCK AM/PM	QUICK TOUCH PLUS	BEVERAGE	KITCHEN TIMER	7	2
11	CUSTOM COOK	LIGHT TIMER	N.C	PIZZA	POWER	8	3
12	T/TABLE ON/OFF	STOP/ CLEAR	START	N.C	HOLD WARM	9	4
13	MORE	N.C	N.C	N.C	N.C	N.C	N.C

FOR MODEL 85970

	1	2	3	4	5	6	7
8	FAN HI/LO/OFF	HELP	N.C	N.C	N.C	5	0
9	LIGHT HI/LO/OFF	CUSTOM SET	N.C	N.C	AUTO DEFROST	6	1
10	LESS	CLOCK AM/PM	QUICK TOUCH PLUS	N.C	KITCHEN TIMER	7	2
11	CUSTOM COOK	LIGHT TIMER	N.C	N.C	POWER	8	3
12	T/TABLE ON/OFF	STOP/ CLEAR	START	N.C	HOLD WARM	9	4
13	MORE	SENSOR PIZZA	SENSOR POTATO	SENSOR POPCORN	SENSOR VEGETABLE	SENSOR REHEAT	SENSOR COOK

GENERAL INFORMATION FOR SERVICE

GENERAL PRECAUTIONS IN USE

A. Never operate the unit when it is empty.

Operating the oven with no load may shorten the life of the magnetron. Whenever cooking dry foods (dried fish, bread, etc.) or a small amount of food, be sure to put a glass of water into the cooking compartment. The glass turntable may become hot after operating, be careful when touching it.

B. Aluminum foil should be avoided because it will disrupt cooking and may cause arcing. However, small pieces may be used to cover some parts of food to slow the cooking. Any aluminum foil used should never be closer than 2.5 cm to any side wall of the oven.

- (1) Primary interlock switch
- (2) Secondary interlock switch
- (3) Interlock monitor switch
- (4) Choke system
- (5) Magnetron thermostat
- (6) Oven cavity thermostat

(Note: This thermostat located on the oven cavity will open and stop the unit from operation only if a high temperature is reached, such as, a fire created by overcooking food.)

B. Any one of 10 power output levels ranging 100W to 1000W can be selected by the touch control and electronic computer system.

TRIAL OPERATION

After installation, the following sequences and results should be checked carefully.

- A. Put a container filled with water (about 1 liter) into the oven, and close the door tightly.
- B. Set cooking time for 10 minutes by touching "1" and then "0" three times. "1, 0, 0, 0" appears in the display window.
- C. Touch the START key.
Make sure the cavity light comes on. The unit will begin cooking and the display window will show the time counting down by seconds.
- D. After about 5 minutes, make sure the primary interlock switch, the secondary interlock switch and the interlock monitor switch operate properly by opening and closing the door several times. Touch the START key each time the door is closed.
- E. Continue operating the unit. Two short and a long beep sound signal is heard when the time is up.
The unit will shut off automatically.
- F. Confirm the water is hot.
- G. Finally, measure the output power according to "POWER OUTPUT MEASUREMENT" on page 7-3.

FEATURES AND SPECIFICATIONS

FEATURES

- A. The safety systems incorporated in this model are:

SERVICE INFORMATION

PRECAUTIONS AND REPAIR SERVICE TIPS

PRELIMINARY

A. SINCE NEARLY 2,100 VOLTS EXISTS IN SOME CIRCUITS OF THIS UNIT REPAIRS SHOULD BE CARRIED OUT WITH GREAT CARE.

The filament leads of magnetron carry High Voltage with respect to ground. Extreme caution must be exercised. Never plug the unit into a power source to determine which component is defective in high voltage section.

B. TO AVOID POSSIBLE EXPOSURE TO MICROWAVE ENERGY LEAKAGE, THE FOLLOWING PRECAUTIONS MUST BE TAKEN BEFORE SERVICING.

- (1) Before the power is applied:
 - (a) Make sure the primary interlock switch, the secondary interlock switch and the interlock monitor switch operate properly by opening and closing the door several by opening and closing the door several times.
 - (b) Make sure the perforated screen and the dielectric choke of the door are correctly and firmly mounted.
- (2) After power is applied:
 - (a) Make sure the interlock switch mechanism is operating properly by opening and closing the door.
 - (b) Check microwave energy leakage must be below the limit of 5 mW/cm².
(All service adjustments should be made for minimum microwave energy leakage readings).

- (3) Do not operate the unit until it is completely repaired, if any of the following conditions exist. The unit must not be operated.

- (a) The door does not close firmly.
- (b) The hinge is broken.
- (c) The door seal is damaged.
- (d) The door is bent or warped, or there is any other visible damage on the unit that may cause microwave energy leakage.

NOTE: Always keep the seal clean.

- (e) Make sure that there are no defective parts in the interlock mechanism.
 - (f) Make sure that there are no defective parts in the microwave generating and transmission assembly (especially waveguide).
- (4) The following items should be checked after the unit is repaired:
 - (a) The interlock monitor switch is connected correctly and firmly.
 - (b) The magnetron gasket is properly positioned and mounted.
 - (c) The waveguide and the oven cavity are intact. (no microwave energy leakage)
 - (d) The door can be properly closed and the safety switches work properly.
 - (e) The unit must stop when the door is opened or the time is up.

The unit must not be operated with any of the above components removed or by-passed.

MICROWAVE LEAKAGE TEST

CAUTIONS

- Be sure to check microwave leakage prior to servicing the oven if the oven is operative prior to servicing.
- The service personnel should inform the manufacture importer, or assembler of any certified oven unit found to have a microwave emission level in excess of 5 mW/cm² and should repair any unit found to have excessive emission levels at no cost to the owner and should ascertain the cause of the excessive leakage. The service personnel should instruct the owner not to use the unit until the oven has been brought into compliance.
- If the oven operates with the door open, the service personnel should:
 - Tell the user not to operate the oven.
- The service personnel should check all surface and vent openings for microwave leakage.
- Check for microwave leakage after every servicing. The power density of the microwave radiation leakage emitted by the microwave oven should not exceed 4 mW/cm². Always start measuring of an unknown field to assure safety for operating personnel from radiation leakage.

EQUIPMENT

- TESTER (VOLTS-DC, AC, Ohmmeter)
- Microwave survey meter
 - Holaday HI-1500
HI-1501
 - Narda 8100
8200
- 600 cc non conductive material beaker (glass or plastic), inside diameter: approx. 8.5 cm (3¹/₂ in.)
- Glass thermometer: 100°C or 212°F (1 deg scale)

MEASURING MICROWAVE ENERGY LEAKAGE

- Pour 275±15cc of 20±5°C(68±9°F) water in a beaker which is graduated to 600 cc, and place the beaker on the center of the turntable.
- Set the energy leakage monitor to 2,450 MHz and use it following the manufacturer's recommended test procedure to assure correct result.
- When measuring the leakage, always use the 2-inch (5cm) spacer supplied with the probe.
- Operate the oven at its maximum output.
- Measure the microwave radiation using and electromagnetic radiation monitor by holding the probe perpendicular to the surface being measured.

Move probe along shaded area.

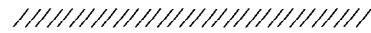

Probe scanning speed
Less than 2.5 cm/sec. (1 in/sec)

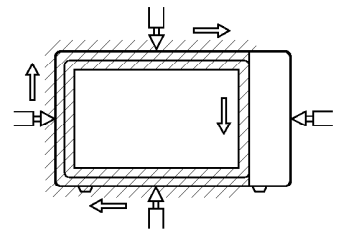

MEASUREMENT WITH THE OUTER CASE REMOVED

- (1) When you replace the magnetron, measure for microwave energy leakage before the outer case is installed and after all necessary components are replaced or adjusted. Special care should be taken in measuring the following parts.
 - Around the magnetron
 - The waveguide

WARNING: AVOID CONTACTING ANY HIGH VOLTAGE PARTS.

MEASUREMENT WITH A FULLY ASSEMBLED OVEN

- (1) After all components, including the outer panels, are fully assembled, measure for microwave energy leakage around the door viewing window, the exhaust opening and air inlet openings.
- (2) Microwave energy leakage must not exceed the values prescribed below.

NOTES:

Leakage with the outer panels removed - less than 5 mW/cm².

Leakage for a fully assembled oven ("Before the latch switch (primary) is interrupted") with the door in a slightly opened position - less than 2 mW/cm².

NOTE WHEN MEASURING

- (1) Do not exceed meter full scale deflection.
- (2) The test probe must be removed no faster than 1 inch/sec (2.5cm/sec) along the shaded area, otherwise a false reading may result.
- (3) The test probe must be held with the grip portion of the handle. A false reading may result if the operator's hand is between the handle and the probe.
- (4) When testing near a corner of the door, keep the probe perpendicular to the surface making sure the probe horizontally along the oven surface, this may possibly cause probe damage.

RECORD KEEPING AND NOTIFICATION AFTER MEASUREMENT

- (1) After adjustment and repair of any microwave energy interruption or microwave energy blocking device, record the measured values for future reference. Also enter the information on the service invoice.
- (2) Should the microwave energy leakage not be more than 2 mW/cm² after determining that all parts are in good condition, functioning properly and genuine replacement parts which are listed in this manual have been used.
- (3) At least once a year, have the electromagnetic energy leakage monitor checked for calibration by its manufacturer.

POWER OUTPUT MEASUREMENT

- (1) Microwave power output measurement is made with the microwave oven supplied at its rated voltage and operated at its maximum microwave power setting with a load of (1000±5) g of potable water.
- (2) The water is contained in a cylindrical borosilicate glass vessel having a maximum material thickness of 1/8" (3 mm) and an outside diameter of approximately 7.6" (190mm).
- (3) The oven and the empty vessel are at ambient temperature prior to the start of the test.
- (4) The initial temperature (T₁) of the water is (10±2)°C (50°F) It is measured immediately before the water is added to the vessel. After addition of the water to the vessel, the load is immediately placed on the center of the turntable which is in the lowest position and the microwave power switched on.
- (5) The time T for the temperature of the water to rise by a value ΔT of (10±2)°K is measured, where T is the time in seconds and ΔT is the temperature rise. The initial and final water temperatures are selected so that the maximum difference between the final water temperature and the ambient temperature is 5°K.

- (6) The microwave power output P in watts is calculated from the following formula :

$$P = \frac{4187 \times (\Delta T)}{T}$$

is measured while the microwave generator is operating at full power. Magnetron filament heat-up time is not included. (about 3 sec)

- (7) The water is stirred to equalize temperature throughout the vessel, prior to measuring the final water temperature.
- (8) Stirring devices and measuring instruments are selected in order to minimize addition or removal of heat.

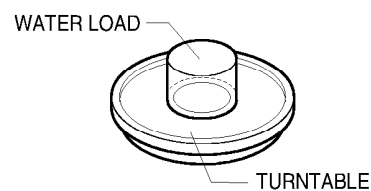

DISASSEMBLY INSTRUCTIONS

IMPORTANT NOTES:

UNIT MUST BE DISCONNECTED FROM ELECTRICAL OUTLET WHEN MAKING REPAIRS, REPLACEMENTS, ADJUSTMENTS AND CONTINUITY CHECKS. WAIT AT LEAST ONE MINUTE, UNTIL THE HIGH VOLTAGE CAPACITOR IN THE HIGH VOLTAGE POWER SUPPLY HAS FULLY DISCHARGED. THE CAPACITOR SHOULD BE DISCHARGED BY USING INSULATED WIRE - I.E. TEST PROBE CONNECTED TO 10K-OHM RESISTOR IN SERIES TO GROUND. WHEN RECONNECTING THE WIRE LEADS TO ANY PART, MAKE SURE THE WIRING CONNECTIONS AND LEAD COLORS ARE CORRECTLY MATCHED ACCORDING TO THE OVERALL CIRCUIT DIAGRAM. (ESPECIALLY SWITCHES AND HIGH VOLTAGE CIRCUIT.)

A. REMOVING POWER AND CONTROL CIRCUIT BOARD (Figures 1, 2 and 3)

- (1) Remove a screw securing the control panel assembly to the oven cavity.
- (2) Remove the control panel with pushing it upward.
- (3) Remove the three connectors (CN1, CN2) and wire leads (Relay2 and Relay5) from the circuit board.

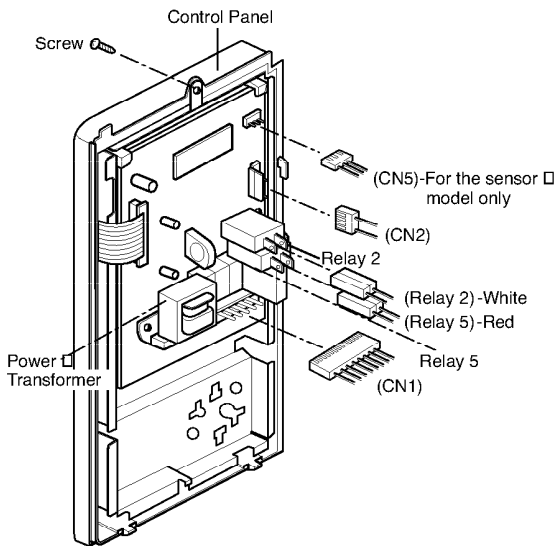

Figure 1

⚠ CAUTION: The relay connector 2(White) and 5(Red) must be correctly connected Relay 2 and Relay 5 for each. These two connectors are not interchangeable.

- (4) Remove 3 screws securing the circuit board.

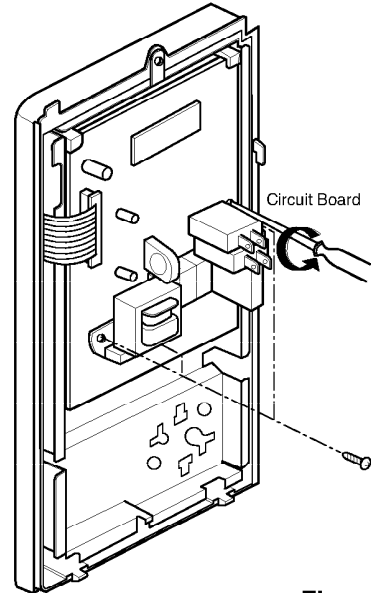

Figure 2

- (5) Remove the FPC connector from the terminal socket following "HOW TO REMOVE THE FPC CONNECTOR" on the next page.
- (6) Remove the circuit board from the control bracket carefully.

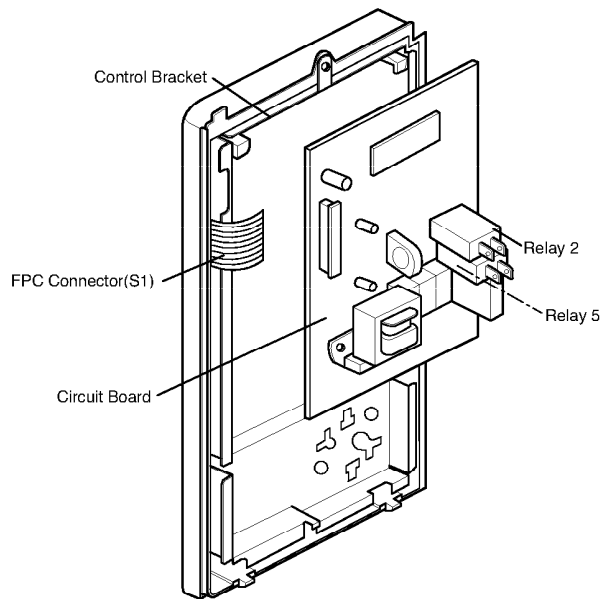

Figure 3

HOW TO REMOVE THE F.P.C. CONNECTOR

Follow the steps below as illustrated in Figures 4 and 5 to remove the F.P.C. connector.

- (1) Hold the edges of the plastic fastener with thumb and forefinger. (Figure 4)
- (2) Lift up the lever of the plastic fastener from the terminal socket by lightly pressing the lever end with forefinger. (Figure 5)
- (3) Remove the F.P.C. connector from the terminal socket.

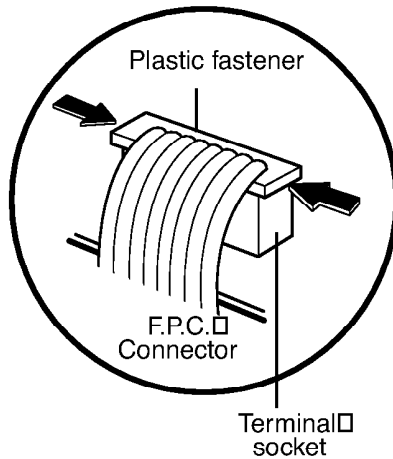

Figure 4

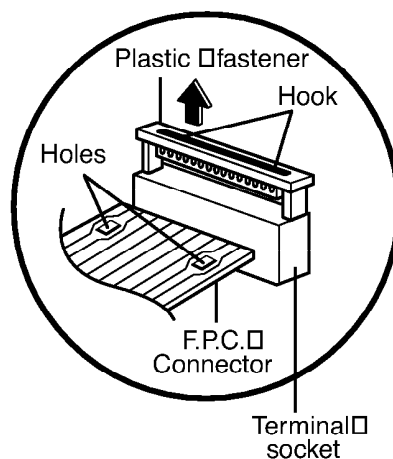

Figure 5

HOW TO INSERT THE F.P.C. CONNECTOR

Follow the steps below as illustrated in Figures 6 and 7 to insert the F.P.C. connector.

- (1) Insert the F.P.C. connector into the terminal socket securely with the fingers.
- (2) Hold the plastic fastener with thumb and forefinger of the other hand, and push it slowly into the terminal socket. (Figure 6)

NOTE: When reconnecting the F.P.C. connector make sure that the holes on the F.P.C. connector are properly engaged with the hooks on the plastic fastener

- (3) Lock the level of the plastic fastener into the hook of the terminal socket securely by releasing the fingers. (Figure 7)

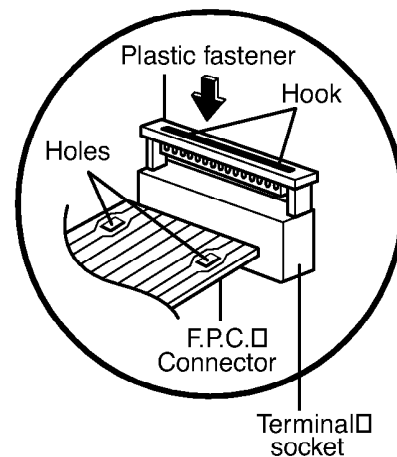

Figure 6

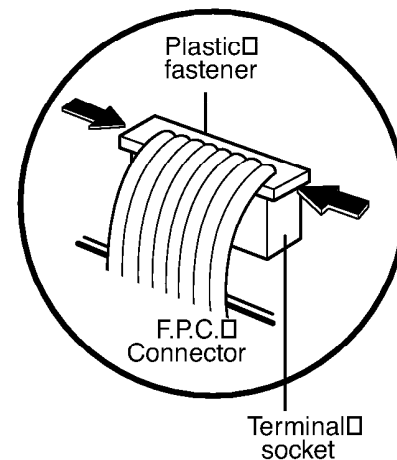

Figure 7

B. REMOVING THE OUT CASE(Figure 8)

- (1) Remove the vent grille by removing two screws securing it to the out case.
- (2) Remove two screws securing it to the front bracket.
- (3) Remove two screws securing it to the air duct.
- (4) Remove the mounting plate by turning the two screws securing it to the out case.
- (5) Remove the base plate by removing six screws securing it to the out case. Remove the Mount, All from the out case by removing two screws securing it to the out case and one screw securing it to the ventilation motor ASS'Y and cavity.
- (6) Remove the power cord cover from outcase by removing a screw.
- (7) Remove the power cord to the inner of the out case with turning power cord and remove the out case with pushing it back.

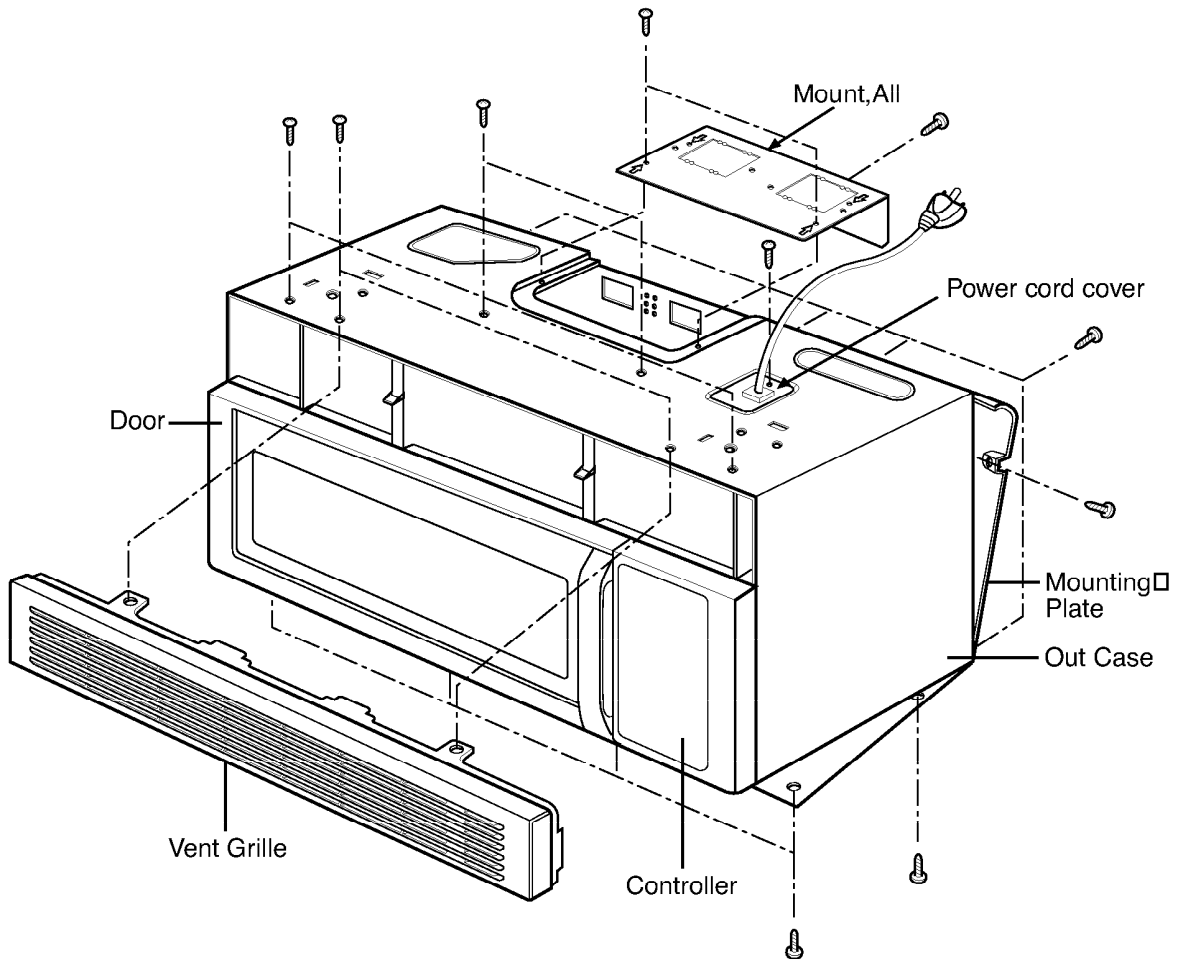

Figure 8

C REMOVING THE DOOR INTERLOCK SWITCHES (Figures 9,10)

- (1) Disconnect the wire leads from the interlock switches.
- (2) Remove two screws securing the Latch Board.
- (3) Make necessary replacements and check microwave energy leakage according to "ADJUSTMENT PROCEDURE" on page 7-12.

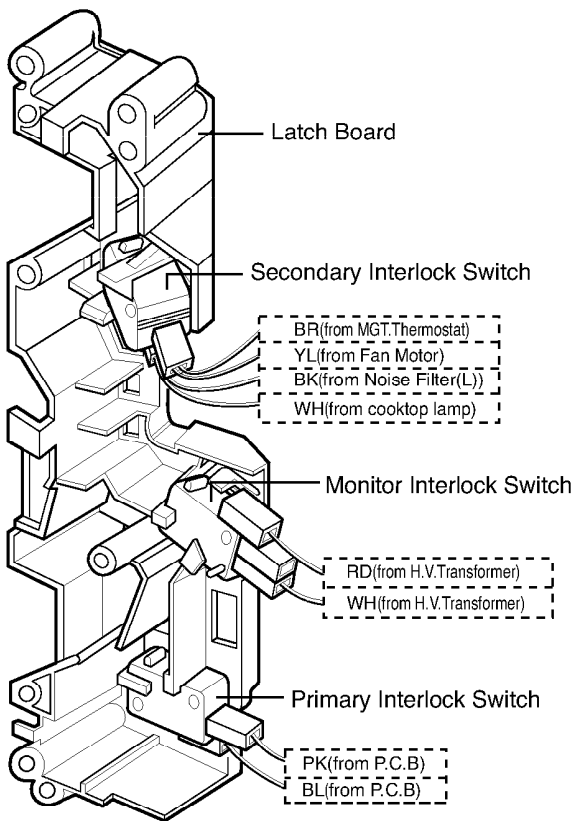

Figure 9

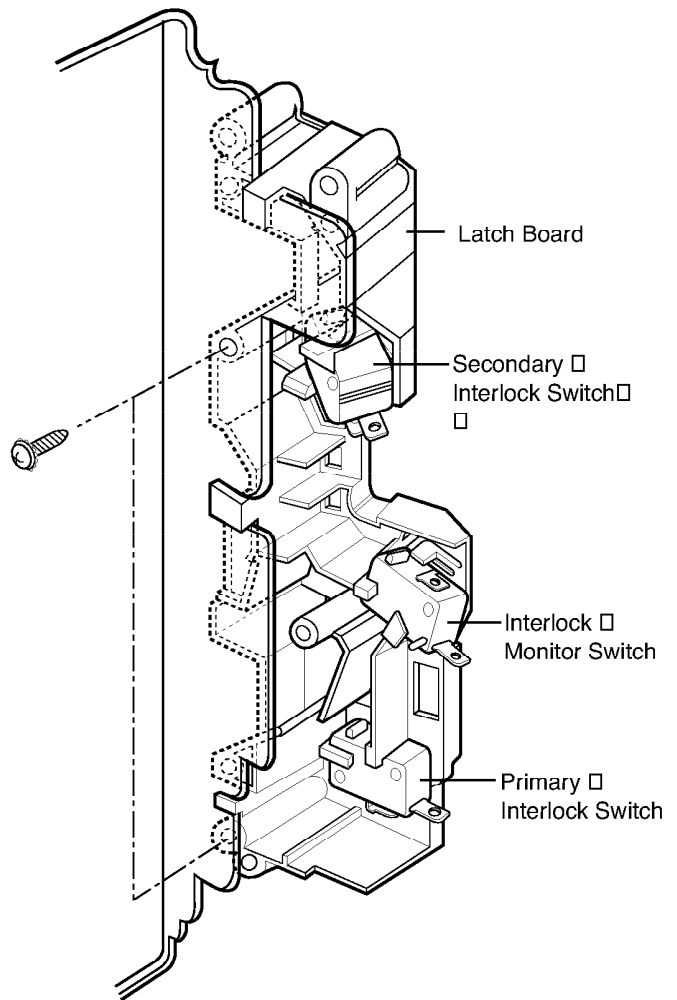

Figure 10

WIRE COLOR

SYMBOL	COLOR
WH □	WHITE □
BK □	BLACK □
BR □	BROWN □
RD □	RED □
BL □	BLUE □
PK □	PINK □
YL □	YELLOW □

□

D. REMOVING MAGNETRON

(Figures 11 Through 13)

- (1) Remove the vent grille by removing two screws. (Figure 11)
- (2) Remove the controller by removing a screw and disconnect all wire leads. (Figure 11)
- (3) Remove the base plate by removing six screws securing it to the oven front plate and outcase, remove the outcase by removing nine screws securing it to the oven back plate, air duct. (Figure 12)
- (4) Remove four tap tite screws securing the magnetron to the wave guide. (Figure 13)
- (5) Remove the magnetron VERY CAREFULLY.

NOTES:

- When removing the magnetron, make sure that its dome does not hit any adjacent parts, or it may be damaged.
- When replacing the magnetron, be sure to install the magnetron gasket in the correct position and be sure that the gasket is in good condition.
- After replacing the magnetron, check for microwave energy leakage with a survey meter. Check microwave energy leakage must be below the limit of 5 mW/cm². (All service adjustments should be made for minimum microwave energy leakage readings.)

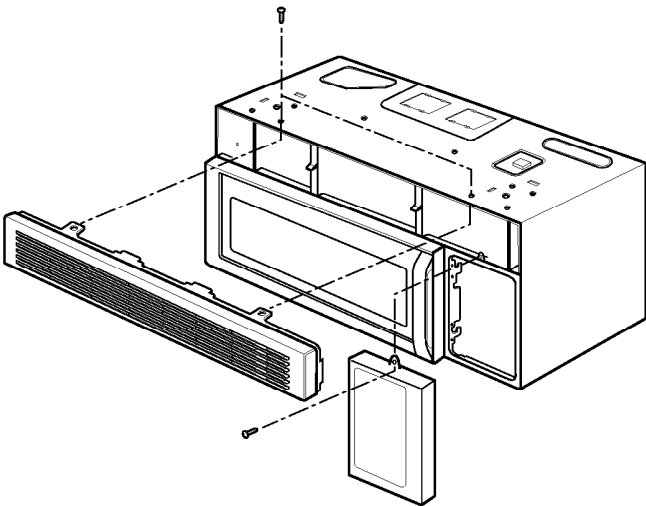

Figure 11

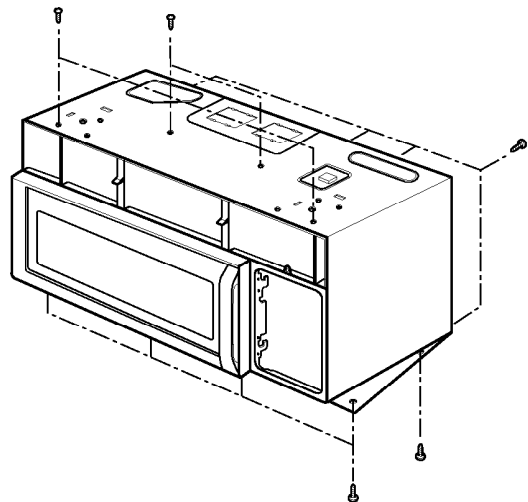

Figure 12

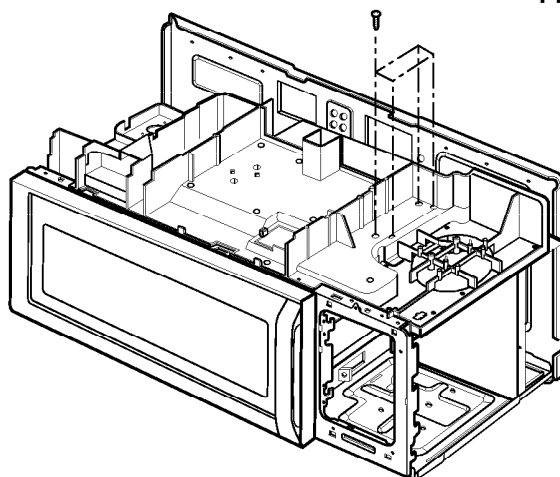

Figure 13

E. REMOVING STIRRER FAN DISK

(Figures 14 and 15)

- (1) Remove 1 rivet ASS'Y securing it to the oven upper plate by using knife blade.
- (2) Rotate slightly and pull out the stirrer fan cover.
- (3) Remove the stirrer fan disk.

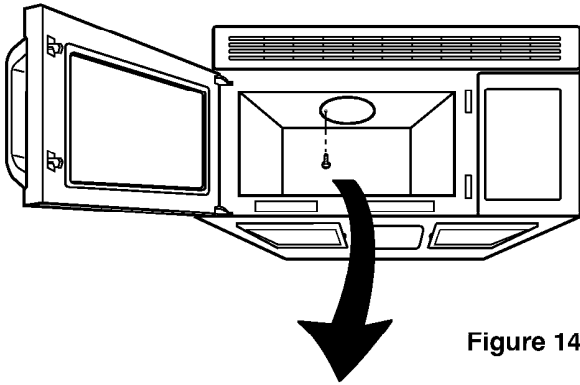

Figure 14

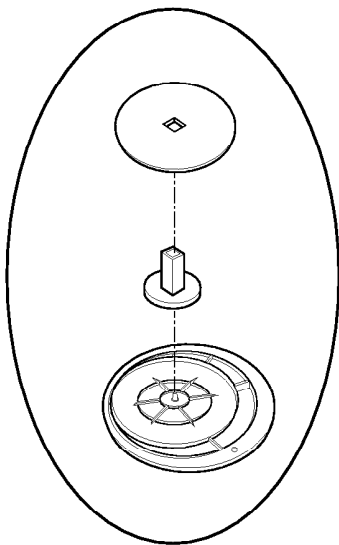

Figure 15

F. REMOVING DOOR (Figure 16)

- (1) Remove the vent grille by removing two screws securing it to the front bracket.
- (2) Lift up and push the door.

NOTES:

- After replacing the door, be sure to check that the primary interlock switch, the secondary interlock switch and the interlock monitor switch operate normally.
- After replacing the door, check for microwave energy leakage with a survey meter. Microwave energy leakage must be below the limit of $5\text{mW}/\text{cm}^2$. (With a 275 ml water load)

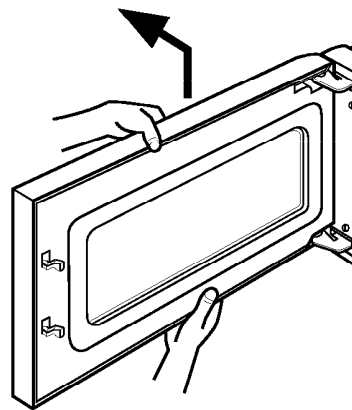

Figure 16

G. DISASSEMBLING DOOR (Figure 17)

- (1) Remove the dielectric choke by using knife blade or small screw driver, etc.
- (2) Remove two screws securing it to the door handle.

CAUTION: Be careful not to damage door seal plate with the screwdriver.

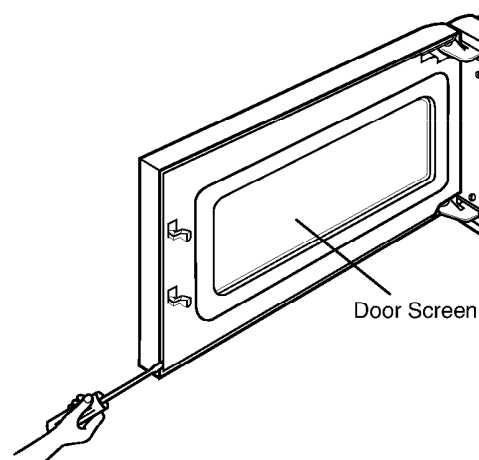
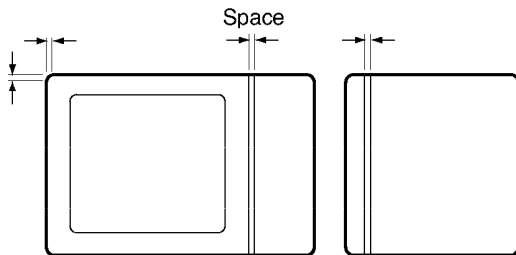

Figure 17

H. ASSEMBLING DOOR

- (1) When mounting the door assembly to the oven assembly, be sure to adjust the door assembly parallel to the chassis. Also adjust so the door has no play between the inner door surface and oven frame assembly. If the door assembly is not mounted properly, microwaves may leak from the clearance between the door and the oven.



I. REMOVING THE VENTILATION FAN ASS'Y

- (1) Remove the mounting plate by removing two screws securing it to the back plate. (See Figure 18)
- (2) Remove the two screws securing the MOUNT, ALL and one screw securing the ventilation fan ASS'Y. (See Figure 19)

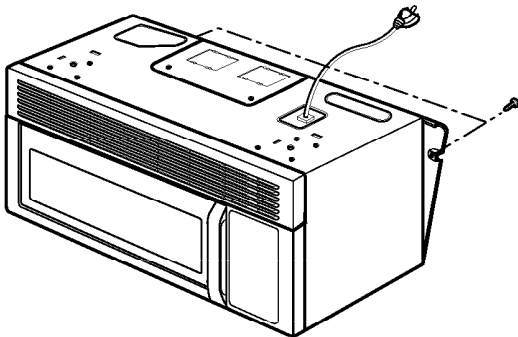

Figure 18

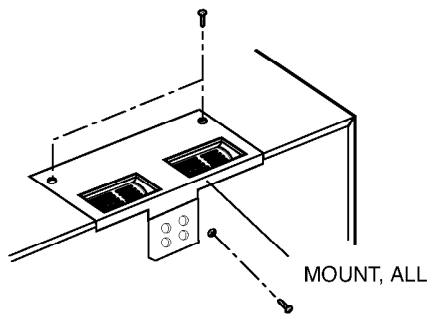

Figure 19

- (3) Carefully pull the ventilation motor ASS'Y out of the microwave oven. (See Figure 20-a)

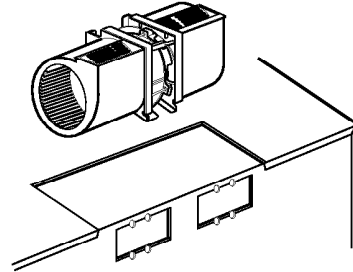

Figure 20-a

J. REPLACING THE HUMIDITY SENSOR

(For sensor model only)

- (1) Remove the sensor by removing two screws securing it to the air duct. (See Figure 20-b)
- (2) Mount the new humidity sensor to the air duct.

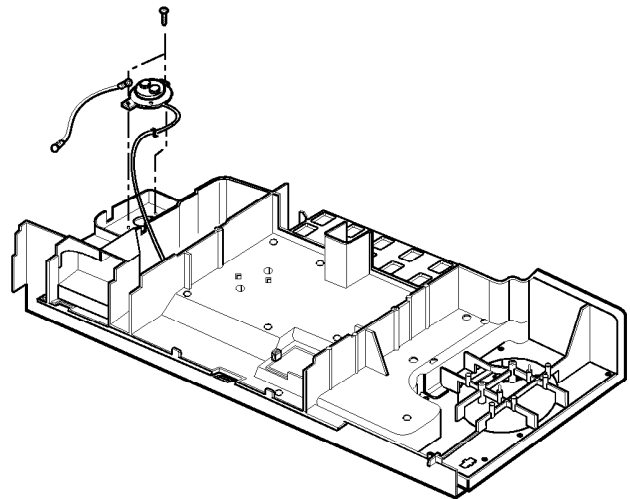

Figure 20-b

K. REMOVING THE TURNTABLE MOTOR

- (1) Remove the turntable.
- (2) Remove the turntable shaft VERY CAREFULLY with a slotted screwdriver. (Figure 21)
- (3) Remove the base plate by removing 6 screws securing it to the oven cavity. (Figure 22)
- (4) Disconnect the leadwire from the turntable motor terminals.
- (5) Remove the 2 screws securing the turntable motor to the oven cavity ASS'Y. (Figure 23)

NOTES:

- Remove the leadwire from the turntable motor VERY CAREFULLY.
- Be sure to grasp the connector not the wires when removing.

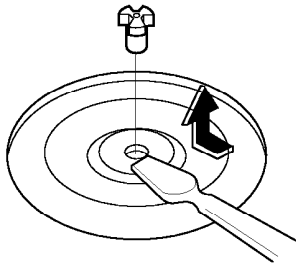

Figure 21

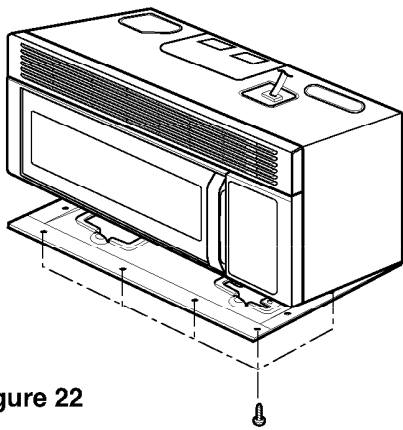

Figure 22

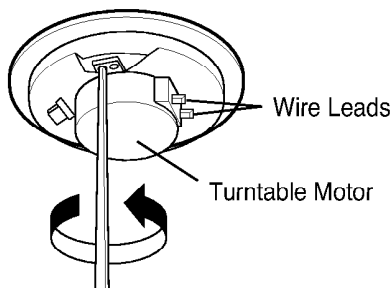

Figure 23

K. REMOVING THE STIRRER FAN MOTOR

- (1) Remove all screws from out case and remove the out case.
- (2) Remove 5 screws securing the air duct to the oven cavity, and remove 2 screws securing the stirrer fan motor to the bracket. (Figure 24)
- (3) Lift the air duct and disconnect the leadwire from the stirrer fan motor. (Figure 25)
- (4) Remove the stirrer fan motor.

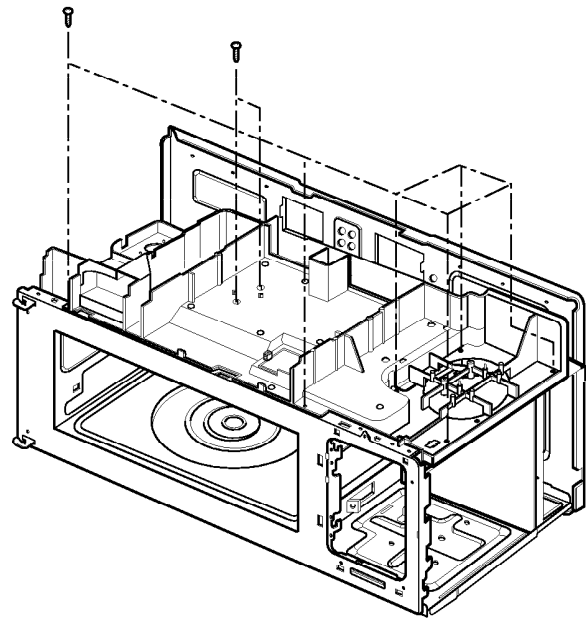

Figure 24

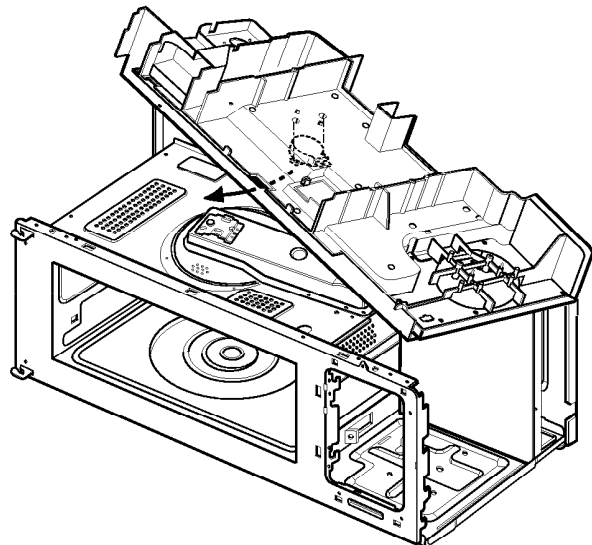

Figure 25

INTERLOCK SYSTEM

INTERLOCK MECHANISM

The door lock mechanism is a device which has been specially designed to eliminate completely microwave activity when the door is opened during cooking and thus to prevent the danger resulting from the microwave leakage.

ADJUSTMENT PROCEDURES

To avoid possible exposure to microwave energy leakage, adjust the door latches and interlock switches, using the following procedure.

The Interlock Monitor and Primary Interlock Switch act as the final safety switch protecting the user from microwave energy. The terminals between "COM" and "NC" of the Interlock Monitor must close when the door is opened. After adjusting the Interlock Monitor Switch, make sure that it is correctly connected.

Mounting of the primary/monitor/secondary switches to the latch board.

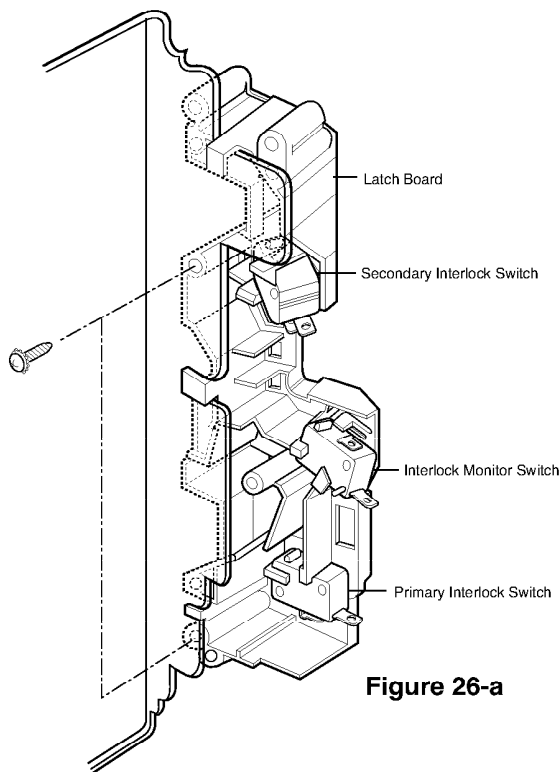

Figure 26-a

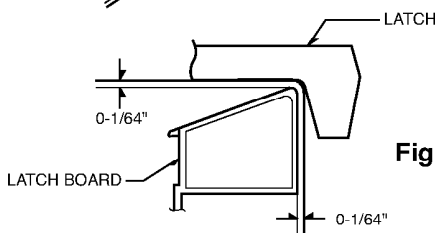

Figure 26-b

CHECK THE DOOR LATCH AND SWITCH CLOSING.

NOTE:

The outer cover of the microwave oven is removed.

- (1) Set the microwave oven on its side so that you can see the latch board and the switches, as shown in Figure 26-a.
- (2) Close the door tightly and check gaps A and B to be sure they are no more than 1/64" (0.5 mm). See Figure 26-b for close-up view of gaps A and B (door latches). If all gaps are less than 1/64" (0.5 mm), adjustment of the latch board may not be necessary. Go to Steps 5 and 6 to check the sequence of the switches.

NOTE:

To correct sequence of the Primary Interlock Switch, Secondary Interlock Switch and the Interlock Monitor Switch is very important.

If any gap is larger than 1/64" (0.5 mm), you will need to adjust the latch board". Go to step 3 and follow all steps in order.

ADJUST THE LATCH AND SWITCH CLOSING

- (3) Loosen the two screws holding the plastic latch board as shown.
- (4) With the oven door closed tightly, move the latch board upward toward the top of the oven and/or away from the door latch until the gaps are less than 1/64" (0.5 mm). Hold the latch board tightly in this position until you check the sequence of the switches in steps 5 and 6.

TEST THE LATCH AND SWITCH SEQUENCE

(5) Open the oven door slowly. Watch the door latch, the Secondary Switch. Release Rod and Lever on the switches to make sure they are zero to the body of the switches in the following sequence:

- Primary Interlock Switch
- Secondary Interlock Switch
- Interlock Monitor Switch

Adjust the latch board until the switches operate in this sequence. See Steps 3 and 4.

(6) Close the oven door slowly and be sure it is tightly closed. Watch the three switches to make sure they are zero to the body of the switches in the following sequence:

- Interlock Monitor Switch
- Primary Interlock Switch
- Secondary Interlock Switch

NOTE: The Interlock Monitor Switch is an added safety check on the Primary and Secondary Interlock Switches. If the Primary and Secondary Interlock Switches allow the oven to operate with the door open, the Monitor Switch will blow the fuse.

(7) When you achieve the proper sequence of switches in Steps 5 and 6, tighten the latch board screws at that point.

TEST THE MICROWAVE ENERGY LEAKAGE

Make sure the microwave energy leakage is below the limit of 1mW/cm² (with a 275 ml water load) and 5mW/cm² (with a 275 ml water load without the cabinet) when measured with a survey meter.

INTERLOCK CONTINUITY TEST

A. PRIMARY INTERLOCK SWITCH TEST

When the door is opened slowly, an audible **click** should be heard at the same time or successively at intervals and the latches should activate the switches with an audible **click**.

If the latches do not activate the switches when the door is closed, the switches should be adjusted in accordance with the adjustment procedure.

Disconnect the wire lead from the primary switch. Connect the ohmmeter leads to the common (COM) and normally open (NO) terminal of the switch. The meter should indicate an open circuit in the door open condition.

When the door is closed, the meter should indicate a closed circuit.

When the primary switch operation is abnormal, make the necessary adjustment or replace the switch only with the same type of switch.

B. SECONDARY INTERLOCK SWITCH TEST







Disconnect the wire lead from the secondary switch.

Connect the ohmmeter leads to the common (COM) and normally open (NO) terminals of the switch. The meter should indicate a open circuit in the door open condition. When the door is closed, meter should indicate an closed circuit. When the secondary switch operation is abnormal, make the necessary adjustment or replace the switch only with the same type of switch.

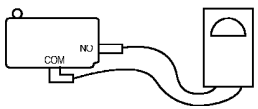
C. MONITOR SWITCH TEST

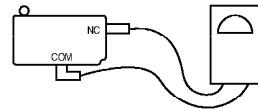
Disconnect the wire lead from the monitor switch. Connect the ohmmeter leads to the common (COM) and normally closed (NC) terminals of the switch. The meter should indicate closed circuit in the door open condition. When the door is closed, meter should indicate an open circuit. When the monitor switch operation is abnormal, replace with the same type of switch.

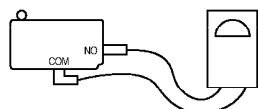
NOTE: After repairing the door or the interlock system, it is necessary to do this continuity test before operating the oven.

COMPONENTS	TEST PROCEDURE	RESULTS		
SWITCHES (Wire leads removed)	Check for continuity of the switch with an Ohm-meter	Door open	Door closed	
	Primary Switch			
	Monitor Switch			
	Secondary Switch			
NOTE : After checking for the continuity of switches, make sure that they are connected correctly.				

WARNING : FOR CONTINUED PROTECTION AGAINST EXCESSIVE RADIATION EMISSION, REPLACE ONLY WITH IDENTICAL REPLACEMENT PARTS.

TYPE NO. SZM-V16-FA-63 OR VP-533A-OF FOR PRIMARY SWITCH

TYPE NO. SZM-V16-FA-62 OR VP-532A-OF FOR MONITOR SWITCH

TYPE NO. SZM-V16-FA-63 OR VP-533A-OF FOR SECONDARY SWITCH

TEST AND CHECKOUT PROCEDURES, AND TROUBLE SHOOTING

- CAUTIONS -

- DISCONNECT THE POWER SUPPLY CORD FROM THE WALL OUTLET WHENEVER REMOVING THE CABINET FROM THE UNIT. PROCEED WITH THE TESTS ONLY AFTER DISCHARGING THE HIGH VOLTAGE CAPACITOR AND REMOVING THE WIRE LEADS FROM THE PRIMARY WINDING OF THE HIGH VOLTAGE TRANSFORMER. (SEE FIGURE 27)
- ALL OPERATIONAL CHECKS WITH MICROWAVE ENERGY MUST BE DONE WITH A LOAD (1 LITER OF WATER IN CONTAINER) IN THE OVEN.

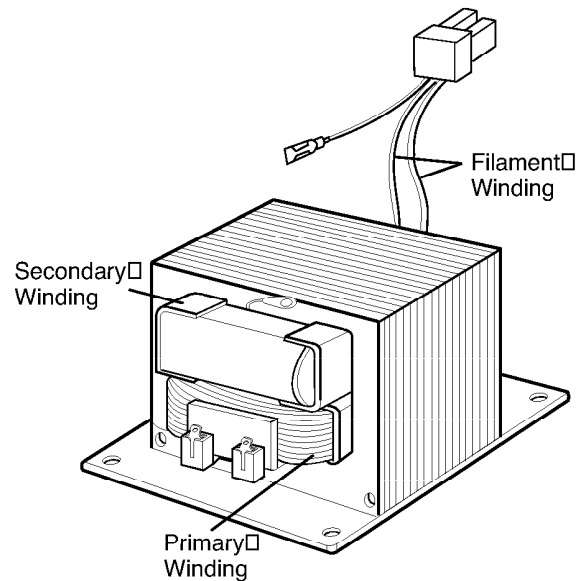
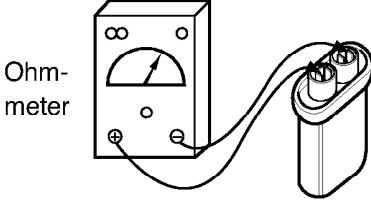
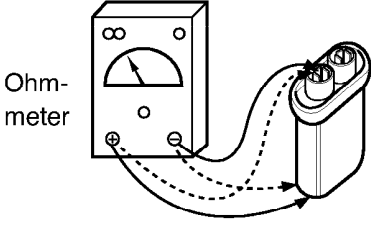
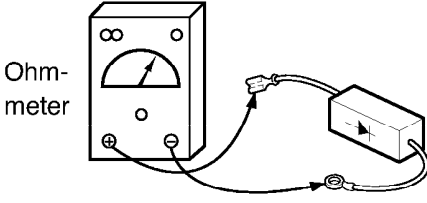
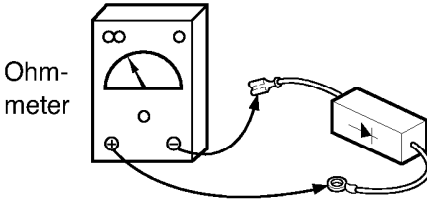

Figure 27

A. TEST PROCEDURES

COMPONENTS	TEST PROCEDURES	RESULTS
MAGNETRON (Wire leads are removed)	<ol style="list-style-type: none"> 1) Measure the resistance: Across the filament terminals of the magnetron with an ohm-meter on Rx1 scale. 2) Measure the resistance: Between each filament terminal of the magnetron and the chassis ground with an ohm-meter on high test scale. 	<p>Normal reading: Less than 1 ohm.</p> <p>Normal reading: Infinite ohms.</p> <p>NOTE: Replace the magnetron, if the magnetron checks and all of the high voltage component tests are good, but the unit still does not heat a load.</p>
HIGH-VOLTAGE TRANSFORMER (Wire leads are removed)	<ol style="list-style-type: none"> 1) Measure the resistance: With an ohm-meter on Rx1 scale. <ol style="list-style-type: none"> a. Primary winding; b. Filament winding; c. Secondary winding; 2) Measure the resistance: With an ohm-meter on highest scale. <ol style="list-style-type: none"> a. Primary winding to ground; b. Filament winding to ground; 	<p>Normal readings: Approx. 0.3 to 0.5 ohm. Less than 0.1 ohm. Approx. 65 to 120 ohms.</p> <p>Normal readings: Infinite ohms. Infinite ohms.</p>

NOTE: A MICROWAVE ENERGY LEAKAGE TEST MUST ALWAYS BE PERFORMED WHEN THE UNIT IS SERVICED FOR ANY REASON.

COMPONENTS	TEST PROCEDURES	RESULTS
HIGH-VOLTAGE CAPACITOR	Measure the resistance: (1) Terminal to terminal  Figure 28-a	Normal reading: Momentarily indicates several ohms, and then gradually returns to infinite ohms. Abnormal reading: Indicates continuity or infinite ohms from the beginning.
	(2) Terminal to case  Figure 28-b	Normal readings: Infinite. Abnormal reading: Indicates continuity.
HIGH-VOLTAGE DIODE	Measure the continuity: (1) Forward  Figure 29-a	Normal readings: continuity. Abnormal reading: Infinite.
	(1) Reverse  Figure 29-b	Normal readings: Infinite. Abnormal reading: continuity.

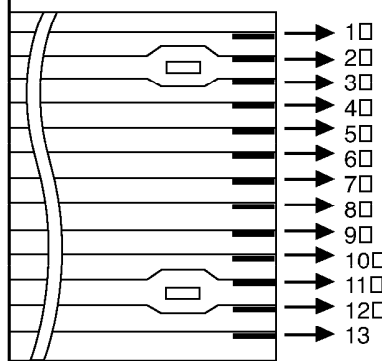
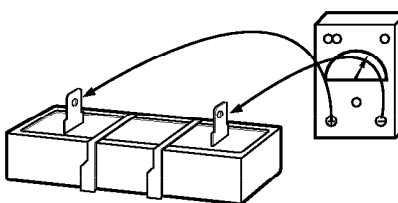
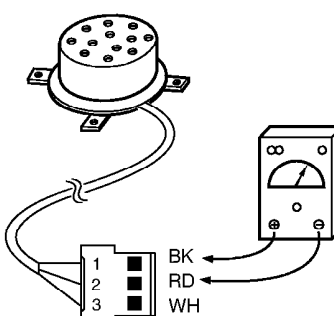
COMPONENTS	TEST PROCEDURES	RESULTS																																																														
<p style="text-align: center;">TOUCH KEY BOARD</p>	<p>Measure the resistance between terminal pins of connector KEY CONNECTOR.</p> <p>NOTE: When reconnecting the FPC connector, make sure that the holes on the FPC connector are properly engaged with hooks on the plastic fastener.</p> <p style="text-align: center;">MATRIX CIRCUIT FOR TOUCH KEY BOARD CONNECTOR(KEY CON)</p> <p>(For detail matrix circuit of each model, refer to page 5-2.)</p> <table border="1" style="margin-left: auto; margin-right: auto;"> <tr> <td></td> <td>1</td> <td>2</td> <td>3</td> <td>4</td> <td>5</td> <td>6</td> <td>7</td> </tr> <tr> <td>8</td> <td>FAN H/LQ/OFF</td> <td>HELP</td> <td>COOK</td> <td>POPCORN</td> <td>N.C</td> <td>5</td> <td>0</td> </tr> <tr> <td>9</td> <td>LIGHT H/LQ/OFF</td> <td>CUSTOM SET</td> <td>REHEAT</td> <td>POTATO</td> <td>AUTO DEFROST</td> <td>6</td> <td>1</td> </tr> <tr> <td>10</td> <td>LESS</td> <td>CLOCK AM/PM</td> <td>QUICK TOUCH PLUS</td> <td>BEVERAGE</td> <td>KITCHEN TIMER</td> <td>7</td> <td>2</td> </tr> <tr> <td>11</td> <td>CUSTOM COOK</td> <td>LIGHT TIMER</td> <td>N.C</td> <td>PIZZA</td> <td>POWER</td> <td>8</td> <td>3</td> </tr> <tr> <td>12</td> <td>T/TABLE ON/OFF</td> <td>STOP/CLEAR</td> <td>START</td> <td>N.C</td> <td>HOLD WARM</td> <td>9</td> <td>4</td> </tr> <tr> <td>13</td> <td>MORE</td> <td>N.C</td> <td>N.C</td> <td>N.C</td> <td>N.C</td> <td>N.C</td> <td>N.C</td> </tr> </table> <p style="text-align: center;">Figure 30</p>		1	2	3	4	5	6	7	8	FAN H/LQ/OFF	HELP	COOK	POPCORN	N.C	5	0	9	LIGHT H/LQ/OFF	CUSTOM SET	REHEAT	POTATO	AUTO DEFROST	6	1	10	LESS	CLOCK AM/PM	QUICK TOUCH PLUS	BEVERAGE	KITCHEN TIMER	7	2	11	CUSTOM COOK	LIGHT TIMER	N.C	PIZZA	POWER	8	3	12	T/TABLE ON/OFF	STOP/CLEAR	START	N.C	HOLD WARM	9	4	13	MORE	N.C	N.C	N.C	N.C	N.C	N.C	<table border="1" style="width: 100%; border-collapse: collapse;"> <tr> <th style="width: 30%;">Resistance value</th> <th style="width: 35%;">When touched</th> <th style="width: 35%;">When not touched</th> </tr> <tr> <td></td> <td style="text-align: center;">Less than 400 ohms</td> <td style="text-align: center;">More than 1 mega ohm</td> </tr> </table> <p style="text-align: center;">FPC CONNECTOR Top</p>  <p style="text-align: center;">Figure 31</p>	Resistance value	When touched	When not touched		Less than 400 ohms	More than 1 mega ohm
	1	2	3	4	5	6	7																																																									
8	FAN H/LQ/OFF	HELP	COOK	POPCORN	N.C	5	0																																																									
9	LIGHT H/LQ/OFF	CUSTOM SET	REHEAT	POTATO	AUTO DEFROST	6	1																																																									
10	LESS	CLOCK AM/PM	QUICK TOUCH PLUS	BEVERAGE	KITCHEN TIMER	7	2																																																									
11	CUSTOM COOK	LIGHT TIMER	N.C	PIZZA	POWER	8	3																																																									
12	T/TABLE ON/OFF	STOP/CLEAR	START	N.C	HOLD WARM	9	4																																																									
13	MORE	N.C	N.C	N.C	N.C	N.C	N.C																																																									
Resistance value	When touched	When not touched																																																														
	Less than 400 ohms	More than 1 mega ohm																																																														
<p style="text-align: center;">RESISTOR CEMENT</p>	<p>Measure the resistance</p>  <p style="text-align: center;">Figure 32</p>	<p>Normal reading: Approx. 15 ohm</p> <p>Abnormal reading: Infinite</p>																																																														
<p style="text-align: center;">SENSOR (For sensor model only)</p>	 <p style="text-align: center;">Figure 33</p>	<p>Normal: Approximately BK - RD: 4.5 ~ 6.2 Kohm RD - WH: 2.0 ~ 3.5 Kohm BK - WH: 2.0 ~ 3.5 Kohm</p> <p>Abnormal: Infinite or several.</p>																																																														

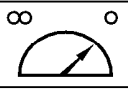
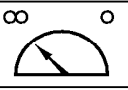
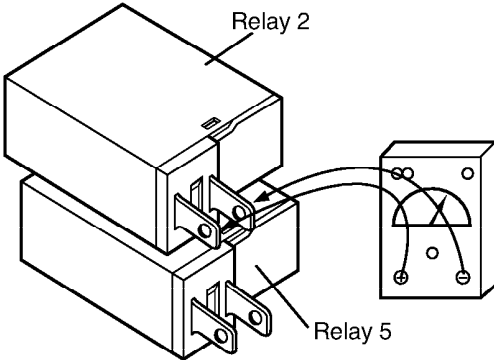
COMPONENTS	TEST PROCEDURES	RESULTS		
		POWER LEVEL		
RELAY2	<p>Check for continuity of relay 2 with an ohm-meter. (Remove wire leads from relay 2 and operate the unit.)</p>  <p>Figure 34 ⚠ CAUTION: The relay connector 2(White) and 5(Red) must be correctly connected Relay 2 and Relay 5 for each. These two connectors are not interchangeable.</p>	1	4 sec	18 sec
		2	6 sec	16 sec
		3	8 sec	14 sec
		4	10 sec	12 sec
		5	12 sec	10 sec
		6	14 sec	8 sec
		7	16 sec	6 sec
		8	18 sec	4 sec
		9	20 sec	2 sec
		10	22 sec	0

NOTES:

- A MICROWAVE ENERGY TEST MUST ALWAYS BE PERFORMED WHEN THE UNIT IS SERVICED FOR ANY REASON.
- MAKE SURE THE WIRE LEADS ARE IN THE CORRECT POSITION.
- WHEN REMOVING THE WIRE LEADS FROM THE PARTS, BE SURE TO GRASP THE CONNECTOR, NOT THE WIRES.

B. CHECKOUT PROCEDURES

(1) CHECKOUT PROCEDURES FOR FUSE BLOWING

CAUTION: REPLACE BLOWN FUSE WITH 20 AMPERE FUSE.

PROBLEMS	CAUSES
Fuse blows immediately after the door is closed.	Improper operation of the primary interlock, secondary interlock switches and/or the interlock monitor switch.
Fuse blows immediately after the door is opened.	
Fuse blows when the door is closed and START key is touched.	Malfunction of the high voltage transformer; the high voltage capacitor including the diode, the magnetron, the blower motor or the circuit board.

NOTES:

- If the fuse is blown by an improper switch operation, replace all switches and the fuse at the same time. After replacing the defective switches with new ones, make sure that they are correctly connected.
- Check for microwave energy leakage according to INTERLOCK ADJUSTMENT PROCEDURES on page 7-12 when the primary interlock, secondary interlock switches and/or the interlock monitor switches are adjusted or replaced.

(2) CHECKOUT PROCEDURES FOR RELAY.

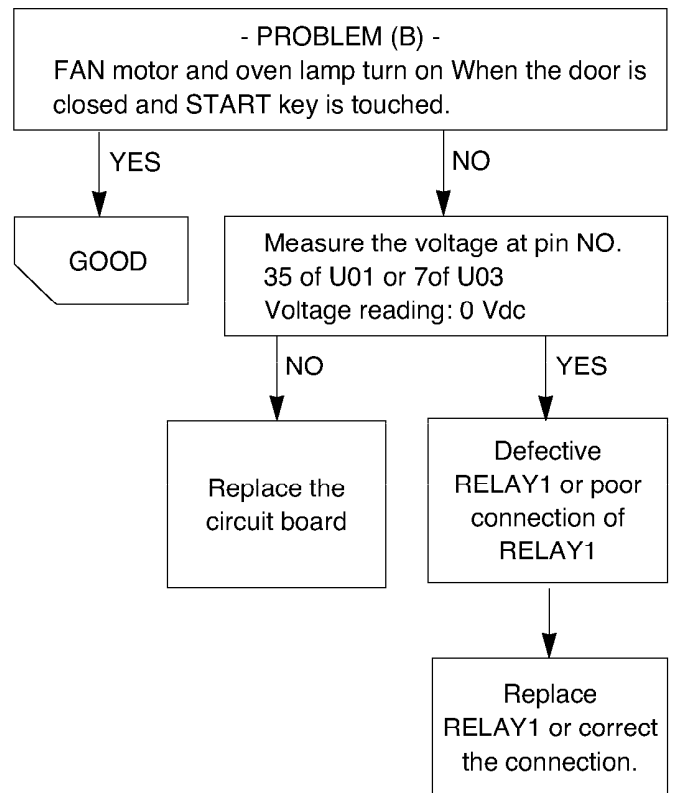
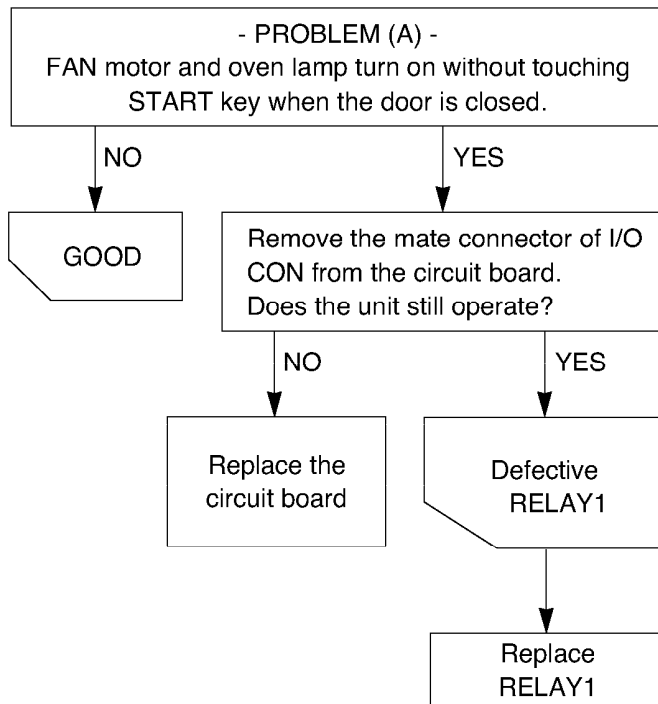

(3) CHECKOUT PROCEDURES FOR CIRCUIT BOARD

The following symptoms indicate a defective circuit board.

- 1) The start function fails to operate but the high voltage Systems, the interlock switches, the door sensing and the relay check good.
- 2) The unit with a normal relay continuously operates.
- 3) Proper temperature measurement is not obtained.
- 4) The buzzer does not sound or continues to sound.
- 5) Some segments of one or more digits do not light up, or they continue to light up, or segments light when they should not.
- 6) Wrong figures appear.
- 7) The figures of all digits.
- 8) Some of the indicators do no flicker light up.
- 9) The clock does not keep time properly.

NOTE: A MICROWAVE ENERGY LEAKAGE TEST MUST ALWAYS BE PERFORMED WHEN THE UNIT IS SERVICED FOR ANY REASON.

C. TROUBLE SHOOTING

Before following this troubleshooting read "TRIAL OPERATION" on page 6-1.
 f1) "DISPLAY" Problems, "A" thru "C"
 f1) "HELP UP" Problems, "D" thru "E"

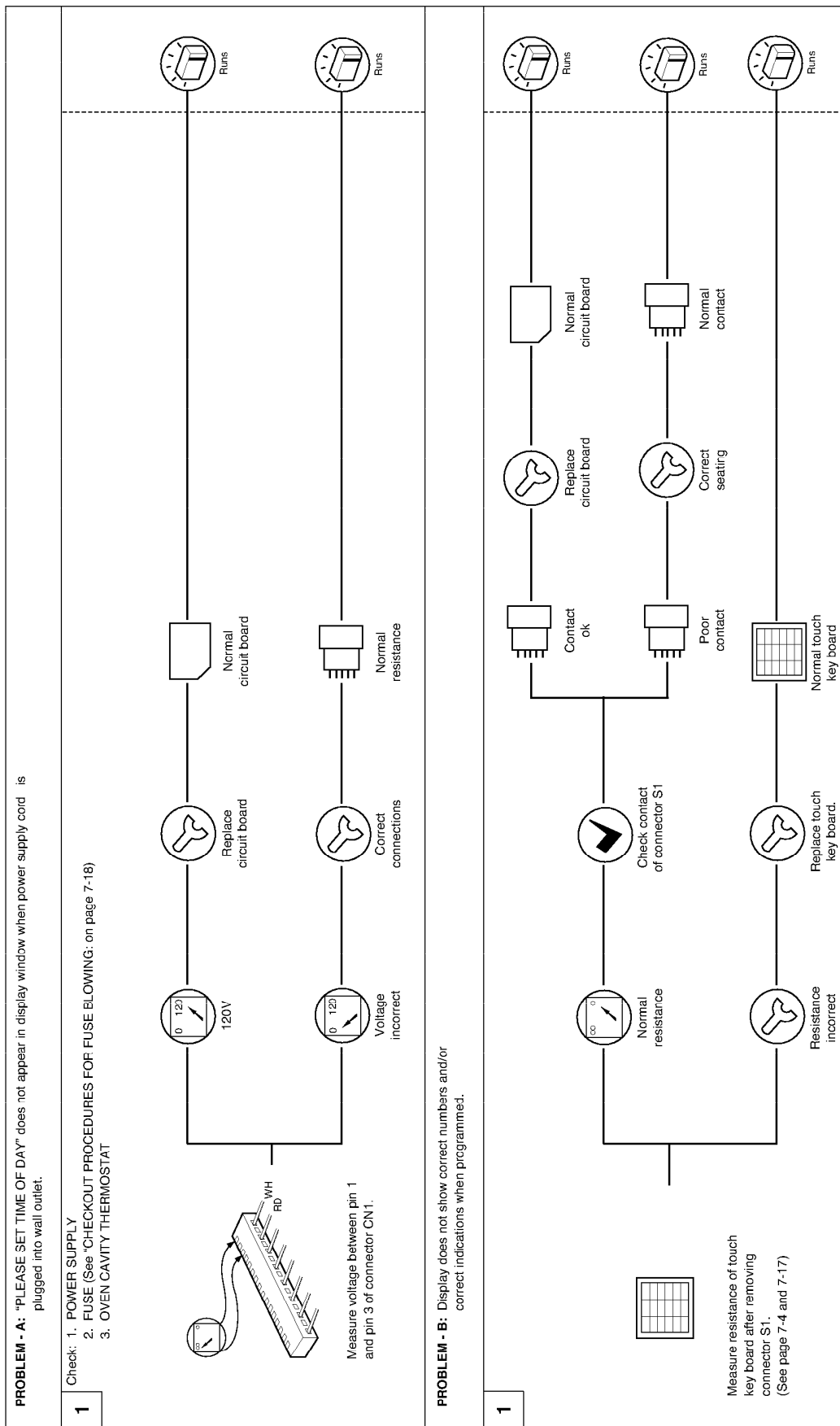

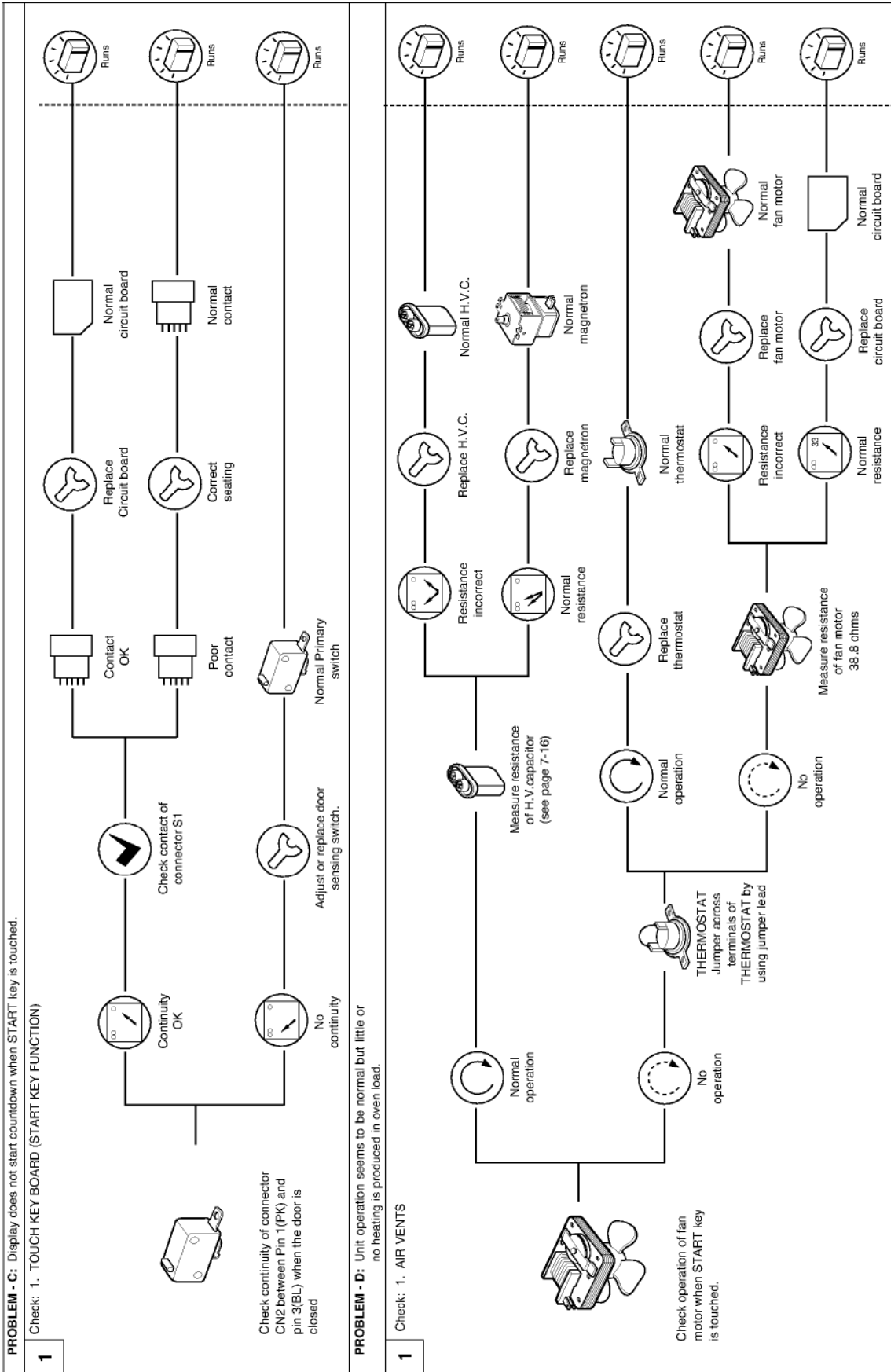

PROBLEM - E: Unit does not heat up even if display counts down when START key is touched for "HIGH POWER" cooking.

- 1 Check: 1. PRIMARY AND SECONDARY INTERLOCK SWITCHES
2. THERMOSTAT

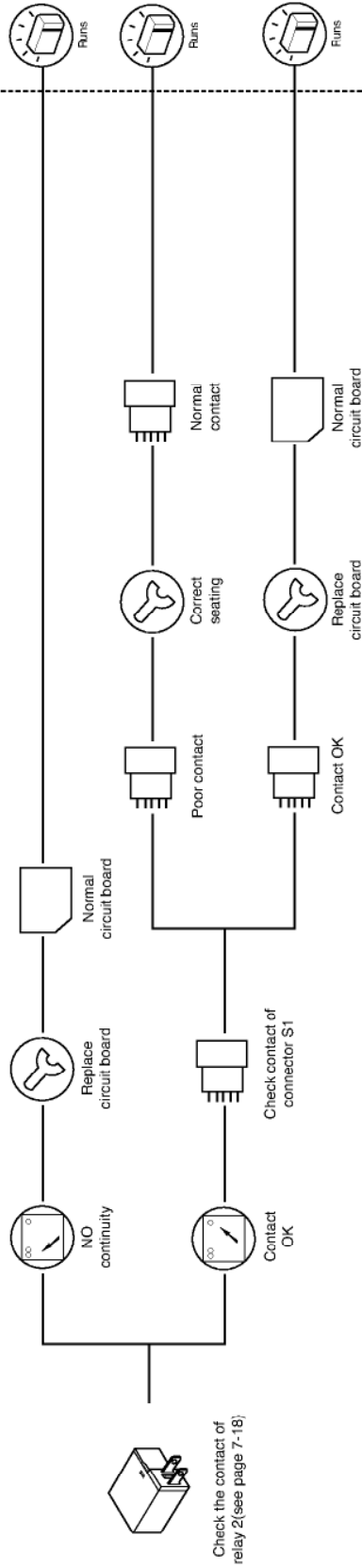

2

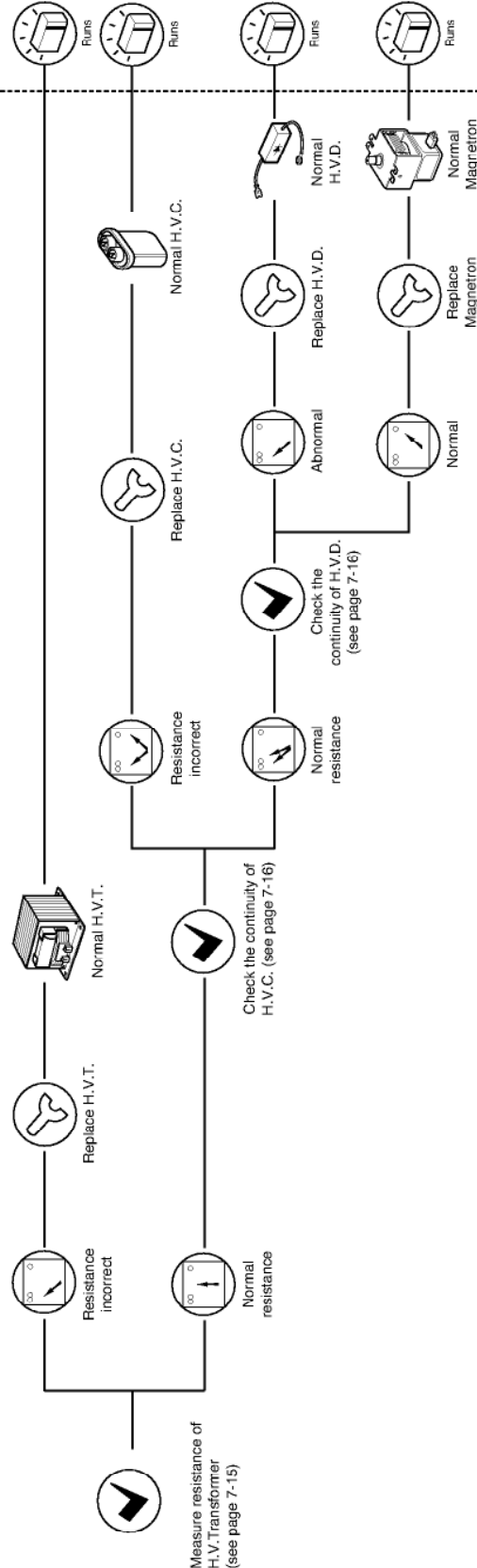

PROBLEM - F: No buzzing when touching the key, between stages or at end of cooking

1



Check normal operation circuit board



Replace circuit board



Normal circuit board



Runs

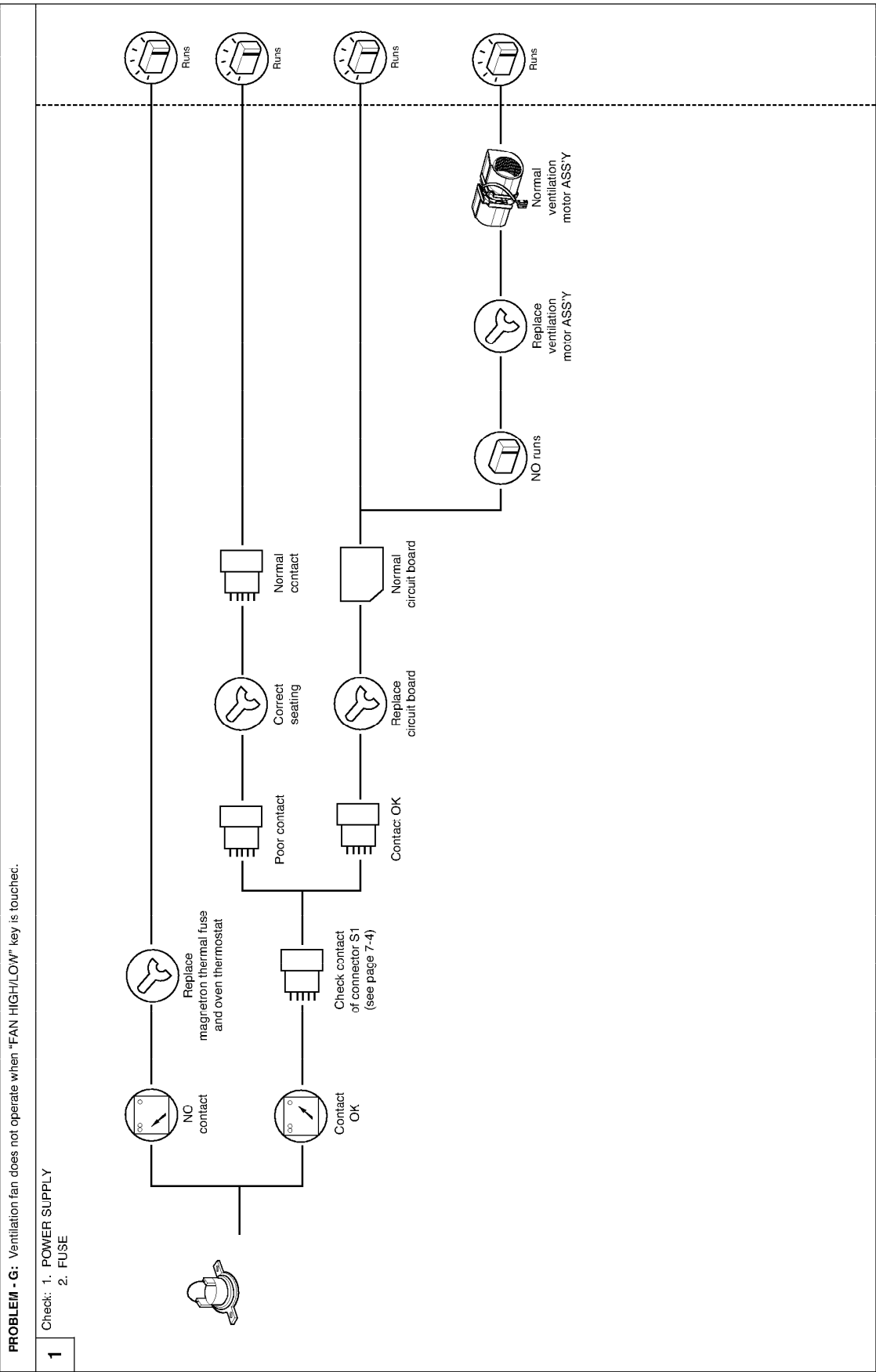

EXPLODED VIEW

DOOR PARTS

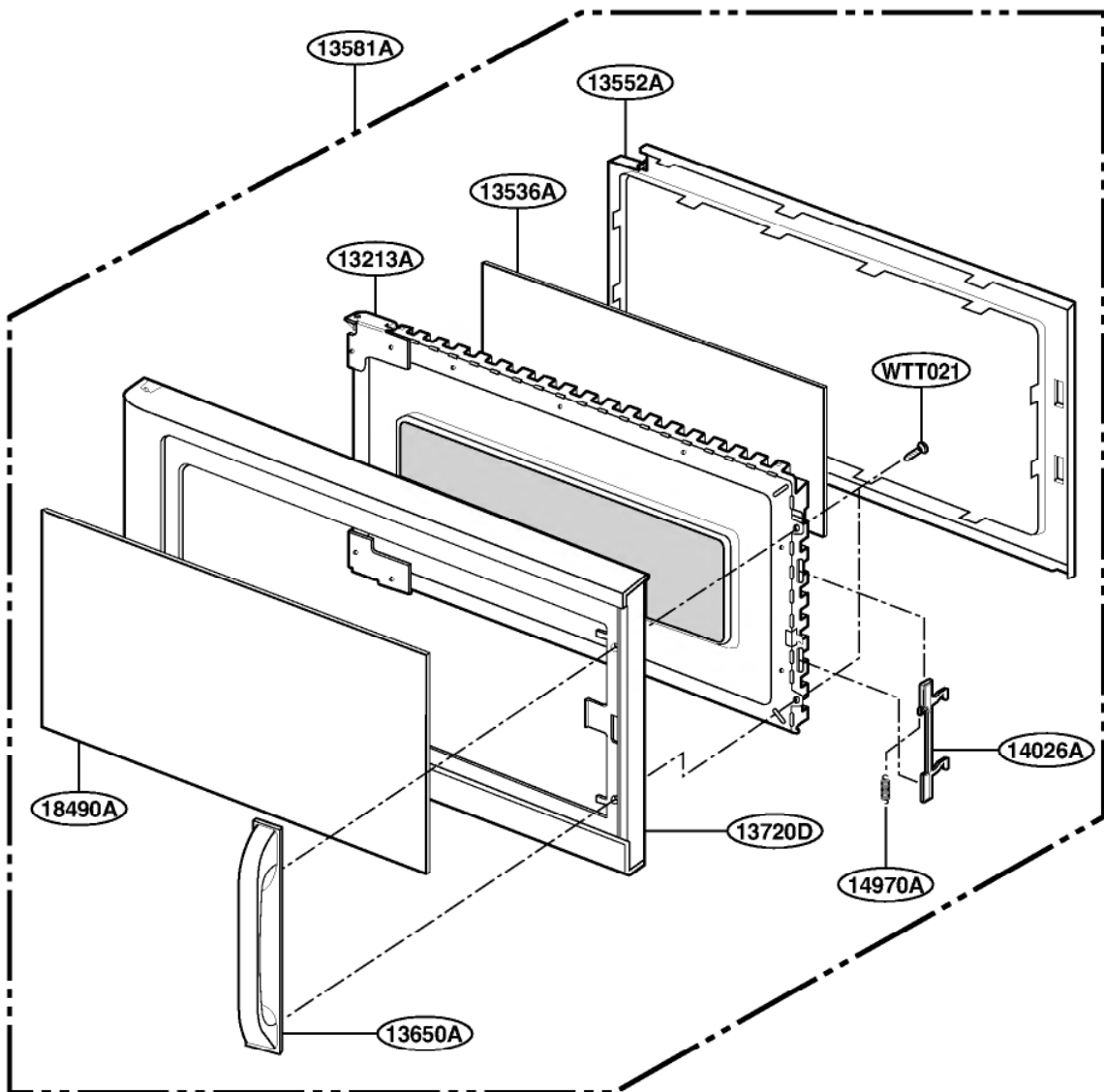

CONTROLLER PARTS

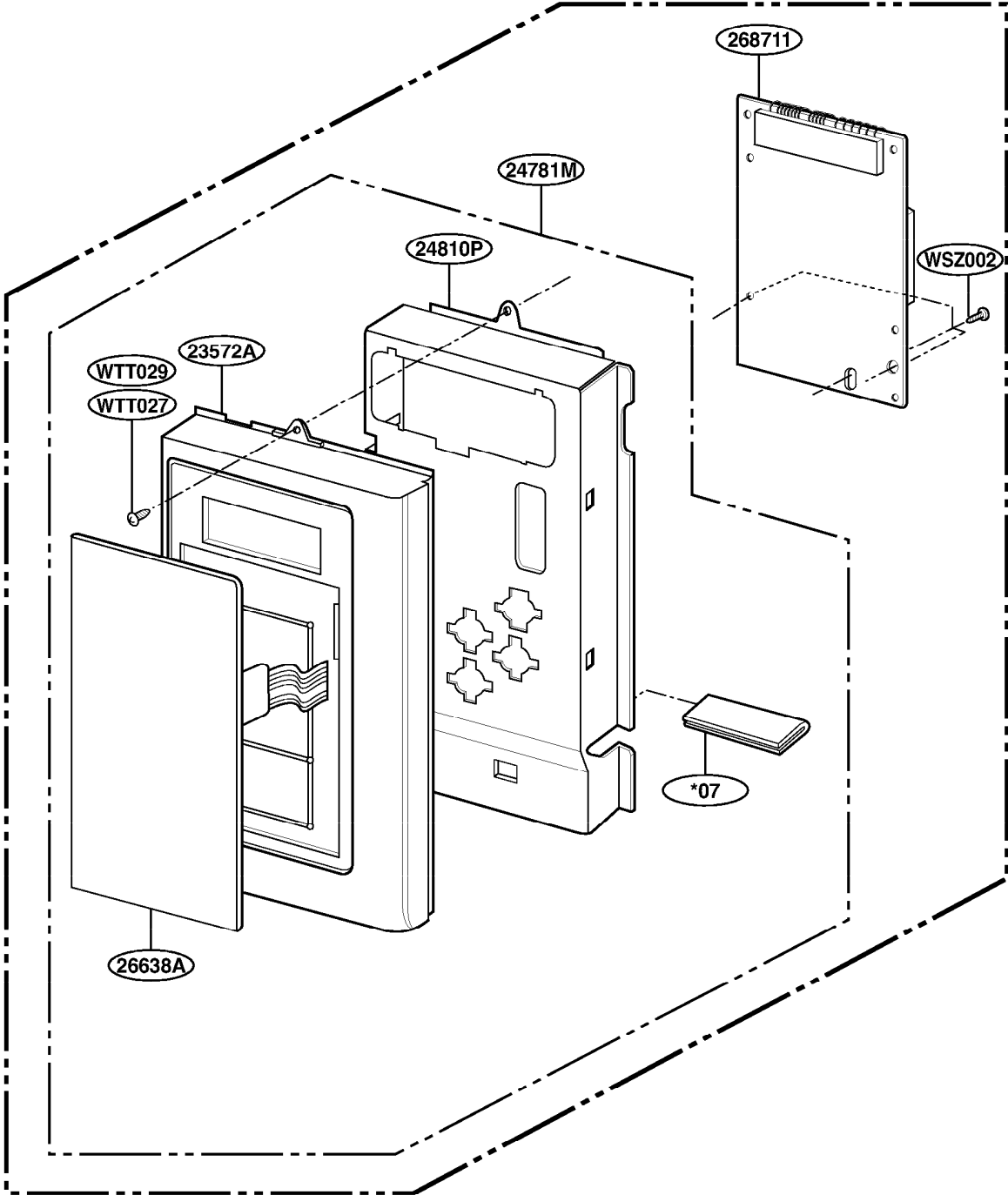

OVEN CAVITY PARTS

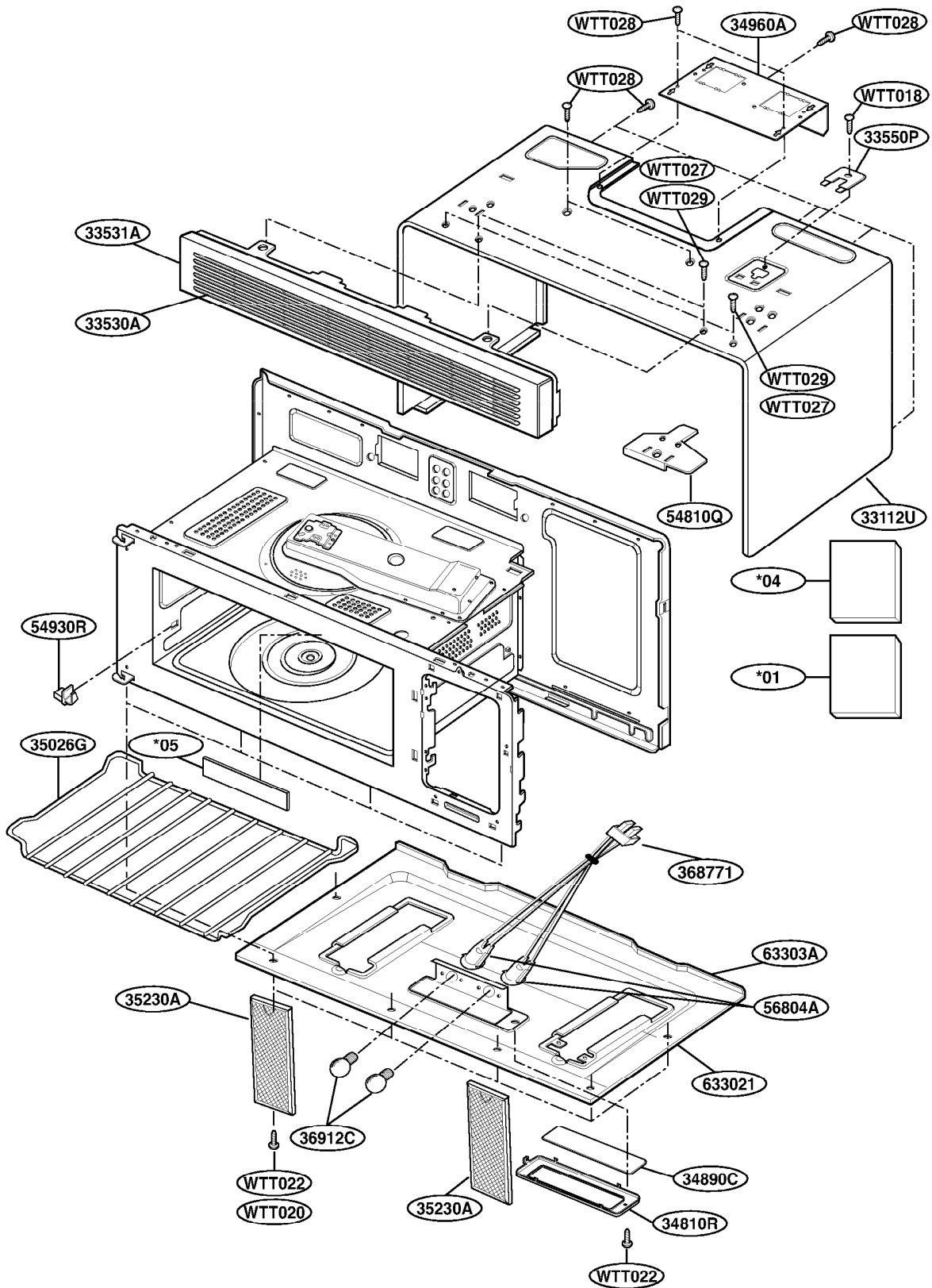

LATCH BOARD PARTS

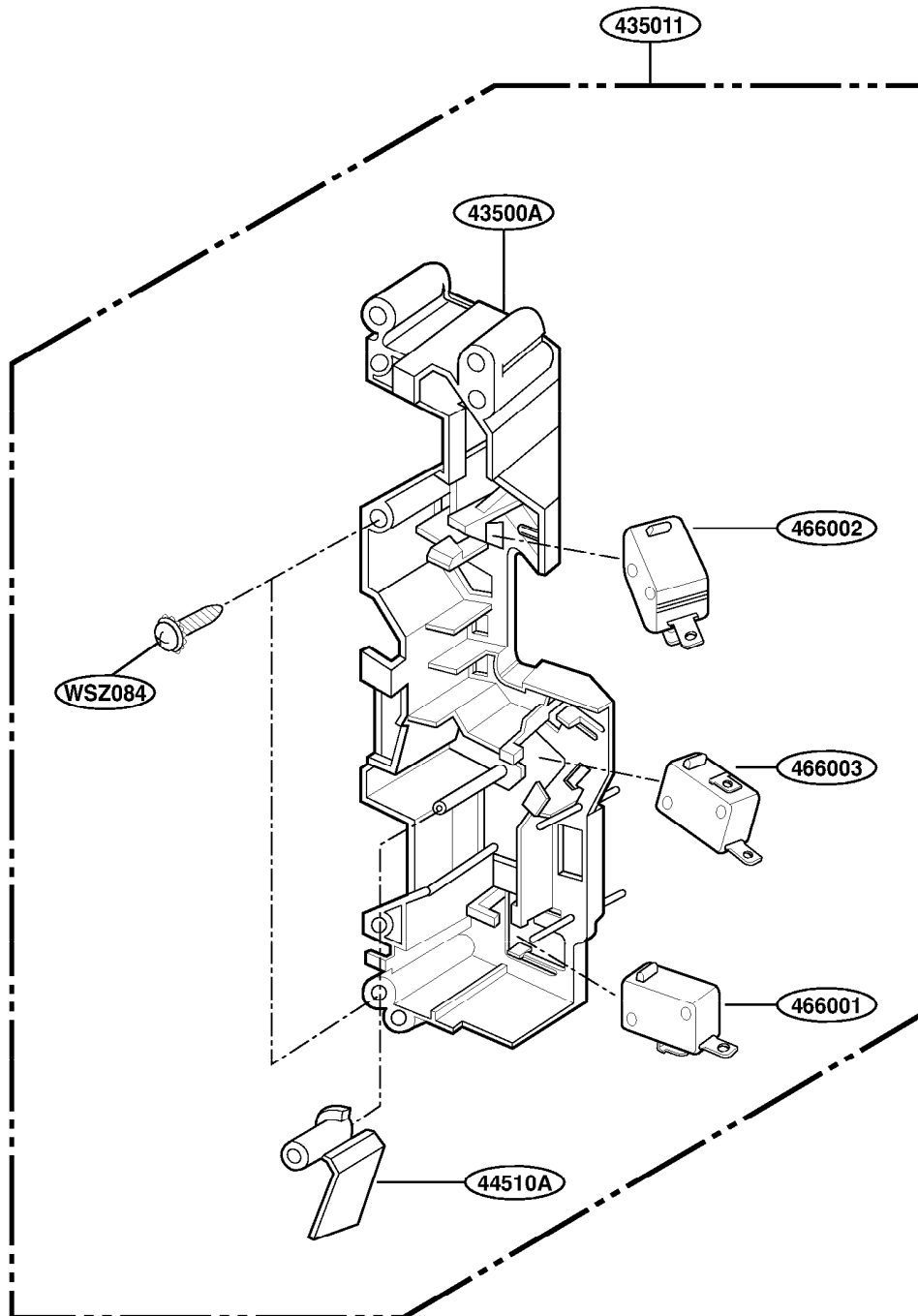

INTERIOR PARTS (I)

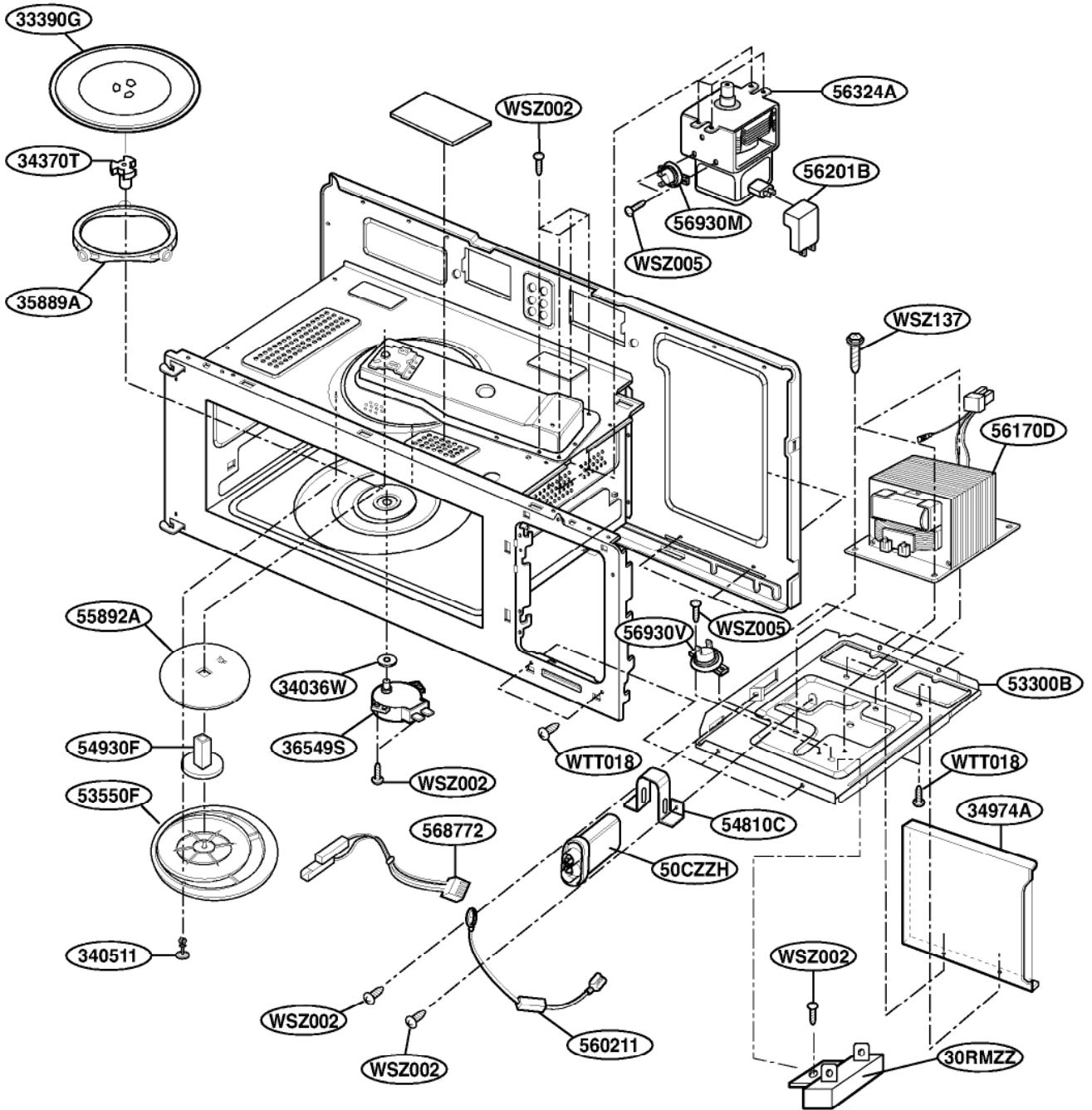

INTERIOR PARTS (II)

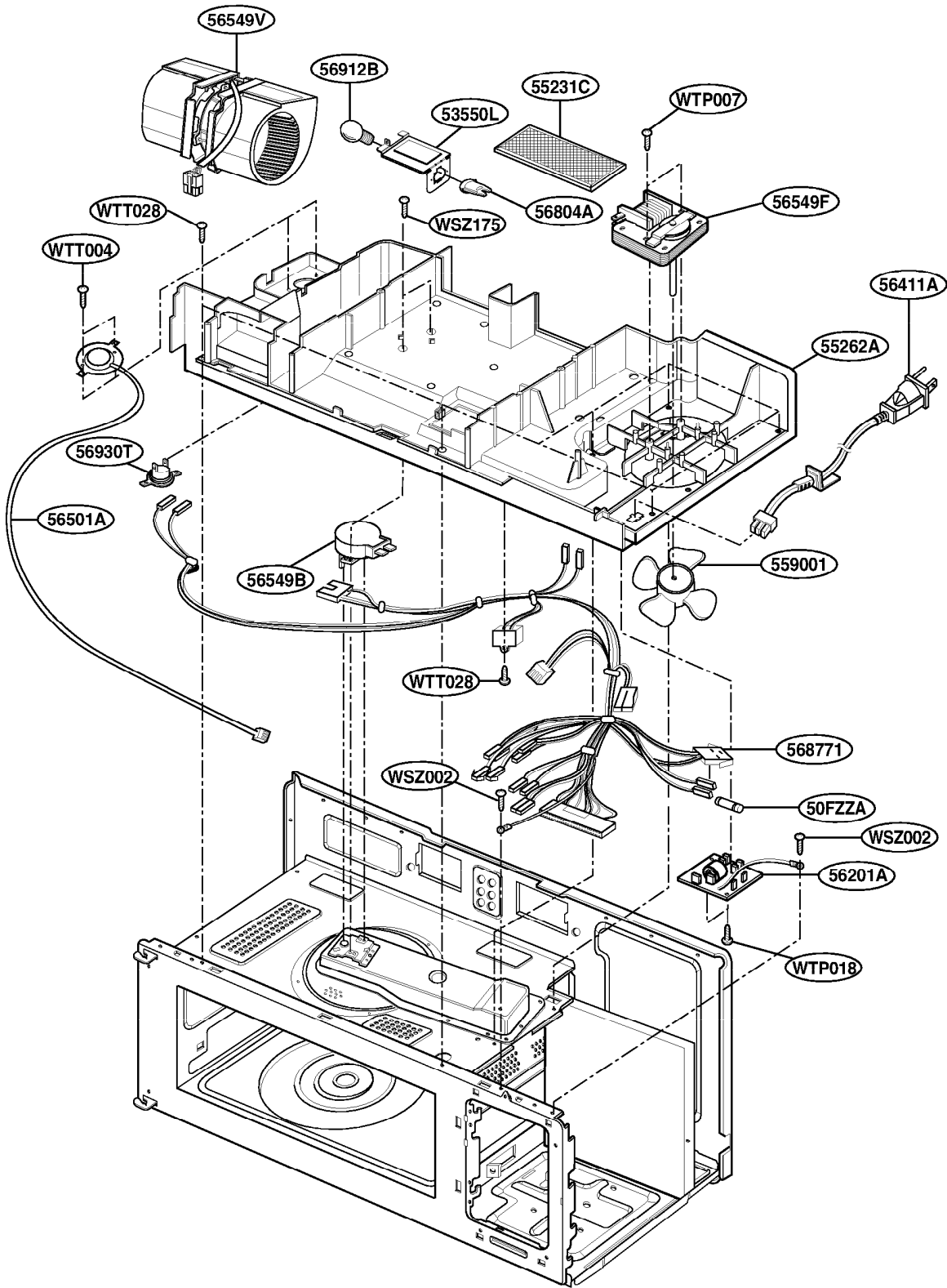

INSTALLATION PARTS

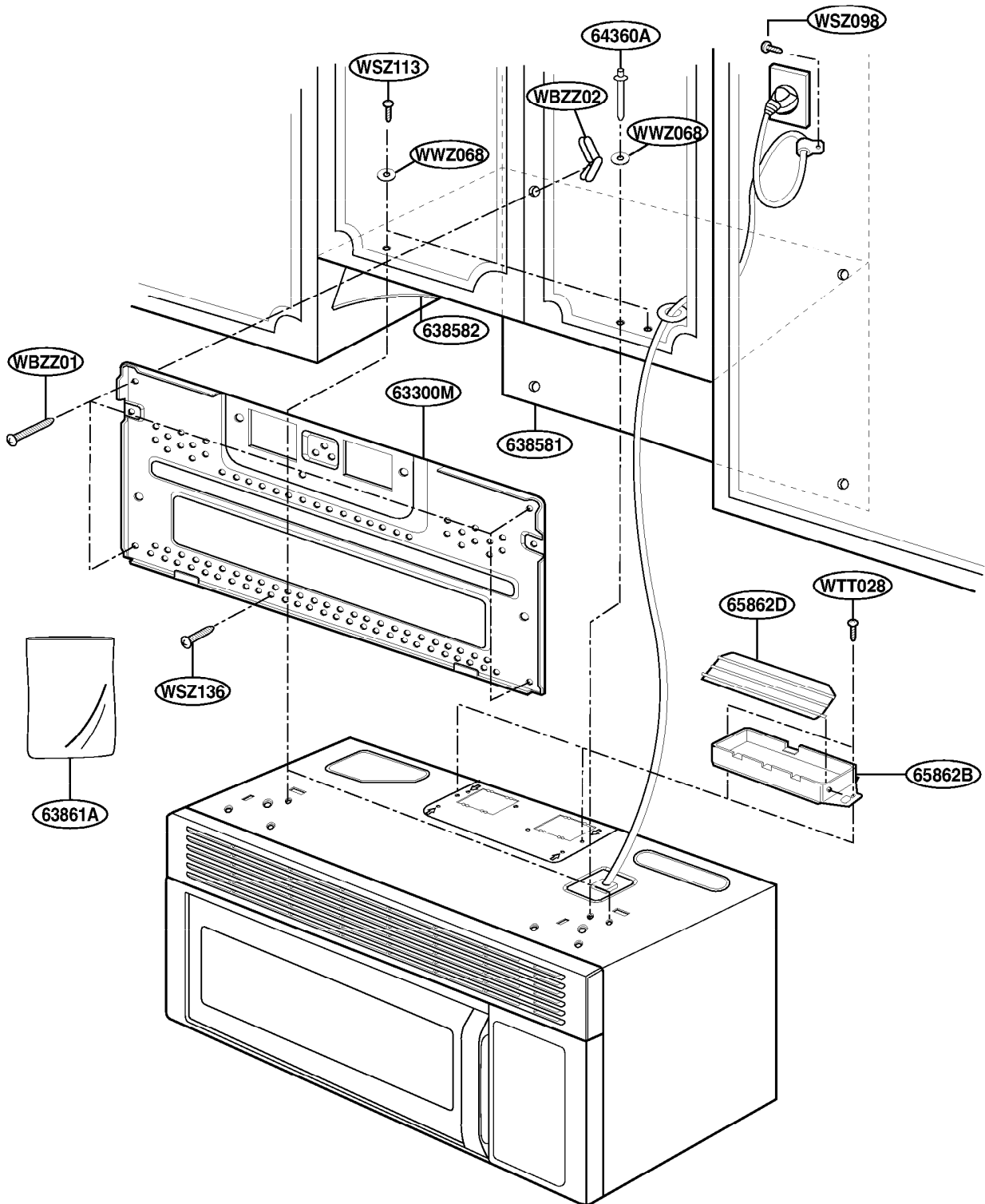

REPLACEMENT PARTS LIST

FOR MODEL 85910

LOC. NO.	PART NO.	DESCRIPTION	SVC
13213A	3213W1A035C	DOOR FRAME ASSY	R
13536A	3536WRA001R	SEAL TAPE	R
13552A	3552W1A032A	CHOKE COVER	R
13581A	3581W1A160K	DOOR ASSY,GROSS	R
13650A	3650W1A026A	HANDLE	R
13720D	3720W0D107A	PANEL,DOOR	R
14026A	4026W2A015B	LATCH	R
14890A	4890W1D042L	GLASS	R
14970A	4970WRA001A	SPRING	R
23572A	3572W1A141A	CONTROL PANEL	R
24781M	4781W1M129S	CONTROLLER ASSY,MICOM	R
24810P	4810W1G061A	BRACKET,CONTROL PANEL	R
26638A	6638W2A239A	KEY MEMBRANE	R
268711	6871W2S090C	PWB(PCB) ASSY,SUB	R
30RMZZ	3B72552D	RESISTOR,CEMENT	R
33112U	3112W1U016A	OUT CASE,U-BENDING	R
33390G	1B71961A	TRAY,GLASS	R
33390G	1B71961A	TRAY,GLASS	R
33530A	3530W0A003A	GRILLE,VENT	R
33531A	3531W1A005A	GRILLE ASSY	R
33550P	3550W3A084A	COVER,POWER CORD	R
34030W	4036W3W001A	SEAL, WATER	R
340511	4051W3A001A	RIVET ASSY	R
34370T	4370W3A001A	SHAFT,MWO	R
34810R	4810W3G100A	BRACKET,COOKTOP	R
34890C	4890W4A001B	GLASS	R
34960A	4960W2G022B	MOUNT	R
34974A	4974W1G038A	AIR GUIDE	R
35026G	3750W1A006B	SHELF	R
35230A	2B72705B	FILTER(MECH)	R
35889A	5889W2A012A	ROTATING RING ASSY	R
36549S	2B72754K	MOTOR(CIRC),SYNCHRONOUS	R
36549S	6549W2S002H	MOTOR(CIRC),SYNCHRONOUS	*
36549S	6549WRS001N	MOTOR(CIRC),SYNCHRONOUS	*
368771	6877W3S001A	LEAD WIRE ASSY	R
36912C	6912W3Q001A	LAMP[OVEN/BASELESS]	R
43500A	3500W1A005A	BOARD,LATCH	R
435011	3501W1A016F	BOARD ASSY,LATCH	R
44510A	4510W4A005A	LEVER	R
466001	3B73362E	SWITCH,MICRO	R
466001	3B73362F	SWITCH,MICRO	*

R : SERVICE PARTS
 * : ALTERNATE PARTS
 N : NOT SERVICE PARTS

LOC. NO.	PART NO.	DESCRIPTION	SVC
466002	3B73362E	SWITCH,MICRO	R
466002	3B73362F	SWITCH,MICRO	*
466003	3B73361D	SWITCH,MICRO	R
466003	3B73361E	SWITCH,MICRO	*
50CZZH	0CZZW1H001E	CAPACITOR[HIGH VOLTAGE]	R
50CZZH	6120W3H003H	CAPACITOR[HIGH VOLTAGE]	*
50CZZH	6120WRH001G	CAPACITOR[HIGH VOLTAGE]	*
50FZZA	3B74133H	FUSE[ALL]	R
53300B	3300W1G081A	PLATE,BOTTOM	R
53550F	3550W1A077A	COVER,STIRRER FAN	R
53550L	3550W3A082A	COVER,LAMP	R
54810C	4810W3C002A	BRACKET,HVC	R
54810Q	4810W3G062A	BRACKET,MOUNT	R
54930F	4930W3B026B	HOLDER,STIRRER FAN	R
55231C	2B72706C	FILTER ASSY,CHARCOAL	R
55262A	5262W0A008A	AIR DUCT	R
55892A	5892W3A004A	STIRRER FAN	R
559001	2B72125A	FAN	R
560211	6021W3B001A	CABLE ASSY,DIODE	R
56170D	6170W1D002B	TRANSFORMER,HIGH VOLTAGE	R
56201A	2B72130F	FILTER ASSY,NOISE	R
56201B	6201W2A019A	FILTER ASSY,CHOKE	R
56324A	6324W1A001D	MAGNETRON	R
56411A	6411W2A002N	POWER CORD ASSY	R
56411A	6411W2A002P	POWER CORD ASSY	*
56549B	2B72754L	MOTOR(CIRC),SYNCHRONOUS	R
56549B	6549WRS001K	MOTOR(CIRC),SYNCHRONOUS	*
56549F	6549W2F016D	MOTOR(CIRC),FAN	R
56549V	6549W1V001J	MOTOR(CIRC),VENTILATION	R
56804A	6804W3A001A	LAMP HOLDER	R
568771	6877W1A169B	LEAD WIRE ASSY	R
568772	6877W2S002C	LEAD WIRE ASSY	R
56912B	3B70067A	LAMP[OVEN/BASELESS]	R
56930T	6930W3A001G	THERMOSTAT,BIMETAL	R
56930T	6930WRT003C	THERMOSTAT,BIMETAL	*
56930T	6930WRT004C	THERMOSTAT,BIMETAL	*
56930V	3B70068V	THERMOSTAT,BIMETAL	R
56930V	6930WRT003A	THERMOSTAT,BIMETAL	*
56930V	6930WRT004A	THERMOSTAT,BIMETAL	*
63300M	3300W0G039A	PLATE,MOUNTING	R
633021	3302W0A013A	BASE PLATE	R
63303A	3303W1A041F	BASE PLATE ASSY	R

R : SERVICE PARTS
* : ALTERNATE PARTS
N : NOT SERVICE PARTS

LOC. NO.	PART NO.	DESCRIPTION	SVC
638581	3858W5A017B	SHEET (MECH)	R
638582	3858W5A018C	SHEET (MECH)	R
63861A	2B72771A	KIT ASSY	R
64360A	4360W4A001A	ROD	R
65862B	3B72144A	EXHAUST,ADAPTER	R
65862D	3B71432A	EXHAUST,DAMPER	R
*01	3828W5A1123	MANUAL,OWNERS(MWO)	R
*01	3829W1A002X	MANUAL ASSY	*
*02	3828W5S1061	MANUAL,SERVICE	R
*03	3878W5B0010	COOK BOOK	R
*04	3828W5U0047	MANUAL,INSTALLATION	R
*05	3850W2A233A	LABEL,COOKING GUIDE	R
*07	3858W3T015N	CARD,TECHNICAL	R
WBZZ01	4B72059B	TOGGLE BOLT/WINGS	R
WBZZ02	4B72059C	TOGGLE BOLT	R
WSZ002	1SBF0402418	SCREW TAP TITE(S),BINDING HEAD	R
WSZ005	1SPF0302018	SCREW TAP TITE(S),PAN HEAD	R
WSZ084	4B70188B	SCREW	R
WSZ098	4B70637B	SCREW	R
WSZ113	4B73234A	SCREW	R
WSZ136	4B73243A	SCREW	R
WSZ137	4B73763A	SCREW	R
WSZ175	4E55432A	SCREW	R
WTP002	1TPL0302018	SCREW TAPPING,PAN HEAD	R
WTP004	1TPL0302418	SCREW TAPPING,PAN HEAD	R
WTP013	1TPL0402418	SCREW TAPPING,PAN HEAD	R
WTP018	1TPL0402818	SCREW TAPPING,PAN HEAD	R
WTT021	1TTL0402418	SCREW TAPPING,TRUSS HEAD	R
WTT022	1TTL0402422	SCREW TAPPING,TRUSS HEAD	R
WTT028	1TTL0402818	SCREW TAPPING,TRUSS HEAD	R
WTT029	1TTL0402822	SCREW TAPPING,TRUSS HEAD	R
WTT033	1TTL0403318	SCREW TAPPING,TRUSS HEAD	R
WWZ068	4B73055A	WASHER	R

R : SERVICE PARTS
* : ALTERNATE PARTS
N : NOT SERVICE PARTS

FOR MODEL 85919

LOC. NO.	PART NO.	DESCRIPTION	SVC
13213A	3213W1A035D	DOOR FRAME ASSY	R
13536A	3536WRA001R	SEAL TAPE	R
13552A	3552W1A032B	CHOKE COVER	R
13581A	3581W1A160L	DOOR ASSY,GROSS	R
13650A	3650W1A026B	HANDLE	R
13720D	3720W0D107B	PANEL,DOOR	R
14026A	4026W2A015A	LATCH	R
14890A	4890W1D042M	GLASS	R
14970A	4970WRA001A	SPRING	R
23572A	3572W1A141B	CONTROL PANEL	R
24781M	4781W1M129T	CONTROLLER ASSY,MICOM	R
24810P	4810W1G061A	BRACKET,CONTROL PANEL	R
26638A	6638W2A239B	KEY MEMBRANE	R
268711	6871W2S090C	PWB(PCB) ASSY,SUB	R
30RMZZ	3B72552D	RESISTOR,CEMENT	R
33112U	3112W1U016B	OUT CASE,U-BENDING	R
33390G	1B71961A	TRAY,GLASS	R
33530A	3530W0A003B	GRILLE,VENT	R
33531A	3531W1A005B	GRILLE ASSY	R
33550P	3550W3A084A	COVER,POWER CORD	R
34030W	4036W3W001A	SEAL, WATER	R
340511	4051W3A001A	RIVET ASSY	R
34370T	4370W3A001A	SHAFT,MWO	R
34810Q	4810W3G062A	BRACKET,MOUNT	R
34810R	4810W3G100B	BRACKET,COOKTOP	R
34890C	4890W4A001B	GLASS	R
34960A	4960W2G022B	MOUNT	R
34974A	4974W1G038A	AIR GUIDE	R
35026G	3750W1A006B	SHELF	R
35230A	2B72705B	FILTER(MECH)	R
35889A	5889W2A012A	ROTATING RING ASSY	R
36549S	2B72754K	MOTOR(CIRC),SYNCHRONOUS	R
36549S	6549W2S002H	MOTOR(CIRC),SYNCHRONOUS	*
36549S	6549WRS001N	MOTOR(CIRC),SYNCHRONOUS	*
36549V	6549W1V001J	MOTOR(CIRC),VENTILATION	R
368771	6877W3S001A	LEAD WIRE ASSY	R
36912C	6912W3Q001A	LAMP[OVEN/BASELESS]	R
43500A	3500W1A005A	BOARD,LATCH	R
435011	3501W1A016F	BOARD ASSY,LATCH	R
44510A	4510W4A005A	LEVER	R
466001	3B73362E	SWITCH,MICRO	R
466001	3B73362F	SWITCH,MICRO	*

R : SERVICE PARTS
 * : ALTERNATE PARTS
 N : NOT SERVICE PARTS

LOC. NO.	PART NO.	DESCRIPTION	SVC
466002	3B73362E	SWITCH,MICRO	R
466002	3B73362F	SWITCH,MICRO	*
466003	3B73361D	SWITCH,MICRO	R
466003	3B73361E	SWITCH,MICRO	*
50CZZH	0CZZW1H001E	CAPACITOR[HIGH VOLTAGE]	R
50CZZH	6120W3H003H	CAPACITOR[HIGH VOLTAGE]	*
50CZZH	6120WRH001G	CAPACITOR[HIGH VOLTAGE]	*
50FZZA	3B74133H	FUSE[ALL]	R
53300B	3300W1G081A	PLATE,BOTTOM	R
53550F	3550W1A077A	COVER,STIRRER FAN	R
53550L	3550W3A082A	COVER,LAMP	R
54810C	4810W3C002A	BRACKET,HVC	R
54930F	4930W3B026B	HOLDER,STIRRER FAN	R
55231C	2B72706C	FILTER ASSY,CHARCOAL	R
55262A	5262W0A008A	AIR DUCT	R
558921	5892W3A004A	STIRRER FAN	R
559001	2B72125A	FAN	R
560211	6021W3B001A	CABLE ASSY,DIODE	R
56170D	6170W1D002B	TRANSFORMER,HIGH VOLTAGE	R
56201A	2B72130F	FILTER ASSY,NOISE	R
56201B	6201W2A019A	FILTER ASSY,CHOKE	R
56324A	6324W1A001D	MAGNETRON	R
56411A	6411W2A002N	POWER CORD ASSY	R
56411A	6411W2A002P	POWER CORD ASSY	*
56411A	6411W2A002Q	POWER CORD ASSY	*
56549B	2B72754L	MOTOR(CIRC),SYNCHRONOUS	R
56549B	6549WRS001K	MOTOR(CIRC),SYNCHRONOUS	*
56549F	6549W2F016D	MOTOR(CIRC),FAN	R
56804A	6804W3A001A	LAMP HOLDER	R
568771	6877W1A169B	LEAD WIRE ASSY	R
568772	6877W2S002C	LEAD WIRE ASSY	R
56912B	3B70067A	LAMP[OVEN/BASELESS]	R
56930M	6930WRT003A	THERMOSTAT,BIMETAL	R
56930M	6930WRT004A	THERMOSTAT,BIMETAL	R
56930T	6930W3A001G	THERMOSTAT,BIMETAL	R
56930T	6930WRT003C	THERMOSTAT,BIMETAL	*
56930T	6930WRT004C	THERMOSTAT,BIMETAL	*
56930V	3B70068V	THERMOSTAT,BIMETAL	R
63300M	3300W0G039A	PLATE,MOUNTING	R
633021	3302W0A013B	BASE PLATE	R

R : SERVICE PARTS
* : ALTERNATE PARTS
N : NOT SERVICE PARTS

LOC. NO.	PART NO.	DESCRIPTION	SVC
63303A	3303W1A041G	BASE PLATE ASSY	R
638581	3858W5A017B	SHEET (MECH)	R
638582	3858W5A018C	SHEET (MECH)	R
63861A	2B72771A	KIT ASSY	R
64360A	4360W4A001A	ROD	R
65862B	3B72144A	EXHAUST,ADAPTER	R
65862D	3B71432A	EXHAUST,DAMPER	R
*01	3828W5A1123	MANUAL,OWNERS(MWO)	R
*01	3829W1A002X	MANUAL ASSY	*
*02	3828W5S1061	MANUAL,SERVICE	R
*03	3878W5B0010	COOK BOOK	R
*04	3828W5U0047	MANUAL,INSTALLATION	R
*05	3850W2A233A	LABEL,COOKING GUIDE	R
*07	3858W3T015N	CARD,TECHNIACL	R
WBZZ01	4B72059B	TOGGLE BOLT/WINGS	R
WBZZ02	4B72059C	TOGGLE BOLT	R
WSZ002	1SBF0402418	SCREW TAP TITE(S),BINDING HEAD	R
WSZ005	1SPF0302018	SCREW TAP TITE(S),PAN HEAD	R
WSZ084	4B70188B	SCREW	R
WSZ098	4B70637B	SCREW	R
WSZ113	4B73234A	SCREW	R
WSZ136	4B73243A	SCREW	R
WSZ137	4B73763A	SCREW	R
WSZ175	4E55432A	SCREW	R
WTP002	1TPL0302018	SCREW TAPPING,PAN HEAD	R
WTP013	1TPL0402418	SCREW TAPPING,PAN HEAD	R
WTP018	1TPL0402818	SCREW TAPPING,PAN HEAD	R
WTT020	1TTL0402416	SCREW TAPPING,TRUSS HEAD	R
WTT021	1TTL0402418	SCREW TAPPING,TRUSS HEAD	R
WTT027	1TTL0402816	SCREW TAPPING,TRUSS HEAD	R
WTT028	1TTL0402818	SCREW TAPPING,TRUSS HEAD	R
WTT033	1TTL0403318	SCREW TAPPING,TRUSS HEAD	R
WWZ068	4B73055A	WASHER	R

R : SERVICE PARTS
* : ALTERNATE PARTS
N : NOT SERVICE PARTS

FOR MODEL 85970

LOC. NO.	PART NO.	DESCRIPTION	SVC
13213A	3213W1A035C	DOOR FRAME ASSY	R
13536A	3536WRA001R	SEAL TAPE	R
13552A	3552W1A032A	CHOKE COVER	R
13581A	3581W1A160K	DOOR ASSY,GROSS	R
13650A	3650W1A026A	HANDLE	R
13720D	3720W0D107A	PANEL,DOOR	R
14026A	4026W2A015B	LATCH	R
14890A	4890W1D042L	GLASS	R
14970A	4970WRA001A	SPRING	R
23572A	3572W1A141A	CONTROL PANEL	R
24781M	4781W1M129U	CONTROLLER ASSY,MICOM	R
24810P	4810W1G061A	BRACKET,CONTROL PANEL	R
26638A	6638W2A240A	KEY MEMBRANE	R
268711	6871W2S090A	PWB(PCB) ASSY,SUB	R
30RMZZ	3B72552D	RESISTOR,CEMENT	R
33112U	3112W1U016A	OUT CASE,U-BENDING	R
33390G	1B71961A	TRAY,GLASS	R
33390G	1B71961A	TRAY,GLASS	R
33530A	3530W0A003A	GRILLE,VENT	R
33531A	3531W1A005A	GRILLE ASSY	R
33550P	3550W3A084A	COVER,POWER CORD	R
34030W	4036W3W001A	SEAL, WATER	R
340511	4051W3A001A	RIVET ASSY	R
34370T	4370W3A001A	SHAFT,MWO	R
34810R	4810W3G100A	BRACKET,COOKTOP	R
34890C	4890W4A001B	GLASS	R
34960A	4960W2G022B	MOUNT	R
34974A	4974W1G038A	AIR GUIDE	R
35026G	3750W1A006B	SHELF	R
35230A	2B72705B	FILTER(MECH)	R
35889A	5889W2A012A	ROTATING RING ASSY	R
36549S	2B72754K	MOTOR(CIRC),SYNCHRONOUS	R
36549S	6549W2S002H	MOTOR(CIRC),SYNCHRONOUS	*
36549S	6549WRS001N	MOTOR(CIRC),SYNCHRONOUS	*
368771	6877W3S001A	LEAD WIRE ASSY	R
36912C	6912W3Q001A	LAMP[OVEN/BASELESS]	R
43500A	3500W1A005A	BOARD,LATCH	R
435011	3501W1A016F	BOARD ASSY,LATCH	R
44510A	4510W4A005A	LEVER	R
466001	3B73362E	SWITCH,MICRO	R
466001	3B73362F	SWITCH,MICRO	*

R : SERVICE PARTS
 * : ALTERNATE PARTS
 N : NOT SERVICE PARTS

LOC. NO.	PART NO.	DESCRIPTION	SVC
466002	3B73362E	SWITCH,MICRO	R
466002	3B73362F	SWITCH,MICRO	*
466003	3B73361D	SWITCH,MICRO	R
466003	3B73361E	SWITCH,MICRO	*
50CZZH	0CZZW1H001E	CAPACITOR[HIGH VOLTAGE]	R
50CZZH	6120W3H003H	CAPACITOR[HIGH VOLTAGE]	*
50CZZH	6120WRH001G	CAPACITOR[HIGH VOLTAGE]	*
50FZZA	3B74133H	FUSE[ALL]	R
53300B	3300W1G081A	PLATE,BOTTOM	R
53550F	3550W1A077A	COVER,STIRRER FAN	R
53550L	3550W3A082A	COVER,LAMP	R
54810C	4810W3C002A	BRACKET,HVC	R
54810Q	4810W3G062A	BRACKET,MOUNT	R
54930F	4930W3B026B	HOLDER,STIRRER FAN	R
55231C	2B72706C	FILTER ASSY,CHARCOAL	R
55262A	5262W0A008A	AIR DUCT	R
55892A	5892W3A004A	STIRRER FAN	R
559001	2B72125A	FAN	R
560211	6021W3B001A	CABLE ASSY,DIODE	R
56170D	6170W1D002B	TRANSFORMER,HIGH VOLTAGE	R
56201A	2B72130F	FILTER ASSY,NOISE	R
56201B	6201W2A019A	FILTER ASSY,CHOKE	R
56324A	6324W1A001D	MAGNETRON	R
56411A	6411W2A002N	POWER CORD ASSY	R
56411A	6411W2A002P	POWER CORD ASSY	*
56501A	6501W1A004A	SENSOR ASSY	R
56549B	2B72754L	MOTOR(CIRC),SYNCHRONOUS	R
56549B	6549WRS001K	MOTOR(CIRC),SYNCHRONOUS	*
56549F	6549W2F016D	MOTOR(CIRC),FAN	R
56549V	6549W1V001J	MOTOR(CIRC),VENTILATION	R
56804A	6804W3A001A	LAMP HOLDER	R
568771	6877W1A169B	LEAD WIRE ASSY	R
568772	6877W2S002C	LEAD WIRE ASSY	R
56912B	3B70067A	LAMP[OVEN/BASELESS]	R
56930T	6930W3A001G	THERMOSTAT,BIMETAL	R
56930T	6930WRT003C	THERMOSTAT,BIMETAL	*
56930T	6930WRT004C	THERMOSTAT,BIMETAL	*
56930V	3B70068V	THERMOSTAT,BIMETAL	R
56930V	6930WRT003A	THERMOSTAT,BIMETAL	*
56930V	6930WRT004A	THERMOSTAT,BIMETAL	*
63300M	3300W0G039A	PLATE,MOUNTING	R
633021	3302W0A013A	BASE PLATE	R
63303A	3303W1A041F	BASE PLATE ASSY	R

R : SERVICE PARTS
* : ALTERNATE PARTS
N : NOT SERVICE PARTS

LOC. NO.	PART NO.	DESCRIPTION	SVC
638581	3858W5A017B	SHEET (MECH)	R
638582	3858W5A018C	SHEET (MECH)	R
63861A	2B72771A	KIT ASSY	R
64360A	4360W4A001A	ROD	R
65862B	3B72144A	EXHAUST,ADAPTER	R
65862D	3B71432A	EXHAUST,DAMPER	R
*01	3828W5A1124	MANUAL,OWNERS(MWO)	R
*01	3829W1A002Y	MANUAL ASSY	*
*02	3828W5S1061	MANUAL,SERVICE	R
*03	3878W5B0010	COOK BOOK	R
*03	3B72485A	CARD,ALL	*
*04	3828W5U0047	MANUAL,INSTALLATION	R
*05	3850W2A233R	LABEL,COOKING GUIDE	R
*07	3858W3T015N	CARD,TECHNICAL	R
WBZZ01	4B72059B	TOGGLE BOLT/WINGS	R
WBZZ02	4B72059C	TOGGLE BOLT	R
WSZ002	1SBF0402418	SCREW TAP TITE(S),BINDING HEAD	R
WSZ005	1SPF0302018	SCREW TAP TITE(S),PAN HEAD	R
WSZ084	4B70188B	SCREW	R
WSZ098	4B70637B	SCREW	R
WSZ113	4B73234A	SCREW	R
WSZ136	4B73243A	SCREW	R
WSZ137	4B73763A	SCREW	R
WSZ175	4E55432A	SCREW	R
WTP002	1TPL0302018	SCREW TAPPING,PAN HEAD	R
WTP004	1TPL0302418	SCREW TAPPING,PAN HEAD	R
WTP013	1TPL0402418	SCREW TAPPING,PAN HEAD	R
WTP018	1TPL0402818	SCREW TAPPING,PAN HEAD	R
WTT021	1TTL0402418	SCREW TAPPING,TRUSS HEAD	R
WTT022	1TTL0402422	SCREW TAPPING,TRUSS HEAD	R
WTT028	1TTL0402818	SCREW TAPPING,TRUSS HEAD	R
WTT029	1TTL0402822	SCREW TAPPING,TRUSS HEAD	R
WTT033	1TTL0403318	SCREW TAPPING,TRUSS HEAD	R
WWZ068	4B73055A	WASHER	R

R : SERVICE PARTS
* : ALTERNATE PARTS
N : NOT SERVICE PARTS

SCHEMATIC DIAGRAM OF P.C.B

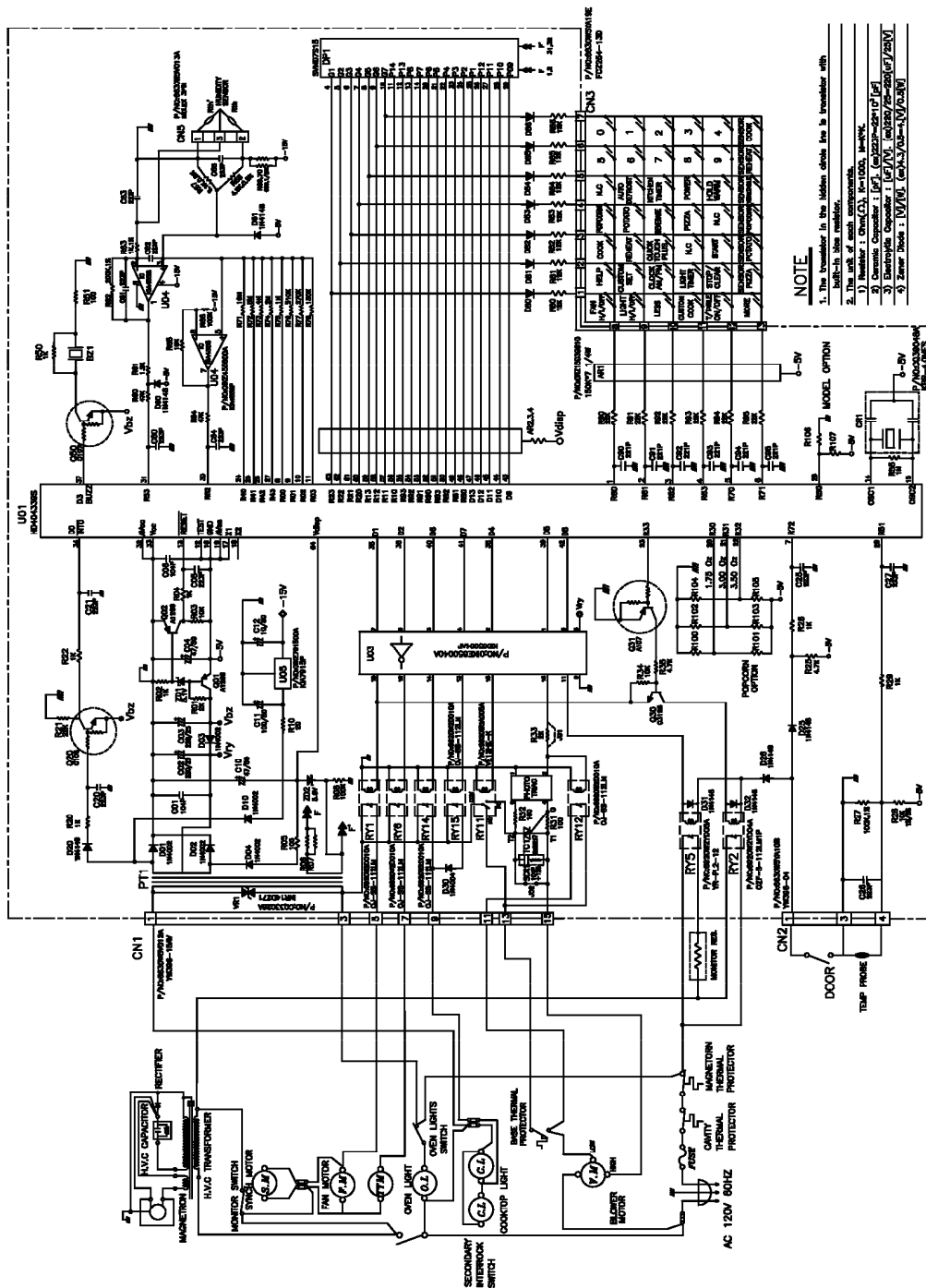

PRINTED CIRCUIT BOARD

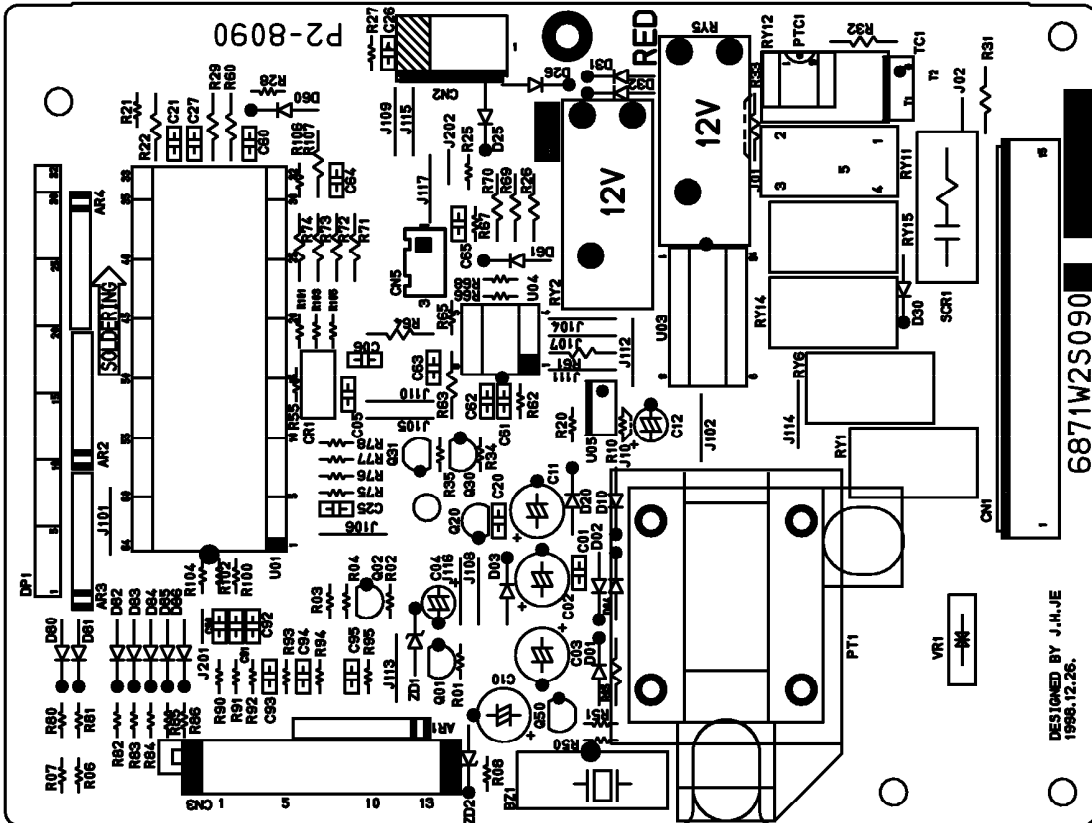
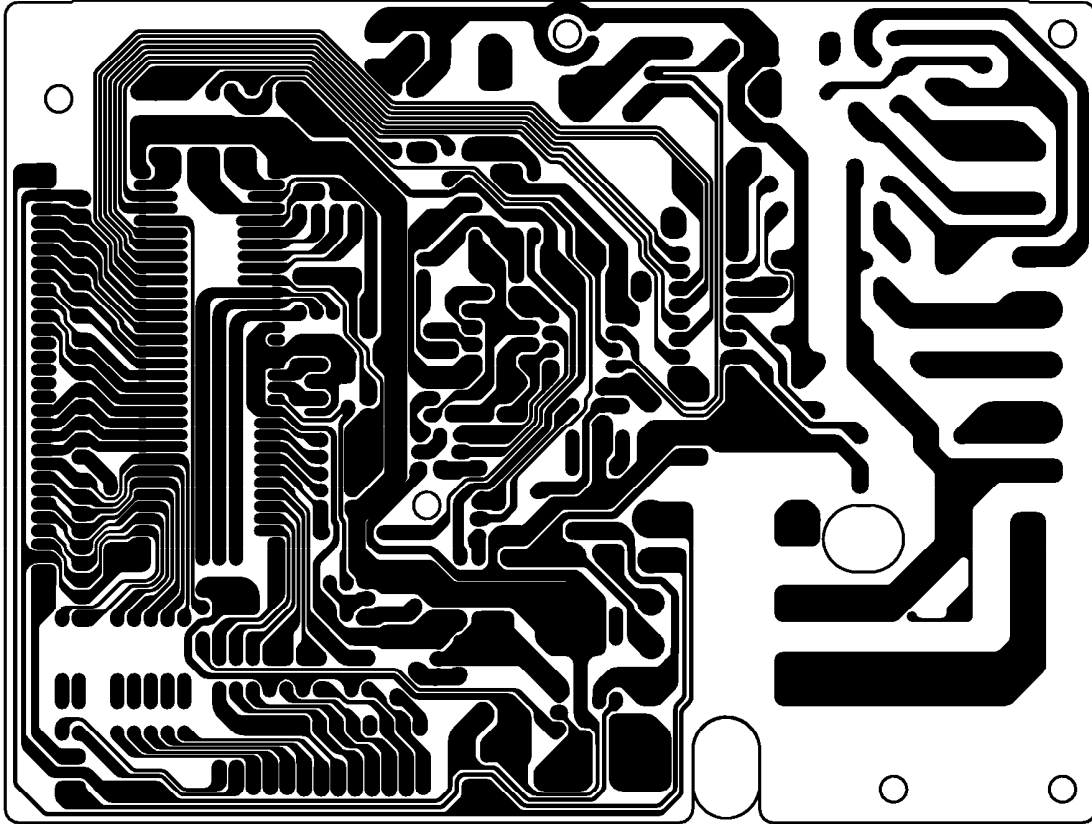

P.C.B. PARTS LIST

FOR MODEL 85910, 85919

LOC. NO.	PART NO.	DESCRIPTION	SPECIFICATION	SVC
BZ1	6908W3YA01A	BUZZER,PIEZO CERAMIC	GPB-B-26B2.1ES(EXTERNAL)	R
C02	0CE2272H638	CAPACITOR,AL.ELECTROLYTIC	220UF SME 25V	R
C03	0CE2272H638	CAPACITOR,AL.ELECTROLYTIC	220UF SME 25V	R
C04	0CE4761K638	CAPACITOR,AL.ELECTROLYTIC	47UF SM,SA 50V	R
C10	0CE4761K638	CAPACITOR,AL.ELECTROLYTIC	47UF SM,SA 50V	R
C01	0CK1040K518	CAPACITOR,CERAMIC (HIGH DIELECTRIC)	0.1000UF 50V	R
C05	0CK2230H518	CAPACITOR,CERAMIC (HIGH DIELECTRIC)	0.0220UF 25V	R
C06	0CK1040K518	CAPACITOR,CERAMIC (HIGH DIELECTRIC)	0.1000UF 50V	R
C20	0CK2230H518	CAPACITOR,CERAMIC (HIGH DIELECTRIC)	0.0220UF 25V	R
C21	0CK2230H518	CAPACITOR,CERAMIC (HIGH DIELECTRIC)	0.0220UF 25V	R
C25	0CK2230H518	CAPACITOR,CERAMIC (HIGH DIELECTRIC)	0.0220UF 25V	R
CR1	CQ39048A	CERAMIC RESONATOR	KBR-4.0MES/CST4.00MGW	R
CN1	6630W5V012A	CONNECTOR (CIRC),WAFER	YW396-15AV(2,4,....,14VOID)	R
CN2	CQ52212A	CONNECTOR (CIRC),WAFER	YW396-03,#2 VOID	R
CN2	6630W5V004A	CONNECTOR (CIRC),WAFER	JE202A-1T-2(3-2),JAE EUN,WH	*
CN3	6630W5YA19E	CONNECTOR (CIRC),WAFER	FCZ254-13D	R
CN3	6630W5V017D	CONNECTOR (CIRC),WAFER	JE501S JAE-EUN 13P 2.54MM	*
CU1	4850W4C001A	CUSHION	3.5MM	R
DP1	6302W5A002A	DIGITRON	SVM-07SS15, 7-MT-213GN	R
D01	0DD400209AA	DIODE,RECTIFIER	1N4002	R
D02	0DD400209AA	DIODE,RECTIFIER	1N4002	R
D03	0DD400209AA	DIODE,RECTIFIER	1N4002	R
D04	0DD400209AA	DIODE,RECTIFIER	1N4002	R
D30	0DD400409AA	DIODE,RECTIFIER	1N4004TA	R
D20	0DD414809AA	DIODE,SWITCHING	1N4148	R
D25	0DD414809AA	DIODE,SWITCHING	1N4148	R
D26	0DD414809AA	DIODE,SWITCHING	1N4148	R
D31	0DD414809AA	DIODE,SWITCHING	1N4148	R
D32	0DD414809AA	DIODE,SWITCHING	1N4148	R
D80	0DD414809AA	DIODE,SWITCHING	1N4148	R
D81	0DD414809AA	DIODE,SWITCHING	1N4148	R
D82	0DD414809AA	DIODE,SWITCHING	1N4148	R
D83	0DD414809AA	DIODE,SWITCHING	1N4148	R
D84	0DD414809AA	DIODE,SWITCHING	1N4148	R
D85	0DD414809AA	DIODE,SWITCHING	1N4148	R
D86	0DD414809AA	DIODE,SWITCHING	1N4148	R
ZD1	0DZ510009AB	DIODE,ZENER	MTZ5.1B(TA)	R
ZD2	0DZ560009AB	DIODE,ZENER	UZ-5.6BS 0.5W	R
U01	6000W5YA40A	IC	HD4074339S	R
U03	0IKE650040A	IC,KEC	KID65004AP	R
RY1	6920W2D010A	RELAY	OJ-SS-112LM	R
RY1	6920W2D010B	RELAY	CS11-12SH	*
RY11	6920W5A005A	RELAY	VE-12HE-K	R
RY12	6920W2D010A	RELAY	OJ-SS-112LM	R
RY12	6920W2D010B	RELAY	CS11-12SH	*
RY14	6920W2D010A	RELAY	OJ-SS-112LM	R
RY14	6920W2D010B	RELAY	CS11-12SH	*
RY15	6920W2D010A	RELAY	OJ-SS-112LM	R
RY15	6920W2D010B	RELAY	CS11-12SH	*
RY2	6920W2YD04A	RELAY	OZF-S-112LM1P	R
RY5	6920W2YD05A	RELAY	YR-PL2-12/CS-1PD	R

R : SERVICE PARTS
 * : ALTERNATE PARTS
 N : NOT SERVICE PARTS

LOC. NO.	PART NO.	DESCRIPTION	SPECIFICATION	SVC
RY6	6920W2D010A	RELAY	OJ-SS-112LM	R
RY6	6920W2D010B	RELAY	CS11-12SH	*
AR1	0RZ1503G610	RESISTOR,ARRAY	SMART 150KOHM 5% 8PIN	R
AR2	0RZ4702G610	RESISTOR,ARRAY	SMART 47KOHM 5% 8	R
AR3	0RZ4702G610	RESISTOR,ARRAY	SMART 47KOHM 5% 8	R
AR4	0RZ4702G610	RESISTOR,ARRAY	SMART 47KOHM 5% 8	R
R01	0RD2001F608	RESISTOR,FIXED CARBON FILM	2K 1/6W	R
R02	0RD1001F608	RESISTOR,FIXED CARBON FILM	1.0K 1/6W	R
R03	0RD1002F608	RESISTOR,FIXED CARBON FILM	10K 1/6W	R
R04	0RD1001F608	RESISTOR,FIXED CARBON FILM	1.0K 1/6W	R
R05	0RD1000G608	RESISTOR,FIXED CARBON FILM	100 OHM 1/4 W	R
R06	0RD0202F608	RESISTOR,FIXED CARBON FILM	20 1/6W	R
R07	0RD0202F608	RESISTOR,FIXED CARBON FILM	20 1/6W	R
R08	0RD1003F608	RESISTOR,FIXED CARBON FILM	100K 1/6W	R
R100	0RD3302F608	RESISTOR,FIXED CARBON FILM	33K 1/6W	R
R101	0RD1202F608	RESISTOR,FIXED CARBON FILM	12K 1/6W	R
R102	0RD3302F608	RESISTOR,FIXED CARBON FILM	33K 1/6W	R
R103	0RD1202F608	RESISTOR,FIXED CARBON FILM	12K 1/6W	R
R104	0RD2202F608	RESISTOR,FIXED CARBON FILM	22K 1/6W	R
R105	0RD1202F608	RESISTOR,FIXED CARBON FILM	12K 1/6W	R
R106	0RD4702F608	RESISTOR,FIXED CARBON FILM	47K 1/6W	R
R107	0RD1002G608	RESISTOR,FIXED CARBON FILM	10K OHM 1/4 W	R
R20	0RD1001F608	RESISTOR,FIXED CARBON FILM	1.0K 1/6W	R
R21	0RD2202F608	RESISTOR,FIXED CARBON FILM	22K 1/6W	R
R22	0RD1001G608	RESISTOR,FIXED CARBON FILM	1K OHM 1/4 W	R
R26	0RD1001G608	RESISTOR,FIXED CARBON FILM	1K OHM 1/4 W	R
R28	0RD1002F608	RESISTOR,FIXED CARBON FILM	10K 1/6W	R
R29	0RD1001G608	RESISTOR,FIXED CARBON FILM	1K OHM 1/4W	R
R34	0RD1002F608	RESISTOR,FIXED CARBON FILM	10K 1/6W	R
R35	0RD4701F608	RESISTOR,FIXED CARBON FILM	4.7K 1/6W	R
R50	0RD1001F608	RESISTOR,FIXED CARBON FILM	1.0K 1/6W	R
R51	0RD1000F608	RESISTOR,FIXED CARBON FILM	100 1/6W	R
R55	0RD1004F608	RESISTOR,FIXED CARBON FILM	1.0M 1/6W	R
R80	0RD1202F608	RESISTOR,FIXED CARBON FILM	12K 1/6W	R
R81	0RD1202F608	RESISTOR,FIXED CARBON FILM	12K 1/6W	R
R82	0RD1202F608	RESISTOR,FIXED CARBON FILM	12K 1/6W	R
R83	0RD1202F608	RESISTOR,FIXED CARBON FILM	12K 1/6W	R
R84	0RD1202F608	RESISTOR,FIXED CARBON FILM	12K 1/6W	R
R85	0RD1202F608	RESISTOR,FIXED CARBON FILM	12K 1/6W	R
R86	0RD1202F608	RESISTOR,FIXED CARBON FILM	12K 1/6W	R
R90	0RD2202F608	RESISTOR,FIXED CARBON FILM	22K 1/6W	R
R91	0RD2202F608	RESISTOR,FIXED CARBON FILM	22K 1/6W	R
R92	0RD2202F608	RESISTOR,FIXED CARBON FILM	22K 1/6W	R
R93	0RD2202F608	RESISTOR,FIXED CARBON FILM	22K 1/6W	R
R94	0RD2202F608	RESISTOR,FIXED CARBON FILM	22K 1/6W	R
R95	0RD2202F608	RESISTOR,FIXED CARBON FILM	22K 1/6W	R
PT1	6010W2P043A	TRANSFORMER,POWER	120V/60HZ,144MA/12V	R
Q01	0TR101509AB	TRANSISTOR	A1015=KTA12660	R
Q02	0TR101509AB	TRANSISTOR	A1015=KTA12660	R
Q20	0TR106009AF	TRANSISTOR	KRC 106M KEC	R
Q30	0TR181509AB	TRANSISTOR	KTC1815-Y=KTC3198Y	R
Q31	0TR107009AE	TRANSISTOR	KRA107M	R
Q50	0TR107009AD	TRANSISTOR	KRC 107M	R
VR1	CQ33026A	VARISTOR	INR14D271	R

R : SERVICE PARTS
* : ALTERNATE PARTS
N : NOT SERVICE PARTS

FOR MODEL 85970

LOC. NO.	PART NO.	DESCRIPTION	SPECIFICATION	SVC
BZ1	6908W3YA01A	BUZZER,PIEZO CERAMIC	GPB-B-26B2.1ES(EXTERNAL)	R
C02	0CE2272H638	CAPACITOR,AL.ELECTROLYTIC	220UF SME 25V	R
C03	0CE2272H638	CAPACITOR,AL.ELECTROLYTIC	220UF SME 25V	R
C04	0CE4761K638	CAPACITOR,AL.ELECTROLYTIC	47UF SM,SA 50V	R
C10	0CE4761K638	CAPACITOR,AL.ELECTROLYTIC	47UF SM,SA 50V	R
C11	0CE1071K638	CAPACITOR,AL.ELECTROLYTIC	100UF SM 50V	R
C12	0CE1061K638	CAPACITOR,AL.ELECTROLYTIC	10UF SM 50V	R
C01	0CK1040K518	CAPACITOR,CERAMIC (HIGH DIELECTRIC)	0.1000UF 50V	R
C05	0CK2230H518	CAPACITOR,CERAMIC (HIGH DIELECTRIC)	0.0220UF 25V	R
C06	0CK1040K518	CAPACITOR,CERAMIC (HIGH DIELECTRIC)	0.1000UF 50V	R
C20	0CK2230H518	CAPACITOR,CERAMIC (HIGH DIELECTRIC)	0.0220UF 25V	R
C21	0CK2230H518	CAPACITOR,CERAMIC (HIGH DIELECTRIC)	0.0220UF 25V	R
C25	0CK2230H518	CAPACITOR,CERAMIC (HIGH DIELECTRIC)	0.0220UF 25V	R
C60	0CK2230H518	CAPACITOR,CERAMIC (HIGH DIELECTRIC)	0.0220UF 25V	R
C61	0CK2230H518	CAPACITOR,CERAMIC (HIGH DIELECTRIC)	0.0220UF 25V	R
C62	0CK2230H518	CAPACITOR,CERAMIC (HIGH DIELECTRIC)	0.0220UF 25V	R
C63	0CK2230H518	CAPACITOR,CERAMIC (HIGH DIELECTRIC)	0.0220UF 25V	R
C64	0CK2230H518	CAPACITOR,CERAMIC (HIGH DIELECTRIC)	0.0220UF 25V	R
C65	0CK2230H518	CAPACITOR,CERAMIC (HIGH DIELECTRIC)	0.0220UF 25V	R
CR1	CQ39048A	CERAMIC RESONATOR	KBR-4.0MES/CST4.00MGW	R
CN1	6630W5V012A	CONNECTOR (CIRC),WAFER	YW396-15AV(2,4,....,14VOID)	R
CN2	CQ52212A	CONNECTOR (CIRC),WAFER	YW396-03,#2 VOID	R
CN2	6630W5V004A	CONNECTOR (CIRC),WAFER	JE202A-1T-2(3-2),JAE EUN,WH	*
CN3	6630W5YA19E	CONNECTOR (CIRC),WAFER	FCZ254-13D	R
CN3	6630W5V017D	CONNECTOR (CIRC),WAFER	JE501S JAE-EUN 13P 2.54MM	*
CN5	6630W5V013A	CONNECTOR (CIRC),WAFER	MOLEX , 35312-0312 , 3PIN , RED	R
CU1	4850W4C001A	CUSHION	3.5MM	R
DP1	6302W5A002A	DIGITRON	SVM-07SS15, 7-MT-213GN	R
D01	0DD400209AA	DIODE,RECTIFIER	1N4002	R
D02	0DD400209AA	DIODE,RECTIFIER	1N4002	R
D03	0DD400209AA	DIODE,RECTIFIER	1N4002	R
D04	0DD400209AA	DIODE,RECTIFIER	1N4002	R
D10	0DD400209AA	DIODE,RECTIFIER	1N4002	R
D30	0DD400409AA	DIODE,RECTIFIER	1N4004TA	R
D20	0DD414809AA	DIODE,SWITCHING	1N4148	R
D25	0DD414809AA	DIODE,SWITCHING	1N4148	R
D26	0DD414809AA	DIODE,SWITCHING	1N4148	R
D31	0DD414809AA	DIODE,SWITCHING	1N4148	R
D32	0DD414809AA	DIODE,SWITCHING	1N4148	R
D60	0DD414809AA	DIODE,SWITCHING	1N4148	R
D61	0DD414809AA	DIODE,SWITCHING	1N4148	R
D80	0DD414809AA	DIODE,SWITCHING	1N4148	R
D81	0DD414809AA	DIODE,SWITCHING	1N4148	R
D82	0DD414809AA	DIODE,SWITCHING	1N4148	R
D83	0DD414809AA	DIODE,SWITCHING	1N4148	R
D84	0DD414809AA	DIODE,SWITCHING	1N4148	R
D85	0DD414809AA	DIODE,SWITCHING	1N4148	R
D86	0DD414809AA	DIODE,SWITCHING	1N4148	R
ZD1	0DZ510009AB	DIODE,ZENER	MTZ5.1B(TA)	R
ZD2	0DZ560009AB	DIODE,ZENER	UZ-5.6BS 0.5W	R

R : SERVICE PARTS
 * : ALTERNATE PARTS
 N : NOT SERVICE PARTS

LOC. NO.	PART NO.	DESCRIPTION	SPECIFICATION	SVC
U01	6000W5YA40A	IC	HD4074339S	R
U03	0IKE650040A	IC,KEC	KID65004AP	R
U04	0IKE455800A	IC,KEC	KIA4558P 8DIP LIN OP-AMP	R
U05	0IKE791500A	IC,KEC	KIA7915P/PI	R
RY1	6920W2D010A	RELAY	OJ-SS-112LM	R
RY1	6920W2D010B	RELAY	CS11-12SH	*
RY11	6920W5A005A	RELAY	VE-12HE-K	R
RY12	6920W2D010A	RELAY	OJ-SS-112LM	R
RY12	6920W2D010B	RELAY	CS11-12SH	*
RY14	6920W2D010A	RELAY	OJ-SS-112LM	R
RY14	6920W2D010B	RELAY	CS11-12SH	*
RY15	6920W2D010A	RELAY	OJ-SS-112LM	R
RY15	6920W2D010B	RELAY	CS11-12SH	*
RY2	6920W2YD04A	RELAY	OZF-S-112LM1P	R
RY5	6920W2YD05A	RELAY	YR-PL2-12/CS-1PD	R
RY6	6920W2D010A	RELAY	OJ-SS-112LM	R
RY6	6920W2D010B	RELAY	CS11-12SH	*
AR1	0RZ1503G610	RESISTOR,ARRAY	SMART 150KOHM 5% 8PIN	R
AR2	0RZ4702G610	RESISTOR,ARRAY	SMART 47KOHM 5% 8	R
AR3	0RZ4702G610	RESISTOR,ARRAY	SMART 47KOHM 5% 8	R
AR4	0RZ4702G610	RESISTOR,ARRAY	SMART 47KOHM 5% 8	R
R71	0RK1605A608	RESISTOR,FIX METAL OXIDE	16M OHM 1/2 W	R
R72	0RK8004A608	RESISTOR,FIX METAL OXIDE	8M OHM 1/2 W	R
R01	0RD2001F608	RESISTOR,FIXED CARBON FILM	2K 1/6W	R
R02	0RD1001F608	RESISTOR,FIXED CARBON FILM	1.0K 1/6W	R
R03	0RD1002F608	RESISTOR,FIXED CARBON FILM	10K 1/6W	R
R04	0RD1001F608	RESISTOR,FIXED CARBON FILM	1.0K 1/6W	R
R05	0RD1000G608	RESISTOR,FIXED CARBON FILM	100 OHM 1/4 W	R
R06	0RD0471F608	RESISTOR,FIXED CARBON FILM	4.70 1/6W	R
R07	0RD0471F608	RESISTOR,FIXED CARBON FILM	4.70 1/6W	R
R08	0RD1003F608	RESISTOR,FIXED CARBON FILM	100K 1/6W	R
R10	0RD0102F608	RESISTOR,FIXED CARBON FILM	10 1/6W	R
R101	0RD4702F608	RESISTOR,FIXED CARBON FILM	47K 1/6W	R
R103	0RD4702F608	RESISTOR,FIXED CARBON FILM	47K 1/6W	R
R105	0RD4702F608	RESISTOR,FIXED CARBON FILM	47K 1/6W	R
R106	0RD4702F608	RESISTOR,FIXED CARBON FILM	47K 1/6W	R
R107	0RD1002G608	RESISTOR,FIXED CARBON FILM	10K OHM 1/4 W	R
R20	0RD1001F608	RESISTOR,FIXED CARBON FILM	1.0K 1/6W	R
R21	0RD2202F608	RESISTOR,FIXED CARBON FILM	22K 1/6W	R
R22	0RD1001G608	RESISTOR,FIXED CARBON FILM	1K OHM 1/4 W	R
R25	0RD4701F608	RESISTOR,FIXED CARBON FILM	4.7K 1/6W	R
R26	0RD1001G608	RESISTOR,FIXED CARBON FILM	1K OHM 1/4 W	R
R28	0RD1002F608	RESISTOR,FIXED CARBON FILM	10K 1/6W	R
R29	0RD1001G608	RESISTOR,FIXED CARBON FILM	1K OHM 1/4 W	R
R34	0RD1002F608	RESISTOR,FIXED CARBON FILM	10K 1/6W	R
R35	0RD4701F608	RESISTOR,FIXED CARBON FILM	4.7K 1/6W	R
R50	0RD1001F608	RESISTOR,FIXED CARBON FILM	1.0K 1/6W	R
R51	0RD1000F608	RESISTOR,FIXED CARBON FILM	100 1/6W	R
R55	0RD1004F608	RESISTOR,FIXED CARBON FILM	1.0M 1/6W	R
R60	0RD4702G608	RESISTOR,FIXED CARBON FILM	47K 1/4W	R
R61	0RD1201G608	RESISTOR,FIXED CARBON FILM	1.2K 1/4W	R
R64	0RD4702G608	RESISTOR,FIXED CARBON FILM	47K 1/4W	R
R65	0RD1002F608	RESISTOR,FIXED CARBON FILM	10K 1/6W	R
R66	0RD1003F608	RESISTOR,FIXED CARBON FILM	100K 1/6W	R

R : SERVICE PARTS
* : ALTERNATE PARTS
N : NOT SERVICE PARTS

LOC. NO.	PART NO.	DESCRIPTION	SPECIFICATION	SVC
R69	0RD6600H608	RESISTOR, FIXED CARBON FILM	660 OHM 1/2 W	R
R70	0RD6600H608	RESISTOR, FIXED CARBON FILM	660 OHM 1/2 W	R
R73	0RD4004G608	RESISTOR, FIXED CARBON FILM	4MOHM 1/4 W	R
R74	0RD2004G608	RESISTOR, FIXED CARBON FILM	2MOHM 1/4 W	R
R75	0RD1004F608	RESISTOR, FIXED CARBON FILM	1.0M 1/6W	R
R76	0RD5103F608	RESISTOR, FIXED CARBON FILM	510K 1/6W	R
R77	0RD2703F608	RESISTOR, FIXED CARBON FILM	270K 1/6W	R
R78	0RD1503F608	RESISTOR, FIXED CARBON FILM	150K 1/6W	R
R80	0RD1202F608	RESISTOR, FIXED CARBON FILM	12K 1/6W	R
R81	0RD1202F608	RESISTOR, FIXED CARBON FILM	12K 1/6W	R
R82	0RD1202F608	RESISTOR, FIXED CARBON FILM	12K 1/6W	R
R83	0RD1202F608	RESISTOR, FIXED CARBON FILM	12K 1/6W	R
R84	0RD1202F608	RESISTOR, FIXED CARBON FILM	12K 1/6W	R
R85	0RD1202F608	RESISTOR, FIXED CARBON FILM	12K 1/6W	R
R86	0RD1202F608	RESISTOR, FIXED CARBON FILM	12K 1/6W	R
R90	0RD2202F608	RESISTOR, FIXED CARBON FILM	22K 1/6W	R
R91	0RD2202F608	RESISTOR, FIXED CARBON FILM	22K 1/6W	R
R92	0RD2202F608	RESISTOR, FIXED CARBON FILM	22K 1/6W	R
R93	0RD2202F608	RESISTOR, FIXED CARBON FILM	22K 1/6W	R
R94	0RD2202F608	RESISTOR, FIXED CARBON FILM	22K 1/6W	R
R95	0RD2202F608	RESISTOR, FIXED CARBON FILM	22K 1/6W	R
R62	0RN2003F408	RESISTOR, FIXED METAL FILM	200KOHM 1/6 W 1%	R
R63	0RN1001G408	RESISTOR, FIXED METAL FILM	1.0K 1/4W 1%	R
R67	0RN5101F408	RESISTOR, FIXED METAL FILM	5.10K 1/6W 1%	R
R68	0RN4901F408	RESISTOR, FIXED METAL FILM	4.9K OHM 1/6 W 1%	R
PT1	6010W2P008A	TRANSFORMER, POWER	120/60, UL, 12V/277MA	R
Q01	0TR101509AB	TRANSISTOR	A1015=KTA12660	R
Q02	0TR101509AB	TRANSISTOR	A1015=KTA12660	R
Q20	0TR106009AF	TRANSISTOR	KRC 106M	R
Q30	0TR181509AB	TRANSISTOR	KTC1815-Y=KTC3198Y	R
Q31	0TR107009AE	TRANSISTOR	KRA107M	R
Q50	0TR107009AD	TRANSISTOR	KRC 107M	R
VR1	CQ33026A	VARISTOR	INR14D271	R

R : SERVICE PARTS
* : ALTERNATE PARTS
N : NOT SERVICE PARTS

