

This Owner's Manual is provided and hosted by Appliance Factory Parts.

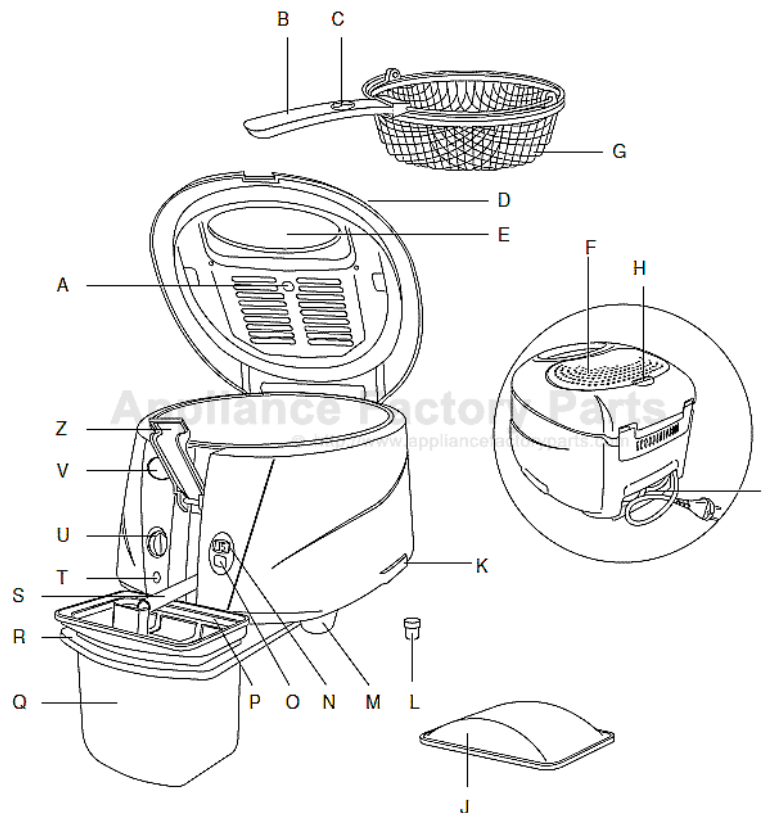

DE'LONGHI D895C Owner's Manual

[Shop genuine replacement parts for DE'LONGHI D895C](#)



[Find Your DE'LONGHI Deep Fryer Parts - Select From 56 Models](#)

----- Manual continues below -----

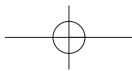

**ELECTRIC DEEP FRYER
FRITEUSE ELECTRIQUE
FREIDORA ELECTRICA
FRITADEIRA ELECTRICA**

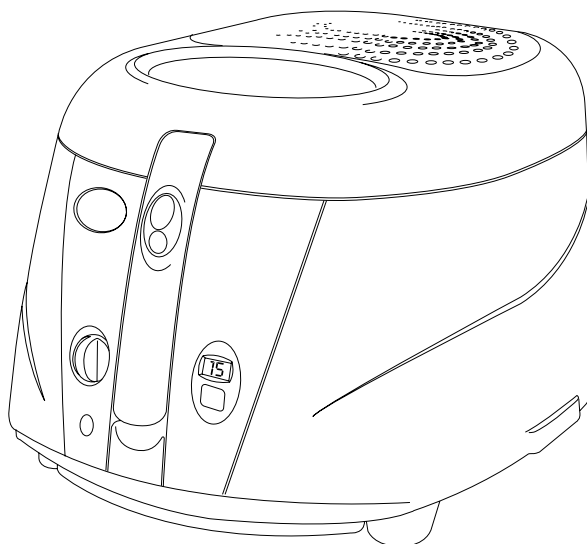

Instructions for use
Mode d'emploi
Instrucciones para el uso
Instruções

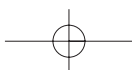

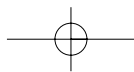
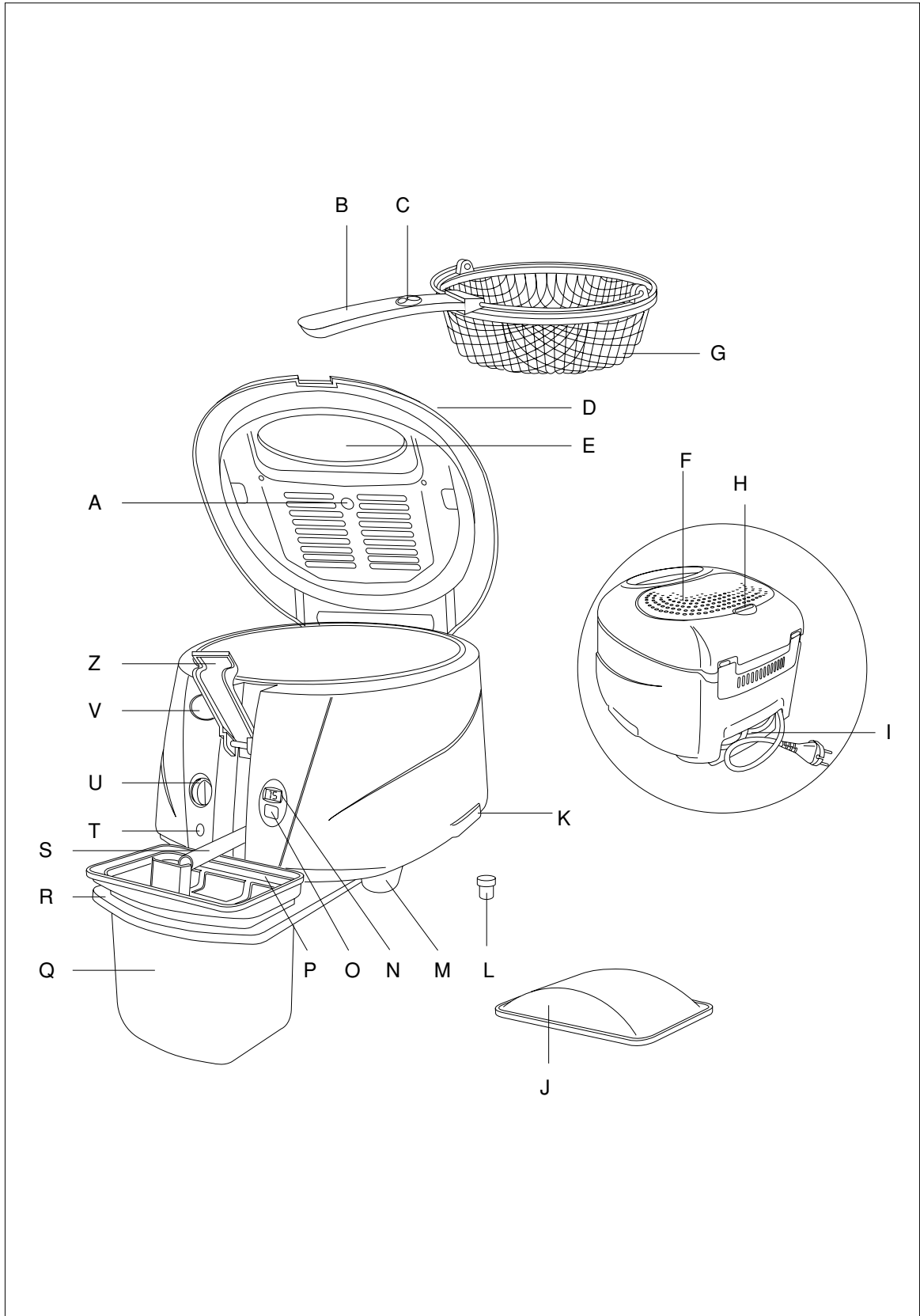
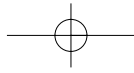

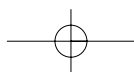
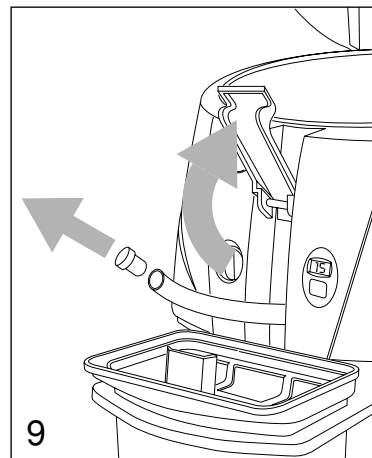
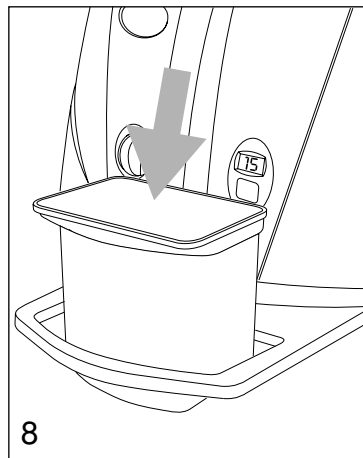
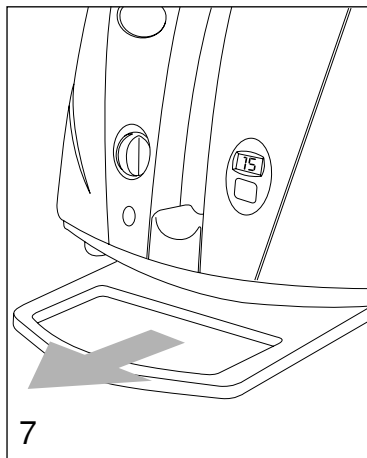
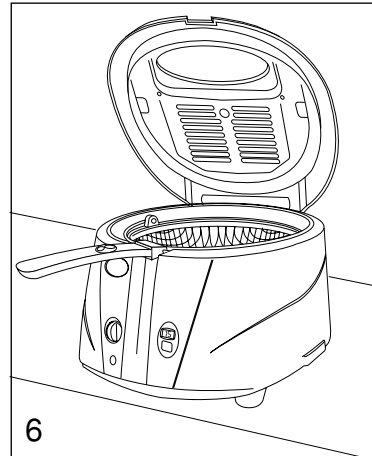
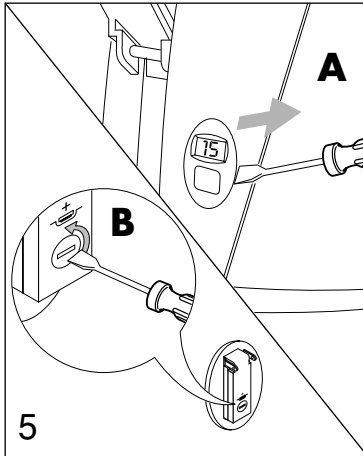
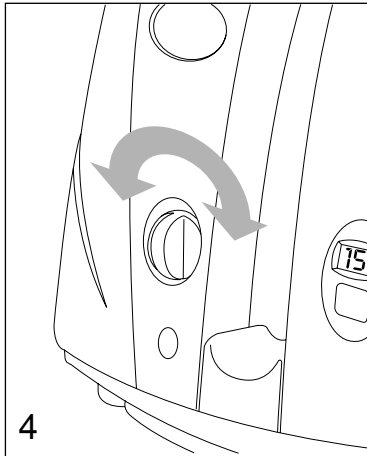
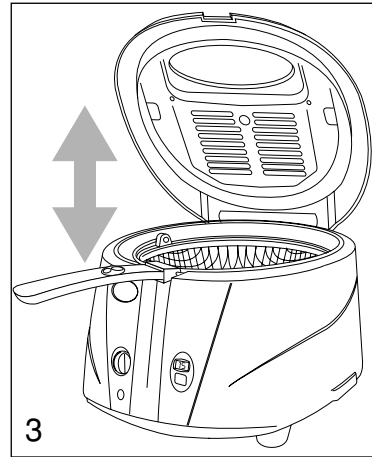
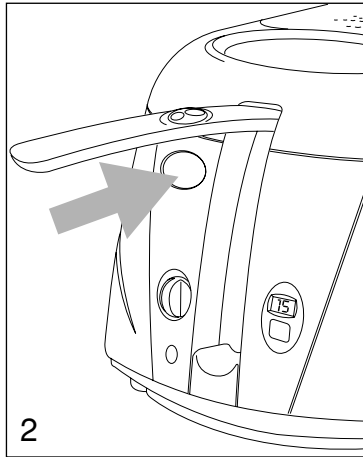
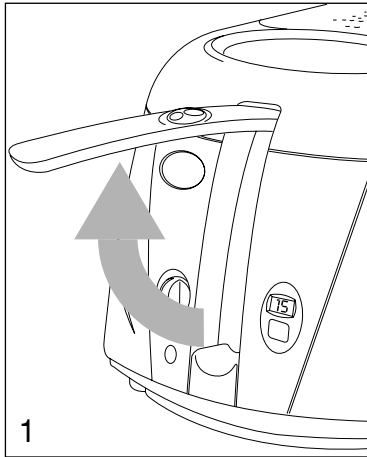
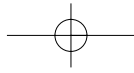

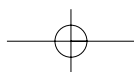
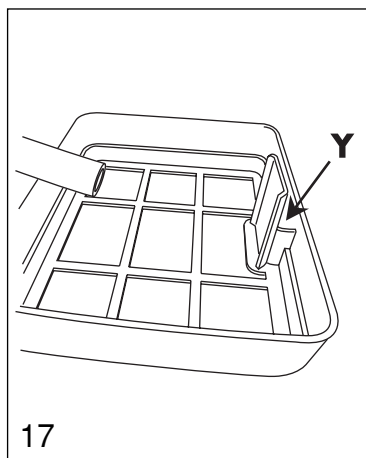
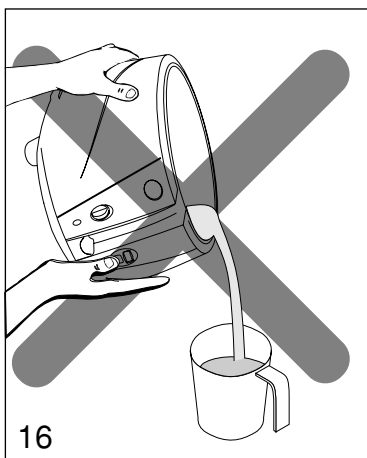
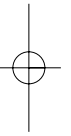
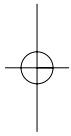
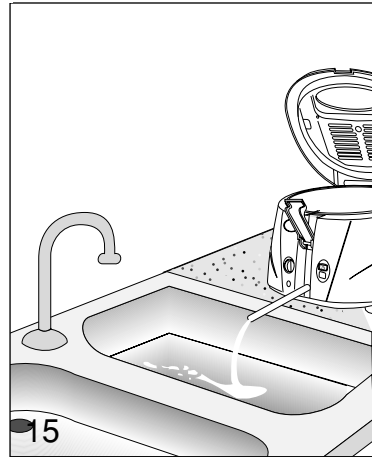
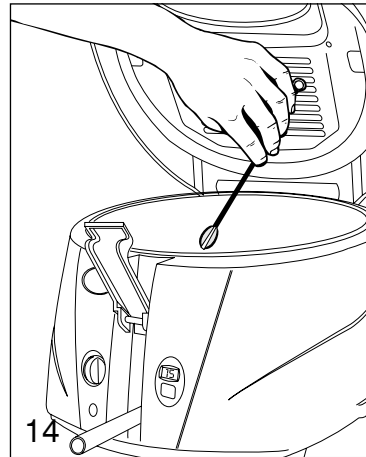
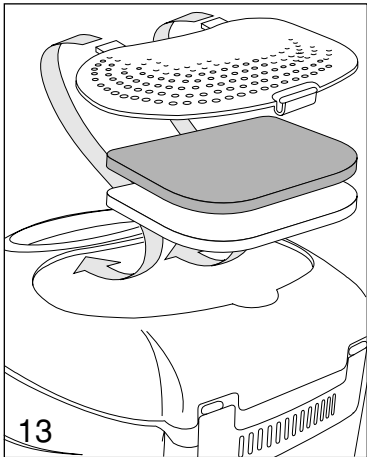
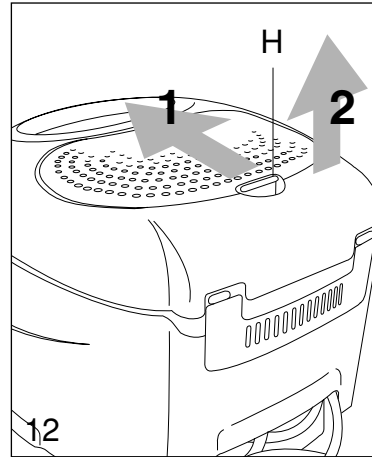
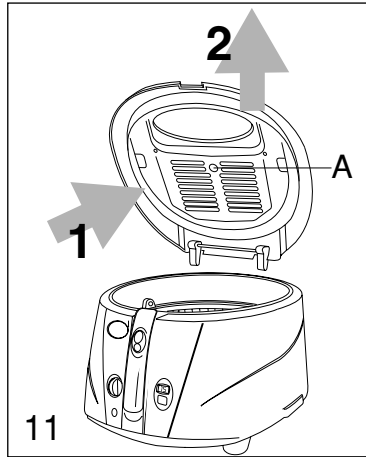
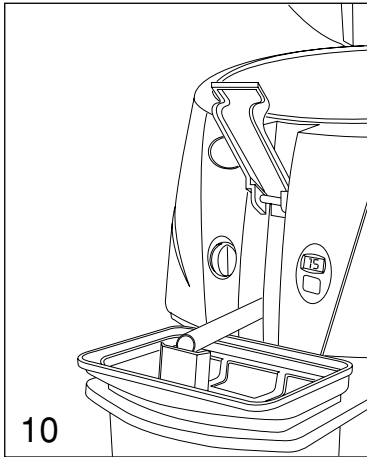
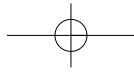

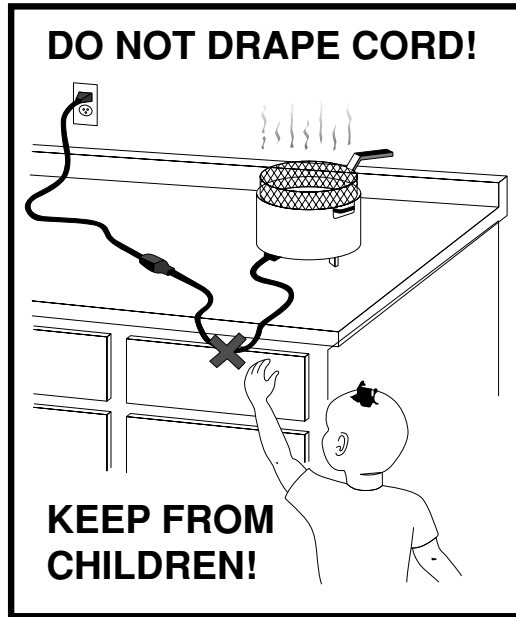

WARNING

SERIOUS HOT-OIL BURNS MAY RESULT FROM A DEEP FAT FRYER OR COOKER-FRYER BEING PULLED OFF OF A COUNTERTOP. DO NOT ALLOW THE CORD TO HANG OVER THE EDGE OF THE COUNTER WHERE IT MAY BE GRABBED BY CHILDREN OR BECOME ENTANGLED WITH THE USER. DO NOT USE WITH AN EXTENSION CORD.

IF YOUR DEEP FRYER IS SUPPLIED WITH A CORD SET WITH MAGNETIC CONNECTOR:

First fit the magnetic connector to the appliance, as seen in Figure 18, making sure that the protruding part of the connector "X" is correctly inserted in the corresponding slot on the appliance, and then plug the cable into the power outlet.

Warning

Never leave the appliance plugged into the power outlet if the magnetic connector is not fitted to the deep fryer, Figure 19.

If the magnetic connector does not remain in place, check that it has been inserted correctly, see Figure 18. If the problem persists, contact an authorised service centre.

When the appliance is powered, always leave some free space around the magnetic connector, so as to prevent it from becoming detached.

Only use a type TA-35PA cord set supplied by De'longhi authorised service centres.

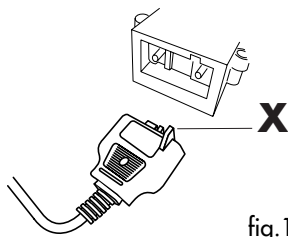

fig.18

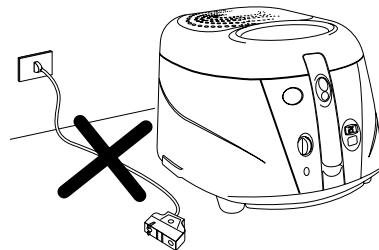

fig.19

IMPORTANT SAFEGUARDS

When using electrical appliances, basic safety precautions should always be followed, including the following:

1. Read all instructions.
2. Do not touch hot surfaces. Use handles and knobs.
3. To protect against electric shock do not immerse cord, plug and fryer in water or other liquid.
4. Close supervision is necessary when any appliance is used by or near children.
5. Unplug from outlet when not in use and before cleaning. Allow to cool before putting on or taking off parts, and before cleaning the appliance.
6. Do not operate any appliance with a damaged cord or plug or after the appliance malfunctions, or has been damaged in any manner. Return appliance to the nearest authorized service facility for examination, repair or adjustment.
7. The use of accessory attachments not recommended by the appliance manufacturer may cause injuries.
8. Do not use outdoors.
9. Do not let cord hang over edge of table or counter, or touch hot surfaces.
10. Do not place on or near a hot gas or electric burner or in a heated oven
11. Extreme caution must be used when moving an appliance containing hot oil or other liquids.
12. Always attach plug to appliance first, then plug cord into the wall outlet. To disconnect, turn the thermostat to the "OFF" position, then remove plug from wall outlet
13. Do not use appliance for other than intended use.
14. Be sure handle is properly assembled to basket and locked in place. See detailed assembly instructions.

SAVE THESE INSTRUCTIONS THIS PRODUCT IS FOR HOUSEHOLD USE ONLY

WARNING

- Plug cord into a 120 volt AC outlet.
- Only connect the appliance to electrical sockets which have a minimum load of 15A and which are properly earthed (*for appliances with a grounding plug*). (If the socket and the plug on the appliance should prove incompatible, get a professionally qualified technician to replace the socket with a more suitable one).
- If your product is provided with a polarized alternating current plug (a plug having one blade wider than the other), this plug will fit into the power outlet only one way. This is a safety feature. If you are unable to insert the plug fully into the outlet, try reversing the plug. If the plug should still fail to fit, contact your electrician to replace your obsolete outlet. Do not defeat the safety purpose of the polarized plug.
- Should the fryer leak, contact your nearest Service Center or authorized Dealer for qualified assistance.
- To assure safe operation, oversized foods or utensils must not be inserted into the fryer.
- Children or infirm persons should not be allowed to use this product unsupervised.
- Children should not be allowed to play with this appliance.
- It is totally normal that, on first use, the appliance emits a "new appliance" smell. If this happens, aerate the room.
- Before cleaning and when not in use, make sure that the power plug is disconnected.
- Do not move the deep fryer when the oil is hot, as it could cause serious burns.
- The deep fryer must only be switched on after it has been filled with oil or fat. If it is heated up while empty, a thermal safety device comes into operation which stops it from working. In this case it is necessary to contact our nearest authorised service centre.
- The basket clips automatically into the central pin in the bowl. Therefore, to avoid breaking it, do not turn it manually in order to seek the correct position.
- Wash the following carefully before using the deep fryer for the first time: the bowl, the basket, the lid (without filter) and the oil saving set (only on some models) with hot water and dish washing liquid. Dry carefully when this has been completed.
- The drainage pipe must always be closed and placed in its compartment while the appliance is in use.
- During use and when the oil is hot, the pipe compartment inspection door (only on some models) must always be closed.
- To move the appliance, use the special lifting handles. (Never lift by the basket handle).

DO NOT USE AN EXTENSION CORD

A short power supply cord is provided to reduce the risks resulting from being entangled in or tripping over a longer cord.

Read this instructions booklet carefully before installing and using the appliance. It is the only way to ensure the best results and maximum user safety.

DESCRIPTION OF THE APPLIANCE

(see diagram on the cover)

- A. Filter viewing window
- B. Basket handle
- C. Handle slide
- D. Lid
- E. Viewing window (not for all models)
- F. Filter cover
- G. Basket
- H. Filter cover latch
- I. Cord storage compartment
- J. Oil container lid
- K. Hand grips for lifting up the appliance
- L. Drainage pipe plug
- M. Foot
- N. Minute timer (not for all models)
- O. Minute timer button (not for all models)
- P. Oil filter
- Q. Oil container
- R. Box for oil container
- S. Oil drainage pipe
- T. Signal lamp
- U. Thermostat and on/off knob
- V. Opening button
- Z. Door for oil drainage pipe

INSTRUCTIONS FOR USE

FILLING WITH OIL OR FAT

- Raise the basket to the highest position by pulling the special "B" handle upwards (fig.1).
The lid should ALWAYS be closed when the basket is raised and lowered.
- Open lid "D" by pressing button "V" (fig.2).
- Remove the basket by pulling it upwards (fig.3).
- Pour into the container 1.2 litres of oil (or 1 kg. of fat).

WARNING

The level must always be between the maximum and minimum levels indicated.

Never use the deep fryer when the oil is below the "min" level as it could cause the thermal safety device to come into operation; to replace it you need to contact one of our service centres.

Best results are obtained by using a good peanut oil. Avoid mixing different types of oil. If you use lumps of solid fat, cut them into small pieces so that the deep fryer does not heat up in the first few minutes without a covering of fat. The temperature must be set to 150°C until the fat has melted completely. The required temperature can then be set.

STARTING TO FRY

1. Put the food which is to be fried into the basket, without ever overfilling it (max. 2,2 lb. of fresh potatoes).
In order to obtain a more even frying, we recommend concentrating the food especially around the perimeter of the basket., leaving the central part more sparingly filled.
2. Put the basket into the bowl in a raised position (fig.3) and close the lid by pressing lightly down upon it until the latches click.
3. Set thermostat knob "U" to the required temperature (fig.4). When the temperature set has been reached, signal lamp "T" will go off.
4. As soon as the signal lamp goes off, immerse the basket in the oil, lowering the handle slowly after sliding the handle's "C" slider back.
 - It is completely normal for a considerable amount of very hot steam to pour out of filter cover "F" immediately after this.
 - At the start of cooking, immediately after the food has been immersed in the oil, the internal wall of viewing window "E" (where present) will steam up, before progressively clearing.
 - It is normal for drops of condensation to form around the basket handle while the appliance is working.

In the models fitted with the electronic minute timer

1. Set the cooking time by pressing key "O"; display "N" will show the minutes set.
2. The figures will begin flashing immediately afterwards, signifying that the cooking time has started. The last minute will be visualised in seconds.
3. In the event of error, the new cooking time can be set by keeping the button pressed down for more than 2 seconds. The display will reset itself, then repeat as for point 1 (above).
4. The minute timer will show the end of the cooking time with two series of beeps at an interval of about 20 seconds. In order to switch off the audible alarm you only need press minute timer key "O".

WARNING: the minute timer does not switch the appliance off.

Replacing the minute timer battery (fig.5)

- Remove the minute timer from its compartment by prying it from the right side (see fig.5A).
- Turn the battery cover (fig.5B) placed on the back in an anticlockwise direction until it is released.
- Replace the battery with another of the same type.

AFTER FRYING

When the cooking time runs out raise the basket and check if the food has reached the required golden colour. In the models fitted with a viewing window this check can be carried out by looking through the window without opening the lid.

If you consider the cooking to be finished, switch off the appliance by turning the thermostat knob to the OFF position until you hear the click of the internal switch.

Allow the excess oil to drip off by leaving the basket in the deep fryer in the high position.

P.S. If the cooking needs to be done in two phases (e.g. potatoes) raise the basket at the end of the first phase and wait for the signal lamp to go off again. Then immerse the basket back in the oil for a second time (see enclosed tables).

FILTERING THE OIL OR FAT

We recommend that you carry out this procedure each time you have finished frying as, especially when the food has been breaded or floured, the food particles tend to burn if they remain in the liquid thus causing much quicker deterioration in the oil or fat.

Check that the oil is cool enough, waiting about 2 hours.

Bring the front part of the deep fryer to the edge of the work surface, being careful that feet "M" are always inside the area of the work surface (fig. 6).

1. Pull tray "R" outwards (as in fig.7)
2. Place oil container "Q" without the "J" lid in the special compartment (fig.8).
3. Remove the basket.
4. Open inspection door "Z" (as in fig.9).
5. Insert oil filter "P" onto the container (fig.9)
6. Extract drainage pipe "S", remove plug "L" while at the same time squeezing the pipe between two fingers to avoid the liquid coming out until it has been positioned above the filter (see fig. 10).
7. Flow the oil into the oil container "Q". Pinch the oil drainage pipe "S" between two fingers to regulate the flow and avoid the oil leaking out of the openings "Y" (fig. 17). These openings are provided to prevent the oil overflowing from the filter tray if it drains too fast or the filter is clogged. In this case, filtering will not be optimum. If the oil is particularly "dirty", be careful to ensure that it does not overflow from the filter.
8. Reposition the pipe in its compartment after replacing the plug and close the inspection door.
9. Put down the container, stopping it with lid "J" in

order to ensure better preservation of the oil for future use.

10. Reposition the tray as at the beginning.

* ***In the event of fat being used, be careful not to let it cool down too much or it will solidify.***

REPLACING THE ODOUR-EATER FILTER

With time the odour-eater filters placed inside the lid lose their effectiveness. A change of colour in the filter, visible through hole "A" of fig.11 on the inside cover, shows that the filter needs to be changed. To replace it, remove plastic filter cover "F" (fig.12) by pressing latch "H" in the direction of arrow 1, then raise it in the direction of arrow 2. Replace the filters.

P.S. The white filter must rest on the metal part (fig.13) and the coloured area must face upwards (or towards the black filter).

Reassemble the filter cover, being careful to insert the front latches correctly (as shown in fig.13).

Do not run the appliance with exhausted filters as this could obstruct the steam causing bad odours.

CLEANING

Before cleaning, always remove the plug from the electrical socket.

* ***Never immerse the deep fryer in water or hold it under the tap. By getting inside the water would cause short circuiting.***

After having appropriately allowed the oil to cool for about 2 hours, empty out the oil or fat as previously described in the paragraph headed "filtering the oil or fat".

Remove the lid as shown in fig. 11.

Do not immerse the lid in water without having first removed the filters.

To clean the bowl, proceed as follows:

- Wash the tank with hot water and washing up liquid. Always use the oil drainage pipe to empty out the water as shown in fig. 15. Then rinse and dry carefully; remove any remaining water which has collected in the oil drainage pipe.
- * ***Never empty the deep fryer by tilting it or turning it upside down (fig.16)***
- In order to clean the inside of the drainage pipe, use the pipe brush supplied (fig. 14).
- We advise regular cleaning of the basket, with care being taken to eliminate any deposits which might have accumulated in the basket's wheel guide ring.
- Dry the outside of the deep fryer with a soft, damp cloth in order to get rid of splashes and any little dribbles of oil or condensation.
- Clean and dry the washer as well in order to avoid it sticking to the bowl when the boiler is not in use. (To open the lid in the event of sticking, you only need to raise the lid by hand while at the same time keeping

- the opening button pressed down).
- Remove the lid by pushing it gently backwards (see arrow "1" fig. 11) and pulling upwards (see arrow "2" fig. 11).
 - After washing, dry thoroughly. Remove any water left in the bottom of the container and, in particular, inside the oil drainage pipe. This avoids dangerous spurts of hot oil during use.

Model with non-stick bowl

To clean the bowl use a soft cloth with a neutral detergent never using objects or abrasive detergents.

COOKING HINTS

HOW LONG THE OIL OR FAT LASTS

The oil or fat must never go below the minimum level.

From time to time it is necessary to renew it completely. The length of time the oil or fat lasts depends on what is fried.

Breading, for example, dirties the oil more than simple frying.

As for all types of deep fryer, the oil deteriorates if it is reheated several times! Therefore, even if it is used and filtered correctly, we recommend replacing it completely fairly often.

Since the deep fryer works with little oil, due to its rotating basket, there is the considerable advantage that you only have to get rid of about half the amount of oil that you would with the other deep fryers on the market.

HOW TO FRY CORRECTLY

- It is important to follow the recommended temperature for every recipe. If the temperature is too low, the fried food absorbs oil. If the temperature is too high a crust quickly forms on the outside while the inside remains uncooked.
- **The food which is to be fried must only be immersed when the oil has reached the right temperature, i.e. when the signal lamp goes off.**
- Do not overfill the basket. This would cause the temperature of the oil to drop suddenly, resulting in fried food which is too greasy and not uniformly fried.
- When frying small quantities of food, the temperature of the oil must be set lower than the temperature indicated to avoid the oil boiling too violently.
- Check that the food is thinly sliced and of even thickness, as food which is too thick cooks badly on

the inside, despite looking nice, while food of an even thickness reaches the ideal cooking point all at the same time.

- **Dry the food completely before immersing it in the oil or fat**, as wet food becomes soggy after cooking (especially potatoes). It is advisable to bread or flour food which has a high water content (fish, meat, vegetables), being careful to remove the excess bread or flour before immersing it in the oil.

TEMPERATURE AND COOKING TIMES

Remember that the cooking temperatures and times are approximate, and will vary according to the quantity of food being fried and to individual tastes.

Food	Max. quantity		Temperature		Time (minutes)
	gr	lb	°C	°F	
FRIED POTATOES half portion	500	1	190	370	1 st phase 6 - 7 2 nd phase 1 - 2
whole portion	1000	2	190	370	1 st phase 10 - 12 2 nd phase 2 - 2,5
APPETIZER AND SNACKS					
Crispy Shrimp Balls	750	1.5	160	320	7 - 8
Zesty Meatballs	500	1	170	340	6 - 7
Chicken and Vegetable Egg Rolls	250	0.5	170	340	4 - 5
Fried wontons	250	0.5	170	340	3 - 4
MAIN DISHES					
Crispy Fried Chicken Pieces	500-750	1-1.5	170	340	20 - 25
Sweet and Sour Chicken Balls	500	1	170	340	3 - 4
Clams, Oysters, Scallops, Shrimps	750-1kg	1.5 - 2	160	320	5 - 6
Veal Parmesan	500	1	170	340	6 - 7
Batter-Fried Fish	500	1	160	320	9 - 10
Crispy Fish Fillets	500	1	160	320	8 - 9
Chicken Fingers	500	1	170	340	3
Sesame-Nut Chicken	250	0.5	170	340	5 - 6
VEGETABLES AND SIDE DISHES					
Potato Puffs	500	1	190	370	3 - 5
Fried Potato Wedges	500	1	190	370	Phase 1 10 - 12 Phase 2 3
Vegetable Fritters Parmesan	250	0.5	150	300	3 - 5
Crispy Onion Rings	500	1	150	300	3 - 5
DESSERTS					
Yeast Doughnuts	500	1	190	370	4 - 5
Fruit Fritters	500	1	190	370	4 - 6

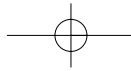

FRYING FROZEN FOODS

- Due to their extremely low temperature, frozen foods inevitably lower the temperature of the oil. For best results, do not overload the basket with frozen foods.
- Follow the instructions on the frozen food package for cooking times and temperature.
- **Frozen foods are frequently covered with a coating of ice crystals, which should be removed before frying.** Lower the basket very slowly into the oil in order to ensure that the oil does not boil over.

TROUBLESHOOTING

FAULT	CAUSE	REMEDY
Bad smell	The odour-eater filter is saturated. The oil has deteriorated. The cooking liquid is unsuitable.	Replace the filter. Replace the oil or fat. Use a good peanut oil.
The oil overflows	The oil has deteriorated and causes too much foam. You have immersed food which is not sufficiently dry in the hot oil. The basket has been immersed too quickly. The oil level in the deep fryer is over the maximum limit.	Replace the oil or fat. Dry the food well. Immerse it slowly. Reduce the amount of oil in the bowl.
The oil does not heat up	The deep fryer has previously been used without oil in the bowl, causing the thermal safety device to break. The magnetic convector is not correctly inserted	Contact the Service Centre (the device must be replaced). Insert the connector with the jut "X" on the top side Contact the Service Centre
Only half of the basket has fried properly.	The basket does not rotate during cooking.	Clean the bottom of the bowl. Clean the basket wheel guide ring.

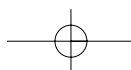

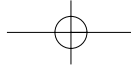

De'Longhi

Limited Warranty

What Does This Warranty Cover? We warrant each appliance to be free from defects in material and workmanship. Our obligation under this warranty is limited to replacement or repair, free of charge at our factory or authorized service centers, of any defective part or parts thereof other than parts damaged in transit, which shall be returned to us, transportation prepaid. This warranty shall apply only if the appliance is used in accordance with the factory directions which accompany it, and on an Alternating Current (AC) circuit.

How Long Does The Coverage Last? This warranty runs for one year from the date of delivery and applies only to the original purchaser.

What Does This Warranty Not Cover? This warranty does not cover defects or damage of the appliance which result from repairs or alterations to the machine outside our factory or authorized service centers, nor shall it apply to any appliance which has been subject to abuse, misuse, negligence or accidents. Also, consequential and incidental damages resulting from the use of this product or arising out of any breach of contract or breach of this warranty are not recoverable under this warranty. Some states do not allow the exclusion or limitation of incidental or consequential damages, so the above limitation may not apply to you.

How Do You Get Service? If repairs become necessary or spare parts are needed, please write to:

De'Longhi America Inc.
Park 80 West Plaza One, 4th floor
Saddle Brook N.J. 07663
or call Service Tel. No. 001-201-909-4000

De' Longhi CANADA
1040 Ronsa Court
MISSISSAUGA, ONTARIO
L4W 3Y4 CANADA

The above warranty is in lieu of all other express warranties and representations; All implied warranties are limited to the applicable warranty period set forth above. This limitation does apply if you enter into an extended warranty with De'Longhi. Some states do not allow limitations on how long an implied warranty lasts, so the above exclusions connection with the sale or use of its appliance.

How Does State Law Apply? This warranty gives you specific legal rights, and you may also have other rights which vary from state to state.

