

This Owner's Manual is provided and hosted by [Appliance Factory Parts](http://www.ApplianceFactoryParts.com).



# FRIEDRICH MR18C3E-A Owner's Manual

[Shop genuine replacement parts for FRIEDRICH  
MR18C3E-A](#)



[Find Your FRIEDRICH Air Conditioner Parts - Select From 1575 Models](#)

----- Manual continues below -----



**SPLIT TYPE  
ROOM AIR CONDITIONER  
WALL MOUNTED type**

# SERVICE MANUAL

## Reciprocating Compressor Models

Indoor unit	Outdoor unit
MW18C3E	MR18C3E
MW18Y3E	MR18Y3E
MW24C3E	MR24C3E
MW24Y3E	MR24Y3E
MW30C3E	MR30C3E

---

---

## Rotary Compressor Models

Indoor unit	Outdoor unit
MW18C3E	MR18C3E-A
MW18Y3E	MR18Y3E-A
MW24C3E	MR24C3E-A
MW24Y3E	MR24Y3E-A

## CONTENTS

SPECIFICATIONS	1
OUTLINE AND DIMENSIONS	3
REFRIGERANT SYSTEM DIAGRAM	4
CIRCUIT DIAGRAM	9
INDOOR PRINTED CIRCUIT BOARD CIRCUIT DIAGRAM	14
ERROR DISPLAY	17
DISASSEMBLY ILLUSTRATION	18
PARTS LIST	35

# SPECIFICATIONS RECIPROCATING COMPRESSOR MODELS

TYPE		COOL	COOL & HEAT	COOL	COOL & HEAT	COOL
INDOOR UNIT		MW18C3E	MW18Y3E	MW24C3E	MW24Y3E	MW30C3E
OUTDOOR UNIT		MR18C3E	MR18Y3E	MR24C3E	M224Y3E	MR30C3E
COOLING CAPACITY	(BTU / h)	18,000 - 17,000	17,500 - 16,500	23,000 - 22,500	23,000 - 22,500	29,500 - 28,700
HEATING CAPACITY	(BTU / h)	-----	18,000 - 17500	-----	23,500 - 22,500	-----

## ELECTRICAL DATA

POWER SOURCE		(V)				
POWER SOURCE		230 / 208				
FREQUENCY		(Hz)				
FREQUENCY		60				
RUNNING CURRENT (A)	COOLING	7.6 - 8.2	7.8 - 8.5	10.0 - 10.8	9.9 - 10.7	15.0 - 16.0
	HEATING	-----	7.2 - 7.5	-----	8.9 - 9.7	-----
INPUT WATTS (kW)	COOLING	1.70 - 1.65	1.75 - 1.71	2.20 - 2.15	2.23 - 2.19	3.15 - 3.05
	HEATING	-----	1.58 - 1.53	-----	2.02 - 1.98	-----
E.E.R. (BTU / h.W)	COOLING	10.6 - 10.3	10.0 - 9.65	10.5 - 10.5	10.3 - 10.3	9.37 - 9.41
	HEATING	-----	11.3 - 11.4	-----	11.6 - 11.4	-----
MOISTURE REMOVAL	( / hr)	2.0	1.8	2.7	2.7	4.3
AIR CIRCULATION - Hi	( <sup>3</sup> / m / hr)	800	800	1,100	1,100	1,100

## COMPRESSOR

TYPE	Hermetic type, Permanent split condenser, 2 poles, Single phase, Induction motor, Recipro				
CODE	H25B18QABCA	H25B18QABCA	H25B24QABCA	H25B24QABCA	H25B35QABCA
REFRIGERANT R-22 (g)	1,700	2,250	2,200	2,350	1,900

## FAN MOTOR

POWER SOURCE		(V)				
POWER SOURCE		230 / 208				
INDOOR UNIT	TYPE (r.p.m.)	MFA-18FPH	MFA-18FPH	MFA-30FPH	MFA-30FPH	MFA-18FPH
	HI-SPEED (r.p.m.)	960 - 870	960 - 870	1,260 - 1,160	1,260 - 1,160	1,260 - 1,160
	MED-SPEED (r.p.m.)	840 - 750	840 - 750	1,130 - 1,030	1,130 - 1,030	1,130 - 1,030
	LO-SPEED (r.p.m.)	720 - 580	720 - 580	990 - 870	990 - 870	990 - 870
OUTDOOR UNIT	TYPE (r.p.m.)	MFB-24FP	MFB-24FP	MFB-24FP	MFB-24FP	MFB-30BP
	(r.p.m.)	735	735	735	735	790

## DIMENSIONS

INDOOR UNIT	HEIGHT	inch (mm)	12 - 19/32" (320)	12 - 19/32" (320)	12 - 19/32" (320)	12 - 19/32" (320)	12 - 19/32" (320)
	WIDTH	inch (mm)	49 - 7/32" (1,250)	49 - 7/32" (1,250)	49 - 7/32" (1,250)	49 - 7/32" (1,250)	49 - 7/32" (1,250)
	DEPTH	inch (mm)	7 - 11/16" (195)	7 - 11/16" (195)	7 - 11/16" (195)	7 - 11/16" (195)	7 - 11/16" (195)
OUTDOOR UNIT	HEIGHT	inch (mm)	25 - 1/8" (643)	25 - 1/8" (643)	25 - 1/8" (643)	25 - 1/8" (643)	45 - 11/32" (1,152)
	WIDTH	inch (mm)	33 - 1/32" (840)	33 - 1/32" (840)	33 - 1/32" (840)	33 - 1/32" (840)	37 - 1/32" (940)
	DEPTH	inch (mm)	13 - 1/4" (336)	13 - 1/4" (336)	13 - 1/4" (336)	13 - 1/4" (336)	14 - 9/16" (370)

## WEIGHTS

INDOOR UNIT	GROSS / NET lbs (kg)	55 / 40 (25 / 18)	55 / 40 (25 / 18)	55 / 40 (25 / 18)	55 / 40 (25 / 18)	55 / 40 (25 / 18)
OUTDOOR UNIT	GROSS / NET lbs (kg)	163 / 145 (74 / 66)	165 / 147 (75 / 67)	165 / 147 (75 / 67)	167 / 150 (76 / 68)	238 / 207 (108 / 94)

## REFRIGERANT CHARGING

PIPE LENGTH		25 ft. (7.5 m)	33 ft. (10 m)	49 ft. (15 m)	66 ft. (20 m)	83 ft. (25 m)	98 ft. (30 m)
FULL CHARGE AMOUNT	MR18C3E	1,700 g (60.0 oz.)	1,730 g (61.1 oz.)	1,790 g (63.2 oz.)	1,850 g (65.3 oz.)	-----	-----
	MR18Y3E	2,250 g (79.4 oz.)	2,335 g (82.4 oz.)	2,505 g (88.4 oz.)	2,675 g (94.4 oz.)	-----	-----
	MR24C3E	2,200 g (77.6 oz.)	2,230 g (78.7 oz.)	2,290 g (80.8 oz.)	2,350 g (82.9 oz.)	-----	-----
	MR24Y3E	2,350 g (82.9 oz.)	2,435 g (85.9 oz.)	2,605 g (91.9 oz.)	2,775 g (97.9 oz.)	-----	-----
	MR30C3E	1,900 g (67.0 oz.)	1,943 g (68.5 oz.)	2,028 g (71.5 oz.)	2,113 g (74.5 oz.)	2,198 g (77.5 oz.)	2,283 g (80.5 oz.)

Note : Whenever 7.5 m is exceeded, and/or when using a line set length other than those found in the table, charge with additional refrigerant as follows: 34 g (1.20 oz.) / 3.3 ft. (1 m) for 18Y, 24Y Models, 14.4 g (0.51 oz.) / 3.3 ft (1 m) for 18C Model, 12 g (0.42 oz.) / 3.3 ft (1 m) for 24C Model, and 17 g (0.60 oz.) / 3.3 ft (1 m) for 30C Model.

# S P E C I F I C A T I O N S

## R O T A R Y C O M P R E S S O R M O D E L S

TYPE	COOL	COOL & HEAT	COOL	COOL & HEAT
INDOOR UNIT	MW18C3E	MW18Y3E	MW24C3E	MW24Y3E
OUTDOOR UNIT	MR18C3E-A	MR18Y3E-A	MR24C3E-A	MR24Y3E-A
COOLING CAPACITY (BTU / h)	18,000 - 17,000	17,500 - 16,500	23,000 - 22,500	23,000 - 22,500
HEATING CAPACITY (BTU / h)	-----	18,000 - 17500	-----	23,500 - 22,500

### ELECTRICAL DATA

POWER SOURCE (V)		230 / 208			
FREQUENCY (Hz)		60			
RUNNING CURRENT (A)	COOLING	8.3 - 9.1	8.2 - 8.9	10.7 - 11.7	10.5 - 11.3
	HEATING	-----	8.0 - 8.5	-----	9.9 - 10.4
INPUT WATTS (kW)	COOLING	1.91 - 1.87	1.89 - 1.84	2.41 - 2.40	2.34 - 2.29
	HEATING	-----	1.82 - 1.77	-----	2.18 - 2.13
E.E.R. (BTU / h.W)	COOLING	9.4 - 9.0	9.26 - 8.97	10.7 - 11.7	9.82 - 9.83
	HEATING	-----	9.89 - 9.89	-----	10.8 - 10.6
MOISTURE REMOVAL (/ hr)		2.0	1.8	2.7	2.7
AIR CIRCULATION - Hi (m <sup>3</sup> / hr)		800	800	1,000	1,000

### COMPRESSOR

TYPE	Hermetic type, Permanent split condenser, 2 poles, Single phase, Induction motor			
CODE	PH28NSGT	PH28NSGT	PH33NTJT	PH33NTJT
REFRIGERANT R-22 (g)	1,700	1,900	2,000	2,200

### FAN MOTOR

POWER SOURCE (V)		230 / 208			
INDOOR UNIT	TYPE (r.p.m.)	MFA-18FPHT	MFA-18FPHT	MFA-30FPHT	MFA-30FPHT
	HI-SPEED (r.p.m.)	960 - 870	960 - 870	1,260 - 1,160	1,260 - 1,160
	MED-SPEED (r.p.m.)	840 - 750	840 - 750	1,130 - 1,030	1,130 - 1,030
	LO-SPEED (r.p.m.)	720 - 580	720 - 580	990 - 870	990 - 870
OUTDOOR UNIT	TYPE	MFB-24FP	MFB-24FP	MFB-24FP	MFB-24FP
	(r.p.m.)	735	735	735	735

### DIMENSIONS

INDOOR UNIT	HEIGHT inch (mm)	12 - 19/32" (320)	12 - 19/32" (320)	12 - 19/32" (320)	12 - 19/32" (320)
	WIDTH inch (mm)	49 - 7/32" (1,250)	49 - 7/32" (1,250)	49 - 7/32" (1,250)	49 - 7/32" (1,250)
	DEPTH inch (mm)	7 - 11/16" (195)	7 - 11/16" (195)	7 - 11/16" (195)	7 - 11/16" (195)
OUTDOOR UNIT	HEIGHT inch (mm)	25 - 1/8" (643)	25 - 1/8" (643)	25 - 1/8" (643)	25 - 1/8" (643)
	WIDTH inch (mm)	33 - 1/32" (840)	33 - 1/32" (840)	33 - 1/32" (840)	33 - 1/32" (840)
	DEPTH inch (mm)	13 - 1/4" (336)	13 - 1/4" (336)	13 - 1/4" (336)	13 - 1/4" (336)

### WEIGHTS

INDOOR UNIT	GROSS / NET lbs (kg)	55 / 40 (25 / 18)	55 / 40 (25 / 18)	55 / 40 (25 / 18)	55 / 40 (25 / 18)
OUTDOOR UNIT		163 / 145 (74 / 66)	165 / 147 (75 / 67)	165 / 147 (75 / 67)	167 / 150 (76 / 68)

### REFRIGERANT CHARGING

PIPE LENGTH		25 ft. (7.5 m)	33 ft. (10 m)	49 ft. (15 m)	66 ft. (20 m)
FULL CHARGE AMOUNT	MR18C3E-A	1,700 g (60.0 oz.)	1,736 g (61.2 oz.)	1,808 g (63.7 oz.)	1,880 g (66.3 oz.)
	MR18Y3E-A	1,900 g (67.0 oz.)	1,985 g (70.0 oz.)	2,155 g (76.0 oz.)	2,325 g (82.0 oz.)
	MR24C3E-A	2,000 g (67.0 oz.)	2,030 g (71.6 oz.)	2,060 g (72.7 oz.)	2,120 g (74.8 oz.)
	MR24Y3E-A	2,200 g (77.6 oz.)	2,285 g (80.6 oz.)	2,455 g (86.6 oz.)	2,625 g (92.6 oz.)

Note : Whenever 7.5 m is exceeded, and/or when using a line set length other than those found in the table, charge with additional refrigerant as follows:  
 34 g (1.20 oz.) / 3.3 ft. (1 m) for 18Y, 24Y Models and 14.4 g (0.51 oz.) / 3.3 ft (1 m) for 18C Model and 12 g (0.42 oz.) / 3.3 ft (1 m) for 24C Model.

# OUTLINE AND DIMENSIONS

Models: MW18C3E, MW18Y3E  
 MW24C3E, MW24Y3E  
 MW30C3E

Unit : inch (mm)

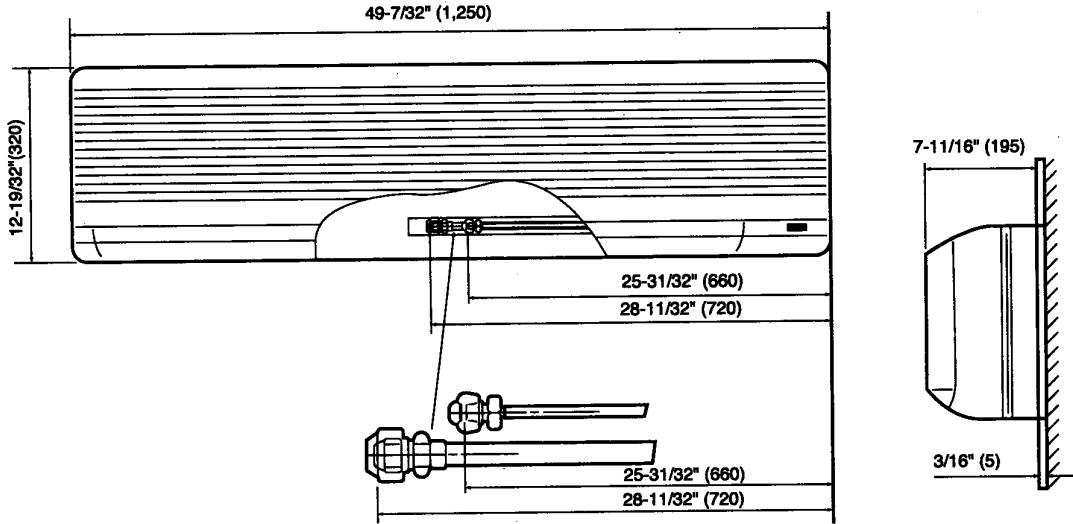

Models: MR18C3E, MR18C3E-A  
 MR18Y3E, MR18Y3E-A  
 MR24C3E, MR24C3E-A  
 MR24Y3E, MR24Y3E-A

Model: MR30C3E

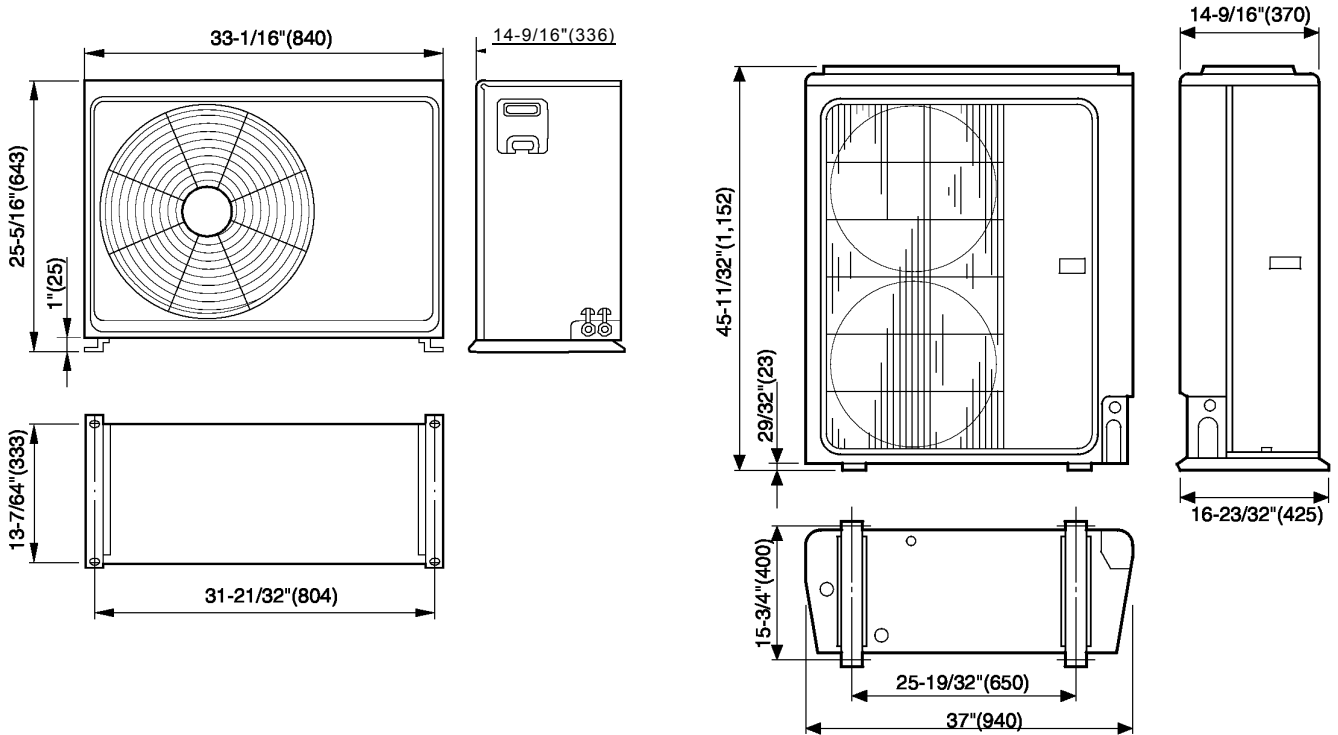



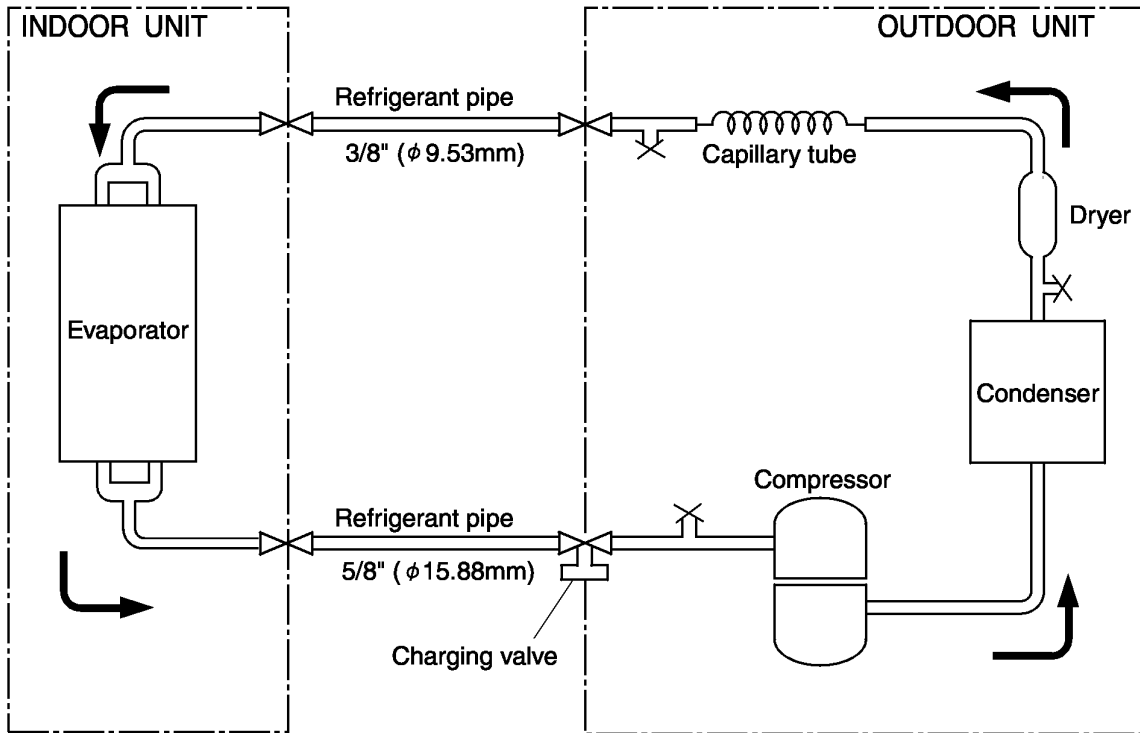

# REFRIGERANT SYSTEM DIAGRAM

Models: MW18C3E / MR18C3E

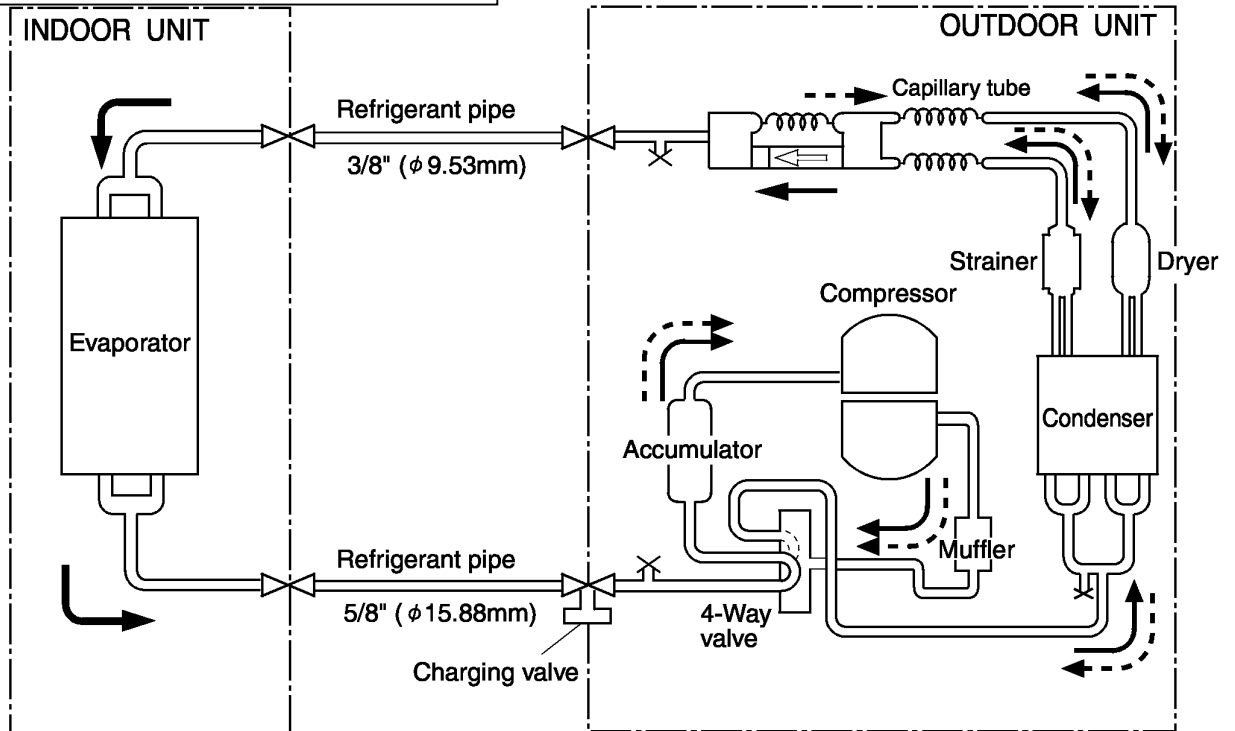

Models: MW18Y3E / MR18Y3E



 Cooling  
 Heating  
 : Flare coupling

Models: MW24C3E / MR24C3E

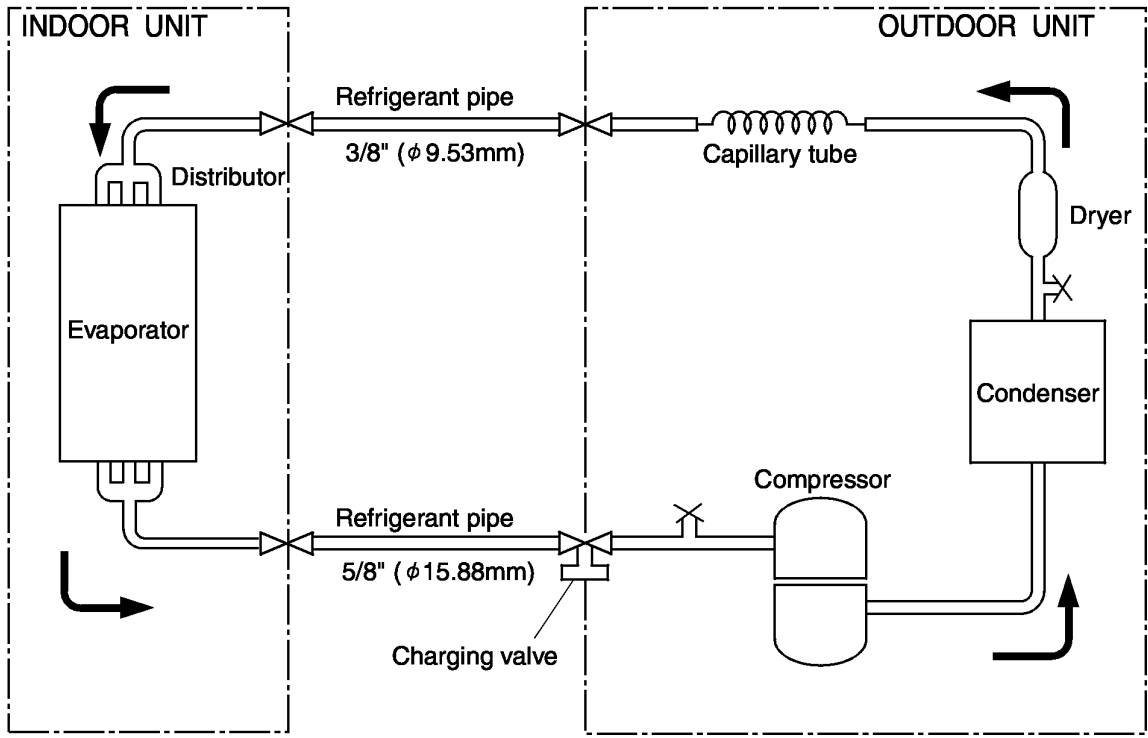

Models: MW24Y3E / MR24Y3E

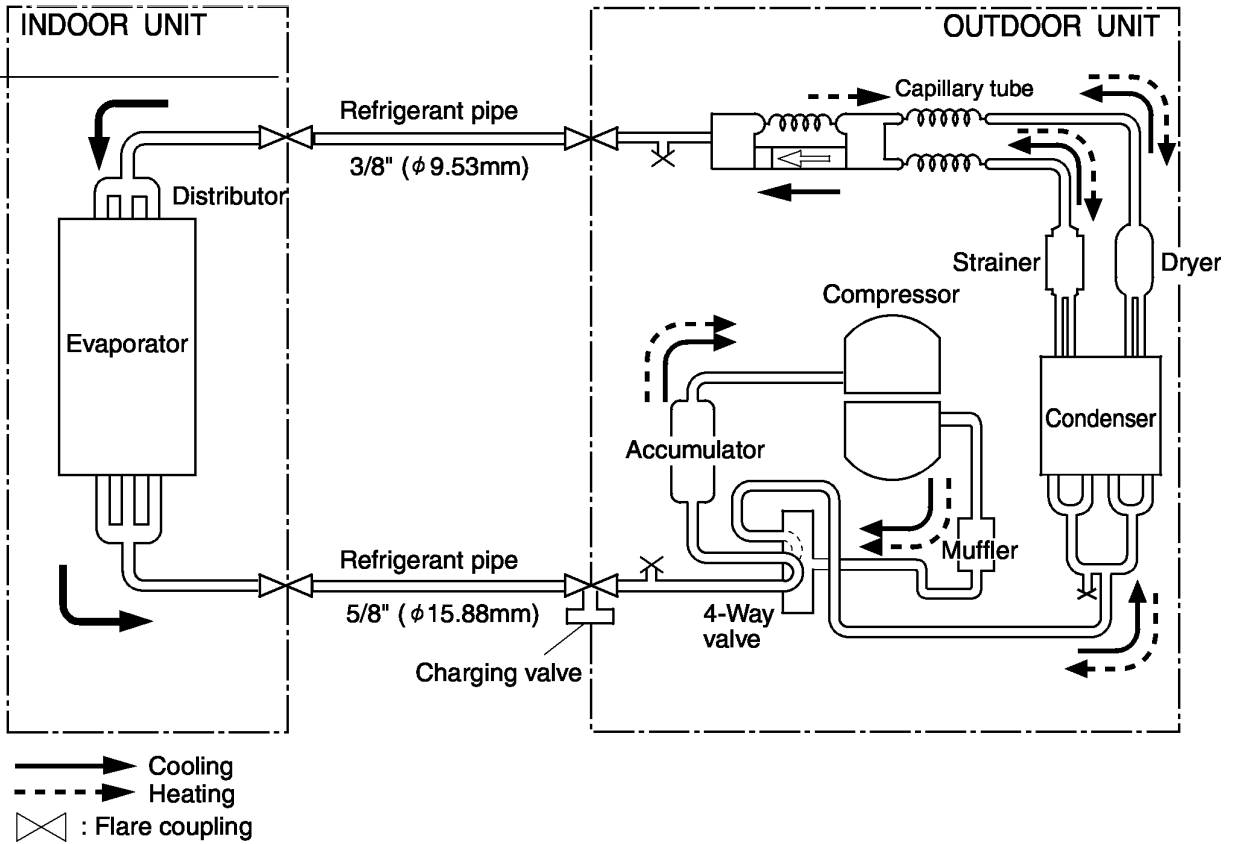

Model: MW30C3E / MR30C3E

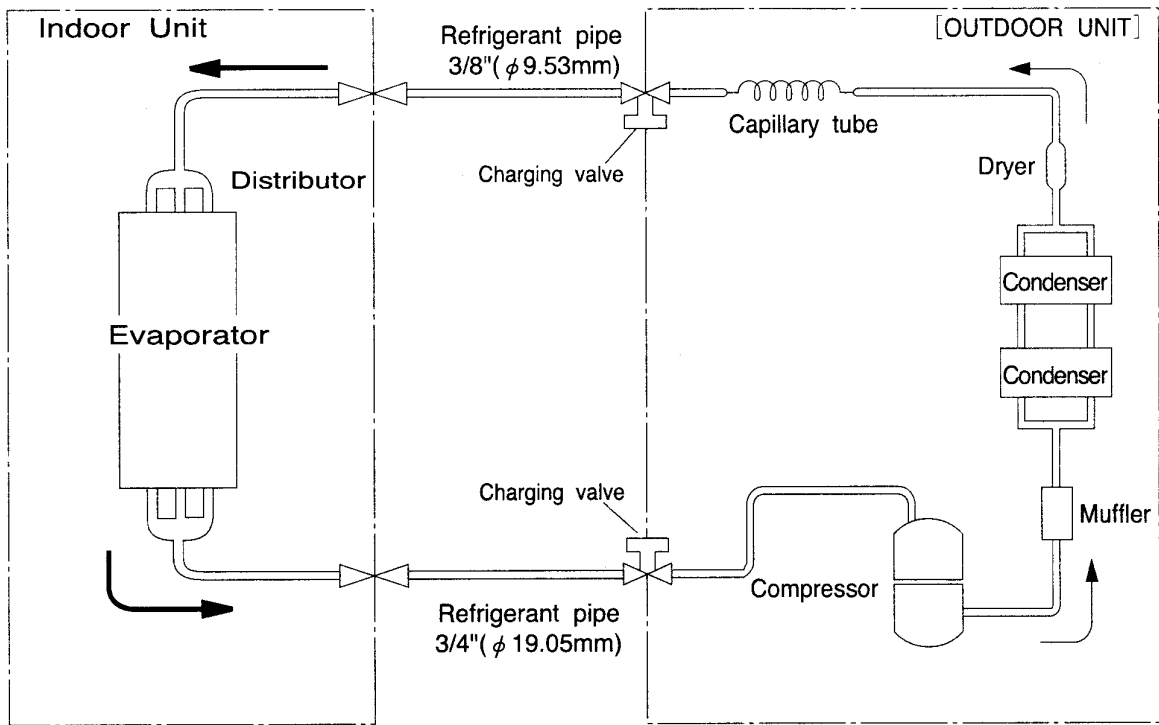

→ Cooling  
⊗ : Flare coupling

**Models : MW18C3E / MR18C3E-A**

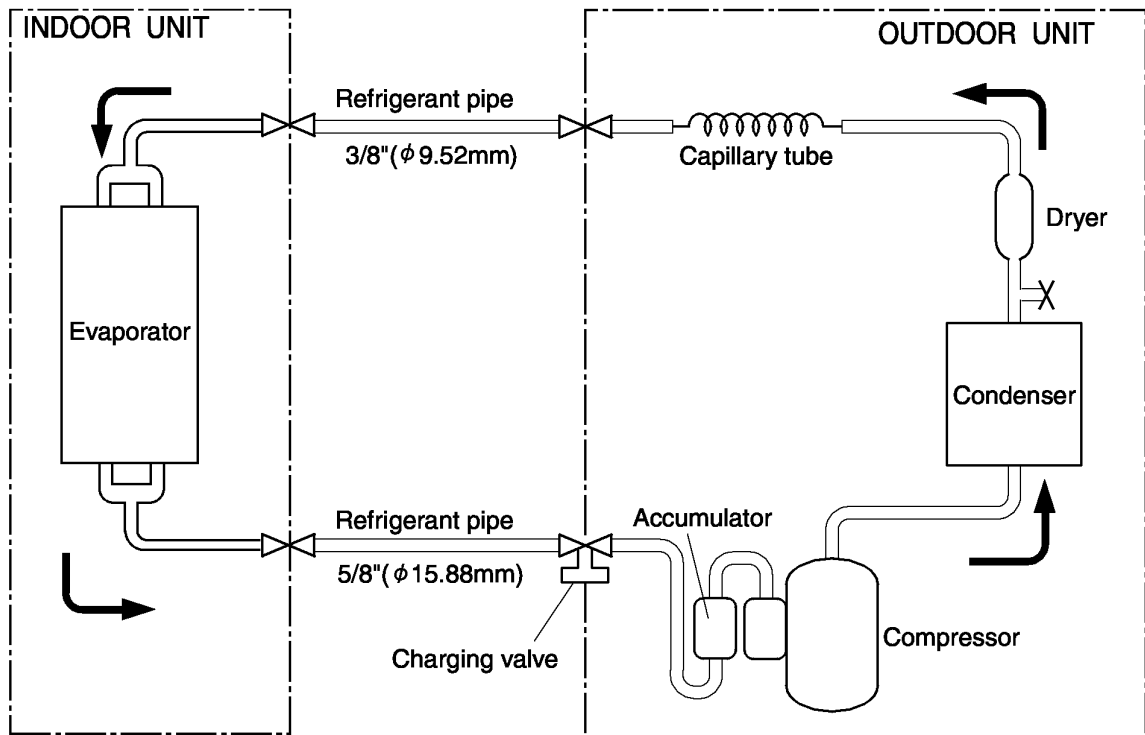

**Models : MW18Y3E / MR18Y3E-A**

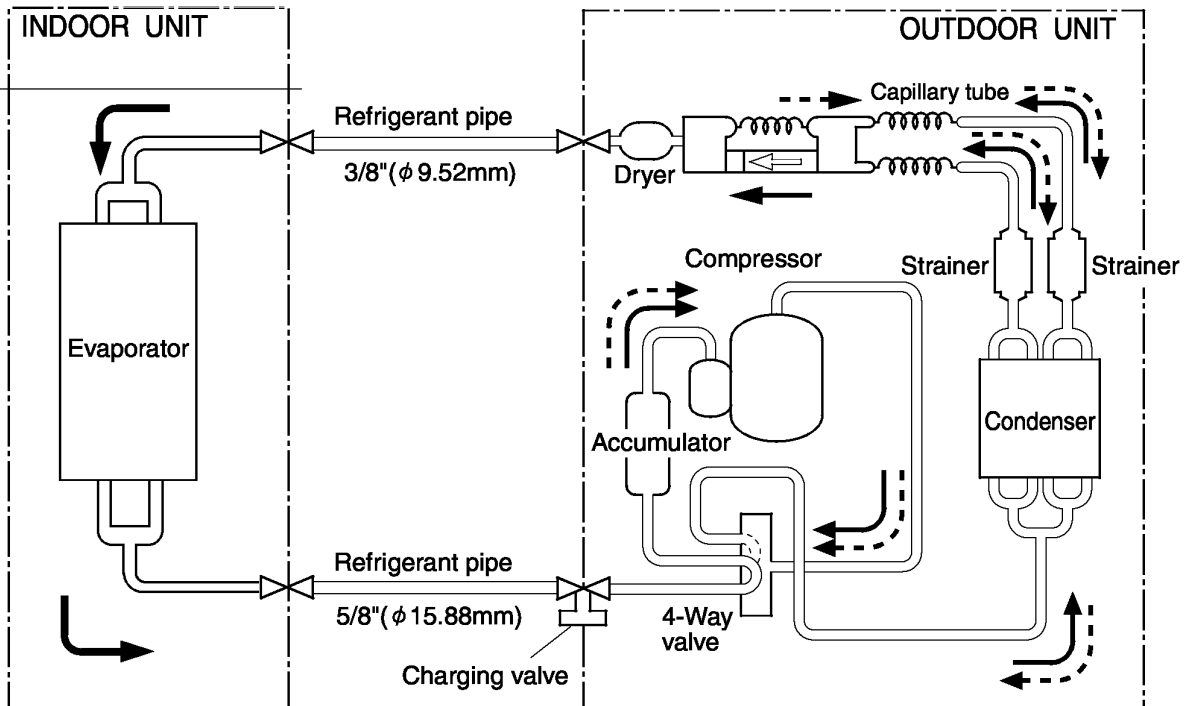

Cooling  
 Heating  
 : Flare coupling

Models : MW24C3E / MR24C3E-A

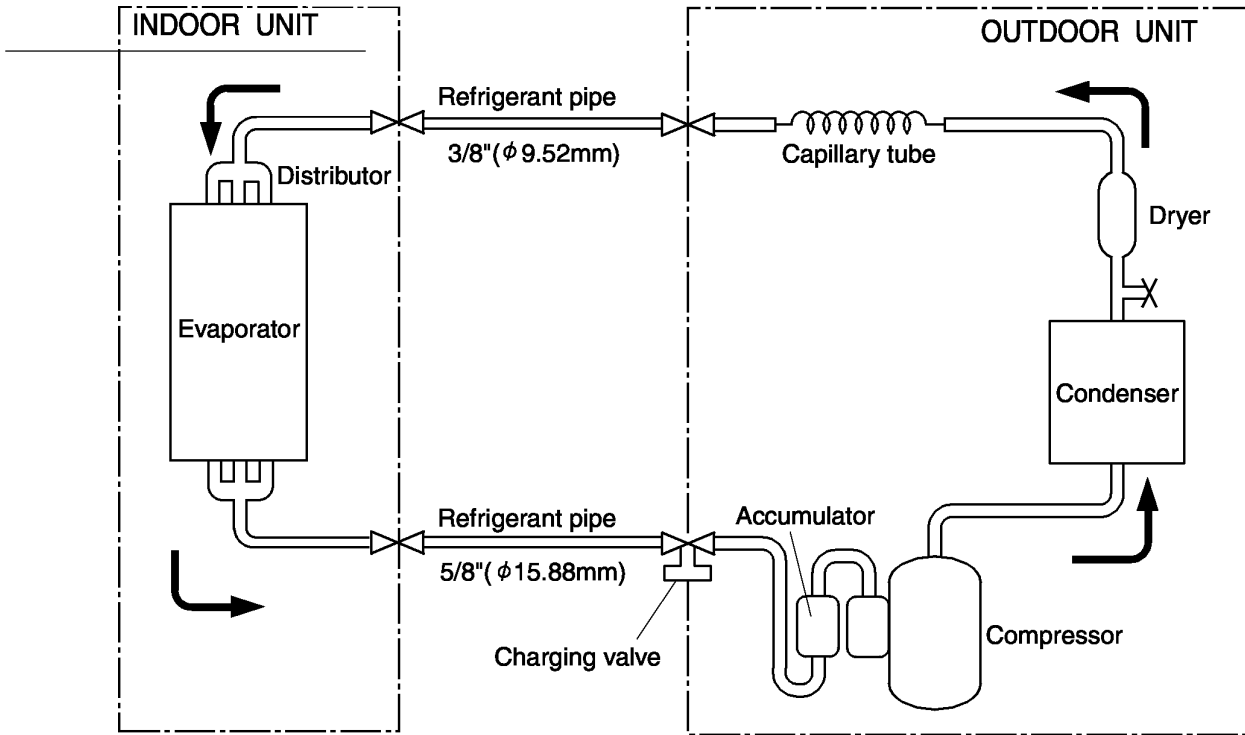

Models : MW24Y3E / MR24Y3E-A

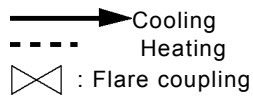
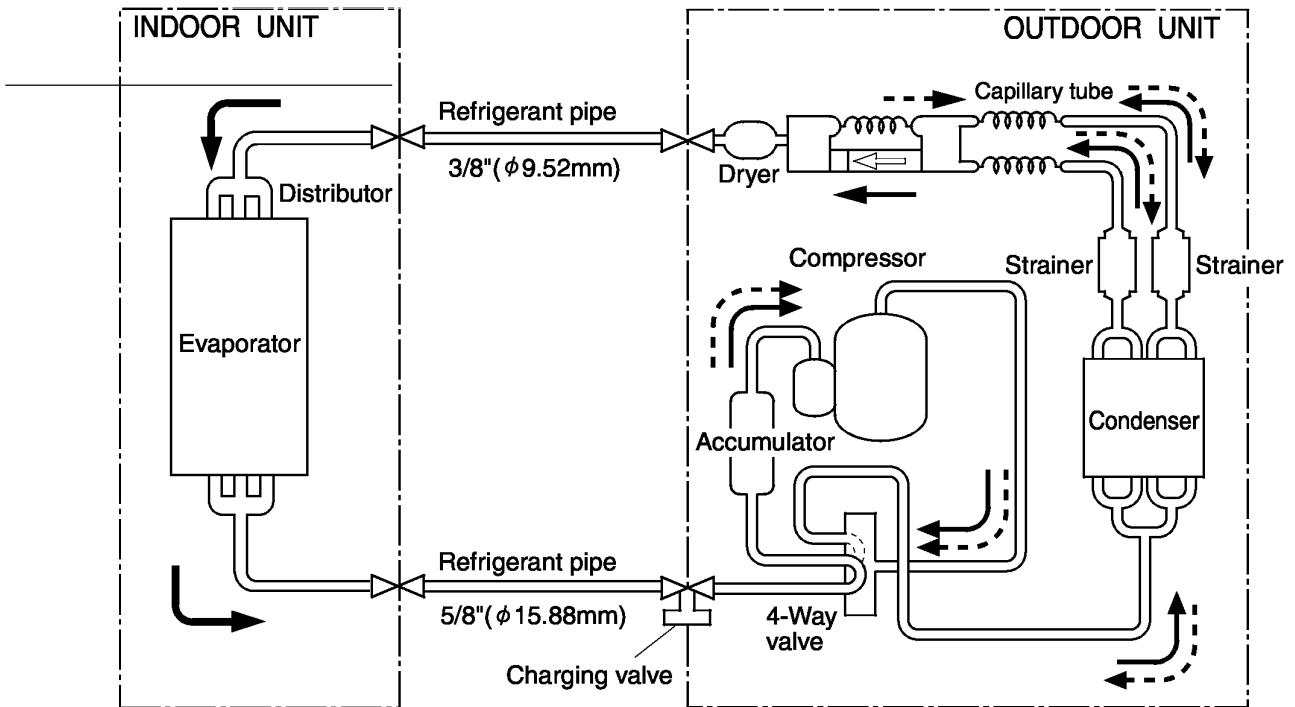



Models: MW18Y3E / MR18Y3E  
 MW24Y3E / MR24Y3E

INDOOR UNIT

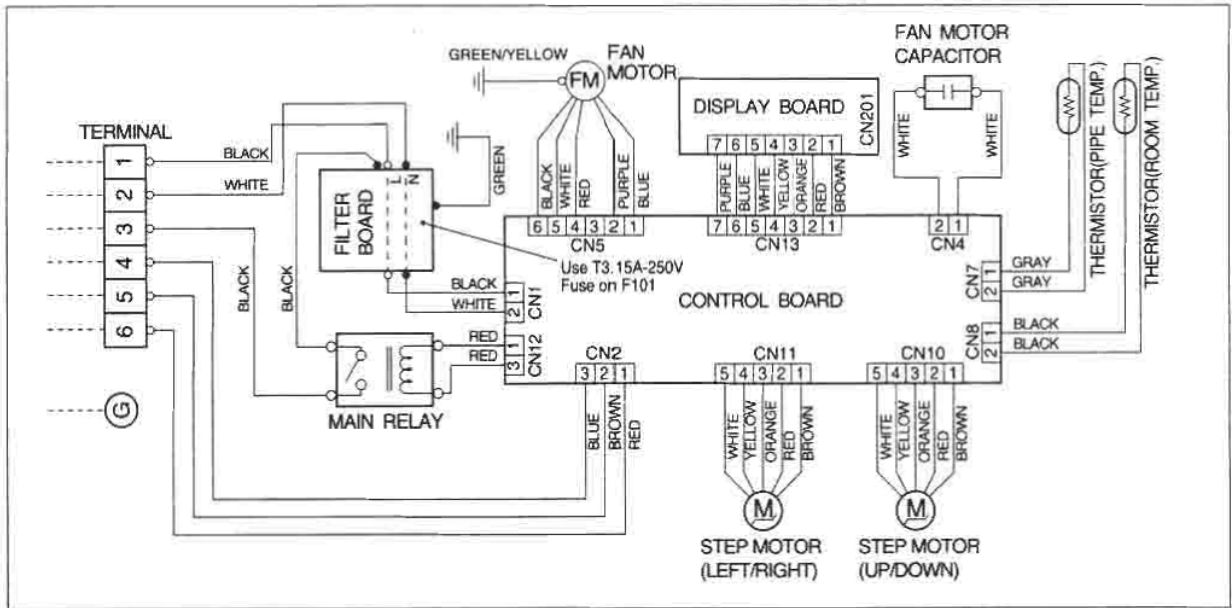

OUTDOOR UNIT

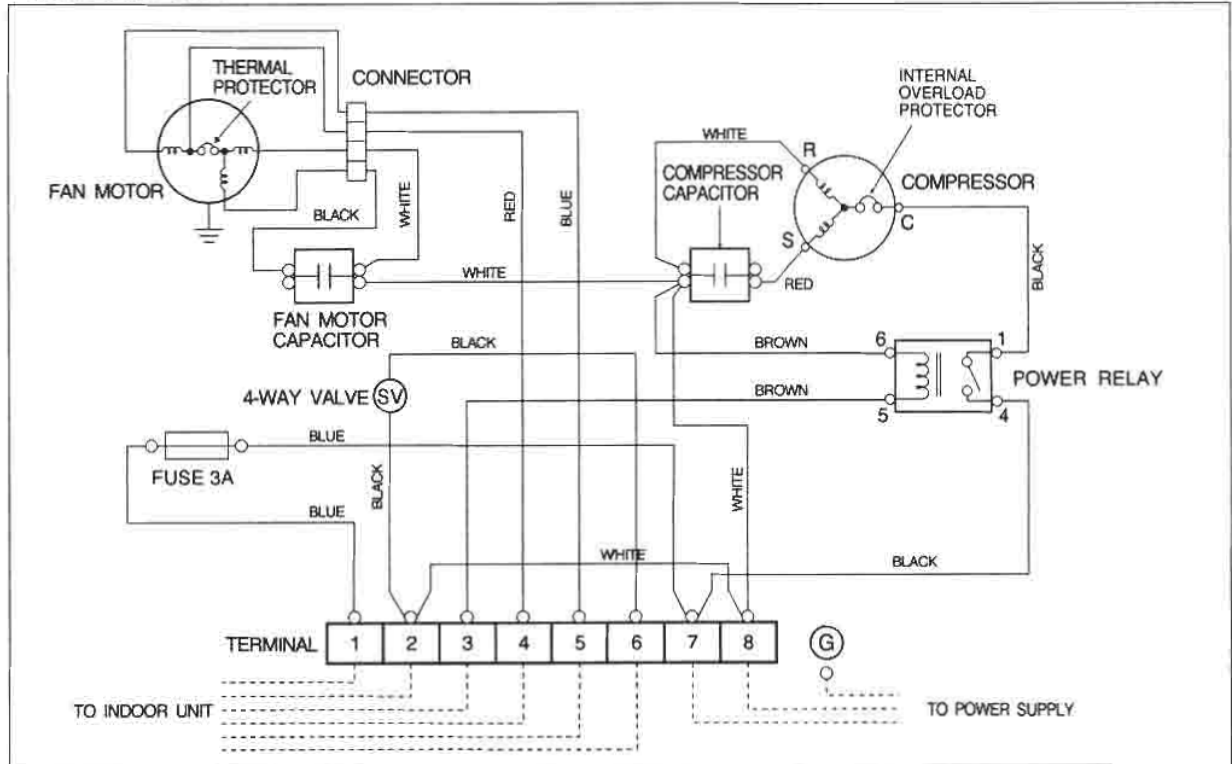



Models: MW18C3E / MR18C3E-A  
 MW24C3E / MR24C3E-A

**INDOR UNIT**

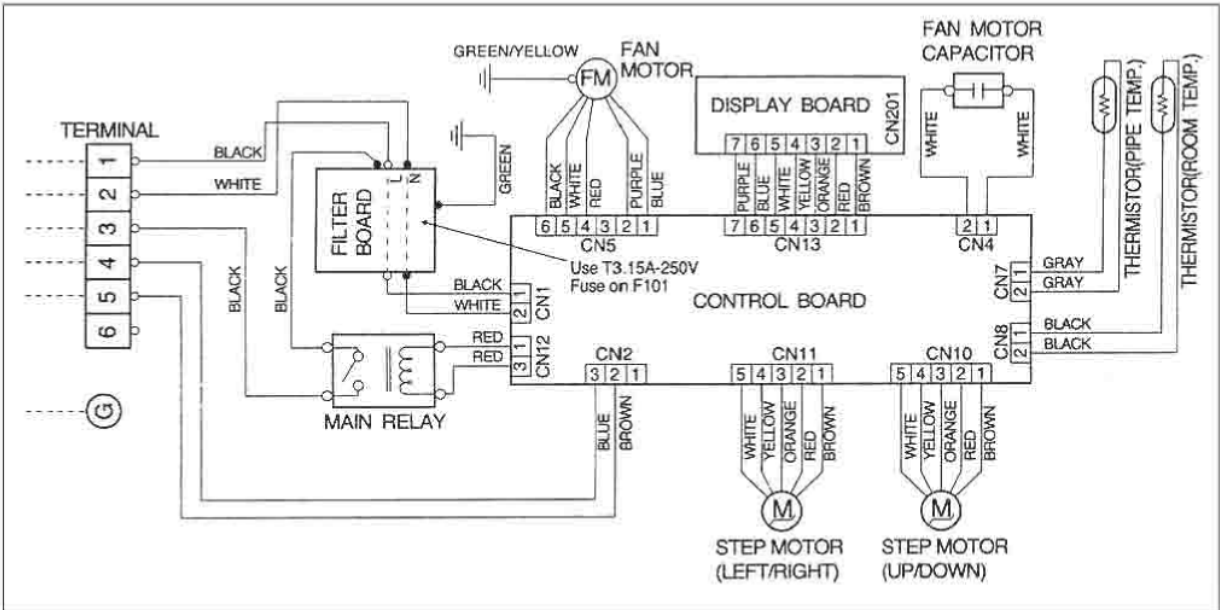

**OUTDOOR UNIT**

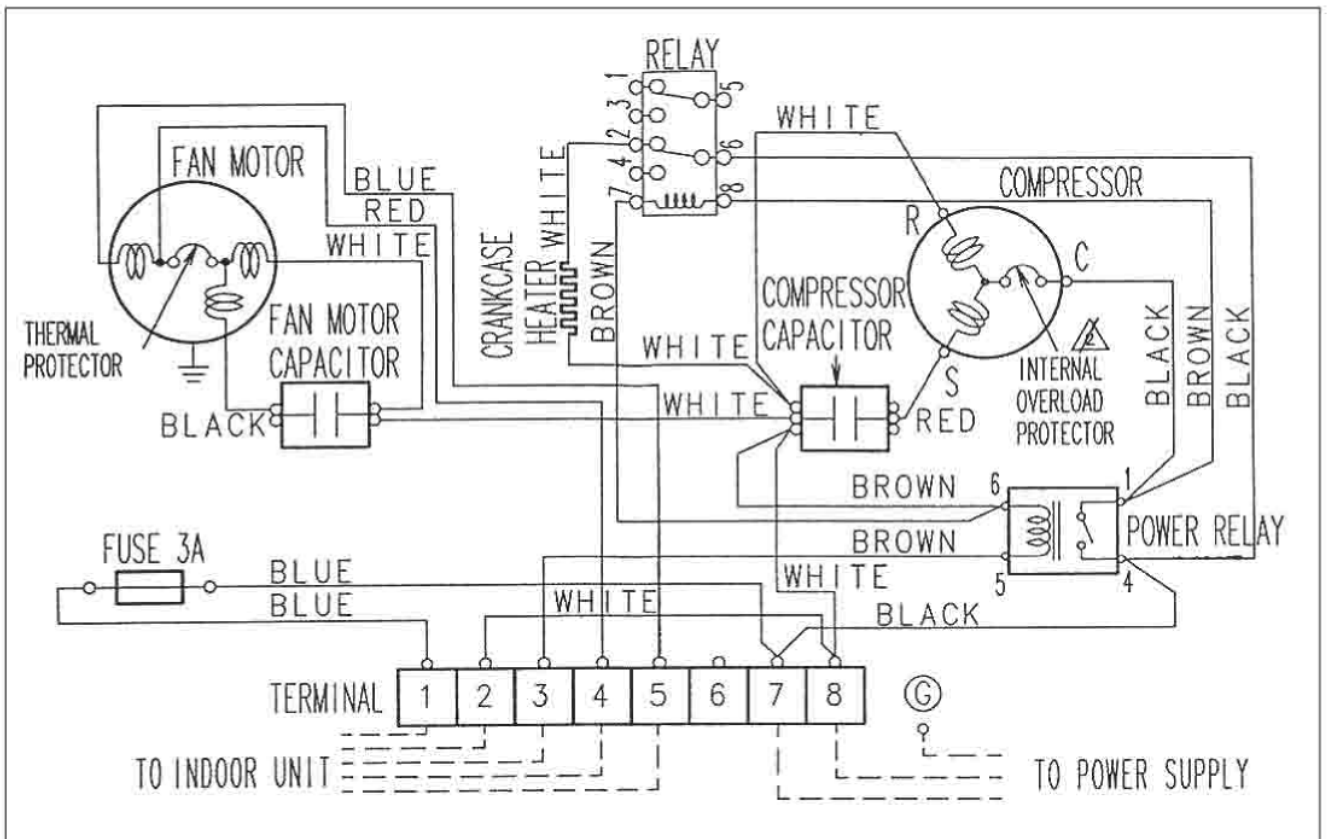

Models: MW18Y3E, MR18Y3E-A  
 MW24Y3E, MR24Y3E-A

**INDOOR UNIT**

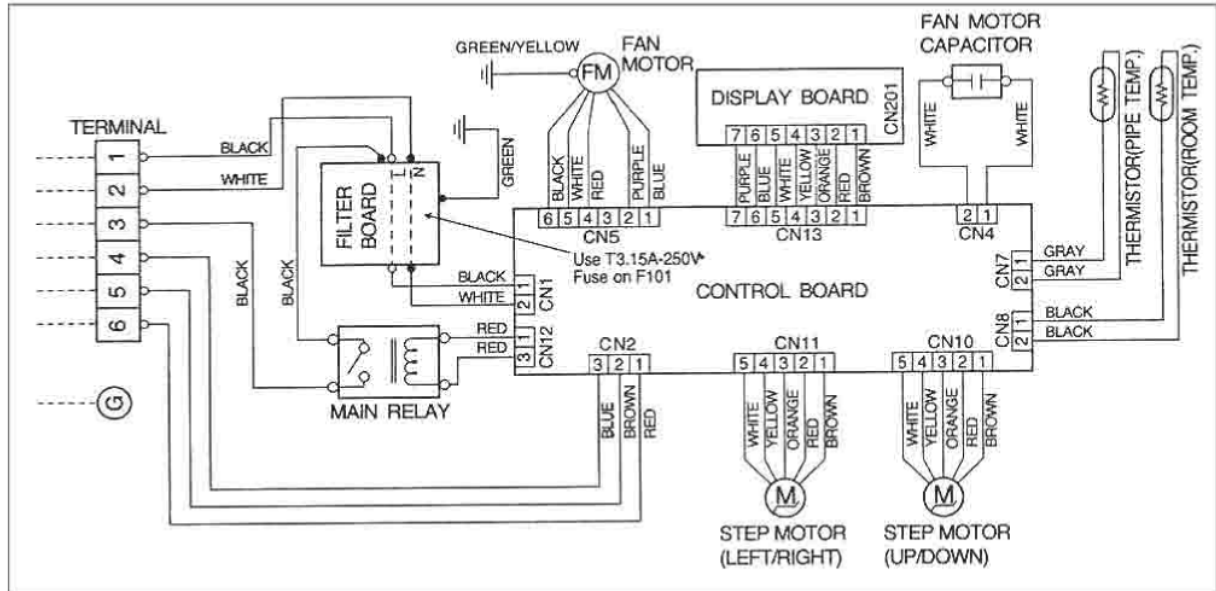

**OUTDOOR UNIT**

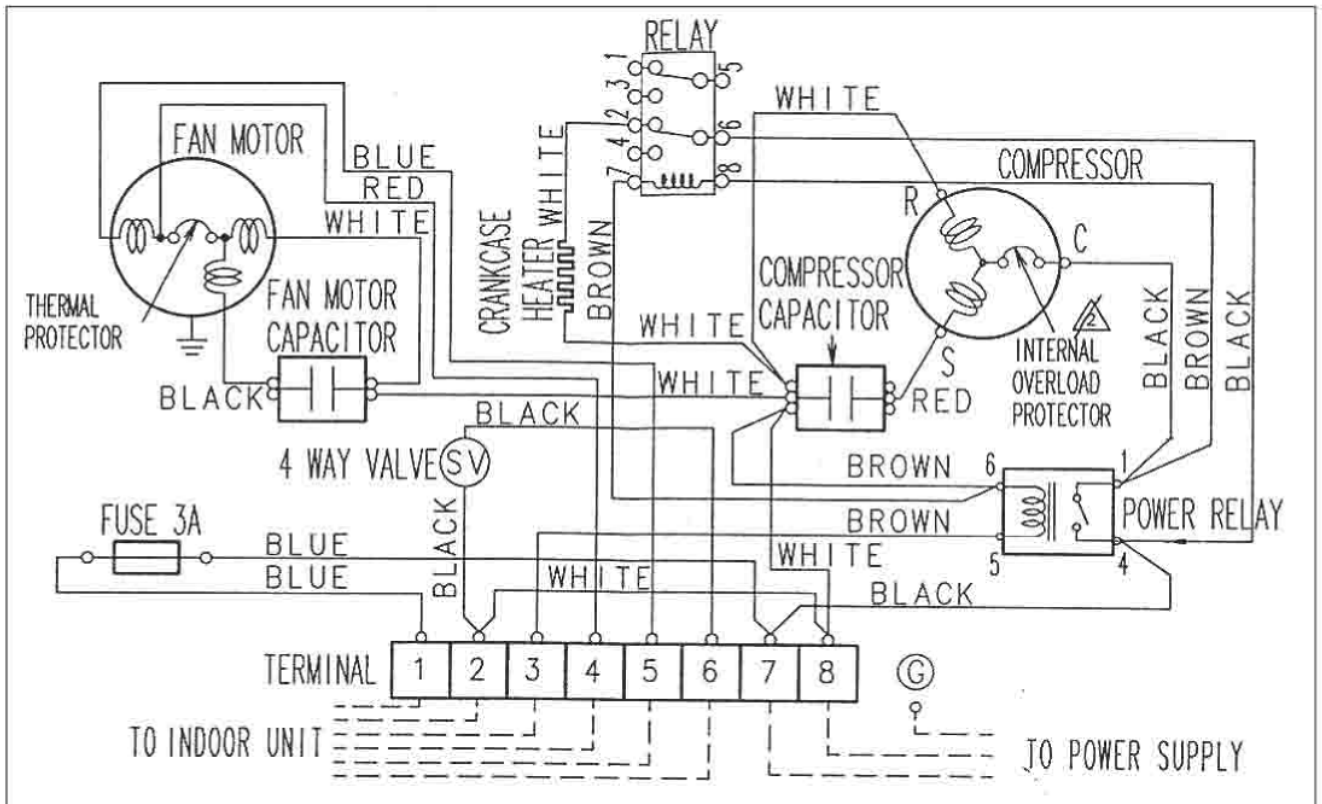

Models: MW18C3E / MR18C3E, MR18C3E-A  
 MW24C3E / MR24C3E, MR24C3E-A

# INDOOR PRINT CIRCUIT

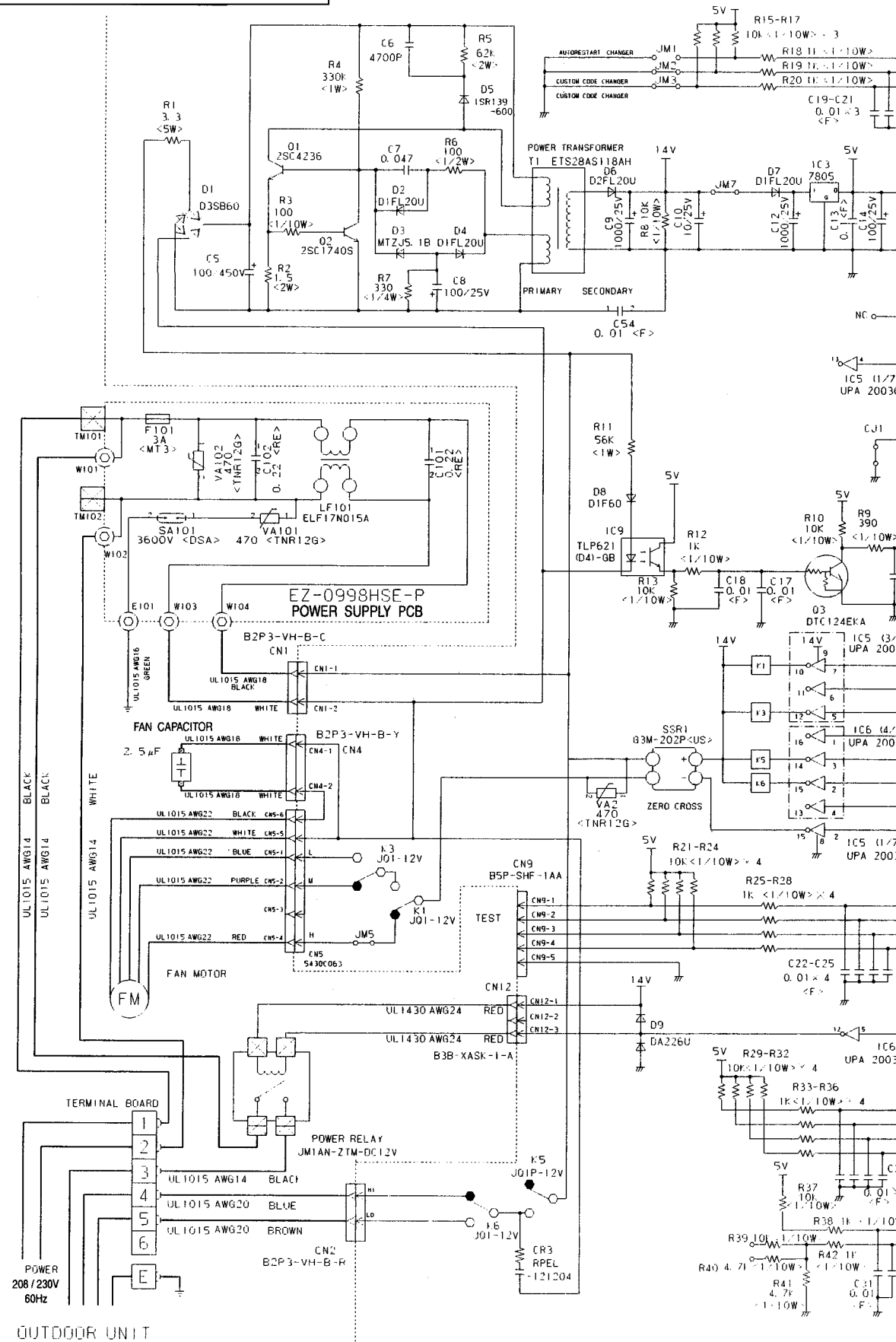

Models: MW18Y3E / MR18Y3E, MR18Y3E-A  
 MW24Y3E / MR24Y3E, MR24Y3E-A

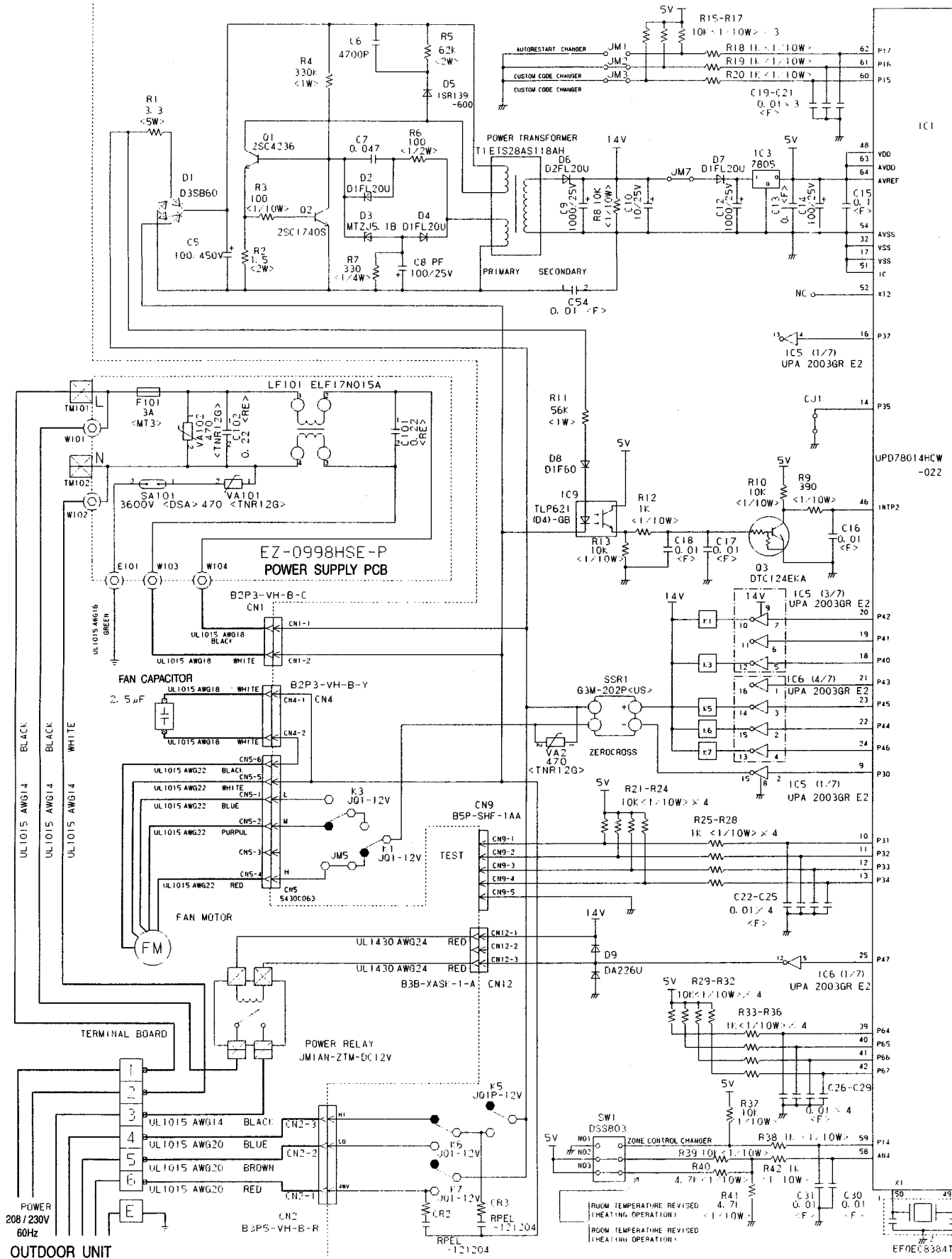

Models: MW30C3E / MR30C3E

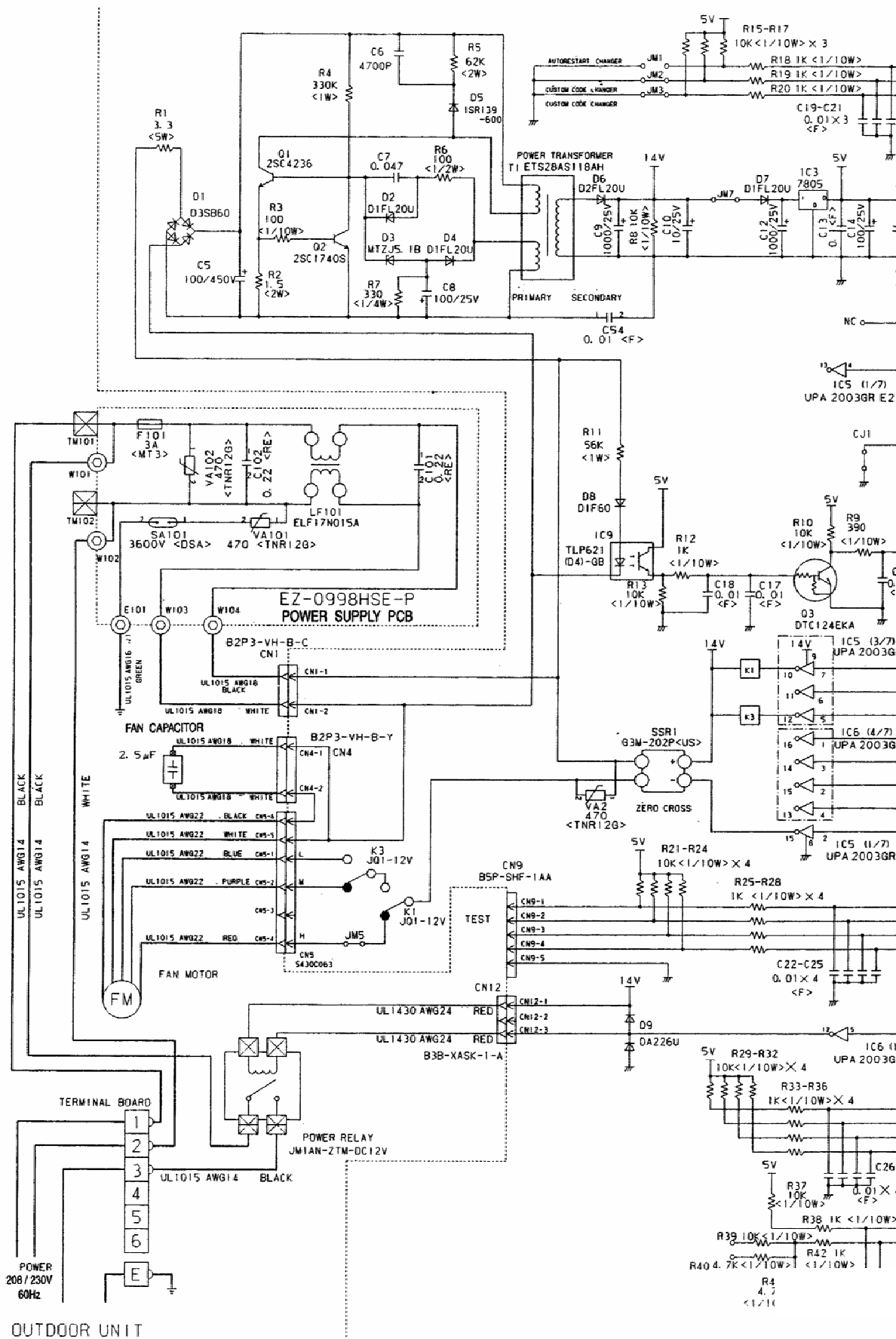

# E R R O R   D I S P L A Y

Operation can be checked by lighting and flashing of the display section OPERATION and TIMER lamps. Perform judgment in accordance with the following.

### Test running

When the air conditioner is run by pressing the remote control unit test run button, the OPERATION and TIMER lamps flash slowly at the same time.

### Error

The OPERATION and TIMER lamps operate as follows (Table) according to the error contents.

**Table**

Error display		Error contents		
	0.5 sec		0.5 sec	
OPERATION LAMP	ON			Two quick flashes repeated
OPERATION LAMP	OFF			5 sec
TIMER LAMP	ON			0.1 sec ON/OFF repeated
TIMER LAMP	OFF			sec
OPERATION LAMP	ON			0.5
OPERATION LAMP	OFF			sec
TIMER LAMP	ON			0.1 sec ON/OFF repeated
TIMER LAMP	OFF			sec



Models: MW18C3E  
MW18Y3E  
MW24C3E  
MW24Y3E  
MW30C3E

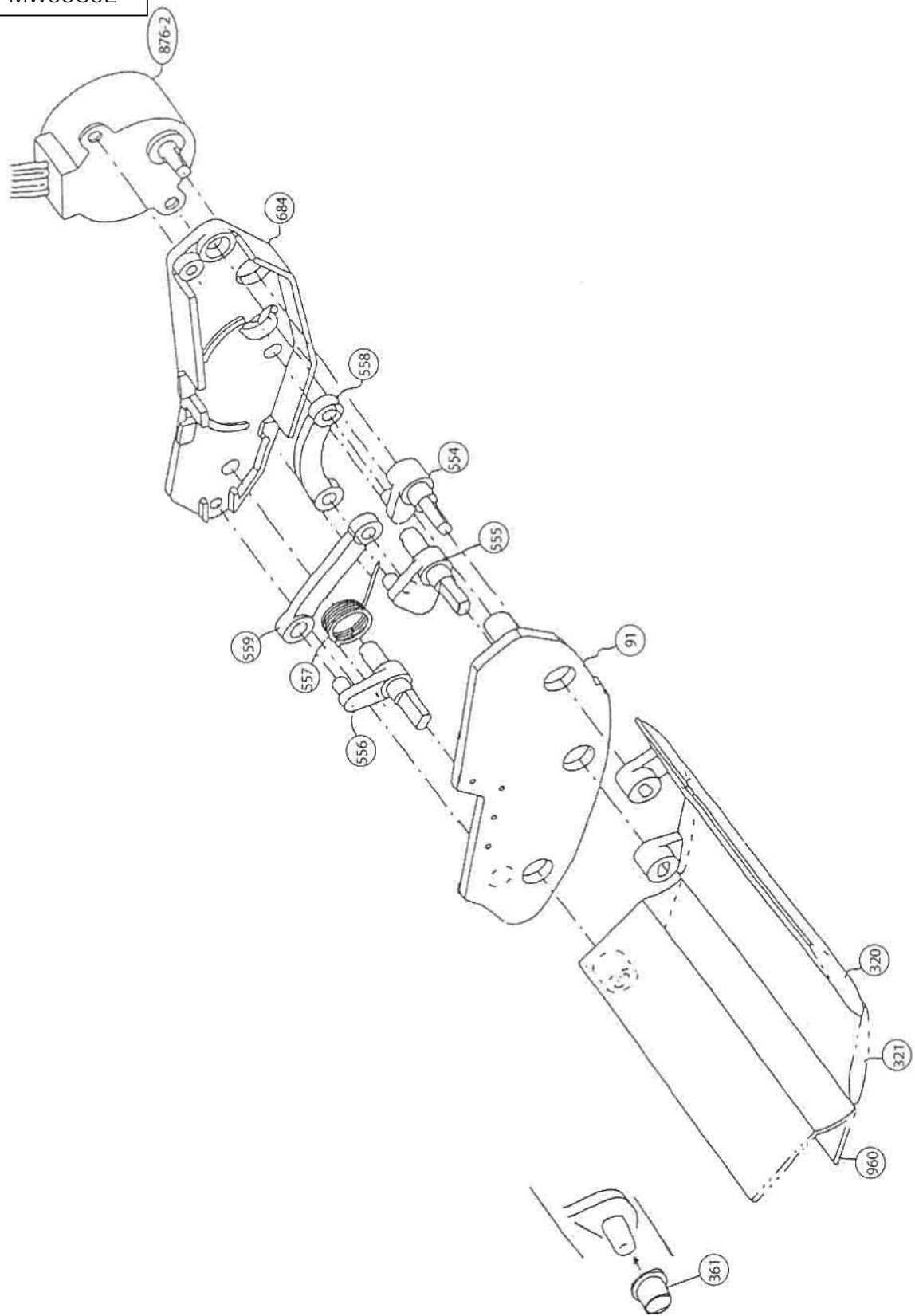

Models: MW18C3E  
MW18Y3E  
MW24C3E  
MW24Y3E  
MW30C3E

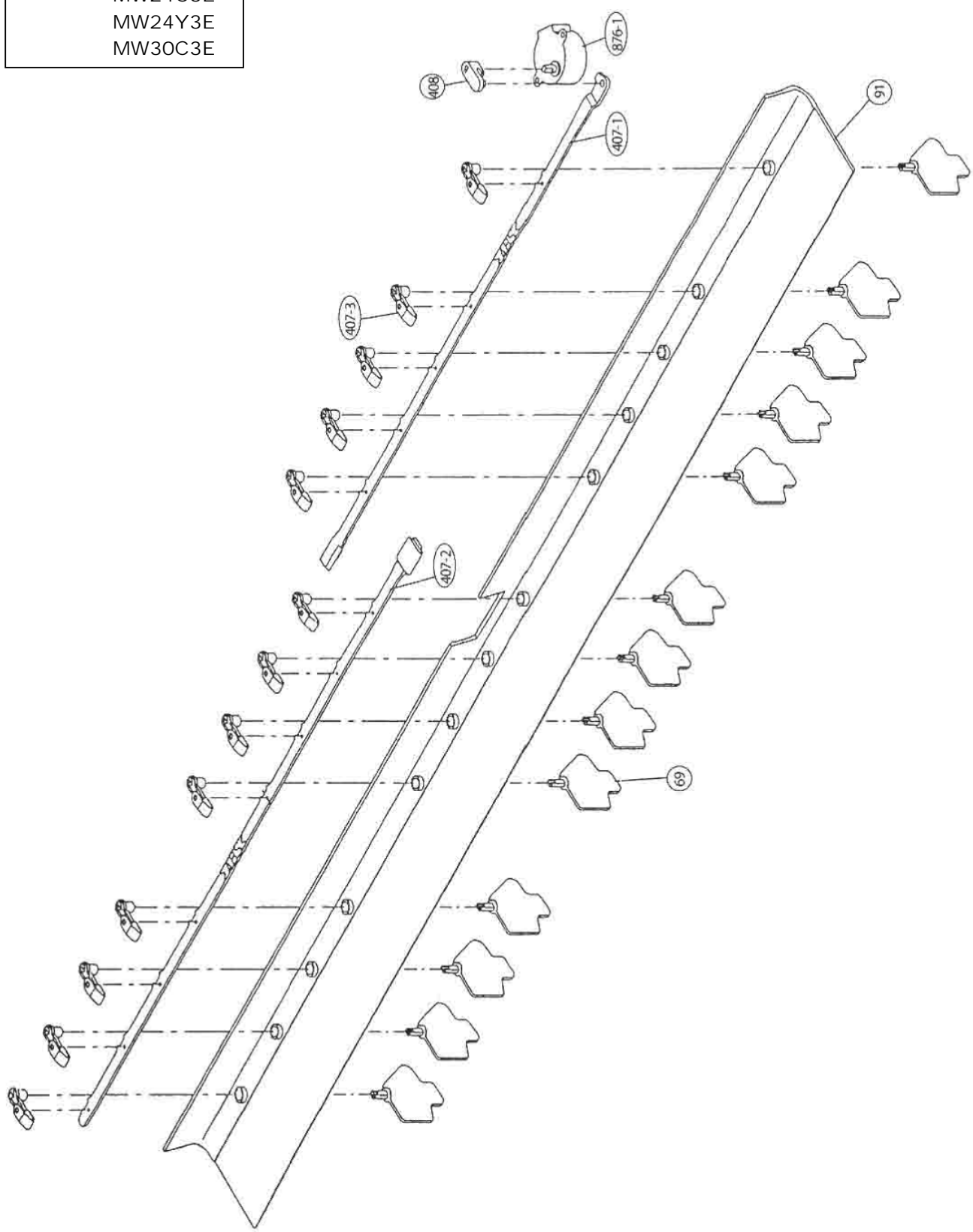

Models: MR18C3E, MR18C3E-A, MR18Y3E, MR18Y3E-A  
MR24C3E, MR24C3E-A, MR24Y3E, MR24Y3E-A

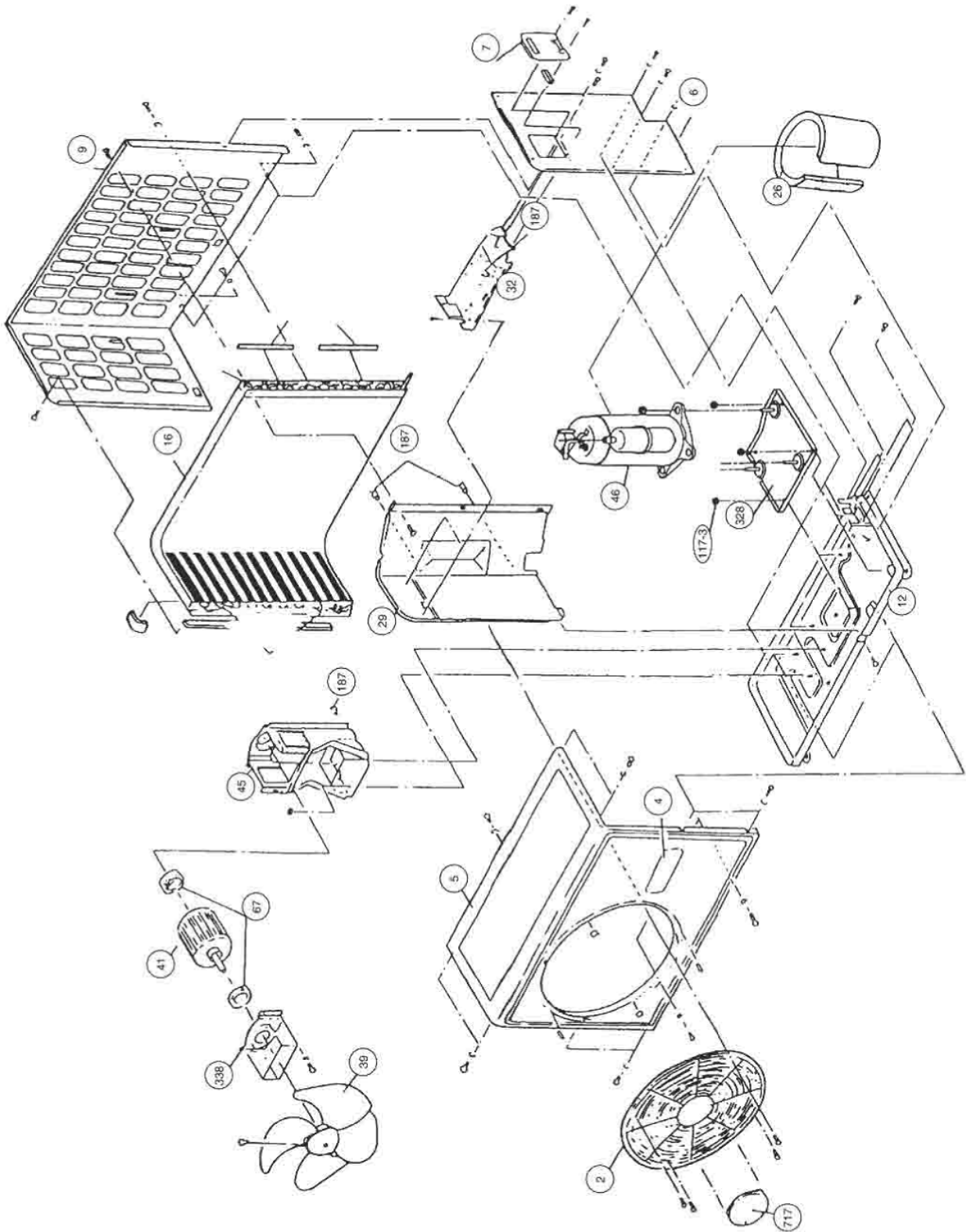

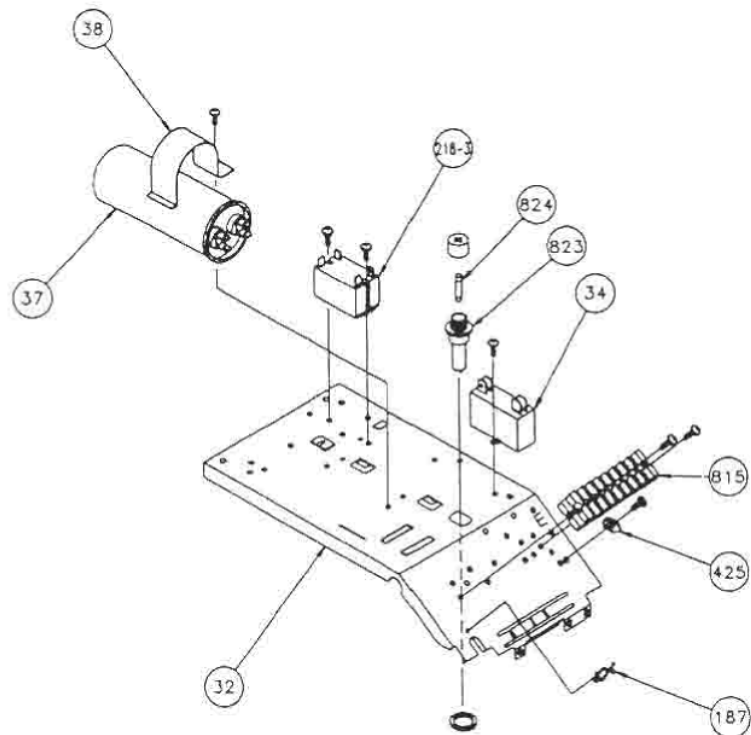
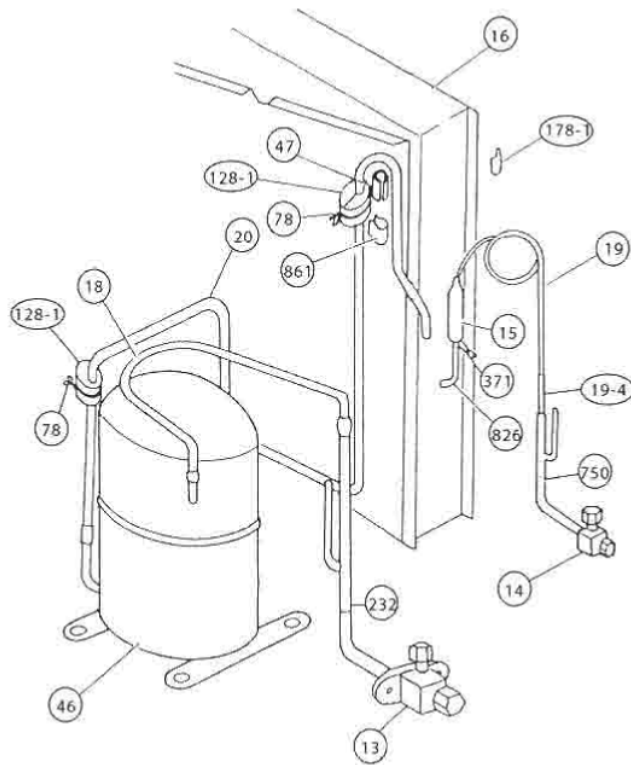

Models: MR18C3E-A

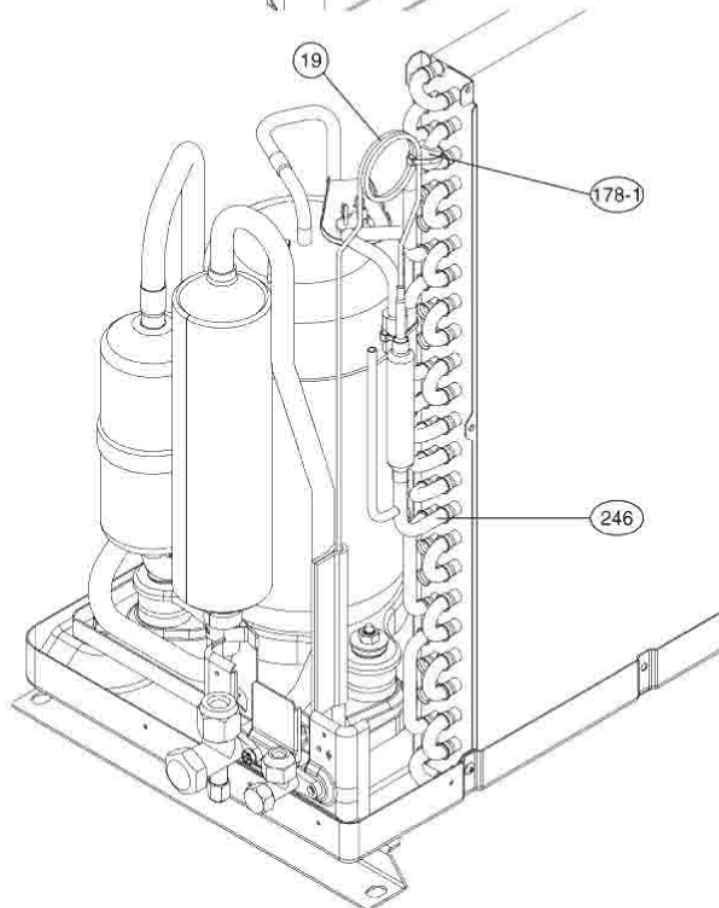
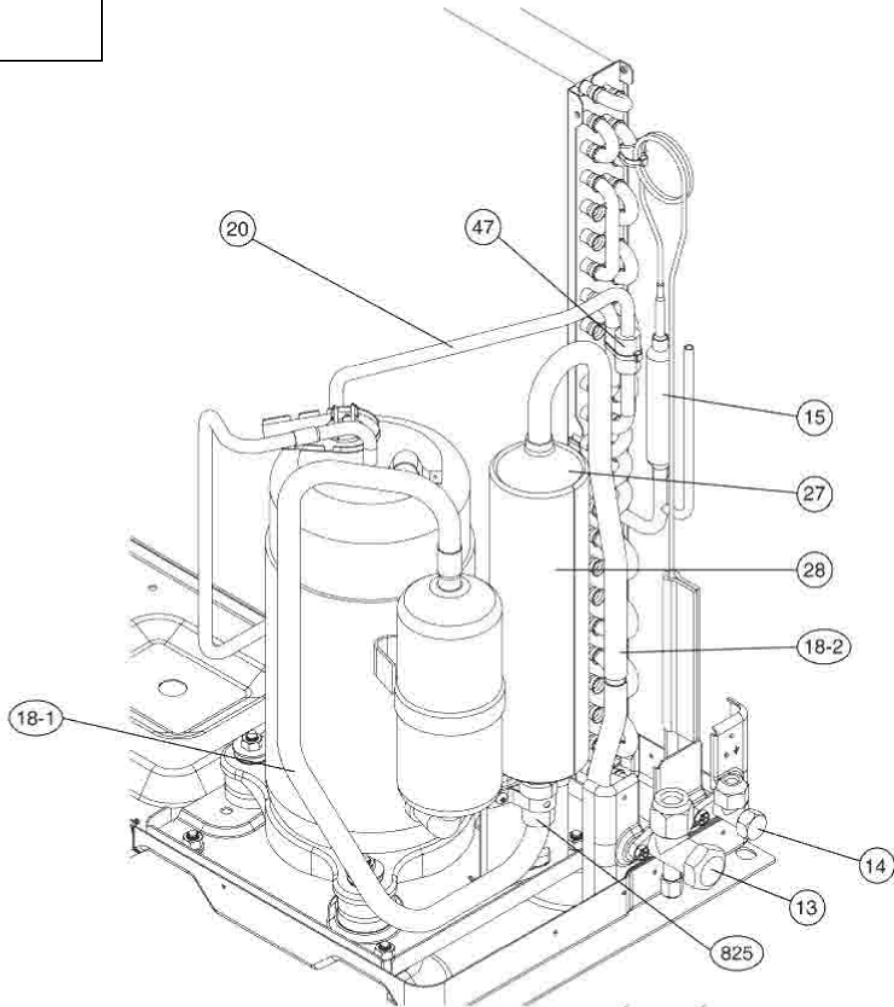

Model: MR18Y3E

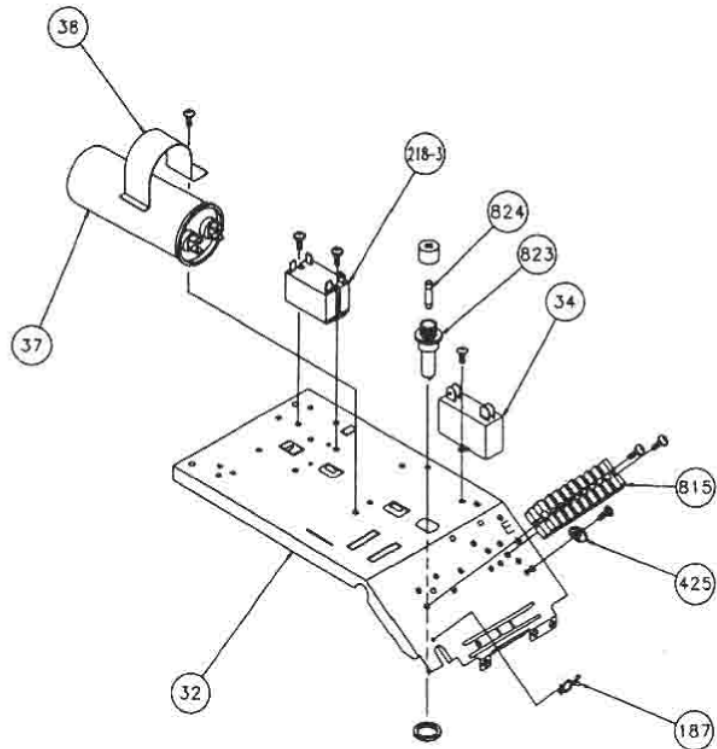
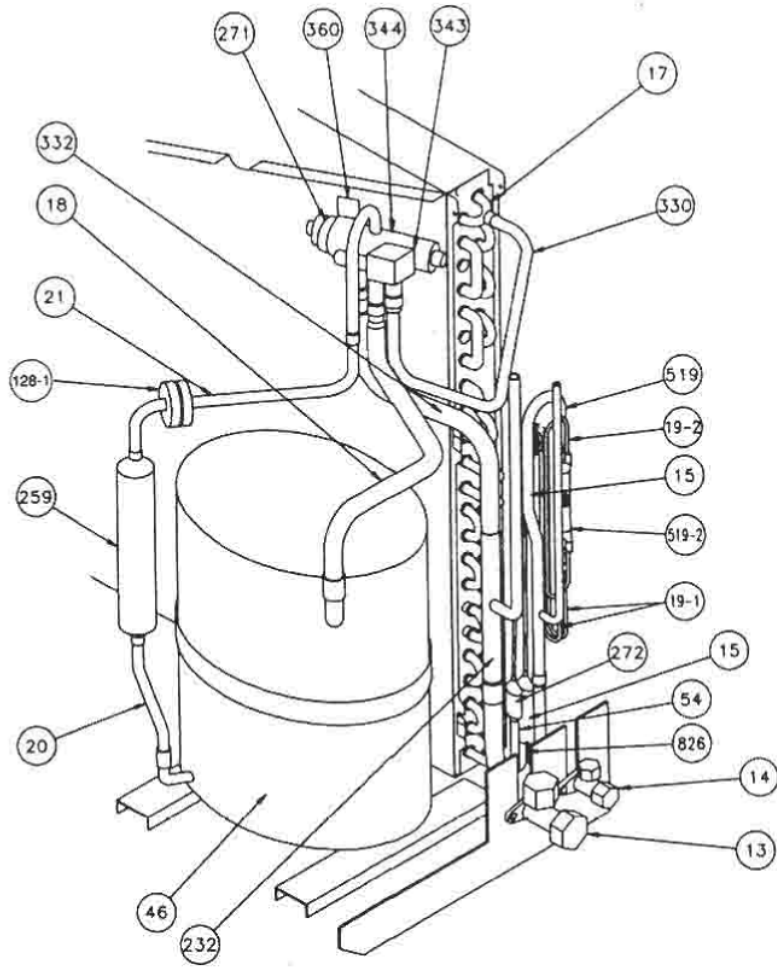

Model: MR18Y3E-A

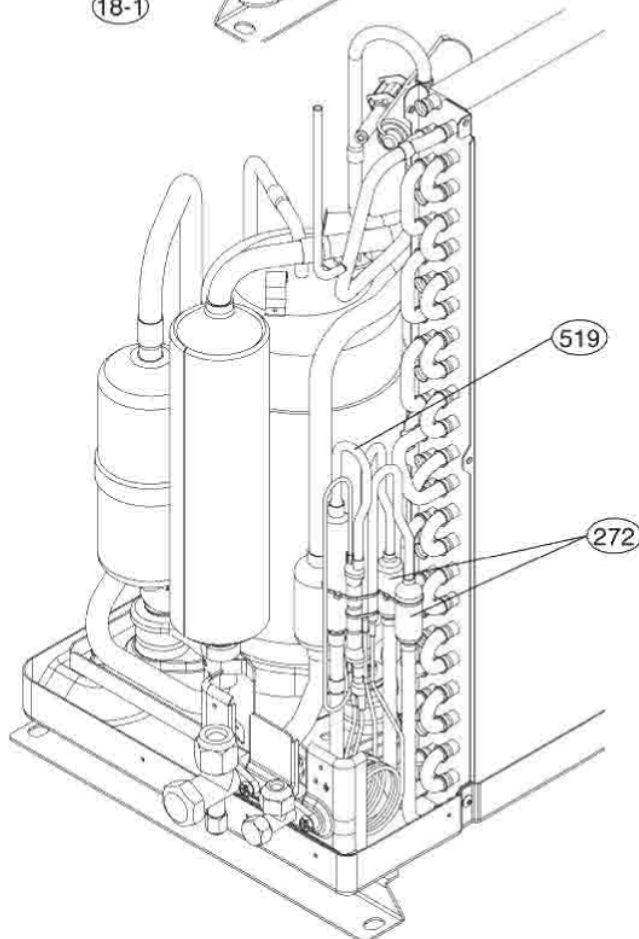
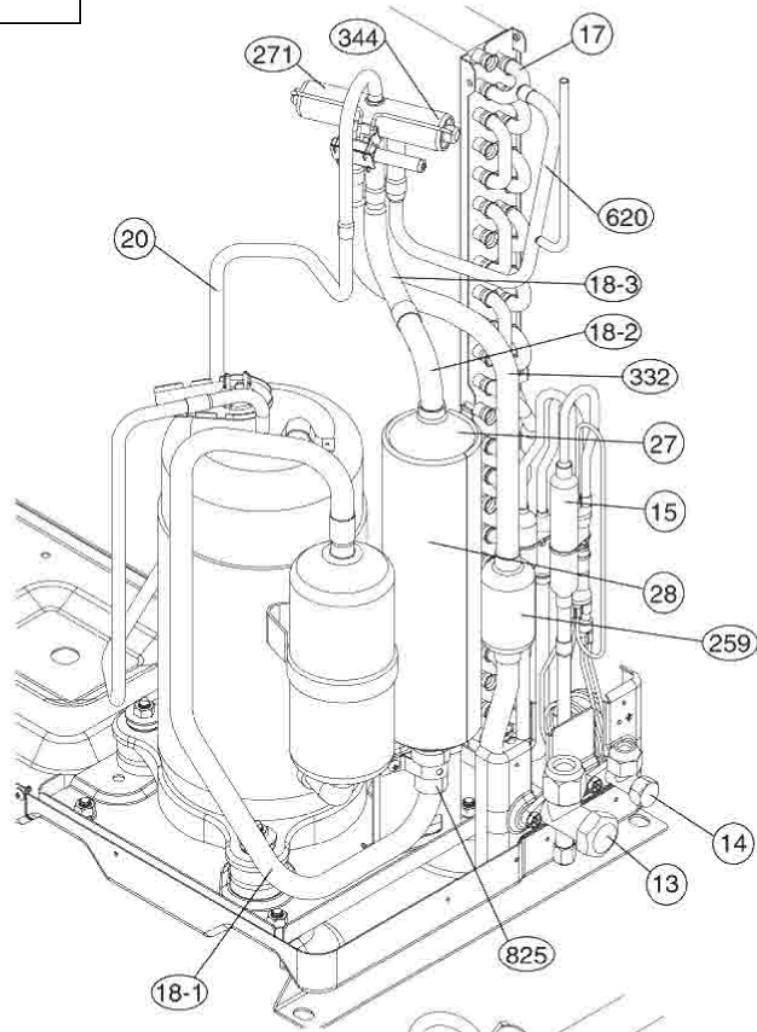

Model: MR24C3E

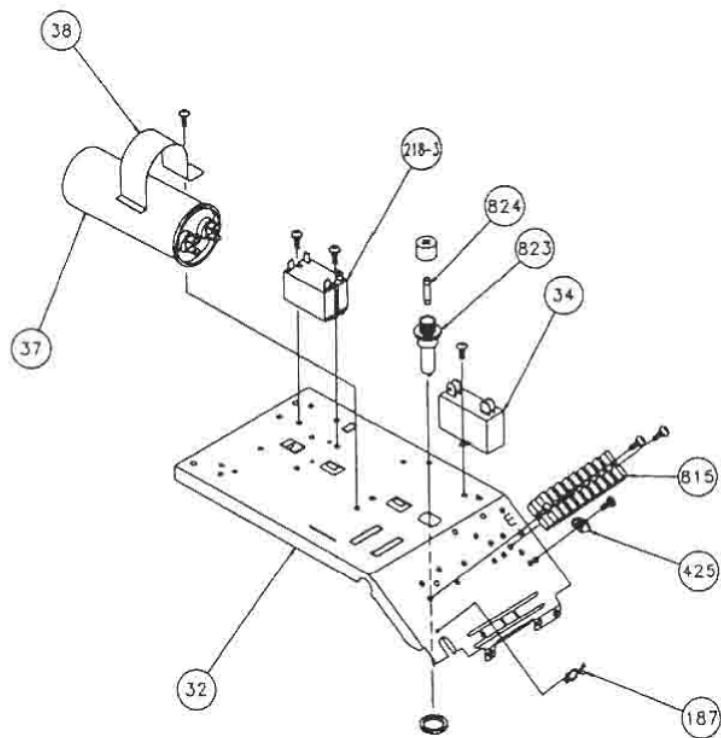
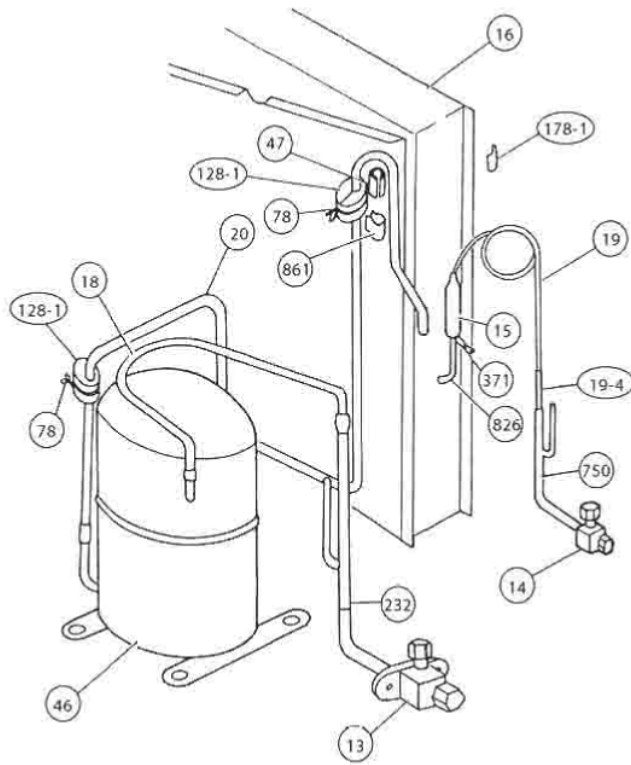

Model: MR24C3E-A

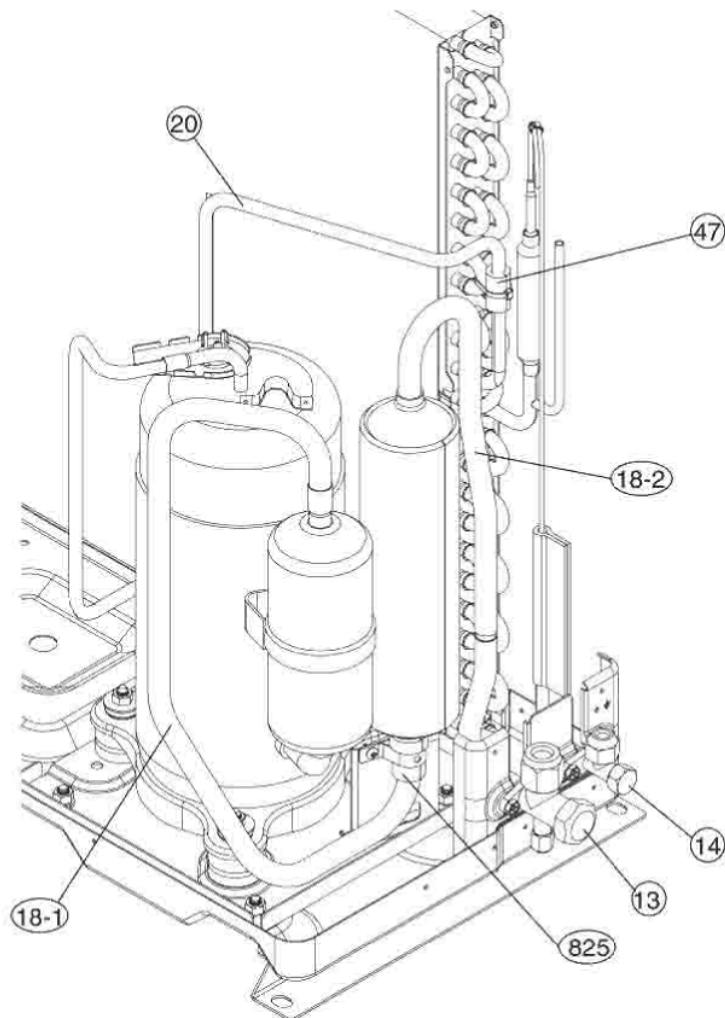
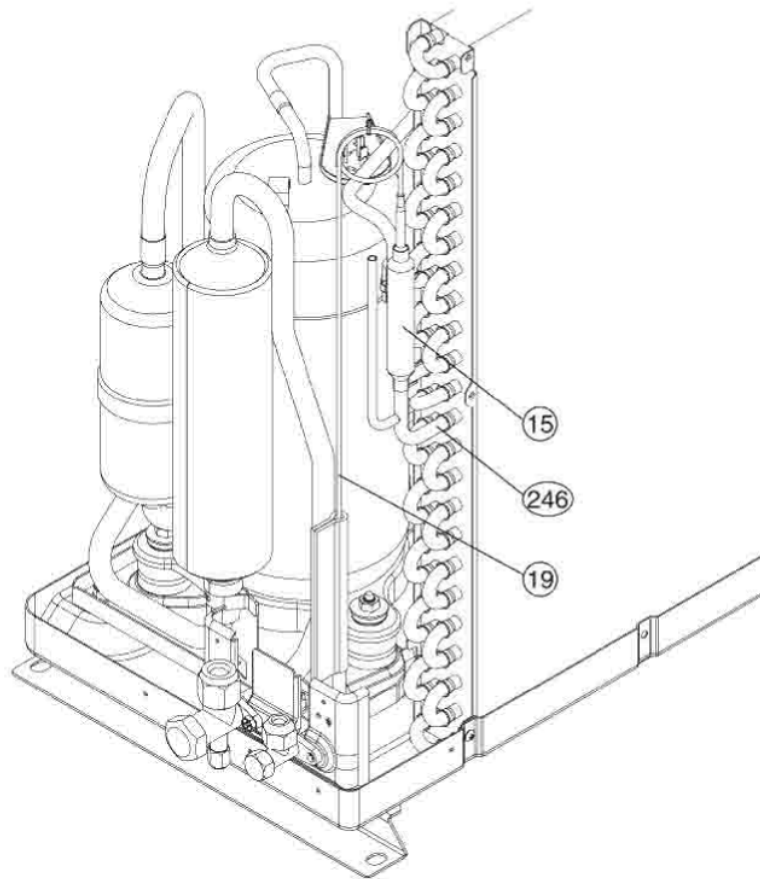

Model: MR24Y3E

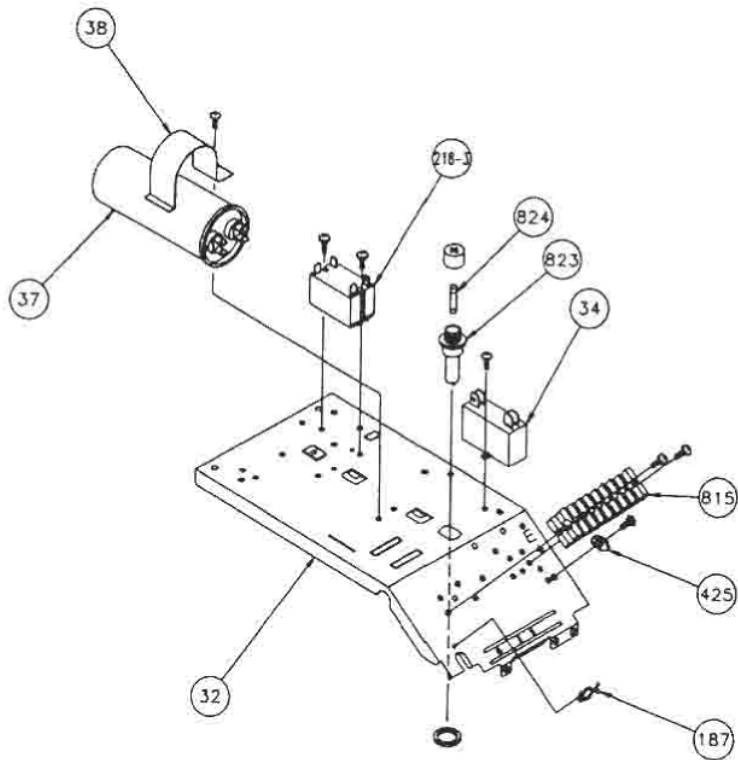
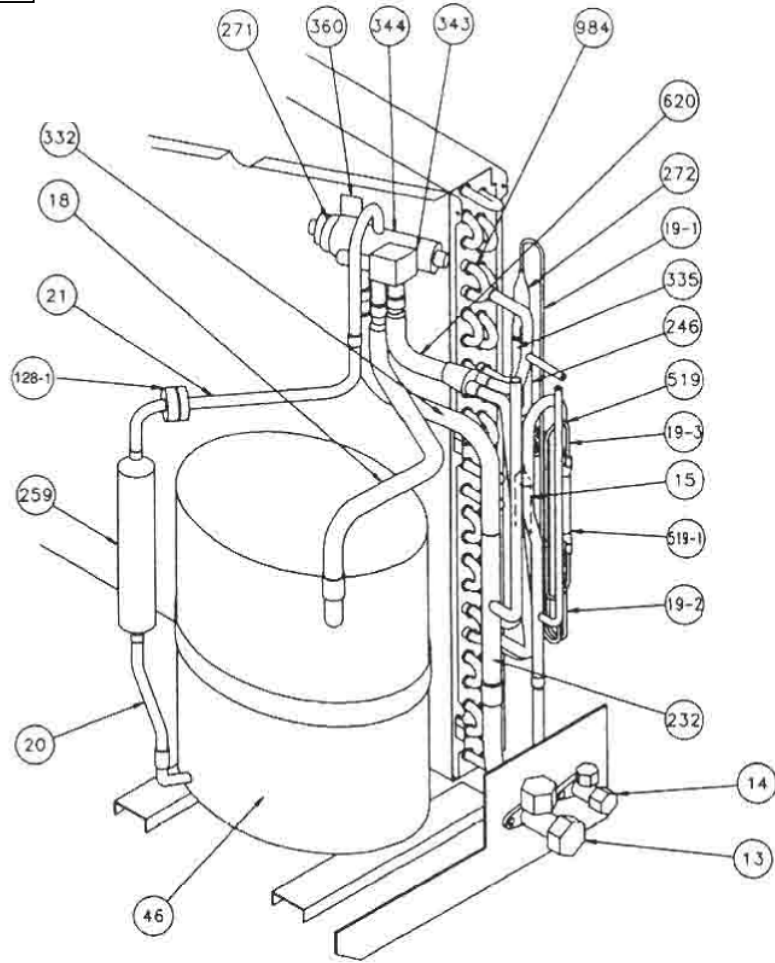

Model: MR24Y3E-A

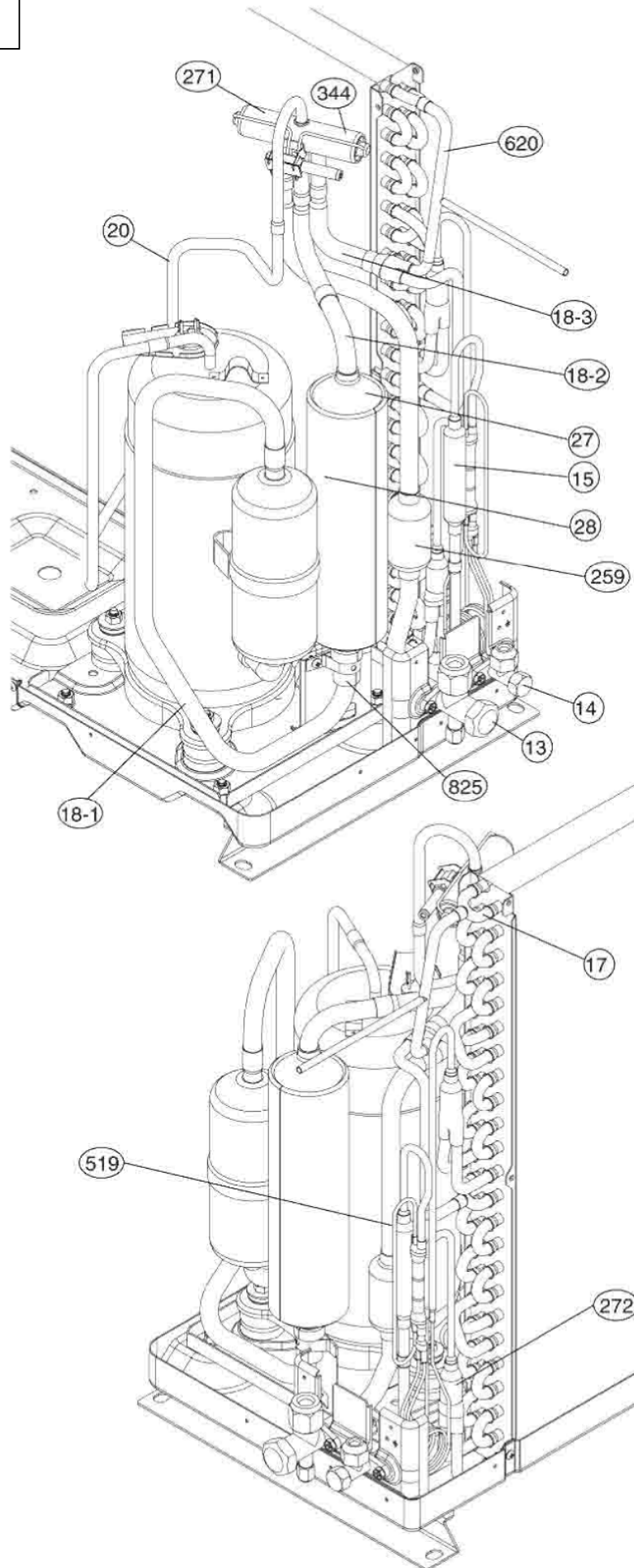

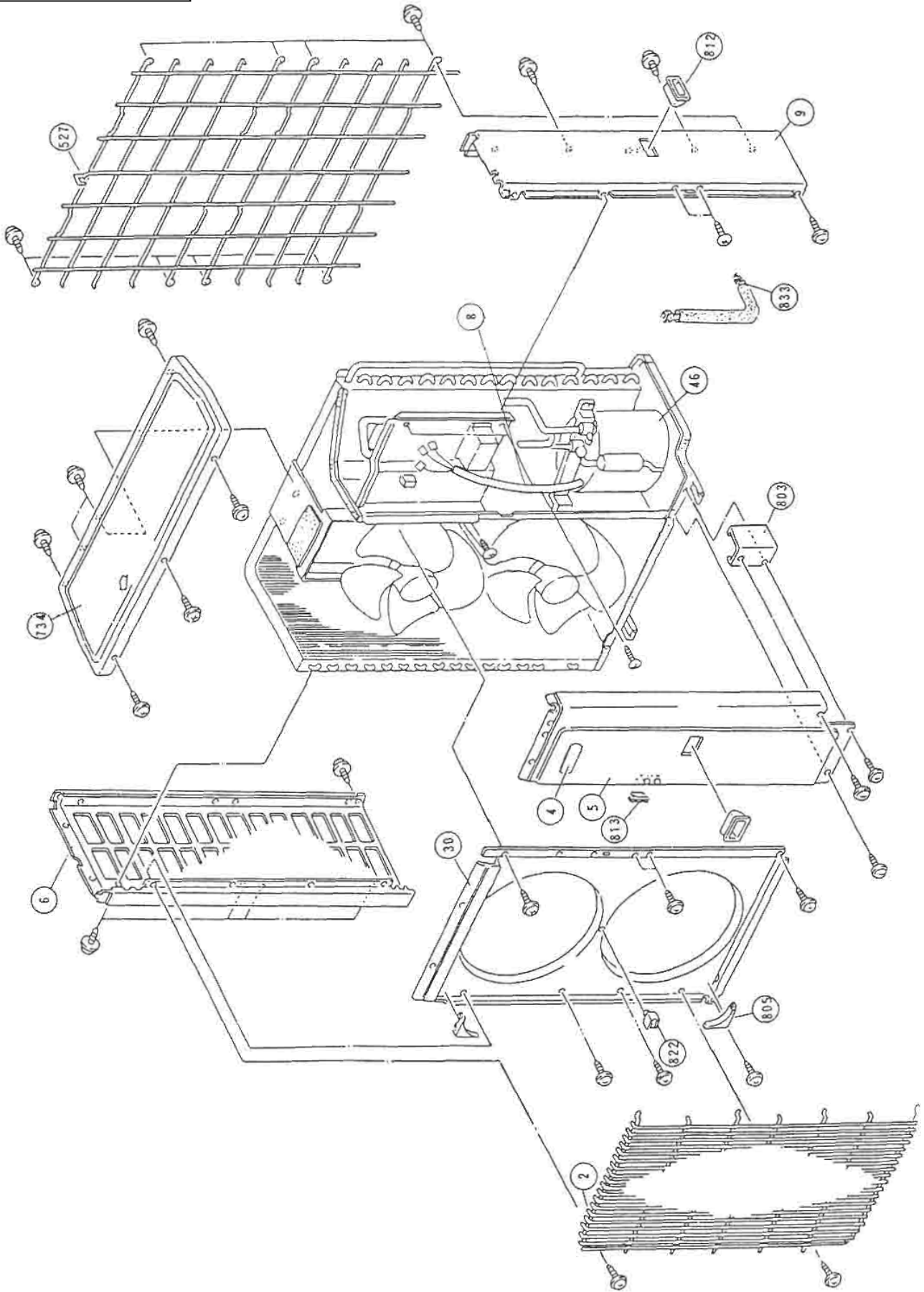

Models: MR30C3E

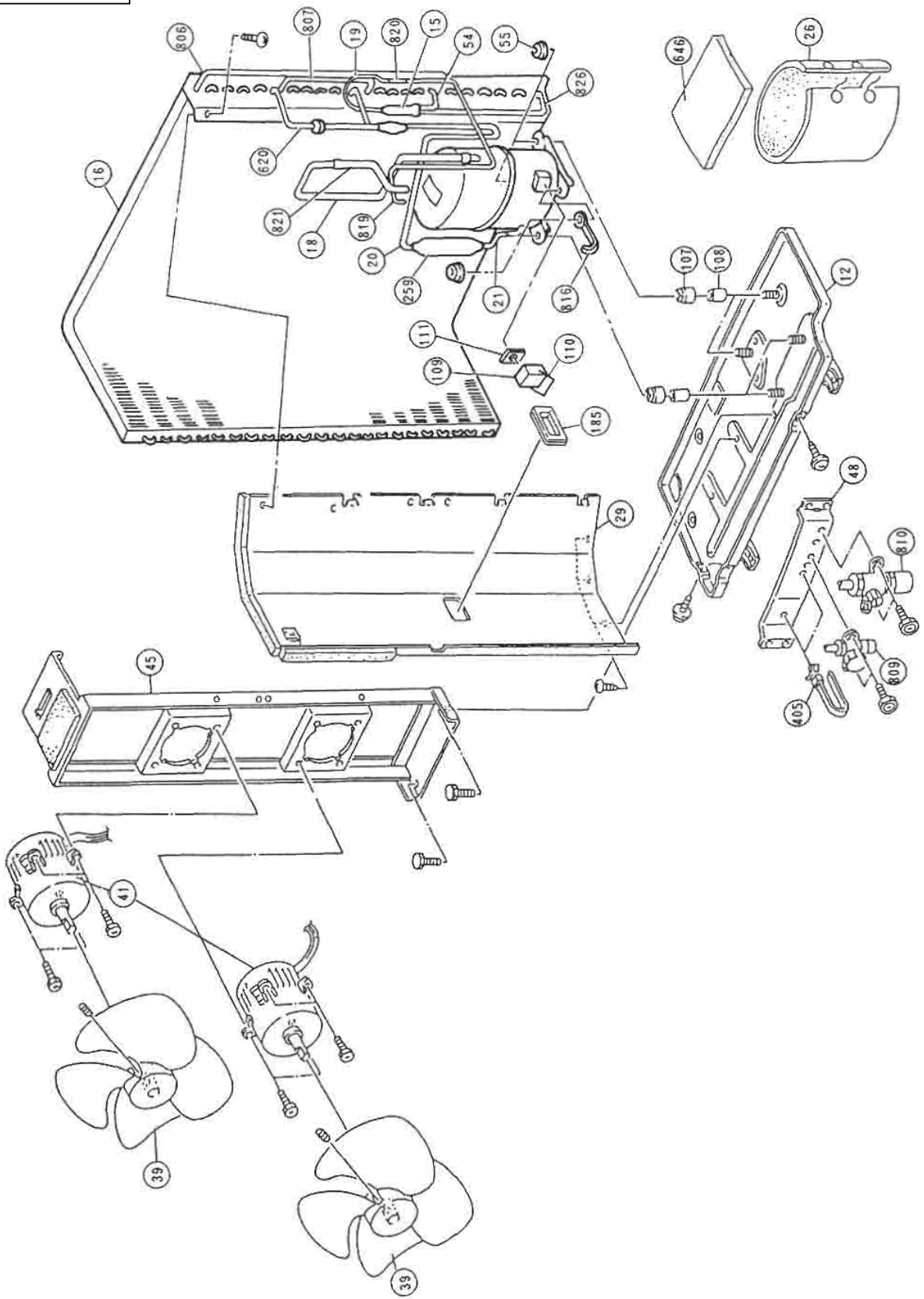

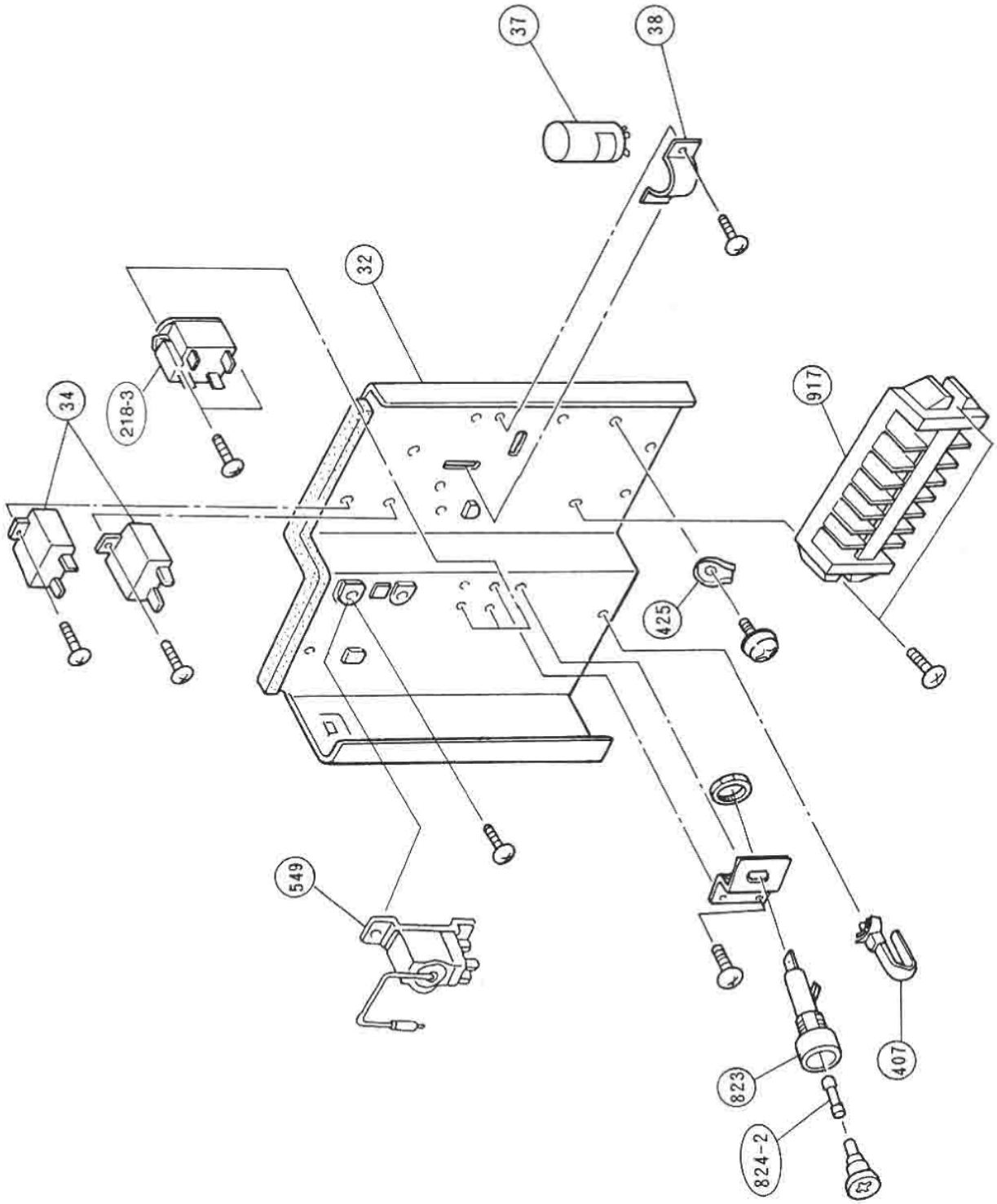

Models: MR18C3E-A  
MR18Y3E-A  
MR24C3E-A  
MR24Y3E-A

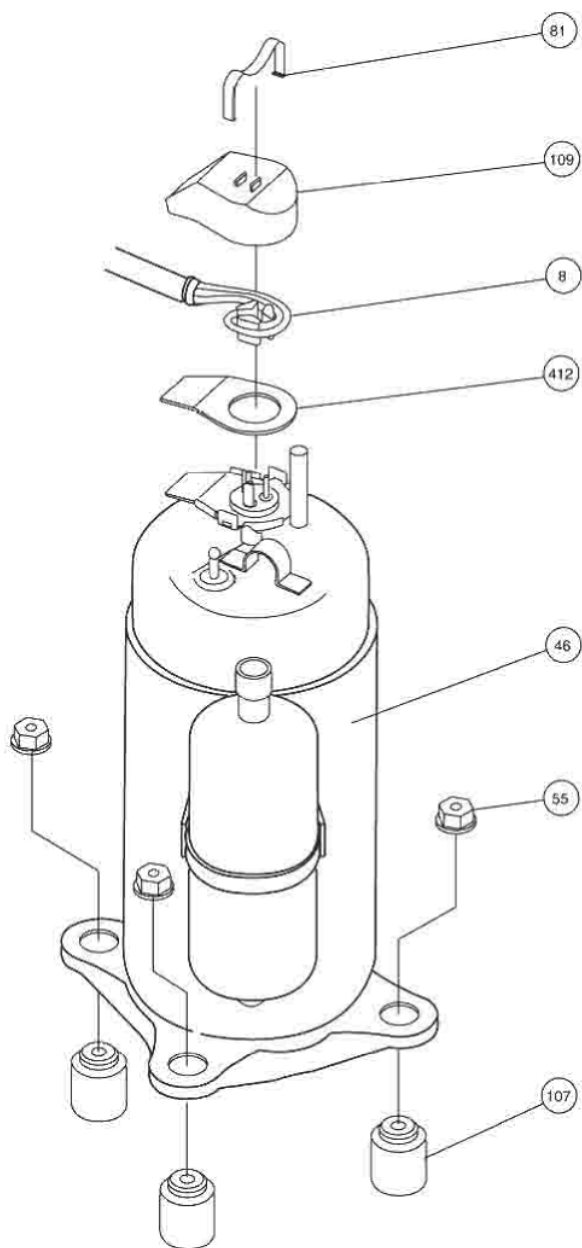

Models: MR18C3E-A  
MR18Y3E-A  
MR24C3E-A  
MR24Y3E-A

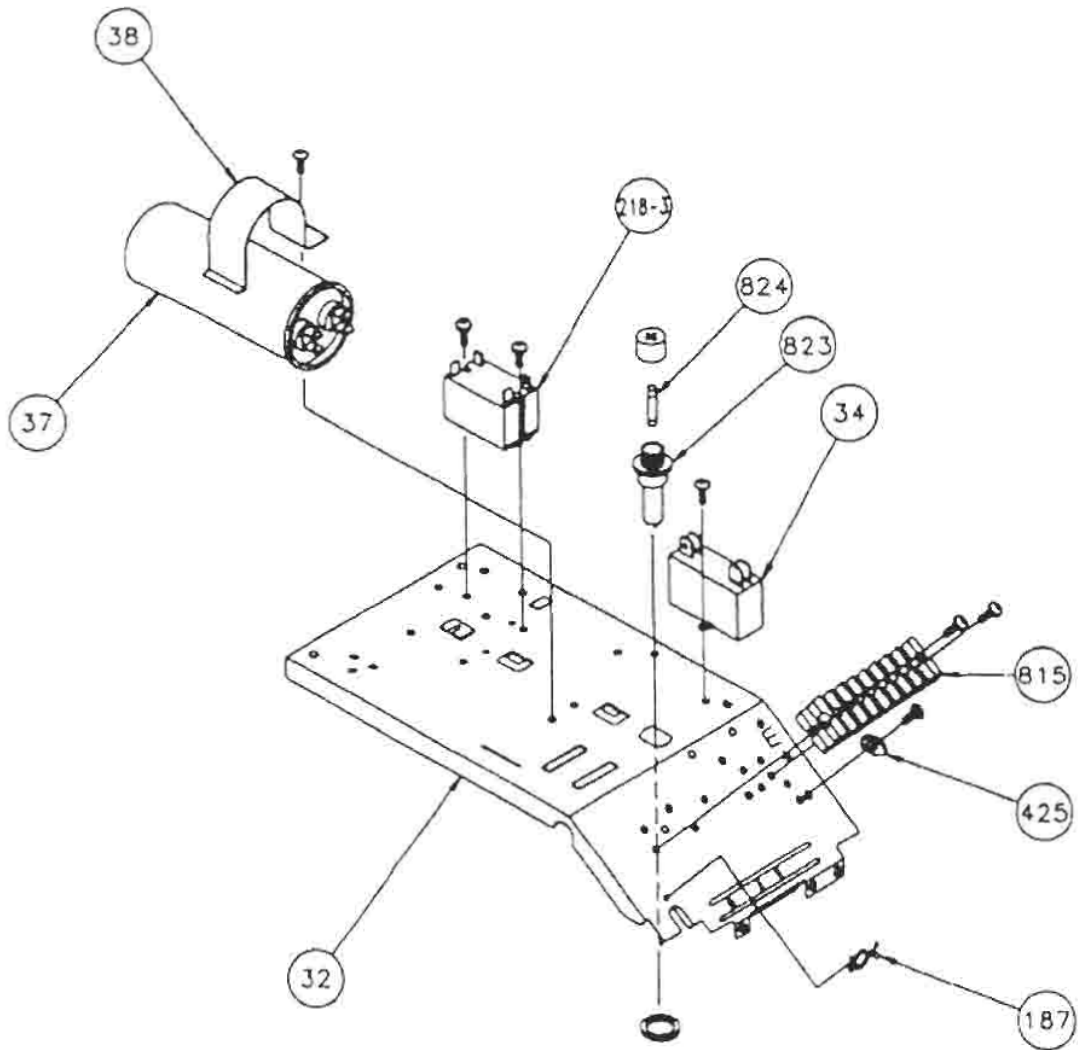

# P A R T S L I S T

MW18C3E  
MW18Y3E  
MW24C3E  
MW24Y3E  
MW30C3E

**INDOOR UNIT**

When you order parts, please make a photocopy of this page  
and fill the number of the parts in the "Order" Column.

Ref. No.	Description	Part No.					Ord. Q'ty
		MW18C3E	MW18Y3E	MW24C3E	MW24Y3E	MW30C3E	
34	Capacitor(Fan Motor)	67210022	67210022	67210022	67210022	67210022	
63	Panel(Front) Total Assy	67210014	67210014	67210014	67210014	67210014	
69	Louver	67120007	67120007	67120007	67120007	67120007	
91	Hinge Plate	67220079	67220079	67220079	67220079	67220079	
93	Air Filter	67210003	67210003	67210003	67210003	67210003	
108	Base	67210011	67210011	67210011	67210011	67210011	
109	Casing Assy	67210015	67210015	67210015	67210015	67210015	
127	Drain Hose Assembly	67210017	67210017	67210017	67210017	67210017	
146	Evaporator Assy	67220074	67220074	67220074	67220074	67220074	
164	Fan Motor Assy-IN	67220076	67220076	67220076	67220076	67220076	
210	Main Relay	67210001	67210001	67210001	67210001	67210001	
234	Thermistor Assy-Room	67210026	67210026	67210026	67210026	67210026	
235	Thermistor Assy-Pipe	67210027	67210027	67210027	67210027	67210027	
236	Controller PCB Assy	67220068	67220070	67220068	67220069	67210031	
240	Remote Control Unit	67210018	67220081	67210018	67220081	67220018	
320	Flap(Upper)-G	67220078	67220078	67220078	67220078	67220078	
325	Cross Flow Fan-R Assy	67210004	67210004	67210004	67210004	67210004	
326	Crossflow Fan – L Assy	67210005	67210005	67210005	67210005	67210005	
385	Indicator PCB Assy	67210025	67210025	67210025	67210025	67210025	
401	Bracket, Panel	67220048	67220048	67220048	67220048	67220048	
407-2	Louver Rod	67210006	67210006	67210006	67210006	67210006	
407-3	Louver Stopper	67210008	67210008	67210008	67210008	67210008	
408	Louver Link	67210009	67210009	67210009	67210009	67210009	
679	Cover(Power)	67210057	67210057	67210057	67210057	67210057	
743	Remote Control Unit Holder	67210019	67210019	67210019	67210019	67210019	
767-1	Bottom Cover-A	67220046	67220046	67220046	67220046	67220046	
767-2	Bottom Cover-B	67220047	67220047	67220047	67220047	67220047	
778	Hook(Grille)-R	67210013	67210013	67210013	67210013	67210013	
777	Hook(Grille)-L	67210012	67210012	67210012	67210012	67210012	
815	Terminal-6P	67210002	67210002	67210002	67210002	67210002	
875	Filter PCB Assy	67210029	67210029	67210029	67210029	67210029	
876-1	Step Motor-H	67220084	67220084	67220084	67220084	67220084	
876-2	Step Motor-V	67220085	67220085	67220085	67220085	67220085	
963	Fan Guard	67210010	67210010	67210010	67210010	67210010	
962	Fan Guard	67210010	67210010	67210010	67210010	67210010	

# P A R T S L I S T

MR18C3E  
MR18Y3E  
MR24C3E  
MR24Y3E

## OUTDOOR UNITS EQUIPPED WITH RECIPROCATING COMPRESSOR

When you order parts, please make a photocopy of this page and fill the number of the parts in the "Order" Column.

Ref. No.	Description	Part No.				Ord. Q'ty
		MR18C3E	MR18Y3E	MR24C3E	MR24Y3E	
2	Fan Cover	67220075	67220075	67220075	67220075	
4	Emblem-Rear "FRIEDRICH"	67210052	67210052	67210052	67210052	
6	Cabinet-C, Painted	67210033	67210033	67210033	67210033	
7	Panel (Top), Painted Metal	67220080	67220080	67220080	67220080	
9	Cabinet-B, Painted	67220028	67220028	67220028	67220028	
12	Base Assy. Painted	67220032	67220032	67220032	67220032	
13	3-Way Valve Assy.	67220038	67220038	67220038	67220038	
14	2-Way Valve Assy.	67220039	67220039	67220039	67220039	
15	Dryer	67220042	67220042	67220042	67220042	
16	Condenser Assy.	67220064	67220064	67220064	67220064	
19	Capillary Tube	67220052	----	67220052	----	
19-3	Capillary Tube-C	----	----	----	67220057	
19-2	Capillary Tube-B	----	67220056	----	67220055	
26	Compressor Blanket	67220034	67220034	67220034	67220034	
34	Capacitor(Fan Motor)	67206200	67206200	67206200	67206200	
37	Running Capacitor	67220037	67220037	67220082	67200082	
39	Propeller Fan Assy.	67210034	67210034	67210034	67210034	
41	Outdoor Fan Motor Assy.	67220077	67220077	67220077	67220077	
46	Compressor Assy.	67220063	67220063	67220063	67220063	
218-3	Power Relay	67210044	67210044	67210044	67210044	
272	Strainer	----	67220087	----	67220086	
343	Solenoid Coil	----	67220083	----	67220083	
344	4-Way Valve	----	67220090	----	67220090	
519	Check Valve Assy.	----	67220061	----	67220060	
646	Compressor Blanket (Top)	67210055	67210055	67210055	67210055	
717	Center Plate	67220041	67220041	67220041	67220041	
815	Terminal-8P	67220088	67220088	67220088	67220088	
824	Fuse	67220025	67220025	67220025	67220025	

# P A R T S L I S T

MR18C3E-A  
MR18Y3E-A  
MR24C3E-A  
MR24Y3E-A

## OUTDOOR UNITS EQUIPPED WITH ROTARY COMPRESSOR

When you order parts, please make a photocopy of this page and fill the number of the parts in the "Order" Column.

Ref. No.	Description	Part No.				Ord. Qty
		MR18C3E-A	MR18Y3E-A	MR24C3E-A	MR24Y3E-A	
2	Fan Cover	67220075	67220075	67220075	67220075	
4	Emblem-Rear "FRIEDRICH"	67210052	67210052	67210052	67210052	
5	Cabinet-A Painted	67220029	67220029	67220029	67220029	
6	Cabinet-C, Painted	67220033	67220033	67220033	67220033	
7	Electrical Access Panel, Painted	67220080	67220080	67220080	67220080	
9	Cabinet-B, Painted	67220028	67220028	67220028	67220028	
12	Base Assy. Painted	67210151	67210151	67210151	67210151	
13	3-Way Valve Assy.	67220138	67220138	67220138	67220138	
14	2-Way Valve Assy.	67220139	67220139	67220139	67220139	
15	Dryer	67200449	67200449	67200449	67200449	
16	Condenser Assy.	67220183	67220184	67220185	67220191	
19	Capillary Tube-A	67220052	67220054	67220052	67220057	
19-2	Capillary Tube-B	----	67220056	----	67220055	
19-3	Capillary Tube-C		----		67220053	
26	Compressor Blanket	67210155	67210155	67210155	67210155	
34	Capacitor(Fan Motor)	67220186	67220186	67220186	67220186	
37	Running Capacitor	67220037	67220037	67220082	67220082	
39	Propeller Fan Assy.	67210034	67210034	67210034	67210034	
41	Outdoor Fan Motor Assy.	67220077	67220077	67220077	67220077	
46	Compressor Assy.	67210113	67210113	67210154	67210154	
218-3	Power Relay	67210347	67210347	67210347	67210347	
272	Strainer	----	67220150	----	67220086	
343	Solenoid Coil	----	67220083	----	67220083	
344	4-Way Valve	----	67220090	----	67220091	
519	Check Valve Assy.	----	67220061	----	67220060	
646	Compressor Blanket - Top	67210055	67210055	67210055	67210055	
717	Center Plate	67220041	67220041	67220041	67220041	
815	Terminal-8P	67220088	67220088	67220088	67220088	
824	Fuse	67220025	67220025	67220025	67220025	
81	Strap	67210120	67210120	67210120	67210120	
109	Terminal Cover	67210116	67210116	67210116	67210116	
412	Terminal Cover Gasket	67210115	67210115	67210115	67210115	
N/S	Crankcase Heater	67220188	67220188	67220188	67220188	
N/S	Crankcase Heater Relay	67210156	67210156	67210156	67210156	

# P A R T S L I S T

Reference No.	MR30C3E	
	Description	Part No.
2	Fan Cover	67210040
4	Emblem-Rear "FRIEDRICH"	-----
6	Cabinet-C, Painted	67210039
7	Panel (Top), Painted Metal	-----
9	Cabinet-B, Painted	67210038
12	Base Assy. Painted	67210036
13	3-Way Valve Assy.	-----
14	2-Way Valve Assy.	-----
15	Dryer	67210033
16	Condenser Assy.	67210035
19	Capillary Tube	67230047
519	Restrictor Valve (Cap Tub)	-----
519	Restrictor Valve (Cap Tub)	-----
26	Compressor Cover	-----
30	Blower Cover	67210040
34	Capacitor(Fan Motor)	67230046
37	Running Capacitor	67230047
39	Propeller Fan Assy.	67210034
41	Fan Motor Assy.-OUT	67210053
46	Compressor Assy.	67210050
218-3	Power Relay	67210044
272	Strainer	-----
343	Solenoid Coil	-----
344	4-Way Valve	-----
519	Check Valve Assy.	-----
549	Thermostat – Outdoor	67210054
646	Compressor Cover-B	-----
717	Center Plate	-----
734	Cabinet Tip Plate	67210042
803	Cabinet D Painted	67210048
805	Blower Cover Corner	67210041
809	Ball Valve A	67210003
810	Ball Valve B	67210004
815	Terminal-8P	67210032
824	Fuse	
Q1	Xstr 2SC4236	67220089
T1	Transformer ETS28A118AH	67210028
BZ1	Buzzer	67220050
13m 3 (6,&	Relay JQ1-12V	67210023
SSR-1	Relay G3M-202P-US	67210024
F101	Fuse MT3 3A-250V	67210000

