

This Owner's Manual is provided and hosted by [Appliance Factory Parts](http://www.appliancefactoryparts.com).



FRIEDRICH MR36TQY3F Owner's Manual

[Shop genuine replacement parts for FRIEDRICH
MR36TQY3F](#)

Model : MR36TQY3F

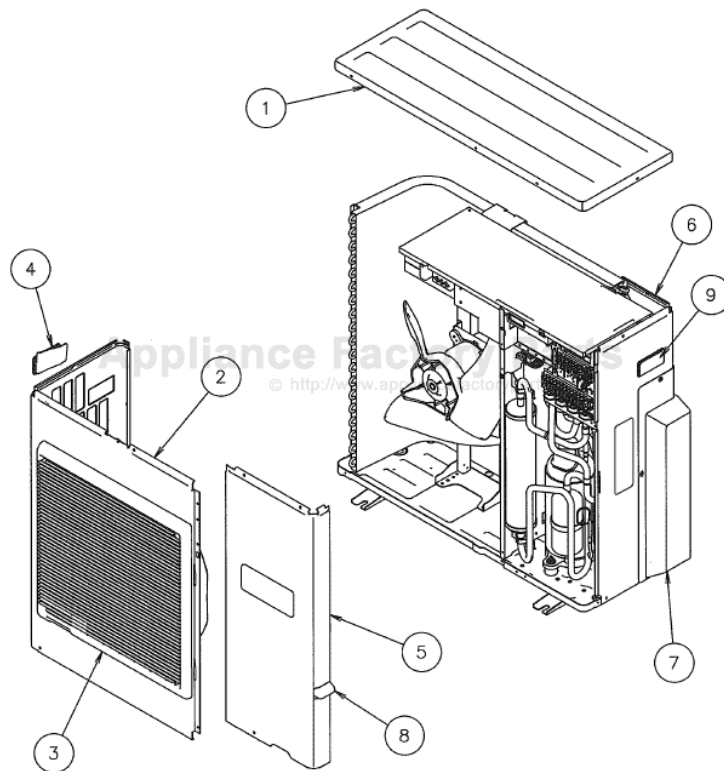

[Find Your FRIEDRICH Air Conditioner Parts - Select From 1575 Models](#)

----- Manual continues below -----



**INVERTER MULTI
AIR CONDITIONER**

WALL MOUNTED type

SERVICE MANUAL

Models

Indoor unit

MW09Y3FM

MW12Y3FM

MW18Y3FM

Outdoor unit

MR36TQY3F

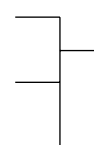

CONTENTS

SPECIFICATIONS	1
OUTLINE AND DIMENSIONS	3
REFRIGERANT SYSTEM DIAGRAM	5
CIRCUIT DIAGRAM	6
INDOOR PCB CIRCUIT DIAGRAM	9
OUTDOOR PCB CIRCUIT DIAGRAM	12
ERROR CONTENTS	15
DISASSEMBLY ILLUSTRATION	17
PARTS LIST	23
STANDARD ACCESSORIES	25

SPECIFICATIONS (INDOOR UNIT)

ELECTRICAL DATA

TYPE	COOLING & HEATING		
MODEL NAME	MW09Y3FM	MW12Y3FM	MW18Y3FM
POWER SOURCE	1 - 230 / (208) V 60Hz		
COOLING CAPACITY (Rated / Max)	2.7 kW / 3.3 kW 9,500 / 11,300 BTU/h	3.5 kW / 4.0 kW 12,000 / 13,600 BTU/h	5.2 kW / 5.55 kW 17,800 / 19,000 BTU/h
HEATING CAPACITY (Rated / Max)	3.2 kW / 3.8 kW 11,000 / 13,000 BTU/h	4.1 kW / 4.5 kW 14,000 / 15,400 BTU/h	6.0 kW / 6.7 kW 20,500 / 23,000 BTU/h
MOISTURE REMOVAL	1.7 Pts/hr (0.8 L/hr)	2.0 Pts/hr (1.1 L/hr)	4.9 Pts/hr (2.3 L/hr)
AIR CIRCULATION-High	324 cfm (550 m ³ /hr)	377 cfm (640 m ³ /hr)	388 cfm (660 m ³ /hr)

Power source of specification : 230V

FAN MOTOR

DISCRIMINATION		MFD-34ROM		
FAN SPEED (Cool / Heat)	High	1,200 / 1,200 r.p.m.	1,380 / 1,380 r.p.m.	1,480 / 1,480 r.p.m.
	Middle	1,070 / 1,070 r.p.m.	1,230 / 1,230 r.p.m.	1,380 / 1,380 r.p.m.
	Low	900 / 970 r.p.m.	1,050 / 1,110 r.p.m.	1,200 / 1,200 r.p.m.
	Quiet	800 / 850 r.p.m.	900 / 960 r.p.m.	1,060 / 1,060 r.p.m.

NOISE LEVEL

NOISE LEVEL (Cool / Heat)	High	38 dB / 38 dB	43 dB / 43 dB	45 dB / 45 dB
	Middle	34 dB / 34 dB	40 dB / 40 dB	43 dB / 43 dB
	Low	28 dB / 30 dB	33 dB / 34 dB	39 dB / 39 dB
	Quiet	25 dB / 26 dB	28 dB / 30 dB	34 dB / 34 dB

PIPING

MAXIMUM LENGTH		82 ft. (25 m)	
MAXIMUM HEIGHT		49 ft. (15 m)	
DIAMETER SIZE	Liquid	1/4 inch (6.35 mm)	
	Gas	3/8 inch (9.52 mm)	1/2 inch (12.7 mm)

MEASUREMENTS

DIMENSIONS	H x W x D	10-13/16 x 31-1/8 x 8-7/16 inch (275 x 790 x 215 mm)
WEIGHT	Net / Gross	18 lbs. / 23 lbs. (8.5 kg / 10.5 kg)

SPECIFICATIONS (OUTDOOR UNIT)

ELECTRICAL DATA

TYPE		4 room multi inverter
MODEL NAME		MR36TQY3F
POWER SUPPLY		230 / 208 V
FREQUENCY		60 Hz
AIR CIRCULATION - High	Cooling	2119 cfm (3,600 m ³ /hr)
	Heating	2237 cfm (3,800 m ³ /hr)
NOISE LEVEL	Cooling	51 dB
	Heating	53 dB

COMPRESSOR

TYPE		Hermetic type, Inverter, 4 poles, 3-phase, DC motor, Twin Rotary
DISCRIMINATION		TNB220FPBM9
REFRIGERANT	R410A	7 lb 7/8 oz (3,200 g)

FAN MOTOR

DISCRIMINATION		MFE-45ROM
HIGH-SPEED	Cooling	850 r.p.m.
	Heating	900 r.p.m.

REFRIGERANT CHARGE (R410A)

Total Pipe Length	164 ft (50.0 m)	-- (Chargeless)
ADDITIONAL CHARGE	197 ft (60.0 m)	8-13/16 oz (250 g)
	230 ft (70.0 m)	1 lb 1-5/8 oz (500 g)
ADDITIONAL CHARGE		9/32 oz/ft (25 g/m)
CHARGELESS		164 ft (50 m)
MAX PIPE LENGTH (each unit)		82 ft (25 m)
MAX PIPE LENGTH (total)		229 ft (70 m)
MAX ELEVATION (between indoor units)		49 ft (15 m)
MAX ELEVATION (between indoor and outdoor units)		49 ft (15 m)
MIN. PIPE LENGTH (each unit)		16 ft (5 m)

MEASUREMENT

DIMENSIONS	H x W x D	32-7/8 x 35-7/16 x 13 inch (835 x 900 x 330 mm)
WEIGHT	Net / Gross	149 lb / 167 lb (68 kg / 76 kg)

SPECIFICATIONS (COMBINATION)

ELECTRICAL DATA (230 V)

COMBINATION		MW09Y3FM x 3	MW12Y3FM + MW09Y3FM x 2	MW12Y3FM x 2 + MW09Y3FM
COOLING CAPACITY	Rated	8.1 kW 27,600 BTU/h	8.9 kW 30,400 BTU/h	9.7 kW 33,000 BTU/h
	Max	9.7 kW 33,000 BTU/h	9.9 kW 33,900 BTU/h	10.1 kW 34,600 BTU/h
HEATING CAPACITY	Rated	9.7 kW 33,000 BTU/h	10.4 kW 35,500 BTU/h	10.8 kW 37,000 BTU/h
	Max	11.8 kW 40,200 BTU/h	11.7 kW 40,000 BTU/h	12.0 kW 41,000 BTU/h
INPUT POWER (Cooling)	Rated	2.75 kW	3.30 kW	3.75 kW
	Max	3.74 kW	4.10 kW	4.10 kW
INPUT POWER (Heating)	Rated	2.96 kW	3.10 kW	3.30 kW
	Max	3.80 kW	4.10 kW	4.10 kW
CURRENT (Cooling)	Rated	12.0 A	14.4 A	16.4 A
	Max	16.4 A	18.0 A	18.0 A
CURRENT (Heating)	Rated	13.0 A	13.5 A	14.5 A
	Max	16.6 A	18.0 A	18.0 A

ELECTRICAL DATA (230 V)

COMBINATION		MW12Y3FM x 3	MW18Y3FM + MW09Y3FM x 2	MW09Y3FM x 4
COOLING CAPACITY	Rated	10.3 kW 35,100 BTU/h	10.3 kW 35,200 BTU/h	10.3 kW 35,200 BTU/h
	Max	10.5 kW 35,700 BTU/h	10.5 kW 36,000 BTU/h	10.5 kW 36,000 BTU/h
HEATING CAPACITY	Rated	10.9 kW 37,200 BTU/h	10.9 kW 37,200 BTU/h	10.7 kW 36,500 BTU/h
	Max	12.5 kW 42,600 BTU/h	12.3 kW 42,000 BTU/h	12.3 kW 42,000 BTU/h
INPUT POWER (Cooling)	Rated	4.00 kW	4.00 kW	4.00 kW
	Max	4.10 kW	4.10 kW	4.10 kW
INPUT POWER (Heating)	Rated	3.30 kW	3.30 kW	3.00 kW
	Max	3.80 kW	3.80 kW	3.70 kW
CURRENT (Cooling)	Rated	17.5 A	17.5 A	17.5 A
	Max	18.0 A	18.0 A	18.0 A
CURRENT (Heating)	Rated	14.5 A	14.5 A	13.1 A
	Max	16.6 A	16.6 A	16.2 A

OUTLINE AND DIMENSIONS

INDOOR UNIT

Models :

MW09Y3FM

MW12Y3FM

MW18Y3FM

Unit : inch (mm)

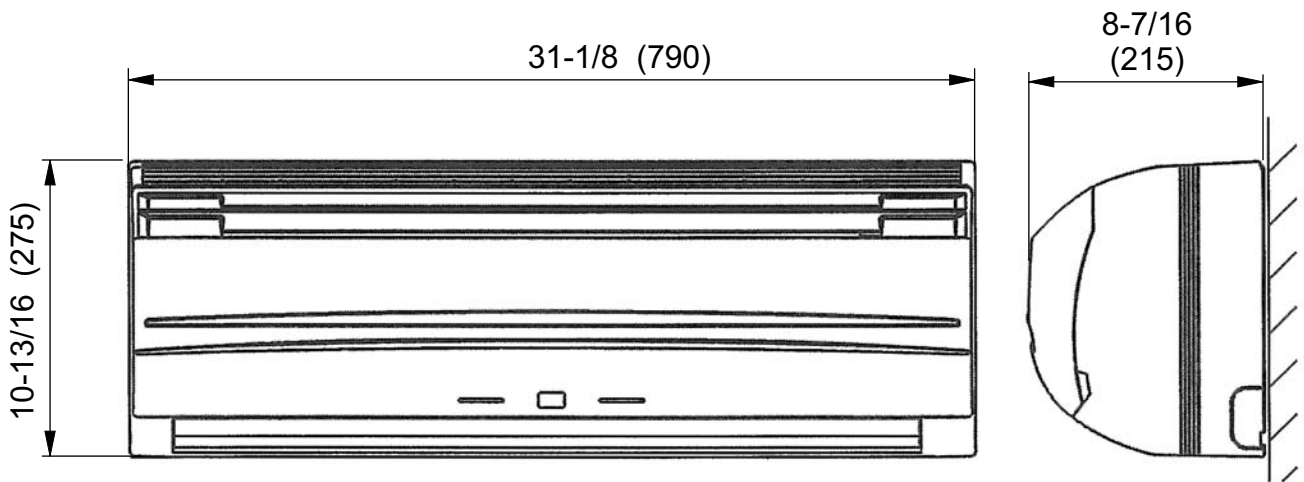

OUTDOOR UNIT

Model : MR36TQY3F

Unit : inch (mm)

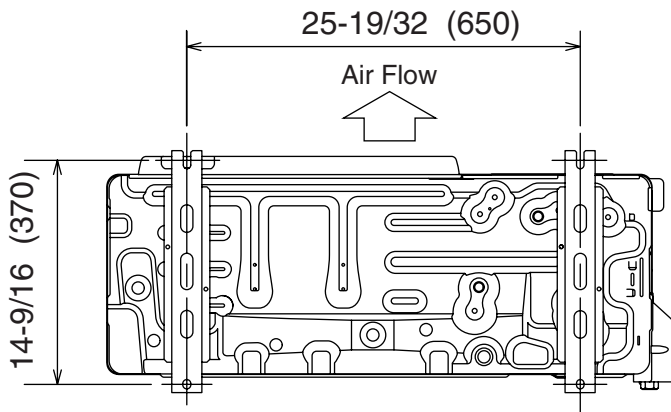
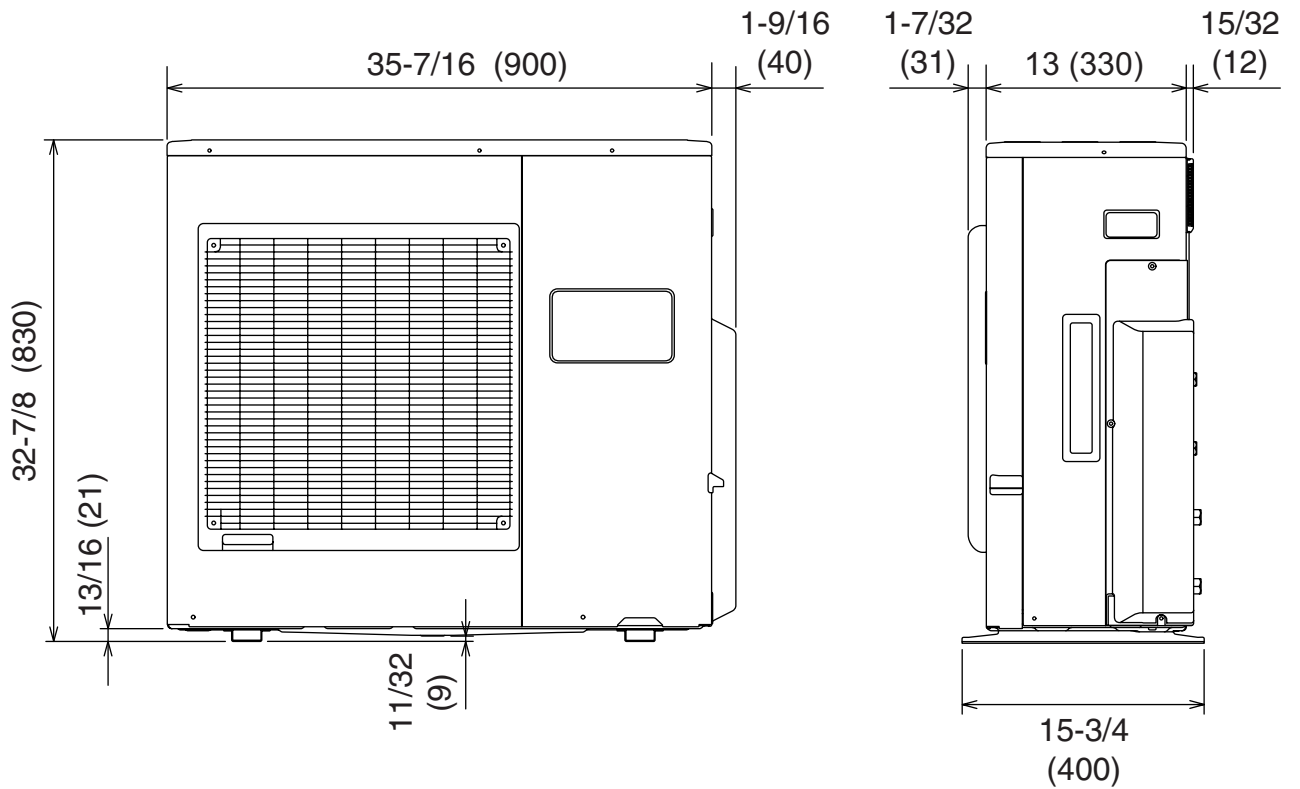
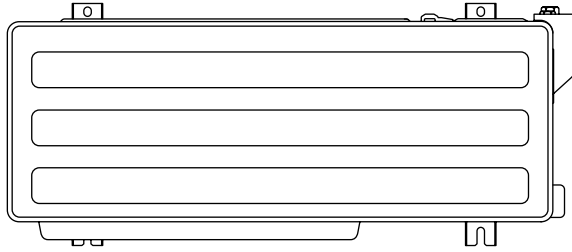

REFRIGERANT SYSTEM DIAGRAM

Outdoor unit

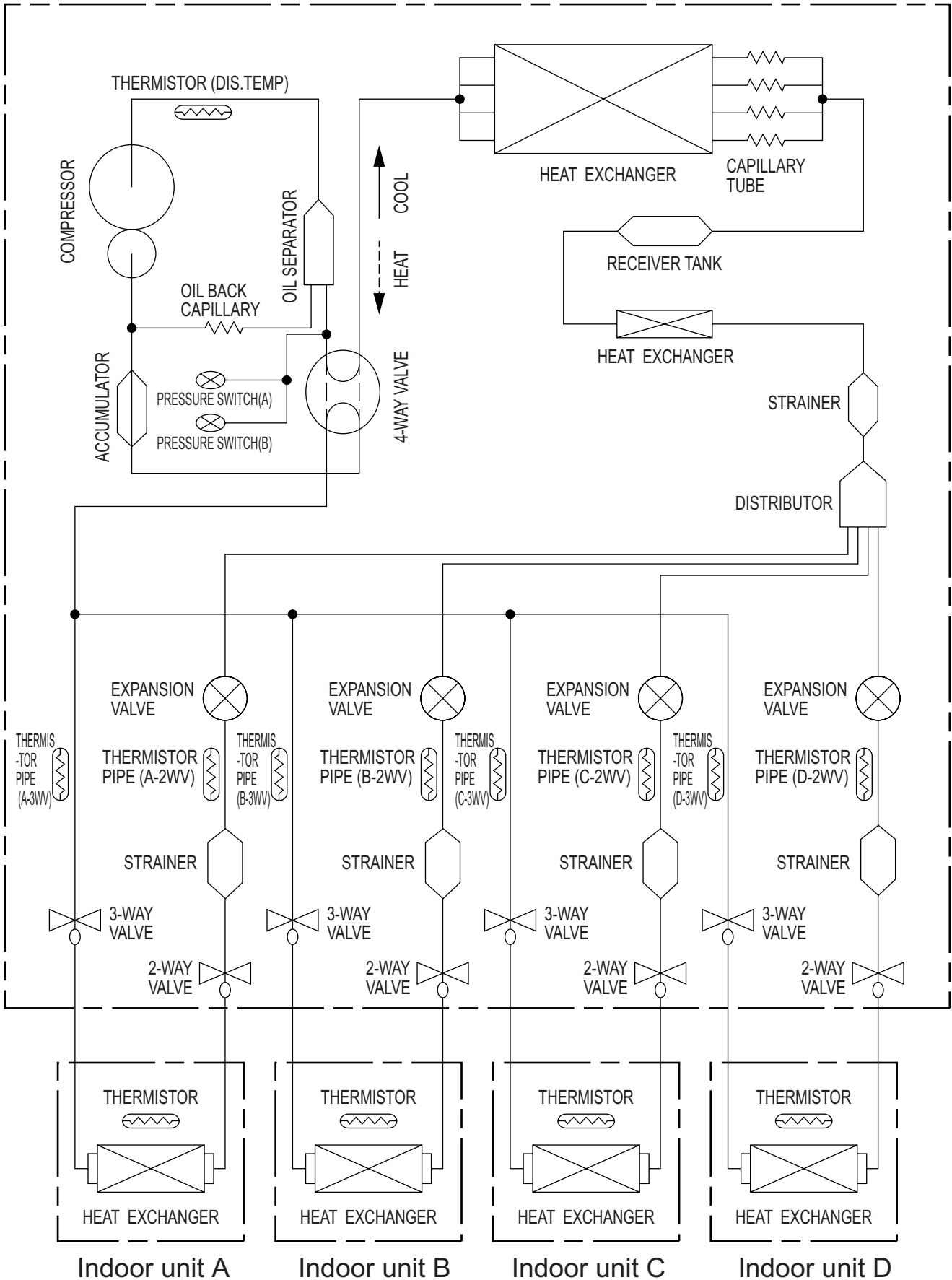

CIRCUIT DIAGRAM

INDOOR UNIT

Models :

MW09Y3FM

MW12Y3FM

MW18Y3FM

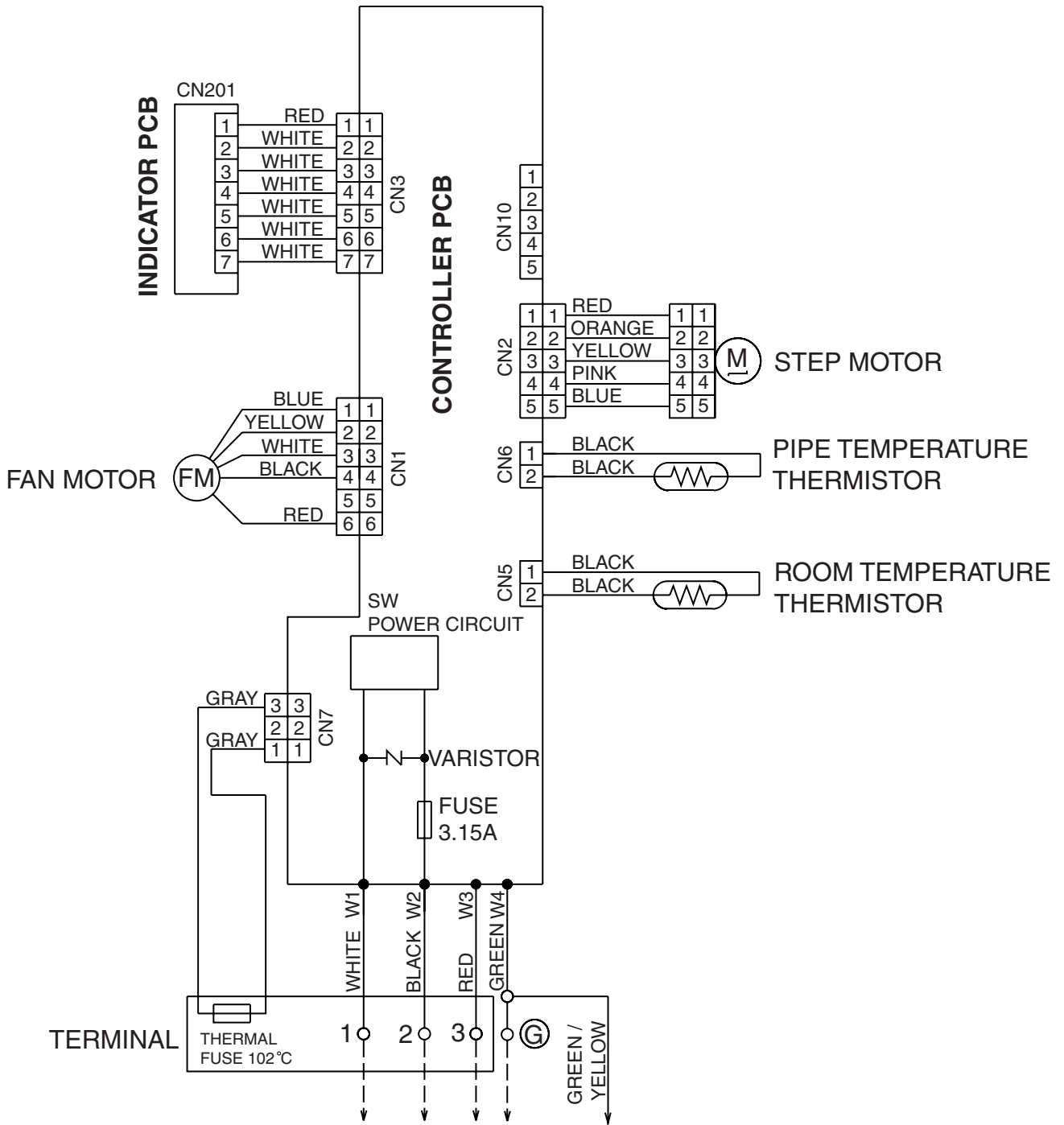

OUTDOOR UNIT

Model : MR36TQY3F

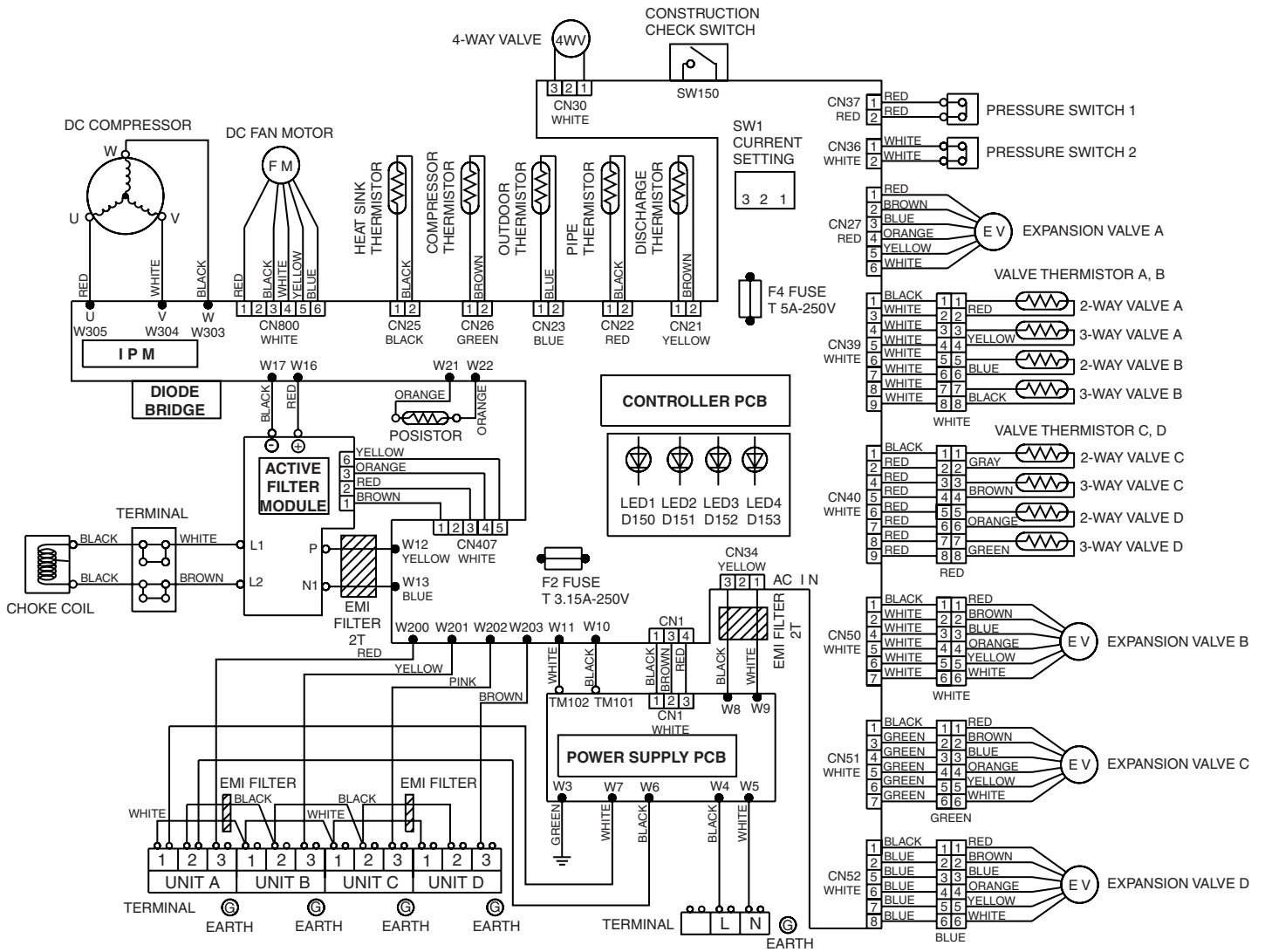

INDOOR PCB CIRCUIT DIAGRAM

Models :
 MW09Y3FM
 MW12Y3FM
 MW18Y3FM

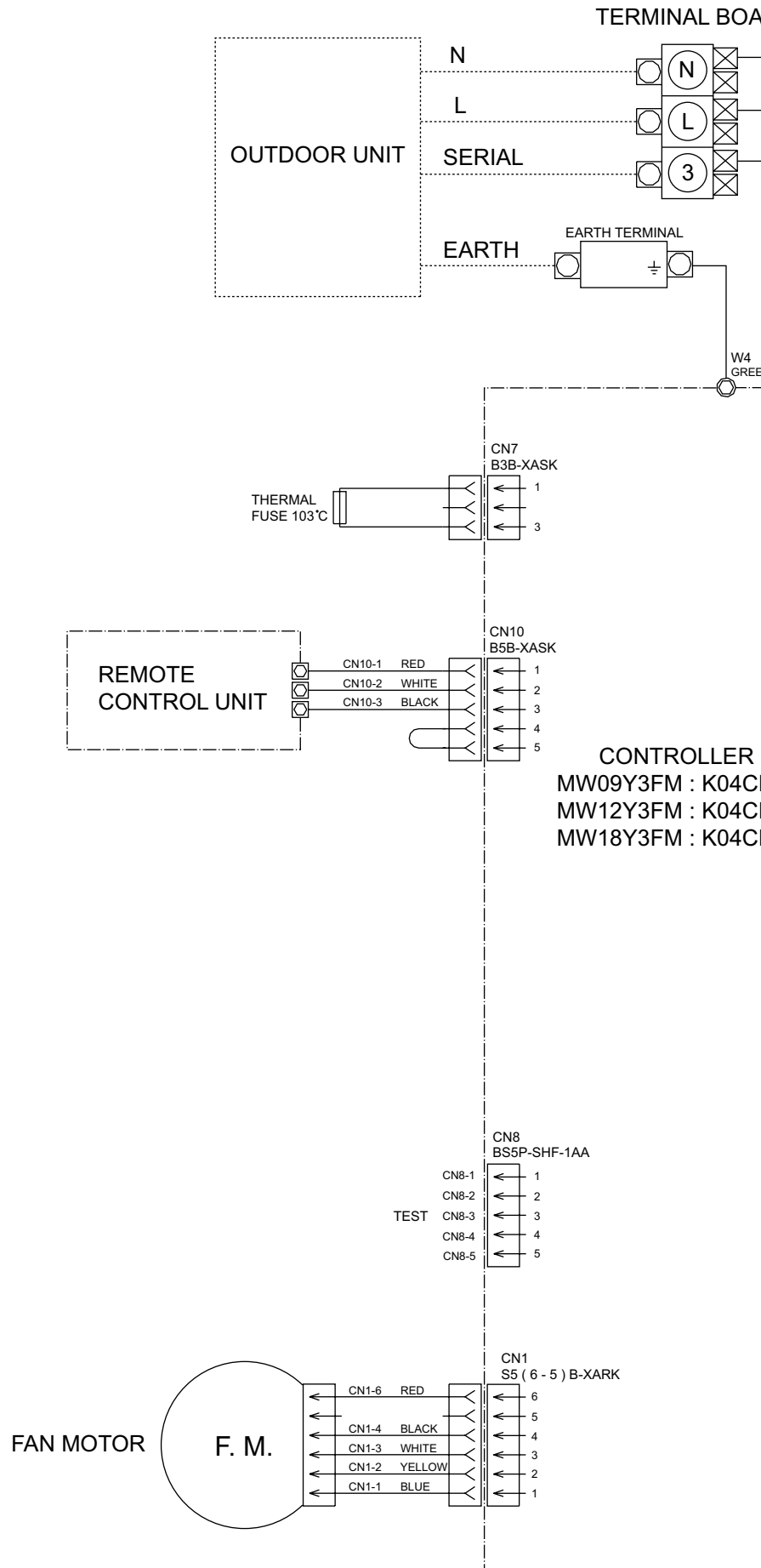

Models :
 MW09Y3FM
 MW12Y3FM
 MW18Y3FM

CONTROLLER
 MW09Y3FM : K04
 MW12Y3FM : K04
 MW18Y3FM : K04

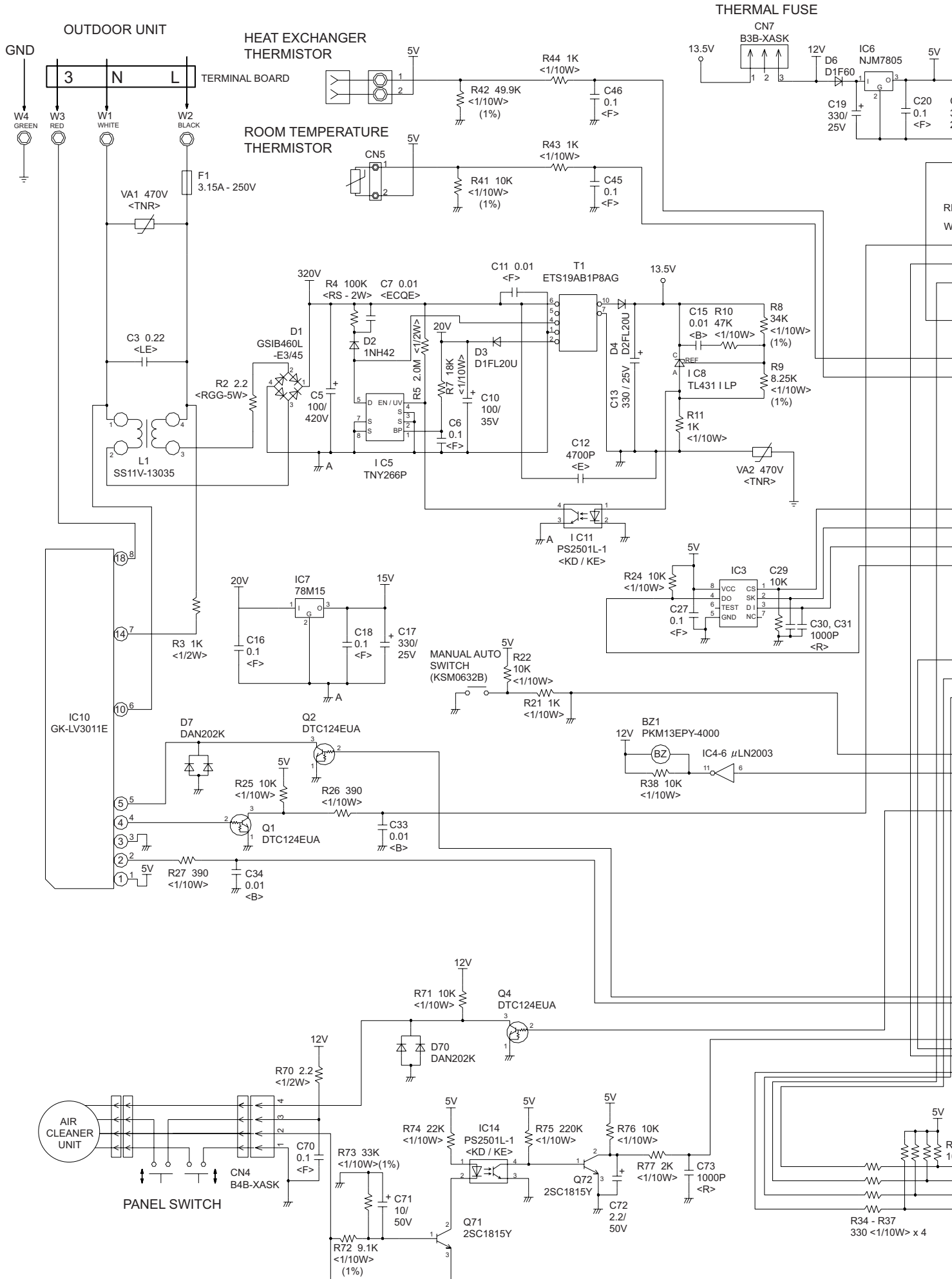

Models :
 MW09Y3FM
 MW12Y3FM
 MW18Y3FM

INDICATOR PCB ASSEMBLY K02CB-0300HSD-D0

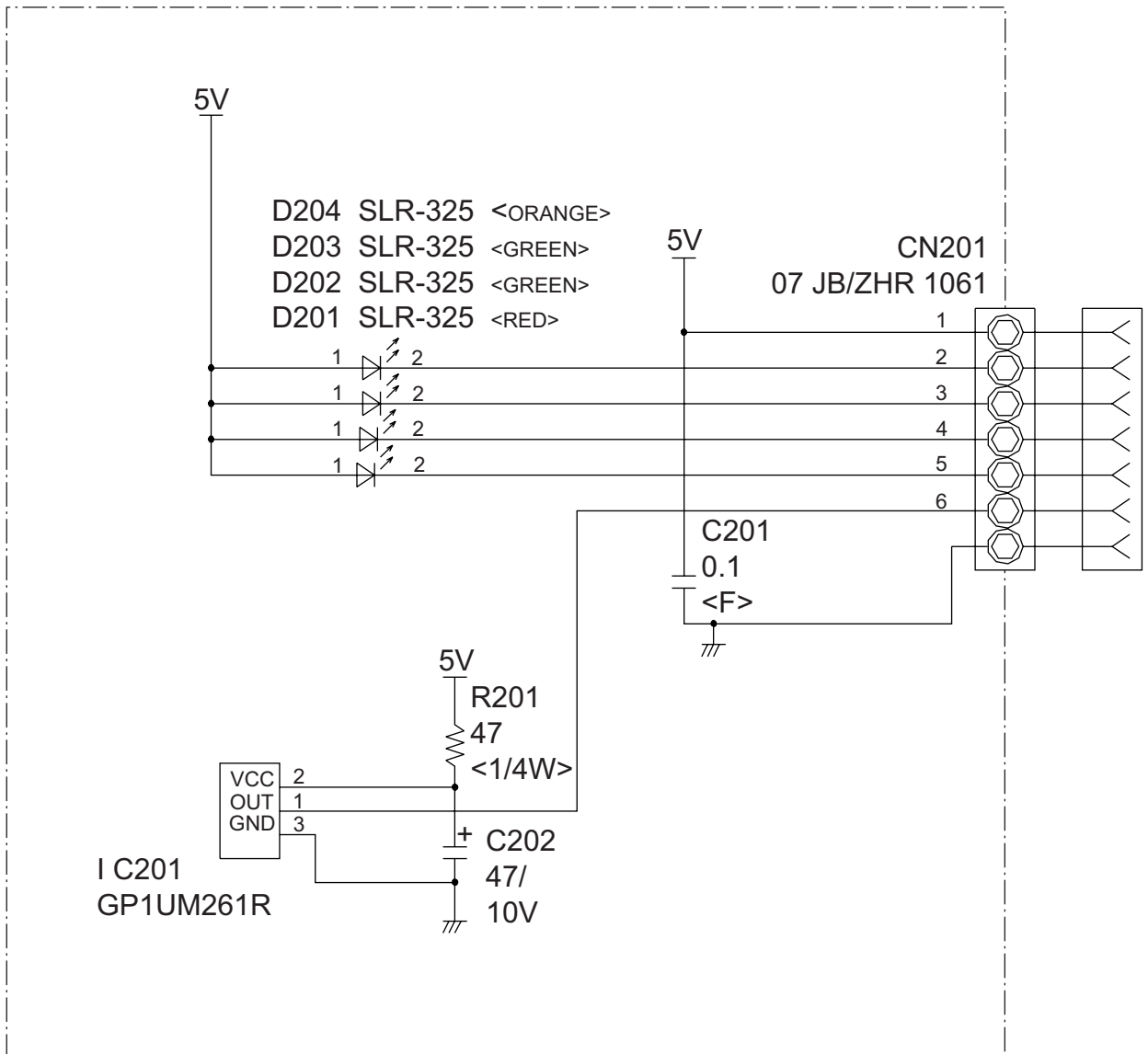

OUTDOOR PCB CIRCUIT DIAGRAM

Model : MR36TQY3F

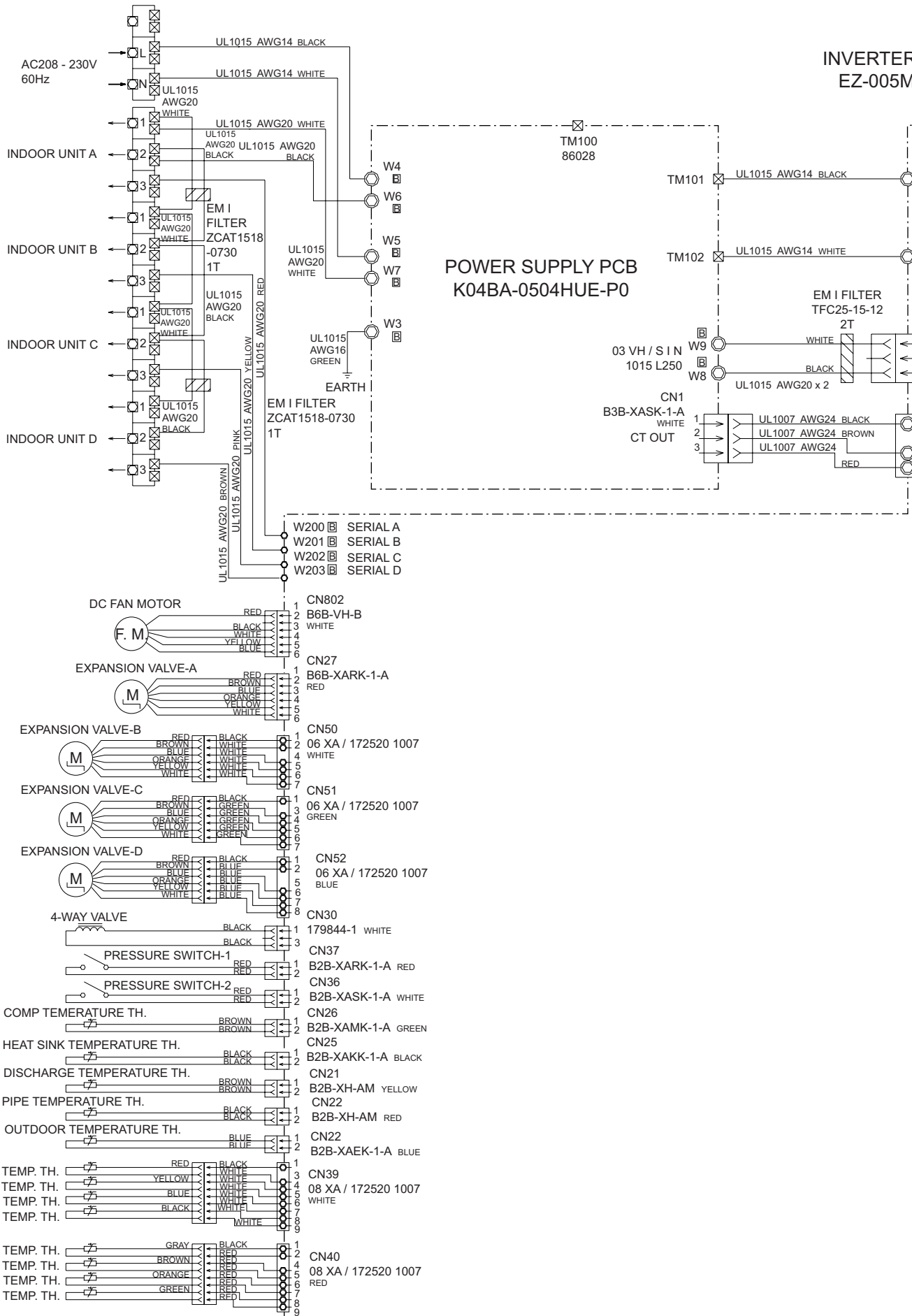

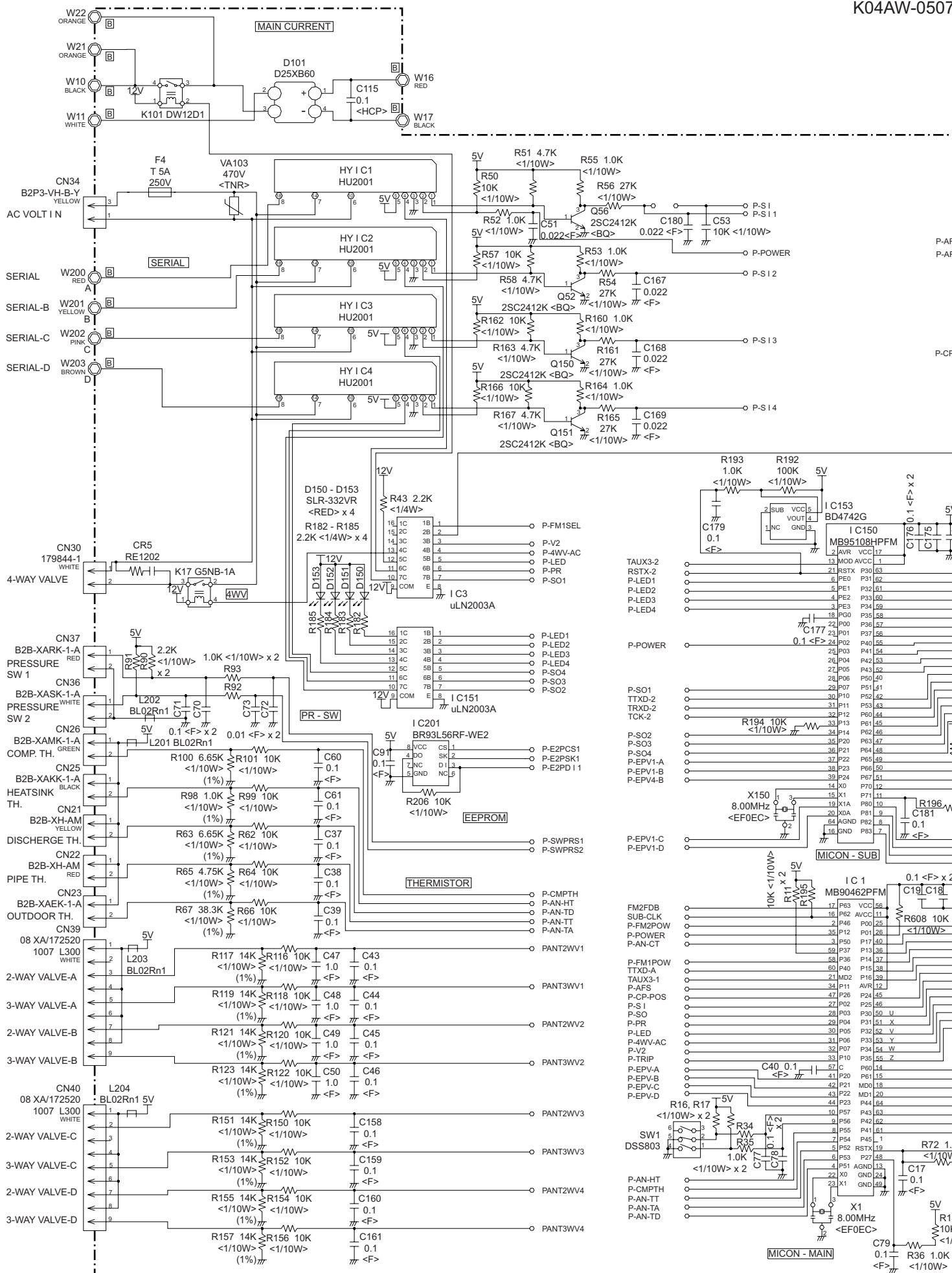

POWER SUPPLY PCB ASSEMBLY
K04BA-0400HUE-P0

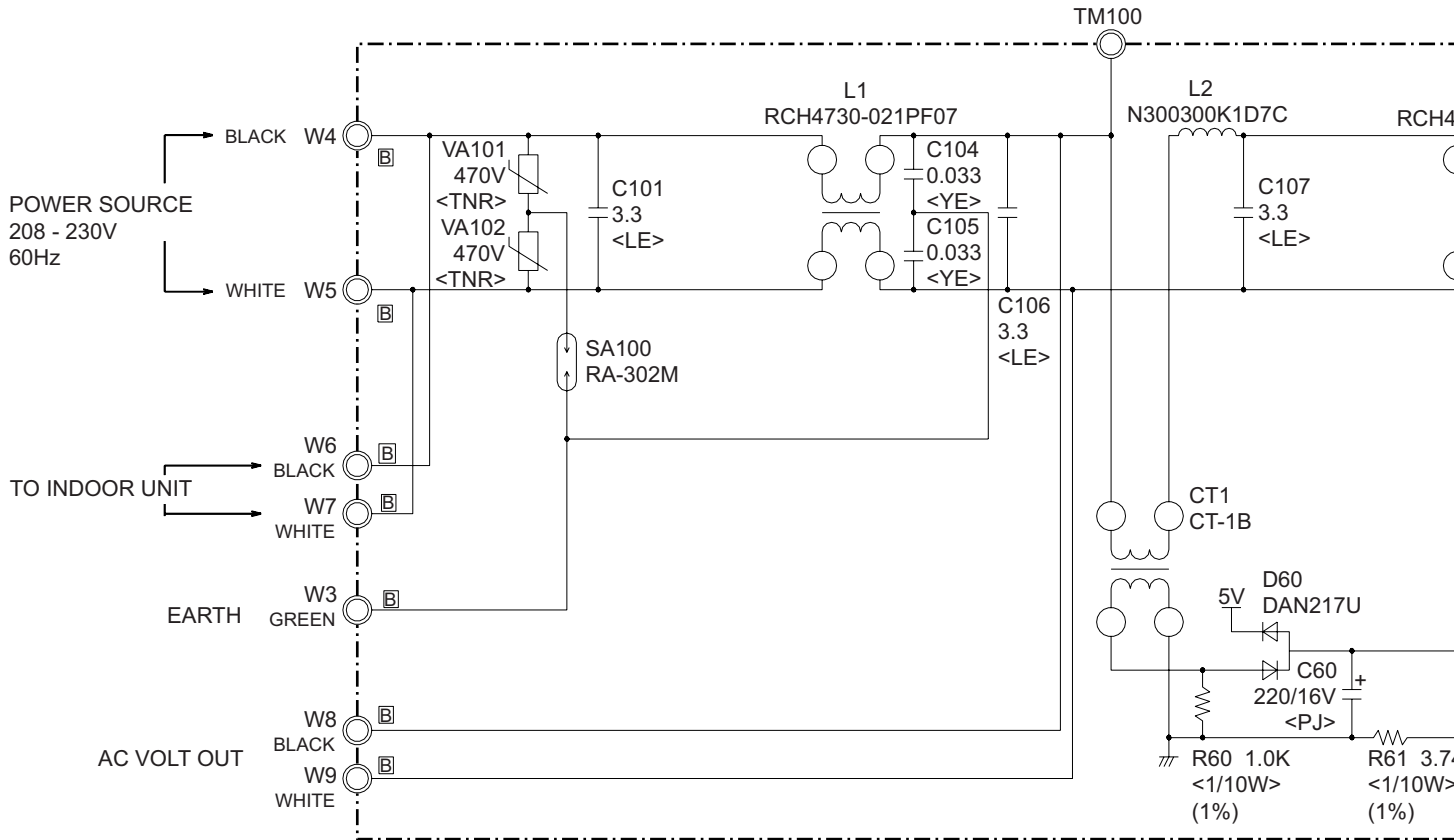

ERROR CONTENTS

INDOOR UNIT

Models :
 MW09Y3FM
 MW12Y3FM
 MW18Y3FM

Error contents		Error display Indoor unit LED			
		OPERATION (Red)	TIMER (Green)	AIR CLEAN or QUIET (Green)	COIL DRY (Orange)
Communication error	Indoor unit - Outdoor unit	off	2 - 5 flashes	off	off
Indoor unit temperature error	Room temp. sensor error	2 flashes	2 flashes	off	off
	Heat exchanger temp. sensor error	2 flashes	3 flashes	off	off
Outdoor unit temperature error	Discharge pipe temp. sensor error	3 flashes	2 flashes	off	off
	Heat exchanger temp. sensor error	3 flashes	3 flashes	off	off
	Outdoor temp. sensor error	3 flashes	4 flashes	off	off
	2 way valve temp. sensor error	3 flashes	off	2 flashes	off
	3 way valve temp. sensor error	3 flashes	off	3 flashes	off
	Heat sink temp. sensor error	3 flashes	7 flashes	off	off
	Compressor temp. sensor error	3 flashes	8 flashes	off	off
Indoor unit control system error	MANUAL AUTO button error	4 flashes	2 flashes	off	off
	50Hz / 60Hz distinguish error	4 flashes	4 flashes	off	off
	Electronic Air clean filter error	4 flashes	7 flashes	off	off
	Electronic Air clean filter error	4 flashes	8 flashes	off	off
Outdoor unit control system error	Current trip error	5 flashes	2 flashes	off	off
	CT error	5 flashes	3 flashes	off	off
	Compressor position error	5 flashes	5 flashes	off	off
	Fan motor error	5 flashes	6 flashes	off	off
	Connected indoor unit error	5 flashes	7 flashes	off	off
	Main CPU - sub CPU communication error	5 flashes	8 flashes	off	off
Indoor unit fan motor error	Fan motor error	6 flashes	2 flashes	off	off
	Fan motor error	6 flashes	3 flashes	off	off
Refrigerant system error	Discharge pipe temp. error	7 flashes	2 flashes	off	off
	High pressure error	7 flashes	3 flashes	off	off
	High pressure switch error	7 flashes	6 flashes	off	off
Added function error	Active filter error	8 flashes	2 - 3 flashes	off	off
Indoor unit connect error	Indoor unit model error	blinking	blinking	blinking	blinking

OUTDOOR UNIT LEDS

	LED 1	LED 2	LED 3	LED 4
Communication error (indoor unit A to outdoor unit)	● 1 time	—	—	—
Communication error (indoor unit B to outdoor unit)	—	● 1 time	—	—
Communication error (indoor unit C to outdoor unit)	—	—	● 1 time	—
Communication error (indoor unit D to outdoor unit)	—	—	—	● 1 time
Discharge pipe temperature sensor	● 2 times	—	—	—
Outdoor heat exchanger temperature sensor	● 3 times	—	—	—
Outdoor temperature sensor	● 4 times	—	—	—
Outdoor 2way valve(A) temperature sensor	● 5 times	—	—	—
Outdoor 2way valve(B) temperature sensor	—	● 5 times	—	—
Outdoor 2way valve(C) temperature sensor	—	—	● 5 times	—
Outdoor 2way valve(D) temperature sensor	—	—	—	● 5 times
Outdoor 3way valve(A) temperature sensor	● 6 times	—	—	—
Outdoor 3way valve(B) temperature sensor	—	● 6 times	—	—
Outdoor 3way valve(C) temperature sensor	—	—	● 6 times	—
Outdoor 3way valve(D) temperature sensor	—	—	—	● 6 times
Compressor temperature sensor	● 7 times	—	—	—
Heatsink temperature sensor	● 8 times	—	—	—
Pressure switch A abnormal	● 9 times	—	—	—
Pressure switch B abnormal	● 10 times	—	—	—
Indoor unit connection capacity error	● 11 times	—	—	—
IPM error	● 12 times	—	—	—
Compressor later location error	● 13 times	—	—	—
Compressor can not start to operate	● 14 times	—	—	—
Outdoor fan (upper) motor error	● 15 times	—	—	—
Outdoor fan (lower) motor error	● 16 times	—	—	—
Microcomputer error	● 17 times	—	—	—

● : Slow flashing

- : Off

DISASSEMBLY ILLUSTRATION

Models :

MW09Y3FM

MW12Y3FM

MW18Y3FM

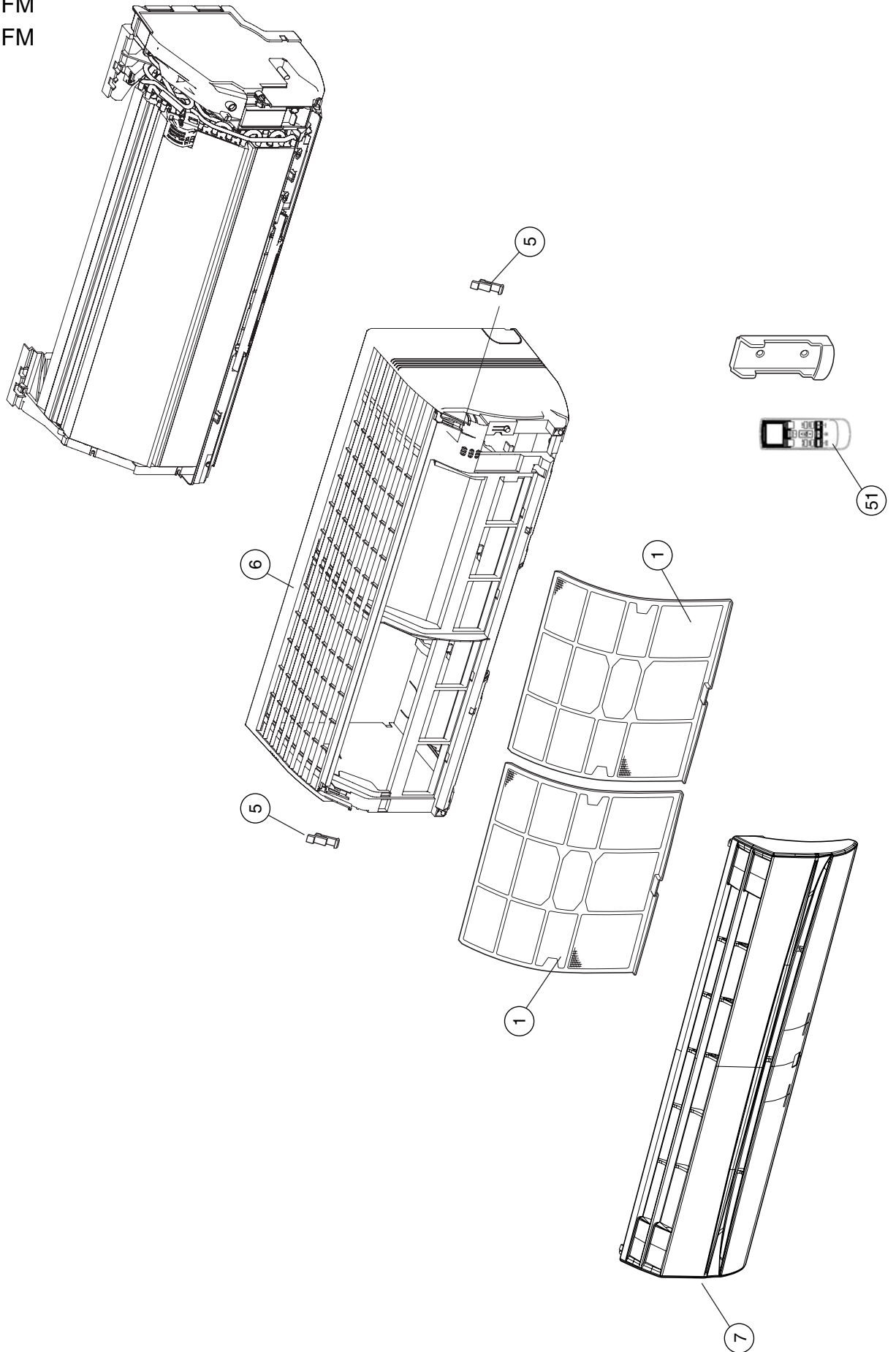

Models :
MW09Y3FM
MW12Y3FM
MW18Y3FM

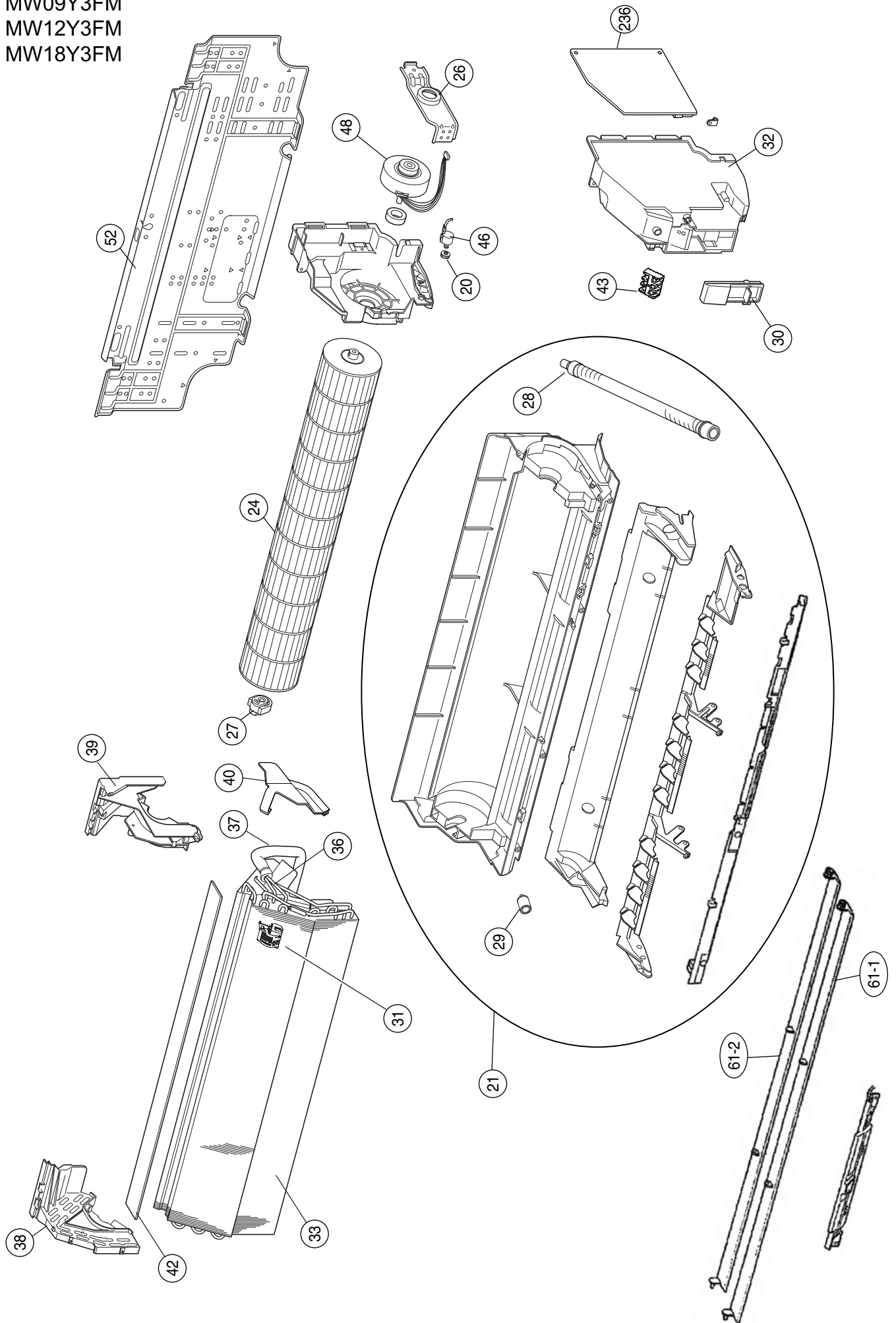

Model : MR36TQY3F

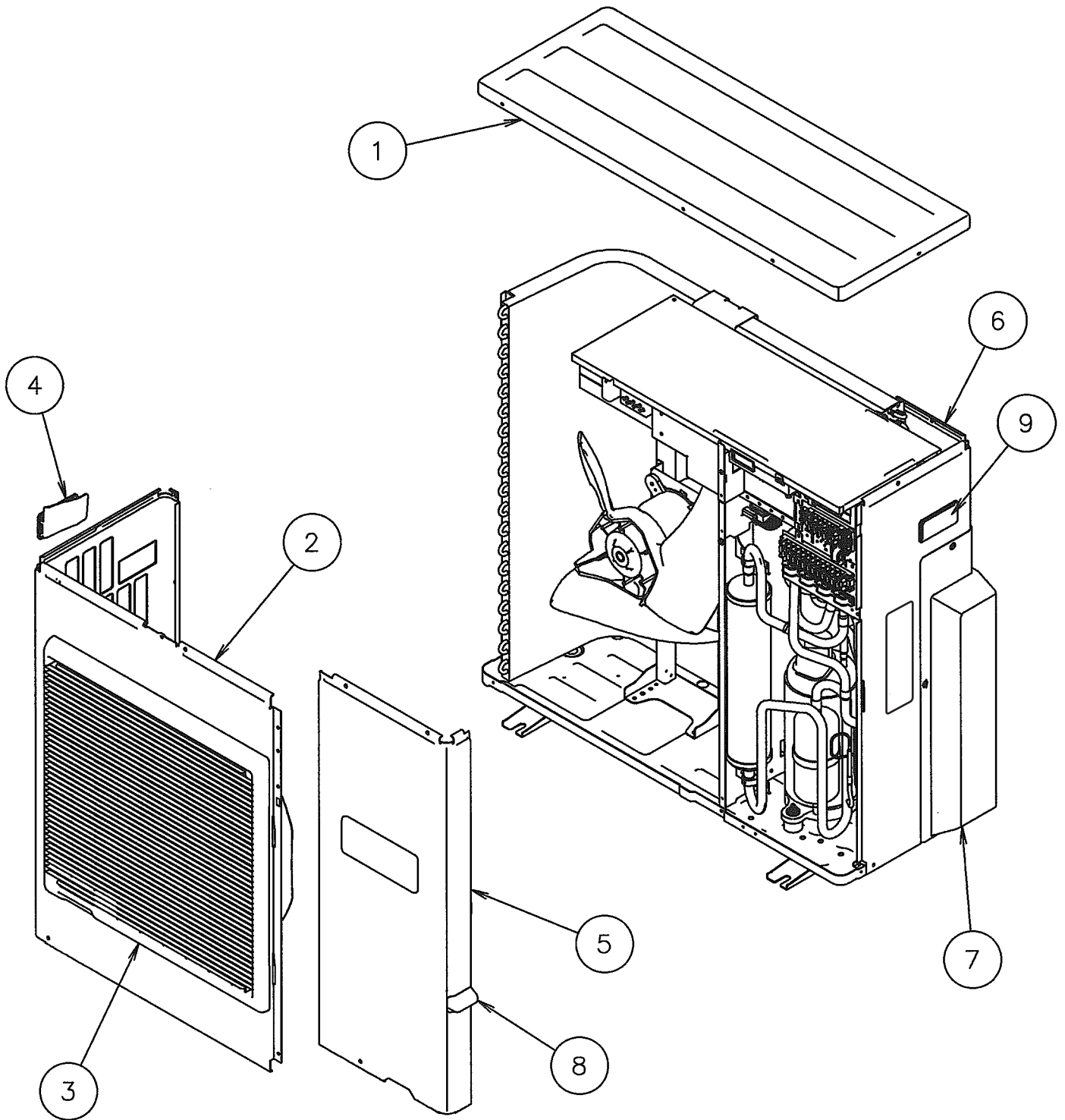

Model : MR36TQY3F

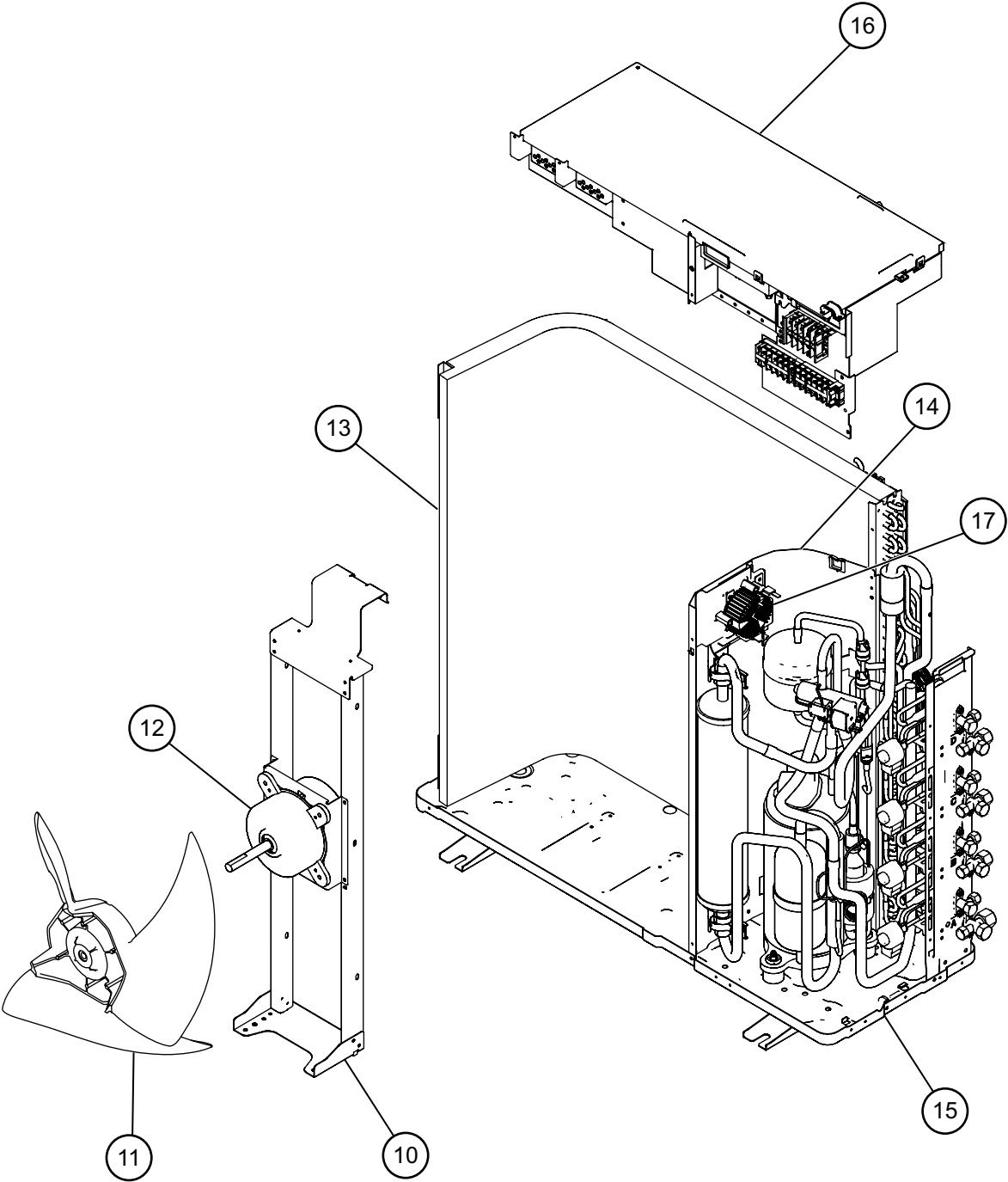

Model : MR36TQY3F

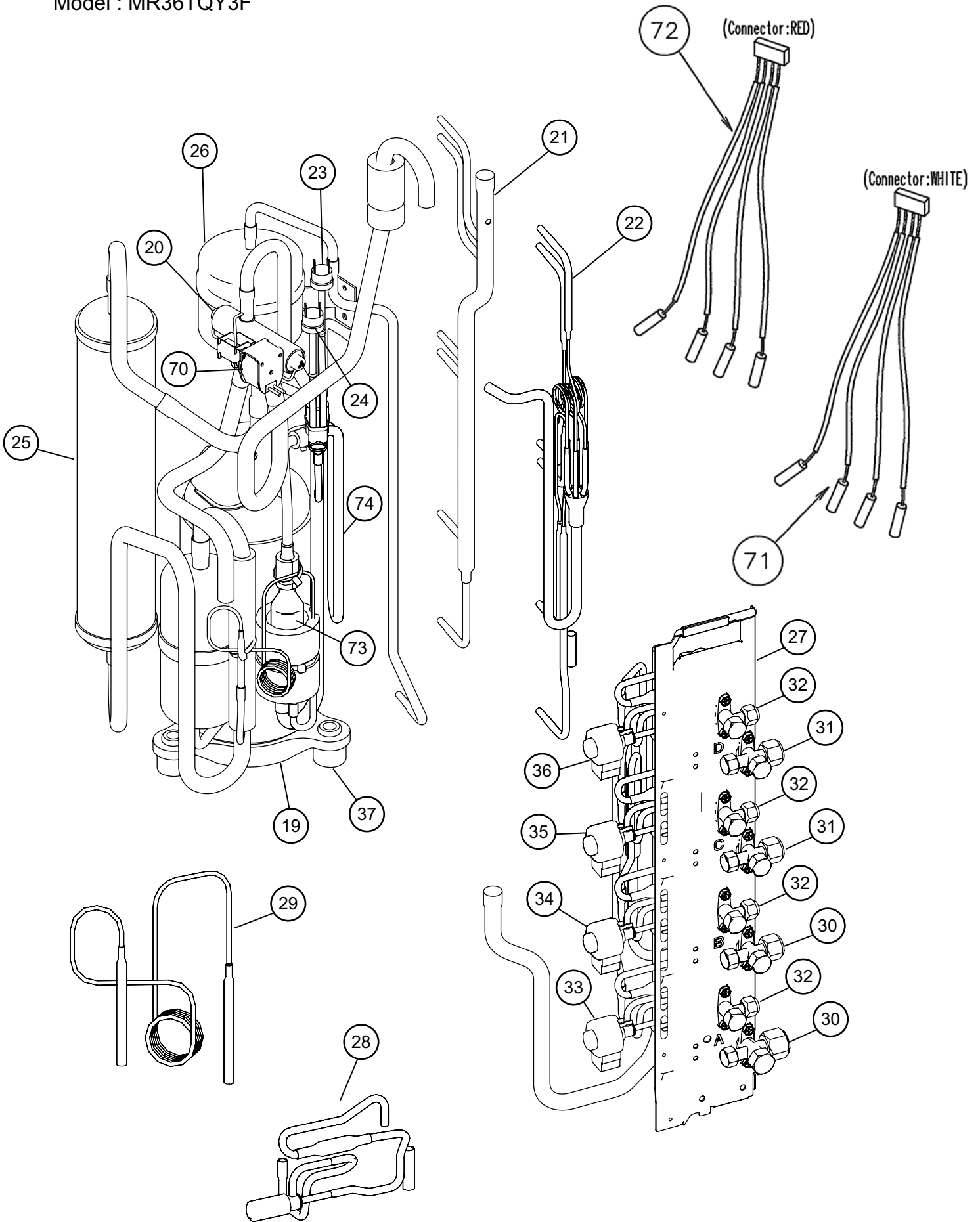

PARTS LIST

INDOOR UNIT

Ref. No	Description	Part No.			Ord. Q'ty
		MW09Y3FM	MW12Y3FM	MW18Y3FM	
1	AirFilter	67201200	67201200	67201200	
5	Clamper (Grille)	67200936	67200936	67200936	
6	FrontPanel	67201230	67201230	67201230	
7	Intake Grille Assy	67201232	67201232	67201232	
20	Gear-A	67201206	67201206	67201206	
21	Casing Assy	67201207	67201207	67201207	
24	Crossflow Fan Assy	67200918	67200918	67200918	
26	Clamp (Motor)	67201234	67201234	67201234	
27	Shaft Holder-C Assy	67200922	67200922	67200922	
28	Drain Hose Assy	67200406	67200406	67200406	
29	Drain Cap Assy	67201211	67201211	67201211	
30	Wire Clamper	67201236	67201236	67201236	
31	Holder(Room Thermistor)	67201248	67201248	67201248	
32	Cover(Switch)	67201213	67201213	67201213	
33	Evaporator Total Assy	67201214	67201214	67201214	
36	Joint Pipe Assy	67201238	67201238	67201238	
37	Insulation (Pipe)-E	67201217	67201217	67201217	
38	Holder (Evaporator)-L Assy	67201239	67201239	67201239	
39	Holder (Evaporator)-R	67201219	67201219	67201219	
40	WaterSeal	67201220	67201220	67201220	
42	AirSeal	67201215	67201215	67201215	
43	Terminal	67201222	67201222	67201222	
46	Step Motor	67201225	67201225	67201225	
48	Fan MotorAssy	67201240	67201240	67201240	
51	Remote Control Unit	67201249	67201249	67201249	
52	BracketPanel	67201242	67201242	67201242	
61-1	Flow Control Panel-U Assy	67201250	67201250	67201250	
61-2	Flow Control Panel-Z Assy	67201251	67201251	67201251	
236	Controller PCB Assy	67201252	67201253	67201254	
		(K04CP-0600HSE-C1)	(K04CP-0601HSE-C1)	(K04CP-0602HSE-C1)	
---	Pipe Temperature Thermistor	67201245	67201245	67201245	
---	Room Temperature Thermistor	67201246	67201246	67201246	
---	Indicator PCB Assy	67201247	67201247	67201247	
---	Evaporator B Assy			67201255	





OUTDOOR UNIT

Ref. No	Description	Part No.	Ord. Q'ty
		MR36TQY3F	
1	Top Panel Sub Assy	67201640	
2	Front Panel M	67201601	
3	Fan Guard	67201602	
4	Grip Side	67201603	
5	Service Panel M	67201641	
6	Right Panel M	67201642	
7	Valve Cover Sub Assy	67201643	
8	Grip Service	67201644	
9	Grip	67201645	
10	Motor Bracket Sub Assy	67201646	
11	Propeller Fan Assy	67201607	
12	Motor. DC Brushless	67201608	
13	CondenserA Assy	67201609	
14	Separate Wall Assy S	67201647	
15	Base Assy	67201648	
16	InverterAssy	67201649	
17	Coil. Choke	67201633	
18	Cap Foot	67201650	
19	Compressor Sub Assy	67201651	
20	4-Way Valve Assy	67201652	
21	Inlet Pipe (Cond) A Assy	67201622	
22	Outlet Pipe (Cond) A Assy	67201653	
23	Pressure Switch A Assy	67201654	
24	Pressure Switch B Assy	67201655	
25	Accumulator Sub Assy	67201656	
26	Receiver Tank Sub Assy	67201657	
27	Valve Plate A Assy	67201658	
28	Expansion Valve Assy	67201659	
29	Capillary Assy	67201660	
30	3-Way Valve Assy (1/2")	67201661	
31	3-Way Valve Assy (3/8")	67201662	
32	2-Way Valve Assy	67201663	
33	Coil (Expansion Valve)(A=Red)	67201470	
34	Coil (Expansion Valve) (B=White)	67201471	
35	Coil (Expansion Valve) (C=Green)	67201468	
36	Coil (Expansion Valve) (D=Blue)	67201469	
37	Rubber Seat (For Comp)	67210122	
38	Gasket	67201664	
39	Holder	67201665	
40	Terminal Cover (Comp)	67201666	

Ref. No	Description	Part No.	Ord. Q'ty
		MR36TQY3F	
41	Washer(Rubber)	67210118	
42	Frange Nut	67210119	
43	Inverter Box A	67201667	
44	Inverter Box B Assy	67201668	
45	Inverter Box C	67201669	
46	Inverter Box Duct	67201670	
47	InverterBox Cover	67201671	
48	Heat Sink A	67201672	
49	Inverter Box D	67201673	
52	Terminal (3P)	67201674	
53	Terminal (6P)	67201675	
58	Terminal	67220181	
59	ACTPM	67201627	
60	PWB Assy (Power Supply)	67201676	
61	PWB Assy (Controller)	67201677	
62	Holder (Thermo)	67201678	
63	Heat Sink Thermistor	67201685	
64	Compressor Temp Thermistor	67201637	
65	Thermistor (Outdoor Temp)	67201686	
66	Heat Exchanger Thermistor	67201639	
67	Discharg Temp Thermistor	67201635	
68	Wire (Pressure Sw)(Red)	67201679	
69	Wire (Pressure Sw)(White)	67201680	
70	Solenoid	67201681	
71	Thermistor (Pipe)(White)	67201682	
72	Thermistor (Pipe)(Red)	67201683	
73	Oil Separater Assy	67201684	
74	Discharg PipeA Assy	67201687	

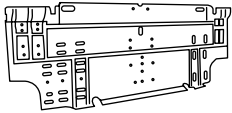
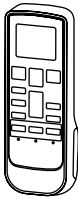
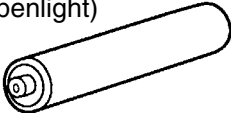
STANDARD ACCESSORIES

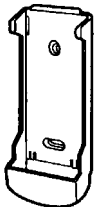
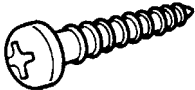
INDOOR UNIT

Name and Shape	Q'ty	Use	Part No.
Wall hook bracket 	1	For indoor unit installation	9310001004
Remote control unit 	1	Use for air conditioner operation	9315260017
Battery (penlight) 	2	For remote control unit	0600185527
Cloth tape 	1	For indoor unit installation	9310519004
Remote control unit holder 	1	Use as remote control unit holder	9305642045
Tpping screw (big) (ϕ 4 x 20) 	8	For wall hook bracket installation	0700076046
Tpping screw (small) (ϕ 3 x 12) 	2	For remote control unit holder installation	0700019036

OUTDOOR UNIT

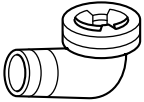
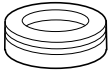
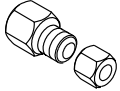
Name and Shape	Q'ty	Use	Part No.
Drain pipe 	1	For outdoor unit drain piping work	9303029015
Drain cap 	5		313166024302
Adapter assy 12.7 mm \rightarrow 9.52 mm (1/2 in.) (3/8 in.) 	1	For use when connecting models 9-12 to outdoor port A	9370244007

0604G3076