

This Owner's Manual is provided and hosted by [Appliance Factory Parts](#).



# FRIEDRICH MR09Y1F Owner's Manual

[Shop genuine replacement parts for FRIEDRICH  
MR09Y1F](#)



[Find Your FRIEDRICH Air Conditioner Parts - Select From 1575 Models](#)

----- Manual continues below -----



**SPLIT TYPE ROOM AIR  
CONDITIONER  
WALL MOUNTED type**

**SERVICE  
MANUAL**

**Models**

**Indoor unit**

MW09Y1F

MW12Y1F

**Outdoor unit**

MR09Y1F

MR12Y1F

**CONTENTS**

SPECIFICATIONS .....	1
OUTLINE AND DIMENSIONS .....	2
REFRIGERANT SYSTEM DIAGRAM .....	3
CIRCUIT DIAGRAM .....	4
INDOOR PCB CIRCUIT DIAGRAM .....	5
DISASSEMBLY ILLUSTRATION .....	10
PARTS LIST .....	13

## SPECIFICATIONS

INDOOR UNIT	MW09Y1F	MW12Y1F
OUTDOOR UNIT	MR09Y1F	MR12Y1F
COOLING CAPACITY	9,700 Btu/h	12,300 Btu/h
HEATING CAPACITY	9,600 Btu/h	12,800 Btu/h

## ELECTRICAL DATA

POWER SOURCE		115 V	115 V
FREQUENCY		60 Hz	60 Hz
RUNNING CURRENT	COOLING	7.6 A	9.9 A
	HEATING	6.5 A	9.2 A
INPUT WATTS	COOLING	820 W	1,070 W
	HEATING	690 W	990 W
SEER		14.3	13.7
MOISTURE REMOVAL		2.1 Pts/hr (1.0 L/hr)	3.2 Pts/hr (1.5 L/hr)
AIR CIRCULATION-HIGH		560 m <sup>3</sup> /hr	660 m <sup>3</sup> /hr

## COMPRESSOR

TYPE	Hermetic type, Permanent split condenser, 2 pole, Single phase, Induction motor	
DISCRIMINATION	EA89X1C-1DZDU1	EA118X1C-1FZDU1
POWER SOURCE	115V 60Hz	115V 60Hz
REFRIGERANT	R-410A 1 lb.10 oz ( 750 g )	2 lb. 3 oz ( 1000 g )

## FAN MOTOR

POWER SOURCE		115 V	115 V
INDOOR UNIT	HIGH	C 1,250 r.p.m. / H 1,250 r.p.m.	C 1,450 r.p.m. / H 1,400 r.p.m.
	MED	C 1,100 r.p.m. / H 1,110 r.p.m.	C 1,250 r.p.m. / H 1,230 r.p.m.
	LOW	C 950 r.p.m. / H 970 r.p.m.	C 1,050 r.p.m. / H 1,060 r.p.m.
	Cool / Heat QUIET	C 800 r.p.m. / H 820 r.p.m.	C 850 r.p.m / H 900 r.p.m.
OUTDOOR UNIT		640 r.p.m.	770 r.p.m.

## DIMENSIONS

INDOOR UNIT	H x W x D	10-13/16 x 31-1/8 x 8-7/16 inch
		275 x 790 x 215 mm
OUTDOOR UNIT	H x W x D	21-1/4 x 31-1/8 x 11-7/16 inch
		540 x 790 x 290 mm

## WEIGHT

INDOOR UNIT	Gross / Net	26 / 20 lbs. (12 / 9 kg )	
OUTDOOR UNIT	Gross / Net	79 / 71 lbs. (36 / 32 kg )	88 / 79 lbs. (40 / 36 kg )

# OUTLINE AND DIMENSIONS

Unit : inch (mm)

Models :

MW09Y1F / MR09Y1F

MW12Y1F / MR12Y1F

## INDOOR UNIT

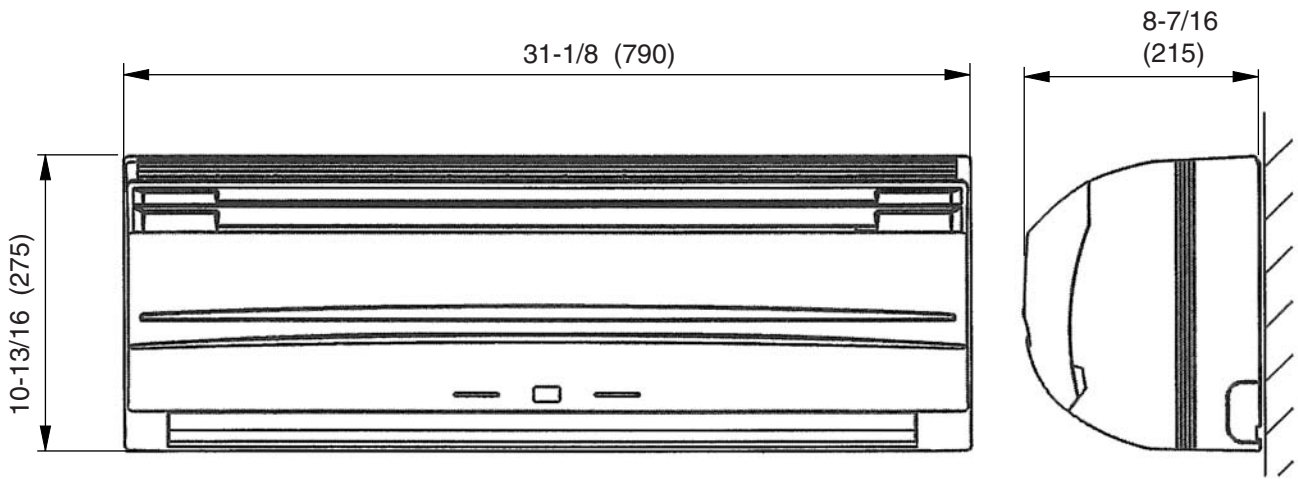

## OUTDOOR UNIT

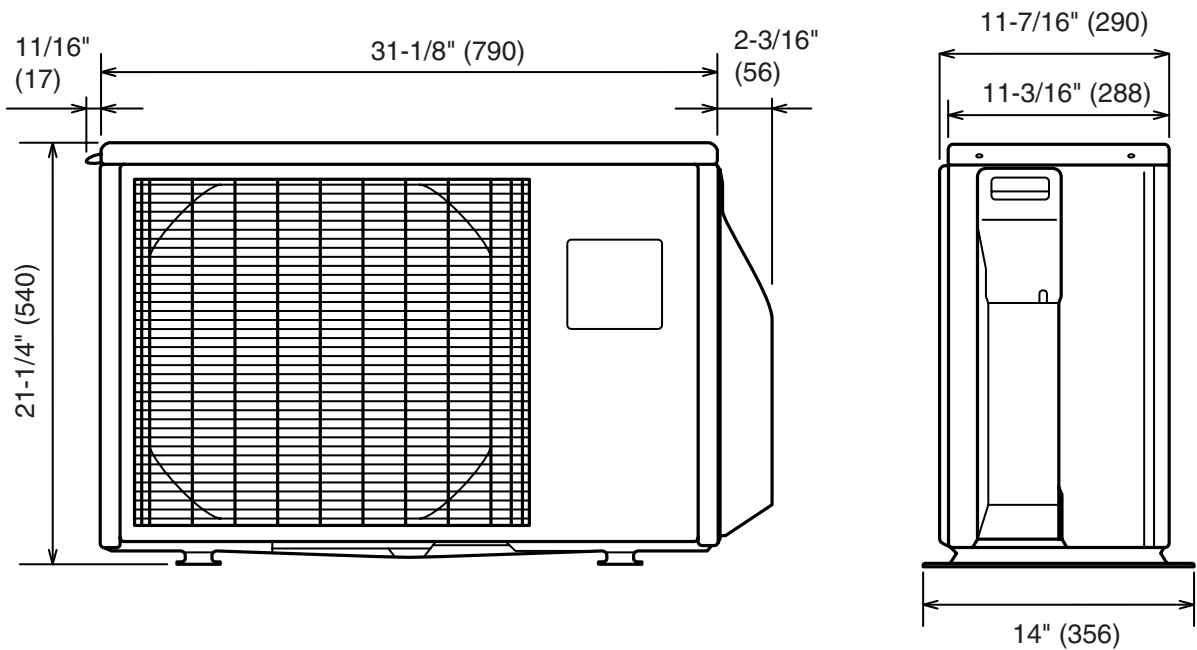

# REFRIGERANT SYSTEM DIAGRAM

Models :  
 MW09Y1F / MR09Y1F  
 MW12Y1F / MR12Y1F

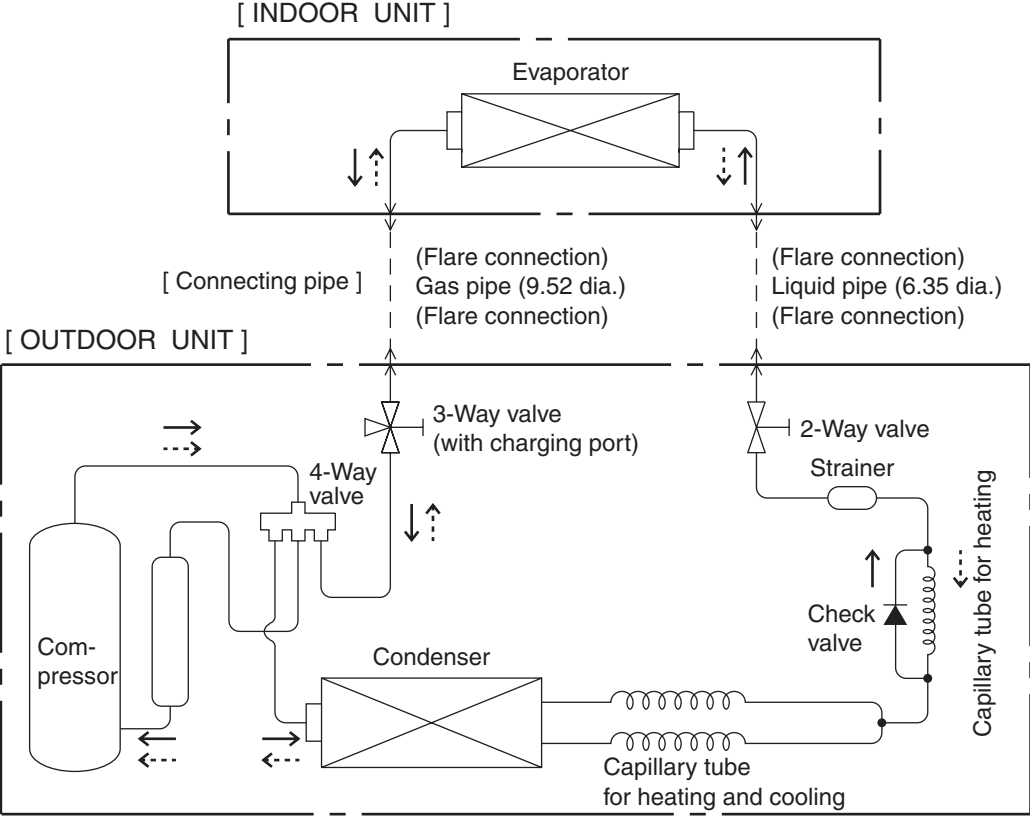

Cooling →  
 Heating ⇌

# CIRCUIT DIAGRAM

Models :  
 MW09Y1F / MR09Y1F  
 MW12Y1F / MR12Y1F

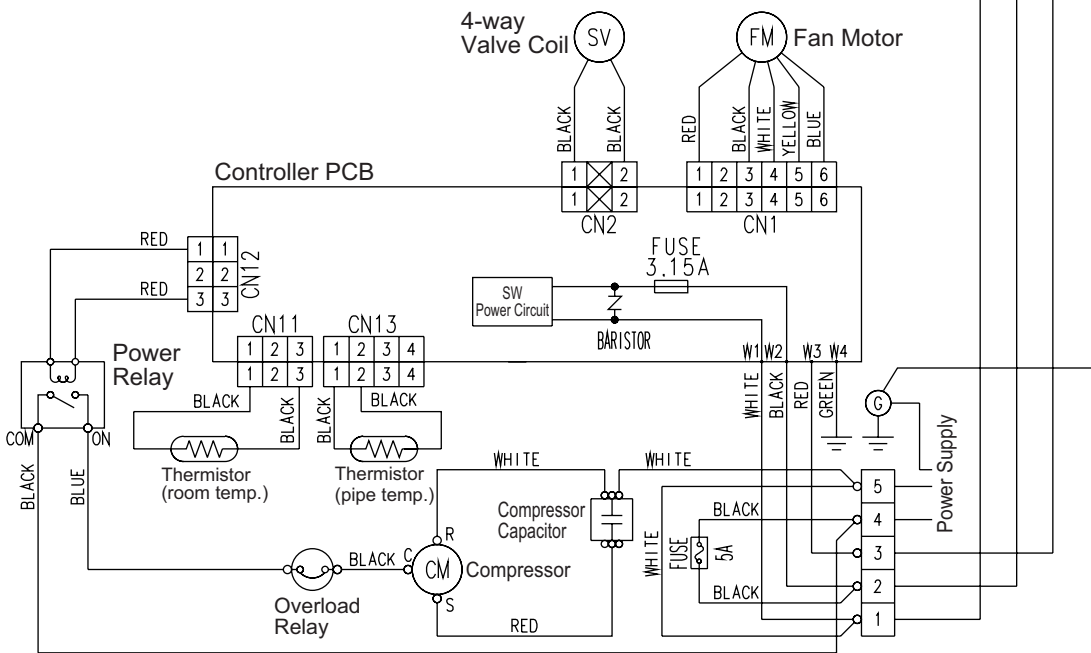
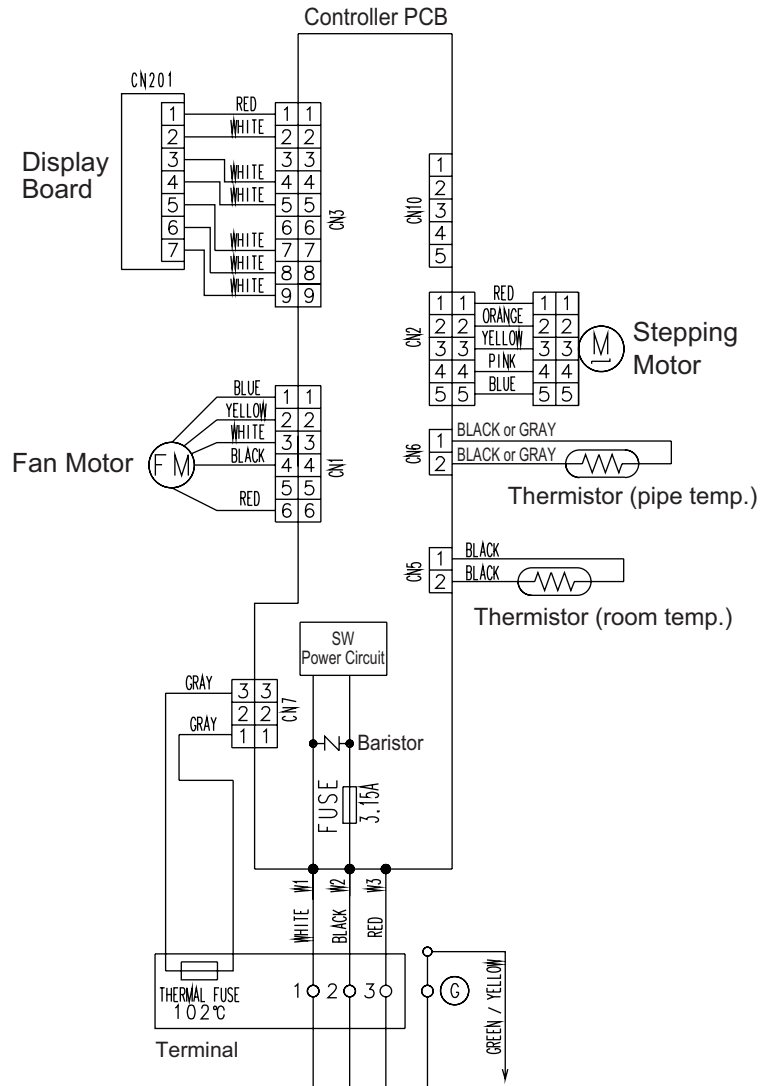

# INDOOR PCIRCUITB CIRCUIT DIAGRAM

Models :  
 MW09Y1F, MW12Y1F

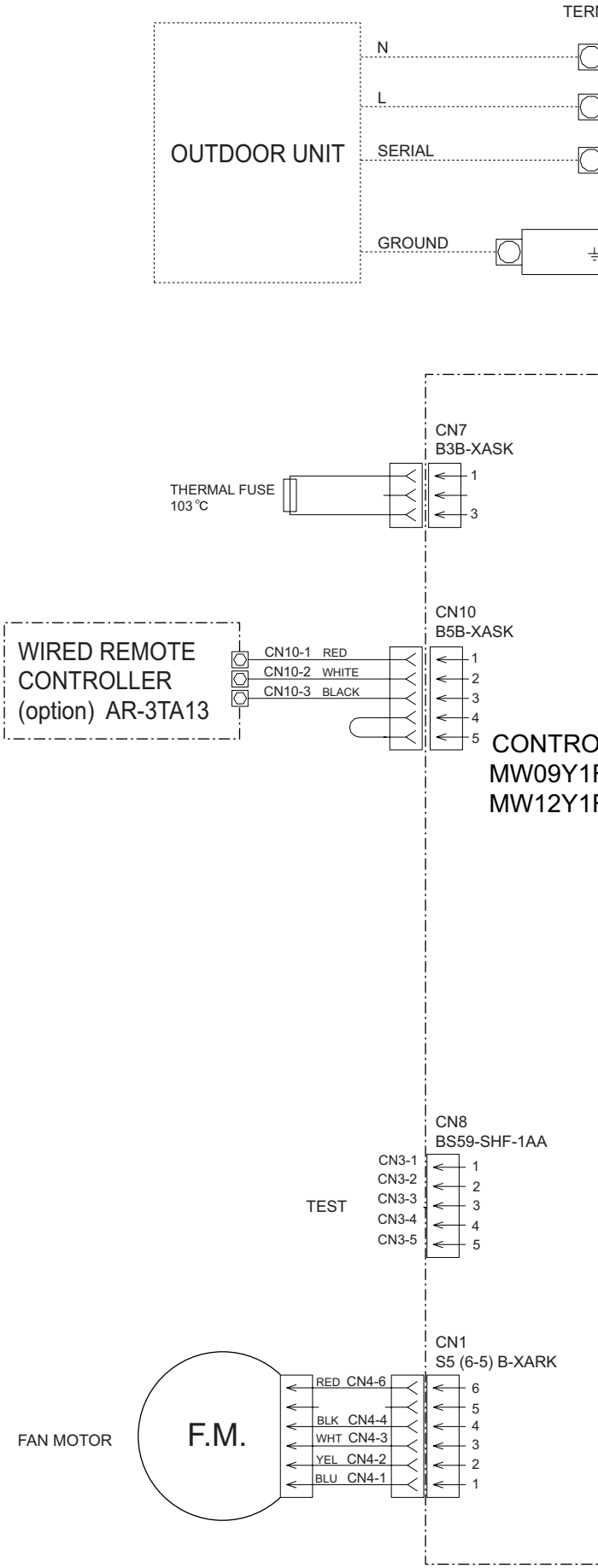

Models : MW09Y1F, MW12Y1F

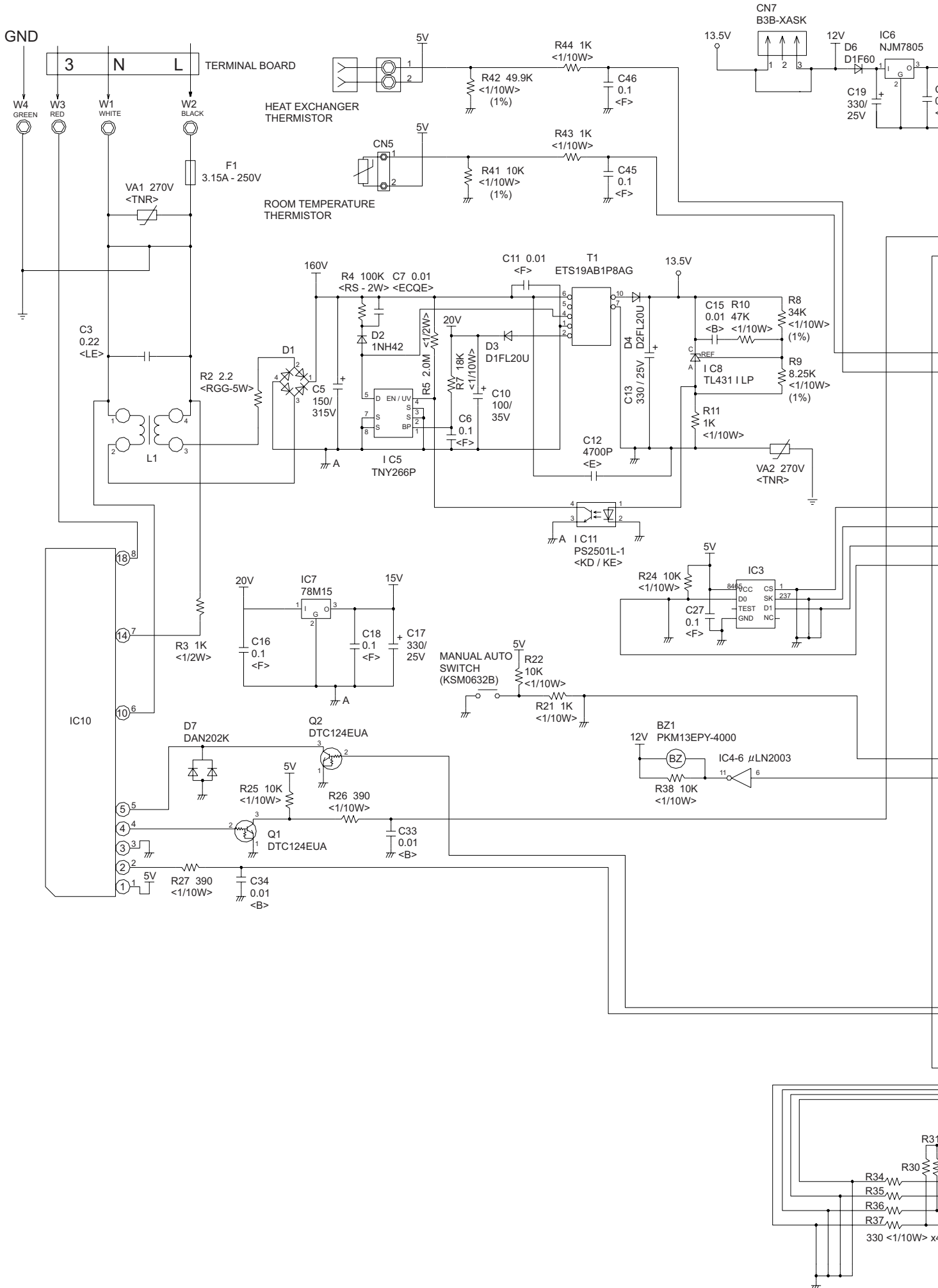

# OUTDOOR PCB CIRCUIT DIAGRAM

Models : MR09Y1F, MR12Y1F

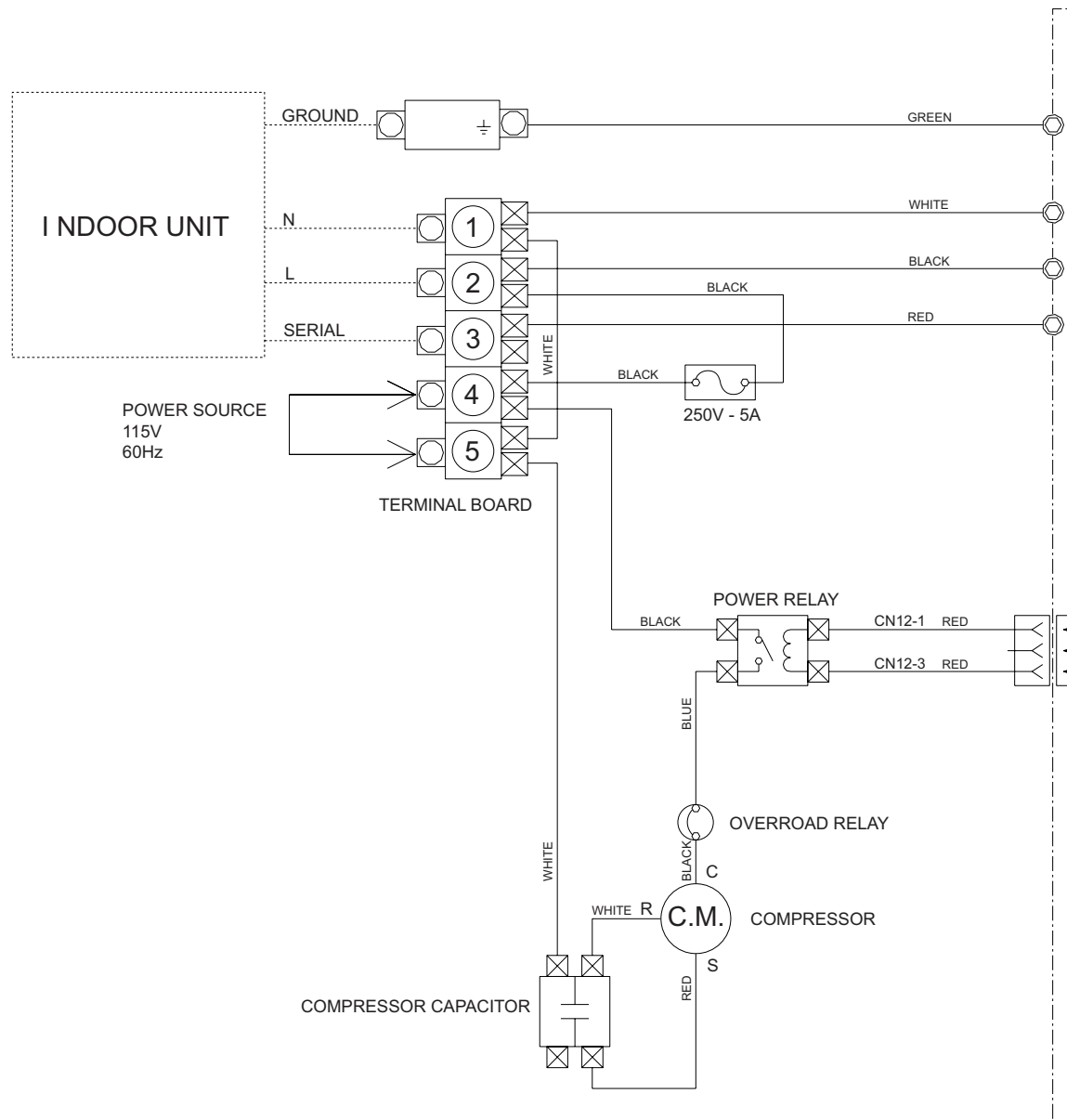

Models : MR09Y1F, MR12Y1F

CONTROLLER PCB A  
 MR09Y1F : K0  
 MR12Y1F : K0

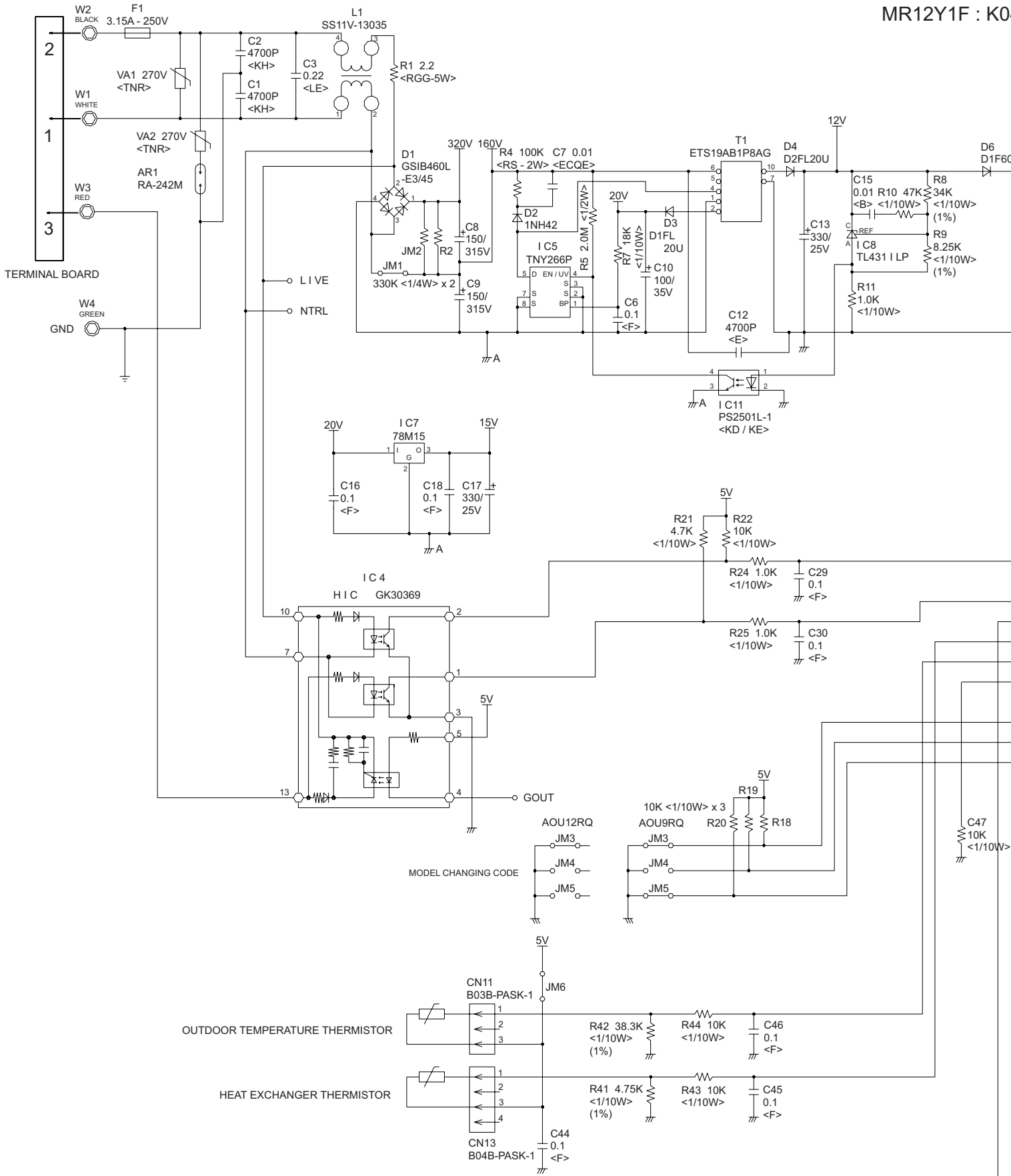

## ERROR CONTENTS

Kind of error	Indication on LED		Indication on wired remote controller	Contents
	Operation LED (red)	Timer LED (green)		
Communication	Off	0.5 sec / twice	<b>01</b>	Serial (reverse) error after operation
		0.5 sec / three times		Serial (reverse) error during operation
		0.5 sec / four times		Serial (forward) error after operation
		0.5 sec / five times		Serial (forward) error during operation
Indoor unit Thermistor	0.5 sec / twice	0.5 sec / twice	<b>02</b>	Room temp. thermistor error open / short
		0.5 sec / three times		<b>04</b>
Outdoor unit Thermistor	0.5 sec / three times	0.5 sec / three times	<b>06</b>	Heat exchange thermistor error open
		0.5 sec / four times		<b>0A</b>
Indoor unit PCB	0.5 sec / four times	0.5 sec / eight times	<b>21</b>	Opposite VDD permanent stop protection (Electric aircleaner, circuit error)
Outdoor unit PCB	0.5 sec / five times	0.5 sec / six times	<b>1b</b>	Outdoor unit fan control error
Indoor unit fan motor	0.5 sec / six times	0.5 sec / twice	<b>12</b>	Lock
		0.5 sec / three times		r.p.m abnormal
Power supply	0.1 sec flashing on red and orange LED		No Indication	Power supply abnormal
Model distinction	0.1 sec flashing on all LED		<b>11</b>	Model distinction error

# DISASSEMBLY ILLUSTRATION

Models : MW09Y1F  
MW12Y1F

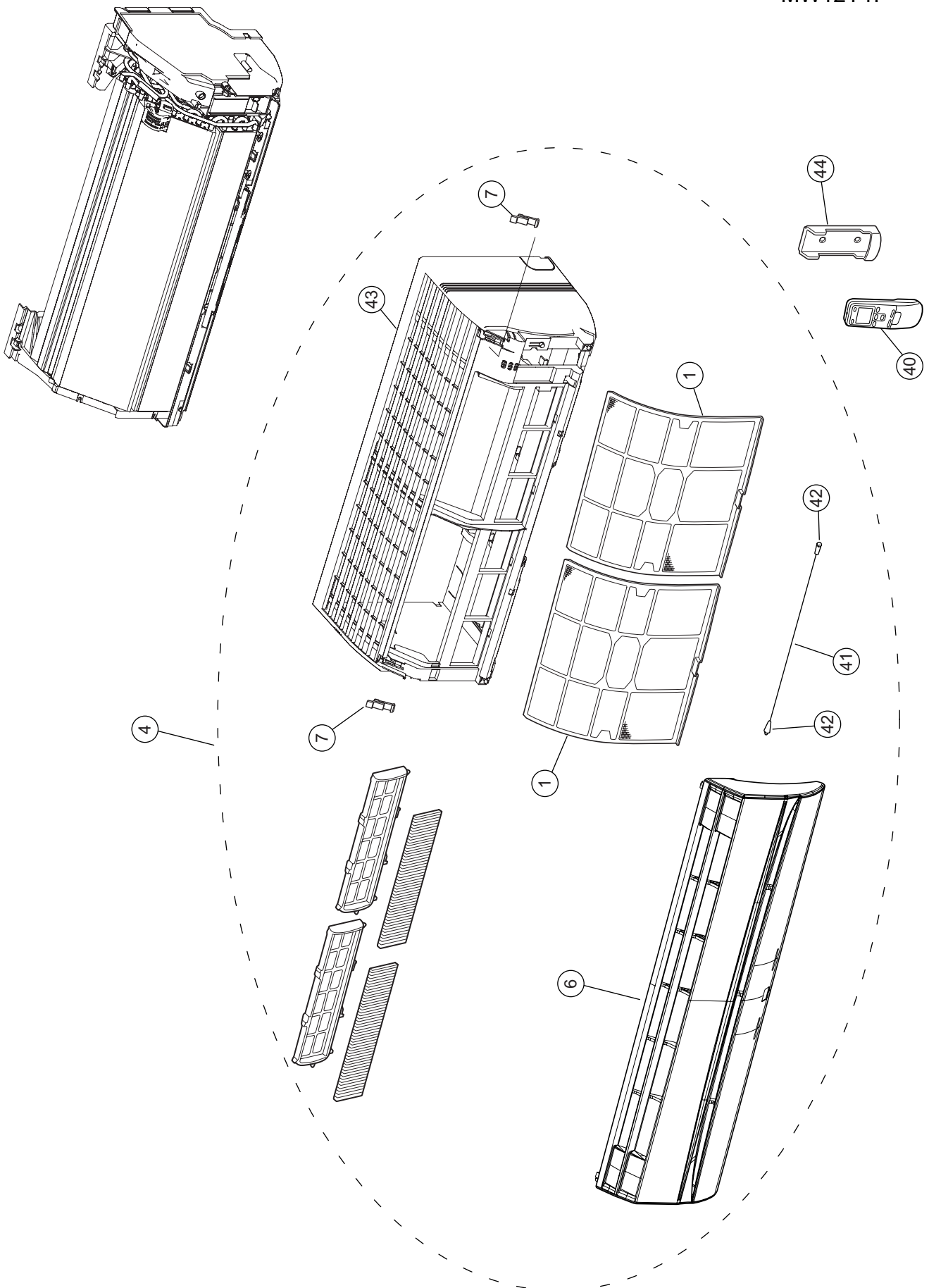

Models : MW09Y1F  
MW12Y1F

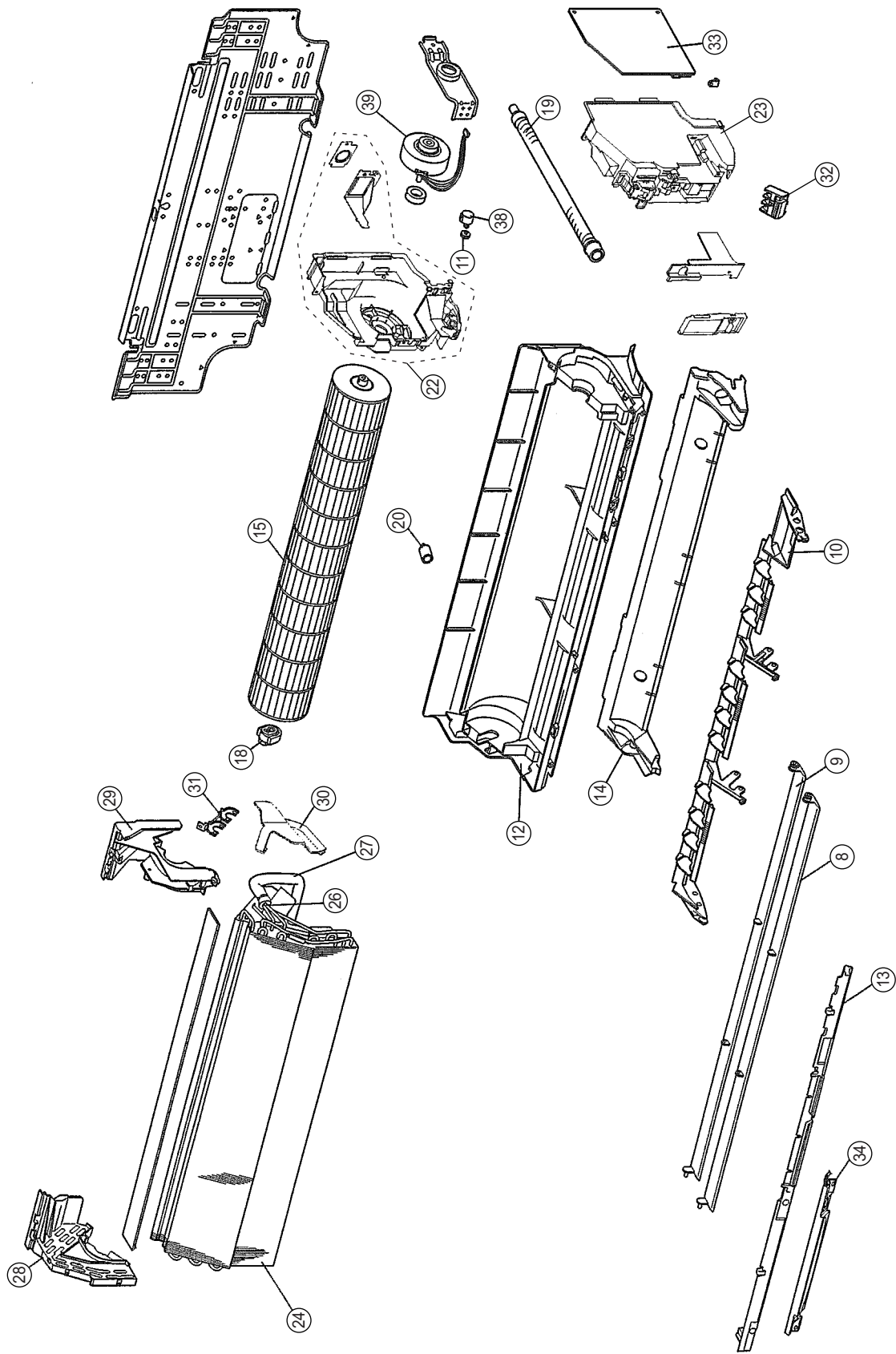

Models : MR09Y1F  
MR12Y1F

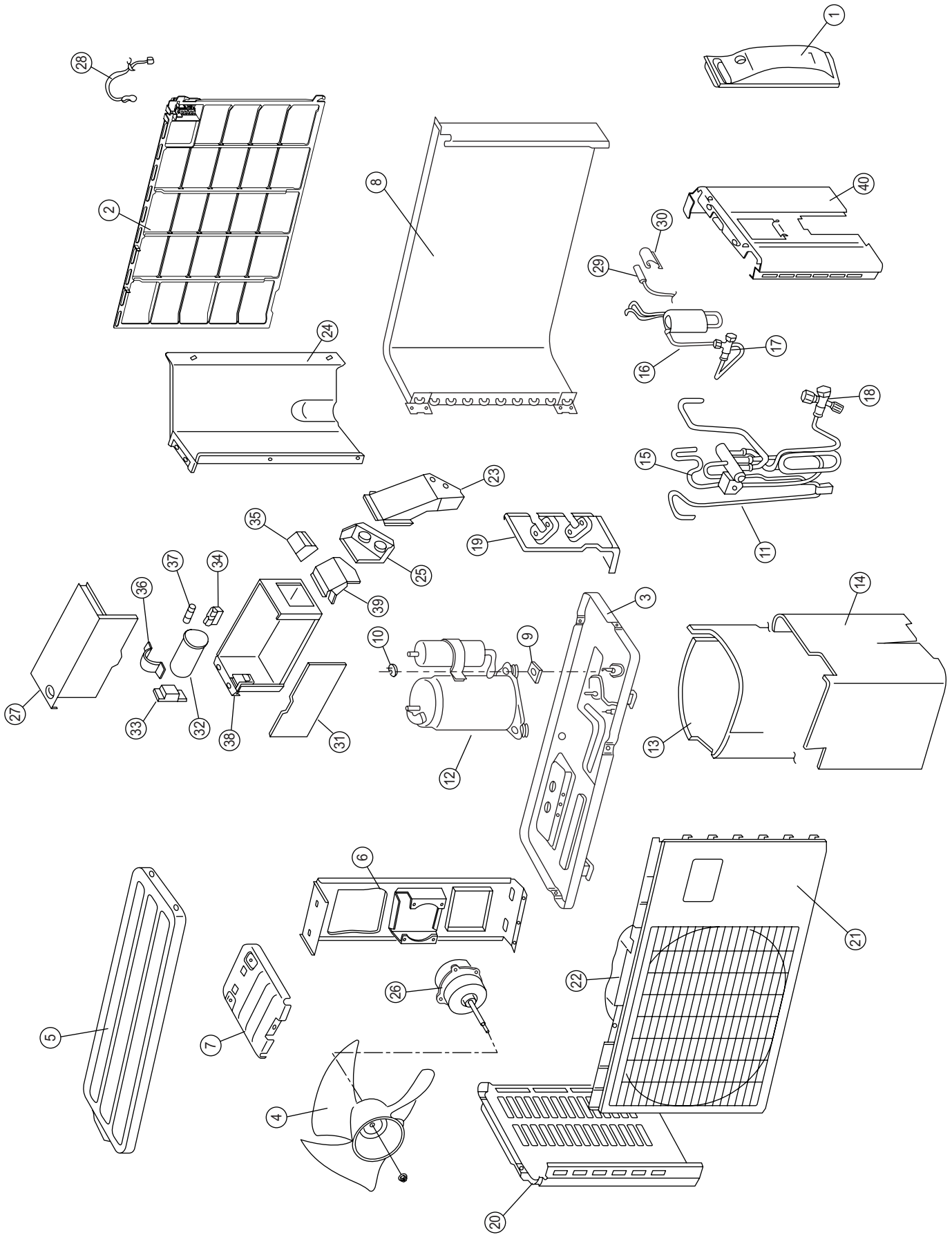

# PARTS LIST





## INDOOR UNIT

Ref. No	Description	Part No.		Ord. Q'ty
		MW09Y1F	MW12Y1F	
1	Air Filter	67201200	67201200	
4	Front Panel Total Assy	67201262	67201262	
6	Intake Grille Assy	67201202	67201202	
7	Grille Clamper	67200936	67200936	
8	Louver U	67201203	67201203	
9	Louver Z	67201204	67201204	
10	Louver Holder	67201205	67201205	
11	Gear-A	67201206	67201206	
12	Casing Assy	67201207	67201207	
13	Casing Cover-F	67201208	67201208	
14	Casing Cover-B	67201209	67201209	
15	Crossflow Fan Assy	67200918	67200918	
18	Shaft Holder-C	67200922	67200922	
19	Drain Hose Assy	67200913	67200913	
20	Drain Cap Assy	67201211	67201211	
22	Switch Box Assy	67201212	67201212	
23	Box Switch	67201213	67201213	
24	Evaporator Total Assy	67201214	67201214	
25	Evaporator Seal	67201215	67201215	
26	Joint Pipe Assy	67201263	67201263	
27	Insulation (Pipe)-E	67201217	67201217	
28	Holder (Evaporator)-L	67201218	67201218	
29	Holder (Evaporator)-R	67201219	67201219	
30	Water Seal	67201220	67201220	
31	Evaporator Bracket	67201221	67201221	
32	Terminal	67201222	67201222	
33	Controlle PCB Assy	67201264	67201266	
		(K04CP-0404HSE-C1)	(K04CP-0405HSE-C1)	
34	Display PCB Assy	67201224	67201224	
38	Stepping Motor	67201225	67201225	
39	Fan Motor Assy	67201226	67201226	
40	Remote Control Unit	67201265	67201265	
41	Grille Guard	67201228	67201228	
42	Bushing	67201229	67201229	
43	Front Panel	67201230	67201230	
44	Remote Control Unit Holder	67203202	67203202	

OUTDOOR UNIT

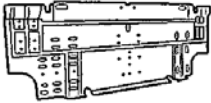
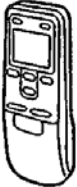
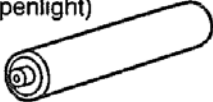
Ref. No	Description	Part No.		Ord. Q'ty
		MR09Y1 F	MR12Y1 F	
1	Cover (Switch)	67201300	67201300	
2	Protective Net	67201301	67201301	
3	Base Assy, Painted	67201302	67201302	
4	Propeller Fan	67201303	67201303	
5	Panel (Top), Painted	67201304	67201304	
6	Motor Bracket	67201305	67201305	
7	Rem Plate	67201306	67201306	
8	Condenser Total Assy	67201351	67201348	
9	Spacer (Rubber)	67201308	67201308	
10	Nut Special Assy	67201309	67201309	
11	Solenoid	67201343	67201343	
12	Compressor Assy	67201311	67201340	
13	Noise Ins A	67201344	67201344	
14	Noise Ins B	67201313	67201313	
15	4-Way Valve Assy	67201345	67201345	
16	Capillary Assy	67201346	67201349	
17	2-Way Valve Assy	67201316	67201316	
18	3-Way Valve Assy	67201317	67201317	
19	Bracket (Valve)	67201318	67201318	
20	Cabinet Lfet, Painted	67201319	67201319	
21	Panel (Front)	67201320	67201320	
22	Ring (Fan)	67201321	67201321	
23	Cover Terminal C	67201322	67201322	
24	Separater C	67201323	67201323	
25	Bracket Conduit	67201324	67201324	
26	Motor, DC Brushless	67201325	67201325	
27	Control Cover	67201326	67201326	
28	Thermistor (Outdoor temp)	67201327	67201327	
29	Heat Exchngr Thermistor	67201352	67201352	
30	Thermistort Spring	67201412	67201412	
31	Pwb Assy	67201347	67201350	
32	Capacitor Plastic	67201329	67201329	
33	Relay	67201330	67201330	
34	Fuse Holder	67201331	67201331	
35	Terminal	67201332	67201332	
36	Clamp Metal (Capacitor)	67200954	67200954	
37	Fuse	67201333	67201333	
38	Control Box Assy	67201334	67201334	
39	Bracket Terminal	67201335	67201335	
40	Cabinet Right, Painted	67201336	67201336	
---	Emblem Rear	67201337	67201337	

## STANDARD ACCESSORIES

Name and Shape	Q'ty	Use
Wall hook bracket 	1	For indoor unit installation 9310001004
Remote control unit 	1	Use for air conditioner operation 9314785016
Battery (penlight) 	1	For remote control unit 0600185527
Cloth tape 	1	For indoor unit installation 9310519004
Remote control unit holder 	1	Use as remote control unit holder 9305642014
Tapping screw (big) ( $\phi 4 \times 20$ ) 	8	For wall hook bracket installation 0700076046
Tapping screw (small) ( $\phi 3 \times 12$ ) 	2	For remote control unit holder installation 0700019036

