

This Owner's Manual is provided and hosted by [Appliance Factory Parts](http://ApplianceFactoryParts.com).



FRIEDRICH MR30C3F Owner's Manual

[Shop genuine replacement parts for FRIEDRICH MR30C3F](#)

Model : MR30C3F

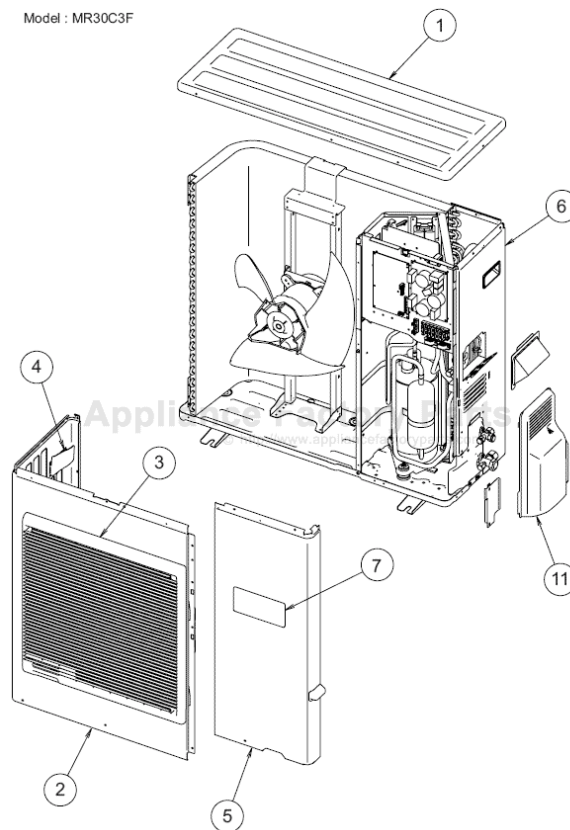

[Find Your FRIEDRICH Air Conditioner Parts - Select From 1575 Models](#)

----- Manual continues below -----



**SPLIT TYPE
ROOM AIR CONDITIONER
WALL MOUNTED type**

**SERVICE
MANUAL**

Models

Indoor unit	Outdoor unit
MW30C3F	MR30C3F

CONTENTS

SPECIFICATIONS.....	1
DIMENSIONS	2
REFRIGERANT SYSTEM DIAGRAM....	4
CIRCUIT DIAGRAM	5
INDOOR PCB CIRCUIT DIAGRAM	6
OUTDOOR PCB CIRCUIT DIAGRAM ...	9
ERROR CONTENTS	14
DISASSEMBLY ILLUSTRATION	15
PARTS LIST	23
STANDARD ACCESSORIES.....	25

SPECIFICATIONS

INDOOR UNIT	MW30C3F
OUTDOOR UNIT	MR30C3F
COOLING CAPACITY	30,700 BTU/hr

ELECTRICAL DATA

POWER SOURCE	208 V / 230 V
FREQUENCY	60 Hz
RUNNING CURRENT	15.2 A
INPUT WATTS	3,460 W
SEER	15.0
MOISTURE REMOVAL	9.7 Pts/hr (4.6 L/hr)
AIR CIRCULATION-High	647 cfm (1,100 m ³ /hr)

COMPRESSOR

TYPE	Hermetic motor compressor, 4 poles, Rotary type
DISCRIMINATION	5KD240XAD21
POWER SOURCE	208 V / 230 V 60Hz
REFRIGERANT R-410A	4 lb.10 oz (2,100 g)

FAN MOTOR

POWER SOURCE	208 V / 230 V	
INDOOR UNIT	HIGH	1,330 r.p.m.
	MED	1,120 r.p.m.
	LOW	940 r.p.m.
	QUIET	830 r.p.m.
OUTDOOR UNIT	850 r.p.m.	

DIMENSIONS

INDOOR UNIT H x W x D	12-5/8 x 39-1/4 x 9 inch
	320 x 998 x 228 mm
OUTDOOR UNIT H x W x D	32-3/4 x 35-3/8 x 13 inch
	830 x 900 x 300 mm

WEIGHT

INDOOR UNIT	Gross / Net	40 / 31 lbs. (18 / 14 kg)
OUTDOOR UNIT	Gross / Net	155 / 137 lbs. (70 / 62 kg)

NOISE LEVEL

INDOOR UNIT	HIGH	47 dB
	MED	41 dB
	LOW	36 dB
	QUIET	32 dB
OUTDOOR UNIT		53 dB

REFRIGERANT CHARGE (R410A)

FULL CHARGE	Pipe length 20 m	4 lb. 10 oz. (2,100 g)
	30 m	5 lb. 8 oz. (2,500 g)
	40 m	6 lb. 6 oz. (2,900 g)
	50 m	7 lb. 4 oz. (3,300 g)
ADDITIONAL CHARGE		40 g/m

OUTLINE AND DIMENSIONS

Unit : inch (mm)

INDOOR UNIT

Model : MW30C3F

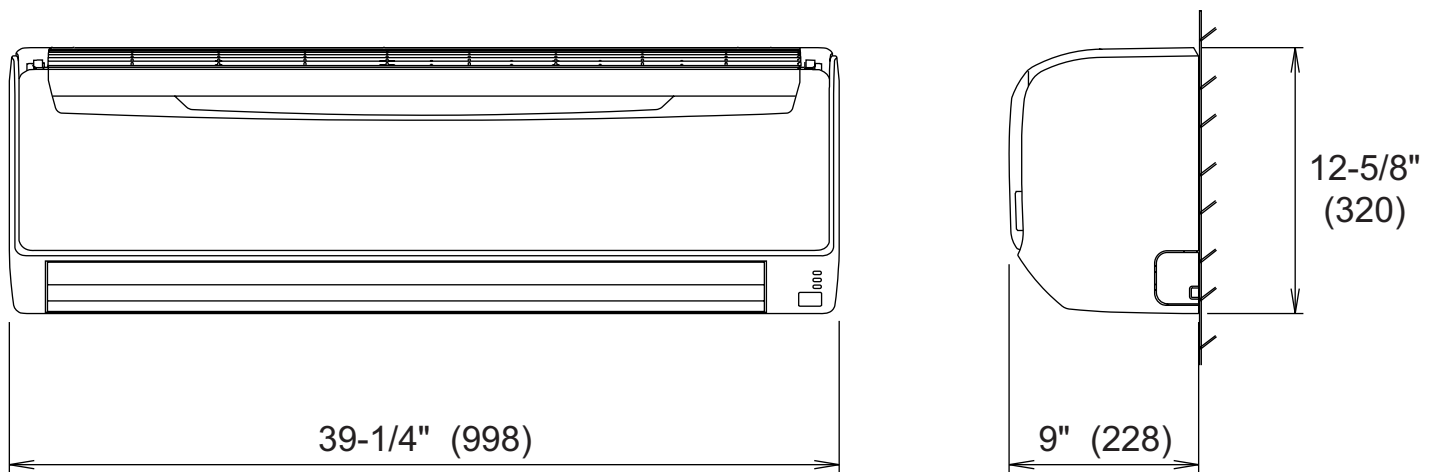

OUTDOOR UNIT

Model : MR30C3F

Unit : inch (mm)

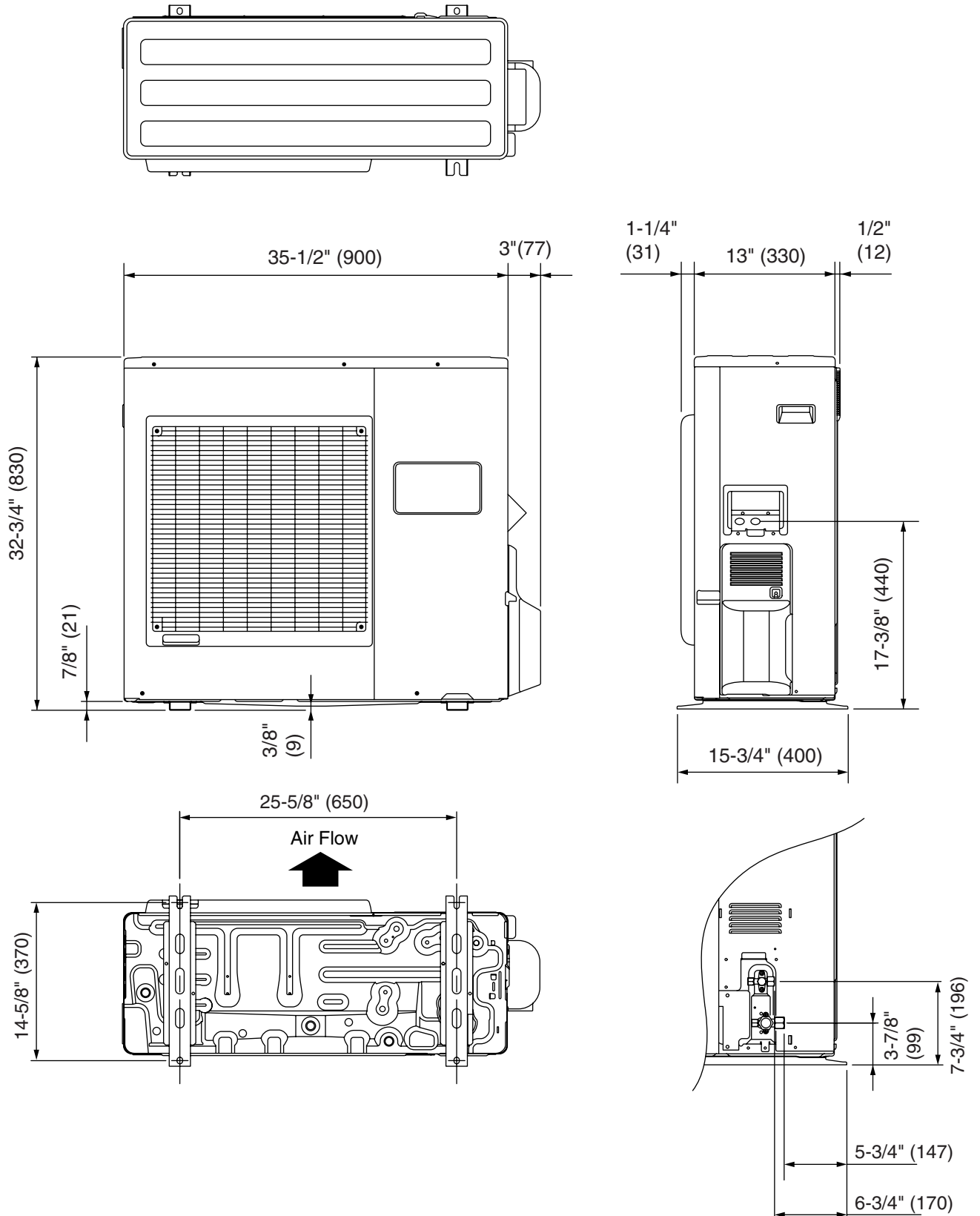

REFRIGERANT SYSTEM DIAGRAM

Models : MW30C3F / MR30C3F

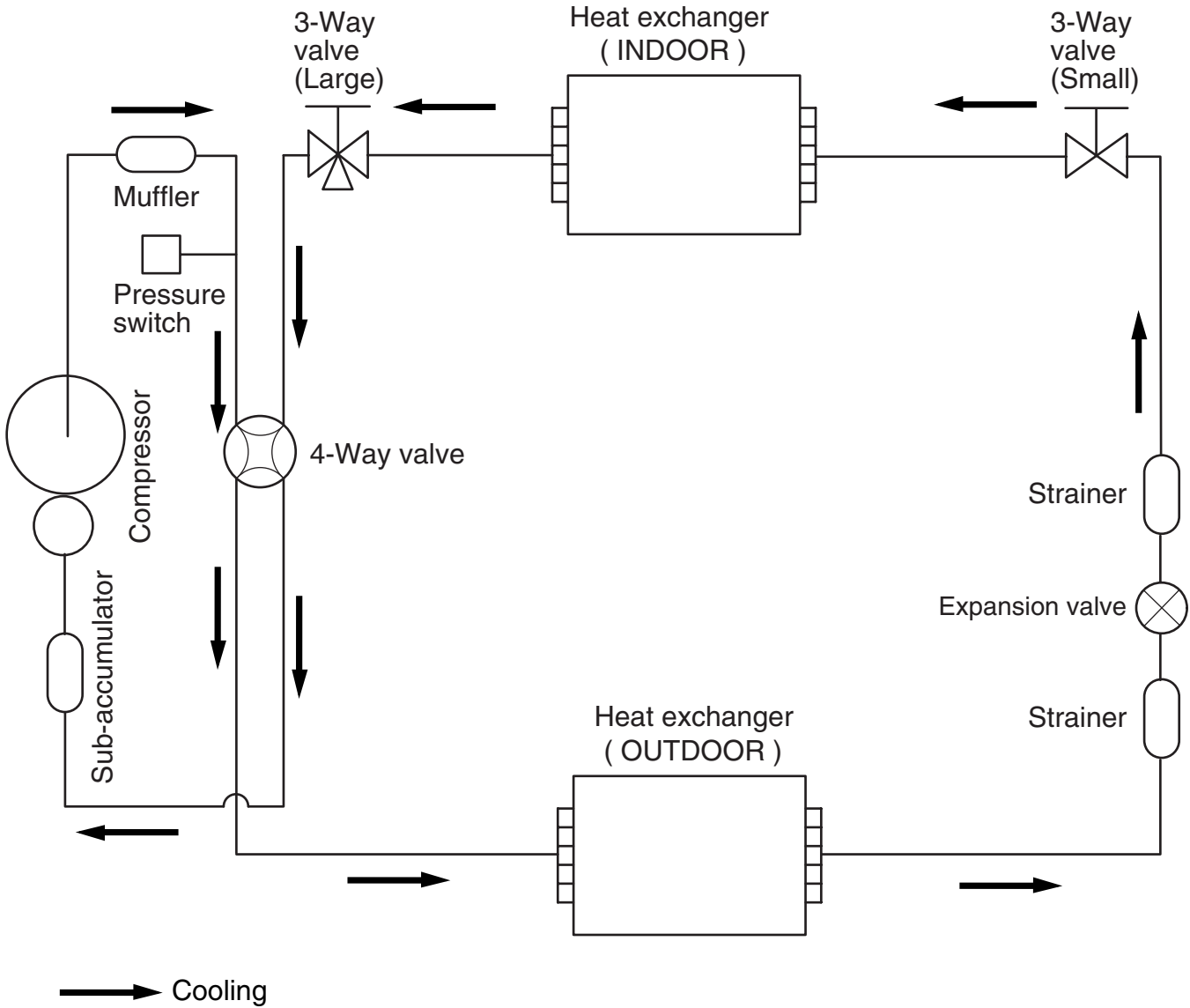

Refrigerant pipe diameter
 Liquid : 3/8" (9.52 mm)
 Gas : 5/8" (15.88 mm)

INDOOR PCB CIRCUIT DIAGRAM

Model : MW30C3F

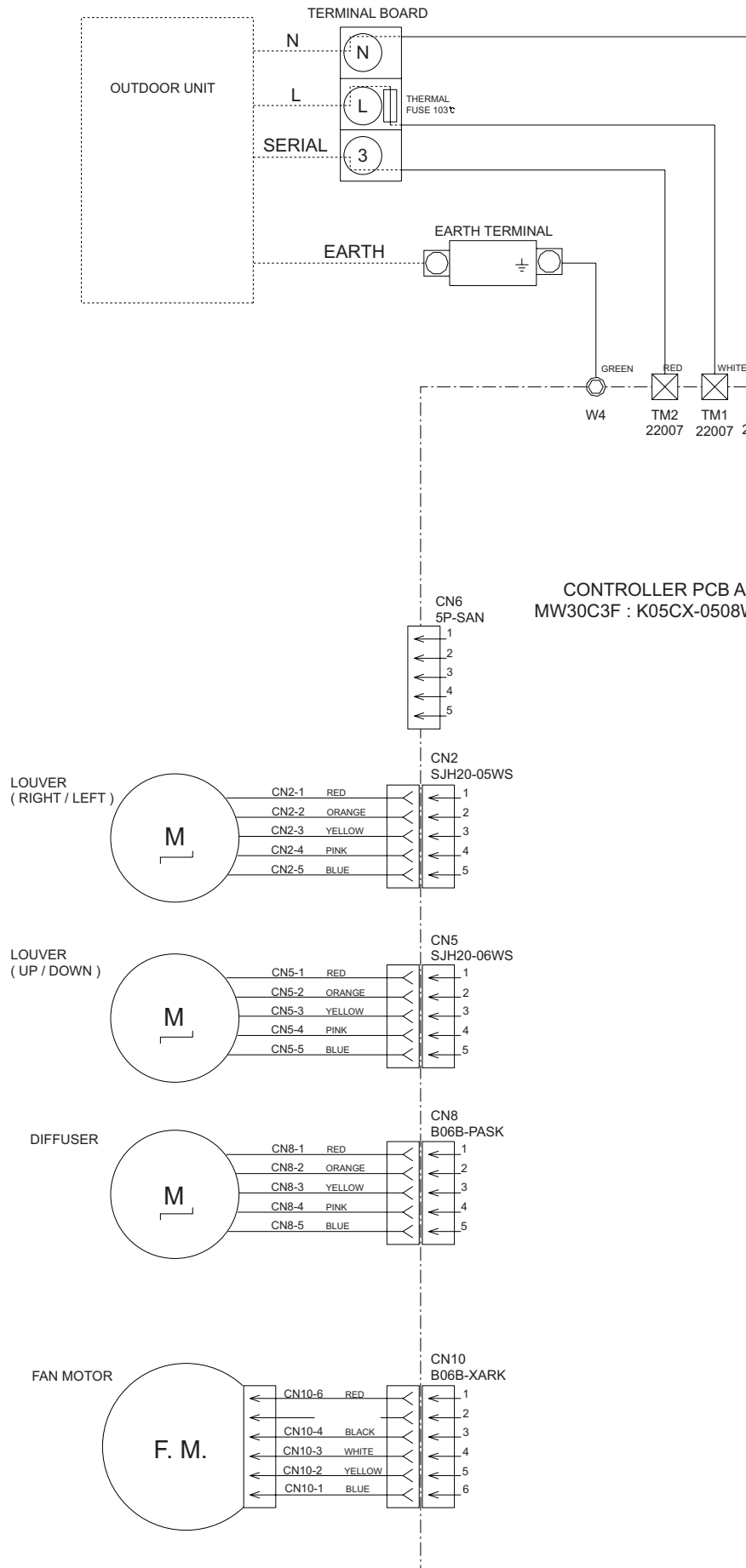

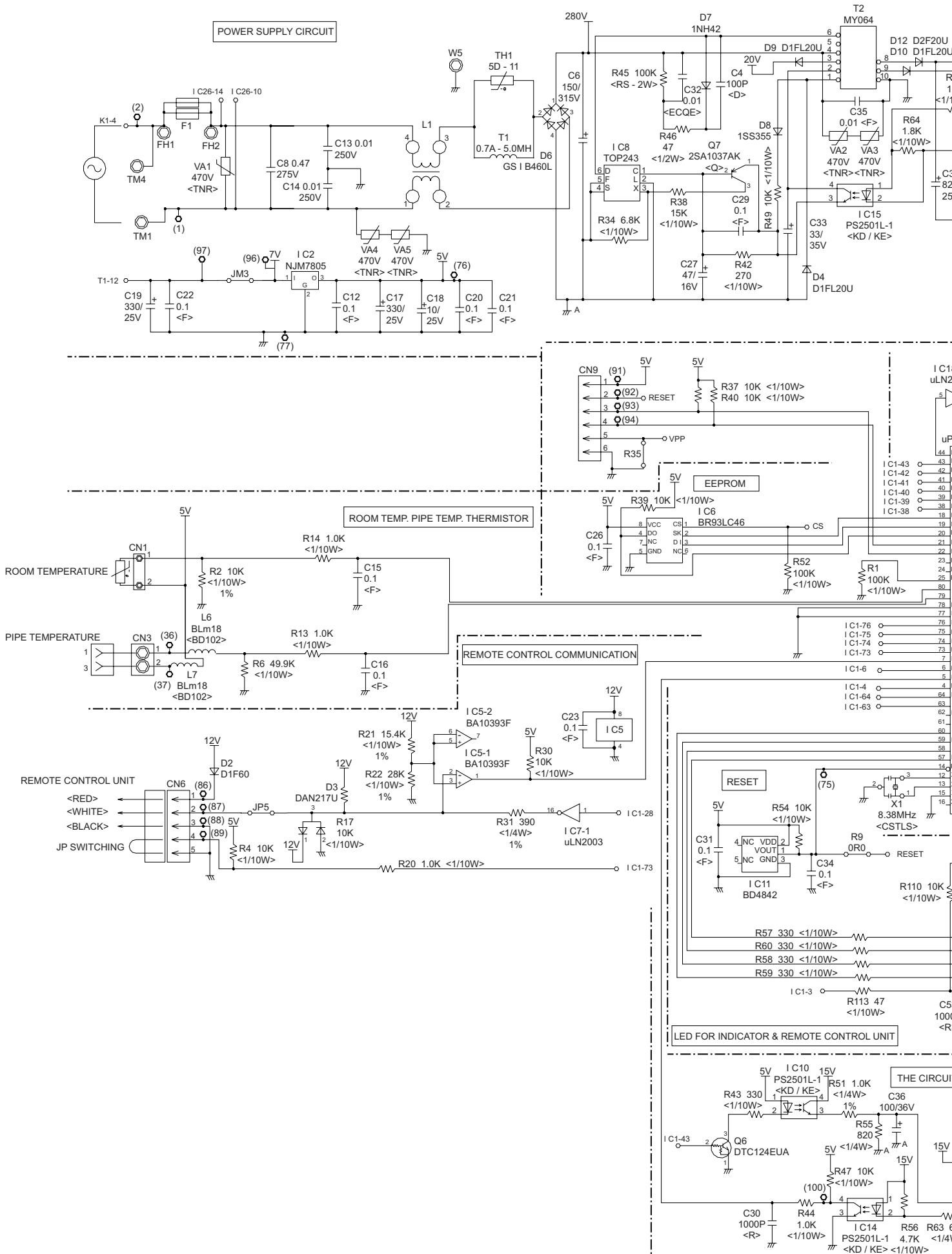

Model : MW30C3F

INDICATOR PCB ASSY K05CY-0500HSE-D0

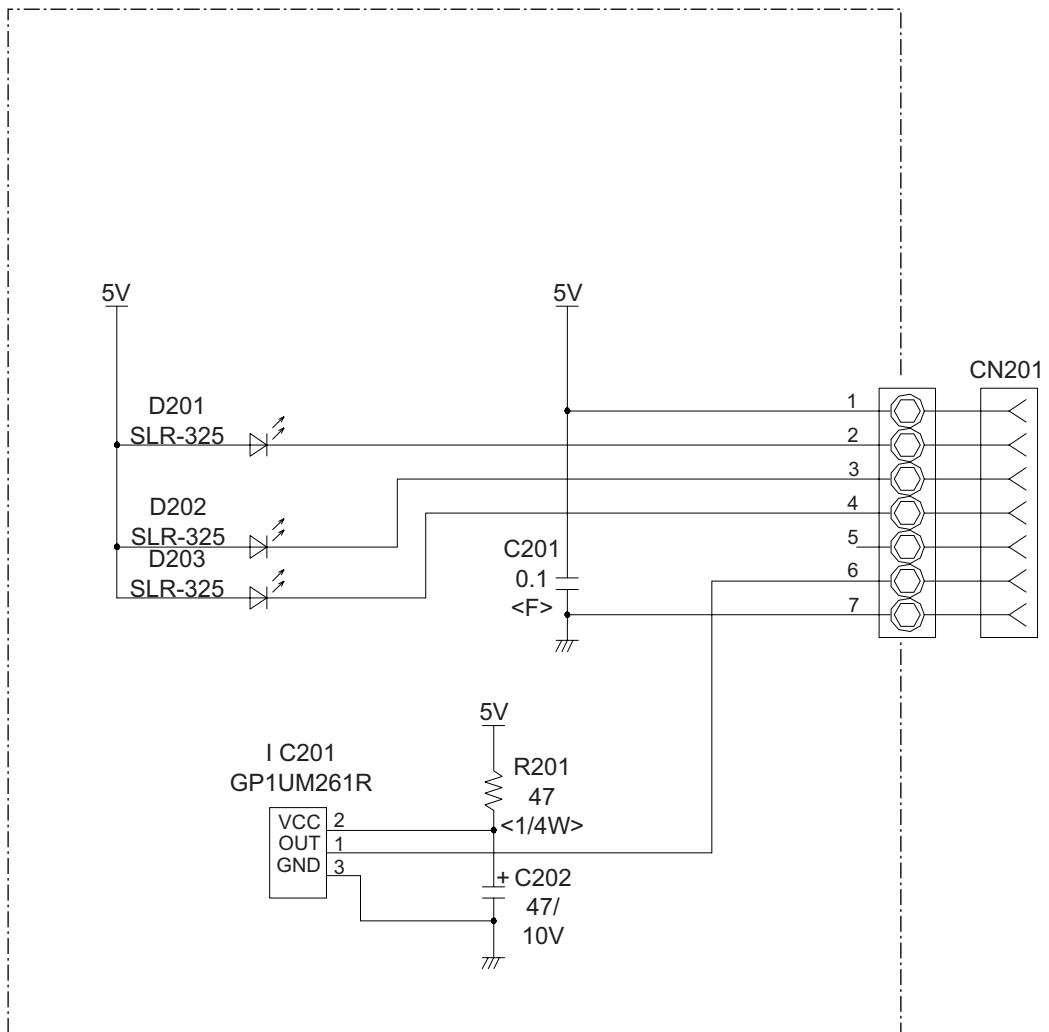

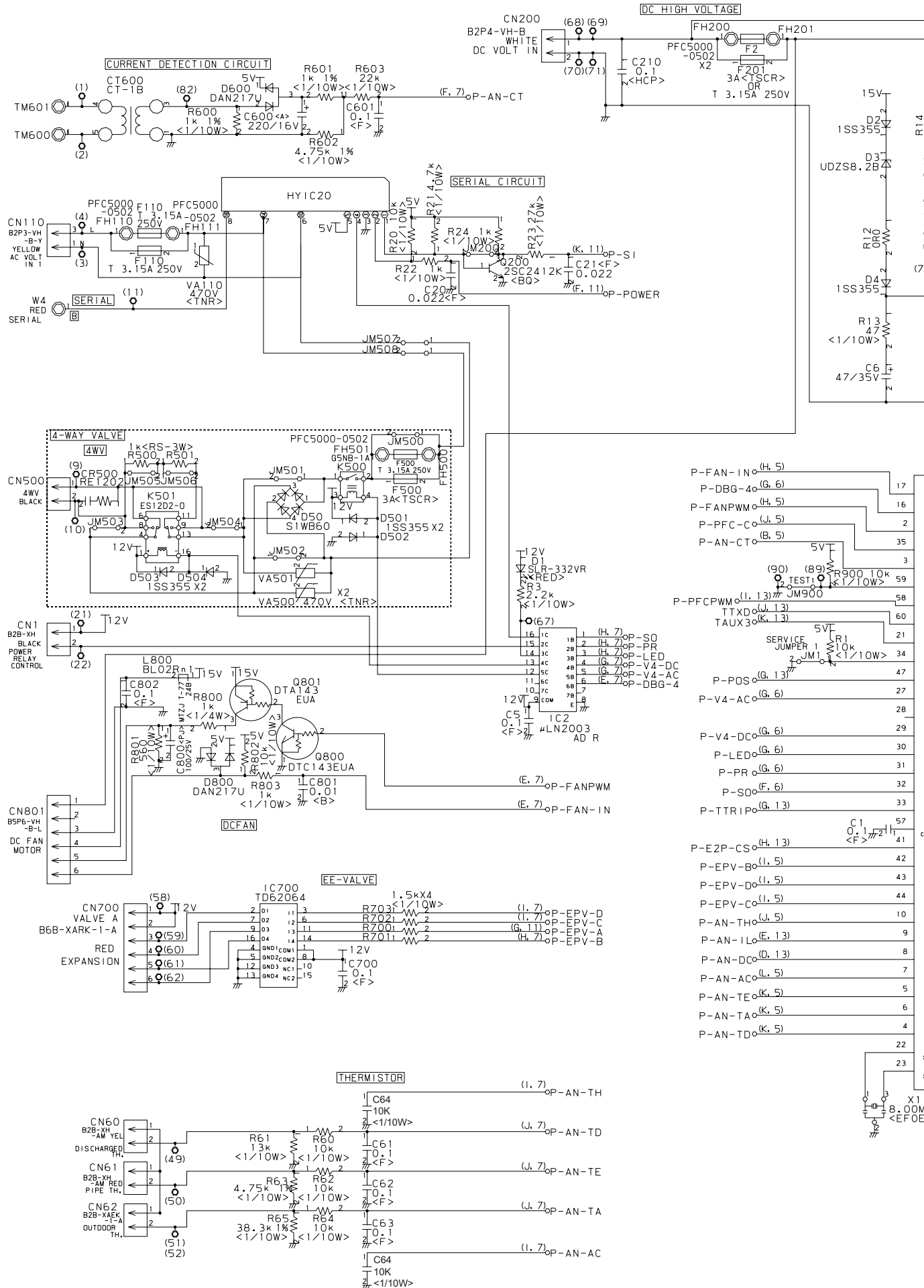

Model : MR30C3F

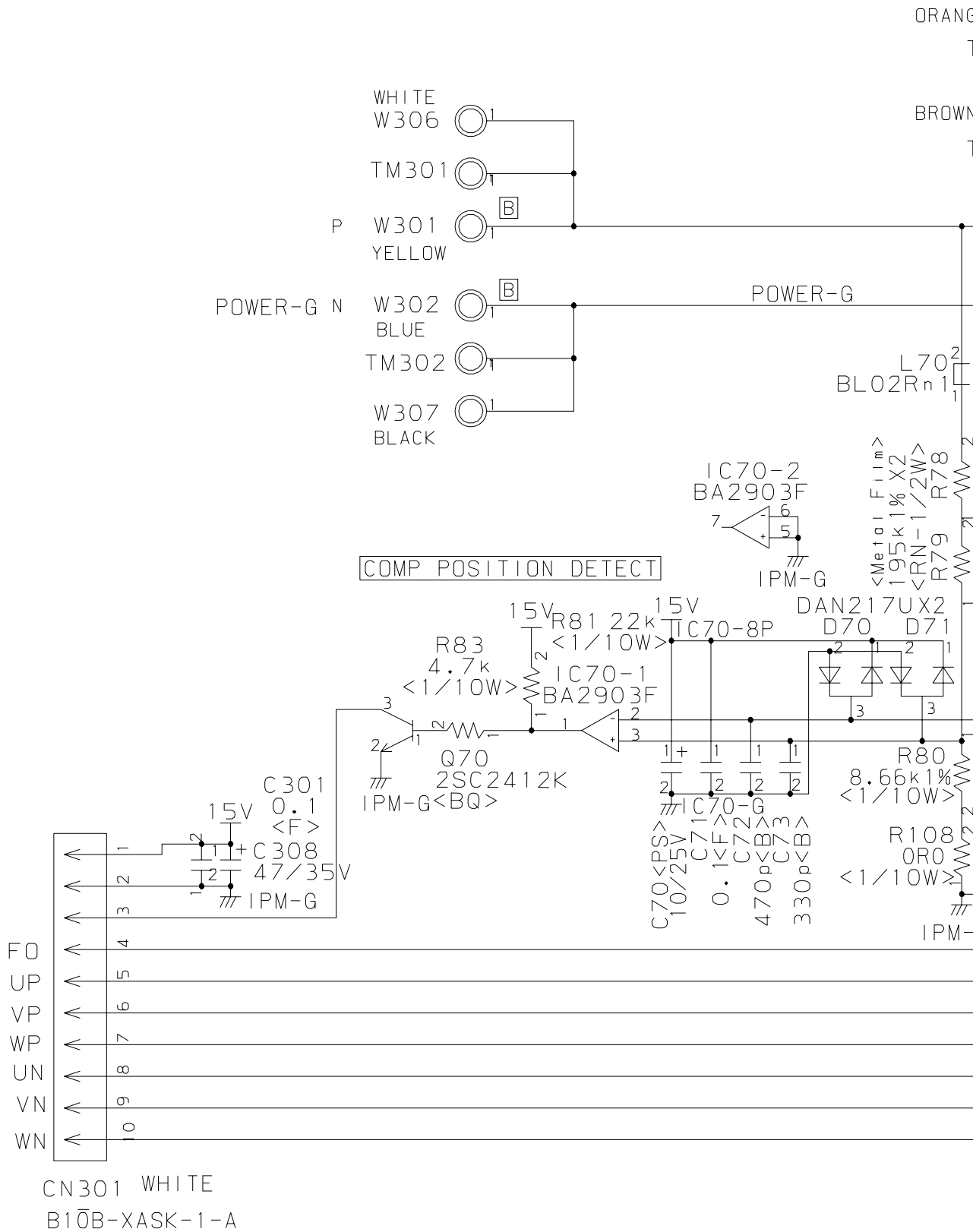

Model : MR30C3F

POWER SUPPLY PCB K05CW-0503HUE-FL0

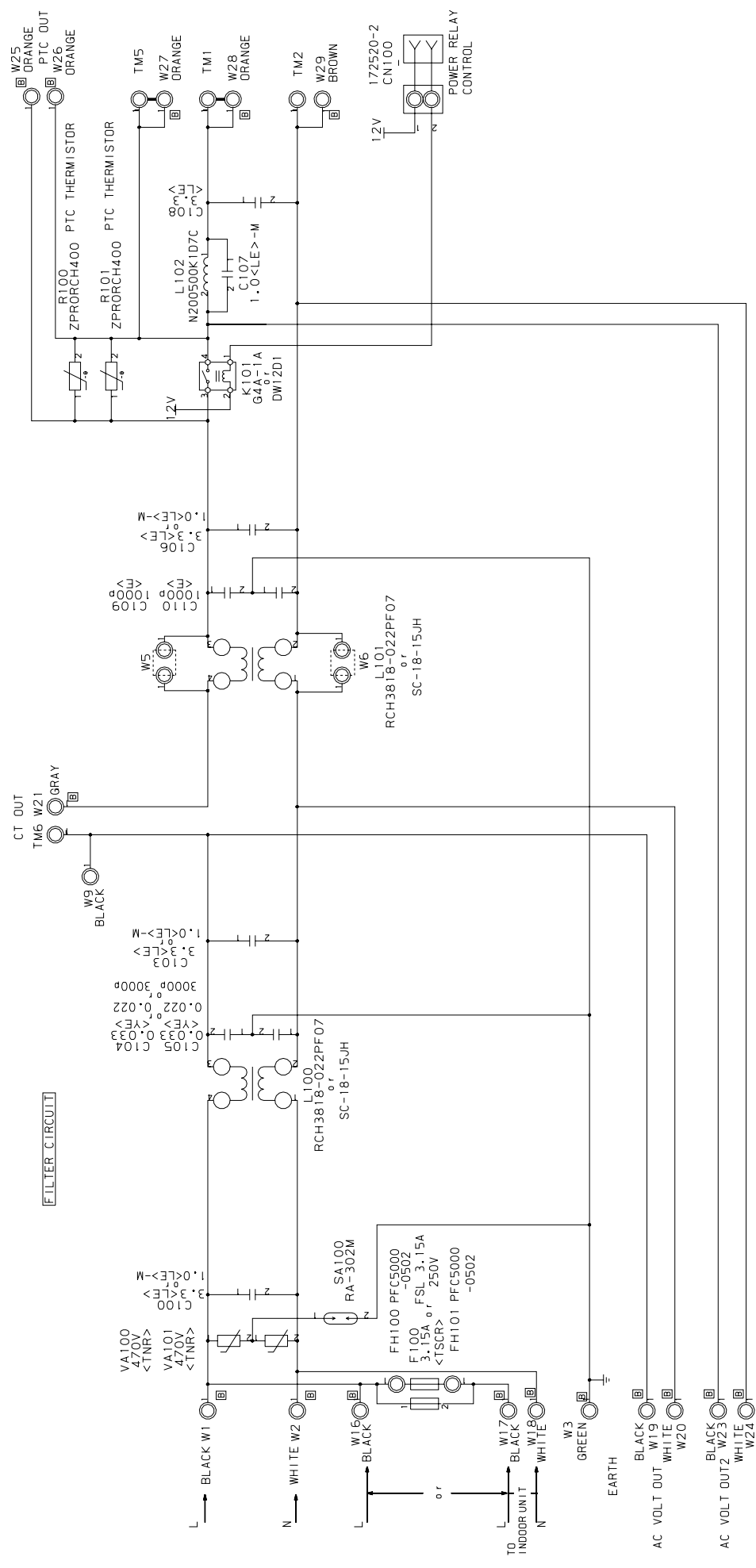

Model : MR30C3F

CAPACITOR PCB ASSEMBLY K05FB-0500HUE-P0

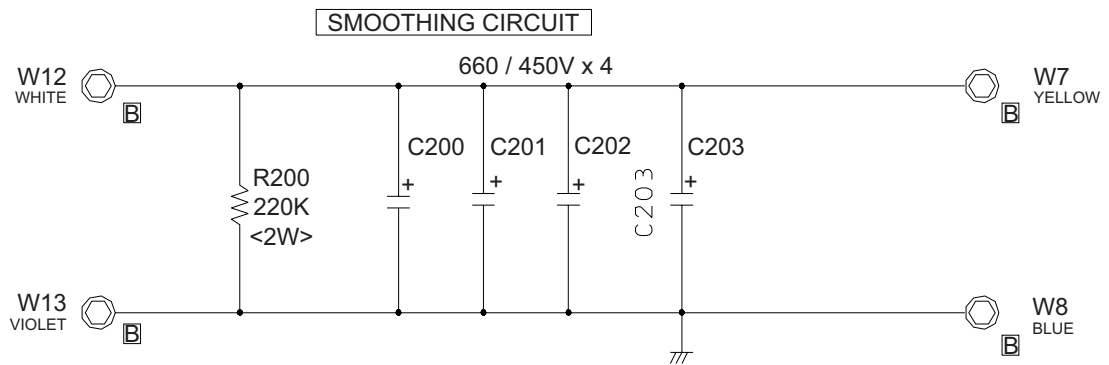

ERROR CONTENTS

Error	Display		Error
	Operation LED	Timer LED	
Serial signal error	Normal	2 flash	Serial signal (reverse) error, at operation start up
		3 flash	Serial signal (reverse) error, during operation
		4 flash	Serial signal (forward) error, at operation start up
		5 flash	Serial signal (forward) error, during operation
		8 flash	Wired remote controller error
Indoor unit thermistor error	2 flash	2 flash	Indoor temperature thermistor open / short
		3 flash	Heat exchanger middle thermistor open / short
Outdoor unit thermistor error	3 flash	2 flash	Discharge thermistor open / short
		3 flash	Heat exchanger thermistor open
		4 flash	Outdoor temperature thermistor open / short
		8 flash	Compressor temperature thermistor open / short
Indoor unit control error	4 flash	2 flash	Forced automatic SW welded
		3 flash	Main relay welded
		4 flash	Power interruption error
		7 flash	VDD permanent stop protection
		8 flash	reverse VDD permanent stop protection
Outdoor unit control error	5 flash	2 flash	Current trip error
		3 flash	CT abnormal
		5 flash	Compressor location detection error
		6 flash	Outdoor unit fan drive system abnormal
Indoor fan motor error	6 flash	2 flash	Abnormal lock
		3 flash	Abnormal rotation
Refrigerant cycle error	7 flash	2 flash	Discharge Temperature abnormal
		3 flash	Cooling high pressure abnormal rise
		5 flash	Pressure switch trouble
Optional function error	8 flash	2 flash	Active filter voltage trouble (second time)
		3 flash	Active filter voltage trouble (first time)
		4 flash	PFC circuit error
Model information error	0.1 sec on/off	0.1 sec on/off	Model information error

DISASSEMBLY ILLUSTRATION

Model : MW30C3F

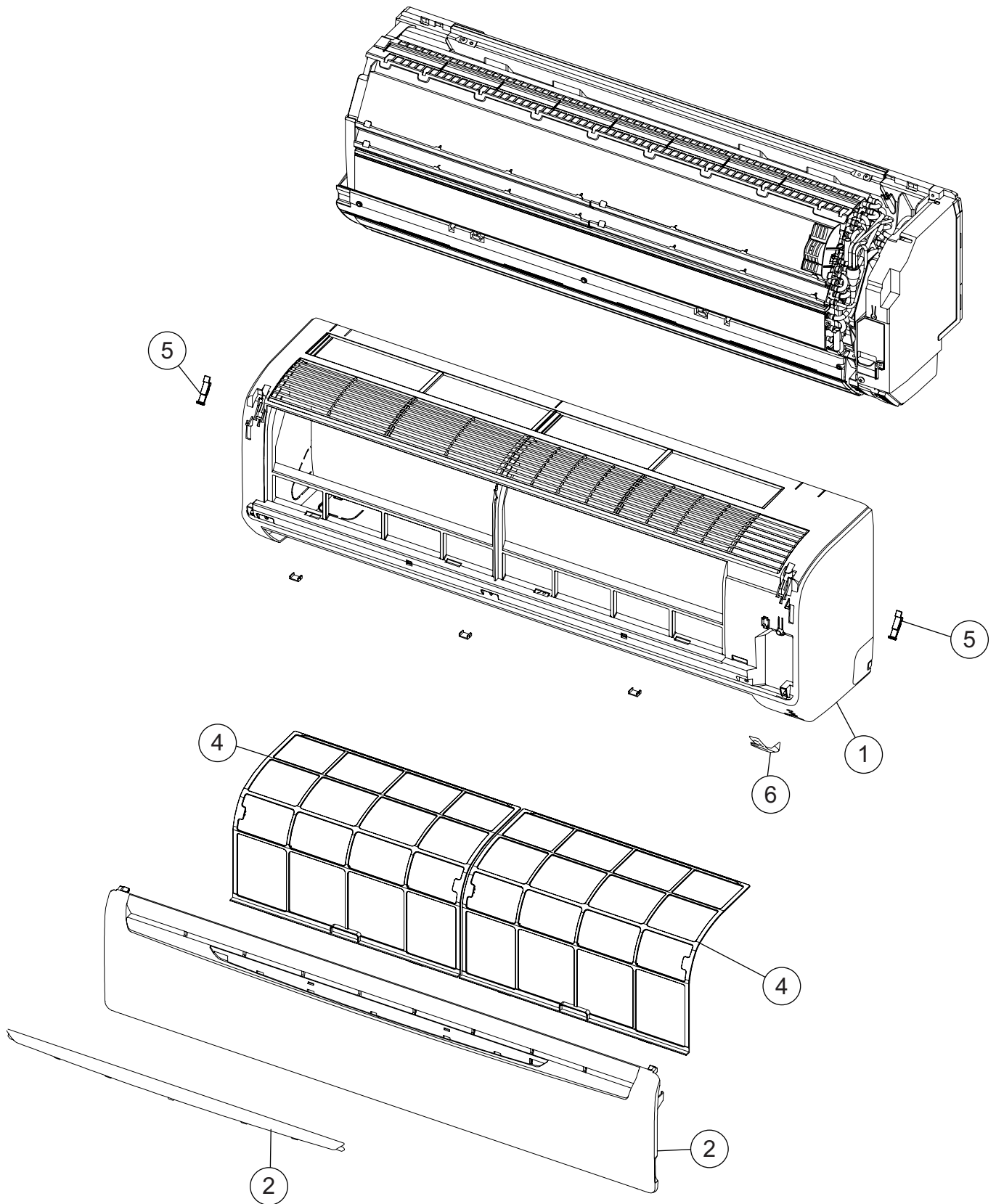

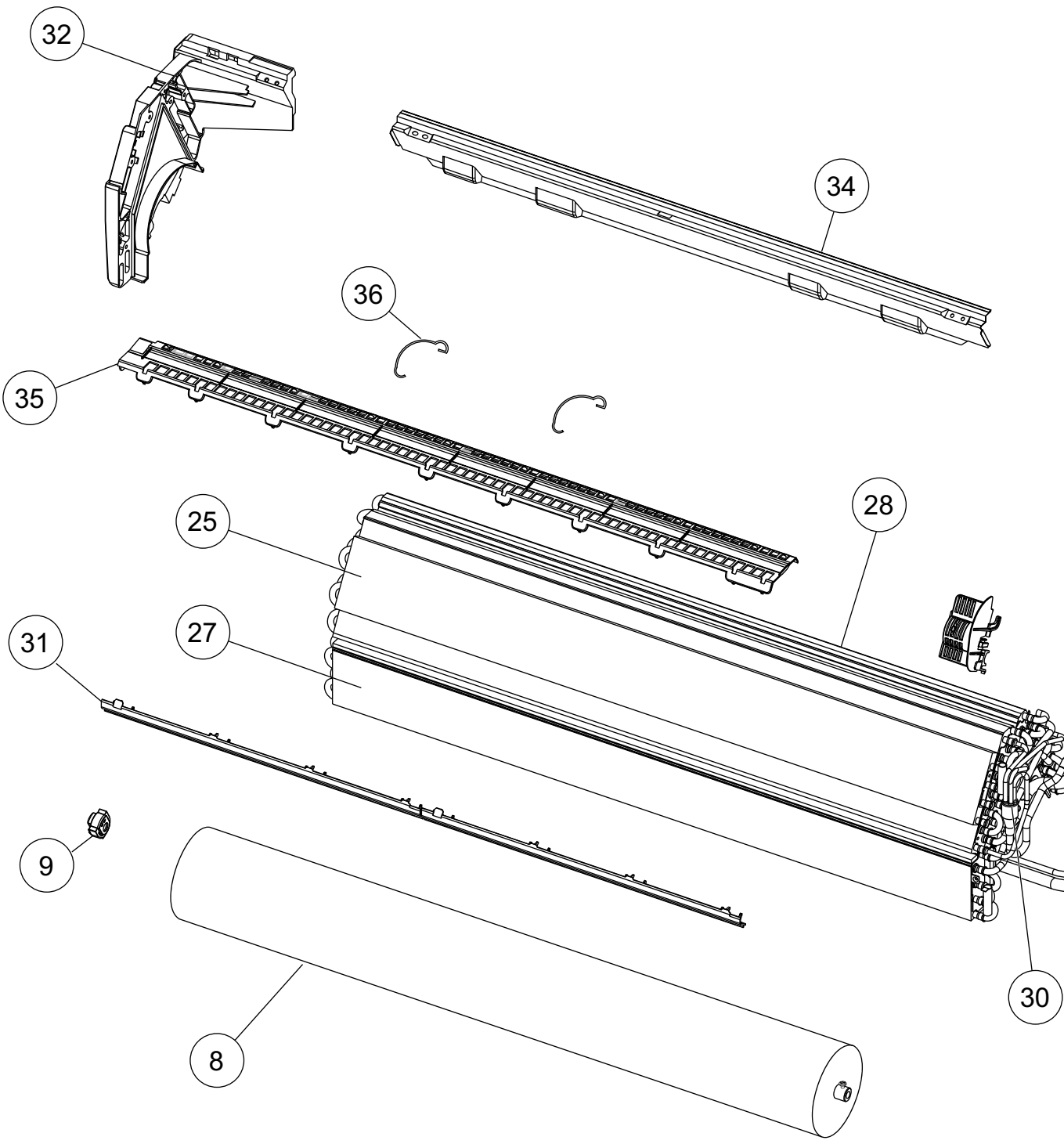

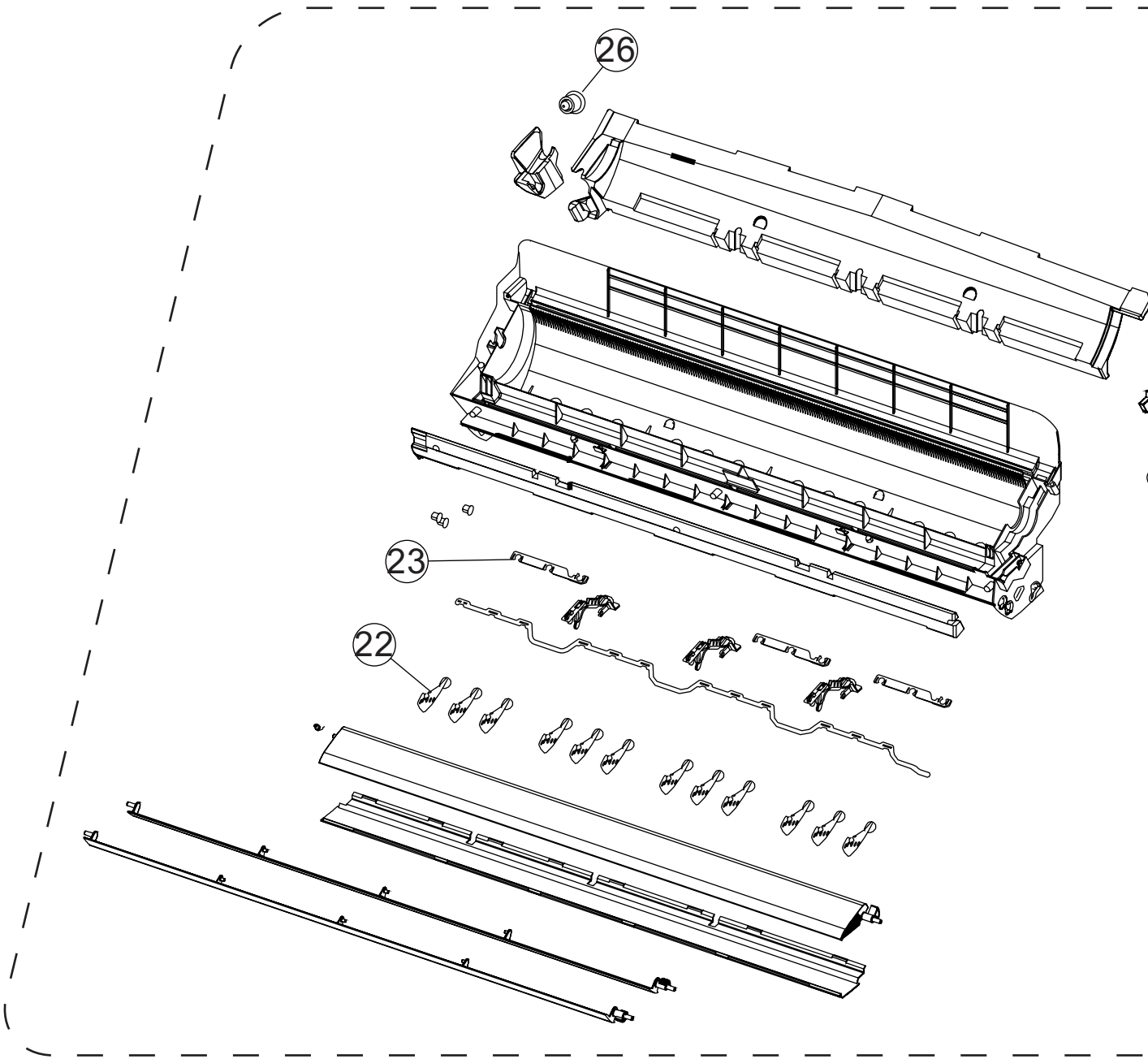

Model : MW30C3F

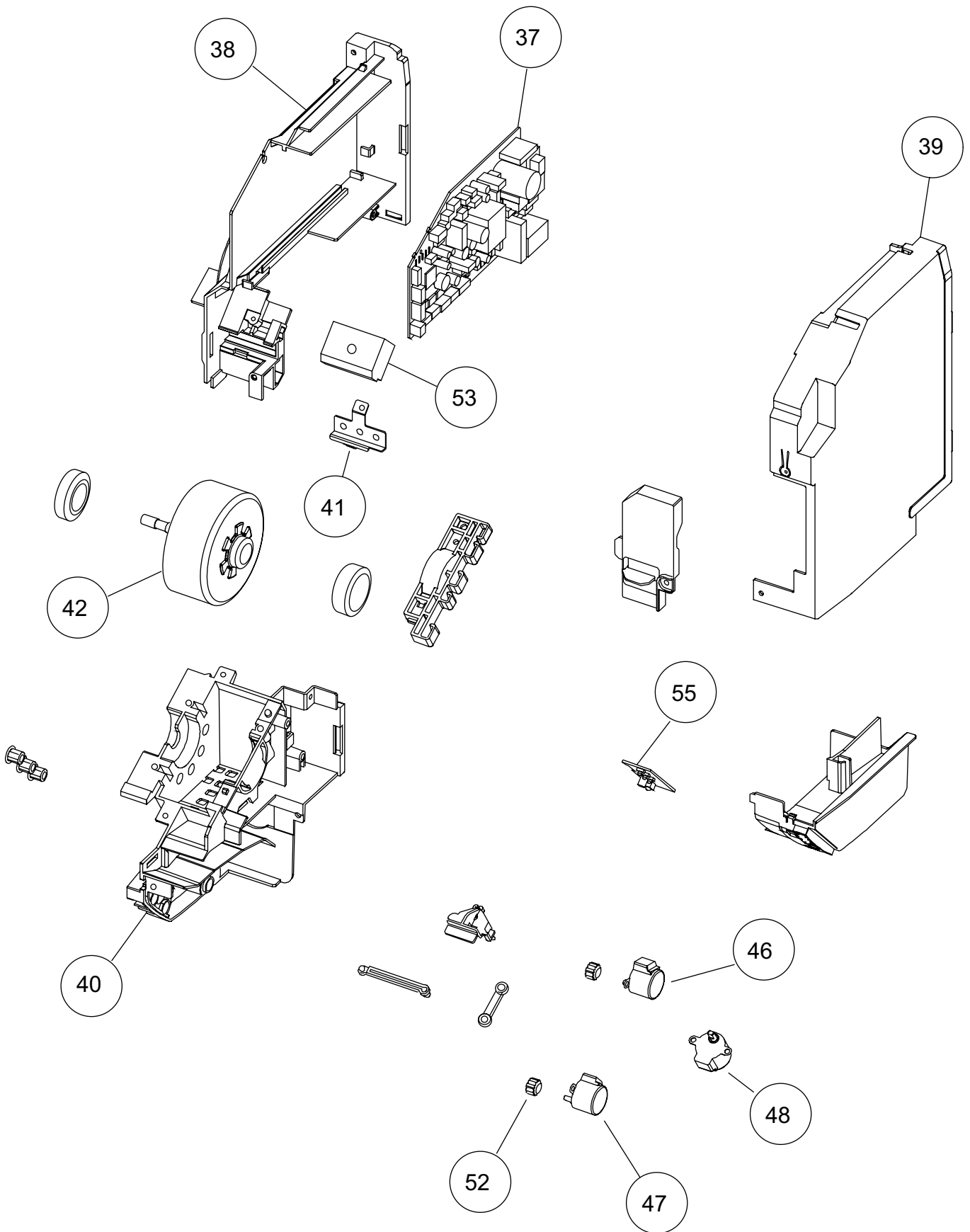

Model : MR30C3F

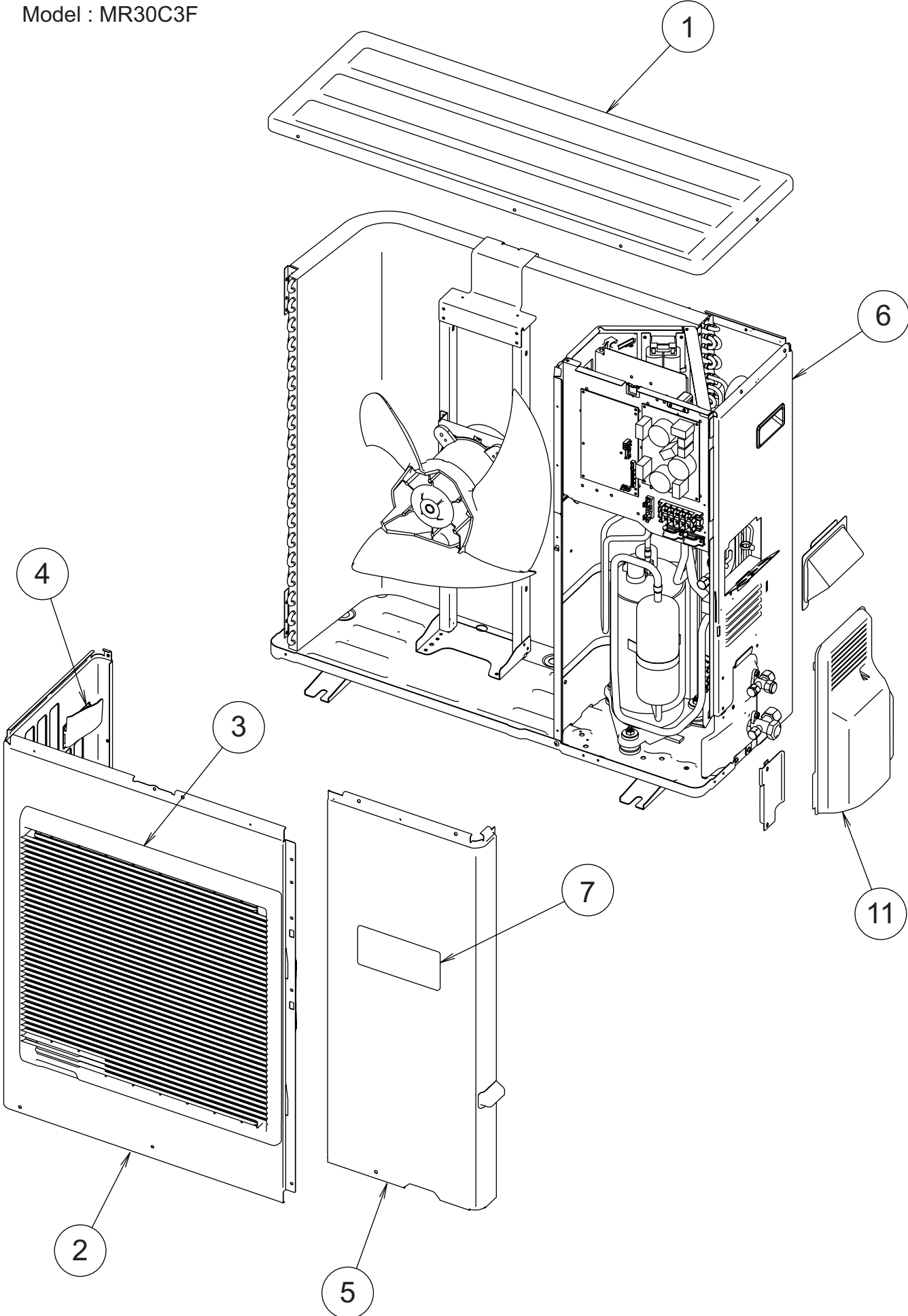

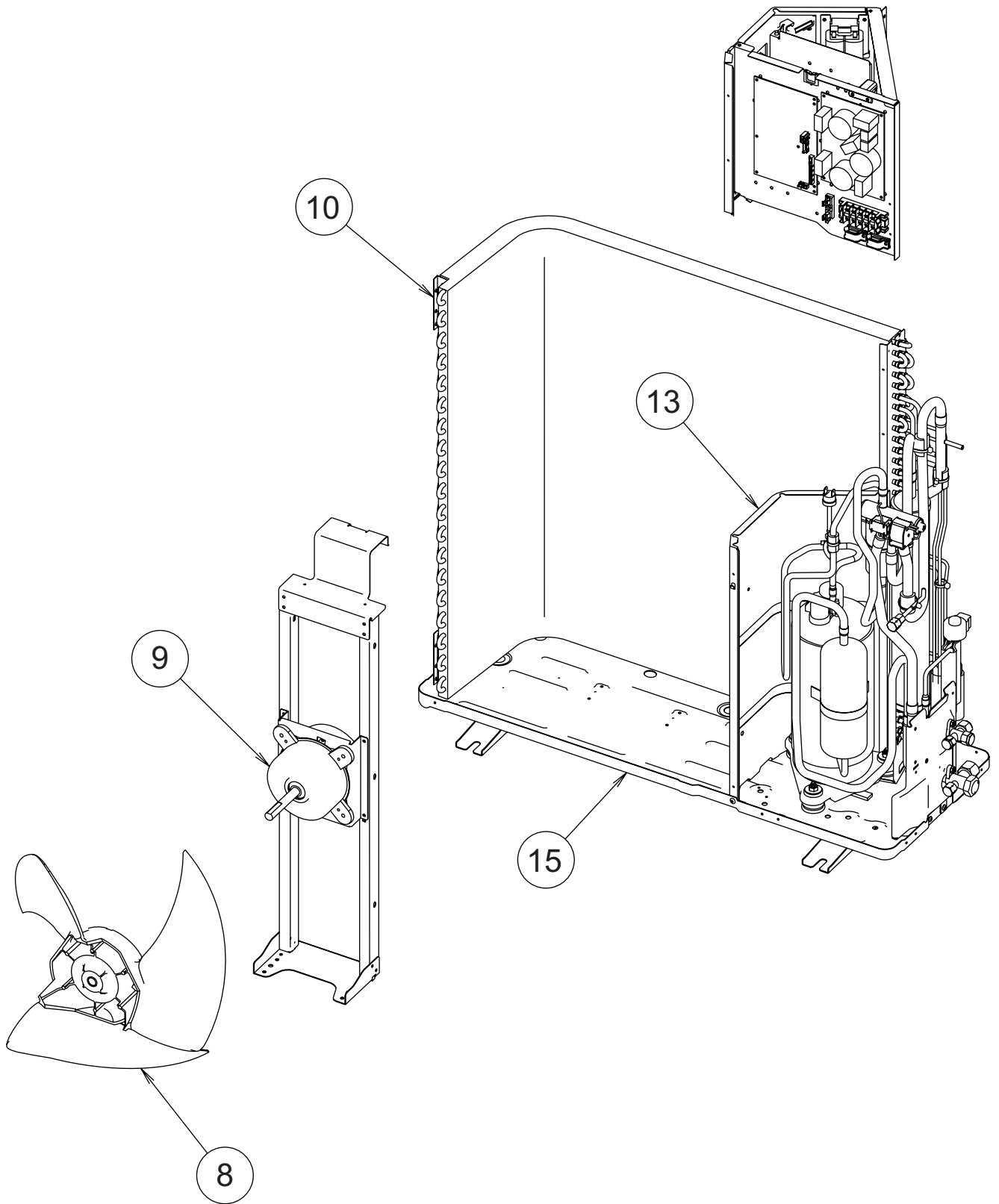

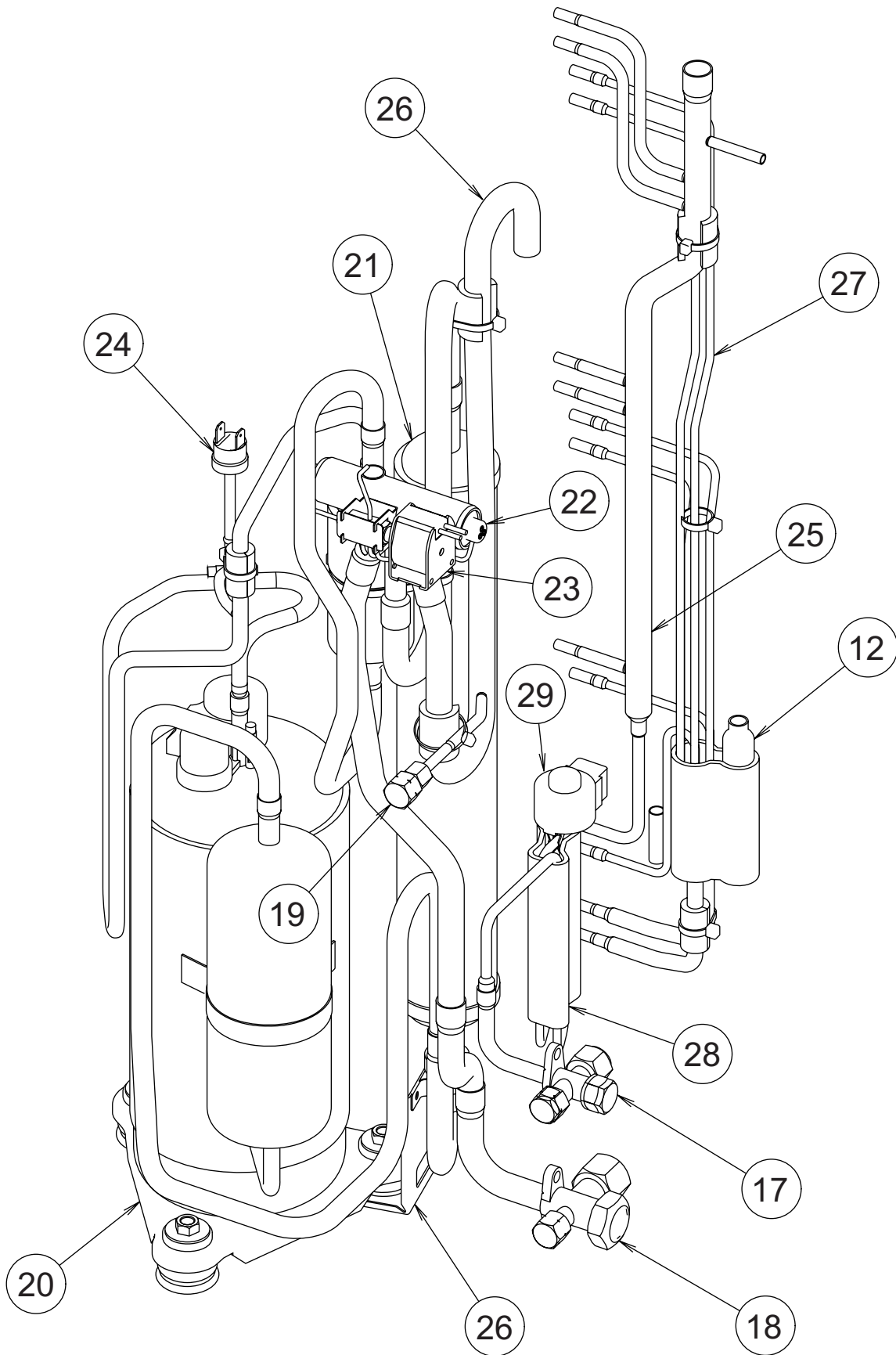

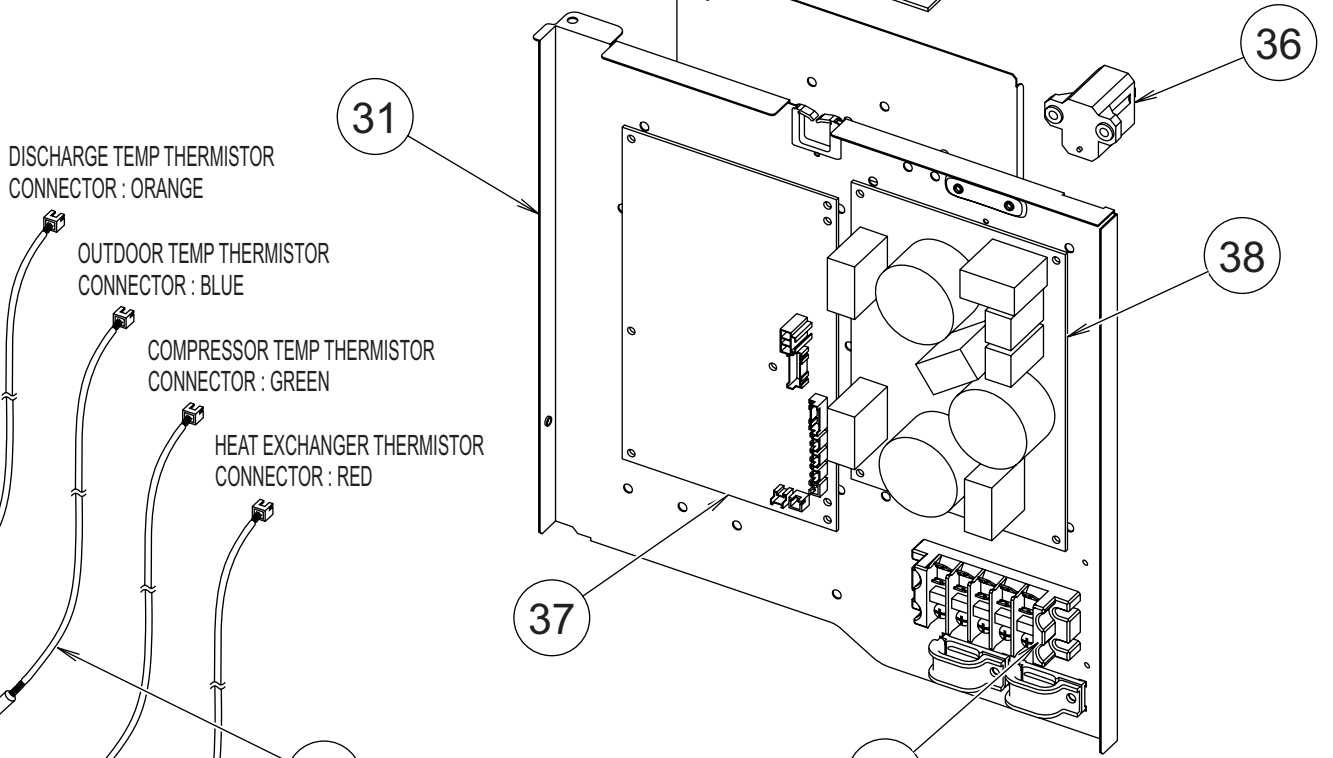
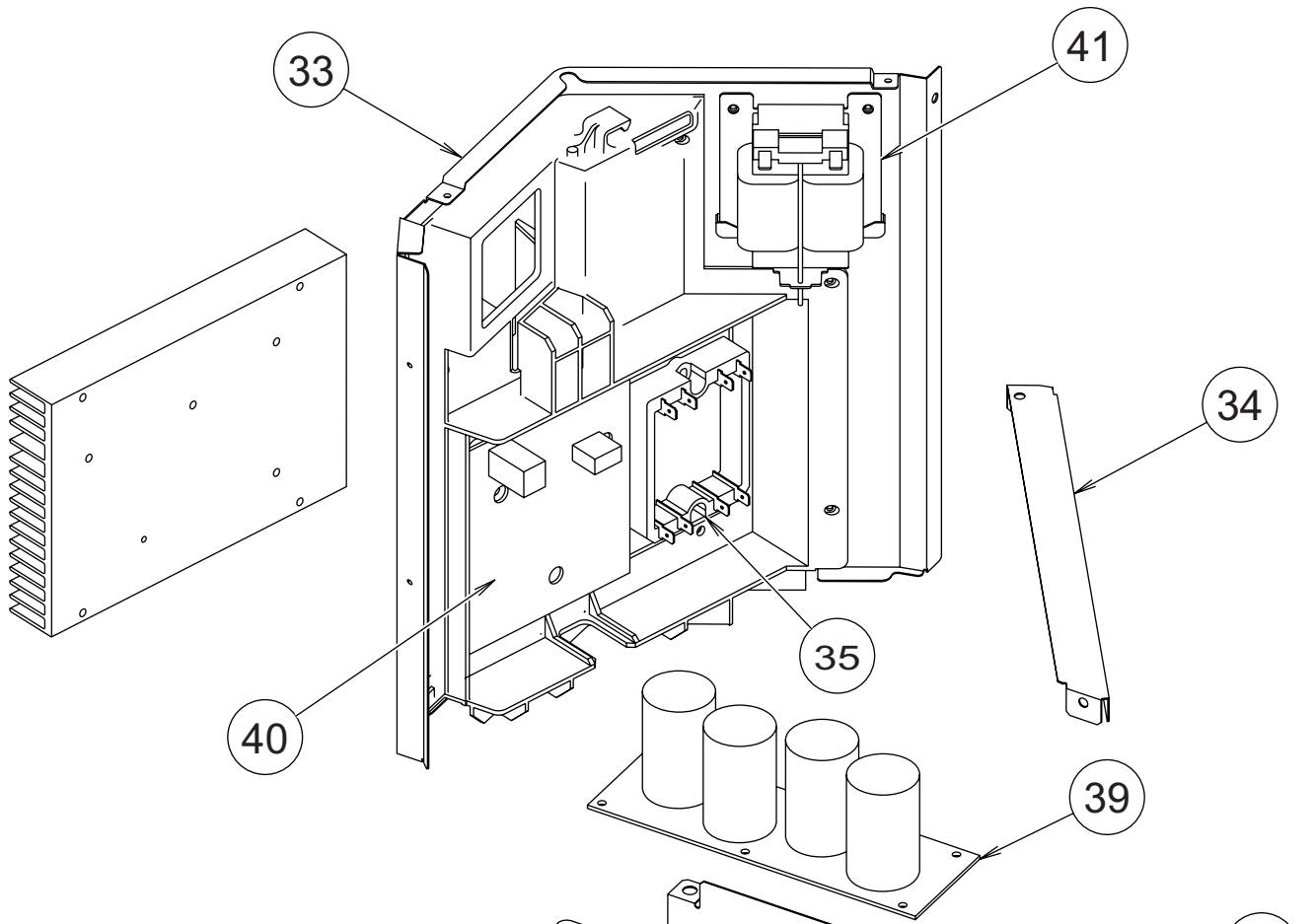

DISCHARGE TEMP THERMISTOR
CONNECTOR : ORANGE

OUTDOOR TEMP THERMISTOR
CONNECTOR : BLUE

COMPRESSOR TEMP THERMISTOR
CONNECTOR : GREEN

HEAT EXCHANGER THERMISTOR
CONNECTOR : RED

PRESSURE SWITCH WIRE
CONNECTOR : RED



PARTS LIST







INDOOR UNIT

Ref. No	Description	Part No.	Ord. Q'ty
		MW30C3F	
1	FRONT PANEL TOTAL ASSY	67201500	
2	INTAKE GRILLE ASSY	67201501	
4	AIR FILTER	67201502	
5	CLAMPER(GRILLE)	67200936	
6	RECEIVER WINDOW	67201503	
8	CROSSFLOW FAN ASSY	67201504	
9	BEARING C ASSY	67200922	
10	CASING ASSY	67201505	
22	R AND L LOUVER	67201506	
23	SPACER B	67201507	
25	EVAPORATOR ASSY C	67201508	
26	DRAIN CAP	67201509	
27	EVAPORATOR ASSY	67201510	
28	EVAPORATOR ASSY B	67201511	
29	CONNECTION PIPE ASSY	67201512	
30	DISTRIBUTOR ASSY	67201513	
31	WATER SEAL	67201514	
32	EVAPORATER HOLDER R	67201515	
33	EVAPORATER HOLDER L	67201516	
34	REAR BRACKET	67201517	
35	FILTER GUIDE	67201518	
36	FILTER GUARD	67201519	
37	Controller PCB ASSY	67201520	
38	CONTROL BOX	67201521	
39	CONTROL COVER	67201522	
40	CASE(MOTOR)	67201523	
41	TERMINAL(EARTH)	67201524	
42	MOTOR,DC	67201525	
46	MOTOR,STEP	67201526	
47	MOTOR,STEP	67201527	
48	MOTOR,STEP	67201528	
52	GEAR A	67201206	
53	TERMINAL	67201529	
55	PWB ASSY(DISPLAY)	67201530	
.....	WALL HOOK BRACKET	67201531	
.....	REMOTE CONTROL	67201532	
.....	REMOTE CONTROL HOLDER	67201533	

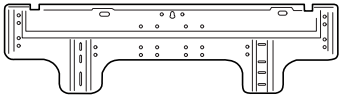
OUTDOOR UNIT

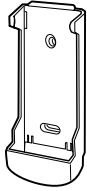
Ref. No	Description	Part No.	Ord. Q'ty
		MR30C3F	
1	TOP PANEL SUB ASSY	67201600	
2	FRONT PANEL M	67201601	
3	FAN GUARD	67201602	
4	HANDLE	67201603	
5	SERVICE PANEL SA	67201604	
6	RIGHT PANEL	67201605	
7	EMBLEM-REAR	67201606	
8	PROPELLER FAN ASSY	67201607	
9	MOTOR,DC	67201608	
10	CONDENSER A ASSY	67201609	
11	VALVE COVER	67201610	
12	STRAINER ASSY	67201611	
13	SEPARATE WALL W	67201612	
15	BASE AS PTD	67201613	
17	3-WAY VALVE ASSY	67201614	
18	3-WAY VALVE ASSY	67201615	
19	CHECK JOINT ASSY	67201616	
20	COMPRESSOR ASSY	67201617	
21	ACCUMULATOR	67201618	
22	4-WAY VALVE	67201619	
23	SOLENOID	67201620	
24	PRESSURE SWITCH	67201621	
25	INLET PIPE(COND)A ASSY	67201622	
26	ACCUMULATOR SUPPORT ASSY	67220154	
27	OUTLET PIPE(COND)A ASSY	67201623	
28	EXPANSION VALVE ASSY	67201624	
29	COIL(EXPANSION VALVE)	67201422	
31	CASE(PWB)AS	67201625	
33	CASE(INVERTER)	67201626	
35	ACTPM	67201627	
36	THERMISTOR	67201628	
37	PWB ASSY	67201629	
38	PWB ASSY	67201630	
39	PWB ASSY	67201631	
40	TR PWB ASSY	67201632	
41	COIL,CHOKE	67201633	
42	TERMINAL	67201634	
45	DISCHARG TEMP THERMISTOR	67201635	
46	THERMISTOR(OUTDOOR TEMP)	67201636	
47	COMPRESSOR TEMP THERMIST	67201637	
48	HEAT EXCHANGER THERMISTO	67201638	

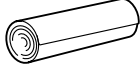
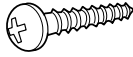
STANDARD ACCESSORIES

Name and Shape	Part No.
Wall hook bracket 	9315023018
Remote control unit 	9315027160
Remote control unit holder 	9305642045
Battery (penlight) 	0600185534
Cloth tape 	9310519004
Tapping screw (big) 	0700076046
Tapping screw (small) 	0700019036

0602G3030