

This Owner's Manual is provided and hosted by [Appliance Factory Parts](#).



FRIEDRICH CP18C30 Owner's Manual

[Shop genuine replacement parts for FRIEDRICH
CP18C30](#)



[Find Your FRIEDRICH Air Conditioner Parts - Select From 1575 Models](#)

----- Manual continues below -----



Service & Parts Manual

2007

Compact Programmable

Models

CP14N10

CP18N30

CP24N30

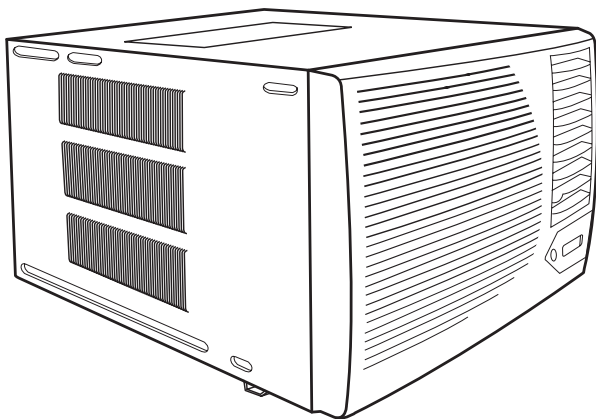

Table of Contents

Performance Data.....	3
Outer Component Identification.....	4
Installation Dimensions	5
Wiring Diagrams.....	6
Functional Component Definitions	7
Refrigeration System Sequence of Operation	8
Sealed Refrigeration System Repairs	9-12
Troubleshooting	13-18
Part Diagrams and Part Lists.....	19-23
Warranty	24



The information contained in this manual is intended for use by a qualified service technician who is familiar with the safety procedures required in installation and repair, and who is equipped with the proper tools and test instruments.

Installation or repairs made by unqualified persons can result in hazards subjecting the unqualified person making such repairs to the risk of injury or electrical shock which can be serious or even fatal not only to them, but also to persons being served by the equipment.

If you install or perform service on equipment, you must assume responsibility for any bodily injury or property damage which may result to you or others. Friedrich Air Conditioning Company will not be responsible for any injury or property damage arising from improper installation, service, and/or service procedures.

Specifications and Technical Parameters

Model	CP14N10	CP18N30	CP24N30	
Function	COOLING	COOLING	COOLING	
Rated Voltage	115V ~	230/208V~	230/208V~	
Rated Frequency	60Hz	60Hz	60Hz	
Total Capacity (Btu/h)	14000	18000/17600	23500/23100	
Power Input (W)	1430	1850/1810	2740/2710	
Rated Input (W)	1540	2478	3538	
Rated Current (A)	15	12.57	18.09	
Air Flow Volume (CFM) (H)	458.8	458.8	617.6	
Dehumidifying Volume (pints/h)	3.38	4.65	8.46	
EER / C.O.P BTU/W.H)	9.8	9.7/9.7	8.6/8.5	
Energy Class	/	/	/	
Indoor Side	Fan Type-Piece	Centrifugal flow fan – 1	Centrifugal flow fan – 1	Centrifugal flow fan – 1
	Diameter-Length (inch)	φ7.93 X 4.31	φ7.93 X 4.31	φ8.82 X 4.31
	Evaporator	Aluminum fin-copper tube	Aluminum fin-copper tube	Aluminum fin-copper tube
	Pipe Diameter (inch)	φ0.276	φ0.276	φ0.276
Coil length (l) x height (H) x coil width (L)		16.61 X 15 X 1	16.61 X 15 X 1	16.61 X 15 X 1
Outdoor Side	Compressor Type	ROTARY	ROTARY	ROTARY
	L.R.A. (A)	58	42	56
	Compressor RLA(A)	10.9	7.45	11.7/11.0
	Compressor Power Input(W)	1182	1700	2425/2480
	Overload Protector	MRA13425-12007	MRA98982-9200	Built in
	Working Temp Range (°F)	50°-115°	50°-115°	50°-115°
	Condenser	Aluminum fin-copper tube	Aluminum fin-copper tube	Aluminum fin-copper tube
	Fan Type-Piece	Axial fan –1	Axial fan –1	Axial fan –1
Fan Diameter (inch)		φ15.59	φ15.59	φ15.59
Fan Motor Speed (rpm) (H/M/L)		900/780/730	900/780/730	1000/900/800
Output of Fan Motor (W)		200	200	190
Fan Motor RLA(A)		3	1.45	1.35
Fan Motor Capacitor (uF)		15 MFD	7 MFD	7 MFD
Permissible Excessive Operating Pressure for the Discharge Side (Psig)		300	300	300
Permissible Excessive Operating Pressure for the Suction Side (Psig)		150	150	150
Dimension (H/W/D)(inch)		16.85 x 25.98 x 28.46	16.85 x 25.98 x 28.46	16.85 x 25.98 x 29.29
Dimension of Package (H/W/D)(inch)		19.96 x 31.1 x 29.13	19.96 x 31.1 x 29.13	19.69 x 29.29 x 36.22
Net Weight /Gross Weight (Pounds)		150/163	150/163	165/183
Refrigerant Charge (Ounce)		R22/26.46	R22/27.87	R22/33.51

Performance Data

PERFORMANCE DATA* Cooling	EVAP. AIR TEMP. DEG. F		CONDENSER TEMPERATURE DEG. F	Discharge Temp	Suction Temp	Super Heat	Sub-Cooling	OPERATING PRESSURES		ELECTRICAL RATINGS			R-22 REF. Charge in OZ.	Voltage	BREAKER FUSE 60 Hertz Amps
	Discharge Air	Temp. Drop F.						Suction	Discharge	Amps Cool	Amps Heat	Locked Rotor Amps			
CP14N10	59	21	118	173	56	41	54	78	267	12.1	/	58	26.5	115	15
CP18N30	58	22	119	173	66	52	55	77	269	8.3	/	38.9/42.4	27.9	230	15
	57	23	119	172	66	52	55	77	269	8.5	/			208	
CP24N30	57	23	117	197	60	44	50	75	264	12.3	/	56A(230V)	33.5	230	20
	56	24	117	195	57	44	50	75	264	13.1	/			208	

*Rating Conditions: 80 degrees F, room air temp. & 50% relative humidity, with 95 degree F, outside air temp & 40% relative humidity.

Outer Component Identification

Models: CP14N10, CP18N30, CP24N30

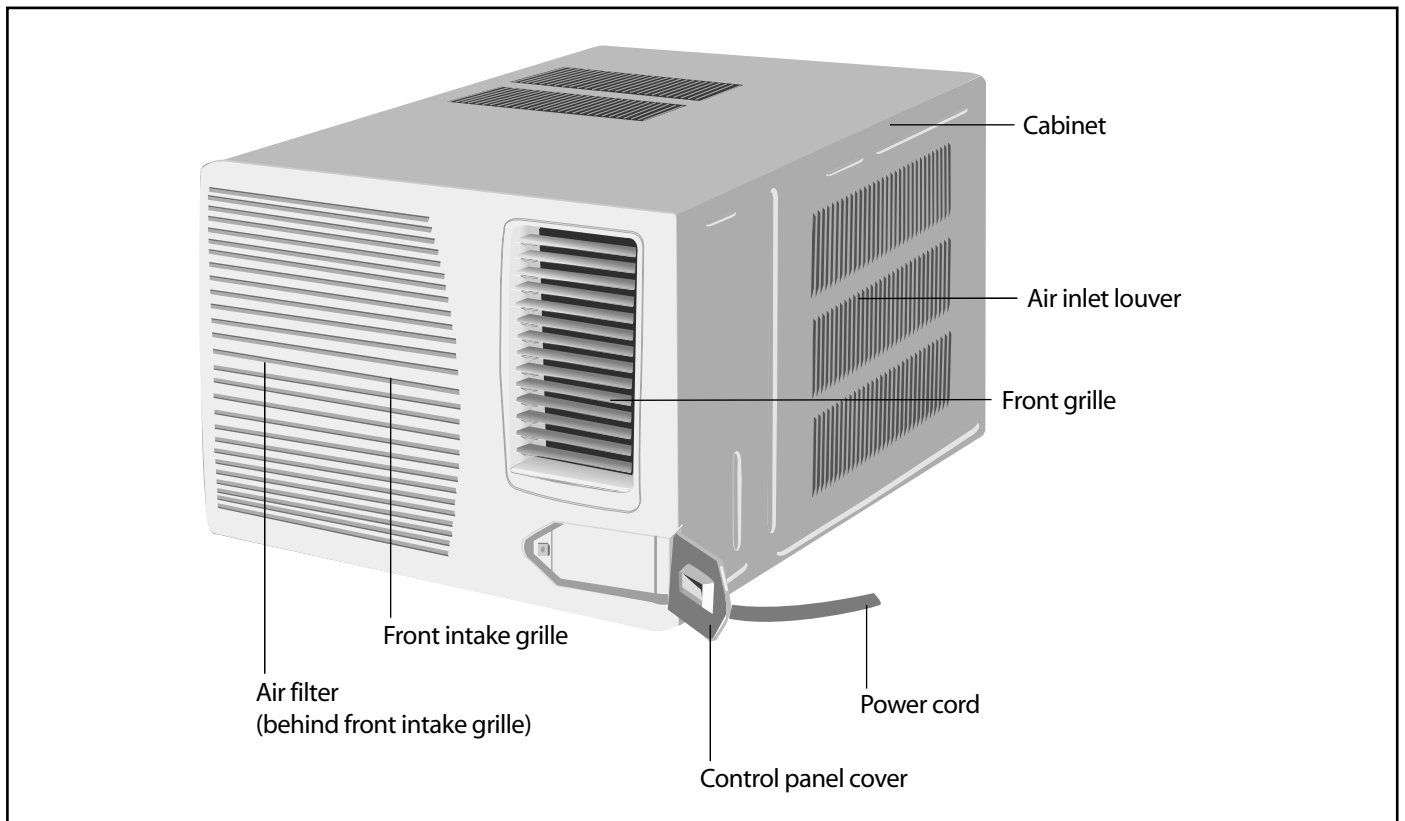

Installation Dimensions

Models: CP14N10, CP18N30, CP24N30

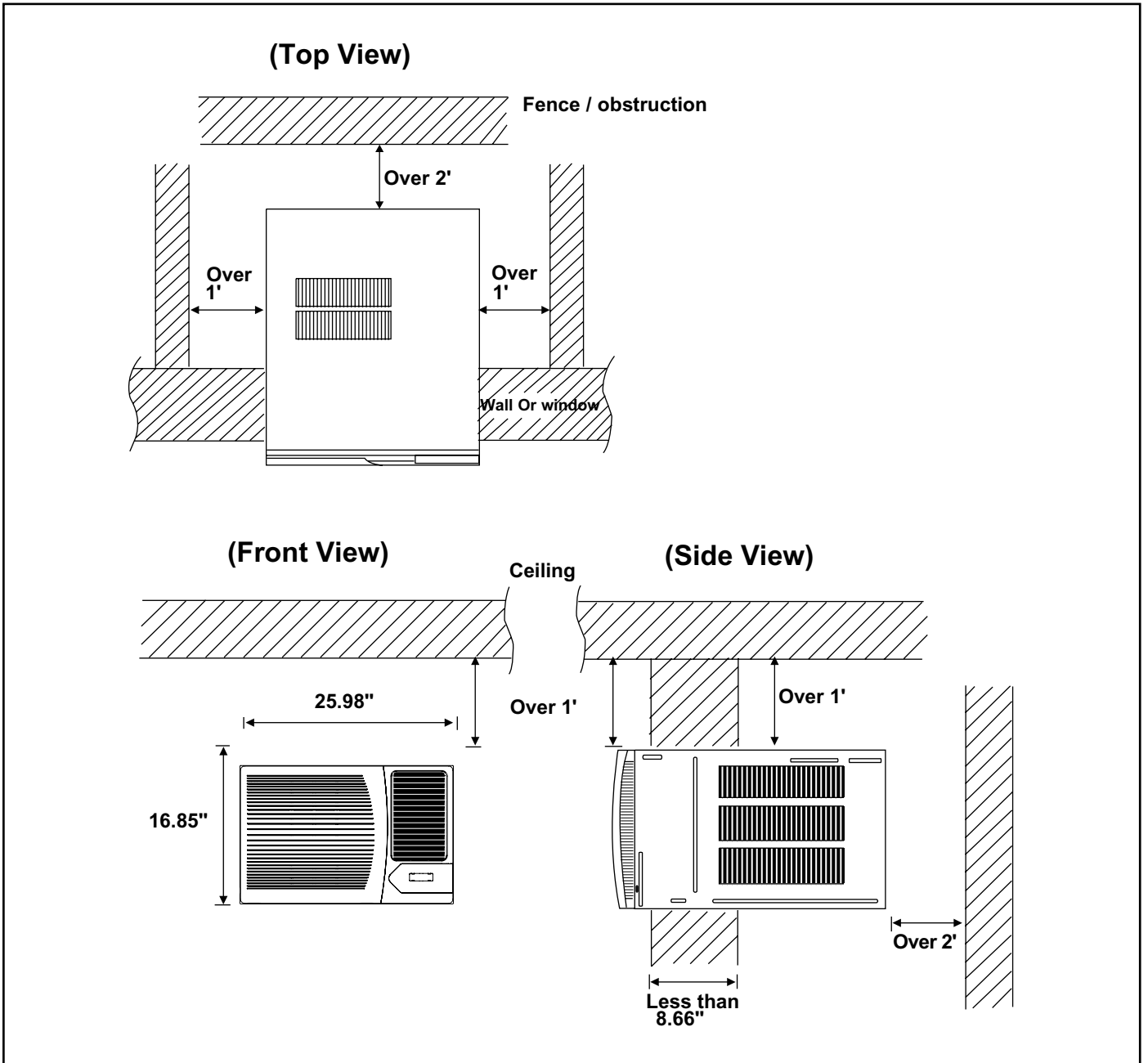

Wiring Diagrams

CP24N30

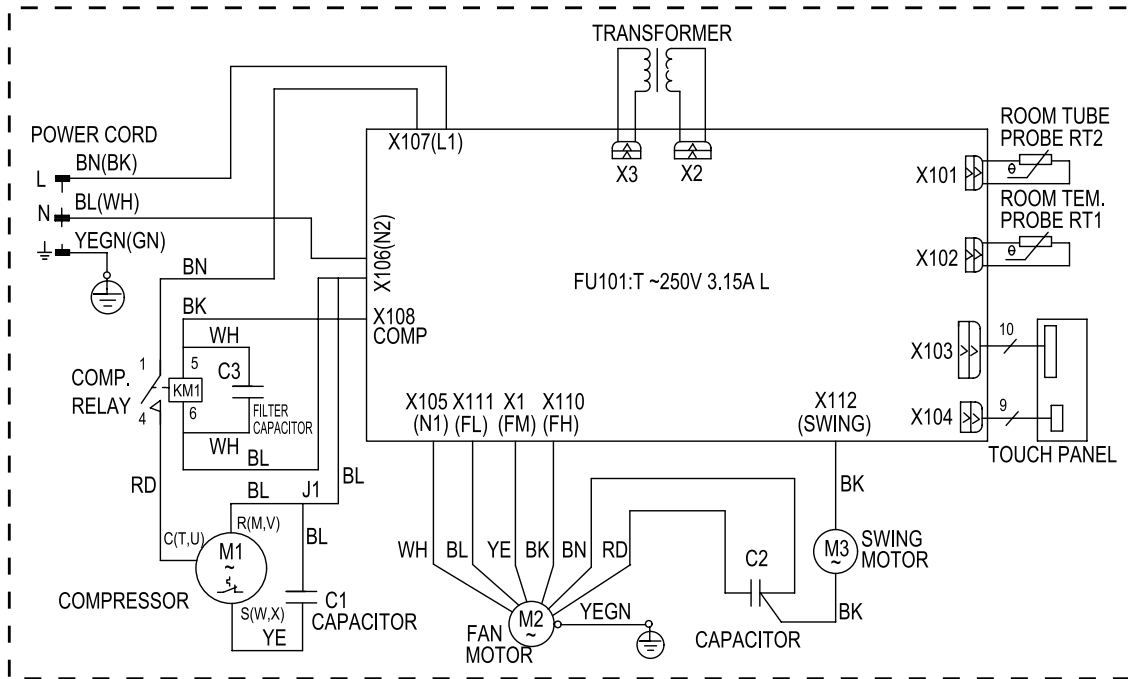

CP18N30 / CP14N10

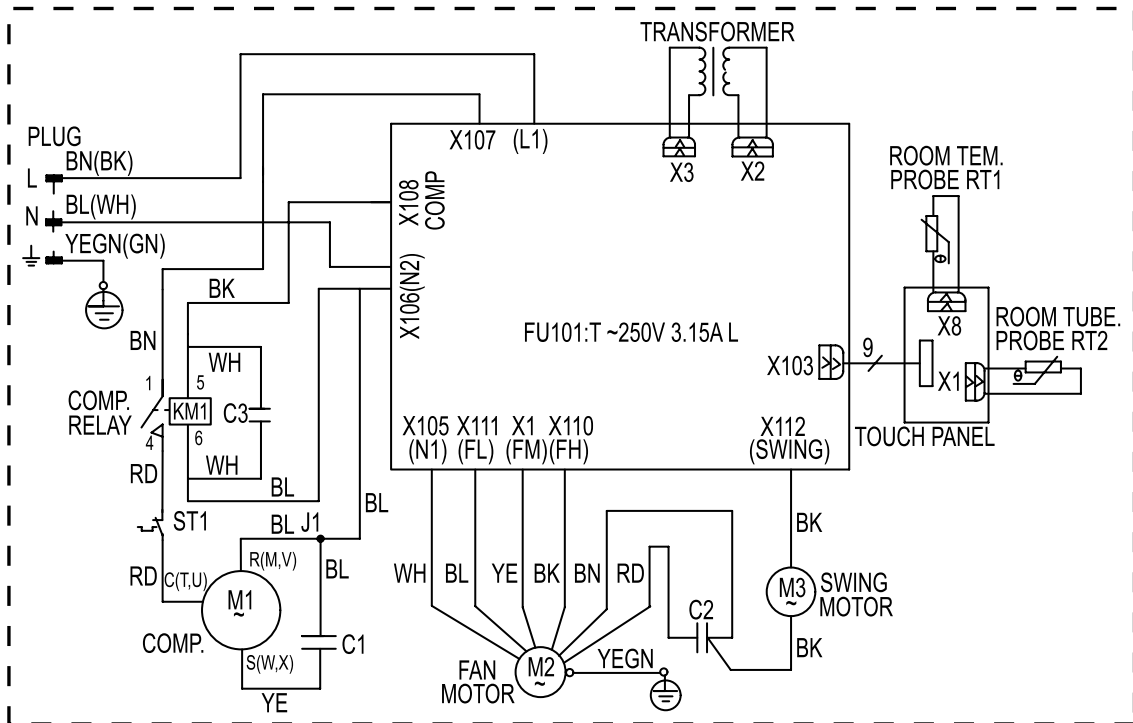

Functional Component Definitions

MECHANICAL COMPONENTS

Vent door Allows introduction of fresh air into the room and/or exhausts stale room air outside (on select models.)

Plenum assembly Diffuser with directional louvers used to direct the conditioned airflow.

Blower wheel Attaches to the indoor side of the fan motor shaft and is used for distributing unconditioned, room side air through the heat exchanger and delivering conditioned air into the room.

Slinger fan blade Attaches to the outdoor side of the fan motor shaft and is used to move outside air through the condenser coil, while slinging condensate water out of the base pan and onto the condenser coil, thus lowering the temperature and pressures within the coil.

ELECTRICAL COMPONENTS

Thermostat Used to maintain the specified room side comfort level

Capacitor Reduces line current and steadies the voltage supply, while greatly improving the torque characteristics of the fan motor and compressor motor.

MoneySaver® switch When engaged, it sends the power supply to the fan motor through the thermostat, which allows for a cycle-fan operation.

Fan Motor Dual-shafted fan motor operates the indoor blower wheel and the condenser fan blade simultaneously.

Heat anticipator Used to provide better thermostat and room air temperature control.

HERMETIC COMPONENTS

Compressor Motorized device used to compress refrigerant through the sealed system.

Check valve A pressure-operated device used to direct the flow of refrigerant to the proper capillary tube, during either the heating or cooling cycle.

Capillary tube A cylindrical meter device used to evenly distribute the flow of refrigerant to the heat exchangers (coils.)

Refrigeration System Sequence of Operation

A good understanding of the basic operation of the refrigeration system is essential for the service technician. Without this understanding, accurate troubleshooting of refrigeration system problems will be more difficult and time consuming, if not (in some cases) entirely impossible. The refrigeration system uses four basic principles (laws) in its operation they are as follows:

1. "Heat always flows from a warmer body to a cooler body."
2. "Heat must be added to or removed from a substance before a change in state can occur"
3. "Flow is always from a higher pressure area to a lower pressure area."
4. "The temperature at which a liquid or gas changes state is dependent upon the pressure."

The refrigeration cycle begins at the compressor. Starting the compressor creates a low pressure in the suction line which draws refrigerant gas (vapor) into the compressor. The compressor then "compresses" this refrigerant, raising its pressure and its (heat intensity) Temperature.

The refrigerant leaves the compressor through the discharge line as a hot high pressure gas (vapor). The refrigerant enters the condenser coil where it gives up some of its heat. The condenser fan moving air across the coil's finned surface facilitates the transfer of heat from the refrigerant to the relatively cooler outdoor air.

When a sufficient quantity of heat has been removed from the refrigerant gas (vapor), the refrigerant will "condense" (i.e. change to a liquid). Once the refrigerant has been condensed (changed) to a liquid it is cooled even further by the air that continues to flow across the condenser coil.

The RAC design determines at exactly what point (in the condenser) the change of state (i.e. gas to a liquid) takes place. In all cases, however, the refrigerant must be totally condensed (changed) to a liquid before leaving the condenser coil.

The refrigerant leaves the condenser coil through the liquid line as a warm high pressure liquid. It next will pass through the refrigerant drier (if so equipped). It is the function of the drier to trap any moisture present in the system, contaminants, and large particulate matter.

The liquid refrigerant next enters the metering device. The metering device is a capillary tube. The purpose of the metering device is to "meter" (i.e. control or measure) the quantity of refrigerant entering the evaporator coil.

In the case of the capillary tube this is accomplished (by design) through size (and length) of device, and the pressure difference present across the device.

Since the evaporator coil is under a lower pressure (due to the suction created by the compressor) than the liquid line, the liquid refrigerant leaves the metering device entering the evaporator coil. As it enters the evaporator coil, the larger area and lower pressure allows the refrigerant to expand and lower its temperature (heat intensity). This expansion is often referred to as "boiling". Since the unit's blower is moving Indoor air across the finned surface of the evaporator coil, the expanding refrigerant absorbs some of that heat. This results in a lowering of the indoor air temperature, hence the "cooling" effect.

The expansion and absorbing of heat cause the liquid refrigerant to evaporate (i.e. change to a gas). Once the refrigerant has been evaporated (changed to a gas), it is heated even further by the air that continues to flow across the evaporator coil.

The particular system design determines at exactly what point (in the evaporator) the change of state (i.e. liquid to a gas) takes place. In all cases, however, the refrigerant must be totally evaporated (changed) to a gas before leaving the evaporator coil.

The low pressure (suction) created by the compressor causes the refrigerant to leave the evaporator through the suction line as a cool low pressure vapor. The refrigerant then returns to the compressor, where the cycle is repeated.

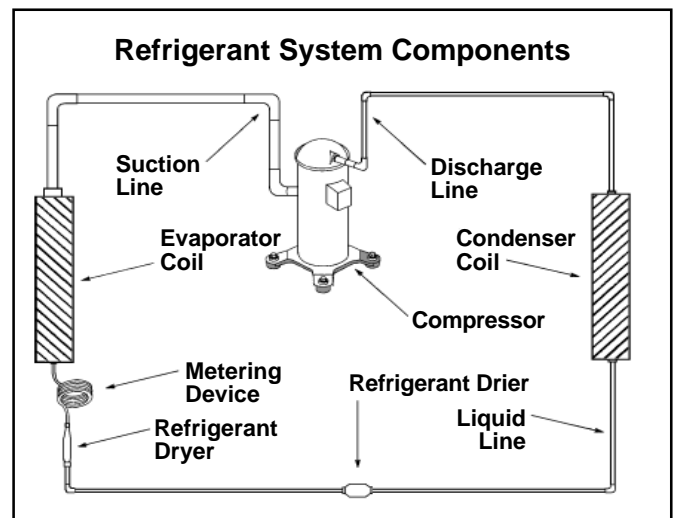

Sealed Refrigeration System Repairs

IMPORTANT

ANY SEALED SYSTEM REPAIRS TO COOL-ONLY MODELS REQUIRE THE INSTALLATION OF A LIQUID LINE DRIER. ALSO, ANY SEALED SYSTEM REPAIRS TO HEAT PUMP MODELS REQUIRE THE INSTALLATION OF A SUCTION LINE DRIER.

EQUIPMENT REQUIRED

1. Voltmeter
2. Ammeter
3. Ohmmeter
4. E.P.A. Approved Refrigerant Recovery System.
5. Vacuum Pump (capable of 200 microns or less vacuum.)
6. Acetylene Welder
7. Electronic Halogen Leak Detector (G.E. Type H-6 or equivalent.)
8. Accurate refrigerant charge measuring device such as:
 - a. Balance Scales - 1/2 oz. accuracy
 - b. Charging Board - 1/2 oz. accuracy
9. High Pressure Gauge - (0 - 400 lbs.)
10. Low Pressure Gauge - (30 - 150 lbs.)
11. Vacuum Gauge - (0 - 1000 microns)

EQUIPMENT MUST BE CAPABLE OF:

1. Recovery CFC's as low as 5%.
2. Evacuation from both the high side and low side of the system simultaneously.
3. Introducing refrigerant charge into high side of the system.
4. Accurately weighing the refrigerant charge actually introduced into the system.
5. Facilities for flowing nitrogen through refrigeration tubing during all brazing processes.

HERMETIC COMPONENT REPLACEMENT

The following procedure applies when replacing components in the sealed refrigeration circuit or repairing refrigerant leaks. (Compressor, condenser, evaporator, capillary tube, refrigerant leaks, etc.)

1. Recover the refrigerant from the system at the process tube located on the high side of the system by installing a line tap on the process tube. Apply gauge from process tube to EPA approved gauges from process tube to EPA approved recovery system. Recover CFC's in system to at least 5%.
2. Cut the process tube below pinch off on the suction side of the compressor.
3. Connect the line from the nitrogen tank to the suction process tube.
4. Drift dry nitrogen through the system and un-solder the more distant connection first. (Filter drier, high side process tube, etc.)
5. Replace inoperative component, and always install a new filter drier. Drift dry nitrogen through the system when making these connections.

HERMETIC COMPONENT REPLACEMENT cont'd

6. Pressurize system to 30 PSIG with proper refrigerant and boost refrigerant pressure to 150 PSIG with dry nitrogen.
 7. Leak test complete system with electric halogen leak detector, correcting any leaks found.
 8. Reduce the system to zero gauge pressure.
 9. Connect vacuum pump to high side and low side of system with deep vacuum hoses, or copper tubing. (Do not use regular hoses.)
 10. Evacuate system to maximum absolute holding pressure of 200 microns or less. NOTE: This process can be accelerated by use of heat lamps, or by breaking the vacuum with refrigerant or dry nitrogen at 5,000 microns. Pressure system to 5 PSIG and leave in system a minimum of 10 minutes. Release refrigerant, and proceed with evacuation of a pressure of 200 microns or less.
 11. Break vacuum by charging system from the high side with the correct amount of liquid refrigerant specified. This will prevent boiling the oil out of the crankcase, and damage to the compressor due to over heating.
- NOTE:** If the entire charge will not enter the high side, allow the remainder to enter the low side in small increments while operating the unit.
12. Restart unit several times after allowing pressures to stabilize. Pinch off process tubes, cut and solder the ends. Remove pinch off tool, and leak check the process tube ends.

SPECIAL PROCEDURE IN THE CASE OF COMPRESSOR MOTOR BURNOUT

1. Recover all refrigerant and oil from the system.
2. Remove compressor, capillary tube and filter drier from the system.
3. Flush evaporator condenser and all connecting tubing with dry nitrogen or equivalent, to remove all contamination from system. Inspect suction and discharge line for carbon deposits. Remove and clean if necessary.
4. Reassemble the system, including new drier strainer and capillary tube.
5. Proceed with processing as outlined under hermetic component replacement.

ROTARY COMPRESSOR SPECIAL TROUBLESHOOTING AND SERVICE

Basically, troubleshooting and servicing rotary compressors is the same as on the reciprocating compressor with only one main exception:

NEVER, under any circumstances, charge a rotary compressor through the LOW side. Doing so would cause permanent damage to the new compressor.

Refrigerant Charging

NOTE: BECAUSE THE RAC SYSTEM IS A SEALED SYSTEM, SERVICE PROCESS TUBES WILL HAVE TO BE INSTALLED. FIRST INSTALL A LINE TAP AND REMOVE REFRIGERANT FROM SYSTEM. MAKE NECESSARY SEALED SYSTEM REPAIRS AND VACUUM SYSTEM. CRIMP PROCESS TUBE LINE AND SOLDER END SHUT. DO NOT LEAVE A SERVICE VALVE IN THE SEALED SYSTEM.

Proper refrigerant charge is essential to proper unit operation. Operating a unit with an improper refrigerant charge will result in reduced performance (capacity) and/or efficiency. Accordingly, the use of proper charging methods during servicing will insure that the unit is functioning as designed and that its compressor will not be damaged.

Too much refrigerant (overcharge) in the system is just as bad (if not worse) than not enough refrigerant (undercharge). They both can be the source of certain compressor failures if they remain uncorrected for any period of time. Quite often, other problems (such as low air flow across evaporator, etc.) are misdiagnosed as refrigerant charge problems. The refrigerant circuit diagnosis chart will assist you in properly diagnosing these systems.

An overcharged unit will at times return liquid refrigerant (slugging) back to the suction side of the compressor eventually causing a mechanical failure within the compressor. This mechanical failure can manifest itself as valve failure, bearing failure, and/or other mechanical failure. The specific type of failure will be influenced by the amount of liquid being returned, and the length of time the slugging continues.

Not enough refrigerant (Undercharge) on the other hand, will cause the temperature of the suction gas to increase to the point where it does not provide sufficient cooling for the compressor motor. When this occurs, the motor winding temperature will increase causing the motor to overheat and possibly cycle open the compressor overload protector. Continued overheating of the motor windings and/or cycling of the overload will eventually lead to compressor motor or overload failure.

METHOD OF CHARGING

The acceptable method for charging the RAC system is the Weighed in Charge Method. The weighed in charge method is applicable to all units. It is the preferred method to use, as it is the most accurate.

The weighed in method should always be used whenever a charge is removed from a unit such as for a leak repair, compressor replacement, or when there is no refrigerant charge left in the unit. To charge by this method, requires the following steps:

1. Install a piercing valve to remove refrigerant from the sealed system. (Piercing valve must be removed from the system before recharging.)
2. Recover Refrigerant in accordance with EPA regulations.
3. Install a process tube to sealed system.
4. Make necessary repairs to system.
5. Evacuate system to 250 - 300 microns or less.
6. Weigh in refrigerant with the property quantity of R-22 refrigerant.
7. Start unit, and verify performance.
8. Crimp the process tube and solder the end shut.

NOTE: In order to access the sealed system it will be necessary to install Schrader type fittings to the process tubes on the discharge and suction of the compressor. Proper refrigerant recovery procedures need to be adhered to as outlined in EPA Regulations. THIS SHOULD ONLY BE ATTEMPTED BY QUALIFIED SERVICE PERSONNEL.

Refrigerant Charging

UNDERCHARGED REFRIGERANT SYSTEMS

An undercharged system will result in poor performance (low pressures, etc.) in both the heating and cooling cycle.

Whenever you service a unit with an undercharge of refrigerant, always suspect a leak. The leak must be repaired before charging the unit.

To check for an undercharged system, turn the unit on, allow the compressor to run long enough to establish working pressures in the system (15 to 20 minutes).

During the cooling cycle you can listen carefully at the exit of the metering device into the evaporator; an intermittent hissing and gurgling sound indicates a low refrigerant charge. Intermittent frosting and thawing of the evaporator is another indication of a

low charge, however, frosting and thawing can also be caused by insufficient air over the evaporator.

Checks for an undercharged system can be made at the compressor. If the compressor seems quieter than normal, it is an indication of a low refrigerant charge. A check of the amperage drawn by the compressor motor should show a lower reading. (Check the Unit Specification.) After the unit has run 10 to 15 minutes, check the gauge pressures.

Gauges connected to system with an undercharge will have low head pressures and substantially low suction pressures.

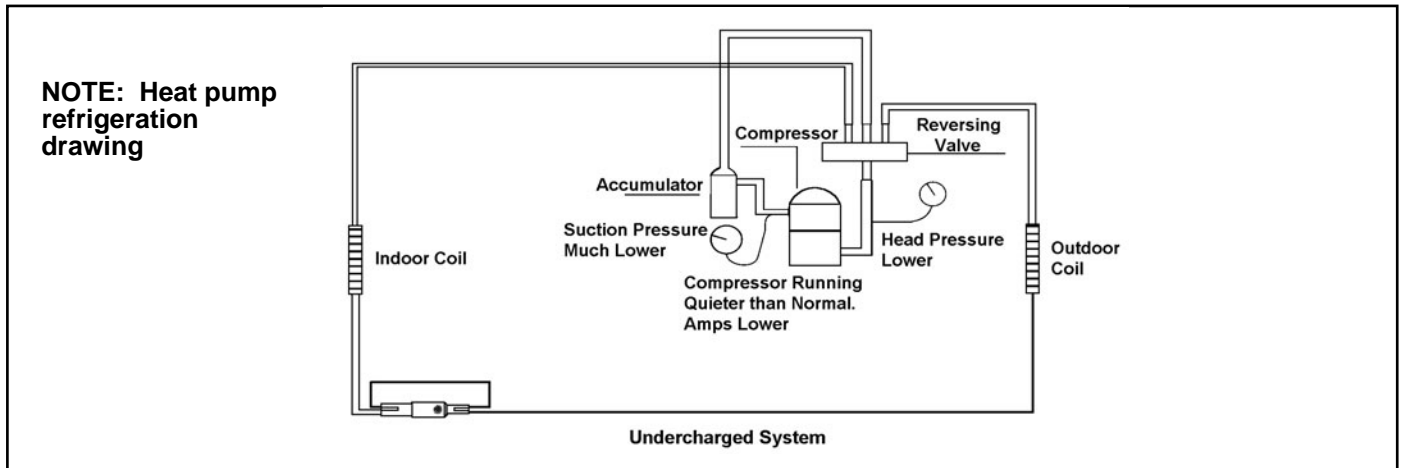

OVERCHARGED REFRIGERANT SYSTEMS

Compressor amps will be near normal or higher. Noncondensables can also cause these symptoms. To confirm, remove some of the charge, if conditions improve, system may be overcharged. If conditions don't improve, Noncondensables are indicated.

Whenever an overcharged system is indicated, always make sure that the problem is not caused by air flow problems. Improper air flow over the evaporator coil may indicate some of the same symptoms as an overcharged system.

An over charge can cause the compressor to fail, since it would be "slugged" with liquid refrigerant.

The charge for any system is critical. When the compressor is noisy, suspect an overcharge, when you are sure that the air quantity over the evaporator coil is correct. Icing of the evaporator will not be encountered because the refrigerant will boil later if at all. Gauges connected to system will usually have higher head pressure (depending upon amount of overcharge). Suction pressure should be slightly higher.

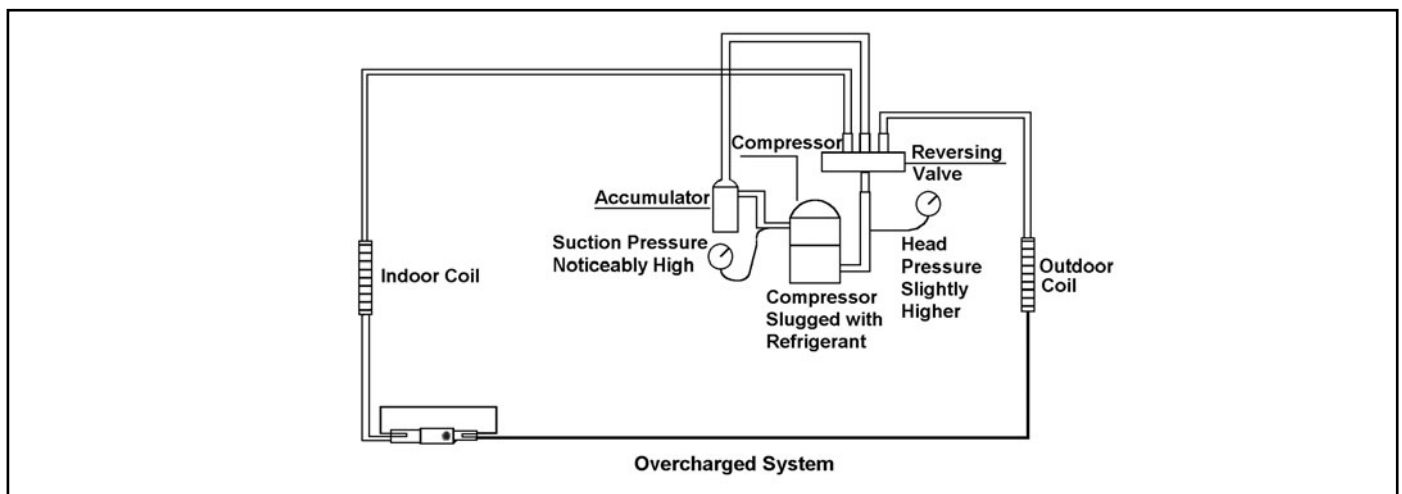

Refrigerant Charging

RESTRICTED REFRIGERANT SYSTEM

A quick check for either condition begins at the evaporator. With a partial restriction, there may be gurgling sounds at the metering device entrance to the evaporator. The evaporator in a partial restriction could be partially frosted or have an ice ball close to the entrance of the metering device. Frost may continue on the suction line back to the compressor.

Often a partial restriction of any type can be found by feel, as there is a temperature difference from one side of the restriction to the other.

With a complete restriction, there will be no sound at the metering device entrance. An amperage check of the compressor with a partial restriction may show normal current when compared to the unit specification. With a complete restriction the current drawn may be considerably less than normal, as the compressor is running in a deep vacuum (no load). Much of the area of the condenser will be relatively cool since most or all of the liquid refrigerant will be stored there.

The following conditions are based primarily on a system in the cooling mode.

Troubleshooting a restricted refrigerant system can be difficult. The following procedures are the more common problems and solutions to these problems. There are two types of refrigerant restrictions: Partial restrictions and complete restrictions.

- A partial restriction allows some of the refrigerant to circulate through the system.
- With a complete restriction there is no circulation of refrigerant in the system.
- Restricted refrigerant systems display the same symptoms as a "low-charge condition."
- When the unit is shut off, the gauges may equalize very slowly.
- Gauges connected to a completely restricted system will run in a deep vacuum. When the unit is shut off, the gauges will not equalize at all.

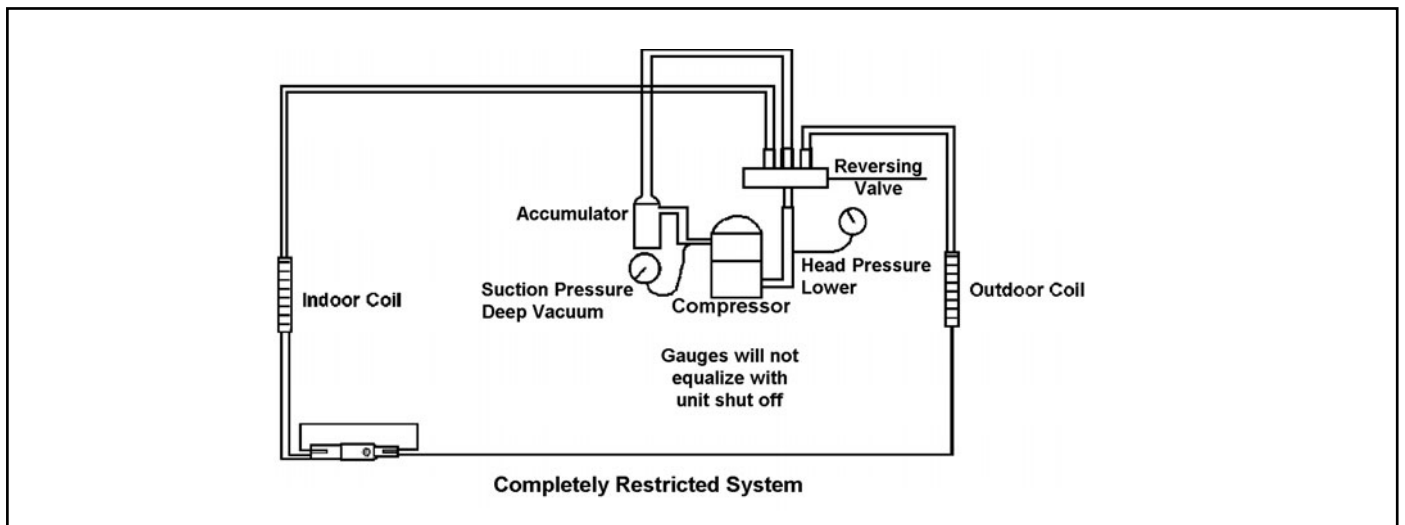
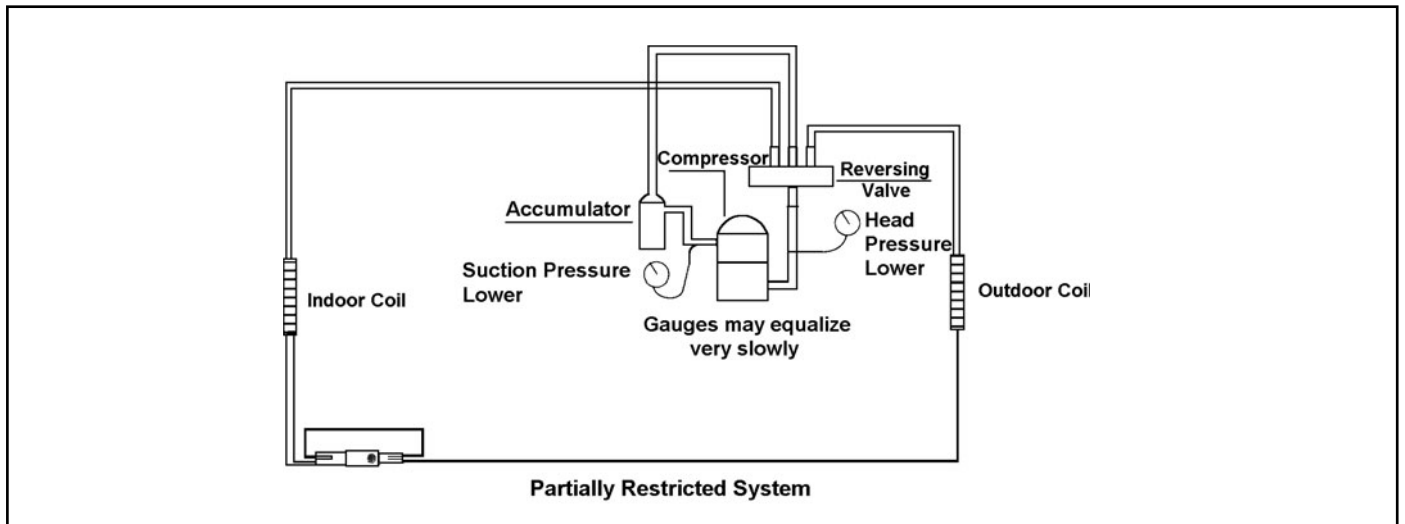

Cooling Only Room Air Conditioners: Troubleshooting Tips

Problem	Possible Cause	Action
Compressor does not run	Low voltage	Check voltage at compressor. 115V & 230V units will operate at 10% voltage variance
	T-stat not set cold enough or inoperative	Set t-stat to coldest position. Test t-stat & replace if inoperative
	Compressor hums but cuts off on B10 overload	Hard start compressor. Direct test compressor. If compressor starts, add starting components
	Open or shorted compressor windings	Check for continuity & resistance
	Open overload	Test overload protector & replace if inoperative
	Open capacitor	Test capacitor & replace if inoperative
	Inoperative system switch	Test for continuity in all positions. Replace if inoperative
	Broken, loose or incorrect wiring	Refer to appropriate wiring diagrams to check wiring

Problem	Possible Cause	Action
Fan motor does not run	Inoperative system switch	Test switch & replace if inoperative
	Broken, loose or incorrect wiring	Refer to applicable wiring diagram
	Open capacitor	Test capacitor & replace if inoperative
	Fan speed switch open	Test switch & replace if inoperative
	Inoperative fan motor	Test fan motor & replace if inoperative (be sure internal overload has had time to reset)

Problem	Possible Cause	Action
Does not cool or only cools slightly	Undersized unit	Refer to industry standard sizing chart
	T-stat open or inoperative	Set to coldest position. Test t-stat & replace if necessary
	Dirty filter	Clean as recommended in Owner's Manual
	Dirty or restricted condenser or evaporator coil	Use pressure wash or biodegradable cleaning agent to clean
	Poor air circulation	Adjust discharge louvers. Use high fan speed
	Fresh air or exhaust air door open on applicable models	Close doors. Instruct customer on use of this feature
	Low capacity - undercharge	Check for leak & make repair
	Compressor not pumping properly	Check amperage draw against nameplate. If not conclusive, make pressure test

Cooling Only Room Air Conditioners: Troubleshooting Tips

Problem	Possible Cause	Action
Unit does not run	Fuse blown or circuit tripped	Replace fuse, reset breaker. If repeats, check fuse or breaker size. Check for shorts in unit wiring & components
	Power cord not plugged in	Plug it in
	System switch in "OFF" position	Set switch correctly
	Inoperative system switch	Test for continuity in each switch position
	Loose or disconnected wiring at switch or other components	Check wiring & connections. Reconnect per wiring diagram

Problem	Possible Cause	Action
Evaporator coil freezes up	Dirty filter	Clean as recommended in Owner's Manual
	Restricted airflow	Check for dirty or obstructed coil. Use pressure wash or biodegradable cleaning agent to clean
	Inoperative t-stat	Test for shorted t-stat or stuck contacts
	Short of refrigerant	De-ice coil & check for leak
	Inoperative fan motor	Test fan motor & replace if inoperative
	Partially restricted capillary tube	De-ice coil. Check temp. differential (delta T) across coil. Touch test coil return bends for same temp. Test for low running current

Problem	Possible Cause	Action
Compressor runs continually & does not cycle off	Excessive heat load	Unit undersized. Test cooling performance & replace with larger unit if needed
	Restriction in line	Check for partially iced coil & check temperature split across coil
	Refrigerant leak	Check for oil at silver soldered connections. Check for partially iced coil. Check split across coil. Check for low running amperage
	T-stat contacts stuck	Check operation of t-stat. Replace if contacts remain closed.
	T-stat incorrectly wired	Refer to appropriate wiring diagram

Problem	Possible Cause	Action
T-stat does not turn unit off	T-stat contacts stuck	Disconnect power to unit. Remove cover of t-stat & check if contacts are stuck. If so, replace t-stat
	T-stat set at coldest point	Turn to higher temp. setting to see if unit cycles off
	Incorrect wiring	Refer to appropriate wiring diagrams
	Unit undersized for area to be cooled	Refer to industry standard sizing chart

Cooling Only Room Air Conditioners: Troubleshooting Tips

Problem	Possible Cause	Action
Compressor runs for short periods only. Cycles on overload	Overload inoperative. Opens too soon	Check operation of unit. Replace overload if system operation is satisfactory
	Compressor restarted before system pressures equalized	Allow a minimum of 2 minutes to allow pressures to equalize before attempting to restart. Instruct customer of waiting period
	Low or fluctuating voltage	Check voltage with unit operating. Check for other appliances on circuit. Air conditioner should be in separate circuit for proper voltage & fused separately
	Incorrect wiring	Refer to appropriate wiring diagram
	Shorted or incorrect capacitor	Check by substituting a known good capacitor of correct rating
	Restricted or low air flow through condenser coil	Check for proper fan speed or blocked condenser
	Compressor running abnormally hot	Check for kinked discharge line or restricted condenser. Check amperage

Problem	Possible Cause	Action
T-stat does not turn unit on	Loss of charge in t-stat bulb	Place jumper across t-stat terminals to check if unit operates. If unit operates, replace t-stat.
	Loose or broken parts in t-stat	Check as above
	Incorrect wiring	Refer to appropriate wiring diagram

Problem	Possible Cause	Action
Noisy operation	Poorly installed	Refer to Installation Manual for proper installation
	Fan blade striking chassis	Reposition - adjust motor mount
	Compressor vibrating	Check that compressor grommets have not deteriorated. Check that compressor mounting parts are not missing
	Improperly mounted or loose cabinet parts	Check assembly & parts for looseness, rubbing & rattling

Problem	Possible Cause	Action
Water leaks into the room	Evaporator drain pan overflowing	Clean obstructed drain trough
	Condensation forming on base pan	Evaporator drain pan broken or cracked. Reseal or replace
	Poor installation resulting in rain entering the room	Check installation instructions. Reseal as required
	Condensation on discharge grille louvers	Clean the dirty evaporator coil. Use pressure wash or biodegradable cleaning agent to clean
	Chassis gasket not installed	Install gasket, per Installation manual
	Downward slope of unit is too steep	Refer to installation manual for proper installation

Cooling Only Room Air Conditioners: Troubleshooting Tips

Problem	Possible Cause	Action
Water "spitting" into room	Sublimation: When unconditioned saturated, outside air mixes with conditioned air, condensation forms on the cooler surfaces	Ensure that foam gaskets are installed in between window panes & in between the unit & the sleeve. Also, ensure that fresh air/exhaust vents (on applicable models) are in the closed position & are in tact
	Downward pitch of installation is too steep	Follow installation instructions to ensure that downward pitch of installed unit is no less than 1/4" & no more than 3/8"
	Restricted coil or dirty filter	Clean & advise customer of periodic cleaning & maintenance needs of entire unit

Problem	Possible Cause	Action
Excessive moisture	Insufficient air circulation thru area to be air conditioned	Adjust louvers for best possible air circulation
	Oversized unit	Operate in "MoneySaver" position
	Inadequate vapor barrier in building structure, particularly floors	Advise customer

Problem	Possible Cause	Action
T-stat short cycles	T-stat differential too narrow	Replace t-stat
	Plenum gasket not sealing, allowing discharge air to short cycle t-stat	Check gasket. Reposition or replace as needed
	Restricted coil or dirty filter	Clean & advise customer of periodic cleaning & maintenance needs of entire unit

Problem	Possible Cause	Action
Prolonged off cycles (automatic operation)	Anticipator (resistor) wire disconnected at t-stat or system switch	Refer to appropriate wiring diagram
	Anticipator (resistor) shorted or open	Disconnect plus from outlet. Remove resistor from bracket. Insert plug & depress "COOL" & "FAN AUTOMATIC" buttons. Place t-stat to warmest setting. Feel resistor for temperature. If no heat, replace resistor
	Partial loss of charge in t-stat bulb causing a wide differential	Replace t-stat

Problem	Possible Cause	Action
Outside water leaks	Evaporator drain pan cracked or obstructed	Repair, clean or replace as required
	Water in compressor area	Detach shroud from pan & coil. Clean & remove old sealer. Reseal, reinstall & check
	Obstructed condenser coil	Use pressure wash or biodegradable cleaning agent to clean
	Fan blade/slinger ring improperly positioned	Adjust fan blade to 1/2" of condenser coil

Heat / Cool Room Air Conditioners: Troubleshooting Tips

Problem	Possible Cause	Action
Room temperature uneven (Heating cycle)	Heat anticipator (resistor) shorted (on applicable models)	Disconnect power to unit. Remove resistor from t-stat bulb block. Plus in unit & allow to operate. Feel resistor for heat. If not heat, replace resistor
	Wide differential - partial loss of t-stat bulb charge	Replace t-stat & check
	Incorrect wiring	Refer to appropriate wiring diagram. Resistor is energized during "ON" cycle of compressor or fan.

Problem	Possible Cause	Action
Unit will not defrost	Incorrect wiring	Refer to appropriate wiring diagram
	Defrost control timer motor not advancing (applicable models)	Check for voltage at "TM" & "TM1" on timer. If no voltage, replace control
	Defrost control out of calibration (applicable models)	If outside coil temperature is 25F or below, & preselected time limit has elapsed, replace defrost control
	Defrost control contacts stuck	If contacts remain closed between terminals "2" & "3" of the defrost control after preselected time interval has passed, replace control
	Defrost control bulb removed from or not making good coil contact	Reinstall & be assured that good bulb to coil contact is made

Problem	Possible Cause	Action
Does not heat adequately	Exhaust or fresh air door open	Check if operating properly. Instruct customer on proper use of control
	Dirty filter	Clean as recommended in Owner's Manual
	Unit undersized	Check heat rise across coil. If unit operates efficiently, check if insulation can be added to attic or walls. If insulation is adequate, recommend additional unit or larger one
	Outdoor t-stat open (applicable models)	T-stat should close at 38°F. Check continuity of control. If temperature is below 38°F, replace control
	Heater hi-limit control cycling on & off	Check for adequate fan air across heater. Check control for open at 160°F & close at 150°F
	Shorted supplementary heater	Ohmmeter check, approx. 32-35 ohms
	Incorrect wiring	Check applicable wiring diagram

Heat / Cool Room Air Conditioners: Troubleshooting Tips

Problem	Possible Cause	Action
Unit cools when heat is called for	Incorrect wiring	Refer to applicable wiring diagram
	Defective solenoid coil	Check for continuity of coil
	Reversing valve fails to shift	Block condenser coil & switch unit to cooling. Allow pressure to build up in system, then switch to heating. If valve fails to shift, replace valve.
	Inoperative system switch	Check for continuity of system switch

Problem	Possible Cause	Action
Cooling adequate, but heating insufficient	Heating capillary tube partially restricted	Check for partially starved outer coil. Replace heating capillary tube
	Check valve leaking internally	Switch unit several times from heating to cooling. Check temperature rise across coil. Refer to specification sheet for correct temperature rise
	Reversing valve failing to shift completely; bypassing hot gas	De-energize solenoid coil, raise head pressure, energize solenoid to break loose. If valve fails to make complete shift, replace valve.

Components

Model CP14N10

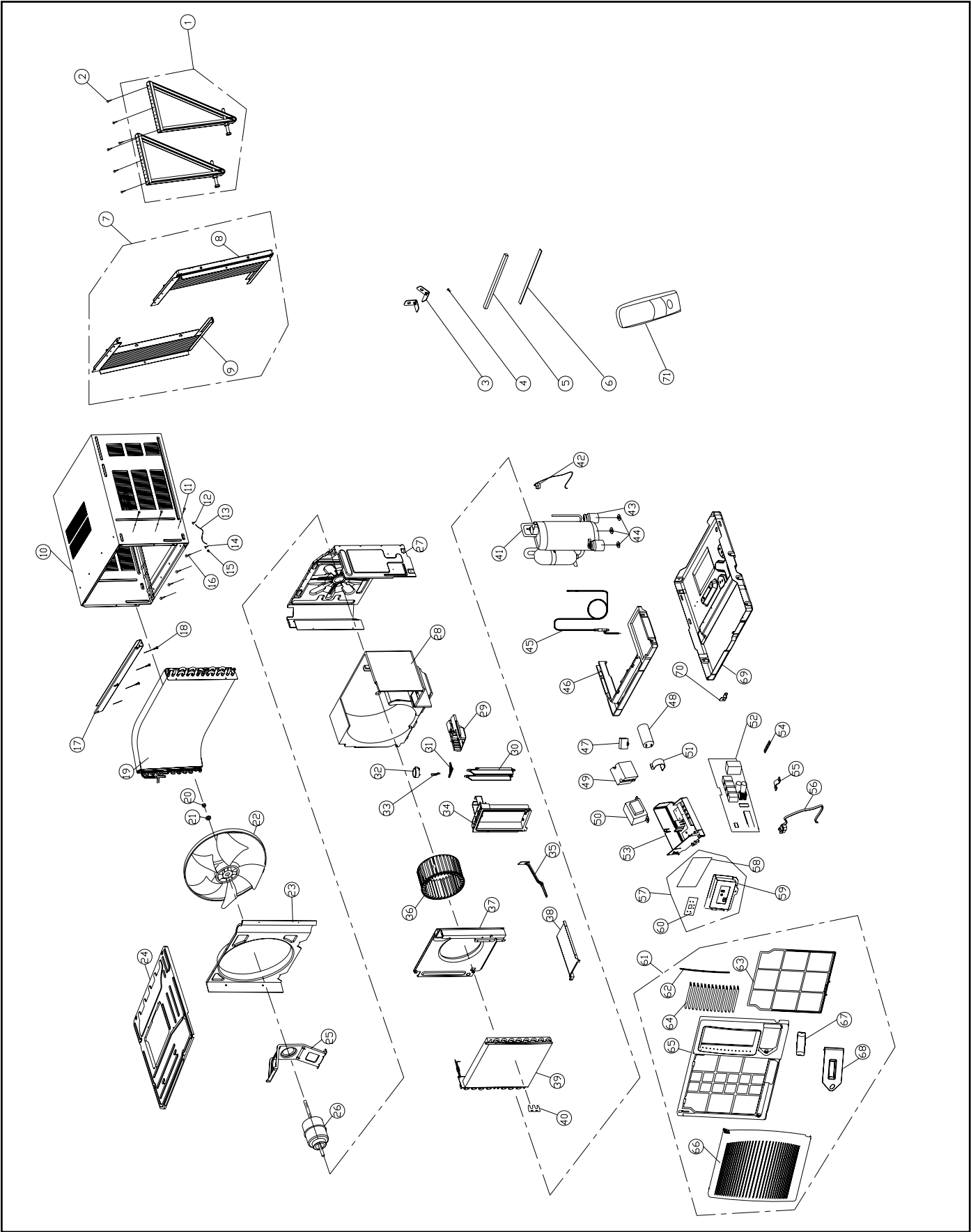

Model CP14N10

No	Description	Qty	Friedrich Part#	Code
1	Supporter Assy	1	67700200	
2	Screw ST4.2X13	7	67700154	
3	Window locking bracket	2	67700113	
4	Screw 4X20	6	67700151	
5	Seal strip 1	1	67700128	
6	Seal strip 2	1	67700129	
7	Curtain Assembly Left and Right	1	67700201	
8	Right Curtain	1	67700202	
9	Left Curtain	1	67700203	
10	Cabinet Assy	1	67700204	
11	Screw ST4.2X6.5	6	67700155	
12	Screw M4X8	1	67700149	
13	Connect cord	1	67700170	
14	Screw M4X5	1	67700205	
15	Washer 4	1	67700158	
16	Screw ST4.2X22	4	67700153	
17	Top Rail Assy	1	67700206	
18	Screw ST4X10	4	67700152	
19	Condenser Assy	1	67700207	
20	Nut with Washer M10	1	67700157	
21	Washer 10	1	67700159	
22	Fan Blade	1	67700117	
23	Shroud, Fan Blade	1	67700208	
24	Top Cover	1	67700110	
25	Motor Support	1	67700112	
26	Motor CJ100U	1	67700209	
27	Innerwall	1	67700109	
28	Shroud	1	67700127	
29	Air Outlet Foam	1	67700130	
30	Swing Louver	2	67700210	
31	Swing Linkage	2	67700124	
32	Motor, Swing Louver	1	67700211	
33	Inflectional Axis	1	67700121	
34	Swing Support	1	67700125	
35	Fresh Air Door	1	67700212	
36	Blower Wheel	1	67700116	

Model CP14N10

No	Description	Qty	Friedrich Part#	Code
37	Clapboard of Snail Shell	1	67700108	
38	Base Plate of Air Flue	1	67700106	
39	Evaporator Assy	1	67700103	
40	Sensor Holder	1	67700213	
41	Compressor 44B124HXCEF	1	67700214	
42	Overload Protector	1	67700215	
43	Compressor Gasket	3	67700216	
44	Nut with washer M8	3	67700156	
45	Capillary Assy	1	67700217	
46	Water Tray	1	67700131	
47	Capacitor 15uF/300VAC	1	67700218	
48	Capacitor 50uF/450V	1	67700219	
49	Relay 841-S-1A-D 110/120V	1	67700220	
50	Transformer 41X26.5C	1	67700221	
51	Capacitor clamp	1	67700114	
52	Main PCB M2A91J	1	67700222	
53	Electric box	1	67700136	
54	Isolation Washer D	1	67700223	
55	Wire Clamp	1	67700160	
56	Power cord	1	67700224	
57	Receiver Cover	1	67700225	
58	Membrane	1	67700226	
59	Control Panel Cover A	1	67700227	
60	Display Board 2A91J	1	67700228	
61	Front Panel Assy	1	67700229	
62	Guide Louver Linkage	1	67700230	
63	Filter	1	67700231	
64	Guide Louver	14	67700232	
65	Front Case	1	67700233	
66	Front Panel	1	67700234	
67	AS Window	1	67700235	
68	Remote Cover	1	67700236	
69	Chassis	1	67700237	
70	Chassis Fixer	1	67700105	
71	Remote Control	1	67700171	

Models CP18C30 & CP18N30

No	Description	Qty	Friedrich Part#	Code
1	Supporter Assy	1	67700132	
2	Self-threading Screw ST4.2x22	7	67700154	
3	Window Locking Bracket	2	67700113	
4	Screw 4X20	6	67700151	
5	Seal Strip 1	1	67700128	
6	Seal Strip 2	1	67700129	
7	Curtain Assemby Left and Right	1	67700166	
8	Right Curtain	1	67700168	
9	Left Curtain	1	67700167	
10	Cabinet Assy	1	67700111	
11	Self-threading Screw ST4.2X6.5	6	67700155	
12	Screw Assay M4x8	1	67700149	
13	Connect Cord	1	67700170	
14	Screw M4X6	1	67700150	
15	Washer 4	1	67700158	
16	Self-threading Screw ST4.2x22	6	67700153	
17	Top Rail	1	67700134	
18	Self-threading Screw with Gasket ST4X10	4	67700152	
19	Condenser Assy	1	67700104	
20	Nut with Washer M10	1	67700157	
21	Washer 6	1	67700159	
22	Fan Blade	1	67700117	
23	Shroud, Fan Blade	1	67700107	
24	Upper Clapboard	1	67700110	
25	Motor Support	1	67700112	
26	Motor CJ100B	1	67700164	
27	Innerwall	1	67700109	
28	Blower Front	1	67700127	
29	Air Outlet Foam 1	1	67700130	
30	Swing Louver	2	67700120	
31	Lever of Vertical Guider	2	67700124	
32	Swing Motor SM020B	1	67700133	
33	Inflectional Axis	1	67700121	
34	Cross Beam	1	67700125	
35	Fresh Air Door	1	67700123	

Models CP18C30 & CP18N30

No	Description	Qty	Friedrich Part#	Code
36	Blower Wheel	1	67700116	
37	Front Clapboard of Snail Shell	1	67700108	
38	Base Plate of Air Flue	1	67700106	
39	Evaporator Assy	1	67700103	
40	Insert Block	2	67700141	
41	Compressor 2K25S236AHF	1	67700101	
42	Overload Protector	1	67700102	
43	Compressor Gasket AD7070815	3	67700161	
44	Nut with Washer M8	3	67700156	
45	Capillary Assay	1	67700115	
46	Water Tray	1	67700131	
47	Capacitor 7uF/450V	1	67700145	
48	Capacitor CBB65 40uF/450V(TUV)	1	67700144	
49	Relay 841-S-1A-D 200V/240V TUV	1	67700147	
50	Power Transformer 41X26.5F	1	67700146	
51	Capacitor Clamp	1	67700114	
52	Electric box	1	67700136	
53	Main PCB J25713J	1	67700142	
54	Fixed Clamp	1	67700160	
55	Power cord	1	67700169	
56	Display Board J25713J	1	67700143	
57	Receiver Cover	1	67700138	
58	Control Panel Cover	1	67700137	
59	Touch Pad Plate	1	67700148	
60	Front Panel Assy	1	67700165	
61	Guide louver linkage	1	67700122	
62	Filter	1	67700163	
63	Horizontal air guider1	8	67700118	
64	Horizontal air guider2	1	67700119	
65	Up Filter Guide	1	67700140	
66	Down Filter Guide	1	67700139	
67	Panel	1	67700135	
68	Basepan	1	67700126	
69	Chassis Fixer	1	67700105	
70	Drain Plug	1	67700162	
71	Remote Control	1	67700171	

Components

Model CP24N30

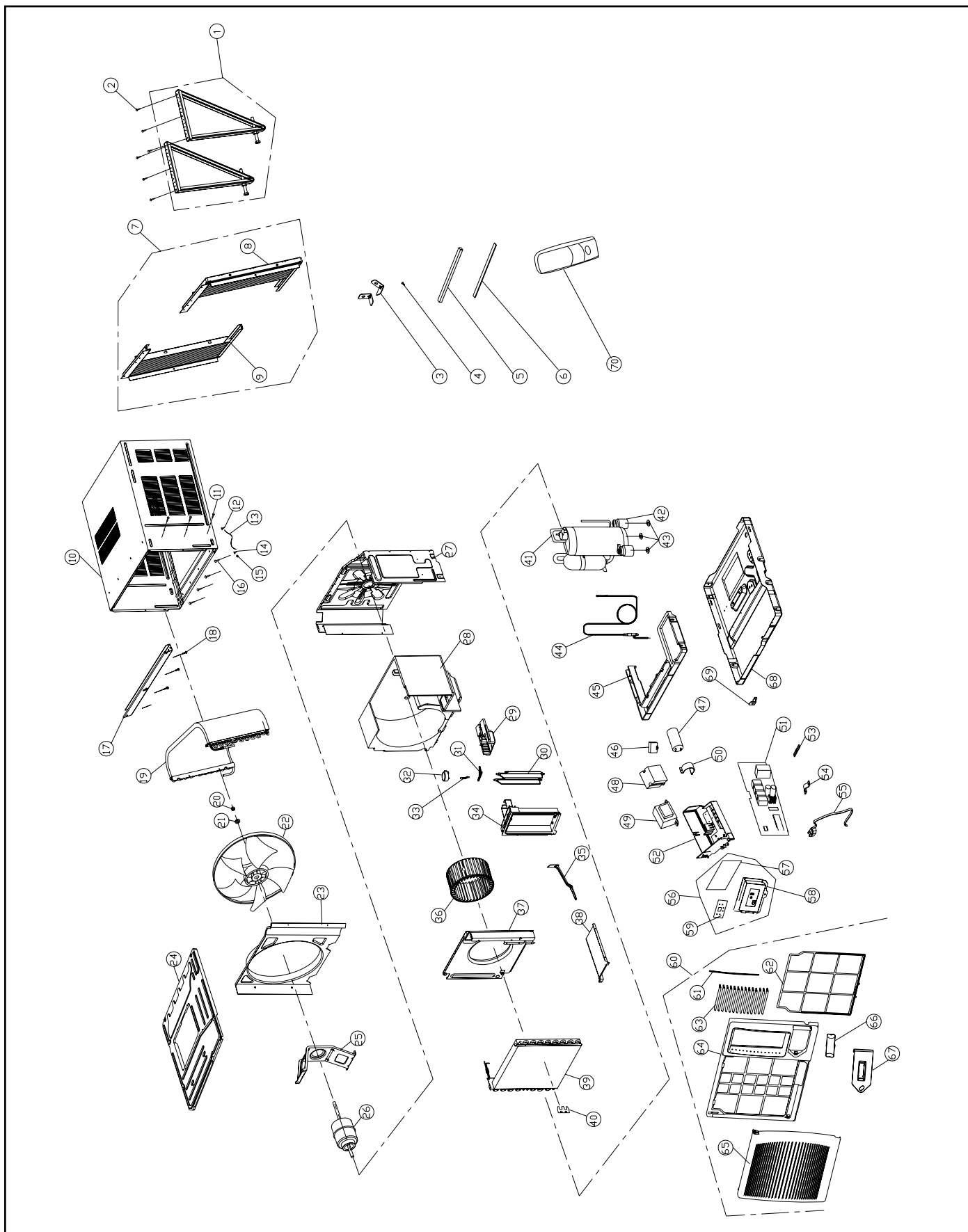

Model CP24N30

No	Description	Qty	Friedrich Part#	Code
1	Supporter Assy	1	67700200	
2	Screw ST4.2X13	7	67700154	
3	Window locking bracket	2	67700113	
4	Screw 4X20	6	67700151	
5	Seal strip 1	1	67700128	
6	Seal strip 2	1	67700129	
7	LT & RT Curtain Assembly	1	67700201	
8	Right Curtain	1	67700202	
9	Left Curtain	1	67700203	
10	Cabinet Assy	1	67700238	
11	Screw ST4.2X6.5	6	67700155	
12	Screw M4X8	1	67700149	
13	Connect cord	1	67700170	
14	Screw M4X5	1	67700205	
15	Washer 4	1	67700158	
16	Screw ST4.2X22	4	67700153	
17	Top Rail Assy	1	67700206	
18	Screw ST4X10	4	67700152	
19	Condenser Assy	1	67700239	
20	Nut with Washer M10	1	67700157	
21	Washer 10	1	67700159	
22	Fan Blade	1	67700117	
23	Shroud, Fan Blade	1	67700208	
24	Top Cover	1	67700240	
25	Motor Support	1	67700112	
26	Motor CJ100U	1	67700241	
27	Innerwall	1	67700109	
28	Shroud	1	67700242	
29	Air Outlet Foam	1	67700130	
30	Swing Louver	2	67700210	
31	Swing Linkage	2	67700124	
32	Motor, Swing Louver	1	67700133	
33	Inflectional Axis	1	67700121	
34	Swing Support	1	67700125	
35	Fresh Air Door	1	67700212	
36	Blower Wheel	1	67700243	
37	Blower Front	1	67700108	

Model CP24N30

No	Description	Qty	Friedrich Part#	Code
38	Base Plate of Air Flue	1	67700106	
39	Evaporator Assy	1	67700103	
40	Sensor Holder	1	67700213	
41	Compressor 44B124HXCEF	1	67700244	
42	Overload Protector	1	67700215	
43	Compressor Gasket	3	67700216	
44	Nut with washer M8	3	67700156	
45	Capillary Assy	1	67700245	
46	Water Tray	1	67700131	
47	Capacitor 15uF/300VAC	1	67700145	
48	Capacitor 50uF/450V	1	67700246	
49	Relay 841-S-1A-D 110/120V	1	67700147	
50	Transformer 41X26.5C	1	67700247	
51	Capacitor clamp	1	67700114	
52	Main PCB M2A91J	1	67700248	
53	Electric box	1	67700136	
54	Isolation Washer D	1	67700223	
55	Wire Clamp	1	67700160	
56	Power cord	1	67700249	
57	Receiver Cover	1	67700225	
58	Touch Pad Plate	1	67700226	
59	Control Panel Cover A	1	67700227	
60	Display Board 2A91J	1	67700228	
61	Front Panel Assy	1	67700229	
62	Guide Louver Linkage	1	67700230	
63	Filter	1	67700231	
64	Guide Louver	14	67700232	
65	Front Case	1	67700233	
66	Front Panel	1	67700234	
67	AS Window	1	67700235	
68	Remote Cover	1	67700236	
69	Basepan	1	67700250	
70	Chassis Fixer	1	67700105	
71	Remote Control	1	67700171	



Friedrich Air Conditioning Company

P.O. Box 1540
San Antonio, TX 78295
210.357.4400
www.friedrich.com

ROOM AIR CONDITIONERS LIMITED WARRANTY

FIRST YEAR

ANY PART: If any part supplied by FRIEDRICH fails because of a defect in workmanship or material within twelve months from date of original purchase, FRIEDRICH will repair the product at no charge, provided room air conditioner is reasonably accessible for service. Any additional labor cost for removing inaccessible units and/or charges for mileage related to travel by a Service Agency that exceeds 25 miles one way will be the responsibility of the owner. This remedy is expressly agreed to be the exclusive remedy within twelve months from the date of the original purchase.

SECOND THROUGH FIFTH YEAR

SEALED REFRIGERANT SYSTEM: If the Sealed Refrigeration System (defined for this purpose as the compressor, condenser coil, evaporator coil, reversing valve, check valve, capillary, filter drier, and all interconnecting tubing) supplied by FRIEDRICH in your Room Air Conditioner fails because of a defect in workmanship or material within sixty months from date of purchase, FRIEDRICH will pay a labor allowance and parts necessary to repair the Sealed Refrigeration System; **PROVIDED** FRIEDRICH will not pay the cost of diagnosis of the problem, removal, freight charges, and transportation of the air conditioner to and from the Service Agency, and the reinstallation charges associated with repair of the Sealed Refrigeration System. All such cost will be the sole responsibility of the owner. This remedy is expressly agreed to be the exclusive remedy within sixty months from the date of the original purchase.

APPLICABILITY AND LIMITATIONS: This warranty is applicable only to units retained within the Fifty States of the U.S.A., District of Columbia, and Canada. This warranty is not applicable to:

1. Air filters or fuses.
2. Products on which the model and serial numbers have been removed.
3. Products which have defects or damage which results from improper installation, wiring, electrical current characteristics, or maintenance; or caused by accident, misuse or abuse, fire, flood, alterations and/or misapplication of the product and/or units installed in a corrosive atmosphere, default or delay in performance caused by war, government restrictions or restraints, strikes, material shortages beyond the control of FRIEDRICH, or acts of God.

OBTAINING WARRANTY PERFORMANCE: Service will be provided by the **FRIEDRICH Authorized Dealer or Service Organization** in your area. They are listed in the Yellow Pages. If assistance is required in obtaining warranty performance, write to: Room Air Conditioner Service Manager, Friedrich Air Conditioning Co., P.O. Box 1540, San Antonio, TX 78295-1540.

LIMITATIONS: THIS WARRANTY IS GIVEN IN LIEU OF ALL OTHER WARRANTIES. Anything in the warranty notwithstanding, ANY IMPLIED WARRANTIES OF FITNESS FOR PARTICULAR PURPOSE AND/OR MERCHANTABILITY SHALL BE LIMITED TO THE DURATION OF THIS EXPRESS WARRANTY. MANUFACTURER EXPRESSLY DISCLAIMS AND EXCLUDES ANY LIABILITY FOR CONSEQUENTIAL OR INCIDENTAL DAMAGE FOR BREACH OF ANY EXPRESSED OR IMPLIED WARRANTY.

NOTE: Some states do not allow limitations on how long an implied warranty lasts, or do not allow the limitation or exclusion of consequential or incidental damages, so the foregoing exclusions and limitations may not apply to you.

OTHER: This warranty gives you specific legal rights, and you may also have other rights which vary from state to state.

PROOF OF PURCHASE: Owner must provide proof of purchase in order to receive any warranty related services.

All service calls for explaining the operation of this product will be the sole responsibility of the consumer.

All warranty service must be provided by an **Authorized FRIEDRICH Service Agency**, unless authorized by FRIEDRICH prior to repairs being made.

(10-04)



Friedrich Air Conditioning Co.

Post Office Box 1540 • San Antonio, Texas 78295-1540

4200 N. Pan Am Expressway • San Antonio, Texas 78218-5212

(210) 357-4400 • FAX (210) 357-4480

www.friedrich.com

Printed in the U.S.A.

CP-14-18-24-Svc-Prts-07 (3-07)