

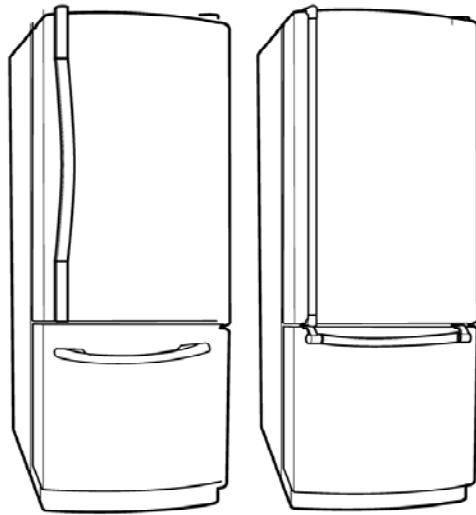

REFRIGERATOR

SERVICE MANUAL

CAUTION
BEFORE SERVICING THE UNIT,
READ THE SAFETY PRECAUTIONS IN THIS MANUAL.



Models :

LRDN22720BQ
LRDN22720WW
LRDN22720BK
LRDN22725ST
LRDN22711TT
LRDN22725TT
LRDN22711SW
LRDN22725SW
LRDC22743SW
LRDC22743ST
LRDC22743TT
LRDC22731WW
LRDC20731ST
LRDC20731TT
LRDC20731SW

CONTENTS

Safety Precautions	2
1. Specifications	3
2. Parts Identification	4
3. Disassembly	5
Door.....	5
Door Switch.....	5
Fan & Fan Motor.....	6
Defrost Control Assembly.....	6
Lamp.....	6
Control Box-Refrigerator.....	6
Multi Duct.....	6
4. Adjustment	7
Compressor.....	7
PTC-Starter.....	7
OLP (Overload Protector).....	8
To Remove The Cover PTC.....	8
5. Circuit Diagram	9
6. Troubleshooting	10
Compressor & Electric Components.....	10
PTC & OLP.....	11
Other Electrical Components.....	12
Service Diagnosis Chart.....	13
Refrigeration Cycle.....	14
7. Operation Principle & Repair Method Of Ice Maker	16
8. Water Filter	20
Water Filter Cartridge Replacement.....	20
Water Dispenser.....	21
9. Description Of Function & Circuit Of MICOM	22
10.Refrigerator Exploded View & Service Parts List	43

SAFETY PRECAUTIONS

Please read the following instructions before servicing your refrigerator:

1. Check the refrigerator for current leakage.
2. To prevent electric shock, unplug before servicing.
3. Always check line voltage and amperage.
4. Use standard electrical components.
5. Don't touch metal products in the freezer with wet hands. This may cause frostbite.
6. Prevent water from spilling onto electric elements or the machine parts.
7. Before tilting the refrigerator, remove all materials from on or in the refrigerator.
8. When servicing the evaporator, wear gloves to prevent injuries from the sharp evaporator fins.
9. Service on the refrigerator should be performed by a qualified technician. Sealed system repair must be performed by a CFC certified technician.

1. SPECIFICATIONS

20 cu. ft. / 22 cu. ft.

ITEMS	SPECIFICATIONS	ITEMS	SPECIFICATIONS	
DOOR DESIGN	Side Rounded	VEGETABLE TRAY	Opaque Drawer Type	
DIMENSIONS (inches)	29 7/8 x 31 3/4 x 67 7/8 (WxDxH) 20cu.ft	COMPRESSOR	PTC Starting Type	
	32 7/8 x 31 3/4 x 69 1/2 (WxDxH) 22cu.ft Dispenser	EVAPORATOR	Fin Tube Type	
	32 7/8 x 31 3/4 x 68 1/2 (WxDxH) 22cu.ft	CONDENSER	Wire Condenser	
NET WEIGHT (pounds)	238.4 (20cu.ft)	REFRIGERANT	R-134a (115 g)	
	246.9 (22cu.ft)	LUBRICATING OIL	Freol @ 10G (310 cc)	
COOLING SYSTEM	Fan Cooling	DEFROSTING DEVICE	SHEATH HEATER	
TEMPERATURE CONTROL	Micom Control	LAMP	REFRIGERATOR	60 W (2EA)
DEFROSTING SYSTEM	Full Automatic Heater Defrost		FREEZER	40 W (1EA)
DOOR FINISH	Embossed Metal, VCM, Stainless			
HANDLE TYPE	Bar			
INNER CASE	ABS Resin			
INSULATION	Polyurethane Foam			

2. PARTS IDENTIFICATION

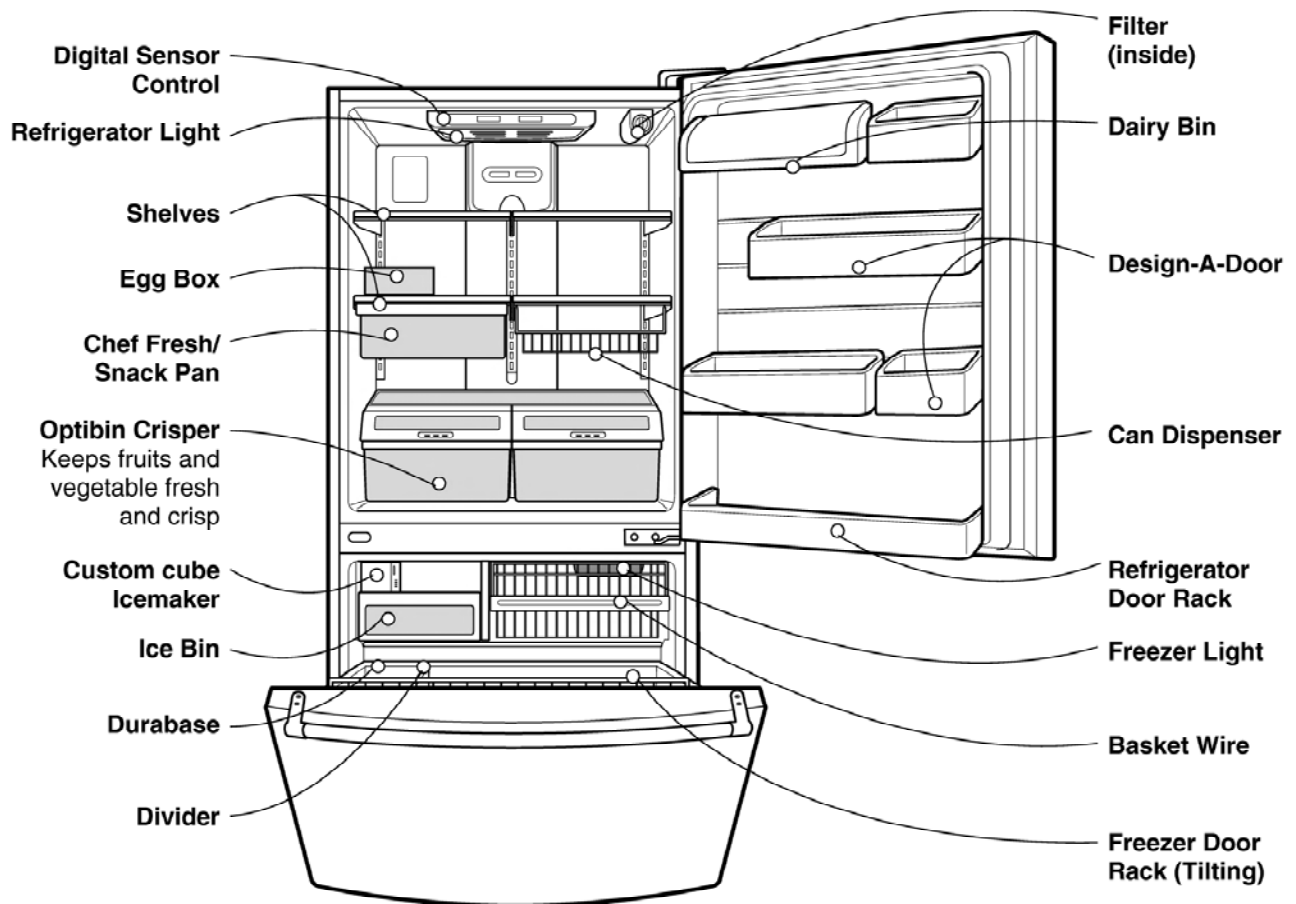

3. DISASSEMBLY

3-1 DOOR

● Refrigerator Door

1. Remove the hinge cover by pulling it upwards.
2. Loosen the hexagonal bolts attaching the upper hinge to the body and lift the freezer door.

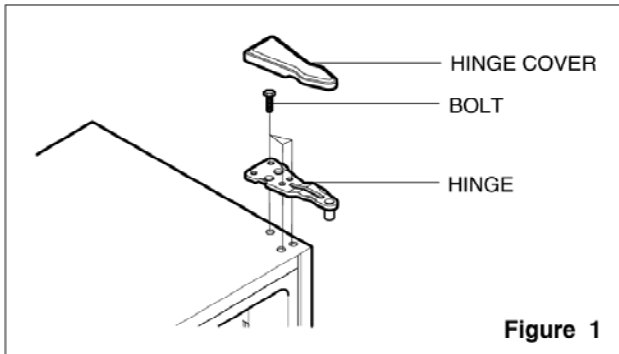

3. Pull out the door gasket to remove from the door foam assembly.

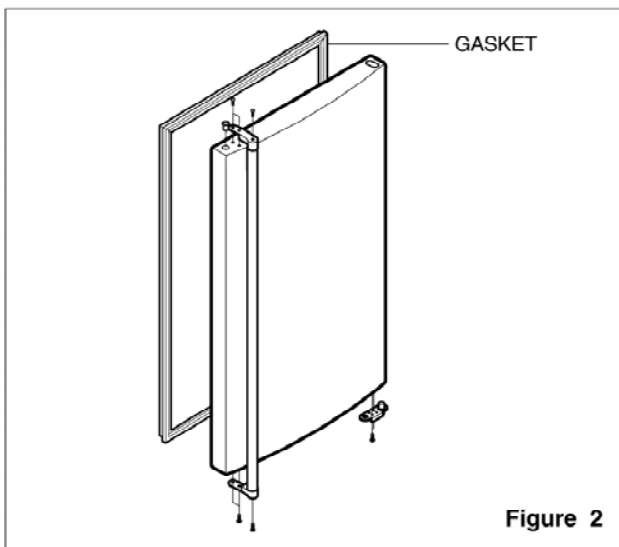

● Freezer Door

1. Loosen the hexagonal bolts attaching the lower hinge to the body to remove the refrigerator door only.

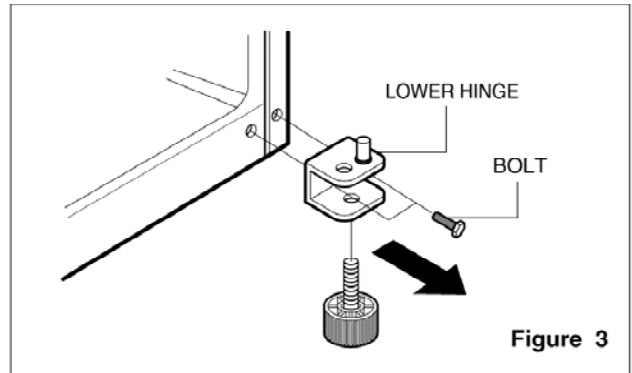

2. Pull out the door gasket to remove from the door foam assembly.

3-2 DOOR SWITCH

1. To remove the door switch, pry it out with a slotted-type driver, as shown in (Figure 4).
2. Disconnect the lead wire from the switch.

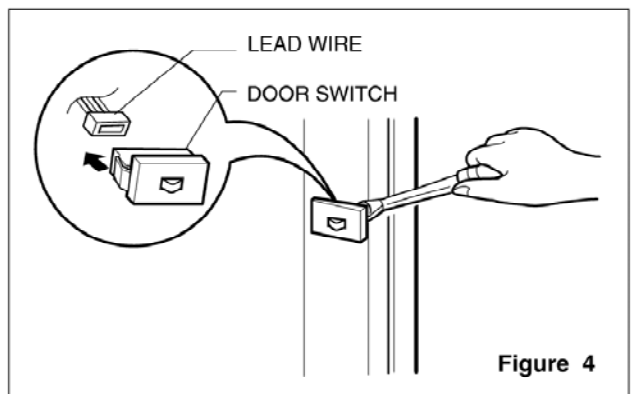

3-3 FAN AND FAN MOTOR

1. Remove the freezer shelf. (If your refrigerator has an icemaker, remove the icemaker first)
2. Remove the grille by pulling it out and by loosening a screw.
3. Remove the Fan Motor assembly by loosening 2 screws and disassemble the shroud.
4. Pull out the fan and separate the Fan Motor and Bracket.

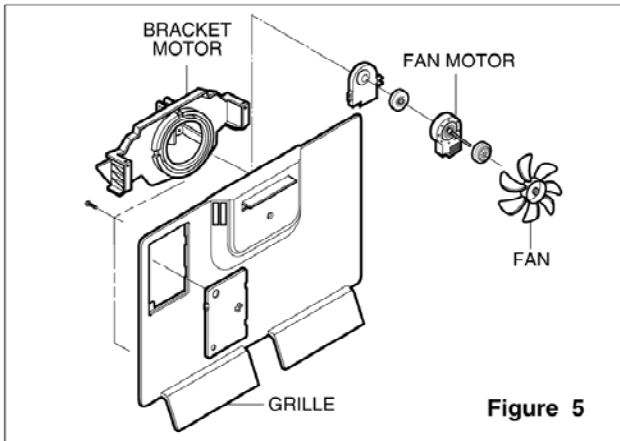

Figure 5

3-4 DEFROST CONTROL ASSEMBLY

Defrost Control assembly consists of Defrost Sensor and FUSE-M.

The Defrost Sensor works to defrost automatically. It is attached to the metal side of the Evaporator and senses its temperature. At 72°C, it turns the Defrost Heater off.

Fuse-M is a safety device for preventing over-heating of the Heater when defrosting.

1. Pull out the grille assembly. (Figure 6)
2. Separate the connector with the Defrost Control assembly and replace the Defrost Control assembly after cutting the Tie Wrap. (Figure 7)

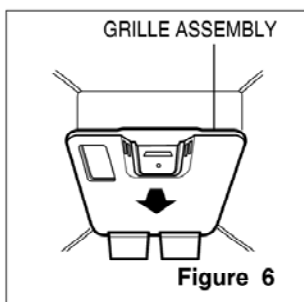

Figure 6

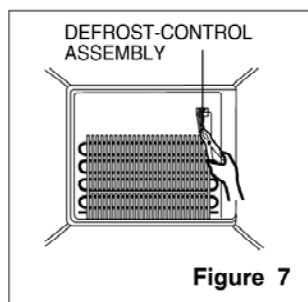

Figure 7

3-5 LAMP

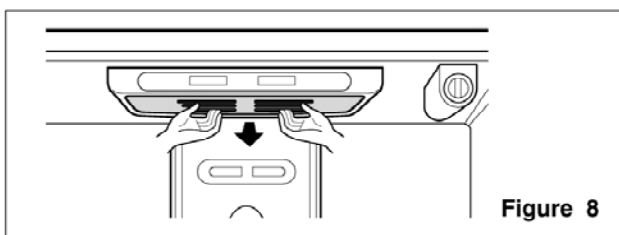

Figure 8

3-5-1 Refrigerator Compartment Lamp

1. Unplug the power cord from the outlet.
2. Remove refrigerator shelves.
3. Release the hooks on both ends of the lamp shield and pull the shield downward to remove it.
4. Turn the lamp counterclockwise.
5. Assemble in reverse order of disassembly. Replacement bulb must be the same specification as the original (Max. 60 W-2EA).

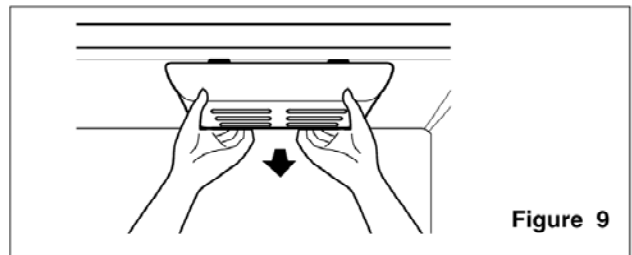

Figure 9

3-5-2 Freezer Compartment Lamp

1. Unplug refrigerator or disconnect power.
2. Reach behind light shield to remove bulb.
3. Replace bulb with a 40-watt appliance bulb.
4. Plug in refrigerator or reconnect power.

3-6 CONTROL BOX-REFRIGERATOR

1. First, remove all shelves in the refrigerator, then remove the Refrigerator control Box by loosening 2 screws.

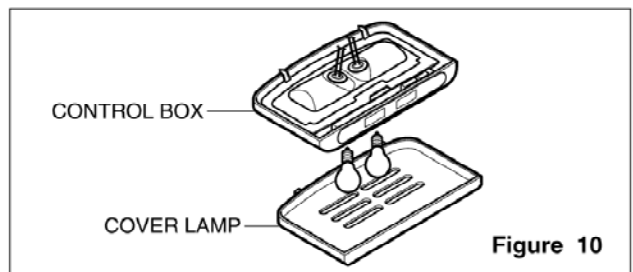

Figure 10

2. Remove the Refrigerator Control Box by pulling it downward.
3. Disconnect the lead wire on the right position and separate the lamp sockets.

3-7 MULTI DUCT

1. Remove an upper and lower Cap by using a flat screwdriver, and loosen 3 screws. (Figure 11)
2. Disconnect the lead wire on the bottom position.

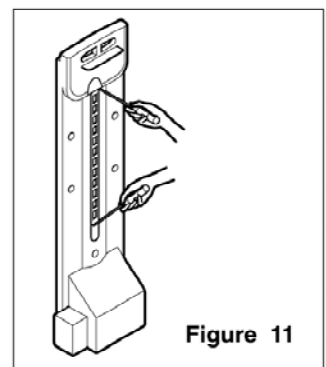

Figure 11

4. ADJUSTMENT

4-1 COMPRESSOR

4-1-1 Role

The compressor intakes low temperature and low pressure gas from the evaporator of the refrigerator and compresses this gas to high-temperature and high-pressure gas. It then delivers the gas to the condenser.

4-1-2 Composition

The compressor includes overload protection. The PTC starter and OLP (overload protector) are attached to the outside of the compressor. Since the compressor is manufactured to tolerances of 1 micron and is hermetically sealed in a dust and moisture-free environment, use extreme caution when repairing it.

4-1-3 Note for Usage

- (1) Be careful not to allow over-voltage and over-current.
- (2) If compressor is dropped or handled carelessly, poor operation and noise may result.
- (3) Use proper electric components appropriate to the Particular Compressor in your product.
- (4) Keep Compressor dry.
If the Compressor gets wet (in the rain or a damp environment) and rust forms in the pin of the Hermetic Terminal, poor operation and contact may result.
- (5) When replacing the Compressor, be careful that dust, humidity, and soldering flux don't contaminate the inside of the compressor. Dust, humidity, and solder flux contaminate the cylinder and may cause noise, improper operation or even cause it to lock up.

4-2 PTC-STARTER

4-2-1 Composition of PTC-Starter

- (1) PTC (Positive Temperature Coefficient) is a no-contact semiconductor starting device which uses ceramic material consisting of BaTiO₃.
- (2) The higher the temperature is, the higher the resistance value. These features are used as a starting device for the Motor.

4-2-2 Role of PTC-Starter

- (1) The PTC is attached to the Sealed Compressor and is used for starting the Motor.
- (2) The compressor is a single-phase induction motor. Durign the starting operation, the PTC allows current flow to both the start winding and main winding.

4-2-3 PTC-Applied Circuit Diagram

● Starting Method for the Motor

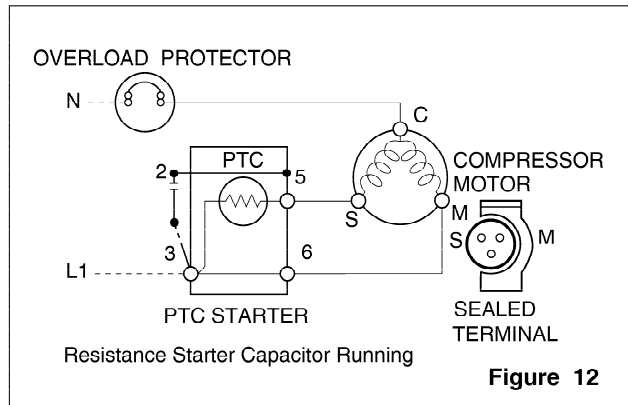

4-2-4 Motor Restarting and PTC Cooling

- (1) It requires approximately 5 minutes for the pressure to equalize before the compressor can restart.
- (2) The PTC device generates heat during operation. Therefore, it must be allowed to cool before the compressor can restart.

4-2-5 Relation of PTC-Starter and OLP

- (1) If the compressor attempts to restart before the PTC device is cooled, the PTC device will allow current to flow only to the main winding.
- (2) The OLP will open because of the over current condition. This same process will continue (3 to 5 times) when the compressor attempts to restart until the PTC device has cooled. The correct OLP must be properly attached to prevent damage to the compressor.

Parts may appear physically identical but could have different electrical ratings. Replace parts by part number and model number. Using an incorrect part could result in damage to the product, fire, injury, or possibly death.

4-2-6 Note for Using the PTC-Starter

- (1) Be careful not to allow over-voltage and over-current.
- (2) Do not drop or handle carelessly.
- (3) Keep away from any liquid.
If liquid such as oil or water enters the PTC, PTC materials may fail due to breakdown of their insulating capabilities.
- (4) If the exterior of the PTC is damaged, the resistance value may be altered. This can cause damage to the compressor and result in a no-start or hard-to-start condition.
- (5) Always use the PTC designed for the compressor and make sure it is properly attached to the compressor. Parts may appear physically identical but could have different electrical ratings. Replace parts by part number and model number. Using an incorrect part could result in damage to the product, fire, injury, or possibly death.

4-3 OLP (OVERLOAD PROTECTOR)

4-3-1 Definition of OLP

- (1) OLP (OVERLOAD PROTECTOR) is attached to the Compressor and protects the Motor by opening the circuit to the Motor if the temperature rises and activating the bimetal spring in the OLP.
- (2) When high current flows to the Compressor motor, the Bimetal works by heating the heater inside the OLP, and the OLP protects the Motor by cutting off the current flowing to the Compressor Motor.

4-3-2 Role of the OLP

- (1) The OLP is attached to the Sealed Compressor used for the Refrigerator. It prevents the Motor Coil from being started in the Compressor.
- (2) For normal operation of the OLP, do not turn the Adjust Screw of the OLP in any way.

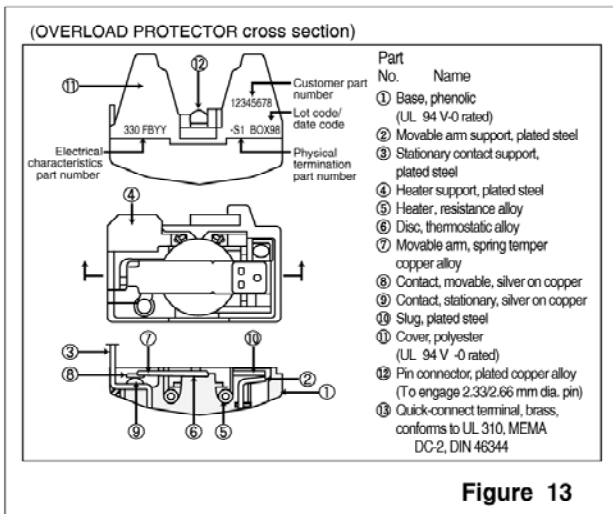
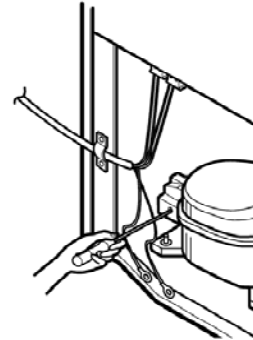
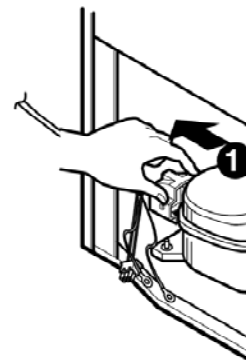

Figure 13

4-4 TO REMOVE THE COVER PTC



- 1) Remove the Cover Back M/C.
- (2) Remove the screw on Cover PTC.



- (3) Remove two Housings on upper part of Cover PTC.
- (4) Take out the cover PTC from upper to lower position like ①.



- (5) Turn 45° in the direction of ② and take it out.
- (6) Assembly in reverse order of disassembly.

5. CIRCUIT DIAGRAM

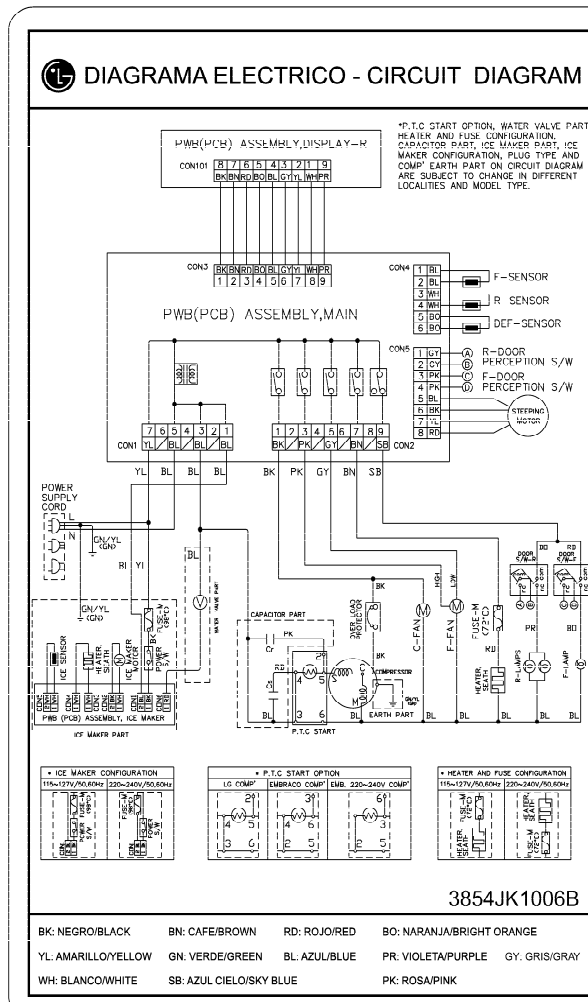
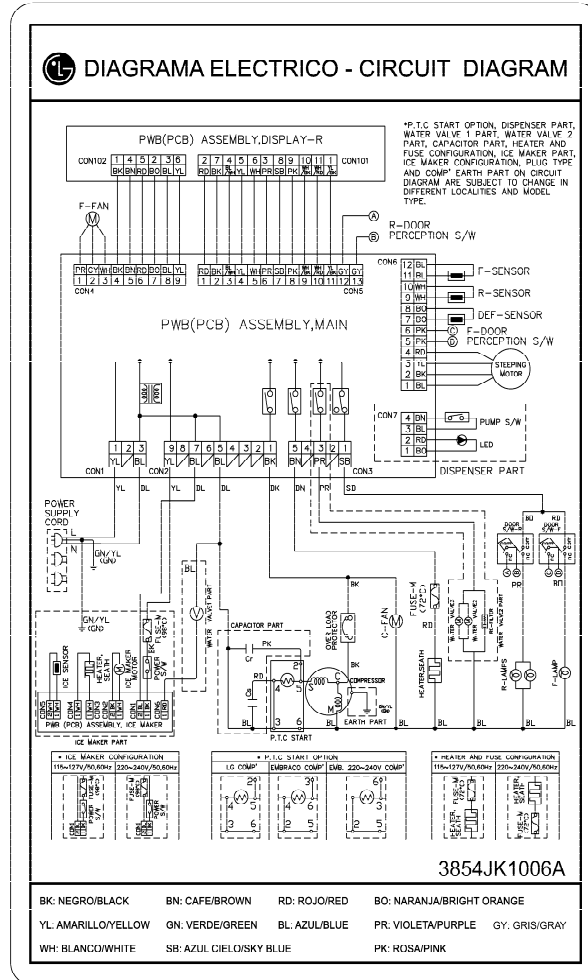

6. TROUBLESHOOTING

6-1 COMPRESSOR AND ELECTRIC COMPONENTS

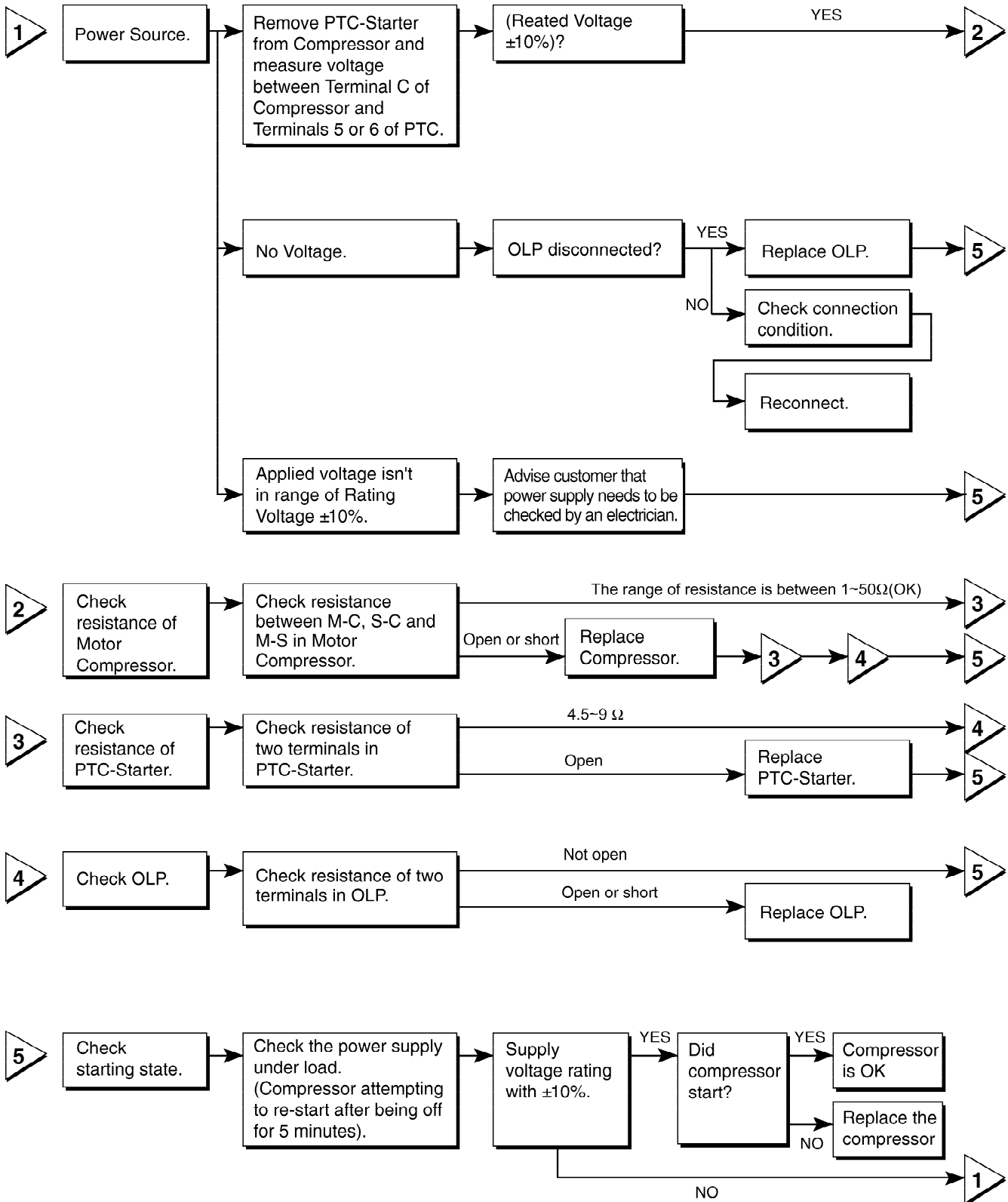

6-2 PTC AND OLP

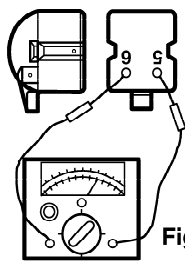
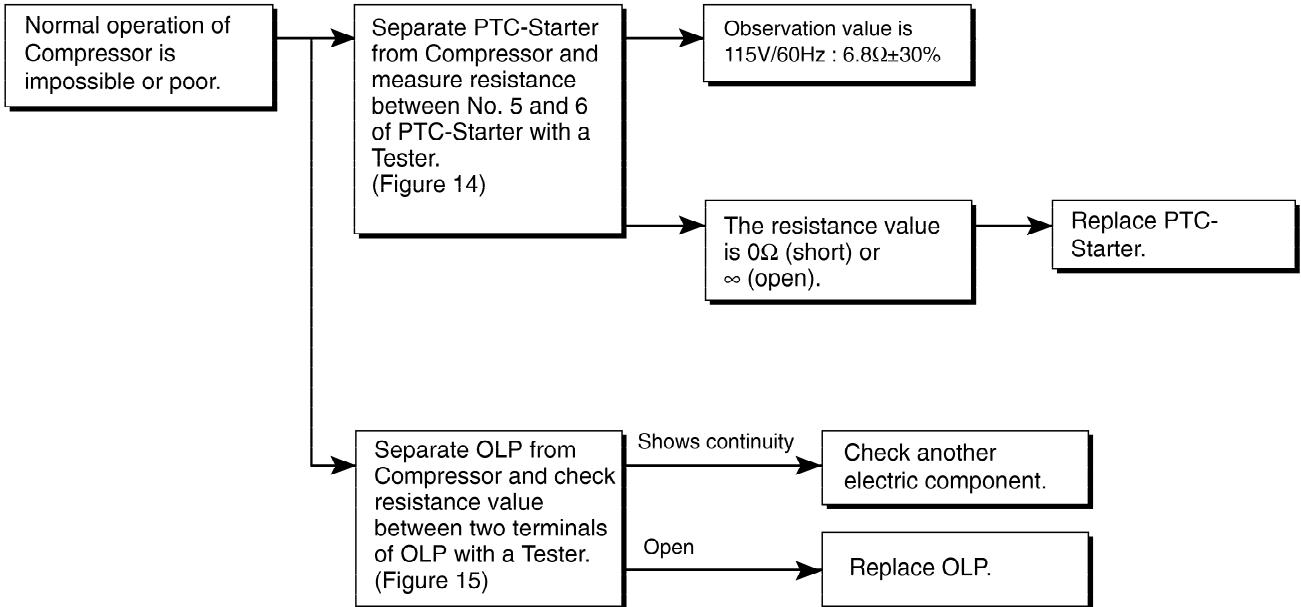

Figure 14

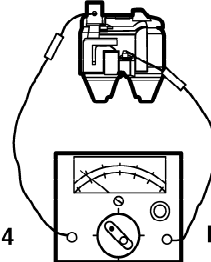
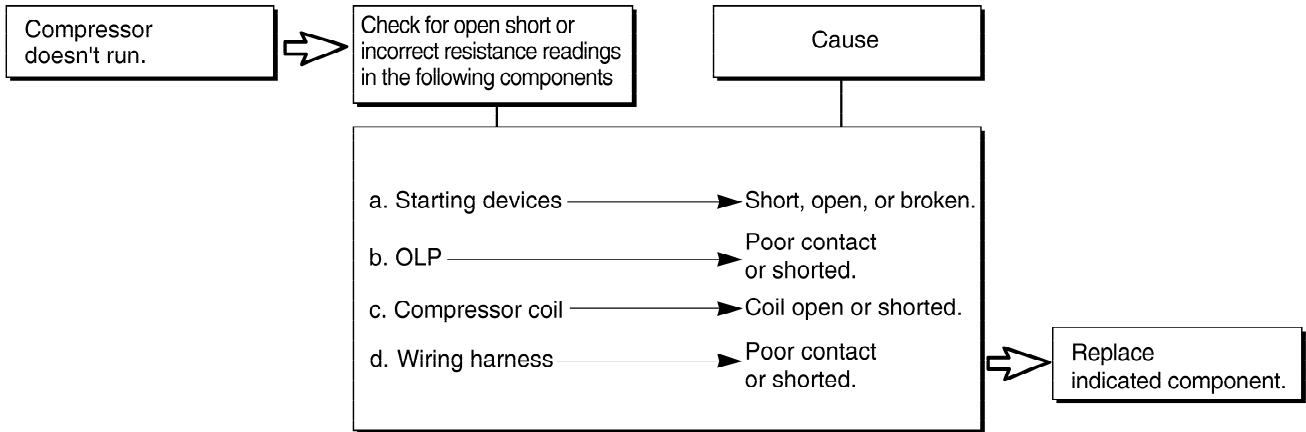

Figure 15

6-3 OTHER ELECTRICAL COMPONENTS

▼ Not cooling at all



▼ Poor cooling performance

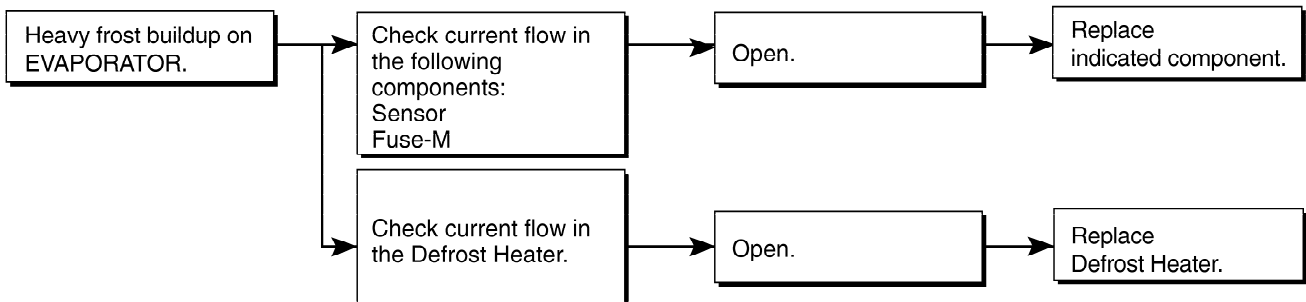
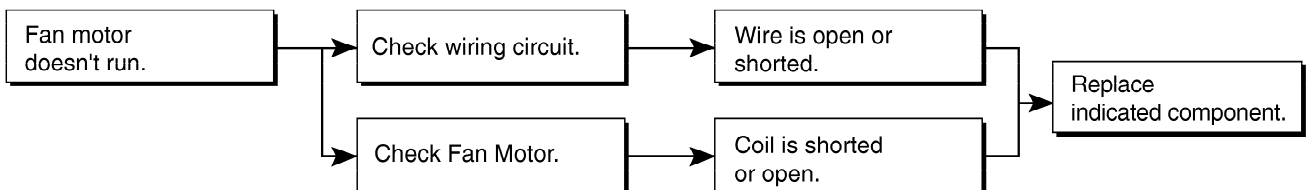
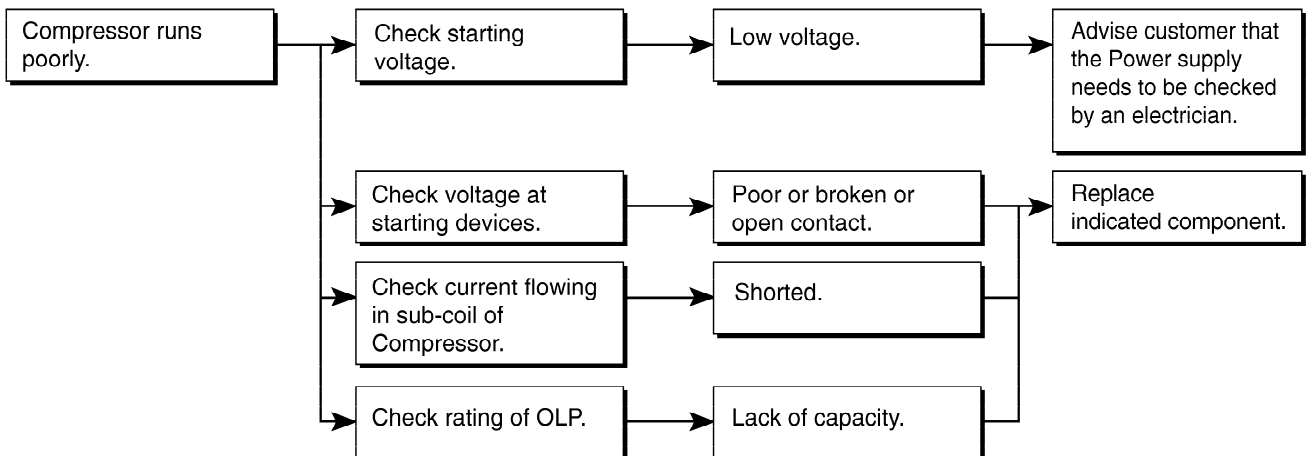

6-4 SERVICE DIAGNOSIS CHART

COMPLAINT	POINTS TO BE CHECKED	REMEDY
No Cooling.	<ul style="list-style-type: none"> • Is the power cord unplugged from the outlet? • Check if the power switch is set to OFF. • Check if the fuse of the power switch is shorted. • Measure the voltage of the power outlet. 	<ul style="list-style-type: none"> • Plug into the outlet. • Set the switch to ON. • Replace the fuse. • If the voltage is low, correct the wiring.
Cools poorly.	<ul style="list-style-type: none"> • Check if the unit is placed too close to the wall. • Check if the unit is placed too close to the stove, gas cooker, or in direct sunlight. • Is the ambient temperature too high or the room door closed? • Check if food put in the refrigerator is hot. • Did you open the door of the unit too often or check if the door is sealed properly? • Check if the Control is set to Warm position. 	<ul style="list-style-type: none"> • Place the unit about 4 inches (10 cm) from the wall. • Place the unit away from these heat sources. • Lower the ambient temperature. • Put in foods after they have cooled down. • Don't open the door too often and close it firmly. • Set the control to Recommended position.
Foods in the Refrigerator are frozen.	<ul style="list-style-type: none"> • Is food placed in the cooling air outlet? • Check if the control is set to colder position. • Is the ambient temperature below 41°F(5°C)? 	<ul style="list-style-type: none"> • Place foods in the high-temperature section. (front part) • Set the control to Recommended position. • Set the control to Warm position.
Condensation or ice forms inside the unit.	<ul style="list-style-type: none"> • Is liquid food sealed? • Check if food put in the refrigerator is hot. • Did you open the door of the unit too often or check if the door is sealed properly? 	<ul style="list-style-type: none"> • Seal liquid foods with wrap. • Put in foods after they have cooled down. • Don't open the door too often and close it firmly.
Condensation forms in the Exterior Case.	<ul style="list-style-type: none"> • Check if the ambient temperature and humidity of the surrounding air are high. • Is there a gap in the door gasket? 	<ul style="list-style-type: none"> • Wipe moisture with a dry cloth. It will disappear in low temperature and humidity. • Fill up the gap.
There is abnormal noise.	<ul style="list-style-type: none"> • Is the unit positioned in a firm and even place? • Are any unnecessary objects placed in the back side of the unit? • Check if the Drip Tray is not firmly fixed. • Check if the cover of the compressor enclosure in the lower front side is taken out. 	<ul style="list-style-type: none"> • Adjust the Leveling Screw, and position the refrigerator in a firm place. • Remove the objects. • Fix the Drip Tray firmly in the original position. • Place the cover in its original position.
Door does not close well.	<ul style="list-style-type: none"> • Check if the door gasket is dirty with an item like juice. • Is the refrigerator level? • Is there too much food in the refrigerator? 	<ul style="list-style-type: none"> • Clean the door gasket. • Position in the firm place and level the Leveling Screw. • Make sure food stored in shelves does not prevent the door from closing.
Ice and foods smell unpleasant.	<ul style="list-style-type: none"> • Check if the inside of the unit is dirty. • Are foods with a strong odor unwrapped? • The unit smells of plastic. 	<ul style="list-style-type: none"> • Clean the inside of the unit. • Wrap foods that have a strong odor. • New products smell of plastic, but this will go away after 1-2 weeks.

● Other possible problems:

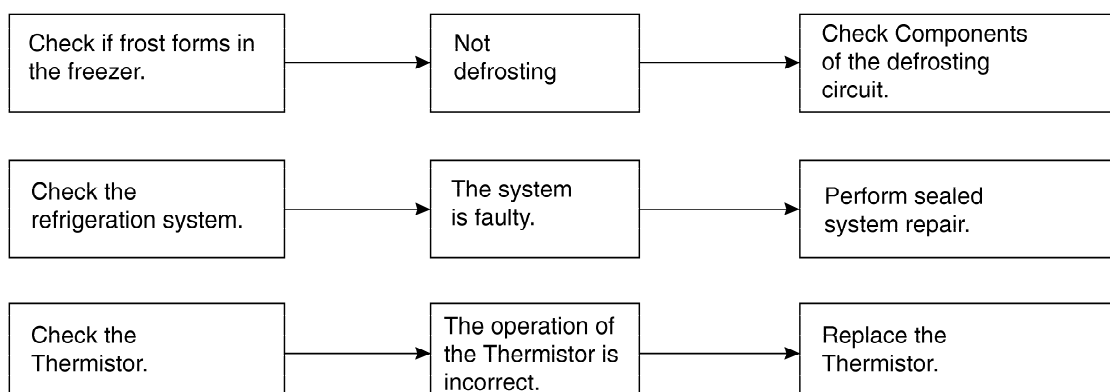

6-5 REFRIGERATION CYCLE

▼ Troubleshooting Chart

CAUSE		STATE OF THE UNIT	STATE OF THE EVAPORATOR	TEMPERATURE OF THE COMPRESSOR	REMARKS
LEAKAGE	PARTIAL LEAKAGE	Freezer compartment and Refrigerator don't cool normally.	Low flowing sound of Refrigerant is heard and frost forms in inlet only.	A little higher than ambient temperature.	<ul style="list-style-type: none"> Refrigerant level is low due to a leak. Normal cooling is possible by restoring the normal amount of refrigerant and repairing the leak.
	COMPLETE LEAKAGE	Freezer compartment and Refrigerator don't cool normally.	Flowing sound of refrigerant is not heard and frost isn't formed.	Equal to ambient temperature.	<ul style="list-style-type: none"> No discharging of Refrigerant. Normal cooling is possible by restoring the normal amount of refrigerant and repairing the leak.
CLOGGED BY DUST	PARTIAL CLOG	Freezer compartment and Refrigerator don't cool normally.	Flowing sound of refrigerant is heard and frost forms in inlet only.	A little higher than ambient temperature.	<ul style="list-style-type: none"> Normal discharging of the refrigerant. The capillary tube is faulty.
	WHOLE CLOG	Freezer compartment and Refrigerator don't cool.	Flowing sound of refrigerant is not heard and frost isn't formed.	Equal to ambient temperature.	<ul style="list-style-type: none"> Normal discharging of the Refrigerant.
MOISTURE CLOG		Cooling operation stops periodically.	Flowing sound of refrigerant is not heard and frost melts.	Lower than ambient temperature.	<ul style="list-style-type: none"> Cooling operation restarts when heating the inlet of the capillary tube.
DEFECTIVE COMPRESSION	COMP-RESSION	Freezer and Refrigerator don't cool.	Low flowing sound of refrigerant is heard and frost forms in inlet only.	A little higher ambient temperature.	<ul style="list-style-type: none"> Low pressure at high side of compressor due to low refrigerant level.
	NO COMP-RESSION	No compressing operation.	Flowing sound of refrigerant is not heard and there is no frost.	Equal to ambient temperature.	<ul style="list-style-type: none"> No pressure in the high pressure part of the compressor.

▼ Leakage Detection

- Observe the discharging point of the refrigerant, which may be in the oil discharging part of the compressor and in a hole in the evaporator.

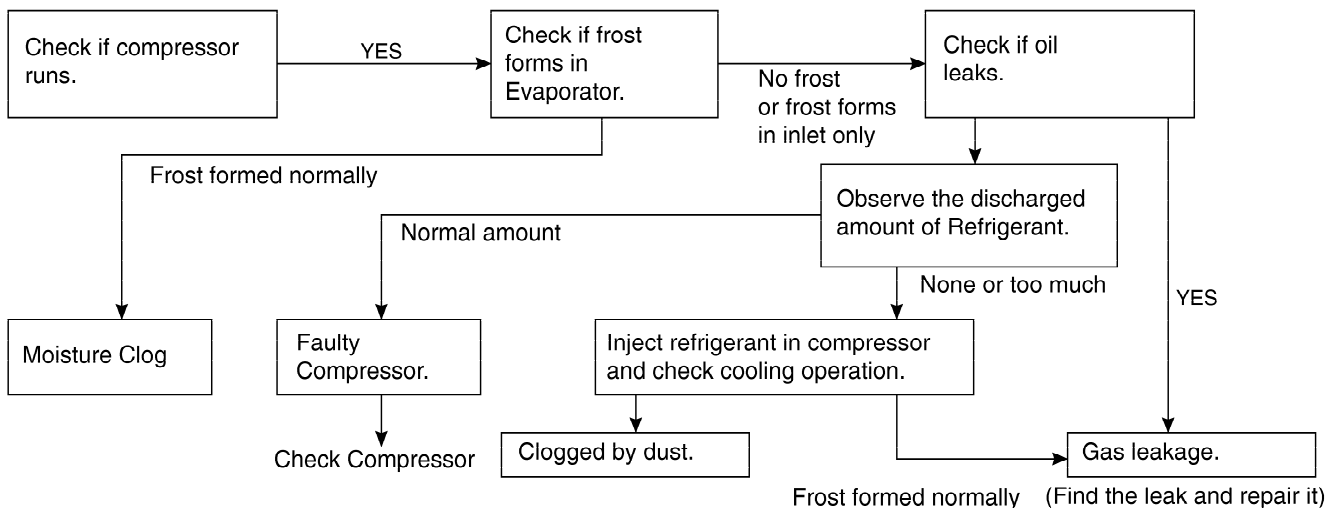

▼ General Control of Refrigerating Cycle

NO.	ITEMS	UNIT	STANDARDS	PURPOSES	REMARKS	
1	Pipe and piping system opening time	Min.	Pipe: within 1 hour. Comp: within 10 minutes. Drier: within 20 minutes.	To protect moisture penetration.	The opening time should be reduced to a half of the standards during rain and rainy seasons (the penetration of water into the pipe is dangerous).	
2	Welding	Nitrogen pressure	Weld under Nitrogen atmosphere. (N ₂ pressure: 0.1~0.2 kg/cm ²)	To protect oxide scale formation.	- Refer to repair note in each part. - R-134a refrigerant is more susceptible to leaks than R-12 and requires more care during welding. - Do not apply force to pipes before and after welding to protect pipe from cracking.	
3	N ₂ sealed parts	Confirm N ₂ leak	Confirm the sound of pressure relief when removing the rubber cap. Sound: usable No sound: not usable	To protect moisture penetration.	- In case of evaporator parts, if it doesn't make sound when removing rubber cap, blow dry air or N ₂ gas for more than 1 min. and then use the parts.	
4	Refrigeration Cycle	Evacuation time	Min.	More than 40 minutes	To remove moisture.	
		Vacuum degree	Torr	Below 0.03 (ref)		Note: Only applicable to the model equipped with reverse flow protect plate.
		Vacuum	EA	High and low pressure sides are evacuated at the same time for models above 200 l.		Vacuum efficiency can be improved by operating compressor during evacuation.
		Vacuum piping	EA	Use R-134a manifold exclusively.	To protect mixing of mineral and ester oils.	The rubber pipes for R-12 refrigerant will be melted when they are used for R-134a refrigerant (causes of leak.)
		Pipe coupler	EA	Use R-134a manifold exclusively.	To protect R-12 refrigerant mixing.	
		Outlet (Socket)		R-134a manifold exclusively.	To protect R-12 refrigerant mixing.	
		Plug		R-134a manifold exclusively.	To protect R-12 refrigerant mixing.	
5	Refrigerant weighing	EA	Use R-134a exclusively. Weighing allowance: ±5g Note: Winter: -5g Summer: +5g	Do not mix with R-12 refrigerant.	- Do not weigh the refrigerant at too hot or too cold an area. (77°F [25°C] is adequate.) - Make Copper charging canister (Device filling refrigerant) Socket: 2SV Plug: 2PV R-134a Note: Do not burn O-ring (bushing) during welding.	
6	Drier replacement		- Use R-134a exclusively for R-134a refrigerator. - Replace drier whenever repairing refrigerator cycle piping.	To remove the moisture from pipe inside.		
7	Leak check		- Do not use soapy water for check. It may be sucked into the pipe by a vacuum.	Defect in refrigerant leak area.	- Check for an oil leak at the refrigerant leak area. Use an electronic leak detector if an oil leak is not found. - The electronic leak detector is very sensitive to halogen gas in the air. It also can detect R-141b in urethane. Practice many times before using this type of detector to avoid false readings.	

7. OPERATION PRINCIPLE AND REPAIR METHOD OF ICEMAKER

7-1 OPERATION PRINCIPLE

7-1-1 Operation Principle of IceMaker

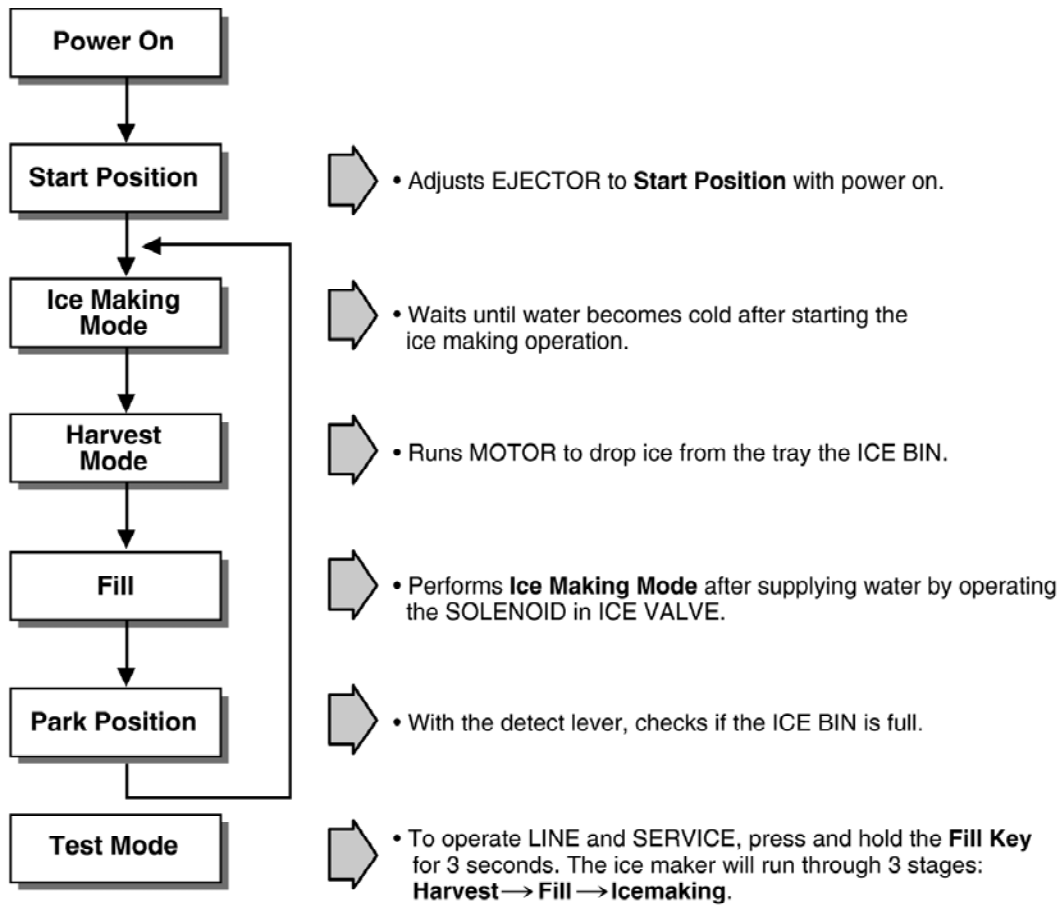

1. Turning the Icemaker stop switch off (O) stops the ice making function.
2. Setting the Icemaker switch to OFF and then turning it back on will reset the icemaker control.

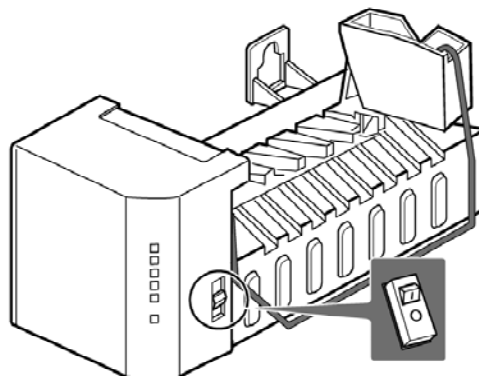

7-2 CONTROL METHOD ACCORDING TO FUNCTIONS

7-2-1 Start Position

1. After POWER OFF or Power Outage, check the EJECTOR's position with MICOM initialization to restart.
2. How to check if it is in place:
 - Check **HIGH/LOW** signals from HALL SENSOR in MICOM PIN.
3. Control Method to check if it is in place:
 - (1) EJECTOR is in place,
 - It is an initialized control, so the mode can be changed to ice making control.
 - (2) EJECTOR isn't in place:
 - A. If EJECTOR is back in place within 2 minutes with the motor on, it is being initialized. If not, go to Step B.
 - B. If EJECTOR is back in place within 18 minutes with the heater on (to control Heater on its OFF condition), it is being initialized. If not, it is not functioning. Repeat Step B with Heater and Motor off.

7-2-2 Ice Making Mode

1. Ice Making control refers to the freezing of supplied water in the ice trays. Complete ice making operations by measuring the temperature of the Tray with Ice-Making SENSOR.
2. Ice Making starts after completing fulfilled ice control and initial control.
3. The Ice Making function is completed when the sensor reaches 19°F(-7°C), 60 to 240 minutes after starting.
4. If the temperature sensor is defective, the ice-making function will be completed in 4 hours.

7-2-3 Harvest Mode

1. Ice-removing control refers to the operation of dropping cubes into the ice bin from the tray when ice-making has completed.
2. Ice removing control mode:
 - (1) Operates Heater for 30 seconds; then operate MOTOR.
 - (2) After performing Step 1 (to control the Heater on its off condition), Ice-Removal control will be back in place within 18 minutes. (Hall SENSOR sign = OV). Ice removal is then complete. Then change the mode to the water supply control. If this control phase fails to start, it is not functioning. Put the Heater and Motor in the off position. Restart every 2 hours. (Refer to fig.1)



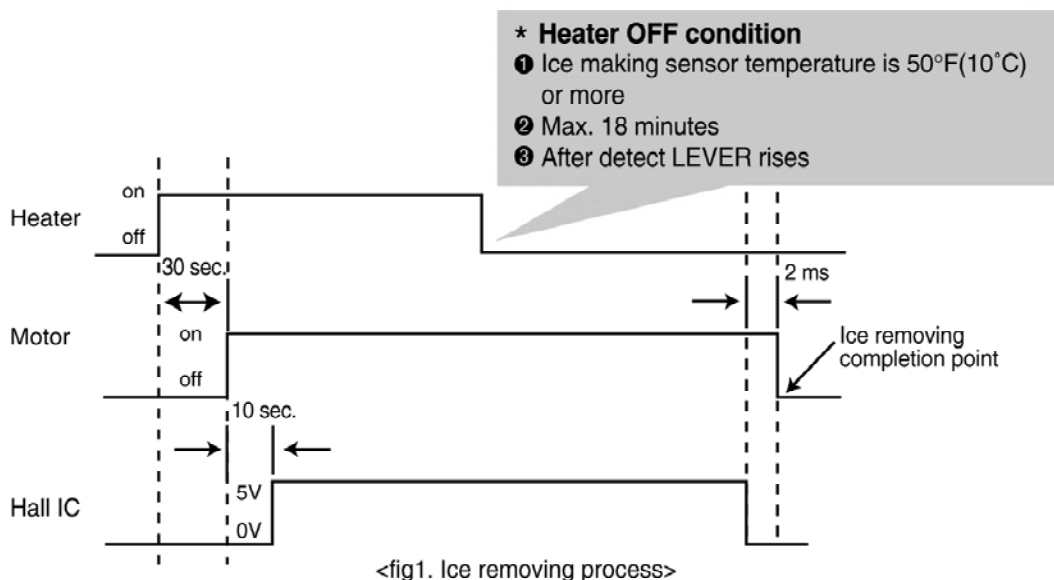

NOTE : If the motor malfunctions and starts before the detect lever rises, MICOM regards the Ice-Removing phase as completed. Water then starts flowing. To prevent this, MICOM doesn't switch to water-supply mode, but restarts the ice-removing mode. If this happens 3 times, the motor is malfunctioning and you should stop the loads (Heater, Motor). Then restart the Ice-Removing mode every 2 hours. (See Step 2 above.)



7-2-4 Fill / Park Position

1. When Ice-Removing control (Normal Ice-Removing control, Ice-Removing control for test) has completed, and the EJECTOR is in place, this control operates the ICE SOLENOID by time check in the compressor enclosure of the refrigerator. Then it supplies water to the ice making tray.
2. Water supply level is adjustable in levels 1-5 by pressing the water supply control Switch and fill time will be determined by the selected level.

Water supply amount TABLE

STAGE	TIME TO SUPPLY	INDICATIONS	REMARKS
1	6 sec.		The water amount will vary depending on the water control Switch setting, as well as the water pressure of the connected water line.
2	7 sec.		
3	8 sec.		
4	9 sec.		
5	10 sec.		



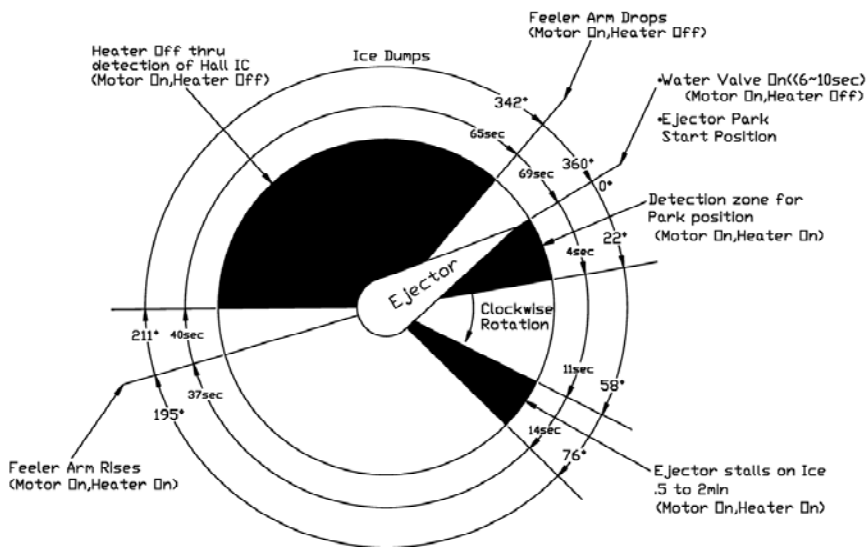

NOTE : Below is an example used by another vendor as an explanation of what is taking place.



7-2-5 Function TEST



1. This is a compulsory operation for TEST, SVC, cleaning, etc. It is operated by pressing the water supply control KEY for 3 seconds.
2. It operates in the Ice Making mode, but not in the Ice-Removing mode or water supply process. (If there is an ERROR, it can only be checked in the TEST mode.)
3. If the water supply control KEY is pressed for 3 seconds in the Ice-Making mode (no matter what condition the Ice-Making tray is in) the Ice-Removing operation starts immediately. Water is not yet frozen, so water is poured instead of ice. If the control doesn't operate normally in the TEST mode, check and repair as needed.
4. After water is supplied, the normal CYCLE is followed: **ice making** → **Harvest** → **Fill** → **Park Position**.
5. When Stage 5 is completed in the TEST mode, minimize MICOM in 5 seconds, the time needed to supply water resets to the previous status in the TEST mode.

Diagnosis TABLE

STAGE	ITEMS	INDICATOR	REMARKS
1	HEATER		Five seconds after heater starts, heater will go off if temperature recorded by sensor is 10°C or lever is in up position.
2	MOTOR		Five seconds after heater starts, you can confirm that motor is moving.
3	HALL IC (detection of position) I		You can confirm Hall IC detection of position.
4	VALVE		Two seconds after detection of initial position, you can confirm that valve is on.
5	HALL IC (detection of full-filled Ice) II		You can check whether hall is sensing Full ice condition. (If there is a full-filled error, the fifth LED is not on.)
6	reset	Mark previous status on TEST mode	Five seconds after fifth stage is completed, the icemaker reset at initial status.

7-3 DEFECT DIAGNOSIS FUNCTION

7-3-1 ERROR CODES shown on Ice Maker water supply control panel

NO	DIVISION	INDICATOR	CONTENTS	REMARKS
1	Normal	Mark time to supply	None	Display switch operates properly
2	Ice-Making Sensor malfunction		Cut or short-circuited wire	Make sure that the wire on each sensor is connected.
3	Ice Maker Kit malfunction		When ejector blades don't reach park position over 18 minutes since Harvest Mode starts.	Defects of HALL IC/MOTOR/HEATER/RELAY

ERROR indicators in table can be checked only in TEST mode.

8 WATER FILTER

8.1 WATER FILTER CARTRIDGE REPLACEMENT

FILTER (on some models)

It is recommended that you replace the filter when the water filter indicator light turns on or your water dispenser or ice maker decreases noticeably.

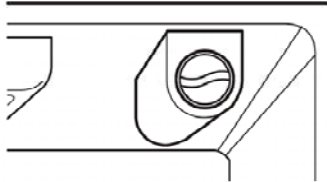

After changing the water filter cartridge, reset the water filter status display and indicator light by pressing and holding the **BUTTON** for 3 seconds.

How to change the old cartridge.

1. Turn the shutoff valve off (house valve).*



2. Dispense water from the system to empty the tubing (approximately for 50 seconds).*



3. Remove the old cartridge.

Rotate the knob of the cartridge counter clockwise.



When the cartridge is removed, it will click out of place.



NOTE: There will be water in the cartridge. Some spilling may occur through the hole at rear bottom side of cover. You may use a cup or something like that to prevent spilt water drop into food.

Pull out the cartridge.



4. Replace with a new cartridge.

Take the new cartridge out of its packaging and remove protective cover from the o-rings.

With cartridge knob in the vertical position, push the new filter cartridge into the cover until it stops.

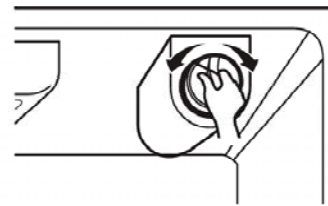

If you can't turn the filter from side to side, it isn't inserted. Push it in firmly and twist it into place. You will hear it click into place.

Using its handle, twist the cartridge clockwise about 1/4 turn. You will hear when it clicks into place.

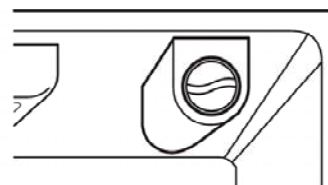
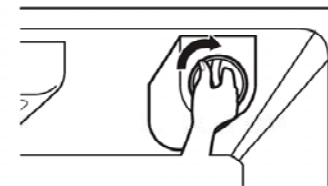

5. Turn the shutoff valve on (house valve).*

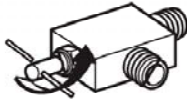

NOTE: To purchase replacement water filter cartridges, visit your local appliance dealer or part distributor. You can also visit our website : www.lgappliances.com or call 1-877-714-7481.

6. Flush water out from the system until air gets eliminated and water start to dispense (approximately for 60 seconds).*



*Steps 1,2,5 & 6 only for models with water dispenser.

8.2 WATER DISPENSER(On some models)

WATER DISPENSER

2. Tilt up the front of tray slightly and snap the ribs into the holes to replace the tray.

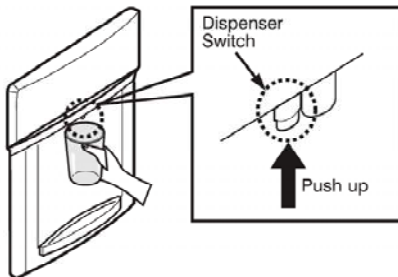

1. Push up the dispenser switch with a cup until you hear click to get cold water.
Tray can be easily removed by pressing and pulling it.

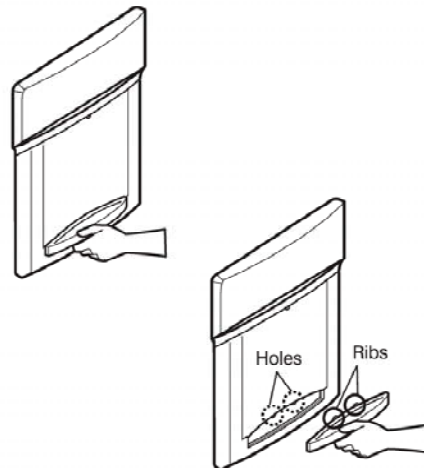

Important: If no water dispensed when the refrigerator is first installed, there may be air in the water line system. Press the dispenser switch for at least two minutes to remove trapped air from the water line and to fill the water system.

9. DESCRIPTION OF FUNCTION & CIRCUIT OF MICOM

9-1 FUNCTION

9-1-1 Function

1. When the appliance is plugged in, it is set to 37 °F for the Refrigerator and 0 °F for the Freezer.
You can adjust the Refrigerator and the Freezer control temperature by pressing the COLDER button or the WARMER button.
2. When the power is initially applied or restored after a power failure, it is set to the setting temperature as you set before power off. (applied to DISPENSER MODEL)

DISPENSER MODEL

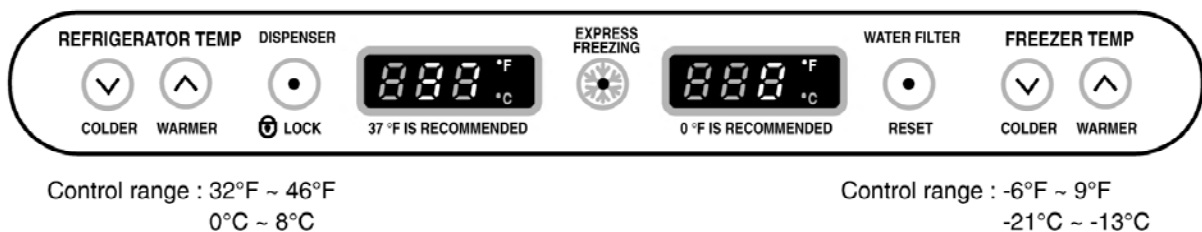

BEST MODEL

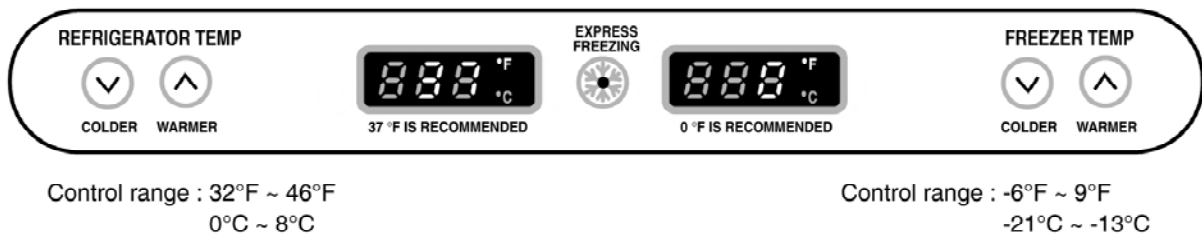

9-1-2 How to Change the Temperature Mode to °F / °C

1. The setting temperature mode can be changed to °F / °C by pressing and holding COLDER key of Freezer and COLDER key of Refrigerator over 1 seconds. at the same time.
2. The initial setting is °F. Whenever the mode is changed, the LED lights are changed.

9-1-3 Dispenser Lock

1. Press and hold the DISPENSER LOCK button for 3 seconds to lock the dispenser.
2. When locked, the LED is off and the dispenser function is turned off.
3. Press and hold the DISPENSER LOCK button again for 3 seconds to unlock the dispenser. The LED will be on and the dispenser will function normally.

9-1-4 CONTROL OF FREEZER FAN MOTOR

1. Freezer fan motor has high and standard speeds.
2. High speed is used at power-up, for express freezing, and when refrigerator is overloaded.
Standard speeds is used for general purposes.
3. To improve cooling speed, the RPM of the freezer fan motor change from normal speed to high.
4. High speed (2700RPM) : Initial power on or load corresponding operation, express freezing.
Normal speed (2400RPM) : General working conditions.
5. Fan motor stops when refrigerator or freezer door opens.

9-1-5 EXPRESS FREEZING

1. The purpose of this function is to intensify the cooling speed of freezer and to increase the amount of ice.
2. Whenever selection switch is pressed, selection/release, the LED will turn ON or OFF.
3. If there is a power cutage and the refrigerator is power on again, EXPRESS FREEZING function will be canceled.
4. To activate these function, to press the Express Freezing key and the LED will turn ON. This function will remain activated for 24 hrs. The first three hours the compressor and Freezer Fan will be ON. The next 21 hours the freezer will be controlled at the lowest temperature. After 24 hours or if the Express Freezing key is pressed again, the freezer will return to its previous temperature.
5. For the first three hours notice the following cases:
 - (1) Compressor and freezer fan (HIGH RPM) continuously operate for three hours.
 - (2) If defrost starts during EXPRESS FREEZING, EXPRESS FREEZING operates for the rest of time after defrost is completed, when EXPRESS FREEZING operation time is less than 90 minutes.
If EXPRESS FREEZING operates for more than 90 minutes, the EXPRESS FREEZING will operate for two hours after defrost is completed.
 - (3) If EXPRESS FREEZING is pressed during defrost, EXPRESS FREEZING LED is on but this function will start seven minutes after defrost is completed and it shall operate for three hours.
 - (4) If EXPRESS FREEZING is selected within seven minutes after compressor has stopped, the compressor (compressor delays seven minutes) shall start after the balance of the delay time.
 - (5) The fan motor in the freezer compartment runs at high speed during EXPRESS FREEZING .
6. For the rest of the 21 hours, the freezer will be controlled at the lowest temperature.

9-1-6 REFRIGERATOR LAMP AUTO OFF

1. To avoid heat damage caused by the lamp, it is turned off automatically when the refrigerator door is open for more than 7 minutes.

9-1-7 Alarm for Open Door

1. This feature sounds a buzzer when the freezer or refrigerator door is not closed within 1 minute after it is opened.
2. One minute after the door is opened, the buzzer sounds three times each for 1/2 seconds. These tones repeat every 30 seconds.
3. The alarm is cancelled when the freezer or the refrigerator is closed while the buzzer sounds.

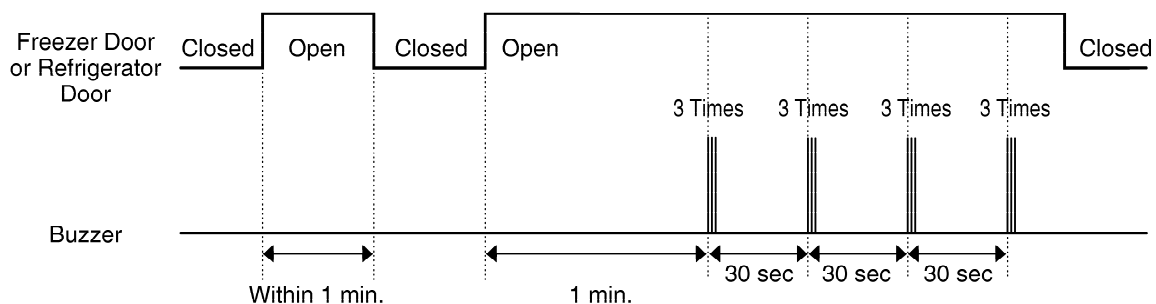

9-1-8 Buzzer Sound

When the button on the front Display is pushed, a Ding~ Dong~ sound is produced.
(Refer to the Buzzer Circuit 8-2-4 No. 3)

9-1-9 Defrosting (removing frost)

1. Defrosting starts each time the COMPRESSOR running time reaches 7 hours.
2. For initial power on or for restoring power, defrosting starts when the compressor running time reaches 4 hours.
3. Defrosting stops if the sensor temperature reaches 46.4°F(8°C) or more. If the sensor doesn't reach 46.4°F(8°C) in 2 hours, the defrost mode is malfunctioning. (Refer to the defect diagnosis function, 8-1-13.)
4. Defrosting won't function if its sensor is defective (wires are cut or short circuited)

9-1-10 Filter Replacement Indication

1. In 6 months after the UNIT (refrigerator) is power on, or after 28,000 seconds of dispenser use, the water filter Indicator LED (red color) will be ON.
2. When the water filter indicator LED is illuminated, you should change the water filter. After this, you must press the water filter button for three seconds and you will hear a ding-dong sound.
The LED will be OFF. This operation will indicate that the UNIT is reset to its initial conditions, so this process is restarted.

9-1-11 Power Failure Compensation Function

1. When the UNIT is power off, the Fresh Food and Freezer Temperature notches, the filter elapsed time for replacement, the temperature mode (°C or °F) and the dispenser lock mode are saved in the EEPROM.
2. When the UNIT is power on, the MICOM will read the specified EEPROM addresses to restore the values indicated in the previous paragraph.

9-1-12 Electrical Parts Are Turned On Sequentially

Electrical parts such as COMP, defrosting heater, freezer FAN, etc. are turned on in the following order to prevent noise and parts damage. Several parts are started at the same time at initial power on and are turned off together when TEST is completed.

OPERATING		ORDERS				
Initial power on	Temperature of Defrosting Sensor is 113°F(45°C) or more (when unit is newly purchased or when moved)	POWER ON	in 1/2 second →	COMP ON	in 1/2 second →	Freezer FAN ON
	Temperature of defrosting sensor is lower than 113°F(45°C) (when power cuts, SERVICE)	POWER ON	in 1/2 second →	Defrosting heater ON	in 10 second →	Defrosting heater OFF
		in 1/2 second →	COMP ON	in 1/2 second →	Freezer FAN ON	
Reset to normal operation from TEST MODE		Total load OFF	in 7 minute →	COMP ON	in 1/2 second →	Freezer FAN ON

9-1-13 Defect Diagnosis Function

1. Automatic diagnosis makes servicing the refrigerator easy.
2. When a defect occurs, the buttons will not operate; but the tones, such as ding, will sound.
3. When the defect CODE removes the sign, it returns to normal operation (RESET).
4. The defect CODE shows on the Refrigerator and Freezer Display.

DISPENSER MODEL

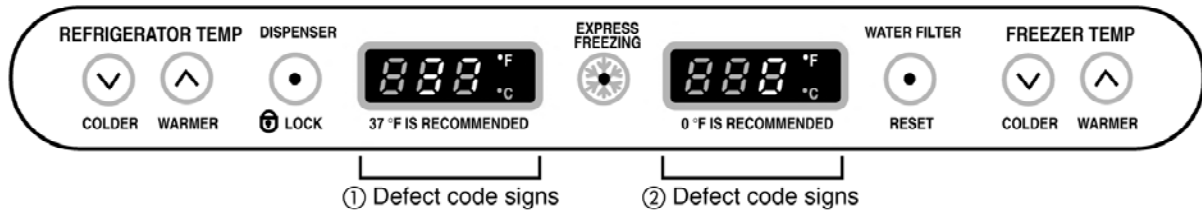

BEST MODEL

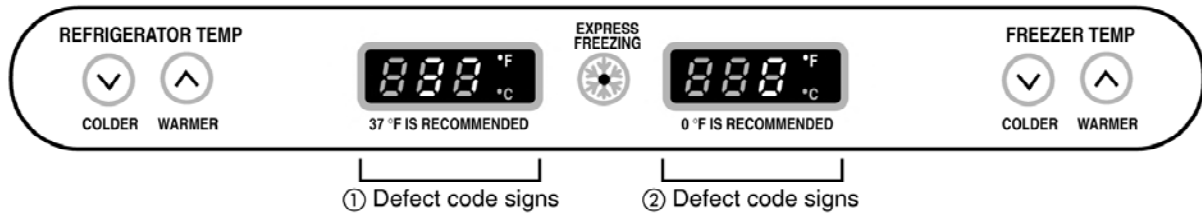

ERROR CODE on display panel

NO	ITEM	ERROR CODE		CONTENTS	REMARKS
		①	②		
1	Failure of freezer sensor	<i>Er</i>	<i>FS</i>	Cut or short circuit wire	Inspect Connecting wires on each sensor
2	Failure of Refrigerator sensor	<i>Er</i>	<i>rS</i>	Cut or short circuit wire	
3	Failure of defrost sensor	<i>Er</i>	<i>dS</i>	Cut or short circuit wire	
4	Failure of defrost mode	<i>Er</i>	<i>dH</i>	When defrost sensor doesn't reach 8°C within 2 hours after starting defrost.	Snapping of defrost heater or Temperature fuse, pull-out of Connector (indicated minimum 2 Hours after failure occurs)
5	Failure of BLDC FAN MOTOR at freezing compartment.	<i>Er</i>	<i>FF</i>	If there is no fan motor signal For more than 65sec. in Operation fan motor	Poor motor, hooking to Wires of fan, contact of structures to fan, snapping or short circuit of Lead wire

9-1-14 TEST Mode

1. The Test mode allows checking the PCB and the function of the product as well as finding out the defective part in case of an error.
2. The test mode is operated by pressing two buttons at Display panel.
3. While in the test mode, the function control button is not recognized, but the recognition tone (beep~) sounds.
4. After exiting the test mode, be sure to reset by unplugging and then plugging in the appliance.
5. If an error, such as a sensor failure, is detected while in the test mode, the test mode is cleared and the error code is displayed.
6. While an error code is displayed, the test mode will not be activated.

MODE	MANIPULATION	CONTENTS	REMARKS
TEST1	Push Express Freezing key and COLDER KEY of Freezer Temp. at the same time over 3 seconds.	<ol style="list-style-type: none"> 1. Continuous operation of the COMPRESSOR 2. Continuous operation of the freezer fan 3. STEPPING DAMPER OPEN 4. Defrosting Heater OFF 5. Every DISPLAY LED ON 	
TEST2	Push Express Freezing key and COLDER KEY of Freezer Temp. at the same time over 3 seconds in TEST MODE 1	<ol style="list-style-type: none"> 1. COMP OFF 2. Freezer FAN OFF 3. STEPPING DAMPER CLOSE 4. Defrosting heater ON 5. DISPLAY LED shows 222 	Reset if the temperature of the Defrosting sensor is 46°F(8°C) or more.
Reset	Push Express Freezing key and COLDER KEY of Freezer Temp. at the same time over 3 seconds. in TEST MODE 2	Reset to the previously setting before TEST MODE	The compressor will Start after a 7-minute delay.

NOTE : LED CHECK MODE: When the WARMER button in the refrigerator temperature control and the WARMER button in the freezer temperature control are pushed and held for 1 second or longer, every LED on the display turns on at the same time. When the buttons are released, the previous mode is restored.

* Freezer Fan RPM Variable Check:

In case the freezer fan is in operation when the WARMER KEY in Refrigerator and Freezer Temp. Control are pressed for more than one second at the same time freezer fan RPM changes. (for example if high speed, to normal speed or if normal speed, to high speed for 30 seconds)
After 30 seconds, it turns to its original RPM.

* Demonstration MODE:

1. When the WARMER KEY of refrigerator Temp. control or of freezer Temp. control in the the warmest temperature's status are pushed and held for 3 seconds or longer, It converts to Demonstration Mode.
2. It shows **OFF** on the display panel.
3. In this status, all Loads are off (Compressor / Fan / Damper / Heater)
(Even is Demonstration Mode, the refrigerator Lamp automatic off function works normally and can be demonstrated)
4. Exit the test mode and reset the display by pressing the COLDER and WARMER buttons.

9-2 PCB FUNCTION

9-2-1 Power Circuit

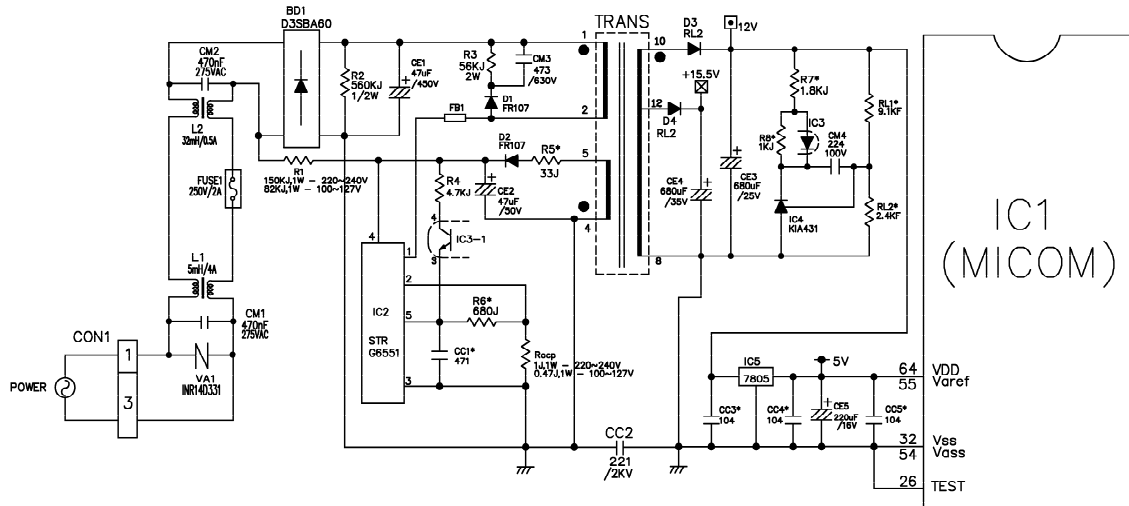

The secondary part of the TRANSFORMER is composed of the power supply for the display, the BLDC FAN Motor drive (15.5 V), the relay drive (12 Vdc) and the MICOM and IC (5 Vdc).

The voltage for each part is as follows:

PART	VA 1	CE 3	CE 4	CE 5
VOLTAGE	115 Vac	12 Vdc	15.5 Vdc	5 V

VA1 is a part for preventing over voltage and noise. When 385V or higher power is applied, the inside elements are short-circuited and broken, resulting in blowout of the fuse in order to protect the elements of the secondary part of the TRANSFORMER.

9-2-2 Oscillation Circuit

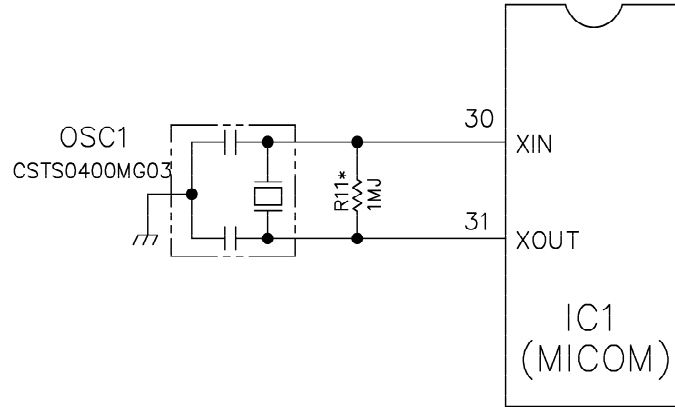

This circuit generates the base clock for calculating time and the synchro clock for transmitting data from and to the inside logic elements of the IC1 (MICOM). Be sure to use specific replacement parts, since calculating time by the IC1 may be changed. If changed, the OSC1 SPEC will not work.

9-2-3 Reset Circuit

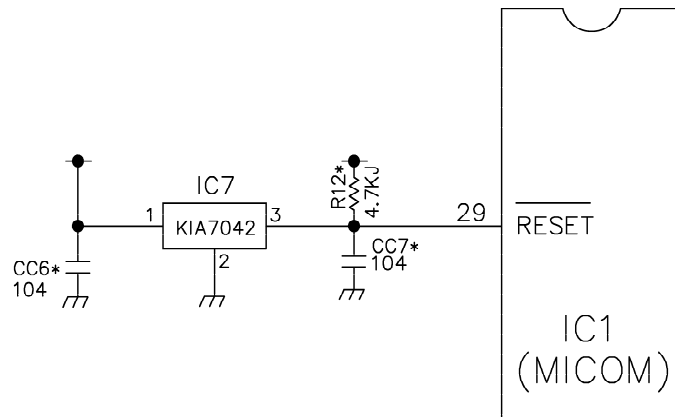

The RESET circuit allows all the functions to start at the initial conditions by initializing various parts, including the RAM inside the MICOM (IC1) when the power is initially supplied or the power supply to the MICOM is restored after a momentary power failure. For the initial 10ms of power supply, LOW voltage is applied to the MICOM RESET terminal. During a normal operation, 5V is applied to the RESET terminal. (If a malfunction occurs in the RESET IC, the MICOM will not operate.)

9-2-4 Load / Buzzer Drive & Open Door Detection Circuit

1. Load Drive Condition Check

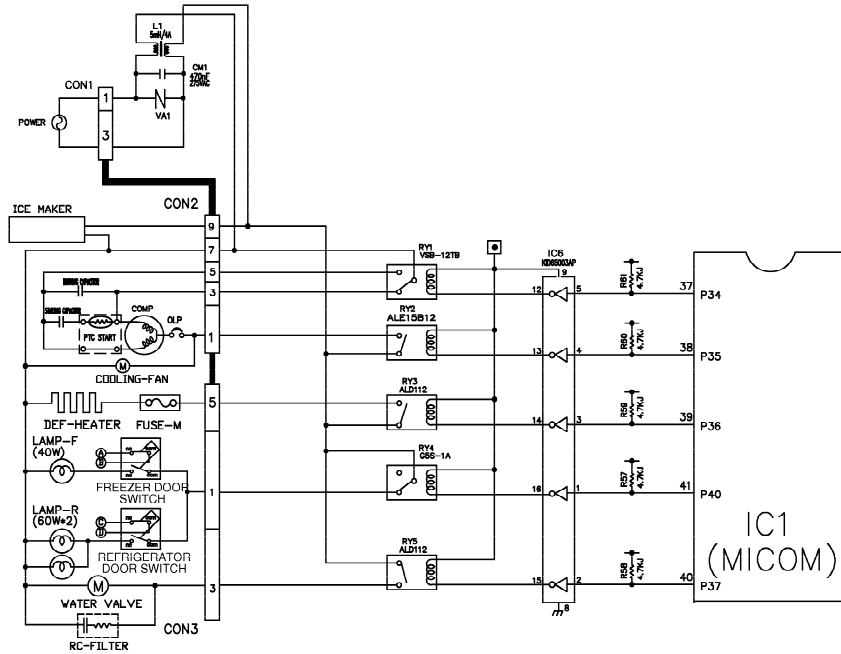

LOAD TYPE		COMP	DEFROSTING HEATER	LAMP	TCM POWER MODE (OPTIONAL)	VALVE (DISPENSER MDL)
Measurement Location (IC6)		NO.13	NO.14	NO.16	NO.12	NO.15
Condition	ON	1V or below				
	OFF	12V				

2. Fan motor driving circuit (freezing compartment fan)

1. This circuit makes standby power 0 by cutting off power supplied to ISs inside of the fan motor in the fan motor OFF.
2. This is a circuit to perform a temporary change of speed for the fan motor and applies DC voltage up to 7.5V ~ 16V to motor.
3. This circuit prevents over-driving the fan motor by cutting off power applied to the fan motor in the lock of fan motor by sensing the operation RPM of the fan motor.

	(a) part	(b) part	(c) part
MOTOR OFF	2V or less	0V	5V
MOTOR ON	13V~15V	0V	2V~3V

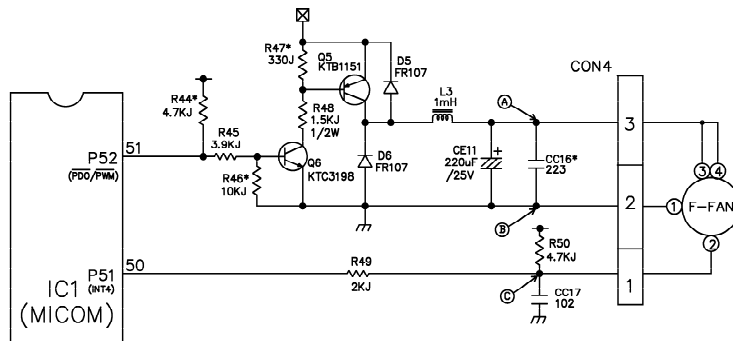

3. Buzzer Drive Condition Check

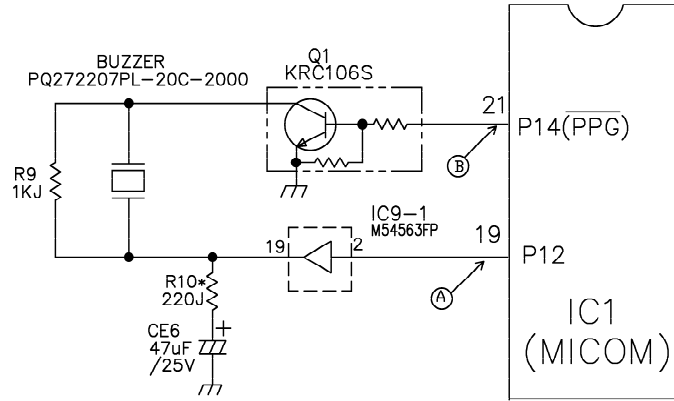

Condition Measurement Location	Tone (Ding~Dong~) when the button on the display is pushed.	Alarm for open door (beep-beep-beep)	OFF
IC1 (A)			0 V
IC1 (B)			0 V

4. Open Door Detection Circuit Check

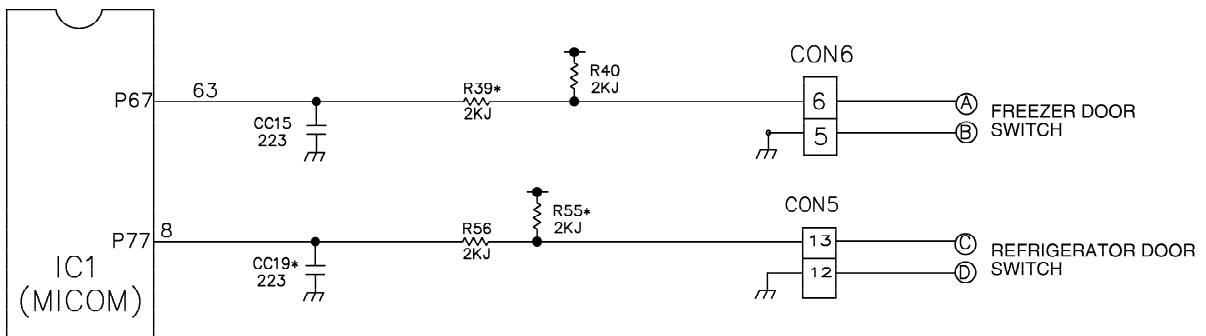

Measurement Location	(PIN NO.63 & PIN NO.8)
Freezer/ Refrigerator Door Closed	5 V
Freezer/ Refrigerator Door Open	0 V

9-2-5 Temperature Sensor Circuit

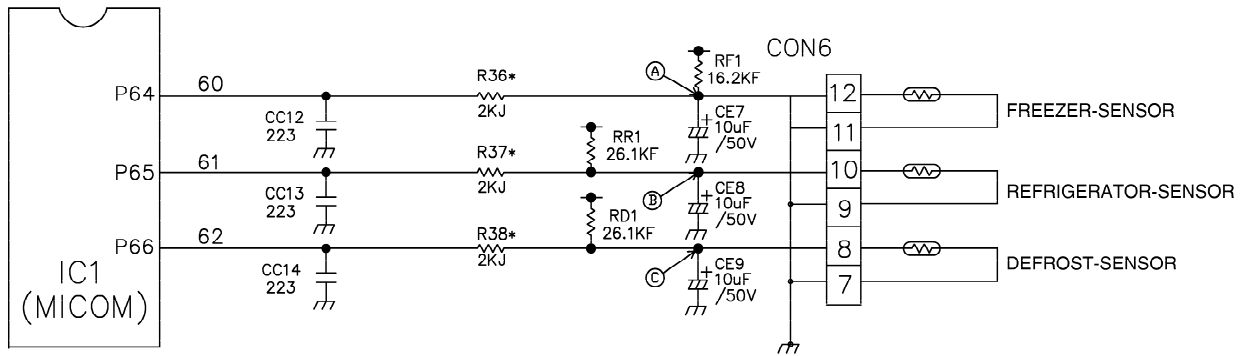

The upper CIRCUIT reads REFRIGERATOR temperature, FREEZER Temperature, and DEFROST-SENSOR temperature for defrosting and the indoor temperature for compensating for the surrounding temperature into MICOM. OPENING or SHORT state of each TEMPERATURE SENSOR are as follows:

SENSOR	CHECK POINT	NORMAL (-30°C ~ 50°C)	SHORT-CIRCUITED	OPEN
Freezer Sensor	POINT (A) Voltage	0.5 V ~ 4.5 V	0 V	5 V
Refrigerator Sensor	POINT (B) Voltage			
Defrosting Sensor	POINT (C) Voltage			

9-2-6 Refrigeration Compartment Stepping Motor Damper Circuit

* The circuit shown below is the damper circuit to regulate the refrigerator temperature.

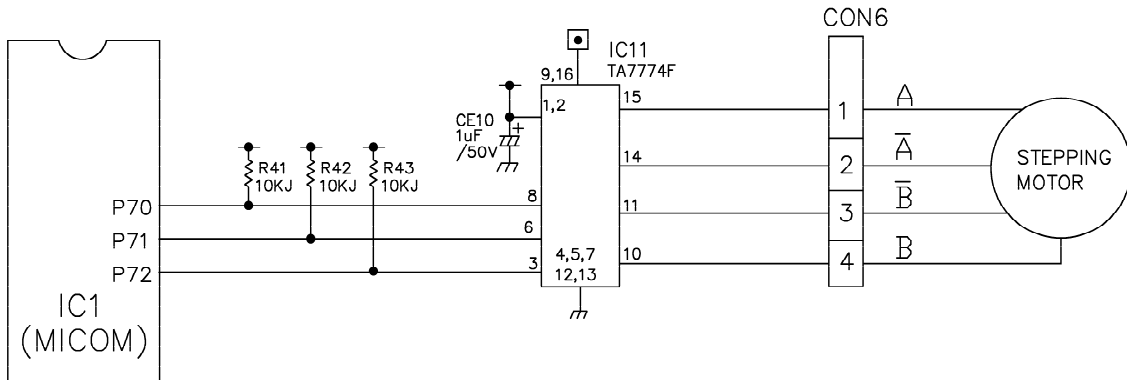

9-2-7 Dispenser Input/LED Output Circuit

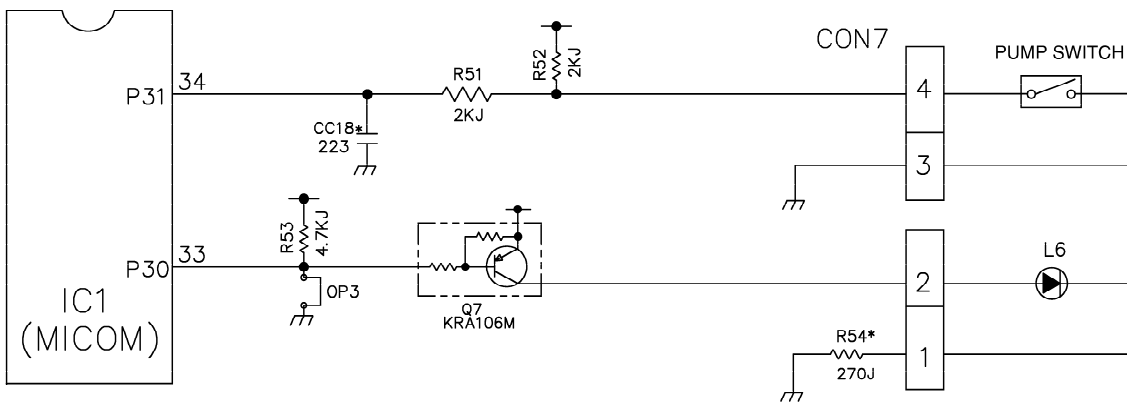

9-2-8 Temperature Compensation & Overcooling/Undercooling Compensation Circuit

1. Refrigerator Temperature Compensation

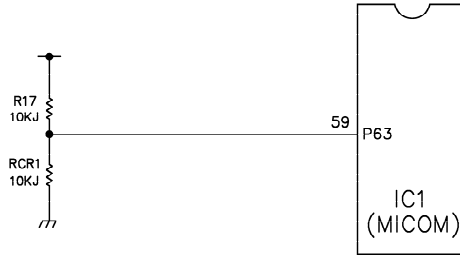

Refrigerator		Remark
Resistance (RCR)	Temperature Compensation	
180 KΩ	+2.5°C	Compensation by raising the temperature ↑
56 KΩ	+2.0°C	
33 KΩ	+1.5°C	
18 KΩ	+1.0°C	
12 KΩ	+0.5°C	
10 KΩ	0 °C	Standard Temperature
8.2 KΩ	-0.5°C	Compensation by lowering the temperature ↓
5.6 KΩ	-1.0°C	
3.3 KΩ	-1.5°C	
2 KΩ	-2.0°C	
470 Ω	-2.5°C	

▶ Table of Temperature Compensation by adjusting the resistance (difference from the current temperature) e.g., If the refrigerator compensation resistance (RCR) is changed from 10K (the current resistance) to 18K (the adjustment resistance), the temperature of the refrigerator rises 33.8°F(+1°C).

2. The temperature compensation for refrigerator compartment is in the following table:

	Revised resistance / Present resistance	470Ω	2kΩ	3.3kΩ	5.6kΩ	8.2kΩ	10kΩ	12kΩ	18kΩ	33kΩ	56kΩ	180kΩ
Refrigerator (RCR)	470Ω	No change	0.5°C Up	1°C Up	1.5°C Up	2°C Up	2.5°C Up	3°C Up	3.5°C Up	4°C Up	4.5°C Up	5°C Up
	2kΩ	0.5°C Down	No Change	0.5°C Up	1°C Up	1.5°C Up	2°C Up	2.5°C Up	3°C Up	3.5°C Up	4°C Up	4.5°C Up
	3.3kΩ	1°C Down	0.5°C Down	No Change	0.5°C Up	1°C Up	1.5°C Up	2°C Up	2.5°C Up	3°C Up	3.5°C Up	4°C Up
	5.6kΩ	1.5°C Down	1°C Down	0.5°C Down	No Change	0.5°C Up	1°C Up	1.5°C Up	2°C Up	2.5°C Up	3°C Up	3.5°C Up
	8.2kΩ	2°C Down	1.5°C Down	1°C Down	0.5°C Down	No Change	0.5°C Up	1°C Up	1.5°C Up	2°C Up	2.5°C Up	3°C Up
	10kΩ	2.5°C Down	2°C Down	1.5°C Down	1°C Down	0.5°C Down	No Change	0.5°C Up	1°C Up	1.5°C Up	2°C Up	2.5°C Up
	12kΩ	3°C Down	2.5°C Down	2°C Down	1.5°C Down	1°C Down	0.5°C Down	No Change	0.5°C Up	1°C Up	1.5°C Up	2°C Up
	18kΩ	3.5°C Down	3°C Down	2.5°C Down	2°C Down	1.5°C Down	1°C Down	0.5°C Down	No Change	0.5°C Up	1°C Up	1.5°C Up
	33kΩ	4°C Down	3.5°C Down	3°C Down	2.5°C Down	2°C Down	1.5°C Down	1°C Down	0.5°C Down	No Change	0.5°C Up	1°C Up
	56kΩ	4.5°C Down	4°C Down	3.5°C Down	3°C Down	2.5°C Down	2°C Down	1.5°C Down	1°C Down	0.5°C Down	No Change	0.5°C Up
	180kΩ	5°C Down	4.5°C Down	4°C Down	3.5°C Down	3°C Down	2.5°C Down	2°C Down	1.5°C Down	1°C Down	0.5°C Down	No Change

NOTE: This circuit is designed to input the necessary temperature compensation values into the MICOM. This adjusts the refrigerator temperature, which is different in each model.

9-2-9 Key Button Input & Display Light-On Circuit

◆ The circuit shown above determines whether a function control key on the operation display is pushed. It also turns on the corresponding function indication LED (LED Module) SEVEN SEGMENT DISPLAY (SEVEN SEGMENT DISPLAY MODULE). The drive type is the scan type

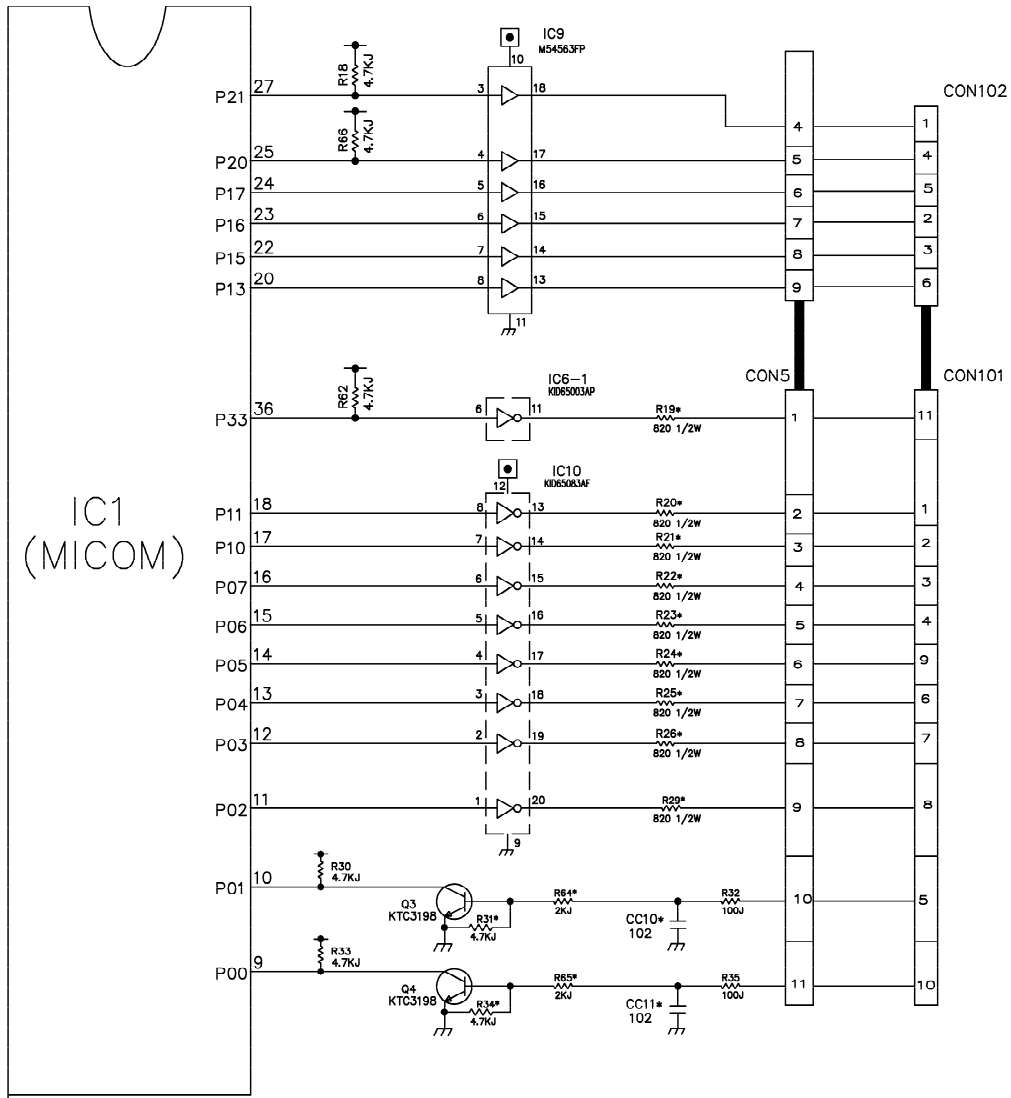

9-2-10 Power Failure Compensation Circuit (DISPENSER MODEL)

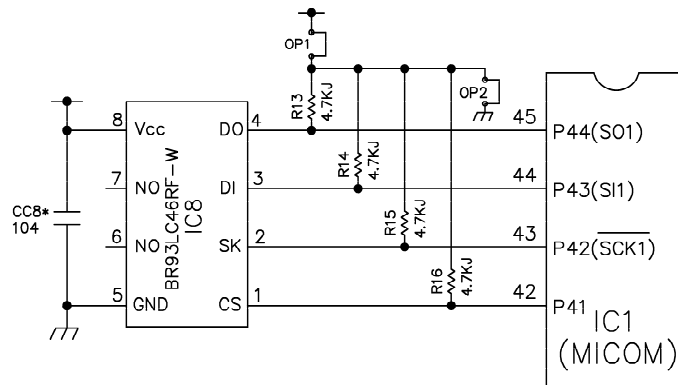

9-3 RESISTANCE SPECIFICATION OF SENSOR

TEMPERATURE DETECTED BY SENSOR	RESISTANCE OF FREEZER SENSOR	RESISTANCE OF REFRIGERATOR & DEFROST SENSOR & ROOM SENSOR
- 20 °C	22.3 KΩ	77 KΩ
- 15 °C	16.9 KΩ	60 KΩ
- 10 °C	13.0 KΩ	47.3 KΩ
- 5 °C	10.1 KΩ	38.4 KΩ
0 °C	7.8 KΩ	30 KΩ
+ 5 °C	6.2 KΩ	24.1 KΩ
+ 10 °C	4.9 KΩ	19.5 KΩ
+ 15 °C	3.9 KΩ	15.9 KΩ
+ 20 °C	3.1 KΩ	13 KΩ
+ 25 °C	2.5 KΩ	11 KΩ
+ 30 °C	2.0 KΩ	8.9 KΩ
+ 40 °C	1.4 KΩ	6.2 KΩ
+ 50 °C	0.8 KΩ	4.3 KΩ

- The resistance of the SENSOR has a $\pm 5\%$ common difference.
- Measure the resistance of the SENSOR after leaving it for over 3 minutes in the measuring temperature. This delay is necessary due to sensor response speed.

9-4 TROUBLESHOOTING

PROBLEM	INDICATED BY	CHECK	CHECKING METHOD	CAUSE	SOLUTION
POWER SOURCE is poor.	1. The whole DISPLAY LED/SEVEN SEGMENT DISPLAY is off. 2. DISPLAY LED/ SEVEN SEGMENT DISPLAY operates abnormally	1. FREEZER/ REFRIGERATOR.	Check if FREEZER/ REFRIGERATOR DOOR IS OPEN and check display.	POWER SOURCE is poor.	Check outlet Voltage.
		2. If LAMP is dim. 3. The connection of the MAIN PWB CONNECTOR.	Check visually. Check connection of CONNECTOR.	Applied voltage error. CONNECTOR connection is poor. TRANS FUSE is open.	Use boosting TRANS. Reconnect CONNECTOR. Replace TRANS.
COOLING is poor.	NO COOLING.	1. If the COMPRESSOR operate.	USE TEST MODE1 (forced COOLING). If less than 7 minutes pass after compressor shuts off, don't press the KEY and wait.	COMPRESSOR locked or blocked.	Replace COMPRESSOR.
				OLP, PTC is poor. COMPRESSOR RELAY is poor.	Replace OLP, PTC. Replace MAIN PWB.
		2. If refrigerant is leaking.	Measure the amount of frost sticking on EVAPORATOR and the surface temperature of the condenser pipe.	THE CONNECTING WIRE is poor.	Check the connection of the black wire of the MAIN PWB CONNECTOR (CON2).
				Refrigerant leakage.	Replace the leaking part and replace any lost refrigerant.
FREEZER TEMPERATURE is incorrect	1. If FAN MOTOR operates.	USE TEST MODE1 (forced COOLING).	FAN MOTOR is poor. CONNECTING WIRE is poor.	Replace the FAN MOTOR.	
				Certify the MOTOR and the connection of the black wire of the MAIN PWB CONNECTOR (CON2).	
				DEFROSTING is poor.	See DEFROSTING is poor.
				SENSOR RESISTANCE is poor.	Replace SENSOR.
4. Door Line contact.	Check the seal when the door is closed.	Door liner damaged.	Replace door liner.		

PROBLEM	INDICATED BY	CHECK	CHECKING METHOD	CAUSE	SOLUTION
COOLING is poor.	If REFRIGERATOR TEMPERATURE is too low.	1. If FREEZER TEMPERATURE is normal.	Check is FREEZER TEMPERATURE is too low.		Make sure the DOOR is attached.
		2. If amount of cool air from FAN MOTOR is sufficient.	Make sure that the amount and speed of cool air are sufficient by touching the check supplied on the REFRIGERATOR.	FAN MOTOR is poor. Passage of cool air is blocked. EVA frozen.	Replace FAN MOTOR. Remove impurities. See DEFROSTING is poor.
		3. Door Line contact.	Check door seal when door is closed.	Door liner damaged.	Replace Door liner.
DEFROSTING is poor.	NO DEFROSTING.	1. If HEATER emits heat.	USE TEST MODE2 (forced DEFROSTING).	HEATER disconnection.	Replace HEATER.
				TEMPERATURE FUSE disconnection.	Replace TEMPERATURE FUSE.
				Connection is poor.	Check EVAPORATOR connection and wire of MAIN PWB CONNECTOR.
		2. If DRAIN PIPE is blocked.	Check DRAIN PIPE.	DEFROST-SENSOR is poor. HEATER RELAY is poor. DRAIN PIPE is blocked.	Replace DEFROST-SENSOR. Replace RY3 of MAIN PWB. Remove ice and impurities. Check HEATER PLATE resistance.
		3. If ice remains after DEFROSTING.	Make sure that DEFROST SENSOR is connected. Make sure that FREEZER/ REFRIGERATOR DOOR is closed.	Connection is poor. DOOR does not close properly.	Reassemble the DEFROST-SENSOR. Reassemble DOOR. Replace GASKET.

9-5 MAIN PWB ASSEMBLY AND PARTS LIST

9-5-1 Main PWB Assembly

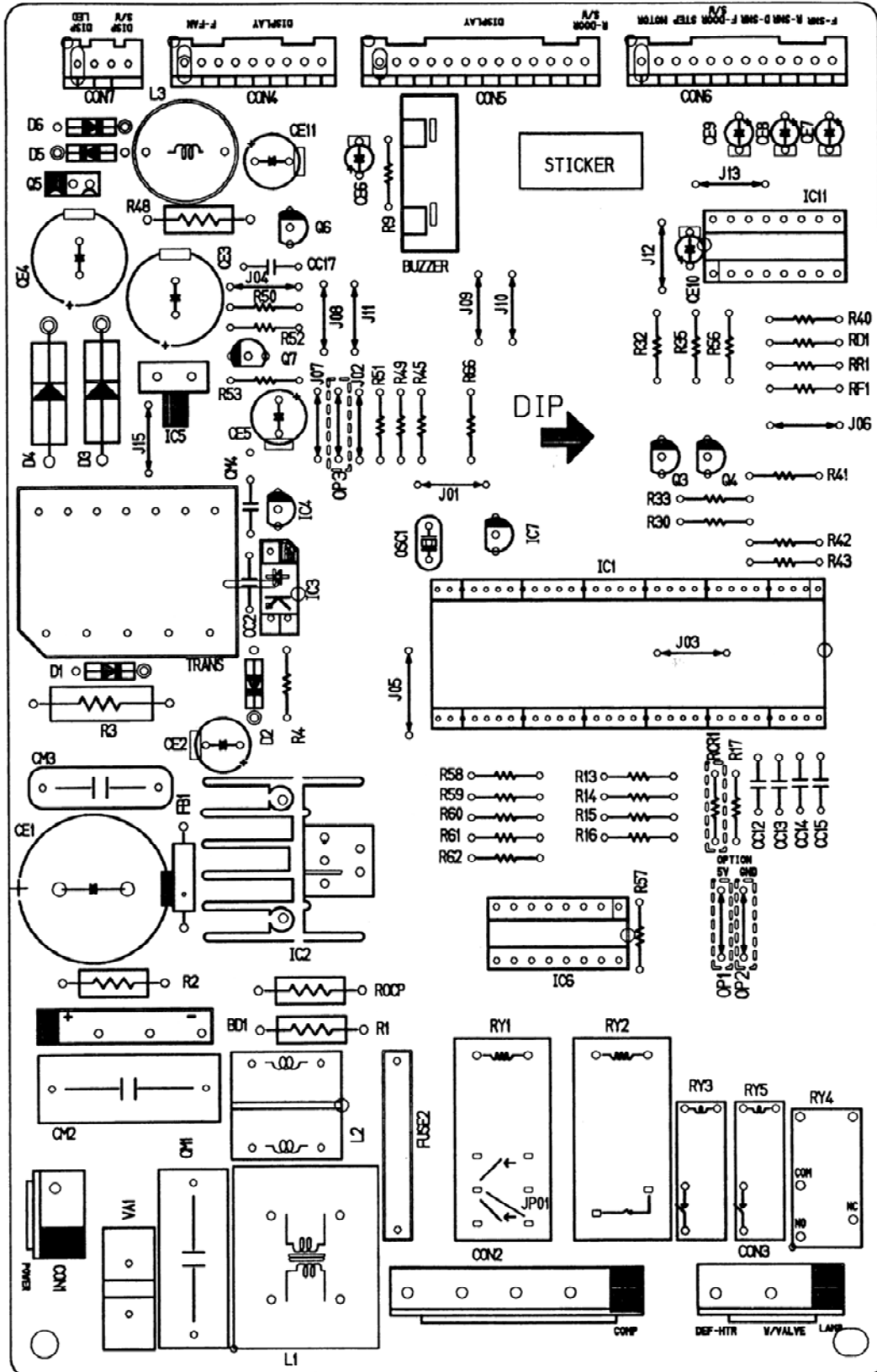

9-5-2 Replacement Parts List

No	P/NO	DESCRIPTION	SPEC	MAKER	REMARK
1	6870JB8007C	PVBP(PCB)	KS-PJT BEST	DDO SAN	T=1.6
2	6170JB2012A	TRANSFORMER,SMPSCOLL1	KS-PJT 220-240V	SAM IL	TRANS
3	6170JB2012B	TRANSFORMER,SMPSCOLL1	KS-PJT 100-127V	SAM IL	TRANS
4	6630A9106A	CONNECTOR (CIRC),WAFER	YW396-YEADN	YEON HO	CDN1
5	6630A9106D	CONNECTOR (CIRC),WAFER	YW396 YEONHO 9P 3.96MM AV	YEON HO	CDN2
6	6630A9106B	CONNECTOR (CIRC),WAFER	YW396 YEONHO 5P 3.96MM AV	YEON HO	CDN3
7	6630JB8007H	CONNECTOR (CIRC),WAFER	917787-1 AMP 9P 2.5MM STRAIGHT SN	AMP	CDN4
8	6630JB8007A	CONNECTOR (CIRC),WAFER	917791-1 AMP 13PIN 2.5MM STRAIGHT SN	AMP	CDN5
9	6630JB8007L	CONNECTOR (CIRC),WAFER	917790-1 AMP 12P 2.5MM STRAIGHT SN	AMP	CDN6
10	6630JB8007C	CONNECTOR (CIRC),WAFER	917782-1 AMP 4P 2.5MM STRAIGHT SN	AMP	CDN7
11	01SK655100A	IC,SANKEN	STR-6551 5PIN BK SMP5 2,4PIN FORM	SANKEN	IC2
12	01ZZJB2024Q	IC,DRAWING	TMP87CK40AM 64PIN,SDIP BK KS-PJT(MASK1)	TOSHIBA	IC1<=01ZZJB2024R>
13	-	-	-	-	-
14	01T0721000A	IC,TOSHIBA	TLP721F 4P BK PHOTO COUPLER	TOSHIBA	IC3
15	01KE431000A	IC,KEC	K1A431 3 PIN TP - -	KEC	IC4
16	01KE780500V	IC,KEC	K1A7805PT - -	KEC	IC5
17	01KE650030R	IC,KEC	K1D65003AF 20SDP 1 FD DRIVER	KEC	IC10
18	01KE650030R	IC,KEC	K1D65003AP 16P SDIP BK DRIVE	KEC	IC6
19	01STLM1001A	IC,STANDARD LOGIC	M54563FP 20 R/TP CONVERT	MITSUBISHI	IC9
20	01KE704200A	IC,KEC	K1A7042P 3P BK RESET -	KEC	IC7
21	01T0777400A	IC,TOSHIBA	TA7774AP 16,SDIP BK DRIVE,IC STEPPING M	TOSHIBA	IC11
22	01RH934600D	IC,RDHM	BR931 C46RF-W 8PIN SDIP BK EEPROM -	RDHM	IC8
23	692000001A	RELAY	AL1E5B12 MATSUSHITA 12V 16A 15.6V 1A	NAIS	RY2
24	6920AL2001A	RELAY	AL1E5B12 NAIS 250VAC 16A 12VDC IC NO VENTING	NAIS	RY2
25	6920JB2009A	RELAY	65S-1 DMRON 12V 3A 227V IC	DMRON	RY4
26	6920JB2007A	RELAY	V5B-1P18 TAKAMISAWA DC12V 60MA 250V 1C	FUJITSU	RY1
27	6920EC2001A	RELAY	ALD112 NAIS(THAILAND) 250V~ 3A 12V 16.6mA 1A	NAIS	RY3 RY5
28	6212JB8001B	RESONATOR,CERAMIC	CST50400NG03 MURATA 4MHZ TP	MURATA	DSC1
29	6102JB8003A	VARIATOR	INR14D271 ILJIN UL/VDE TP 270V	ILJIN	VA1
30	6102JB8001B	VARIATOR	INR14D621 ILJIN UL/VDE BK 600V	ILJIN	VA1
31	0DR107009AA	DIODE,RECTIFIERS	FR107 TP DELTA D041 1000V 1A 3	DELTA	D1,D2,D5,D6
32	0DRSA00070A	DIODE,RECTIFIERS	RL2 SANKEN BK NPN 400V PA 40A 50NSEC 10UA	SANKEN	D3,D4
33	0DR360000AA	DIODE,RECTIFIERS	D3SBA60 BK SHINDENGEN 600V 4A	SHINDENGEN	D1
34	6102V5V006A	VARIATOR	INR14D331K ILJIN UL/CSA/VDE BK	ILJIN	VA1
35	0CE4767V6F0	CAPACITOR,FIXED ELECTROLYTIC	47UF HF 450V 20% BULK SNAP TNC(105°)	RUBYCON	CE1
36	0CE4768K63B	CAPACITOR,FIXED ELECTROLYTIC	47UF KME TYPE 50V 20% FMS TP 5 (105°)	SAM VHA	CE2
37	0CE1076H63B	CAPACITOR,FIXED ELECTROLYTIC	100UF SMS,SG 25V 20% FMS TP 5	SAM VHA	CE12
38	0CE487YK63B	CAPACITOR,FIXED ELECTROLYTIC	680UF KX 25V 20% BULK SNAP TNC(105°)	SAM VHA	CE3
39	0CE687YJ61B	CAPACITOR,FIXED ELECTROLYTIC	680UF RX 35V 0.2 TP 5 FL(105°)	SAM VHA	CE4
40	0CE227BFG3B	CAPACITOR,FIXED ELECTROLYTIC	220UF KME TYPE 16V 20% FMS TP 5(105°)	SAM VHA	CE5
41	0CE227BHG3B	CAPACITOR,FIXED ELECTROLYTIC	220UF RG TYPE 25V 20% FMS TP 5(105°)	SAM VHA	CE11
42	0CE105BK63B	CAPACITOR,FIXED ELECTROLYTIC	10UF KME TYPE 50V 20% FMS TP 5(105°)	SAM VHA	CE10
43	0CE4768H63B	CAPACITOR,FIXED ELECTROLYTIC	47UF KME TYPE 25V 20% FMS TP 5(105°)	SAM VHA	CE6
44	0CE106FK63B	CAPACITOR,FIXED ELECTROLYTIC	10UF KMG 50V 20% FMS TP 5(105°)	SAM VHA	CF7~CF9
45	0CH1471K562	CAPACITOR,FIXED CERAMIC(HIGH DIELECTRIC)	470PF 50V K X7R(X) 1608 R/TP	MURATA	CC1
46	0CK2210210A	CAPACITOR,FIXED CERAMIC(HIGH DIELECTRIC)	220PF 2KV K B S	MURATA	CC2
47	0CK104K94A	CAPACITOR,FIXED CERAMIC(HIGH DIELECTRIC)	100NF 2012 50V R/TP (GRM40X7R104K50PE)	MURATA	CC3~CC7 CC8
48	0CK1020K519	CAPACITOR,FIXED CERAMIC(HIGH DIELECTRIC)	1000PF 50V K B TA52	MURATA	CC17
49	0CK2230K96A	CAPACITOR,FIXED CERAMIC(HIGH DIELECTRIC)	22NF 2012 50V 80%, 20% R/TP X7R	MURATA	CC16,CC18,CC19
50	0CK2230K949	CAPACITOR,FIXED CERAMIC(HIGH DIELECTRIC)	22NF 50V Z F TA52	MURATA	CC12~CC15
51	0CK1020K96A	CAPACITOR,FIXED CERAMIC(HIGH DIELECTRIC)	1NF 2012 50V 90%, 20% R/TP X7R	MURATA	CC10
52	0CD47418K70	CAPACITOR,FIXED FILM	0.47UF D 275V M N/PP NI R	PILKOR	CM1, CM2
53	0CF22408K70	CAPACITOR,FIXED FILM	220NF D 275V 20% BULK N/PP NI	PILKOR	CM1, CM2
54	0CD4732Y430	CAPACITOR,FIXED FILM	47000PF S 630V J M/PE NI R	SAM VHA	CM3
55	0CD22418K30	CAPACITOR,FIXED FILM	0.22UF D 100V M N/PE NI R	SAM VHA	CM4
56	0CQ2231N409	CAPACITOR,POLYESTER	0.022UF D 100V J PE TP	SAM VHA	CM5
57	0RS1503J609	RESISTOR,FIXED METAL OXIDE FILM	150K OHM 1W 5.00% TA52	SMART,CHOHYANG	R1
58	0RS202G609	RESISTOR,FIXED METAL OXIDE FILM	82K OHM 1W 5.00% TA52	SMART,CHOHYANG	R1
59	0RS301J609	RESISTOR,FIXED METAL OXIDE FILM	1L OHM 1W 5.00% TA52	SMART,CHOHYANG	R1
60	0RS3470J609	RESISTOR,FIXED METAL OXIDE FILM	0.47 OHM 1W 5% TA52	SMART,CHOHYANG	R0CP
61	0RS360K641	RESISTOR,FIXED METAL OXIDE FILM	35K OHM 2 W 5.00% TA5P	SMART,CHOHYANG	R3
62	0RJB200H672	RESISTOR,METAL GLAZED(CHIP)	820 OHM 1/2 W 5% 2012 R/TP	SMART,CHOHYANG	R19~R26,R29
63	0RD560H609	RESISTOR,FIXED CARBON FILM	560K OHM 1/2 W 5.00% TA52	SMART,CHOHYANG	R2
64	0RD150H609	RESISTOR,FIXED CARBON FILM	15K OHM 1/2 W 5.00% TA52	SMART,CHOHYANG	R48
65	0RD1000G609	RESISTOR,FIXED CARBON FILM	100 OHM 1/4 W 5.00% TA52	SMART,CHOHYANG	R32 R35
66	0RH2200L622	RESISTOR,METAL GLAZED(CHIP)	220 OHM 1/8 W 2012 5.00% D	RDHM	R10
67	0RH4701L622	RESISTOR,METAL GLAZED(CHIP)	4.7K OHM 1/8 W 2012 5.00% D	RDHM	R1F,R44,R31,R18
68	0RH1002L622	RESISTOR,METAL GLAZED(CHIP)	10K OHM 1/8 W 2012 5.00% D	RDHM	R46
69	0RJ332E672	RESISTOR,FIXED CARBON FILM	33 OHM 1/8 W 5% 2012 R/TP	RDHM	R5
70	0RD1001G609	RESISTOR,FIXED CARBON FILM	1K OHM 1/4 W 5.00% TA52	SMART,CHOHYANG	R9
71	0RH1001L622	RESISTOR,METAL GLAZED(CHIP)	1K OHM 1/8 W 2012 5.00% D	RDHM	R8
72	0RH2001L622	RESISTOR,METAL GLAZED(CHIP)	2K OHM 1/8 W 2012 5.00% D	RDHM	R55,R64, R36~R39
73	0RD2001G609	RESISTOR,FIXED CARBON FILM	2K OHM 1/4 W 5.00% TA52	SMART,CHOHYANG	R65
74	0RH3301L622	RESISTOR,METAL GLAZED(CHIP)	330 OHM 1/8 W 2012 5.00% D	RDHM	R40,R49,R51,R52,R56
75	0RH1004L622	RESISTOR,METAL GLAZED(CHIP)	10 OHM 1/8 W 2012 5.00% D	RDHM	R7
76	0RNI62G609	RESISTOR,FIXED CARBON FILM	16.2K OHM 1/4 W 1.00% TA52	SMART,CHOHYANG	RF1
77	0RN261G609	RESISTOR,FIXED CARBON FILM	26.1K OHM 1/4 W 1.00% TA52	SMART,CHOHYANG	RD1,RR1
78	0RD3901G609	RESISTOR,FIXED CARBON FILM	3.9K OHM 1/4 W 5.00% TA52	SMART,CHOHYANG	R45
79	0RD4701G609	RESISTOR,FIXED CARBON FILM	4.7K OHM 1/4 W 5.00% TA52	SMART,CHOHYANG	R4,R30,R33,R50,R57~R62,R66 R13~R16,R53
80	0RJ600E672	RESISTOR,METAL GLAZED(CHIP)	600 OHM 1/8 W 5% 2012 R/TP	RDHM	R6
81	0RD1002G609	RESISTOR,FIXED CARBON FILM	1K OHM 1/4 W 5.00% TA52	SMART,CHOHYANG	R17,RCR1,R41~R43
82	0RH1801L622	RESISTOR,METAL GLAZED(CHIP)	1.8K OHM 1/8 W 2012 5.00% D	RDHM	R7
83	0RD2702G609	RESISTOR,FIXED CARBON FILM	27K OHM 1/4 W 5.00% TA5P	SMART,CHOHYANG	R7
84	0RD4702G609	RESISTOR,FIXED CARBON FILM	47K OHM 1/4 W 5.00% TA52	SMART,CHOHYANG	-
85	0RJ910E472	RESISTOR,FIXED METAL FILM	9.1K OHM 1/8 W 1% 2012 R/TP	RDHM	RL1
86	0RJ240E472	RESISTOR,FIXED METAL FILM	2.4K OHM 1/8 W 1% 2012 R/TP	RDHM	RL2
87	0KH2700D622	RESISTOR,METAL GLAZED(CHIP)	270 OHM 1/8 W 2012 5.00% D	RDHM	RS4
88	0TRKE0008A	TRANSISTOR,BIPOLAR	KEC KT8151 BK T0126 60V 5A	KEC	GS
89	0TR319809AA	TRANSISTOR	KTC3198-TP-Y (KTC1815)KEC	KEC	GS,GS6 G4
90	0TRKE80016A	TRANSISTOR,BIPOLAR	KEC KRC106S R/TP SOT23 50V 100MA	KEC	G1
91	0TR106009AC	TRANSISTOR,BIPOLAR	KRA 106M KEC	KEC	G7
92	-	TRANSISTOR,BIPOLAR	KTC3875 KEC	KEC	-
93	6210JB8001A	FILTER(CIRC),ENC	BF33510A0 SAMWHA 5P -	SAM VHA	F81
94	6600RR10017	SWITCH,FACT	JTP1P80A6 JEIL TPV DC 50MA	JEIL	SW1
95	68S4850001A	JUMP WIRE	0.5MM 52MM TP (TAPING SNT12.5MM)	DAE A LEAD	J01~J04, J06~J13, J15, J010
96	68S4850001A	JUMP WIRE	0.5MM 52MM TP TAPING SNT12.5MM	DAE A LEAD	J05
97	68S4850001A	JUMP WIRE	0.6MM 52MM TP TAPING SNT10MM	DAE A LEAD	MP1
98	68S4850001A	JUMP WIRE	0.6MM 52MM TP TAPING SNT10MM	DAE A LEAD	MP2,MP3,R13~R16
99	6200JB8004A	FILTER(CIRC),ENC	CV940050 TNC BK	TNC	L1
100	6200JB8007X	FILTER(CIRC),ENC	UV11-05320 TNC BK 0.5A 32MH	TNC	L2
101	0LR1001M4F0	INDUCTOR,RADIAL LEAD	1000UH 20% R 6X12.5 BULK	TNC	L3
102	0FWS901B621	FUSE FAST BLOW	9000MA 250V 6.3X31.8 CY/GL KS	SAM JU	FUSE1
103	6901JB8001A	FUSE ASSSEMBLY	KMR-PJT M/S	SAM JU	FUSE HOLDER
104	0FZZJB3001A	FUSE DRAWING	2A 250V SLDV-BLOW LITTLE FUSE,TRIAD	SAM JU	FUSE1
105	6908JB3002D	BUZZER	P0272207L-20C-2000 SUNWAY PIEZO 2KHZ 80DB (CHINA)	SUNWAY	BUZZER
106	4920JB3007A	HEAT SINK	E3,3M17*25 DRIVE IC STR	-	IC22
107	1ISB0302418	SCREW TAP TITE(S),BINDING HE	+D3.0 L8.0 HSWR3/FZY	홍산	IC22
108	9VWF0120000	SOLDER(RODSIN WIRE) R50	D120	-	-
109	49111004	SOLDER,SOLDERING	H63A	HISUNG	-
110	59333105	FLUX	SG0.825-0.830 KOREA F.H-206	KDK1	-

9-5-3 PWB Assembly, Display, And Parts List

Dispenser Model

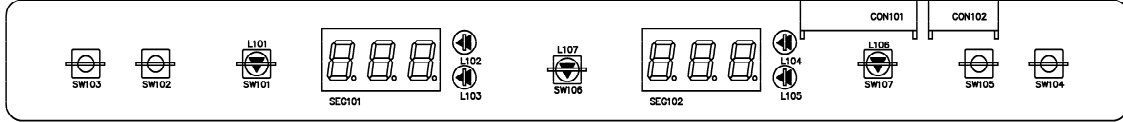

No	P/N/D	DESCRIPTION	SPEC	MAKER	REMARK
1	6870JB8090A	PWB(PCB)	KS-PJT DISPENSER DISPLAY	DDD SAN	-
2	-	-	-	-	-
3	6630JB8005D	WAFER	SMAW250-11	YEON HO	CON101
4	6630JB8004U		SMAW250-06		CON102
5	6600JB8005A	SWITCH,TACT	KPT-1105A	KYUNG IN	SW102~105
6	6600RRT002K		JTP1230A JEIL 12V DC 50MA	JEIL	
7	6600JB8004A	TACT S/W	KPT-1109R	KYUNG IN	SW101,SW107
8	-	TACT S/W	KPT-1109G	KYUNG IN	SW106
9	6327JB8001A	DISPLAY LED ASSEMBLY	LN4023-13EWRS GREEN 2.1V 1.7MCD	LEDTECH	SEG1,SEG2
10	0DLLE0059AA	LED	LT8323-41-BCN 2.1V D3 TP GREEN		L102~105
11	0DD414809AA	DIODE,SWITCHING	1N4148 26MM	PYUNG CHANG	D107~113
12	0DD400400A		1N4004	DELTA	D101~106
13	6854B50001A	JUMP WIRE	0.6MM 52MM TP TAPING SN<10MM>	-	J01~06,J08~13
14	9VWF0120000	SOLDER(ROSIN WIRE) RS0	D1.20	HEE SUNG	-
15	49111004	SOLDER,SOLDERING	H63A	-	-
16	59333105	FLUX	SGJ0.825-0.830 KOREA F.H-206	KDKI	-

Best Model

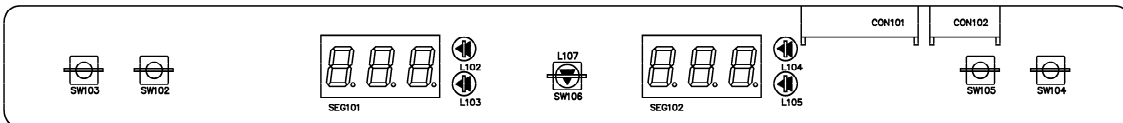

No	P/N/D	DESCRIPTION	SPEC	MAKER	REMARK
1	6870JB8090A	PWB(PCB)	KS-PJT DISPENSER DISPLAY	DDD SAN	-
2	-	-	-	-	-
3	6630JB8005D	WAFER	SMAW250-11	YEON HO	CON101
4	6630JB8004U		SMAW250-06		CON102
5	6600JB8005A	SWITCH,TACT	KPT-1105A	KYUNG IN	SW102~105
6	6600RRT002K		JTP1230A JEIL 12V DC 50MA	JEIL	
7	6600JB8004A	TACT S/W	KPT-1109R	KYUNG IN	SW106
8	-	TACT S/W	KPT-1109G	KYUNG IN	
9	6327JB8001A	DISPLAY LED ASSEMBLY	LN4023-13EWRS GREEN 2.1V 1.7MCD	LEDTECH	SEG1,SEG2
10	0DLLE0059AA	LED	LT8323-41-BCN 2.1V D3 TP GREEN		L102~105
11	0DD414809AA	DIODE,SWITCHING	1N4148 26MM	PYUNG CHANG	D107~113
12	0DD400400A		1N4004	DELTA	D101~106
13	6854B50001A	JUMP WIRE	0.6MM 52MM TP TAPING SN<10MM>	-	J01~06,J08~13
14	9VWF0120000	SOLDER(ROSIN WIRE) RS0	D1.20	HEE SUNG	-
15	49111004	SOLDER,SOLDERING	H63A	-	-
16	59333105	FLUX	SGJ0.825-0.830 KOREA F.H-206	KDKI	-

9-6 PWB DIAGRAM

9-6-1 PWB Main Assembly

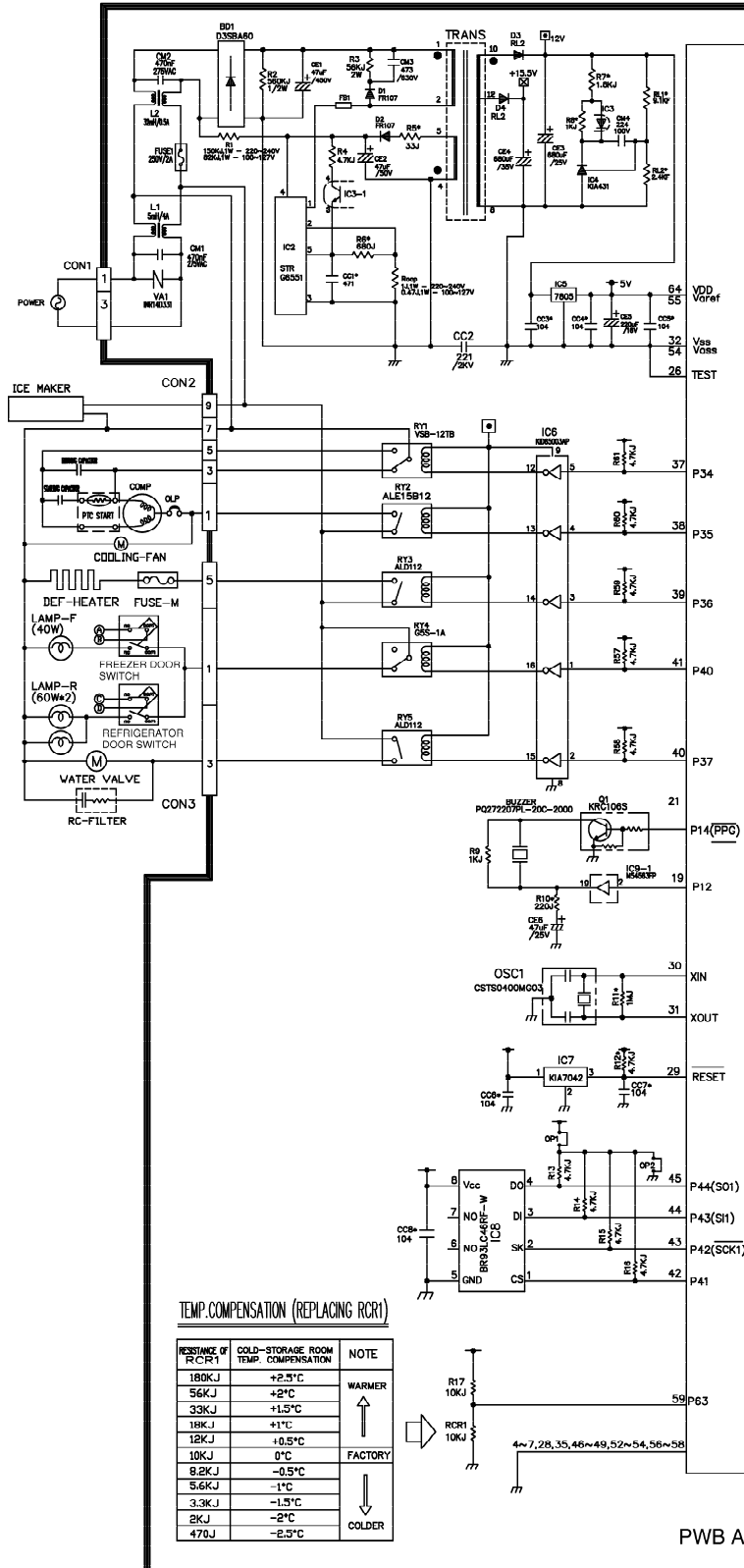

TOSHIBA TMP87C840N(IC1)

PWB ASSEMBLY

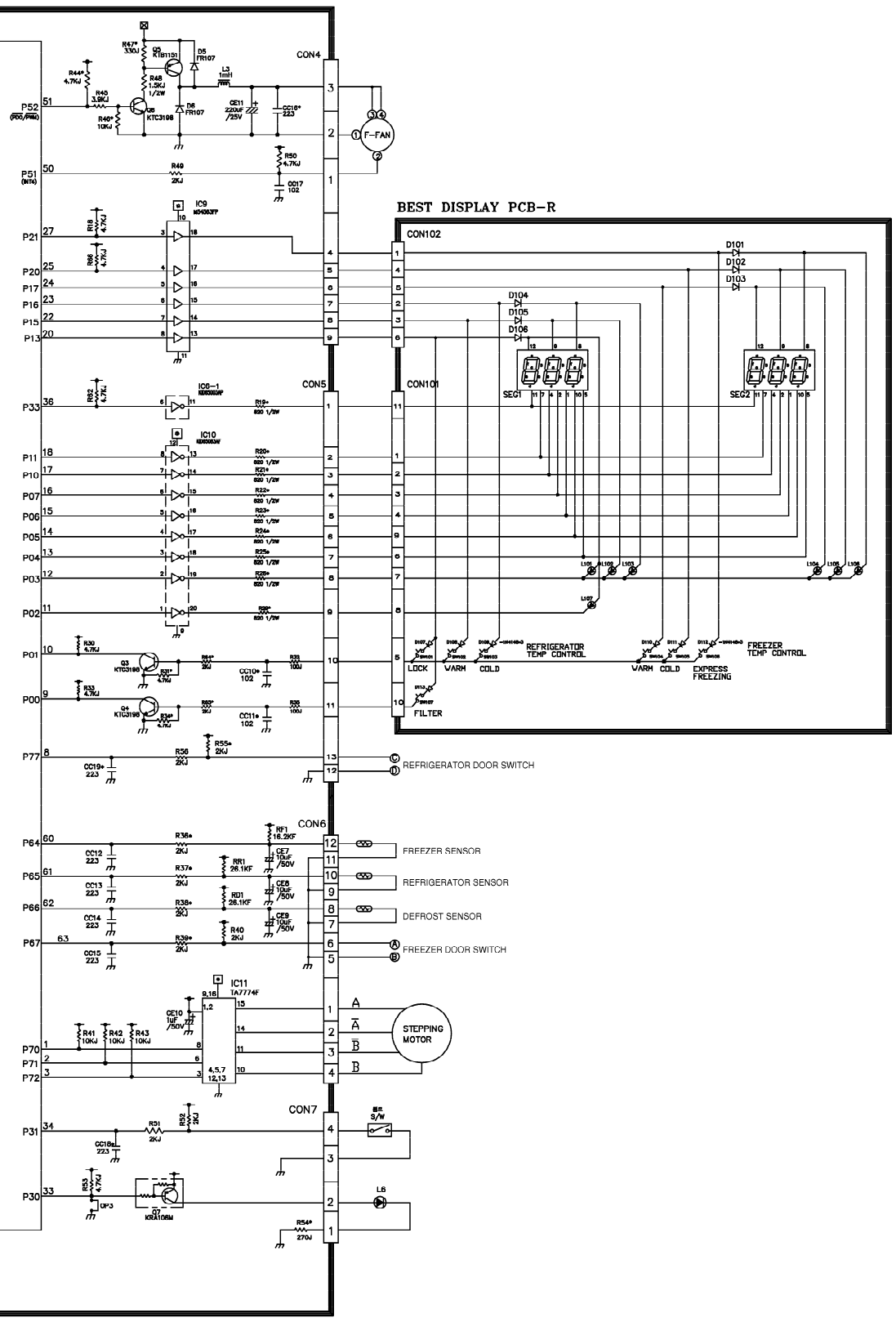

FREZZER PARTS

CAUTION: Use the part number to order part, not the position number.

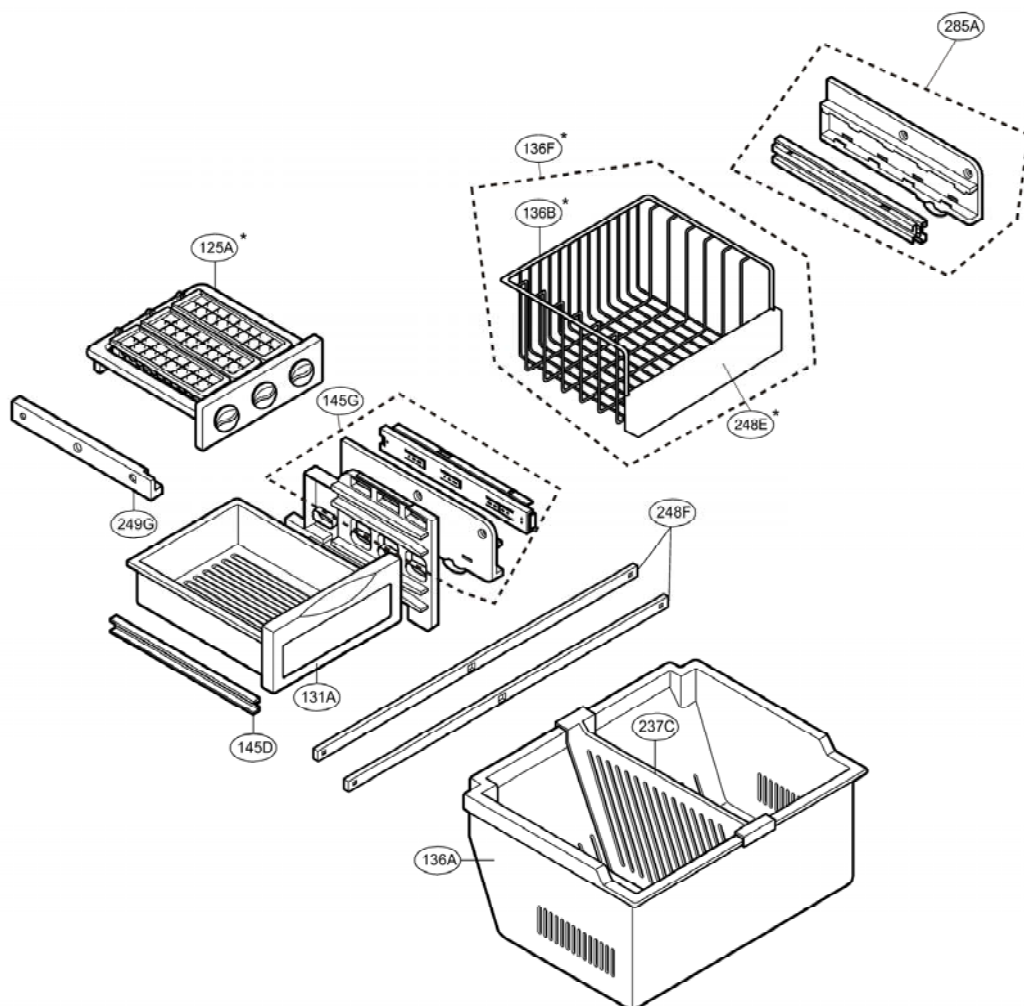

* : on some models

Ø

REFRIGERATOR PARTS

CAUTION: Use the part number to order part, not the position number.

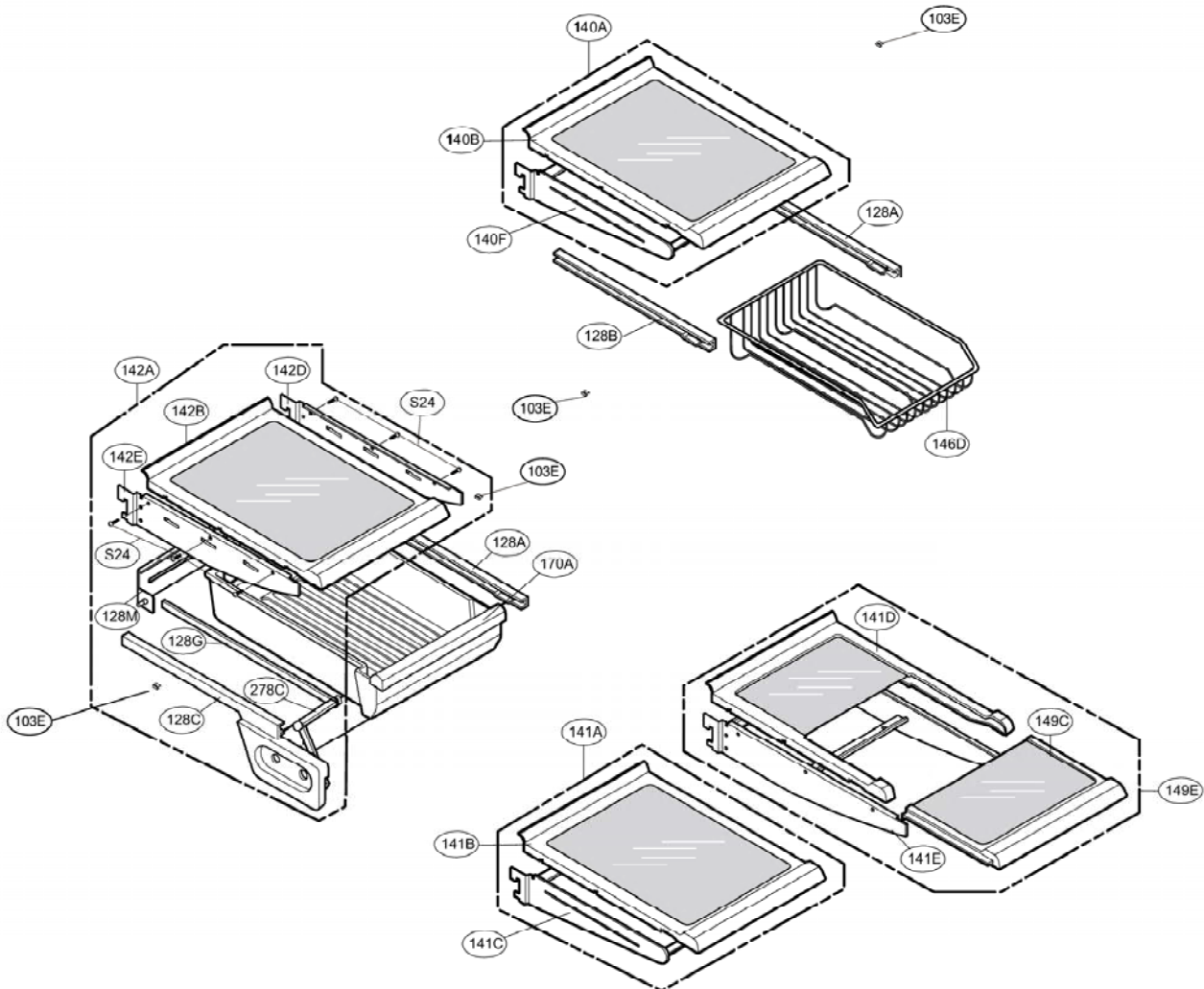

LRDC22731WW
LRDC22731ST
LRDC22731TT
LRDC22731SW
LRDC22743ST
LRDC22743TT
LRDC22743SW

REFRIGERATOR PARTS

CAUTION: Use the part number to order part, not the position number.

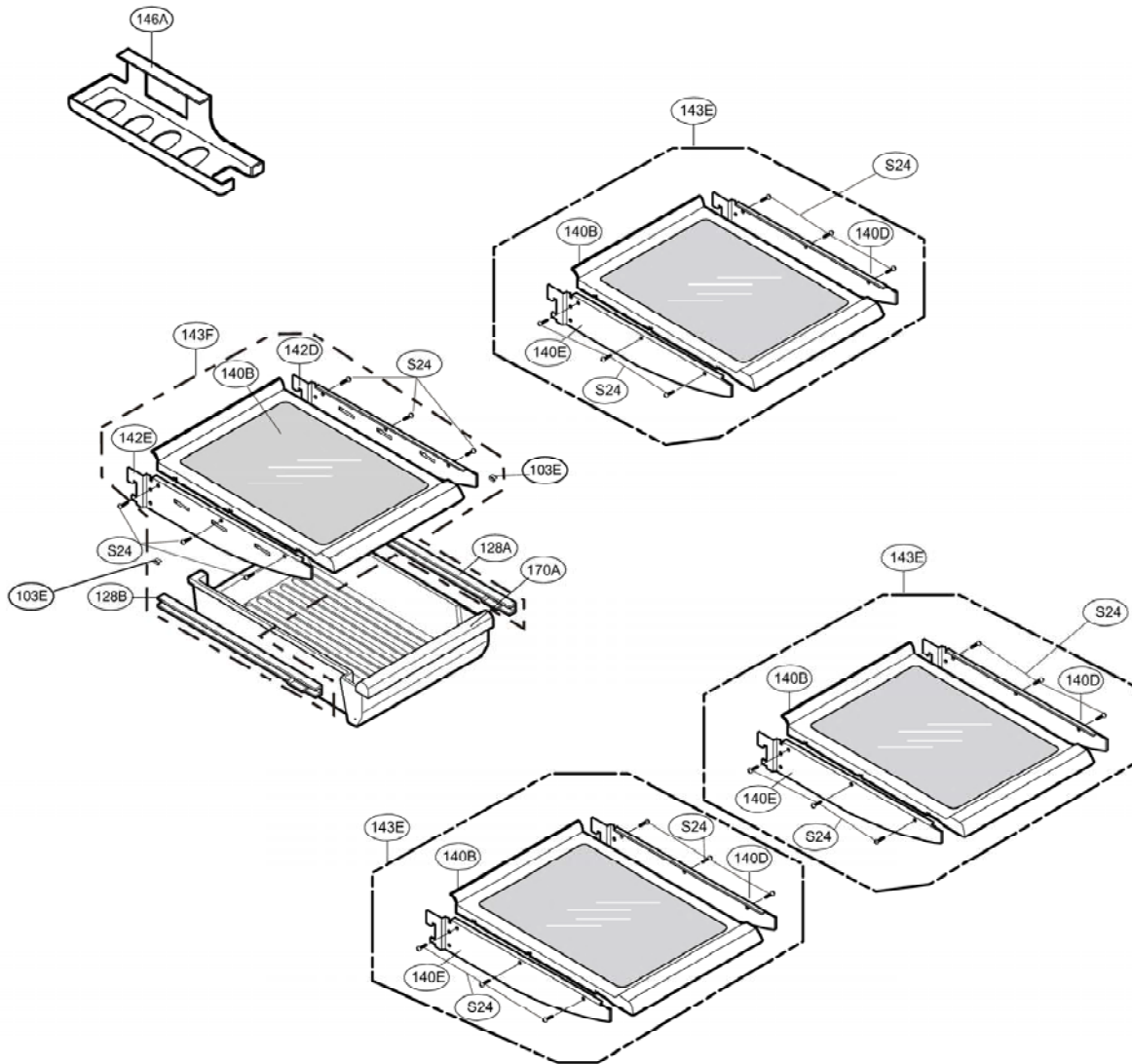

- LRDN22711TT
- LRDN22711SW
- LRDN22720BQ
- LRDN22720WW
- LRDN22720BK
- LRDN22725ST
- LRDN22725TT
- LRDN22725SW

REFRIGERATOR PARTS

CAUTION: Use the part number to order part, not the position number.

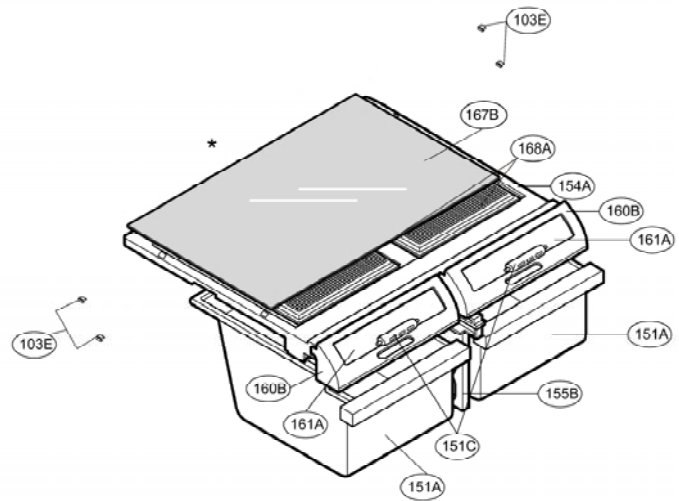
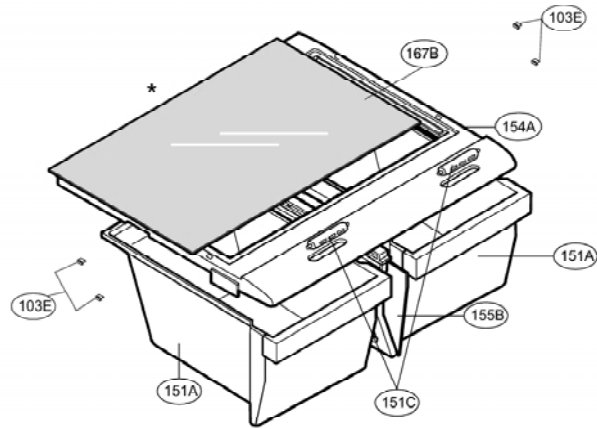
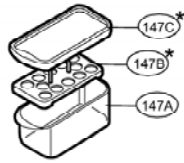

* : on some models

DOOR PARTS

CAUTION: Use the part number to order part, not the position number.

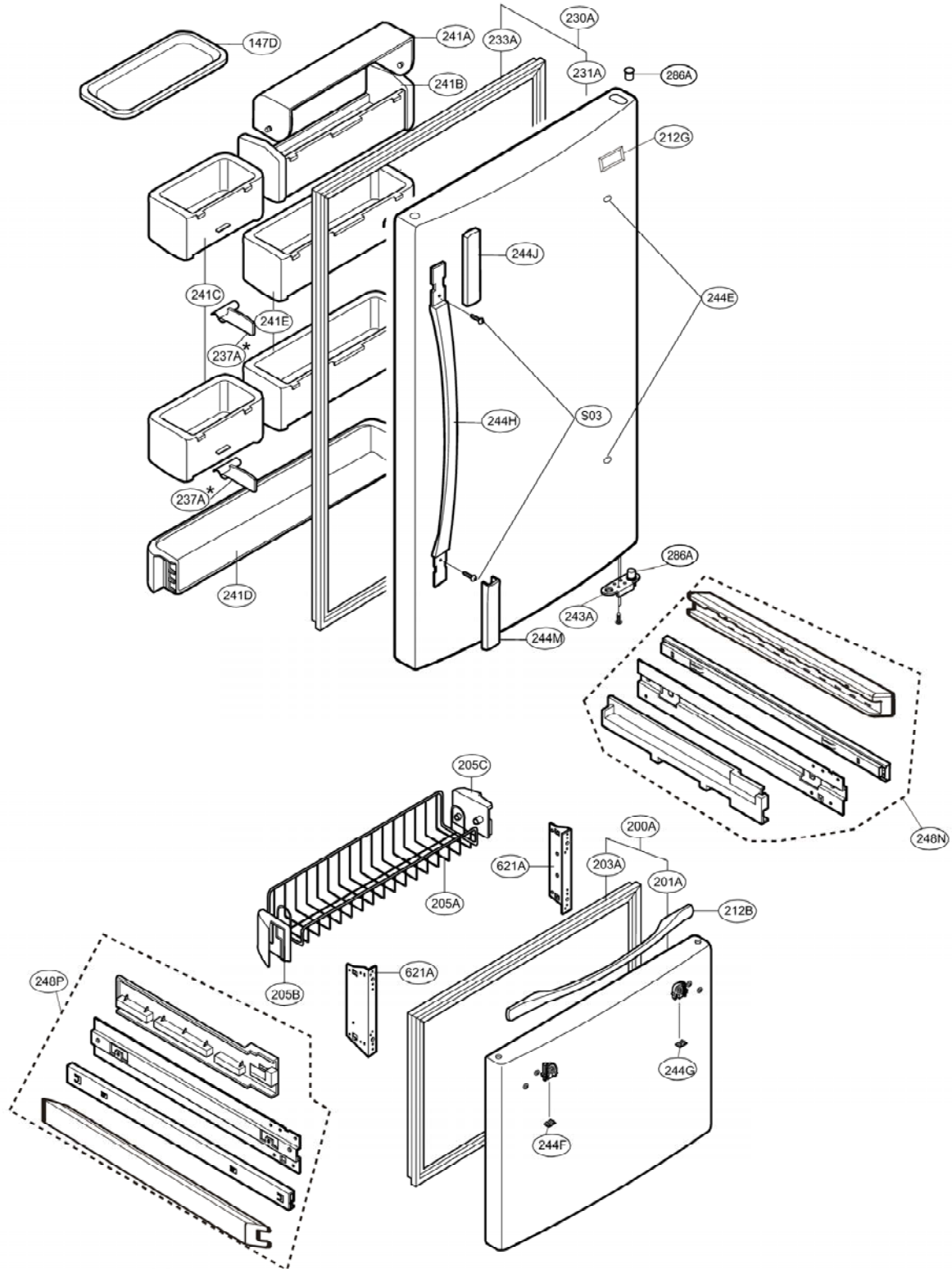

* : on some models

DOOR PARTS

CAUTION: Use the part number to order part, not the position number.

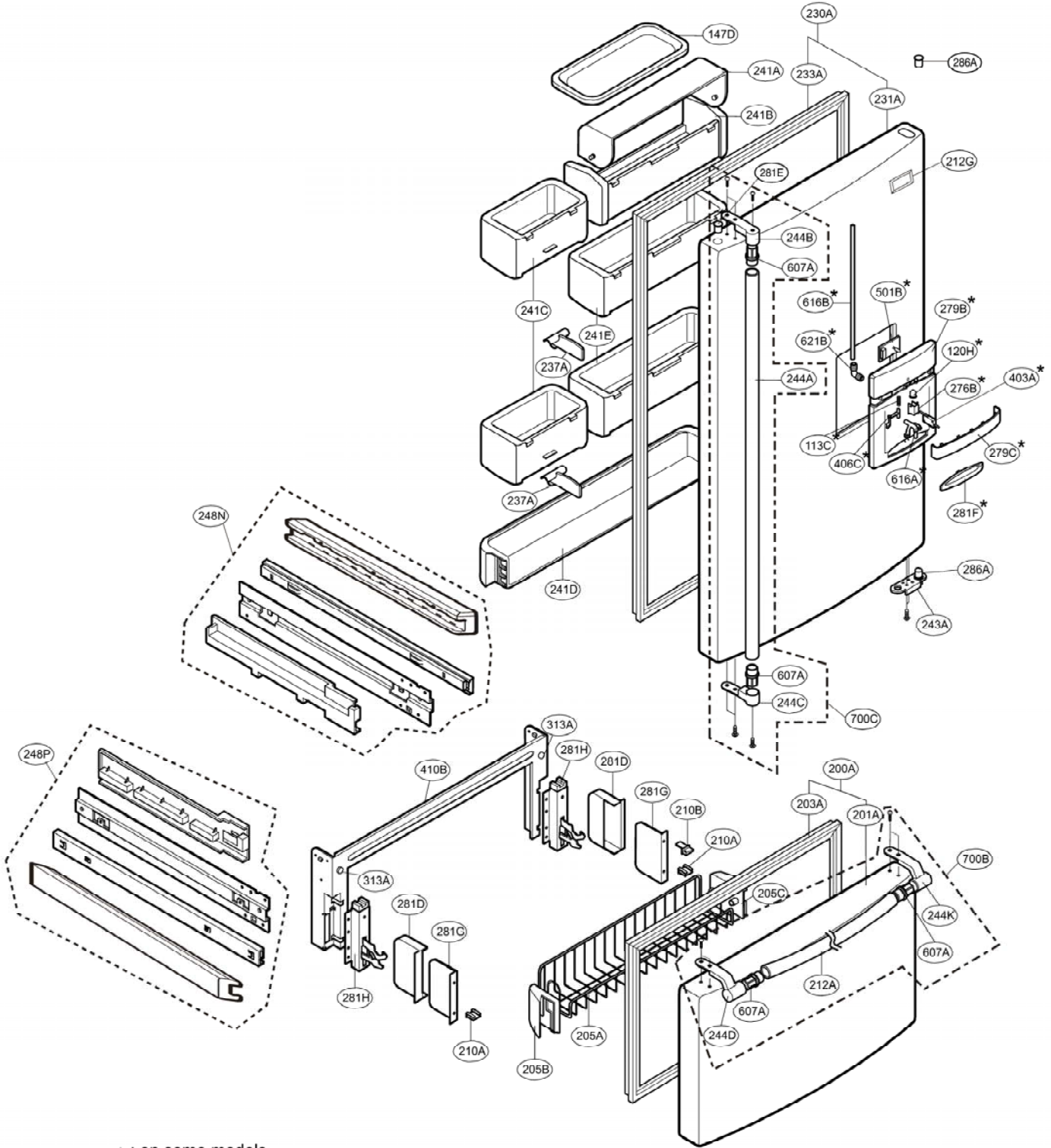

ICE MAKER PARTS

CAUTION: Use the part number to order part, not the position number.

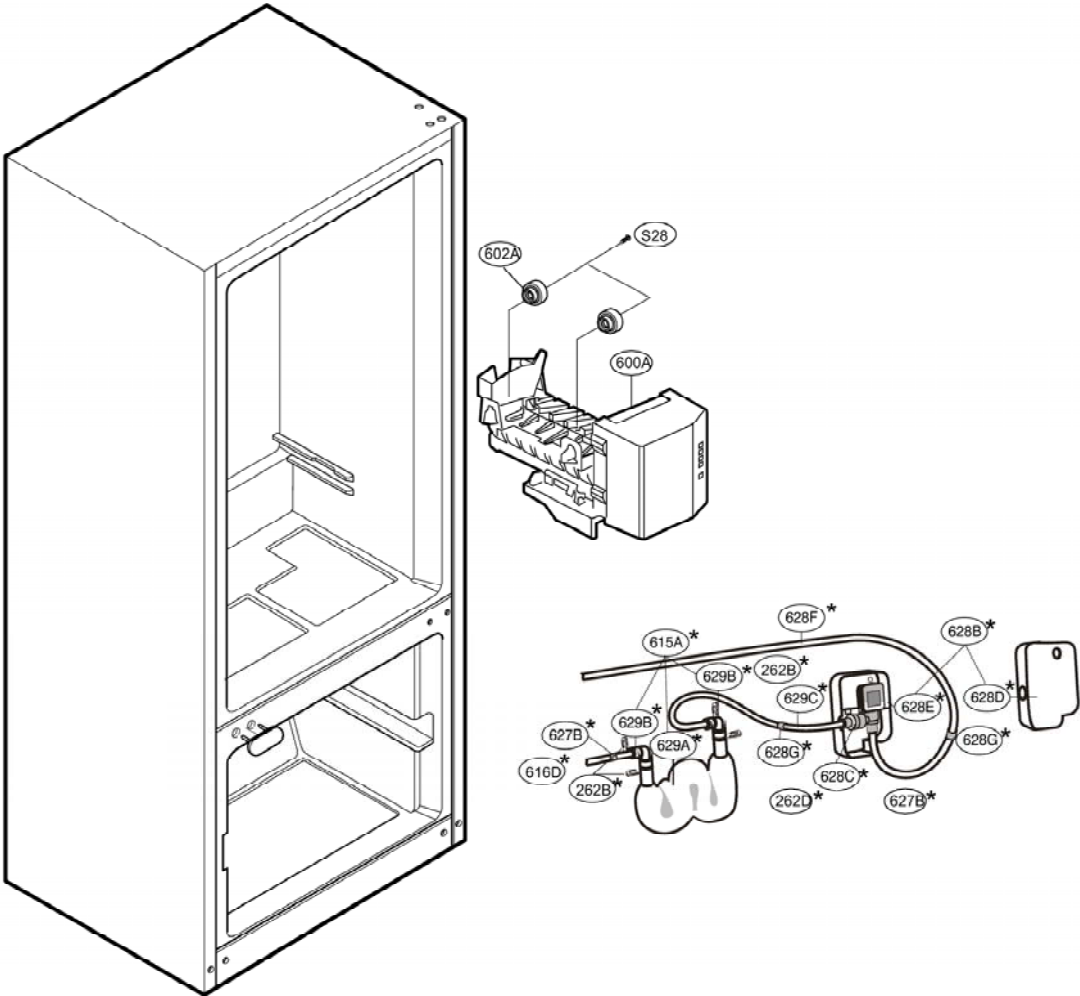

* : on some models

ICE & WATER PARTS

CAUTION: Use the part number to order part, not the position number.

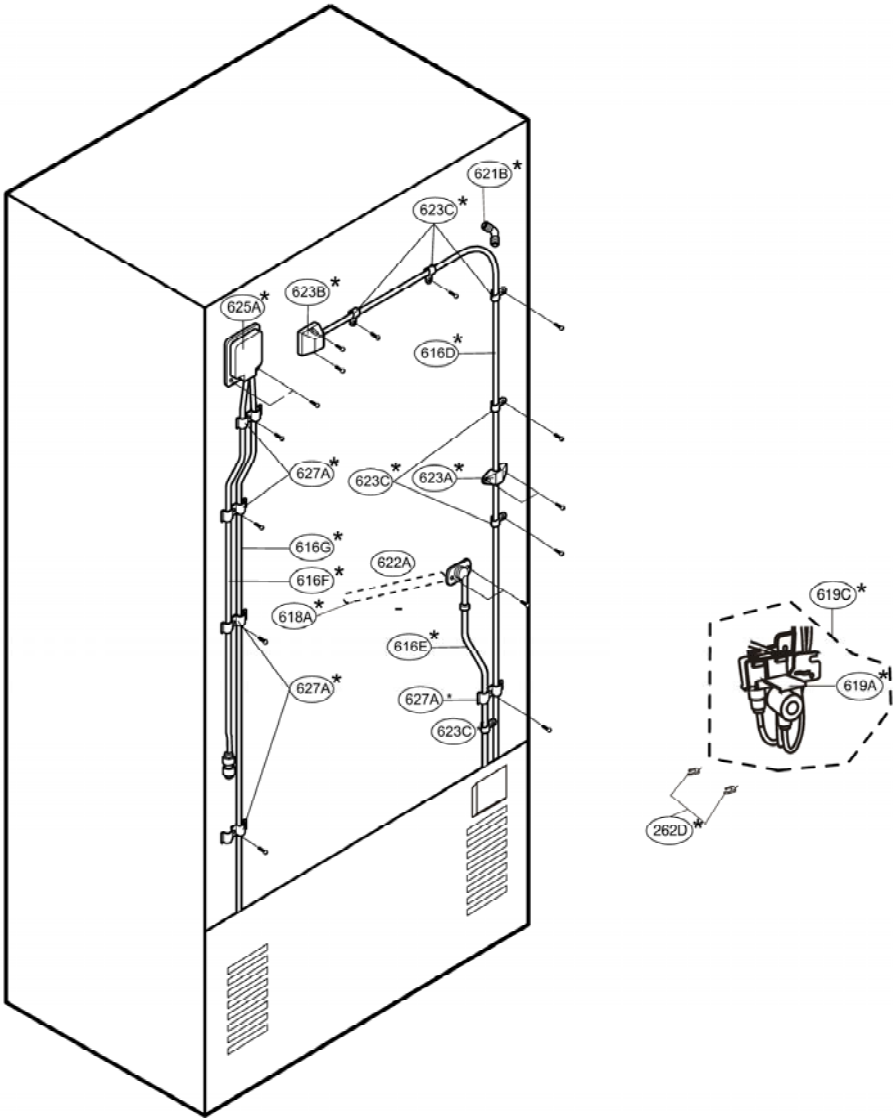

* : on some models

LOC	DESCRIPCION	NO. DE PARTE	LOC	DESCRIPCION	NO. DE PARTE
103A	HANDLE,BACK	3650JJ2003E	282E	CAP,HINGE	5006JJ2001A
103B	HANDLE,BACK	3650JJ2003A	282F	DECO,DUCT	3806JL2006E
103C	COVER ASSEMBLY,LOWER	3551JJ1015B	282H	CAP,HINGE	5006JJ3004A
103E	RAIL,SLIDE	5218JJ3001A	283B	HINGE,L	4774JJ3001A
105A	DRAIN ASSEMBLY,PIPE-Z	5251JA3003B	284D	SCREW,DRAWING	1STZJA3004K
105F	SKIRT,LOWER	5070JJ3002A	285A	GUIDE ASSEMBLY,RAIL	4975JJ2007G
106A	LEG ASSEMBLY,ADJUST	4779JJ2001A	286A	BUSH	4984JJ3003A
106B	WASHER,DRAWING	4J00382C	286A	BUSH	4984JJ3003A
113C	SPRING,W	4970JJ3004A	301A	EVAPORATOR ASSEMBLY	5421JJ1001B
120B	DUCT ASSEMBLY,MULTI	5209JJ1002A	304A	COVER ASSEMBLY,BACK-M/C	3551JJ2008B
120H	COVER,I,ED	3550JJ3003A	305B	ROLLER	4580JJ3001A
128A	GUIDE ASSEMBLY,RAIL	4975JJ2002A	305C	PIN,DRAWING	4J04238A
128A	GUIDE ASSEMBLY,RAIL	4975JJ2002A	307A	COMPRESSOR,SET ASSEMBLY	2521C-A5725
128B	GUIDE ASSEMBLY,RAIL	4975JJ2002B	308A	P.T.C ASSEMBLY	6748C-0004D
128C	GUIDE ASSEMBLY,RAIL	4975JJ2003C	309A	O.L.P	6750CRO004S
128G	LINK	4520JJ2001A	310A	COVER,P.T.C	3550JA2042A
128M	GUIDE,AIR	4974JJ2011A	312A	RUBBER,SEAT	5040JA3031A
131A	BANK ASSEMBLY,ICE	5075JJ1001B	313A	RUBBER,SEAT	5040JJ3007A
135C	COVER,GRILLE FAN	3550JJ2030A	314A	STOPPER,COMP	4620JA3009A
136A	TRAY ASSEMBLY,DRAWER	3391JJ1011B	315A	COMP BASE ASSEMBLY,STD	3103JJ1001J
136B	TRAY,DRAWER	3390JJ1087A	317A	DRIER ASSEMBLY	5851JJ2002B
136F	TRAY ASSEMBLY,DRAWER	3391JJ1033B	318A	HOLDER,DRIBER	4930JJ3002A
140A	SHELF ASSEMBLY,R	5027JJ1014D	319A	TRAY,DRIP	3390JJ0003A
140B	SHELF ASSEMBLY,R	5027JJ1005A	319C	GUIDE,FAN	4974JJ1009A
140F	SHELF ASSEMBLY,NET	5027JJ2005F	319E	BRACKET,MOTOR	4810JJ2005A
141A	SHELF ASSEMBLY,R	5027JJ1014B	323B	CONDENSER ASSEMBLY,WIRE	5403JJ1007A
141B	SHELF ASSEMBLY,R	5027JJ1005A	327A	CAP,RAIN PIPE	5006JA3034A
141C	SHELF ASSEMBLY,NET	5027JJ2005C	328A	RUBBER,DAMPING	4J03020A
141D	SHELF ASSEMBLY,R	5027JJ2011B	328B	RUBBER,DAMPING	4J04328A
141E	SHELF ASSEMBLY,NET	5027JJ2005D	329A	FAN ASSEMBLY	5901JJ1005A
142A	SHELF ASSEMBLY,R	5027JJ1013U	329C	FAN ASSEMBLY	5901JJ1004B
142B	SHELF ASSEMBLY,R	5027JJ1006A	332A	GRILLE ASSEMBLY,FAN	3531JJ1004A
142D	SHELF,NET	5026JJ2001L	401A	CONTROLLER ASSEMBLY(CIRC)	6615JB2005C
142E	SHELF,NET	5026JJ2001M	403A	SWITCH,MICRO	6600JB3001B
145A	HOLDER,SHELF	4930JJ2003A	404A	MOTOR ASSEMBLY,REF FAN	4681JK1004A
145B	HOLDER,SHELF	4930JJ2004A	405A	BRACKET ASSEMBLY,MOTOR	4811JJ2002A
145D	GUIDE,RAIL	4974JJ1012A	405C	RUBBER,MOTOR-F	5040JA2009B
145G	GUIDE ASSEMBLY,RAIL	4975JJ2005H	405F	RUBBER,MOTOR-F	5040JA2004B
146D	CAN,SERVER	5044JJ1001A	406B	SWITCH,[PUSH]	6600JB1004A
147A	BANK,DAIRY	5074JJ1005A	406C	LEVER,DISPENSER	4510JJ3001A
147B	TRAY,EGG	3390JJ1014A	409B	LAMP,[INCANDESCENT]	6912JK2002C
147C	COVER,BANK	3550JJ1017A	409D	REFLECTOR,LAMP	3034JJ1002B
147D	TRAY,BUTTER	3390JJ2003A	410A	SOCKET ASSEMBLY,LAMP	6621JK2002D
149C	SHELF ASSEMBLY,R	5027JJ2010B	410B	BRACKET ASSEMBLY,DOOR	4811JJ2004B
149E	SHELF ASSEMBLY,R	5027JJ2009B	410G	CAPACITOR,DRAWING	0CZZJB2003H
151A	TRAY ASSEMBLY,VEGETABLE	3391JJ1019E	411A	POWER CORD ASSEMBLY	6411JK1006A
151C	KNOB,SHUTTER	4940JJ2003B	418A	HEATER,SHEATH	5300JB1100J
154A	COVER,T/V	3550JJ1033A	420A	MOTOR(MECH),COOLING	4680JK1001B
155B	SUPPORTER ASSEMBLY,COVER-T/V	4981JJ2001A	501A	PWB(PCB) ASSEMBLY,MAIN	6871JB1213A
158A	COVER,LAMP	3550JJ1040A	501B	PWB(PCB) ASSEMBLY,DISPLAY	6871JB3008A
158E	COVER,LAMP	3550JJ1051A	501F	COVER,PWB	3550JJ1042B
160B	DECO,TRAY	3806JL2005D	503C	PWB(PCB) ASSEMBLY,DISPLAY	6871JB2046A
161A	COVER,TRAY	3550JJ2026A	503D	CASE,DISPLAY	3110JJ1005A
167B	GLASS,SHELF	4890JL1002K	503E	COVER,DISPLAY	3550JJ2032A
168A	COVER,MAGIC ROOM	3550JJ1035A	503G	DECO,CONTROL	3806JL1013A
170A	TRAY ASSEMBLY,MEAT	3391JJ2004K	600A	ICE MAKER ASSEMBLY,KIT	5889JA0002A
200A	DOOR ASSEMBLY,F	3581JJ8018B	602A	HOLDER,BRACKET	4930JA3037A
201A	DOOR FOAM ASSEMBLY,F	5433JJ0018D	607A	HOLDER,BRACKET	4930JJ2013A
203A	GASKET ASSEMBLY,DOOR	4987JJ1004A	610A	COVER,SENSOR	3550JJ2020A
205A	BASKET,DOOR	5004JJ1042B	611C	COVER,FILTER	3550JL1008B
205B	BASKET,TILT	5004JJ2005B	611D	COVER,FILTER	3550JJ2028A
205C	BASKET,TILT	5004JJ2005A	611E	FILTER ASSEMBLY,HEAD	5231JA2005A
210A	STOPPER,DOOR	4620JJ2005A	615A	TANK ASSEMBLY,WATER	4839JJ2003A
210B	STOPPER,DOOR	4620JJ2008A	616A	TUBE,INJECT	5210JJ2001A
212A	HANDLE,F	3650JJ1017K	616B	TUBE,PE	5210JA3005N
212G	NAME PLATE,P(H)	4140JD2001C	616D	TUBE,PE	5210JA3004M
230A	DOOR ASSEMBLY,R	3581JJ8025B	616E	TUBE,PE	5210JA3005N
231A	DOOR FOAM ASSEMBLY,R	5433JJ0033A	616F	TUBE,PE	5210JA3004B
233A	GASKET ASSEMBLY,DOOR	4987JJ1004B	616G	TUBE,PE	5210JA3005P
237A	GUIDE,BOTTLE	4974JJ2012A	618A	TUBE,INJECT	5210JJ3005B
237C	GUIDE,DRAWER	4974JJ1021A	619A	VALVE,WATER	5220JA2013A
241A	COVER,TRAY	3550JL2003H	619B	COVER,VALVE	3550JJ2024A
241B	BASKET,DOOR	5004JJ1021A	619C	VALVE ASSEMBLY,WATER	5221JA2011A
241C	BASKET ASSEMBLY,DOOR	5005JJ2017A	621B	CONNECTOR (MECH),TUBE	4932JA3009A
241D	BASKET ASSEMBLY,DOOR	5005JJ2020A	621B	CONNECTOR (MECH),TUBE	4932JA3009A
241E	BASKET ASSEMBLY,DOOR	5005JJ2018A	622A	TUBE,INLET	5210JJ3002A
243A	STOPPER,DOOR	4620JJ3006A	623A	CAP,COVER	5006JJ2004A
244A	HANDLE,R	3650JJ2008R	623B	CAP,COVER	5006JJ2003A
244B	HOLDER,HANDLE	4930JJ2009E	623C	BAND (MECH)	4770JA3001A
244C	HOLDER,HANDLE	4930JJ2010E	623C	BAND (MECH)	4770JA3001A
244D	HOLDER,HANDLE	4930JJ2012E	625A	COVER,TUBE	3550JJ2034A
244K	HOLDER,HANDLE	4930JJ2011E	627A	HOLDER,PIPE	4930JA3054A
248E	DECO,TRAY	3806JJ2035A	627B	HOLDER,BRACKET	4930JA3091A
248F	SUPPORTER,HOLDER	4980JJ2005A	628B	VALVE ASSEMBLY,WATER	5221JJ2002A
248N	RAIL ASSEMBLY,SLIDE	5219JJ2002A	628C	VALVE,WATER	5220JB2001A
248P	RAIL ASSEMBLY,SLIDE	5219JJ2002B	628D	COVER,VALVE	3550JJ2058A
262A	HOLDER,BRACKET	4930JA3093A	628E	COVER,VALVE	3550JJ2059A
262B	HOLDER,BRACKET	4930JA3093B	628F	TUBE,PE	5210JA3005B
262D	CLIP	4004JA3002A	628G	HOLDER,PIPE	4930JA3087A
276B	BUTTON,LEVER	5020JJ3001A	629A	TANK,WATER	4838JJ1003A
278C	LEVER,SHUTTER	4510JJ2002A	629B	CONNECTOR (MECH),TUBE	4932JA3009B
279B	COVER,DISPENSER	3550JL1005A	629C	TUBE,PE	5210JA3004P
279C	DECO,DISPENSER	3806JJ2021A	700B	HANDLE ASSEMBLY,F	3651JJ0002D
281A	COVER,HINGE	3550JJ1039A	700C	HANDLE ASSEMBLY,R	3651JJ1017H
281B	HINGE ASSEMBLY,U	4775JJ2005A	903A	COVER,LOWER	3550JJ0006A
281C	HINGE ASSEMBLY,L	4775JJ2008A	903B	HOLDER,COVER LOWER	4930JJ2021A
281D	COVER,HINGE	3550JJ2043A	903D	SENSOR	6500JK1003A
281E	CAP,HINGE	5006JJ3008A	903E	SENSOR	6500JK1004A
281F	DECO,RAIN	3806JJ2020A	B01	SCREW,DRAWING	1STZJA3004F
281G	COVER,HINGE	3550JJ2044A	S01	SCREW,DRAWING	1SZZJJ3010A
281H	HINGE ASSEMBLY,L	4775JJ2011A	S07	SCREW,DRAWING	4000W4A003A
282B	HINGE ASSEMBLY,C	4775JJ8002A	S22	SCREW,DRAWING	3J05696C
			S24	SCREW,DRAWING	1SZZJA3011B
			S28	SCREW,DRAWING	3J05696W
			S38	SCREW,DRAWING	4J00415D

LOC	DESCRIPCION	NO. DE PARTE	LOC	DESCRIPCION	NO. DE PARTE
103A	HANDLE,BACK	3650.JJ2003M	282H	CAP,HINGE	5006.JJ3004A
103B	HANDLE,BACK	3650.JJ2003L	283B	HINGE,L	4774.JJ3001A
103C	COVER ASSEMBLY,LOWER	3551.JJ1015F	284D	SCREW,DRAWING	1STZJA3004K
103E	RAIL,SLIDE	5218.JJ3001A	285A	GUIDE ASSEMBLY,RAIL	4975.JJ2007G
105A	DRAIN ASSEMBLY,PIPE-Z	5251.JA3003B	286A	BUSH	4984.JJ3003A
105F	SKIRT,LOWER	5070.JJ3002A	286A	BUSH	4984.JJ3003A
106A	LEG ASSEMBLY,ADJUST	4779.JJ2001A	301A	EVAPORATOR ASSEMBLY	5421.JJ1001B
106B	WASHER,DRAWING	4J00382C	304A	COVER ASSEMBLY,BACK-M/C	3551.JJ2008B
113C	SPRING,W	4970.JJ3004A	305B	ROLLER	4580.JJ3001A
120B	DUCT ASSEMBLY,MULTI	5209.JJ1002A	305C	PIN,DRAWING	4J04238A
120H	COVER,LED	3550.JJ3003A	307A	COMPRESSOR,SET ASSEMBLY	2521C-A5725
128A	GUIDE ASSEMBLY,RAIL	4975.JJ2002A	308A	P.T.C ASSEMBLY	6748C-0004D
128A	GUIDE ASSEMBLY,RAIL	4975.JJ2002A	309A	O.L.P	6750CR0004S
128B	GUIDE ASSEMBLY,RAIL	4975.JJ2002B	310A	COVER,P.T.C	3550.JA2042A
128C	GUIDE ASSEMBLY,RAIL	4975.JJ2003C	312A	RUBBER,SEAT	5040.JA3031A
128G	LINK	4520.JJ2001A	313A	RUBBER,SEAT	5040.JJ3007A
128M	GUIDE,AIR	4974.JJ2011A	314A	STOPPER,COMP	4620.JA3009A
131A	BANK ASSEMBLY,ICE	5075.JJ1001B	315A	COMP BASE ASSEMBLY,STD	3103.JJ1001J
135C	COVER,GRILLE FAN	3550.JJ2030A	317A	DRIER ASSEMBLY	5851.JJ2002B
136A	TRAY ASSEMBLY,DRAWER	3391.JJ1011B	318A	HOLDER,DRIER	4930.JJ3002A
136B	TRAY,DRAWER	3390.JJ1087A	319A	TRAY,DRIP	3390.JJ0003A
136F	TRAY ASSEMBLY,DRAWER	3391.JJ1033B	319C	GUIDE,FAN	4974.JJ1009A
140A	SHELF ASSEMBLY,R	5027.JJ1014D	319E	BRACKET,MOTOR	4810.JJ2005A
140B	SHELF ASSEMBLY,R	5027.JJ1005A	323B	CONDENSER ASSEMBLY,WIRE	5403.JJ1007A
140F	SHELF ASSEMBLY,NET	5027.JJ2005F	327A	CAP,RAIN PIPE	5006.JA3034A
141A	SHELF ASSEMBLY,R	5027.JJ1014B	328A	RUBBER,DAMPING	4J03020A
141B	SHELF ASSEMBLY,R	5027.JJ1005A	328B	RUBBER,DAMPING	4J04328A
141C	SHELF ASSEMBLY,NET	5027.JJ2005C	329A	FAN ASSEMBLY	5901.JJ1005A
141D	SHELF ASSEMBLY,R	5027.JJ2011B	329C	FAN ASSEMBLY	5901.JJ1004B
141E	SHELF ASSEMBLY,NET	5027.JJ2005D	332A	GRILLE ASSEMBLY,FAN	3531.JJ1004A
142A	SHELF ASSEMBLY,R	5027.JJ1013U	401A	CONTROLLER ASSEMBLY(CIRC)	6615JB2005C
142B	SHELF ASSEMBLY,R	5027.JJ1006A	403A	SWITCH,MICRO	6600.JB3001B
142D	SHELF,NET	5026.JJ2001L	404A	MOTOR ASSEMBLY,REF FAN	4681.JK1004A
142E	SHELF,NET	5026.JJ2001M	405A	BRACKET ASSEMBLY,MOTOR	4811.JJ2002A
145A	HOLDER,SHELF	4930.JJ2003A	405C	RUBBER,MOTOR-F	5040.JA2009B
145B	HOLDER,SHELF	4930.JJ2004A	405F	RUBBER,MOTOR-F	5040.JA2004B
145D	GUIDE,RAIL	4974.JJ1012A	406B	SWITCH,[PUSH]	6600.JB1004A
145G	GUIDE ASSEMBLY,RAIL	4975.JJ2005H	406C	LEVER,DISPENSER	4510.JJ3001A
146D	CAN,SERVER	5044.JJ1001A	409B	LAMP,[INCANDESCENT]	6912.JK2002C
147A	BANK,DAIRY	5074.JJ1005A	409D	REFLECTOR,LAMP	3034.JJ1002B
147B	TRAY,EGG	3390.JJ1014A	410A	SOCKET ASSEMBLY,LAMP	6621.JK2002D
147C	COVER,BANK	3550.JJ1017A	410B	BRACKET ASSEMBLY,DOOR	4811.JJ2004B
147D	TRAY,BUTTER	3390.JJ2003A	410G	CAPACITOR,DRAWING	0CZZJB2003H
149C	SHELF ASSEMBLY,R	5027.JJ2010B	411A	POWER CORD ASSEMBLY	6411.JK1006A
149E	SHELF ASSEMBLY,R	5027.JJ2009B	418A	HEATER,SHEATH	5300.JB1100J
151A	TRAY ASSEMBLY,VEGETABLE	3391.JJ1019E	420A	MOTOR(MECH),COOLING	4680.JK1001B
151C	KNOB,SHUTTER	4940.JJ2003B	501A	PWB(PCB) ASSEMBLY,MAIN	6871.JB1213A
154A	COVER,T/V	3550.JJ1033A	501B	PWB(PCB) ASSEMBLY,DISPLAY	6871.JB3008A
155B	SUPPORTER ASSEMBLY,COVER-T/V	4981.JJ2001A	501F	COVER,PWB	3550.JJ1042B
158A	COVER,LAMP	3550.JJ1040A	503C	PWB(PCB) ASSEMBLY,DISPLAY	6871.JB2046A
158E	COVER,LAMP	3550.JJ1051A	503D	CASE,DISPLAY	3110.JJ1005A
160B	DECO,TRAY	3806.JL2005D	503E	COVER,DISPLAY	3550.JJ2032A
161A	COVER,TRAY	3550.JJ2026A	503G	DECO,CONTROL	3806.JL1013A
167B	GLASS,SHELF	4890.JL1002K	600A	ICE MAKER ASSEMBLY,KIT	5989.JA0002A
168A	COVER,MAGIC ROOM	3550.JJ1035A	602A	HOLDER,BRACKET	4930.JA3037A
170A	TRAY ASSEMBLY,MEAT	3391.JJ2004K	607A	HOLDER,BRACKET	4930.JJ2013A
200A	DOOR ASSEMBLY,F	3581.JJ8018C	610A	COVER,SENSOR	3550.JJ2020A
201A	DOOR FOAM ASSEMBLY,F	5433.JJ0018J	611C	COVER,FILTER	3550.JL1008B
203A	GASKET ASSEMBLY,DOOR	4987.JJ1004E	611D	COVER,FILTER	3550.JJ2028A
205A	BASKET,DOOR	5004.JJ1042B	611E	FILTER ASSEMBLY,HEAD	5231.JA2005A
205B	BASKET,TILT	5004.JJ2005B	615A	TANK ASSEMBLY,WATER	4839.JJ2003A
205C	BASKET,TILT	5004.JJ2005A	616A	TUBE,INJECT	5210.JJ2001A
210A	STOPPER,DOOR	4620.JJ2005A	616B	TUBE,PE	5210.JA3005N
210B	STOPPER,DOOR	4620.JJ2008A	616D	TUBE,PE	5210.JA3004M
212A	HANDLE,F	3650.JJ1017H	616E	TUBE,PE	5210.JA3005N
212G	NAME PLATE,P(H)	4140.JD2001C	616F	TUBE,PE	5210.JA3004B
230A	DOOR ASSEMBLY,R	3581.JJ8025C	616G	TUBE,PE	5210.JA3005P
231A	DOOR FOAM ASSEMBLY,R	5433.JJ0033C	618A	TUBE,INJECT	5210.JJ3005B
233A	GASKET ASSEMBLY,DOOR	4987.JJ1004F	619A	VALVE,WATER	5220.JA2013A
237A	GUIDE,BOTTLE	4974.JJ2012A	619B	COVER,VALVE	3550.JJ2024A
237C	GUIDE,DRAWER	4974.JJ1021A	619C	VALVE ASSEMBLY,WATER	5221.JA2011A
241A	COVER,TRAY	3550.JL2003H	621B	CONNECTOR (MECH),TUBE	4932.JA3009A
241B	BASKET,DOOR	5004.JJ1021A	622A	TUBE,INLET	5210.JJ3002A
241C	BASKET ASSEMBLY,DOOR	5005.JJ2017A	623A	CAP,COVER	5006.JJ2004A
241D	BASKET ASSEMBLY,DOOR	5005.JJ2020A	623B	CAP,COVER	5006.JJ2003A
241E	BASKET ASSEMBLY,DOOR	5005.JJ2018A	623C	BAND (MECH)	4770.JA3001A
243A	STOPPER,DOOR	4620.JJ3006C	625A	COVER,TUBE	3550.JJ2034A
244A	HANDLE,R	3650.JJ2008E	627A	HOLDER,PIPE	4930.JA3054A
244B	HOLDER,HANDLE	4930.JJ2009A	627B	HOLDER,BRACKET	4930.JA3091A
244C	HOLDER,HANDLE	4930.JJ2010A	628B	VALVE ASSEMBLY,WATER	5221.JJ2002A
244D	HOLDER,HANDLE	4930.JJ2012A	628C	VALVE,WATER	5220.JB2001A
244K	HOLDER,HANDLE	4930.JJ2011A	628D	COVER,VALVE	3550.JJ2058A
248E	DECO,TRAY	3806.JJ2035A	628E	COVER,VALVE	3550.JJ2059A
248F	SUPPORTER,HOLDER	4980.JJ2005A	628F	TUBE,PE	5210.JA3005B
248N	RAIL ASSEMBLY,SLIDE	5219.JJ2002A	628G	HOLDER,PIPE	4930.JA3087A
248P	RAIL ASSEMBLY,SLIDE	5219.JJ2002B	629A	TANK,WATER	4838.JJ1003A
262A	HOLDER,BRACKET	4930.JA3093A	629B	CONNECTOR (MECH),TUBE	4932.JA3009B
262B	HOLDER,BRACKET	4930.JA3093B	629C	TUBE,PE	5210.JA3004P
262D	CLIP	4004.JA3002A	700B	HANDLE ASSEMBLY,F	3651.JJ0002B
276B	BUTTON,LEVER	5020.JJ3001C	700C	HANDLE ASSEMBLY,R	3651.JJ1017F
278C	LEVER,SHUTTER	4510.JJ2002A	903A	COVER,LOWER	3550.JJ0006C
279B	COVER,DISPENSER	3550.JL1005D	903B	HOLDER,COVER LOWER	4930.JJ2021A
279C	DECO,DISPENSER	3806.JJ2021D	903D	SENSOR	6500.JK1003A
281A	COVER,HINGE	3550.JJ1039C	903E	SENSOR	6500.JK1004A
281B	HINGE ASSEMBLY,U	4775.JJ2005A	B01	SCREW,DRAWING	1STZJA3004F
281C	HINGE ASSEMBLY,L	4775.JJ2008A	S01	SCREW,DRAWING	1SZJJ3010A
281D	COVER,HINGE	3550.JJ2043A	S07	SCREW,DRAWING	4000W4A003A
281E	CAP,HINGE	5006.JJ3008C	S22	SCREW,DRAWING	3J05696C
281F	DECO,DRAIN	3806.JJ2020D	S24	SCREW,DRAWING	1SZJA3011B
281G	COVER,HINGE	3550.JJ2044A	S28	SCREW,DRAWING	3J05696W
281H	HINGE ASSEMBLY,L	4775.JJ2011A	S38	SCREW,DRAWING	4J00415D
282B	HINGE ASSEMBLY,C	4775.JJ8002C			
282E	CAP,HINGE	5006.JJ2001F			
282F	DECO,DUCT	3806.JL2006E			

LOC	DESCRIPCION	NO. DE PARTE	LOC	DESCRIPCION	NO. DE PARTE
103A	HANDLE, BACK	3650JJ2003M	282F	DECO, DUCT	3806JL2006E
103B	HANDLE, BACK	3650JJ2003L	282H	CAP, HINGE	5006JJ3004A
103C	COVER ASSEMBLY, LOWER	3551JJ1015F	283B	HINGE, L	4774JJ3001A
103E	RAIL, SLIDE	5218JJ3001A	284D	SCREW, DRAWING	1STZJA3004K
105A	DRAIN ASSEMBLY, PIPE-Z	5251JA3003B	285A	GUIDE ASSEMBLY, RAIL	4975JJ2007G
105F	SKIRT, LOWER	5070JJ3002A	286A	BUSH	4984JJ3003A
106A	LEG ASSEMBLY, ADJUST	4779JJ2001A	301A	EVAPORATOR ASSEMBLY	5421JJ1001B
106B	WASHER, DRAWING	4J00382C	304A	COVER ASSEMBLY, BACK-M/C	3551JJ2008B
113C	SPRING, W	4970JJ3004A	305B	ROLLER	4580JJ3001A
120B	DUCT ASSEMBLY, MULTI	5209JJ1002A	305B	ROLLER	4580JJ3001A
120H	COVER, LED	3550JJ3003A	305C	PIN, DRAWING	4J04238A
128A	GUIDE ASSEMBLY, RAIL	4975JJ2002A	307A	COMPRESSOR, SET ASSEMBLY	2521C-A5725
128A	GUIDE ASSEMBLY, RAIL	4975JJ2002A	308A	P.T.C ASSEMBLY	6748C-0004D
128B	GUIDE ASSEMBLY, RAIL	4975JJ2002B	309A	O.L.P	6750CR0004S
128C	GUIDE ASSEMBLY, RAIL	4975JJ2003C	310A	COVER, P.T.C	3550JA2042A
128G	LINK	4520JJ2001A	312A	RUBBER, SEAT	5040JA30031A
128M	GUIDE, AIR	4974JJ2011A	313A	RUBBER, SEAT	5040JJ3007A
131A	BANK ASSEMBLY, ICE	5075JJ1001B	314A	STOPPER, COMP	4620JA3009A
135C	COVER, GRILLE FAN	3550JJ2030A	315A	COMP BASE ASSEMBLY, STD	3103JJ1001J
136A	TRAY ASSEMBLY, DRAWER	3391JJ1011B	317A	DRIER ASSEMBLY	5851JJ2002B
136B	TRAY, DRAWER	3390JJ1087A	318A	HOLDER, DRIER	4930JJ3002A
136F	TRAY ASSEMBLY, DRAWER	3391JJ1033B	319A	TRAY, DRIP	3390JJ0003A
140A	SHELF ASSEMBLY, R	5027JJ1014D	319C	GUIDE, FAN	4974JJ1009A
140B	SHELF ASSEMBLY, R	5027JJ1005A	319E	BRACKET, MOTOR	4810JJ2005A
140F	SHELF ASSEMBLY, NET	5027JJ2005F	323B	CONDENSER ASSEMBLY, WIRE	5403JJ1007A
141A	SHELF ASSEMBLY, R	5027JJ1014B	327A	CAP, DRAIN PIPE	5006JA3034A
141B	SHELF ASSEMBLY, R	5027JJ1005A	328A	RUBBER, DAMPING	4J03020A
141C	SHELF ASSEMBLY, NET	5027JJ2005C	328B	RUBBER, DAMPING	4J04328A
141D	SHELF ASSEMBLY, R	5027JJ2011B	329A	FAN ASSEMBLY	5901JJ1005A
141E	SHELF ASSEMBLY, NET	5027JJ2005D	329C	FAN ASSEMBLY	5901JJ1004B
142A	SHELF ASSEMBLY, R	5027JJ1013U	332A	GRILLE ASSEMBLY, FAN	3531JJ1004A
142B	SHELF ASSEMBLY, R	5027JJ1006A	401A	CONTROLLER ASSEMBLY(CIRC)	6615JB2005C
142D	SHELF, NET	5026JJ2001L	403A	SWITCH, MICRO	6600JB3001B
142E	SHELF, NET	5026JJ2001M	404A	MOTOR ASSEMBLY, REF FAN	4681JK1004A
145A	HOLDER, SHELF	4930JJ2003A	405A	BRACKET ASSEMBLY, MOTOR	4811JJ2002A
145B	HOLDER, SHELF	4930JJ2004A	405C	RUBBER, MOTOR-F	5040JA2009B
145D	GUIDE, RAIL	4974JJ1012A	405F	RUBBER, MOTOR-F	5040JA2004B
145G	GUIDE ASSEMBLY, RAIL	4975JJ2005H	406B	SWITCH, [PUSH]	6600JB1004A
146D	CAN, SERVER	5044JJ1001A	406C	LEVER, DISPENSER	4510JJ3001A
147A	BANK, DAIRY	5074JJ1005A	409B	LAMP, [INCANDESCENT]	6912JK2002C
147B	TRAY, EGG	3390JJ1014A	409D	REFLECTOR, LAMP	3034JJ1002B
147C	COVER, BANK	3550JJ1017A	410A	SOCKET ASSEMBLY, LAMP	6621JK2002D
147D	TRAY, BUTTER	3390JJ2003A	410B	BRACKET ASSEMBLY, DOOR	4811JJ2004B
149C	SHELF ASSEMBLY, R	5027JJ2010B	410G	CAPACITOR, DRAWING	0CZZJB2003H
149E	SHELF ASSEMBLY, R	5027JJ2009B	411A	POWER CORD ASSEMBLY	6411JK1006A
151A	TRAY ASSEMBLY, VEGETABLE	3391JJ1019E	418A	HEATER, SHEATH	5300JB1100J
151C	KNOB, SHUTTER	4940JJ2003B	420A	MOTOR(MECH), COOLING	4680JK1001B
154A	COVER, T/V	3550JJ1033A	501A	PWB(PCB) ASSEMBLY, MAIN	6871JB1213A
155B	SUPPORTER ASSEMBLY, COVER-T/V	4981JJ2001A	501B	PWB(PCB) ASSEMBLY, DISPLAY	6871JB3008A
158A	COVER, LAMP	3550JJ1040A	501F	COVER, PWB	3550JJ1042B
158E	COVER, LAMP	3550JJ1051A	503C	PWB(PCB) ASSEMBLY, DISPLAY	6871JB2046A
160B	DECO, TRAY	3806JL2005D	503D	CASE, DISPLAY	3110JJ1005A
161A	COVER, TRAY	3550JJ2026A	503E	COVER, DISPLAY	3550JJ2032A
167B	GLASS, SHELF	4890JL1002K	503G	DECO, CONTROL	3806JL1013A
168A	COVER, MAGIC ROOM	3550JJ1035A	600A	ICE MAKER ASSEMBLY, KIT	5989JA0002A
170A	TRAY ASSEMBLY, MEAT	3391JJ2004K	602A	HOLDER, BRACKET	4930JA30037A
200A	DOOR ASSEMBLY, F	3581JJ8018D	607A	HOLDER, BRACKET	4930JJ2013A
201A	DOOR FOAM ASSEMBLY, F	5433JJ0018W	610A	COVER, SENSOR	3550JJ2020A
203A	GASKET ASSEMBLY, DOOR	4987JJ1004E	611C	COVER, FILTER	3550JL1008B
205A	BASKET, DOOR	5004JJ1042B	611D	COVER, FILTER	3550JJ2028A
205B	BASKET, TILT	5004JJ2005B	611E	FILTER ASSEMBLY, HEAD	5231JA2005A
205C	BASKET, TILT	5004JJ2005A	615A	TANK ASSEMBLY, WATER	4839JJ2003A
210A	STOPPER, DOOR	4620JJ2005A	616A	TUBE, INJECT	5210JJ2001A
210B	STOPPER, DOOR	4620JJ2008A	616B	TUBE, PE	5210JA3005N
212A	HANDLE, F	3650JJ1017H	616D	TUBE, PE	5210JA3004M
212G	NAME PLATE, P(H)	4140JD2001C	616E	TUBE, PE	5210JA3005N
230A	DOOR ASSEMBLY, R	3581JJ8025K	616F	TUBE, PE	5210JA3004B
231A	DOOR FOAM ASSEMBLY, R	5433JJ0033F	616G	TUBE, PE	5210JA3005P
233A	GASKET ASSEMBLY, DOOR	4987JJ1004B	618A	TUBE, INJECT	5210JJ3005B
237A	GUIDE, BOTTLE	4974JJ2012A	619A	VALVE, WATER	5220JA2013A
237C	GUIDE, DRAWER	4974JJ1021A	619B	COVER, VALVE	3550JJ2024A
241A	COVER, TRAY	3550JL2003H	619C	VALVE ASSEMBLY, WATER	5221JA2011A
241B	BASKET, DOOR	5004JJ1021A	621B	CONNECTOR (MECH), TUBE	4932JA3009A
241C	BASKET ASSEMBLY, DOOR	5005JJ2017A	622A	TUBE, INLET	5210JJ3002A
241D	BASKET ASSEMBLY, DOOR	5005JJ2020A	623A	CAP, COVER	5006JJ2004A
241E	BASKET ASSEMBLY, DOOR	5005JJ2018A	623B	CAP, COVER	5006JJ2003A
243A	STOPPER, DOOR	4620JJ3006C	623C	BAND (MECH)	4770JA3001A
244A	HANDLE, R	3650JJ2008E	625A	COVER, TUBE	3550JJ2034A
244B	HOLDER, HANDLE	4930JJ2009A	627A	HOLDER, PIPE	4930JA3054A
244C	HOLDER, HANDLE	4930JJ2010A	627B	HOLDER, BRACKET	4930JA3091A
244D	HOLDER, HANDLE	4930JJ2012A	628B	VALVE ASSEMBLY, WATER	5221JJ2002A
244K	HOLDER, HANDLE	4930JJ2011A	628C	VALVE, WATER	5220JB2001A
248E	DECO, TRAY	3806JJ2035A	628D	COVER, VALVE	3550JJ2058A
248F	SUPPORTER, HOLDER	4980JJ2005A	628E	COVER, VALVE	3550JJ2059A
248N	RAIL ASSEMBLY, SLIDE	5219JJ2002A	628F	TUBE, PE	5210JA3005B
248P	RAIL ASSEMBLY, SLIDE	5219JJ2002B	628G	HOLDER, PIPE	4930JA3087A
262A	HOLDER, BRACKET	4930JA3093A	629A	TANK, WATER	4838JJ1003A
262A	HOLDER, BRACKET	4930JA3093A	629B	CONNECTOR (MECH), TUBE	4932JA3009B
262A	HOLDER, BRACKET	4930JA3093A	629C	TUBE, PE	5210JA3004P
262B	HOLDER, BRACKET	4930JA3093B	700B	HANDLE ASSEMBLY, F	3651JJ0002B
262D	CLIP	4004JA3002A	700C	HANDLE ASSEMBLY, R	3651JJ1017F
276B	BUTTON, LEVER	5020JJ3001C	903A	COVER, LOWER	3550JJ0006C
278C	LEVER, SHUTTER	4510JJ2002A	903B	HOLDER, COVER LOWER	4930JJ2021A
279B	COVER, DISPENSER	3550JL1005D	903D	SENSOR	6500JK1003A
279C	DECO, DISPENSER	3806JJ2021D	903E	SENSOR	6500JK1004A
281A	COVER, HINGE	3550JJ1039C	B01	SCREW, DRAWING	1STZJA3004F
281B	HINGE ASSEMBLY, U	4775JJ2005A	S01	SCREW, DRAWING	1SZZJJ3010A
281C	HINGE ASSEMBLY, L	4775JJ2008A	S07	SCREW, DRAWING	4000W4A003A
281D	COVER, HINGE	3550JJ2043A	S22	SCREW, DRAWING	3J05696C
281E	CAP, HINGE	5006JJ3008C	S24	SCREW, DRAWING	1SZZJA3011B
281F	DECO, DRAIN	3806JJ2020D	S28	SCREW, DRAWING	3J05696V
281G	COVER, HINGE	3550JJ2044A	S38	SCREW, DRAWING	4J00415D
281H	HINGE ASSEMBLY, L	4775JJ2011A			
282B	HINGE ASSEMBLY, C	4775JJ8002C			
282E	CAP, HINGE	5006JJ2001F			

#EV#

LRDC22731WW

LOC	DESCRIPCION	NO. DE PARTE	LOC	DESCRIPCION	NO. DE PARTE
103A	HANDLE, BACK	3650JJ2003E	281E	CAP, HINGE	5006JJ3008A
103B	HANDLE, BACK	3650JJ2003A	281G	COVER, HINGE	3550JJ2044A
103C	COVER ASSEMBLY, LOWER	3551JJ1015B	281H	HINGE ASSEMBLY, L	4775JJ2011A
103E	RAIL, SLIDE	5218JJ3001A	282B	HINGE ASSEMBLY, C	4775JJ8002A
105A	DRAIN ASSEMBLY, PIPE-Z	5251JA3003B	282E	CAP, HINGE	5006JJ2001A
105F	SKIRT, LOWER	5070JJ3002A	282F	DECO, DUCT	3806JL2006E
106A	LEG ASSEMBLY, ADJUST	4779JJ2001A	282H	CAP, HINGE	5006JJ3004A
106B	WASHER, DRAWING	4J00382C	283B	HINGE, L	4774JJ3001A
120B	DUCT ASSEMBLY, MULTI	5209JJ1002A	284D	SCREW, DRAWING	1STZJA3004K
128A	GUIDE ASSEMBLY, RAIL	4975JJ2002A	285A	GUIDE ASSEMBLY, RAIL	4975JJ2007G
128B	GUIDE ASSEMBLY, RAIL	4975JJ2002B	286A	BUSH	4984JJ3003A
128C	GUIDE ASSEMBLY, RAIL	4975JJ2003C	301A	EVAPORATOR ASSEMBLY	5421JJ1001B
128G	LINK	4520JJ2001A	304A	COVER ASSEMBLY, BACK-M/C	3551JJ2008B
128M	GUIDE, AIR	4974JJ2011A	305B	ROLLER	4580JJ3001A
131A	BANK ASSEMBLY, ICE	5075JJ1001B	305B	ROLLER	4580JJ3001A
135C	COVER, GRILLE FAN	3550JJ2030A	305C	PIN, DRAWING	4J04238A
136A	TRAY ASSEMBLY, DRAWER	3391JJ1011B	305C	PIN, DRAWING	4J04238A
136B	TRAY, DRAWER	3390JJ1087A	307A	COMPRESSOR, SET ASSEMBLY	2521C-A5725
136F	TRAY ASSEMBLY, DRAWER	3391JJ1033B	308A	P.T.C ASSEMBLY	6748C-0004D
140A	SHELF ASSEMBLY, R	5027JJ1014D	309A	O.L.P	6750CR0004S
140B	SHELF ASSEMBLY, R	5027JJ1005A	310A	COVER, P.T.C	3550JA2042A
140F	SHELF ASSEMBLY, NET	5027JJ2005F	312A	RUBBER, SEAT	5040JA3031A
141A	SHELF ASSEMBLY, R	5027JJ1014B	313A	RUBBER, SEAT	5040JJ3007A
141B	SHELF ASSEMBLY, R	5027JJ1005A	314A	STOPPER, COMP	4620JA3009A
141C	SHELF ASSEMBLY, NET	5027JJ2005C	315A	COMP BASE ASSEMBLY, STD	3103JJ1001J
141D	SHELF ASSEMBLY, R	5027JJ2011B	317A	DRIER ASSEMBLY	5851JJ2002B
141E	SHELF ASSEMBLY, NET	5027JJ2005D	318A	HOLDER, DRIER	4930JJ3002A
142A	SHELF ASSEMBLY, R	5027JJ1013U	319A	TRAY, DRIP	3390JJ0003A
142B	SHELF ASSEMBLY, R	5027JJ1006A	319C	GUIDE, FAN	4974JJ1009A
142D	SHELF, NET	5026JJ2001L	319E	BRACKET, MOTOR	4810JJ2005A
142E	SHELF, NET	5026JJ2001M	323B	CONDENSER ASSEMBLY, WIRE	5403JJ1007A
145A	HOLDER, SHELF	4930JJ2003A	327A	CAP, DRAIN PIPE	5006JA3034A
145B	HOLDER, SHELF	4930JJ2004A	328A	RUBBER, DAMPING	4J03020A
145D	GUIDE, RAIL	4974JJ1012A	328B	RUBBER, DAMPING	4J04328A
145G	GUIDE ASSEMBLY, RAIL	4975JJ2005H	329A	FAN ASSEMBLY	5901JJ1005A
146D	CAN, SERVER	5044JJ1001A	329C	FAN ASSEMBLY	5901JJ1004B
147A	BANK, DAIRY	5074JJ1005A	332A	GRILLE ASSEMBLY, FAN	3531JJ1004A
147B	TRAY, EGG	3390JJ1014A	401A	CONTROLLER ASSEMBLY, (CIRC)	6615JB2005C
147C	COVER, BANK	3550JJ1017A	404A	MOTOR ASSEMBLY, REF FAN	4681JK1004A
147D	TRAY, BUTTER	3390JJ2003A	405A	BRACKET ASSEMBLY, MOTOR	4811JJ2002A
149C	SHELF ASSEMBLY, R	5027JJ2010B	405C	RUBBER, MOTOR-F	5040JA2009B
149E	SHELF ASSEMBLY, R	5027JJ2009B	405F	RUBBER, MOTOR-F	5040JA2004B
151A	TRAY ASSEMBLY, VEGETABLE	3391JJ1019E	406B	SWITCH, [PUSH]	6600JB1004A
151C	KNOB, SHUTTER	4940JJ2003B	409B	LAMP, [INCANDESCENT]	6912JK2002C
154A	COVER, TV	3550JJ1033A	409D	REFLECTOR, LAMP	3034JJ1002B
155B	SUPPORTER ASSEMBLY, COVER-TV	4981JJ2001A	410A	SOCKET ASSEMBLY, LAMP	6621JK2002D
158A	COVER, LAMP	3550JJ1040A	410B	BRACKET ASSEMBLY, DOOR	4811JJ2004B
158E	COVER, LAMP	3550JJ1051A	410G	CAPACITOR, DRAWING	0CZZJB2003H
160B	DECO, TRAY	3806JL2005D	411A	POWER CORD ASSEMBLY	6411JK1006A
161A	COVER, TRAY	3550JJ2026A	418A	HEATER, SHEATH	5300JB1100J
167B	GLASS, SHELF	4890JL1002K	420A	MOTOR(MECH), COOLING	4680JK1001B
168A	COVER, MAGIC ROOM	3550JJ1035A	501A	PWB(PCB) ASSEMBLY, MAIN	6871JB1213B
170A	TRAY ASSEMBLY, MEAT	3391JJ2004K	501F	COVER, PWB	3550JJ1042B
200A	DOOR ASSEMBLY, F	3581JJ8018A	503C	PWB(PCB) ASSEMBLY, DISPLAY	6871JB2046B
201A	DOOR FOAM ASSEMBLY, F	5433JJ0018H	503D	CASE, DISPLAY	3110JJ1005A
203A	GASKET ASSEMBLY, DOOR	4987JJ1004A	503E	COVER, DISPLAY	3550JJ2032A
205A	BASKET, DOOR	5004JJ1042B	503G	DECO, CONTROL	3806JL1010A
205B	BASKET, TILT	5004JJ2005B	600A	ICE MAKER ASSEMBLY, KIT	5989JA0002A
205C	BASKET, TILT	5004JJ2005A	602A	HOLDER, BRACKET	4930JA3037A
210A	STOPPER, DOOR	4620JJ2005A	607A	HOLDER, BRACKET	4930JJ2013A
210B	STOPPER, DOOR	4620JJ2008A	607A	HOLDER, BRACKET	4930JJ2013A
212A	HANDLE, F	3650JJ1017K	610A	COVER, SENSOR	3550JJ2020A
212G	NAME PLATE, P(H)	4140JD2001C	611C	COVER, FILTER	3550JL1008B
230A	DOOR ASSEMBLY, R	3581JJ8024A	611D	COVER, FILTER	3550JJ2028A
231A	DOOR FOAM ASSEMBLY, R	5433JJ0019D	616E	TUBE, PE	5210JA3005N
233A	GASKET ASSEMBLY, DOOR	4987JJ1004B	616F	TUBE, PE	5210JA3004B
237A	GUIDE, BOTTLE	4974JJ2012A	616G	TUBE, PE	5210JA3005E
237C	GUIDE, DRAWER	4974JJ1021A	618A	TUBE, INJECT	5210JJ3005B
241A	COVER, TRAY	3550JL2003H	619A	VALVE, WATER	5220JA2009B
241B	BASKET, DOOR	5004JJ1021A	619B	COVER, VALVE	3550JJ2024A
241C	BASKET ASSEMBLY, DOOR	5005JJ2017A	619C	VALVE ASSEMBLY, WATER	5221JA2008H
241D	BASKET ASSEMBLY, DOOR	5005JJ2020A	622A	TUBE, INLET	5210JJ3002A
241E	BASKET ASSEMBLY, DOOR	5005JJ2018A	623C	BAND (MECH)	4770JA3001A
243A	STOPPER, DOOR	4620JJ3006A	625A	COVER, TUBE	3550JJ2034A
244A	HANDLE, R	3650JJ2008R	627B	HOLDER, BRACKET	4930JA3091A
244B	HOLDER, HANDLE	4930JJ2009E	700B	HANDLE ASSEMBLY, F	3651JJ0002D
244C	HOLDER, HANDLE	4930JJ2010E	700C	HANDLE ASSEMBLY, R	3651JJ1017H
244D	HOLDER, HANDLE	4930JJ2012E	903A	COVER, LOWER	3550JJ0006A
244K	HOLDER, HANDLE	4930JJ2011E	903B	HOLDER, COVER LOWER	4930JJ2021A
248E	DECO, TRAY	3806JJ2035A	903D	SENSOR	6500JK1003A
248F	SUPPORTER, HOLDER	4980JJ2005A	903E	SENSOR	6500JK1004A
248N	RAIL ASSEMBLY, SLIDE	5219JJ2002A	B01	SCREW, DRAWING	1STZJA3004F
248P	RAIL ASSEMBLY, SLIDE	5219JJ2002B	S01	SCREW, DRAWING	1SZJJ3010A
262A	HOLDER, BRACKET	4930JA3093A	S07	SCREW, DRAWING	4000W4A003A
262D	CLIP	4004JA3002A	S22	SCREW, DRAWING	3J05696C
278C	LEVER, SHUTTER	4510JJ2002A	S24	SCREW, DRAWING	1SZZJA3011B
281A	COVER, HINGE	3550JJ2013A	S28	SCREW, DRAWING	3J05696W
281B	HINGE ASSEMBLY, U	4775JJ2003B	S38	SCREW, DRAWING	4J00415D
281C	HINGE ASSEMBLY, L	4775JJ2008A			
281D	COVER, HINGE	3550JJ2043A			

LOC	DESCRIPCION	NO. DE PARTE	LOC	DESCRIPCION	NO. DE PARTE
103A	HANDLE,BACK	3650JJ2003M	281D	COVER,HINGE	3550JJ2043A
103B	HANDLE,BACK	3650JJ2003L	281E	CAP,HINGE	5006JJ3008C
103C	COVER ASSEMBLY,LOWER	3551JJ1015F	281G	COVER,HINGE	3550JJ2044A
103E	RAIL,SLIDE	5218JJ3001A	281H	HINGE ASSEMBLY,L	4775JJ2011A
105A	DRAIN ASSEMBLY,PIPE-Z	5251JA3003B	282B	HINGE ASSEMBLY,C	4775JJ8002C
105F	SKIRT,LOWER	5070JJ3002A	282E	CAP,HINGE	5006JJ2001F
106A	LEG ASSEMBLY,ADJUST	4779JJ2001A	282F	DECO,DUCT	3806JL2006E
106B	WASHER,DRAWING	4J00382C	282H	CAP,HINGE	5006JJ3004A
120B	DUCT ASSEMBLY,MULTI	5209JJ1002A	283B	HINGE,L	4774JJ3001A
128A	GUIDE ASSEMBLY,RAIL	4975JJ2002A	284D	SCREW,DRAWING	1STZJA3004K
128A	GUIDE ASSEMBLY,RAIL	4975JJ2002A	285A	GUIDE ASSEMBLY,RAIL	3551JJ2007G
128B	GUIDE ASSEMBLY,RAIL	4975JJ2002B	286A	BUSH	4984JJ3003A
128C	GUIDE ASSEMBLY,RAIL	4975JJ2003C	301A	EVAPORATOR ASSEMBLY	5421JJ1001B
128G	LINK	4520JJ2001A	304A	COVER ASSEMBLY,BACK-M/C	3551JJ2008B
128M	GUIDE,AIR	4974JJ2011A	305B	ROLLER	4580JJ3001A
131A	BANK ASSEMBLY,ICE	5075JJ1001B	305B	ROLLER	4580JJ3001A
135C	COVER,GRILLE FAN	3550JJ2030A	305C	PIN,DRAWING	4J04238A
136A	TRAY ASSEMBLY,DRAWER	3391JJ1011B	307A	COMPRESSOR,SET ASSEMBLY	2521C-A5725
136B	TRAY,DRAWER	3390JJ1087A	308A	P.T.C ASSEMBLY	6748C-0004D
136F	TRAY ASSEMBLY,DRAWER	3391JJ1033B	309A	O.L.P	6750CR0004S
140A	SHELF ASSEMBLY,R	5027JJ1014D	310A	COVER,P.T.C	3550JA2042A
140B	SHELF ASSEMBLY,R	5027JJ1005A	312A	RUBBER,SEAT	5040JA3031A
140F	SHELF ASSEMBLY,NET	5027JJ2005F	313A	RUBBER,SEAT	5040JJ3007A
141A	SHELF ASSEMBLY,R	5027JJ1014B	314A	STOPPER,COMP	4620JA3009A
141B	SHELF ASSEMBLY,R	5027JJ1005A	315A	COMP BASE ASSEMBLY,STD	3103JJ1001J
141C	SHELF ASSEMBLY,NET	5027JJ2005C	317A	DRIER ASSEMBLY	5851JJ2002B
141D	SHELF ASSEMBLY,R	5027JJ2011B	318A	HOLDER,DRIER	4930JJ3002A
141E	SHELF ASSEMBLY,NET	5027JJ2005D	319A	TRAY,DRIP	3390JJ0003A
142A	SHELF ASSEMBLY,R	5027JJ1013U	319C	GUIDE,FAN	4974JJ1009A
142B	SHELF ASSEMBLY,R	5027JJ1006A	319E	BRACKET,MOTOR	4810JJ2005A
142D	SHELF,NET	5026JJ2001L	323B	CONDENSER ASSEMBLY,WIRE	5403JJ1007A
142E	SHELF,NET	5026JJ2001M	327A	CAP,DRAIN PIPE	5006JA3034A
145A	HOLDER,SHELF	4930JJ2003A	328A	RUBBER,DAMPING	4J03020A
145B	HOLDER,SHELF	4930JJ2004A	328B	RUBBER,DAMPING	4J04328A
145D	GUIDE,RAIL	4974JJ1012A	329A	FAN ASSEMBLY	5901JJ1005A
145G	GUIDE ASSEMBLY,RAIL	4975JJ2005H	329C	FAN ASSEMBLY	5901JJ1004B
146D	CAN,SERVER	5044JJ1001A	332A	GRILLE ASSEMBLY,FAN	3531JJ1004A
147A	BANK,DAIRY	5074JJ1005A	401A	CONTROLLER ASSEMBLY(CIRC)	6615JB2005C
147B	TRAY,EGG	3390JJ1014A	404A	MOTOR ASSEMBLY,REF FAN	4681JK1004A
147C	COVER,BANK	3550JJ1017A	405A	BRACKET ASSEMBLY,MOTOR	4811JJ2002A
147D	TRAY,BUTTER	3390JJ2003A	405C	RUBBER,MOTOR-F	5040JA2009B
149C	SHELF ASSEMBLY,R	5027JJ2010B	405F	RUBBER,MOTOR-F	5040JA2004B
149E	SHELF ASSEMBLY,R	5027JJ2009B	406B	SWITCH,[PUSH]	6600JB1004A
151A	TRAY ASSEMBLY,VEGETABLE	3391JJ1019E	409B	LAMP,[INCANDESCENT]	6912JK2002C
151C	KNOB,SHUTTER	4940JJ2003B	409D	REFLECTOR,LAMP	3034JJ1002B
154A	COVER,T/V	3550JJ1033A	410A	SOCKET ASSEMBLY,LAMP	6621JK2002D
155B	SUPPORTER ASSEMBLY,COVER-T/V	4981JJ2001A	410B	BRACKET ASSEMBLY,DOOR	4811JJ2004B
158A	COVER,LAMP	3550JJ1040A	410G	CAPACITOR,DRAWING	0CZZJB2003H
158E	COVER,LAMP	3550JJ1051A	411A	POWER CORD ASSEMBLY	6411JK1006A
160B	DECO,TRAY	3806JL2005D	418A	HEATER,SHEATH	5300JB1100J
161A	COVER,TRAY	3550JJ2026A	420A	MOTOR(MECH),COOLING	4680JK1001B
167B	GLASS,SHELF	4890JL1002K	501A	PWB(PCB) ASSEMBLY,MAIN	6871JB1213B
168A	COVER,MAGIC ROOM	3550JJ1035A	501F	COVER,PWB	3550JJ1042B
170A	TRAY ASSEMBLY,MEAT	3391JJ2004K	503C	PWB(PCB) ASSEMBLY,DISPLAY	6871JB2046B
200A	DOOR ASSEMBLY,F	3581JJ8018C	503D	CASE,DISPLAY	3110JJ1005A
201A	DOOR FOAM ASSEMBLY,F	5433JJ0018J	503E	COVER,DISPLAY	3550JJ2032A
203A	GASKET ASSEMBLY,DOOR	4987JJ1004E	503G	DECO,CONTROL	3806JL1010A
205A	BASKET,DOOR	5004JJ1042B	600A	ICE MAKER ASSEMBLY,KIT	5989JA0002A
205B	BASKET,TILT	5004JJ2005B	602A	HOLDER,BRACKET	4930JA3037A
205C	BASKET,TILT	5004JJ2005A	607A	HOLDER,BRACKET	4930JJ2013A
210A	STOPPER,DOOR	4620JJ2005A	607A	HOLDER,BRACKET	4930JJ2013A
210B	STOPPER,DOOR	4620JJ2008A	610A	COVER,SENSOR	3550JJ2020A
212A	HANDLE,F	3650JJ1017H	611C	COVER,FILTER	3550JL1008B
212G	NAME PLATE,P(H)	4140JD2001C	611D	COVER,FILTER	3550JJ2028A
230A	DOOR ASSEMBLY,R	3581JJ8024C	616E	TUBE,PE	5210JA3005N
231A	DOOR FOAM ASSEMBLY,R	5433JJ0019E	616F	TUBE,PE	5210JA3004B
233A	GASKET ASSEMBLY,DOOR	4987JJ1004F	616G	TUBE,PE	5210JA3005E
237A	GUIDE,BOTTLE	4974JJ2012A	618A	TUBE,INJECT	5210JJ3005B
237C	GUIDE,DRAWER	4974JJ1021A	619A	VALVE,WATER	5220JA2009B
241A	COVER,TRAY	3550JJ2003H	619B	COVER,VALVE	3550JJ2024A
241B	BASKET,DOOR	5004JJ1021A	619C	VALVE ASSEMBLY,WATER	5221JA2008H
241C	BASKET ASSEMBLY,DOOR	5005JJ2017A	622A	TUBE,INLET	5210JJ3002A
241D	BASKET ASSEMBLY,DOOR	5005JJ2020A	623C	BAND (MECH)	4770JA3001A
241E	BASKET ASSEMBLY,DOOR	5005JJ2018A	625A	COVER,TUBE	3550JJ2034A
243A	STOPPER,DOOR	4620JJ3006C	627B	HOLDER,BRACKET	4930JA3091A
244A	HANDLE,R	3650JJ2008E	700B	HANDLE ASSEMBLY,F	3651JJ0002B
244B	HOLDER,HANDLE	4930JJ2009A	700C	HANDLE ASSEMBLY,R	3651JJ1017F
244C	HOLDER,HANDLE	4930JJ2010A	903A	COVER,LOWER	3550JJ0006C
244D	HOLDER,HANDLE	4930JJ2012A	903B	HOLDER,COVER LOWER	4930JJ2021A
244K	HOLDER,HANDLE	4930JJ2011A	903D	SENSOR	6500JK1003A
248E	DECO,TRAY	3806JJ2035A	903E	SENSOR	6500JK1004A
248F	SUPPORTER,HOLDER	4980JJ2005A	B01	SCREW,DRAWING	1STZJA3004F
248N	RAIL ASSEMBLY,SLIDE	5219JJ2002A	S01	SCREW,DRAWING	1SZZJJ3010A
248P	RAIL ASSEMBLY,SLIDE	5219JJ2002B	S07	SCREW,DRAWING	4000W4A003A
262A	HOLDER,BRACKET	4930JA3093A	S22	SCREW,DRAWING	3J05696C
262D	CLIP	4004JA3002A	S24	SCREW,DRAWING	1SZZJA3011B
278C	LEVER,SHUTTER	4510JJ2002A	S28	SCREW,DRAWING	3J05696W
281A	COVER,HINGE	3550JJ2013C	S38	SCREW,DRAWING	4J00415D
281B	HINGE ASSEMBLY,U	4775JJ2003B			
281C	HINGE ASSEMBLY,L	4775JJ2008A			

LOC	DESCRIPCION	NO. DE PARTE	LOC	DESCRIPCION	NO. DE PARTE
103A	HANDLE, BACK	3650JJ2003M	281D	COVER, HINGE	3550JJ2043A
103B	HANDLE, BACK	3650JJ2003L	281E	CAP, HINGE	5006JJ3008C
103C	COVER ASSEMBLY, LOWER	3551JJ1015F	281G	COVER, HINGE	3550JJ2044A
103E	RAIL, SLIDE	5218JJ3001A	281H	HINGE ASSEMBLY, L	4775JJ2011A
105A	DRAIN ASSEMBLY, PIPE-Z	5251JA3003B	282B	HINGE ASSEMBLY, C	4775JJ3002C
105F	SKIRT, LOWER	5070JJ3002A	282E	CAP, HINGE	5006JJ2001F
106A	LEG ASSEMBLY, ADJUST	4779JJ2001A	282F	DECO, DUCT	3806JL2006E
106B	WASHER, DRAWING	4J00382C	282H	CAP, HINGE	5006JJ3004A
120B	DUCT ASSEMBLY, MULTI	5209JJ1002A	283B	HINGE, L	4774JJ3001A
128A	GUIDE ASSEMBLY, RAIL	4975JJ2002A	284D	SCREW, DRAWING	1STZJA3004K
128A	GUIDE ASSEMBLY, RAIL	4975JJ2002A	285A	GUIDE ASSEMBLY, RAIL	4975JJ2007G
128B	GUIDE ASSEMBLY, RAIL	4975JJ2002B	286A	BUSH	4984JJ3003A
128C	GUIDE ASSEMBLY, RAIL	4975JJ2003C	286A	BUSH	4984JJ3003A
128G	LINK	4520JJ2001A	301A	EVAPORATOR ASSEMBLY	5421JJ1001B
128M	GUIDE, AIR	4974JJ2011A	304A	COVER ASSEMBLY, BACK-M/C	3551JJ2008B
131A	BANK ASSEMBLY, ICE	5075JJ1001B	305B	ROLLER	4580JJ3001A
135C	COVER, GRILLE FAN	3550JJ2030A	305B	ROLLER	4580JJ3001A
136A	TRAY ASSEMBLY, DRAWER	3391JJ1011B	305C	PIN, DRAWING	4J04238A
136B	TRAY, DRAWER	3390JJ1087A	305C	PIN, DRAWING	4J04238A
136F	TRAY ASSEMBLY, DRAWER	3391JJ1033B	307A	COMPRESSOR, SET ASSEMBLY	2521C-A5725
140A	SHELF ASSEMBLY, R	5027JJ1014D	308A	P.T.C ASSEMBLY	6748C-0004D
140B	SHELF ASSEMBLY, R	5027JJ1005A	309A	O.L.P	6750CR0004S
140F	SHELF ASSEMBLY, NET	5027JJ2005F	310A	COVER, P.T.C	3550JA2042A
141A	SHELF ASSEMBLY, R	5027JJ1014B	312A	RUBBER, SEAT	5040JA3031A
141B	SHELF ASSEMBLY, R	5027JJ1005A	313A	RUBBER, SEAT	5040JJ3007A
141C	SHELF ASSEMBLY, NET	5027JJ2005C	314A	STOPPER, COMP	4620JA3009A
141D	SHELF ASSEMBLY, R	5027JJ2011B	315A	COMP BASE ASSEMBLY, STD	3103JJ1001J
141E	SHELF ASSEMBLY, NET	5027JJ2005D	317A	DRIER ASSEMBLY	5851JJ2002B
142A	SHELF ASSEMBLY, R	5027JJ1013U	318A	HOLDER, DRIER	4930JJ3002A
142B	SHELF ASSEMBLY, R	5027JJ1006A	319A	TRAY, DRIP	3390JJ0003A
142D	SHELF, NET	5026JJ2001L	319C	GUIDE, FAN	4974JJ1009A
142E	SHELF, NET	5026JJ2001M	319E	BRACKET, MOTOR	4810JJ2005A
145A	HOLDER, SHELF	4930JJ2003A	323B	CONDENSER ASSEMBLY, WIRE	5403JJ1007A
145B	HOLDER, SHELF	4930JJ2004A	327A	CAP, DRAIN PIPE	5006JA3034A
145D	GUIDE, RAIL	4974JJ1012A	328A	RUBBER, DAMPING	4J03020A
145G	GUIDE ASSEMBLY, RAIL	4975JJ2005H	328B	RUBBER, DAMPING	4J04328A
146D	CAN, SERVER	5044JJ1001A	328B	RUBBER, DAMPING	4J04328A
147A	BANK, DAIRY	5074JJ1005A	329A	FAN ASSEMBLY	5901JJ1005A
147B	TRAY, EGG	3390JJ1014A	329C	FAN ASSEMBLY	5901JJ1004B
147C	COVER, BANK	3550JJ1017A	332A	GRILLE ASSEMBLY, FAN	3531JJ1004A
147D	TRAY, BUTTER	3390JJ2003A	401A	CONTROLLER ASSEMBLY (CIRC)	6615JB2005C
149C	SHELF ASSEMBLY, R	5027JJ2010B	404A	MOTOR ASSEMBLY, REF FAN	4681JK1004A
149E	SHELF ASSEMBLY, R	5027JJ2009B	405A	BRACKET ASSEMBLY, MOTOR	4811JJ2002A
151A	TRAY ASSEMBLY, VEGETABLE	3391JJ1019E	405C	RUBBER, MOTOR-F	5040JA2009B
151C	KNOB, SHUTTER	4940JJ2003B	405F	RUBBER, MOTOR-F	5040JA2004B
154A	COVER, T/V	3550JJ1033A	406B	SWITCH, [PUSH]	6600JB1004A
155B	SUPPORTER ASSEMBLY, COVER-T/V	4981JJ2001A	409B	LAMP, [INCANDESCENT]	6912JK2002C
158A	COVER, LAMP	3550JJ1040A	409D	REFLECTOR, LAMP	3034JJ1002B
158E	COVER, LAMP	3550JJ1051A	410A	SOCKET ASSEMBLY, LAMP	6621JK2002D
160B	DECO, TRAY	3806JL2005D	410B	BRACKET ASSEMBLY, DOOR	4811JJ2004B
161A	COVER, TRAY	3550JJ2026A	410G	CAPACITOR, DRAWING	0CZZJB2003H
167B	GLASS, SHELF	4890JL1002K	411A	POWER CORD ASSEMBLY	6411JK1006A
168A	COVER, MAGIC ROOM	3550JJ1035A	418A	HEATER, SHEATH	5300JB1100J
170A	TRAY ASSEMBLY, MEAT	3391JJ2004K	420A	MOTOR (MECH), COOLING	4680JK1001B
200A	DOOR ASSEMBLY, F	3581JJ8018D	501A	PWB(PCB) ASSEMBLY, MAIN	6871JB1213B
201A	DOOR FOAM ASSEMBLY, F	5433JJ0018W	501F	COVER, PWB	3550JJ1042B
203A	GASKET ASSEMBLY, DOOR	4987JJ1004E	503C	PWB(PCB) ASSEMBLY, DISPLAY	6871JB2046B
205A	BASKET, DOOR	5004JJ1042B	503D	CASE, DISPLAY	3110JJ1005A
205B	BASKET, TILT	5004JJ2005B	503E	COVER, DISPLAY	3550JJ2032A
205C	BASKET, TILT	5004JJ2005A	503G	DECO, CONTROL	3806JL1010A
210A	STOPPER, DOOR	4620JJ2005A	600A	ICE MAKER ASSEMBLY, KIT	5989JA0002A
210B	STOPPER, DOOR	4620JJ2008A	602A	HOLDER, BRACKET	4930JA3037A
212A	HANDLE, F	3650JJ1017H	607A	HOLDER, BRACKET	4930JJ2013A
212G	NAME PLATE, P(H)	4140JD2001C	607A	HOLDER, BRACKET	4930JJ2013A
230A	DOOR ASSEMBLY, R	3581JJ8024D	610A	COVER, SENSOR	3550JJ2020A
231A	DOOR FOAM ASSEMBLY, R	5433JJ0019L	611C	COVER, FILTER	3550JL1008B
233A	GASKET ASSEMBLY, DOOR	4987JJ1004F	611D	COVER, FILTER	3550JJ2028A
237A	GUIDE, BOTTLE	4974JJ2012A	616E	TUBE, PE	5210JA3005N
237C	GUIDE, DRAWER	4974JJ1021A	616F	TUBE, PE	5210JA3004B
241A	COVER, TRAY	3550JL2003H	616G	TUBE, PE	5210JA3005E
241B	BASKET, DOOR	5004JJ1021A	618A	TUBE, INJECT	5210JJ3005B
241C	BASKET ASSEMBLY, DOOR	5005JJ2017A	619A	VALVE, WATER	5220JA2009B
241D	BASKET ASSEMBLY, DOOR	5005JJ2020A	619B	COVER, VALVE	3550JJ2024A
241E	BASKET ASSEMBLY, DOOR	5005JJ2018A	619C	VALVE ASSEMBLY, WATER	5221JA2008H
243A	STOPPER, DOOR	4620JJ3006C	622A	TUBE, INLET	5210JJ3002A
244A	HANDLE, R	3650JJ2008E	623C	BAND (MECH)	4770JA3001A
244B	HOLDER, HANDLE	4930JJ2009A	625A	COVER, TUBE	3550JJ2034A
244C	HOLDER, HANDLE	4930JJ2010A	627B	HOLDER, BRACKET	4930JA3091A
244D	HOLDER, HANDLE	4930JJ2012A	700B	HANDLE ASSEMBLY, F	3651JJ0002B
244K	HOLDER, HANDLE	4930JJ2011A	700C	HANDLE ASSEMBLY, R	3651JJ1017F
248E	DECO, TRAY	3806JJ2035A	903A	COVER, LOWER	3550JJ0006C
248F	SUPPORTER, HOLDER	4980JJ2005A	903B	HOLDER, COVER LOWER	4930JJ2021A
248N	RAIL ASSEMBLY, SLIDE	5219JJ2002A	903D	SENSOR	6500JK1003A
248P	RAIL ASSEMBLY, SLIDE	5219JJ2002B	903E	SENSOR	6500JK1004A
262A	HOLDER, BRACKET	4930JA3093A	B01	SCREW, DRAWING	1STZJA3004F
262D	CLIP	4004JA3002A	S01	SCREW, DRAWING	1SZZJJ3010A
278C	LEVER, SHUTTER	4510JJ2002A	S07	SCREW, DRAWING	4000W4A003A
281A	COVER, HINGE	3550JJ2013C	S22	SCREW, DRAWING	3J05696C
281B	HINGE ASSEMBLY, U	4775JJ2003B	S24	SCREW, DRAWING	1SZZJA3011B
281C	HINGE ASSEMBLY, L	4775JJ2008A	S28	SCREW, DRAWING	3J05696W
			S38	SCREW, DRAWING	4J00415D

LOC	DESCRIPCION	NO. DE PARTE	LOC	DESCRIPCION	NO. DE PARTE
103A	HANDLE, BACK	3650JJ2003E	281D	COVER, HINGE	3550JJ2043A
103B	HANDLE, BACK	3650JJ2003A	281E	CAP, HINGE	5006JJ3008A
103C	COVER ASSEMBLY, LOWER	3551JJ1015B	281G	COVER, HINGE	3550JJ2044A
103E	RAIL, SLIDE	5218JJ3001A	281H	HINGE ASSEMBLY, L	4775JJ2011A
105A	DRAIN ASSEMBLY, PIPE-Z	5251JA3003B	282B	HINGE ASSEMBLY, C	4775JJ8002A
105F	SKIRT, LOWER	5070JJ3002A	282E	CAP, HINGE	5006JJ2001A
106A	LEG ASSEMBLY, ADJUST	4779JJ2001A	282F	DECO, DUCT	3806JL2006E
106B	WASHER, DRAWING	4J00382C	282H	CAP, HINGE	5006JJ3004A
120B	DUCT ASSEMBLY, MULTI	5209JJ1002A	283B	HINGE, L	4774JJ3001A
128A	GUIDE ASSEMBLY, RAIL	4975JJ2002A	284D	SCREW, DRAWING	1STZJA3004K
128A	GUIDE ASSEMBLY, RAIL	4975JJ2002A	285A	GUIDE ASSEMBLY, RAIL	4975JJ2007G
128B	GUIDE ASSEMBLY, RAIL	4975JJ2002B	286A	BUSH	4984JJ3003A
128C	GUIDE ASSEMBLY, RAIL	4975JJ2003C	286A	BUSH	4984JJ3003A
128G	LINK	4520JJ2001A	301A	EVAPORATOR ASSEMBLY	5421JJ1001B
128M	GUIDE, AIR	4974JJ2011A	304A	COVER ASSEMBLY, BACK-M/C	3551JJ2008B
131A	BANK ASSEMBLY, ICE	5075JJ1001B	305B	ROLLER	4580JJ3001A
135C	COVER, GRILLE FAN	3550JJ2030A	305B	ROLLER	4580JJ3001A
136A	TRAY ASSEMBLY, DRAWER	3391JJ1011B	305C	PIN, DRAWING	4J04238A
136B	TRAY, DRAWER	3390JJ1087A	307A	COMPRESSOR, SET ASSEMBLY	2521C-A5725
136F	TRAY ASSEMBLY, DRAWER	3391JJ1033B	308A	P.T.C ASSEMBLY	6748C-0004D
140A	SHELF ASSEMBLY, R	5027JJ1014D	309A	O.L.P	6750CR0004S
140B	SHELF ASSEMBLY, R	5027JJ1005A	310A	COVER, P.T.C	3550JA2042A
140F	SHELF ASSEMBLY, NET	5027JJ2005F	312A	RUBBER, SEAT	5040JA3031A
141A	SHELF ASSEMBLY, R	5027JJ1014B	313A	RUBBER, SEAT	5040JJ3007A
141B	SHELF ASSEMBLY, R	5027JJ1005A	314A	STOPPER, COMP	4620JA3009A
141C	SHELF ASSEMBLY, NET	5027JJ2005C	315A	COMP BASE ASSEMBLY, STD	3103JJ1001J
141D	SHELF ASSEMBLY, R	5027JJ2011B	317A	DRIER ASSEMBLY	5851JJ2002B
141E	SHELF ASSEMBLY, NET	5027JJ2005D	318A	HOLDER, DRIER	4930JJ3002A
142A	SHELF ASSEMBLY, R	5027JJ1013U	319A	TRAY, DRIP	3390JJ0003A
142B	SHELF ASSEMBLY, R	5027JJ1006A	319C	GUIDE, FAN	4974JJ1009A
142D	SHELF, NET	5026JJ2001L	319E	BRACKET, MOTOR	4810JJ2005A
142E	SHELF, NET	5026JJ2001M	323B	CONDENSER ASSEMBLY, WIRE	5403JJ1007A
145A	HOLDER, SHELF	4930JJ2003A	327A	CAP, DRAIN PIPE	5006JA3034A
145B	HOLDER, SHELF	4930JJ2004A	328A	RUBBER, DAMPING	4J03020A
145D	GUIDE, RAIL	4974JJ1012A	328B	RUBBER, DAMPING	4J04328A
145G	GUIDE ASSEMBLY, RAIL	4975JJ2005H	329A	FAN ASSEMBLY	5901JJ1005A
146D	CAN, SERVER	5044JJ1001A	329C	FAN ASSEMBLY	5901JJ1004B
147A	BANK, DAIRY	5074JJ1005A	332A	GRILLE ASSEMBLY, FAN	3531JJ1004A
147B	TRAY, EGG	3390JJ1014A	401A	CONTROLLER ASSEMBLY (CIRC)	6615JB2005C
147C	COVER, BANK	3550JJ1017A	404A	MOTOR ASSEMBLY, REF FAN	4681JK1004A
147D	TRAY, BUTTER	3390JJ2003A	405A	BRACKET ASSEMBLY, MOTOR	4811JJ2002A
149C	SHELF ASSEMBLY, R	5027JJ2010B	405C	RUBBER, MOTOR-F	5040JA2009B
149E	SHELF ASSEMBLY, R	5027JJ2009B	405F	RUBBER, MOTOR-F	5040JA2004B
151A	TRAY ASSEMBLY, VEGETABLE	3391JJ1019E	406B	SWITCH, [PUSH]	6600JB1004A
151C	KNOB, SHUTTER	4940JJ2003B	409B	LAMP, [INCANDESCENT]	6912JK2002C
154A	COVER, T/V	3550JJ1033A	409D	REFLECTOR, LAMP	3034JJ1002B
155B	SUPPORTER ASSEMBLY, COVER-T/V	4981JJ2001A	410A	SOCKET ASSEMBLY, LAMP	6621JK2002D
158A	COVER, LAMP	3550JJ1040A	410B	BRACKET ASSEMBLY, DOOR	4811JJ2004B
158E	COVER, LAMP	3550JJ1051A	410G	CAPACITOR, DRAWING	0CZZJB2003H
160B	DECO, TRAY	3806JL2005D	411A	POWER CORD ASSEMBLY	6411JK1006A
161A	COVER, TRAY	3550JJ2026A	418A	HEATER, SHEATH	5300JB1100J
167B	GLASS, SHELF	4890JL1002K	420A	MOTOR (MECH), COOLING	4680JK1001B
168A	COVER, MAGIC ROOM	3550JJ1035A	501A	PWB(PCB) ASSEMBLY, MAIN	6871JB1213B
170A	TRAY ASSEMBLY, MEAT	3391JJ2004K	501F	COVER, PWB	3550JJ1042B
200A	DOOR ASSEMBLY, F	3581JJ8018B	503C	PWB(PCB) ASSEMBLY, DISPLAY	6871JB2046B
201A	DOOR FOAM ASSEMBLY, F	5433JJ0018D	503D	CASE, DISPLAY	3110JJ1005A
203A	GASKET ASSEMBLY, DOOR	4987JJ1004A	503E	COVER, DISPLAY	3550JJ2032A
205A	BASKET, DOOR	5004JJ1042B	503G	DECO, CONTROL	3806JL1010A
205B	BASKET, TILT	5004JJ2005B	600A	ICE MAKER ASSEMBLY, KIT	5989JA0002A
205C	BASKET, TILT	5004JJ2005A	602A	HOLDER, BRACKET	4930JA3037A
210A	STOPPER, DOOR	4620JJ2005A	607A	HOLDER, BRACKET	4930JJ2013A
210B	STOPPER, DOOR	4620JJ2008A	607A	HOLDER, BRACKET	4930JJ2013A
212A	HANDLE, F	3650JJ1017K	610A	COVER, SENSOR	3550JJ2020A
212G	NAME PLATE, P(H)	4140JD2001C	611C	COVER, FILTER	3550JL1008B
230A	DOOR ASSEMBLY, R	3581JJ8024P	611D	COVER, FILTER	3550JJ2028A
231A	DOOR FOAM ASSEMBLY, R	5433JJ0019B	616E	TUBE, PE	5210JA3005N
233A	GASKET ASSEMBLY, DOOR	4987JJ1004B	616F	TUBE, PE	5210JA3004B
237A	GUIDE, BOTTLE	4974JJ2012A	616G	TUBE, PE	5210JA3005E
237C	GUIDE, DRAWER	4974JJ1021A	618A	TUBE, INJECT	5210JJ3005B
241A	COVER, TRAY	3550JL2003H	619A	VALVE, WATER	5220JA2009B
241B	BASKET, DOOR	5004JJ1021A	619B	COVER, VALVE	3550JJ2024A
241C	BASKET ASSEMBLY, DOOR	5005JJ2017A	619C	VALVE ASSEMBLY, WATER	5221JA2008H
241D	BASKET ASSEMBLY, DOOR	5005JJ2020A	622A	TUBE, INLET	5210JJ3002A
241E	BASKET ASSEMBLY, DOOR	5005JJ2018A	623C	BAND (MECH)	4770JA3001A
243A	STOPPER, DOOR	4620JJ3006A	625A	COVER, TUBE	3550JJ2034A
244A	HANDLE, R	3650JJ2008R	627B	HOLDER, BRACKET	4930JA3091A
244B	HOLDER, HANDLE	4930JJ2009E	627B	HOLDER, BRACKET	4930JA3091A
244C	HOLDER, HANDLE	4930JJ2010E	700B	HANDLE ASSEMBLY, F	3651JJ0002D
244D	HOLDER, HANDLE	4930JJ2012E	700C	HANDLE ASSEMBLY, R	3651JJ1017H
244K	HOLDER, HANDLE	4930JJ2011E	903A	COVER, LOWER	3550JJ0006A
248E	DECO, TRAY	3806JJ2035A	903B	HOLDER, COVER LOWER	4930JJ2021A
248F	SUPPORTER, HOLDER	4980JJ2005A	903D	SENSOR	6500JK1003A
248N	RAIL ASSEMBLY, SLIDE	5219JJ2002A	903E	SENSOR	6500JK1004A
248P	RAIL ASSEMBLY, SLIDE	5219JJ2002B	B01	SCREW, DRAWING	1STZJA3004F
262A	HOLDER, BRACKET	4930JA3093A	S01	SCREW, DRAWING	1SZZJJ3010A
262D	CLIP	4004JA3002A	S07	SCREW, DRAWING	4000W4A003A
278C	LEVER, SHUTTER	4510JJ2002A	S22	SCREW, DRAWING	3J05696C
281A	COVER, HINGE	3550JJ2013A	S24	SCREW, DRAWING	1SZZJA3011B
281B	HINGE ASSEMBLY, U	4775JJ2003B	S28	SCREW, DRAWING	3J05696W
281C	HINGE ASSEMBLY, L	4775JJ2008A	S38	SCREW, DRAWING	4J00415D

LOC	DESCRIPCION	NO. DE PARTE	LOC	DESCRIPCION	NO. DE PARTE
103A	HANDLE,BACK	3650JJ2003F	248N	RAIL ASSEMBLY,SLIDE	5219JJ2002A
103B	HANDLE,BACK	3650JJ2003B	248P	RAIL ASSEMBLY,SLIDE	5219JJ2002B
103C	COVER ASSEMBLY,LOWER	3551JJ1015D	249G	GUIDE,RAIL	4974JJ1011A
103E	RAIL,SLIDE	5218JJ3001A	281A	COVER,HINGE	3550JJ2013B
105A	DRAIN ASSEMBLY,PIPE-Z	5251JA3003B	281B	HINGE ASSEMBLY,U	4775JJ2003B
105F	SKIRT,LOWER	5070JJ3002A	281C	HINGE ASSEMBLY,L	4775JJ2008A
106A	LEG ASSEMBLY,ADJUST	4779JJ2001A	282B	HINGE ASSEMBLY,C	4775JJ8002B
106B	WASHER,DRAWING	4J00382C	282E	CAP,HINGE	5006JJ2001E
120B	DUCT ASSEMBLY,MULTI	5209JJ1002A	282F	DECO,DUCT	3806JL2006E
125A	TRAY ASSEMBLY,ICE	3391JJ1009B	282H	CAP,HINGE	5006JJ3004A
128A	GUIDE ASSEMBLY,RAIL	4975JJ2002A	283B	HINGE,L	4774JJ3001A
128B	GUIDE ASSEMBLY,RAIL	4975JJ2002B	284D	SCREW,DRAWING	1STZJA3004K
131A	BANK ASSEMBLY,ICE	5075JJ1001B	285A	GUIDE ASSEMBLY,RAIL	4975JJ2007G
135C	COVER,GRILLE FAN	3550JJ2030A	286A	BUSH	4984JJ3003A
136A	TRAY ASSEMBLY,DRAWER	3391JJ1011B	301A	EVAPORATOR ASSEMBLY	5421JJ1001B
136B	TRAY,DRAWER	3390JJ1087A	304A	COVER ASSEMBLY,BACK-M/C	3551JJ2008B
136F	TRAY ASSEMBLY,DRAWER	3391JJ1033B	305B	ROLLER	4580JJ3001A
140B	SHELF ASSEMBLY,R	5027JJ2007B	305C	PIN,DRAWING	4J04238A
140B	SHELF ASSEMBLY,R	5027JJ2007B	307A	COMPRESSOR,SET ASSEMBLY	2521C-A5725
140D	SHELF,NET	5026JJ2001G	308A	P.T.C ASSEMBLY	6748C-0004D
140E	SHELF,NET	5026JJ2001H	309A	O.L.P	6750CR0004S
142D	SHELF,NET	5026JJ2001L	310A	COVER,P.T.C	3550JA2042A
142E	SHELF,NET	5026JJ2001M	312A	RUBBER,SEAT	5040JA3031A
143E	SHELF ASSEMBLY,R	5027JJ1008B	314A	STOPPER,COMP	4620JA3009A
143F	SHELF ASSEMBLY,R	5027JJ1008D	315A	COMP BASE ASSEMBLY,STD	3103JJ1001J
145A	HOLDER,SHELF	4930JJ2003A	317A	DRIER ASSEMBLY	5851JJ2002B
145B	HOLDER,SHELF	4930JJ2004A	318A	HOLDER,DRIER	4930JJ3002A
145D	GUIDE,RAIL	4974JJ1012A	319A	TRAY,DRIP	3390JJ0003A
145G	GUIDE ASSEMBLY,RAIL	4975JJ2005H	319C	GUIDE,FAN	4974JJ1009A
147A	BANK,DAIRY	5074JJ1005A	323B	CONDENSER ASSEMBLY,WIRE	5403JJ1007A
151A	TRAY ASSEMBLY,VEGETABLE	3391JJ1019E	327A	CAP,DRAIN PIPE	5006JA3034A
151C	KNOB,SHUTTER	4940JJ2003B	328A	RUBBER,DAMPING	4J03020A
154A	COVER,T/V	3550JJ1033A	328B	RUBBER,DAMPING	4J04328A
155B	SUPPORTER ASSEMBLY,COVER-TA	4981JJ2001A	329A	FAN ASSEMBLY	5901JJ1005A
158A	COVER,LAMP	3550JJ1040A	329C	FAN ASSEMBLY	5901JJ1004B
158E	COVER,LAMP	3550JJ1051A	332A	GRILLE ASSEMBLY,FAN	3531JJ1004A
160B	DECO,TRAY	3806JL2005D	401A	CONTROLLER ASSEMBLY(CIRC)	6615JB2005C
161A	COVER,TRAY	3550JJ2026A	404A	MOTOR(MECH),FAN	4680JK1002B
167B	GLASS,SHELF	4890JL1002K	405A	BRACKET ASSEMBLY,MOTOR	4811JJ2002B
168A	COVER,MAGIC ROOM	3550JJ1035A	405B	BRACKET,MOTOR	4810JA3007A
170A	TRAY ASSEMBLY,MEAT	3391JJ2004H	405C	RUBBER,MOTOR-N	J756-00008B
200A	DOOR ASSEMBLY,F	3581JJ8019S	406B	SWITCH,[PUSH]	6600JB1004A
201A	DOOR FOAM ASSEMBLY,F	5433JJ0018M	409B	LAMP,[INCANDESCENT]	6912JK2002C
203A	GASKET ASSEMBLY,DOOR	4987JJ1004A	409D	REFLECTOR,LAMP	3034JJ1002B
205A	BASKET,DOOR	5004JJ1042B	410A	SOCKET ASSEMBLY,LAMP	6621JK2002D
205B	BASKET,TILT	5004JJ2005B	410G	CAPACITOR,DRAWING	0CZZJB2003H
205C	BASKET,TILT	5004JJ2005A	411A	POWER CORD ASSEMBLY	6411JK1006A
212B	HANDLE,F	3650JJ0005B	418A	HEATER,SHEATH	5300JB1100J
212G	NAME PLATE,P(H)	4140JD2001C	420A	MOTOR(MECH),COOLING	4680JK1001B
230A	DOOR ASSEMBLY,R	3581JJ8024S	501A	PWB(PCB) ASSEMBLY,MAIN	6871JB1215A
231A	DOOR FOAM ASSEMBLY,R	5433JJ0019F	501F	COVER,PWB	3550JJ1042B
233A	GASKET ASSEMBLY,DOOR	4987JJ1004B	503C	PWB(PCB) ASSEMBLY,DISPLAY	6871JB2047A
237A	GUIDE,BOTTLE	4974JJ2021A	503D	CASE,DISPLAY	3110JJ1005A
237C	GUIDE,DRAWER	4974JJ1021A	503E	COVER,DISPLAY	3550JJ2031A
241A	COVER,TRAY	3550JL2003H	503G	DECO,CONTROL	3806JL1009A
241B	BASKET,DOOR	5004JJ1021A	602A	HOLDER,BRACKET	4930JA3037A
241C	BASKET,DOOR	5004JJ1031A	610A	COVER,SENSOR	3550JJ2020A
241D	BASKET,DOOR	5004JJ0001A	619B	COVER,VALVE	3550JJ2024A
241E	BASKET,DOOR	5004JJ1029A	621A	CONNECTOR (MECH),DOOR	4932JJ2001B
243A	STOPPER,DOOR	4620JJ3006B	623H	COVER,TUBE	3550JJ2036A
244E	CAP,HANDLE	5006JJ3016B	903A	COVER,LOWER	3550JJ0006B
244F	HOLDER,HANDLE	4930JJ1013B	903B	HOLDER,COVER LOWER	4930JJ2021A
244G	HOLDER,HANDLE	4930JJ1013A	903D	SENSOR	6500JK1003A
244H	HANDLE,R	3650JJ0006B	903E	SENSOR	6500JK1004A
244J	DECO,HANDLE	3806JJ1020C	B01	SCREW,DRAWING	1STZJA3004F
244M	DECO,HANDLE	3806JJ1020D	S01	SCREW,DRAWING	1SZZJJ3010A
248E	DECO,TRAY	3806JJ2035A	S07	SCREW,DRAWING	4000W4A003A
248F	SUPPORTER,HOLDER	4980JJ2005A	S22	SCREW,DRAWING	3J05696C
			S24	SCREW,DRAWING	1SZZJA3011B
			S28	SCREW,DRAWING	3J05696W
			S38	SCREW,DRAWING	4J00415D

LOC	DESCRIPCION	NO. DE PARTE	LOC	DESCRIPCION	NO. DE PARTE
103A	HANDLE,BACK	3650JJ2003E	249G	GUIDE,RAIL	4974JJ1011A
103B	HANDLE,BACK	3650JJ2003A	281A	COVER,HINGE	3550JJ2013A
103C	COVER ASSEMBLY,LOWER	3551JJ1015B	281B	HINGE ASSEMBLY,U	4775JJ2003B
103E	RAIL,SLIDE	5218JJ3001A	281C	HINGE ASSEMBLY,L	4775JJ2008A
105A	DRAIN ASSEMBLY,PIPE-Z	5251JA3003B	282B	HINGE ASSEMBLY,C	4775JJ8002A
105F	SKIRT,LOWER	5070JJ3002A	282E	CAP,HINGE	5006JJ2001A
106A	LEG ASSEMBLY,ADJUST	4779JJ2001A	282F	DECO,DUCT	3806JL2006E
106B	WASHER,DRAWING	4J00382C	282H	CAP,HINGE	5006JJ3004A
120B	DUCT ASSEMBLY,MULTI	5209JJ1002A	283B	HINGE,L	4774JJ3001A
125A	TRAY ASSEMBLY,ICE	3391JJ1009B	284D	SCREW,DRAWING	1STZJA3004K
128A	GUIDE ASSEMBLY,RAIL	4975JJ2002A	285A	GUIDE ASSEMBLY,RAIL	4975JJ2007G
128B	GUIDE ASSEMBLY,RAIL	4975JJ2002B	286A	BUSH	4984JJ3003A
131A	BANK ASSEMBLY,ICE	5075JJ1001B	301A	EVAPORATOR ASSEMBLY	5421JJ1001B
135C	COVER,GRILLE FAN	3550JJ2030A	304A	COVER ASSEMBLY,BACK-M/C	3551JJ2008B
136A	TRAY ASSEMBLY,DRAWER	3391JJ1011B	305B	ROLLER	4580JJ3001A
136B	TRAY,DRAWER	3390JJ1087A	305C	PIN,DRAWING	4J04238A
136F	TRAY ASSEMBLY,DRAWER	3391JJ1033B	307A	COMPRESSOR,SET ASSEMBLY	2521C-A5725
140B	SHELF ASSEMBLY,R	5027JJ2007B	308A	P.T.C ASSEMBLY	6748C-0004D
140D	SHELF,NET	5026JJ2001G	309A	O.L.P	6750CR0004S
140E	SHELF,NET	5026JJ2001H	310A	COVER,P.T.C	3550JA2042A
142D	SHELF,NET	5026JJ2001L	312A	RUBBER,SEAT	5040JA3031A
142E	SHELF,NET	5026JJ2001M	314A	STOPPER,COMP	4620JA3009A
143E	SHELF ASSEMBLY,R	5027JJ1008B	315A	COMP BASE ASSEMBLY,STD	3103JJ1001J
143F	SHELF ASSEMBLY,R	5027JJ1008D	317A	DRIER ASSEMBLY	5851JJ2002B
145A	HOLDER,SHELF	4930JJ2003A	318A	HOLDER,DRIER	4930JJ3002A
145B	HOLDER,SHELF	4930JJ2004A	319A	TRAY,DRIP	3390JJ0003A
145D	GUIDE,RAIL	4974JJ1012A	319C	GUIDE,FAN	4974JJ1009A
145G	GUIDE ASSEMBLY,RAIL	4975JJ2005H	323B	CONDENSER ASSEMBLY,WIRE	5403JJ1007A
147A	BANK,DAIRY	5074JJ1005A	327A	CAP,DRAIN PIPE	5006JA3034A
151A	TRAY ASSEMBLY,VEGETABLE	3391JJ1019E	328A	RUBBER,DAMPING	4J03020A
151C	KNOB,SHUTTER	4940JJ2003B	328B	RUBBER,DAMPING	4J04328A
154A	COVER,T/V	3550JJ1033A	329A	FAN ASSEMBLY	5901JJ1005A
155B	SUPPORTER ASSEMBLY,COVER-T/V	4981JJ2001A	329C	FAN ASSEMBLY	5901JJ1004B
158A	COVER,LAMP	3550JJ1040A	332A	GRILLE ASSEMBLY,FAN	3531JJ1004A
158E	COVER,LAMP	3550JJ1051A	401A	CONTROLLER ASSEMBLY(CIRC)	6615JB2005C
160B	DECO,TRAY	3806JL2005D	404A	MOTOR(MECH),FAN	4680JK1002B
161A	COVER,TRAY	3550JJ2026A	405A	BRACKET ASSEMBLY,MOTOR	4811JJ2002B
167B	GLASS,SHELF	4890JL1002K	405B	BRACKET,MOTOR	4810JA3007A
168A	COVER,MAGIC ROOM	3550JJ1035A	405C	RUBBER,MOTOR-N	J756-00008B
170A	TRAY ASSEMBLY,MEAT	3391JJ2004H	406B	SWITCH,[PUSH]	6600JB1004A
200A	DOOR ASSEMBLY,F	3581JJ8019N	409B	LAMP,[INCANDESCENT]	6912JK2002C
201A	DOOR FOAM ASSEMBLY,F	5433JJ0018G	409D	REFLECTOR,LAMP	3034JJ1002B
203A	GASKET ASSEMBLY,DOOR	4987JJ1004A	410A	SOCKET ASSEMBLY,LAMP	6621JK2002D
205A	BASKET,DOOR	5004JJ1042B	410G	CAPACITOR,DRAWING	0GZZJB2003H
205B	BASKET,TILT	5004JJ2005B	411A	POWER CORD ASSEMBLY	6411JK1006A
205C	BASKET,TILT	5004JJ2005A	418A	HEATER,SHEATH	5300JB1100J
212B	HANDLE,F	3650JJ0005A	420A	MOTOR(MECH),COOLING	4680JK1001B
212G	NAME PLATE,P(H)	4140JD2001C	501A	PWB(PCB) ASSEMBLY,MAIN	6871JB1215A
230A	DOOR ASSEMBLY,R	3581JJ8024N	501F	COVER,PWB	3550JJ1042B
231A	DOOR FOAM ASSEMBLY,R	5433JJ0019C	503C	PWB(PCB) ASSEMBLY,DISPLAY	6871JB2047A
233A	GASKET ASSEMBLY,DOOR	4987JJ1004B	503D	CASE,DISPLAY	3110JJ1005A
237A	GUIDE,BOTTLE	4974JJ2021A	503E	COVER,DISPLAY	3550JJ2031A
237C	GUIDE,DRAWER	4974JJ1021A	503G	DECO,CONTROL	3806JL1009A
241A	COVER,TRAY	3550JL2003H	602A	HOLDER,BRACKET	4930JA3037A
241B	BASKET,DOOR	5004JJ1021A	610A	COVER,SENSOR	3550JJ2020A
241C	BASKET,DOOR	5004JJ1031A	619B	COVER,VALVE	3550JJ2024A
241D	BASKET,DOOR	5004JJ0001A	621A	CONNECTOR (MECH),DOOR	4932JJ2001B
241E	BASKET,DOOR	5004JJ1029A	623H	COVER,TUBE	3550JJ2036A
243A	STOPPER,DOOR	4620JJ3006A	903A	COVER,LOWER	3550JJ0006A
244E	CAP,HANDLE	5006JJ3016A	903B	HOLDER,COVER LOWER	4930JJ2021A
244F	HOLDER,HANDLE	4930JJ1013B	903D	SENSOR	6500JK1003A
244G	HOLDER,HANDLE	4930JJ1013A	903E	SENSOR	6500JK1004A
244H	HANDLE,R	3650JJ0006A	B01	SCREW,DRAWING	1STZJA3004F
244J	DECO,HANDLE	3806JJ1020A	S01	SCREW,DRAWING	1SZZJJ3010A
244M	DECO,HANDLE	3806JJ1020B	S07	SCREW,DRAWING	4000W4A003A
248E	DECO,TRAY	3806JJ2035A	S22	SCREW,DRAWING	3J05696C
248F	SUPPORTER,HOLDER	4980JJ2005A	S24	SCREW,DRAWING	1SZZJA3011B
248N	RAIL ASSEMBLY,SLIDE	5219JJ2002A	S28	SCREW,DRAWING	3J05696W
248P	RAIL ASSEMBLY,SLIDE	5219JJ2002B	S38	SCREW,DRAWING	4J00415D

LRDN22720BK

LOC	DESCRIPCION	NO. DE PARTE	LOC	DESCRIPCION	NO. DE PARTE
103A	HANDLE,BACK	3650JJ2003M	281A	COVER,HINGE	3550JJ2013C
103B	HANDLE,BACK	3650JJ2003L	281B	HINGE ASSEMBLY,U	4775JJ2003B
103C	COVER ASSEMBLY,LOWER	3551JJ1015F	281C	HINGE ASSEMBLY,L	4775JJ2008A
103E	RAIL,SLIDE	5218JJ3001A	282B	HINGE ASSEMBLY,C	4775JJ8002C
105A	DRAIN ASSEMBLY,PIPE-Z	5251JA3003B	282E	CAP,HINGE	5006JJ2001F
105F	SKIRT,LOWER	5070JJ3002A	282F	DECO,DUCT	3806JL2006E
106A	LEG ASSEMBLY,ADJUST	4779JJ2001A	282H	CAP,HINGE	5006JJ3004A
106B	WASHER,DRAWING	4J00382C	283B	HINGE,L	4774JJ3001A
120B	DUCT ASSEMBLY,MULTI	5209JJ1002A	284D	SCREW,DRAWING	1STZJA3004K
125A	TRAY ASSEMBLY,ICE	3391JJ1009B	285A	GUIDE ASSEMBLY,RAIL	4975JJ2007G
128A	GUIDE ASSEMBLY,RAIL	4975JJ2002A	286A	BUSH	4984JJ3003A
128B	GUIDE ASSEMBLY,RAIL	4975JJ2002B	286A	BUSH	4984JJ3003A
131A	BANK ASSEMBLY,ICE	5075JJ1001B	301A	EVAPORATOR ASSEMBLY	5421JJ1001B
135C	COVER,GRILLE FAN	3550JJ2030A	304A	COVER ASSEMBLY,BACK-M/C	3551JJ2008B
136A	TRAY ASSEMBLY,DRAWER	3391JJ1011B	305B	ROLLER	4580JJ3001A
136B	TRAY,DRAWER	3390JJ1087A	305C	PIN,DRAWING	4J04238A
136F	TRAY ASSEMBLY,DRAWER	3391JJ1033B	307A	COMPRESSOR,SET ASSEMBLY	2521C-A5725
140B	SHELF ASSEMBLY,R	5027JJ2007B	308A	P.T.C ASSEMBLY	6748C-0004D
140B	SHELF ASSEMBLY,R	5027JJ2007B	309A	O.L.P	6750CR0004S
140D	SHELF,NET	5026JJ2001G	310A	COVER,P.T.C	3550JA2042A
140E	SHELF,NET	5026JJ2001H	312A	RUBBER,SEAT	5040JA3031A
142D	SHELF,NET	5026JJ2001L	314A	STOPPER,COMP	4620JA3009A
142E	SHELF,NET	5026JJ2001M	315A	COMP BASE ASSEMBLY,STD	3103JJ1001J
143E	SHELF ASSEMBLY,R	5027JJ1008B	317A	DRIER ASSEMBLY	5851JJ2002B
143F	SHELF ASSEMBLY,R	5027JJ1008D	318A	HOLDER,DRIER	4930JJ3002A
145A	HOLDER,SHELF	4930JJ2003A	319A	TRAY,DRIP	3390JJ0003A
145B	HOLDER,SHELF	4930JJ2004A	319C	GUIDE,FAN	4974JJ1009A
145D	GUIDE,RAIL	4974JJ1012A	323B	CONDENSER ASSEMBLY,WIRE	5403JJ1007A
145G	GUIDE ASSEMBLY,RAIL	4975JJ2005H	327A	CAP,DRAIN PIPE	5006JA3034A
147A	BANK,DAIRY	5074JJ1005A	328A	RUBBER,DAMPING	4J03020A
151A	TRAY ASSEMBLY,VEGETABLE	3391JJ1019E	328B	RUBBER,DAMPING	4J04328A
151C	KNOB,SHUTTER	4940JJ2003B	329A	FAN ASSEMBLY	5901JJ1005A
154A	COVER,T/V	3550JJ1033A	329C	FAN ASSEMBLY	5901JJ1004B
155B	SUPPORTER ASSEMBLY,COVER-T/V	4981JJ2001A	332A	GRILLE ASSEMBLY,FAN	3531JJ1004A
158A	COVER,LAMP	3550JJ1040A	401A	CONTROLLER ASSEMBLY(CIRC)	6615JB2005C
158E	COVER,LAMP	3550JJ1051A	404A	MOTOR(MECH),FAN	4680JK1002B
160B	DECO,TRAY	3806JL2005D	405A	BRACKET ASSEMBLY,MOTOR	4811JJ2002B
161A	COVER,TRAY	3550JJ2026A	405B	BRACKET,MOTOR	4810JA3007A
167B	GLASS,SHELF	4890JL1002K	405C	RUBBER,MOTOR-N	J756-00008B
168A	COVER,MAGIC ROOM	3550JJ1035A	406B	SWITCH,[PUSH]	6600JB1004A
170A	TRAY ASSEMBLY,MEAT	3391JJ2004H	409B	LAMP,[INCANDESCENT]	6912JK2002C
200A	DOOR ASSEMBLY,F	3581JJ8019T	409D	REFLECTOR,LAMP	3034JJ1002B
201A	DOOR FOAM ASSEMBLY,F	5433JJ0018R	410A	SOCKET ASSEMBLY,LAMP	6621JK2002D
203A	GASKET ASSEMBLY,DOOR	4987JJ1004E	410G	CAPACITOR,DRAWING	0CZZJB2003H
205A	BASKET,DOOR	5004JJ1042B	411A	POWER CORD ASSEMBLY	6411JK1006A
205B	BASKET,TILT	5004JJ2005B	418A	HEATER,SHEATH	5300JB1100J
205C	BASKET,TILT	5004JJ2005A	420A	MOTOR(MECH),COOLING	4680JK1001B
212B	HANDLE,F	3650JJ0005C	501A	PWB(PCB) ASSEMBLY,MAIN	6871JB1215A
212G	NAME PLATE,P(H)	4140JD2001C	501F	COVER,PWB	3550JJ1042B
230A	DOOR ASSEMBLY,R	3581JJ8024T	503C	PWB(PCB) ASSEMBLY,DISPLAY	6871JB2047A
231A	DOOR FOAM ASSEMBLY,R	5433JJ0019H	503D	CASE,DISPLAY	3110JJ1005A
233A	GASKET ASSEMBLY,DOOR	4987JJ1004F	503E	COVER,DISPLAY	3550JJ2031A
237A	GUIDE,BOTTLE	4974JJ2021A	503G	DECO,CONTROL	3806JL1009A
237C	GUIDE,DRAWER	4974JJ1021A	602A	HOLDER,BRACKET	4930JA3037A
241A	COVER,TRAY	3550JL2003H	610A	COVER,SENSOR	3550JJ2020A
241B	BASKET,DOOR	5004JJ1021A	619B	COVER,VALVE	3550JJ2024A
241C	BASKET,DOOR	5004JJ1031A	621A	CONNECTOR (MECH),DOOR	4932JJ2001B
241D	BASKET,DOOR	5004JJ0001A	623H	COVER,TUBE	3550JJ2036A
241E	BASKET,DOOR	5004JJ1029A	903A	COVER,LOWER	3550JJ0006C
243A	STOPPER,DOOR	4620JJ3006C	903B	HOLDER,COVER LOWER	4930JJ2021A
244E	CAP,HANDLE	5006JJ3016C	903D	SENSOR	6500JK1003A
244F	HOLDER,HANDLE	4930JJ1013B	903E	SENSOR	6500JK1004A
244G	HOLDER,HANDLE	4930JJ1013A	B01	SCREW,DRAWING	1STZJA3004F
244H	HANDLE,R	3650JJ0006C	S01	SCREW,DRAWING	1SZZJJ3010A
244J	DECO,HANDLE	3806JJ1020E	S03	BOLT,DRAWING	1BHZJA3003D
244M	DECO,HANDLE	3806JJ1020F	S07	SCREW,DRAWING	4000W4A003A
248E	DECO,TRAY	3806JJ2035A	S22	SCREW,DRAWING	3J05696C
248F	SUPPORTER,HOLDER	4980JJ2005A	S24	SCREW,DRAWING	1SZZJA3011B
248N	RAIL ASSEMBLY,SLIDE	5219JJ2002A	S28	SCREW,DRAWING	3J05696W
248P	RAIL ASSEMBLY,SLIDE	5219JJ2002B	S38	SCREW,DRAWING	4J00415D
249G	GUIDE,RAIL	4974JJ1011A			

LRDN22725ST

LOC	DESCRIPCION	NO. DE PARTE	LOC	DESCRIPCION	NO. DE PARTE
103A	HANDLE,BACK	3650JJ2003M	282B	HINGE ASSEMBLY,C	4775JJ8002C
103B	HANDLE,BACK	3650JJ2003L	282E	CAP,HINGE	5006JJ2001F
103C	COVER ASSEMBLY,LOWER	3551JJ1015F	282F	DECO,DUCT	3806JL2006E
103E	RAIL,SLIDE	5218JJ3001A	282H	CAP,HINGE	5006JJ3004A
105A	DRAIN ASSEMBLY,PIPE-Z	5251JA3003B	283B	HINGE,L	4774JJ3001A
105F	SKIRT,LOWER	5070JJ3002A	284D	SCREW,DRAWING	1STZJA3004K
106A	LEG ASSEMBLY,ADJUST	4779JJ2001A	285A	GUIDE ASSEMBLY,RAIL	4975JJ2007G
106B	WASHER,DRAWING	4J00382C	286A	BUSH	4984JJ3003A
120B	DUCT ASSEMBLY,MULTI	5209JJ1002A	286A	BUSH	4984JJ3003A
125A	TRAY ASSEMBLY,ICE	3391JJ1009B	301A	EVAPORATOR ASSEMBLY	5421JJ1001B
125D	HOLDER,BRACKET	4930JJ3007A	304A	COVER ASSEMBLY,BACK-M/C	3551JJ2008B
128A	GUIDE ASSEMBLY,RAIL	4975JJ2002A	305B	ROLLER	4580JJ3001A
128B	GUIDE ASSEMBLY,RAIL	4975JJ2002B	305C	PIN,DRAWING	4J04238A
131A	BANK ASSEMBLY,ICE	5075JJ1001B	307A	COMPRESSOR,SET ASSEMBLY	2521C-A5725
135C	COVER,GRILLE FAN	3550JJ2030A	308A	P.T.C ASSEMBLY	6748C-0004D
136A	TRAY ASSEMBLY,DRAWER	3391JJ1011B	309A	O.L.P	6750CR0004S
136B	TRAY,DRAWER	3390JJ1087A	310A	COVER,P.T.C	3550JA2042A
136F	TRAY ASSEMBLY,DRAWER	3391JJ1033B	312A	RUBBER,SEAT	5040JA3031A
140B	SHELF ASSEMBLY,R	5027JJ2007B	314A	STOPPER,COMP	4620JA3009A
140D	SHELF,NET	5026JJ2001G	315A	COMP BASE ASSEMBLY,STD	3103JJ1001J
140E	SHELF,NET	5026JJ2001H	317A	DRIER ASSEMBLY	5851JJ2002B
142D	SHELF,NET	5026JJ2001L	318A	HOLDER,DRIER	4930JJ3002A
142E	SHELF,NET	5026JJ2001M	319A	TRAY,DRIP	3390JJ0003A
143E	SHELF ASSEMBLY,R	5027JJ1008B	319C	GUIDE,FAN	4974JJ1009A
143F	SHELF ASSEMBLY,R	5027JJ1008D	323B	CONDENSER ASSEMBLY,WIRE	5403JJ1007A
145A	HOLDER,SHELF	4930JJ2003A	327A	CAP,DRAIN PIPE	5006JA3034A
145B	HOLDER,SHELF	4930JJ2004A	328A	RUBBER,DAMPING	4J03020A
145D	GUIDE,RAIL	4974JJ1012A	328B	RUBBER,DAMPING	4J04328A
145G	GUIDE ASSEMBLY,RAIL	4975JJ2005H	329A	FAN ASSEMBLY	5901JJ1005A
146A	CAN STORAGE,LOWER	5047JJ1001A	329C	FAN ASSEMBLY	5901JJ1004B
147A	BANK,DAIRY	5074JJ1005A	332A	GRILLE ASSEMBLY,FAN	3531JJ1004A
151A	TRAY ASSEMBLY,VEGETABLE	3391JJ1020C	401A	CONTROLLER ASSEMBLY(CIRC)	6615JB2005C
151C	KNOB,SHUTTER	4940JJ2003B	404A	MOTOR(MECH),FAN	4680JK1002B
154A	COVER,T/V	3550JL1006C	405A	BRACKET ASSEMBLY,MOTOR	4811JJ2002B
155B	SUPPORTER ASSEMBLY,COVER-T	4981JJ2001B	405B	BRACKET,MOTOR	4810JA3007A
158A	COVER,LAMP	3550JJ1040A	405C	RUBBER,MOTOR-N	J756-00008B
158E	COVER,LAMP	3550JJ1051A	406B	SWITCH,[PUSH]	6600JB1004A
167B	GLASS,SHELF	4890JL1002H	409B	LAMP,[INCANDESCENT]	6912JK2002C
170A	TRAY ASSEMBLY,MEAT	3391JJ2004H	409D	REFLECTOR,LAMP	3034JJ1002B
200A	DOOR ASSEMBLY,F	3581JJ8019C	410A	SOCKET ASSEMBLY,LAMP	6621JK2002D
201A	DOOR FOAM ASSEMBLY,F	5433JJ0018X	410G	CAPACITOR,DRAWING	0CZZJB2003H
203A	GASKET ASSEMBLY,DOOR	4987JJ1004E	411A	POWER CORD ASSEMBLY	6411JK1006A
205A	BASKET,DOOR	5004JJ1042B	418A	HEATER,SHEATH	5300JB1100J
205B	BASKET,TILT	5004JJ2005B	420A	MOTOR(MECH),COOLING	4680JK1001B
205C	BASKET,TILT	5004JJ2005A	501A	PWB(PCB) ASSEMBLY,MAIN	6871JB1215A
212A	HANDLE,F	3650JJ1017H	501F	COVER,PWB	3550JJ1042B
212G	NAME PLATE,P(H)	4140JD2001C	503C	PWB(PCB) ASSEMBLY,DISPLAY	6871JB2047A
230A	DOOR ASSEMBLY,R	3581JJ8024C	503D	CASE,DISPLAY	3110JJ1005A
231A	DOOR FOAM ASSEMBLY,R	5433JJ0019E	503E	COVER,DISPLAY	3550JJ2031A
233A	GASKET ASSEMBLY,DOOR	4987JJ1004F	503G	DECO,CONTROL	3806JL1009A
237A	GUIDE,BOTTLE	4974JJ2021A	602A	HOLDER,BRACKET	4930JA3037A
237C	GUIDE,DRAWER	4974JJ1021A	607A	HOLDER,BRACKET	4930JJ2013A
241A	COVER,TRAY	3550JL2003H	610A	COVER,SENSOR	3550JJ2020A
241B	BASKET,DOOR	5004JJ1021A	619B	COVER,VALVE	3550JJ2024A
241C	BASKET,DOOR	5004JJ1031A	621A	CONNECTOR (MECH),DOOR	4932JJ2001B
241D	BASKET,DOOR	5004JJ0001A	623H	COVER,TUBE	3550JJ2036A
241E	BASKET,DOOR	5004JJ1029A	700B	HANDLE ASSEMBLY,F	3651JJ0002B
243A	STOPPER,DOOR	4620JJ3006C	700C	HANDLE ASSEMBLY,R	3651JJ1017F
244A	HANDLE,R	3650JJ2008E	903A	COVER,LOWER	3550JJ0006C
244B	HOLDER,HANDLE	4930JJ2009A	903B	HOLDER,COVER LOWER	4930JJ2021A
244C	HOLDER,HANDLE	4930JJ2010A	903D	SENSOR	6500JK1003A
244D	HOLDER,HANDLE	4930JJ2012A	903E	SENSOR	6500JK1004A
244K	HOLDER,HANDLE	4930JJ2011A	B01	SCREW,DRAWING	1STZJA3004F
248E	DECO,TRAY	3806JJ2035A	S01	SCREW,DRAWING	1SZZJJ3010A
248F	SUPPORTER,HOLDER	4980JJ2005A	S07	SCREW,DRAWING	4000W4A003A
248N	RAIL ASSEMBLY,SLIDE	5219JJ2002A	S22	SCREW,DRAWING	3J05696C
248P	RAIL ASSEMBLY,SLIDE	5219JJ2002B	S24	SCREW,DRAWING	1SZZJA3011B
249G	GUIDE,RAIL	4974JJ1011A	S28	SCREW,DRAWING	3J05696W
281A	COVER,HINGE	3550JJ2013C	S38	SCREW,DRAWING	4J00415D
281B	HINGE ASSEMBLY,U	4775JJ2003B			
281C	HINGE ASSEMBLY,L	4775JJ2008A			

LRDN22711TT

LOC	DESCRIPCION	NO. DE PARTE	LOC	DESCRIPCION	NO. DE PARTE
103A	HANDLE,BACK	3650JJ2003M	281C	HINGE ASSEMBLY,L	4775JJ2008A
103B	HANDLE,BACK	3650JJ2003L	282B	HINGE ASSEMBLY,C	4775JJ8002C
103C	COVER ASSEMBLY,LOWER	3551JJ1015F	282E	CAP,HINGE	5006JJ2001F
103E	RAIL,SLIDE	5218JJ3001A	282F	DECO,DUCT	3806JL2006E
105A	DRAIN ASSEMBLY,PIPE-Z	5251JA3003B	282H	CAP,HINGE	5006JJ3004A
105F	SKIRT,LOWER	5070JJ3002A	283B	HINGE,L	4774JJ3001A
106A	LEG ASSEMBLY,ADJUST	4779JJ2001A	284D	SCREW,DRAWING	1STZJA3004K
106B	WASHER,DRAWING	4J00382C	285A	GUIDE ASSEMBLY,RAIL	4975JJ2007G
120B	DUCT ASSEMBLY,MULTI	5209JJ1002A	286A	BUSH	4984JJ3003A
125A	TRAY ASSEMBLY,ICE	3391JJ1009B	301A	EVAPORATOR ASSEMBLY	5421JJ1001B
128A	GUIDE ASSEMBLY,RAIL	4975JJ2002A	304A	COVER ASSEMBLY,BACK-M/C	3551JJ2008B
128B	GUIDE ASSEMBLY,RAIL	4975JJ2002B	305B	ROLLER	4580JJ3001A
131A	BANK ASSEMBLY,ICE	5075JJ1001B	305C	PIN,DRAWING	4J04238A
135C	COVER,GRILLE FAN	3550JJ2030A	307A	COMPRESSOR,SET ASSEMBLY	2521C-A5725
136A	TRAY ASSEMBLY,DRAWER	3391JJ1011B	308A	P.T.C ASSEMBLY	6748C-0004D
136B	TRAY,DRAWER	3390JJ1087A	309A	O.L.P	6750CR0004S
136F	TRAY ASSEMBLY,DRAWER	3391JJ1033B	310A	COVER,P.T.C	3550JA2042A
140B	SHELF ASSEMBLY,R	5027JJ2007B	312A	RUBBER,SEAT	5040JA3031A
140B	SHELF ASSEMBLY,R	5027JJ2007B	314A	STOPPER,COMP	4620JA3009A
140D	SHELF,NET	5026JJ2001G	315A	COMP BASE ASSEMBLY,STD	3103JJ1001J
140E	SHELF,NET	5026JJ2001H	317A	DRIER ASSEMBLY	5851JJ2002B
142D	SHELF,NET	5026JJ2001L	318A	HOLDER,DRIER	4930JJ3002A
142E	SHELF,NET	5026JJ2001M	319A	TRAY,DRIP	3390JJ0003A
143E	SHELF ASSEMBLY,R	5027JJ1008B	319C	GUIDE,FAN	4974JJ1009A
143F	SHELF ASSEMBLY,R	5027JJ1008D	323B	CONDENSER ASSEMBLY,WIRE	5403JJ1007A
145A	HOLDER,SHELF	4930JJ2003A	327A	CAP,DRAIN PIPE	5006JA3034A
145B	HOLDER,SHELF	4930JJ2004A	328A	RUBBER,DAMPING	4J03020A
145D	GUIDE,RAIL	4974JJ1012A	328B	RUBBER,DAMPING	4J04328A
145G	GUIDE ASSEMBLY,RAIL	4975JJ2005H	328B	RUBBER,DAMPING	4J04328A
147A	BANK,DAIRY	5074JJ1005A	329A	FAN ASSEMBLY	5901JJ1005A
151A	TRAY ASSEMBLY,VEGETABLE	3391JJ1019E	329C	FAN ASSEMBLY	5901JJ1004B
151C	KNOB,SHUTTER	4940JJ2003B	332A	GRILLE ASSEMBLY,FAN	3531JJ1004A
154A	COVER,T/V	3550JJ1033A	401A	CONTROLLER ASSEMBLY(CIRC)	6615JB2005C
155B	SUPPORTER ASSEMBLY,COVER-TA	4081JJ2001A	404A	MOTOR(MECH),FAN	4680JK1002B
158A	COVER,LAMP	3550JJ1040A	405A	BRACKET ASSEMBLY,MOTOR	4811JJ2002B
158E	COVER,LAMP	3550JJ1051A	405B	BRACKET,MOTOR	4810JA3007A
160B	DECO,TRAY	3806JL2005D	405C	RUBBER,MOTOR-N	J756-00008B
161A	COVER,TRAY	3550JJ2026A	406B	SWITCH,[PUSH]	6600JB1004A
167B	GLASS,SHELF	4890JL1002K	409B	LAMP,[INCANDESCENT]	6912JK2002C
168A	COVER,MAGIC ROOM	3550JJ1035A	409D	REFLECTOR,LAMP	3034JJ1002B
170A	TRAY ASSEMBLY,MEAT	3391JJ2004H	410A	SOCKET ASSEMBLY,LAMP	6621JK2002D
200A	DOOR ASSEMBLY,F	3581JJ8019D	410G	CAPACITOR,DRAWING	0CZZJB2003H
201A	DOOR FOAM ASSEMBLY,F	5433JJ0018V	411A	POWER CORD ASSEMBLY	6411JK1006A
203A	GASKET ASSEMBLY,DOOR	4987JJ1004E	418A	HEATER,SHEATH	5300JB1100J
205A	BASKET,DOOR	5004JJ1042B	420A	MOTOR(MECH),COOLING	4680JK1001B
205B	BASKET,TILT	5004JJ2005B	501A	PWB(PCB) ASSEMBLY,MAIN	6871JB1215A
205C	BASKET,TILT	5004JJ2005A	501F	COVER,PWB	3550JJ1042B
212A	HANDLE,F	3650JJ1017H	503C	PWB(PCB) ASSEMBLY,DISPLAY	6871JB2047A
212G	NAME PLATE,P(H)	4140JD2001C	503D	CASE,DISPLAY	3110JJ1005A
230A	DOOR ASSEMBLY,R	3581JJ8024D	503E	COVER,DISPLAY	3550JJ2031A
231A	DOOR FOAM ASSEMBLY,R	5433JJ0019L	503G	DECO,CONTROL	3806JL1009A
233A	GASKET ASSEMBLY,DOOR	4987JJ1004F	602A	HOLDER,BRACKET	4930JA3037A
237A	GUIDE,BOTTLE	4974JJ2021A	607A	HOLDER,BRACKET	4930JJ2013A
237C	GUIDE,DRAWER	4974JJ1021A	607A	HOLDER,BRACKET	4930JJ2013A
241A	COVER,TRAY	3550JL2003H	610A	COVER,SENSOR	3550JJ2020A
241B	BASKET,DOOR	5004JJ1021A	619B	COVER,VALVE	3550JJ2024A
241C	BASKET,DOOR	5004JJ1031A	621A	CONNECTOR (MECH),DOOR	4932JJ2001B
241D	BASKET,DOOR	5004JJ0001A	623H	COVER,TUBE	3550JJ2036A
241E	BASKET,DOOR	5004JJ1029A	700B	HANDLE ASSEMBLY,F	3651JJ0002B
243A	STOPPER,DOOR	4620JJ3006C	700C	HANDLE ASSEMBLY,R	3651JJ1017F
244A	HANDLE,R	3650JJ2008E	903A	COVER,LOWER	3550JJ0006C
244B	HOLDER,HANDLE	4930JJ2009A	903B	HOLDER,COVER LOWER	4930JJ2021A
244C	HOLDER,HANDLE	4930JJ2010A	903D	SENSOR	6500JK1003A
244D	HOLDER,HANDLE	4930JJ2012A	903E	SENSOR	6500JK1004A
244K	HOLDER,HANDLE	4930JJ2011A	B01	SCREW,DRAWING	1STZJA3004F
248E	DECO,TRAY	3806JJ2035A	S01	SCREW,DRAWING	1SZZJJ3010A
248F	SUPPORTER,HOLDER	4980JJ2005A	S07	SCREW,DRAWING	4000W4A003A
248N	RAIL ASSEMBLY,SLIDE	5219JJ2002A	S22	SCREW,DRAWING	3J05696C
248P	RAIL ASSEMBLY,SLIDE	5219JJ2002B	S24	SCREW,DRAWING	1SZZJA3011B
249G	GUIDE,RAIL	4974JJ1011A	S28	SCREW,DRAWING	3J05696W
281A	COVER,HINGE	3550JJ2013C	S38	SCREW,DRAWING	4J00415D
281B	HINGE ASSEMBLY,U	4775JJ2003B			

LOC	DESCRIPCION	NO. DE PARTE	LOC	DESCRIPCION	NO. DE PARTE
103A	HANDLE,BACK	3650JJ2003M	282B	HINGE ASSEMBLY,C	4775JJ8002C
103B	HANDLE,BACK	3650JJ2003L	282E	CAP,HINGE	5006JJ2001F
103C	COVER ASSEMBLY,LOWER	3551JJ1015F	282F	DECO,DUCT	3806JL2006E
103E	RAIL,SLIDE	5218JJ3001A	282H	CAP,HINGE	5006JJ3004A
105A	DRAIN ASSEMBLY,PIPE-Z	5251JA3003B	283B	HINGE,L	4774JJ3001A
105F	SKIRT,LOWER	5070JJ3002A	284D	SCREW,DRAWING	1STZJA3004K
106A	LEG ASSEMBLY,ADJUST	4779JJ2001A	285A	GUIDE ASSEMBLY,RAIL	4975JJ2007G
106B	WASHER,DRAWING	4J00382C	286A	BUSH	4984JJ3003A
120B	DUCT ASSEMBLY,MULTI	5209JJ1002A	286A	BUSH	4984JJ3003A
125A	TRAY ASSEMBLY,ICE	3391JJ1009B	301A	EVAPORATOR ASSEMBLY	5421JJ1001B
125D	HOLDER,BRACKET	4930JJ3007A	304A	COVER ASSEMBLY,BACK-M/C	3551JJ2008B
128A	GUIDE ASSEMBLY,RAIL	4975JJ2002A	305B	ROLLER	4580JJ3001A
128B	GUIDE ASSEMBLY,RAIL	4975JJ2002B	305C	PIN,DRAWING	4J04238A
131A	BANK ASSEMBLY,ICE	5075JJ1001B	305C	PIN,DRAWING	4J04238A
135C	COVER,GRILLE FAN	3550JJ2030A	307A	COMPRESSOR,SET ASSEMBLY	2521C-A5725
136A	TRAY ASSEMBLY,DRAWER	3391JJ1011B	308A	P.T.C ASSEMBLY	6748C-0004D
136B	TRAY,DRAWER	3390JJ1087A	309A	O.L.P	6750CR0004S
136F	TRAY ASSEMBLY,DRAWER	3391JJ1033B	310A	COVER,P.T.C	3550JA2042A
140B	SHELF ASSEMBLY,R	5027JJ2007B	312A	RUBBER,SEAT	5040JA3031A
140D	SHELF,NET	5026JJ2001G	314A	STOPPER,COMP	4620JA3009A
140E	SHELF,NET	5026JJ2001H	315A	COMP BASE ASSEMBLY,STD	3103JJ1001J
142D	SHELF,NET	5026JJ2001L	317A	DRIER ASSEMBLY	5851JJ2002B
142E	SHELF,NET	5026JJ2001M	318A	HOLDER,DRIER	4930JJ3002A
143E	SHELF ASSEMBLY,R	5027JJ1008B	319A	TRAY,DRIP	3390JJ0003A
143F	SHELF ASSEMBLY,R	5027JJ1008D	319C	GUIDE,FAN	4974JJ1009A
145A	HOLDER,SHELF	4930JJ2003A	323B	CONDENSER ASSEMBLY,WIRE	5403JJ1007A
145B	HOLDER,SHELF	4930JJ2004A	327A	CAP,DRAIN PIPE	5006JA3034A
145D	GUIDE,RAIL	4974JJ1012A	328A	RUBBER,DAMPING	4J03020A
145G	GUIDE ASSEMBLY,RAIL	4975JJ2005H	328B	RUBBER,DAMPING	4J04328A
146A	CAN STORAGE,LOWER	5047JJ1001A	329A	FAN ASSEMBLY	5901JJ1005A
147A	BANK,DAIRY	5074JJ1005A	329C	FAN ASSEMBLY	5901JJ1004B
151A	TRAY ASSEMBLY,VEGETABLE	3391JJ1020C	332A	GRILLE ASSEMBLY,FAN	3531JJ1004A
151C	KNOB,SHUTTER	4940JJ2003B	401A	CONTROLLER ASSEMBLY(CIRC)	6615JB2005C
154A	COVER,T/V	3550JL1006C	404A	MOTOR(MECH),FAN	4680JK1002B
155B	SUPPORTER ASSEMBLY,COVER-TA	4081JJ2001B	405A	BRACKET ASSEMBLY,MOTOR	4811JJ2002B
158A	COVER,LAMP	3550JJ1040A	405B	BRACKET,MOTOR	4810JA3007A
158E	COVER,LAMP	3550JJ1051A	405C	RUBBER,MOTOR-N	J756-00008B
167B	GLASS,SHELF	4890JL1002H	406B	SWITCH,[PUSH]	6600JB1004A
170A	TRAY ASSEMBLY,MEAT	3391JJ2004H	409B	LAMP,[INCANDESCENT]	6912JK2002C
200A	DOOR ASSEMBLY,F	3581JJ8019C	409D	REFLECTOR,LAMP	3034JJ1002B
201A	DOOR FOAM ASSEMBLY,F	5433JJ0018X	410A	SOCKET ASSEMBLY,LAMP	6621JK2002D
203A	GASKET ASSEMBLY,DOOR	4987JJ1004E	410G	CAPACITOR,DRAWING	0CZZJB2003H
205A	BASKET,DOOR	5004JJ1042B	411A	POWER CORD ASSEMBLY	6411JK1006A
205B	BASKET,TILT	5004JJ2005B	418A	HEATER,SHEATH	5300JB1100J
205C	BASKET,TILT	5004JJ2005A	420A	MOTOR(MECH),COOLING	4680JK1001B
212A	HANDLE,F	3650JJ1017H	501A	PWB(PCB) ASSEMBLY,MAIN	6871JB1215A
212G	NAME PLATE,P(H)	4140JD2001C	501F	COVER,PWB	3550JJ1042B
230A	DOOR ASSEMBLY,R	3581JJ8024C	503C	PWB(PCB) ASSEMBLY,DISPLAY	6871JB2047A
231A	DOOR FOAM ASSEMBLY,R	5433JJ0019E	503D	CASE,DISPLAY	3110JJ1005A
233A	GASKET ASSEMBLY,DOOR	4987JJ1004F	503E	COVER,DISPLAY	3550JJ2031A
237A	GUIDE,BOTTLE	4974JJ2021A	503G	DECO,CONTROL	3806JL1009A
237C	GUIDE,DRAWER	4974JJ1021A	602A	HOLDER,BRACKET	4930JA3037A
241A	COVER,TRAY	3550JL2003H	607A	HOLDER,BRACKET	4930JJ2013A
241B	BASKET,DOOR	5004JJ1021A	607A	HOLDER,BRACKET	4930JJ2013A
241C	BASKET,DOOR	5004JJ1031A	610A	COVER,SENSOR	3550JJ2020A
241D	BASKET,DOOR	5004JJ0001A	619B	COVER,VALVE	3550JJ2024A
241E	BASKET,DOOR	5004JJ1029A	621A	CONNECTOR (MECH),DOOR	4932JJ2001B
243A	STOPPER,DOOR	4620JJ3006C	623H	COVER,TUBE	3550JJ2036A
244A	HANDLE,R	3650JJ2008E	700B	HANDLE ASSEMBLY,F	3651JJ0002B
244B	HOLDER,HANDLE	4930JJ2009A	700C	HANDLE ASSEMBLY,R	3651JJ1017F
244C	HOLDER,HANDLE	4930JJ2010A	903A	COVER,LOWER	3550JJ0006C
244D	HOLDER,HANDLE	4930JJ2012A	903B	HOLDER,COVER LOWER	4930JJ2021A
244K	HOLDER,HANDLE	4930JJ2011A	903D	SENSOR	6500JK1003A
248E	DECO,TRAY	3806JJ2035A	903E	SENSOR	6500JK1004A
248F	SUPPORTER,HOLDER	4980JJ2005A	B01	SCREW,DRAWING	1STZJA3004F
248N	RAIL ASSEMBLY,SLIDE	5219JJ2002A	S01	SCREW,DRAWING	1SZZJJ3010A
248P	RAIL ASSEMBLY,SLIDE	5219JJ2002B	S07	SCREW,DRAWING	4000W4A003A
249G	GUIDE,RAIL	4974JJ1011A	S22	SCREW,DRAWING	3J05696C
281A	COVER,HINGE	3550JJ2013C	S24	SCREW,DRAWING	1SZZJA3011B
281B	HINGE ASSEMBLY,U	4775JJ2003B	S28	SCREW,DRAWING	3J05696W
281C	HINGE ASSEMBLY,L	4775JJ2008A	S38	SCREW,DRAWING	4J00415D

LRDN22711SW

LOC	DESCRIPCION	NO. DE PARTE	LOC	DESCRIPCION	NO. DE PARTE
103A	HANDLE,BACK	3650JJ2003E	281C	HINGE ASSEMBLY,L	4775JJ2008A
103B	HANDLE,BACK	3650JJ2003A	282B	HINGE ASSEMBLY,C	4775JJ8002A
103C	COVER ASSEMBLY,LOWER	3551JJ1015B	282E	CAP,HINGE	5006JJ2001A
103E	RAIL,SLIDE	5218JJ3001A	282F	DECO,DUCT	3806JL2006E
105A	DRAIN ASSEMBLY,PIPE-Z	5251JA3003B	282H	CAP,HINGE	5006JJ3004A
105F	SKIRT,LOWER	5070JJ3002A	283B	HINGE,L	4774JJ3001A
106A	LEG ASSEMBLY,ADJUST	4779JJ2001A	284D	SCREW,DRAWING	1STZJA3004K
106B	WASHER,DRAWING	4J00382C	285A	GUIDE ASSEMBLY,RAIL	4975JJ2007G
120B	DUCT ASSEMBLY,MULTI	5209JJ1002A	286A	BUSH	4984JJ3003A
125A	TRAY ASSEMBLY,ICE	3391JJ1009B	301A	EVAPORATOR ASSEMBLY	5421JJ1001B
128A	GUIDE ASSEMBLY,RAIL	4975JJ2002A	304A	COVER ASSEMBLY,BACK-M/C	3551JJ2008B
128B	GUIDE ASSEMBLY,RAIL	4975JJ2002B	305B	ROLLER	4580JJ3001A
131A	BANK ASSEMBLY,ICE	5075JJ1001B	305C	PIN,DRAWING	4J04238A
135C	COVER,GRILLE FAN	3550JJ2030A	307A	COMPRESSOR,SET ASSEMBLY	2521C-A5725
136A	TRAY ASSEMBLY,DRAWER	3391JJ1011B	308A	P.T.C ASSEMBLY	6748C-0004D
136B	TRAY,DRAWER	3390JJ1087A	309A	O.L.P	6750CR0004S
136F	TRAY ASSEMBLY,DRAWER	3391JJ1033B	310A	COVER,P.T.C	3550JA2042A
140B	SHELF ASSEMBLY,R	5027JJ2007B	312A	RUBBER,SEAT	5040JA3031A
140D	SHELF,NET	5026JJ2001G	314A	STOPPER,COMP	4620JA3009A
140E	SHELF,NET	5026JJ2001H	315A	COMP BASE ASSEMBLY,STD	3103JJ1001J
142D	SHELF,NET	5026JJ2001L	317A	DRIER ASSEMBLY	5851JJ2002B
142E	SHELF,NET	5026JJ2001M	318A	HOLDER,DRIER	4930JJ3002A
143E	SHELF ASSEMBLY,R	5027JJ1008B	319A	TRAY,DRIP	3390JJ0003A
143F	SHELF ASSEMBLY,R	5027JJ1008D	319C	GUIDE,FAN	4974JJ1009A
145A	HOLDER,SHELF	4930JJ2003A	323B	CONDENSER ASSEMBLY,WIRE	5403JJ1007A
145B	HOLDER,SHELF	4930JJ2004A	327A	CAP,DRAIN PIPE	5006JA3034A
145D	GUIDE,RAIL	4974JJ1012A	328A	RUBBER,DAMPING	4J03020A
145G	GUIDE ASSEMBLY,RAIL	4975JJ2005H	328B	RUBBER,DAMPING	4J04328A
147A	BANK,DAIRY	5074JJ1005A	328B	RUBBER,DAMPING	4J04328A
151A	TRAY ASSEMBLY,VEGETABLE	3391JJ1019E	329A	FAN ASSEMBLY	5901JJ1005A
151C	KNOB,SHUTTER	4940JJ2003B	329C	FAN ASSEMBLY	5901JJ1004B
154A	COVER,T/V	3550JJ1033A	332A	GRILLE ASSEMBLY,FAN	3531JJ1004A
155B	SUPPORTER ASSEMBLY,COVER-T/V	4981JJ2001A	401A	CONTROLLER ASSEMBLY(CIRC)	6615JB2005C
158A	COVER,LAMP	3550JJ1040A	404A	MOTOR(MECH),FAN	4680JK1002B
158E	COVER,LAMP	3550JJ1051A	405A	BRACKET ASSEMBLY,MOTOR	4811JJ2002B
160B	DECO,TRAY	3806JL2005D	405B	BRACKET,MOTOR	4810JA3007A
161A	COVER,TRAY	3550JJ2026A	405C	RUBBER,MOTOR-N	J756-00008B
167B	GLASS,SHELF	4890JL1002K	406B	SWITCH,[PUSH]	6600JB1004A
168A	COVER,MAGIC ROOM	3550JJ1035A	409B	LAMP,[INCANDESCENT]	6912JK2002C
170A	TRAY ASSEMBLY,MEAT	3391JJ2004H	409D	REFLECTOR,LAMP	3034JJ1002B
200A	DOOR ASSEMBLY,F	3581JJ8019B	410A	SOCKET ASSEMBLY,LAMP	6621JK2002D
201A	DOOR FOAM ASSEMBLY,F	5433JJ0018C	410G	CAPACITOR,DRAWING	0CZZJB2003H
203A	GASKET ASSEMBLY,DOOR	4987JJ1004A	411A	POWER CORD ASSEMBLY	6411JK1006A
205A	BASKET,DOOR	5004JJ1042B	418A	HEATER,SHEATH	5300JB1100J
205B	BASKET,TILT	5004JJ2005B	420A	MOTOR(MECH),COOLING	4680JK1001B
205C	BASKET,TILT	5004JJ2005A	501A	PWB(PCB) ASSEMBLY,MAIN	6871JB1215A
212A	HANDLE,F	3650JJ1017K	501F	COVER,PWB	3550JJ1042B
212G	NAME PLATE,P(H)	4140JD2001C	503C	PWB(PCB) ASSEMBLY,DISPLAY	6871JB2047A
230A	DOOR ASSEMBLY,R	3581JJ8024B	503D	CASE,DISPLAY	3110JJ1005A
231A	DOOR FOAM ASSEMBLY,R	5433JJ0019B	503E	COVER,DISPLAY	3550JJ2031A
233A	GASKET ASSEMBLY,DOOR	4987JJ1004B	503G	DECO,CONTROL	3806JL1009A
237A	GUIDE,BOTTLE	4974JJ2021A	602A	HOLDER,BRACKET	4930JA3037A
237C	GUIDE,DRAWER	4974JJ1021A	607A	HOLDER,BRACKET	4930JJ2013A
241A	COVER,TRAY	3550JL2003H	610A	COVER,SENSOR	3550JJ2020A
241B	BASKET,DOOR	5004JJ1021A	619B	COVER,VALVE	3550JJ2024A
241C	BASKET,DOOR	5004JJ1031A	621A	CONNECTOR (MECH),DOOR	4932JJ2001B
241D	BASKET,DOOR	5004JJ0001A	623H	COVER,TUBE	3550JJ2036A
241E	BASKET,DOOR	5004JJ1029A	700B	HANDLE ASSEMBLY,F	3651JJ0002D
243A	STOPPER,DOOR	4620JJ3006A	700C	HANDLE ASSEMBLY,R	3651JJ1017H
244A	HANDLE,R	3650JJ2008R	903A	COVER,LOWER	3550JJ0006A
244B	HOLDER,HANDLE	4930JJ2009E	903B	HOLDER,COVER LOWER	4930JJ2021A
244C	HOLDER,HANDLE	4930JJ2010E	903D	SENSOR	6500JK1003A
244D	HOLDER,HANDLE	4930JJ2012E	903E	SENSOR	6500JK1004A
244K	HOLDER,HANDLE	4930JJ2011E	B01	SCREW,DRAWING	1STZJA3004F
248E	DECO,TRAY	3806JJ2035A	S01	SCREW,DRAWING	1SZZJJ3010A
248F	SUPPORTER,HOLDER	4980JJ2005A	S07	SCREW,DRAWING	4000W4A003A
248N	RAIL ASSEMBLY,SLIDE	5219JJ2002A	S22	SCREW,DRAWING	3J05696C
248P	RAIL ASSEMBLY,SLIDE	5219JJ2002B	S24	SCREW,DRAWING	1SZZJA3011B
249G	GUIDE,RAIL	4974JJ1011A	S28	SCREW,DRAWING	3J05696W
281A	COVER,HINGE	3550JJ2013A	S38	SCREW,DRAWING	4J00415D
281B	HINGE ASSEMBLY,U	4775JJ2003B			

LOC	DESCRIPCION	NO. DE PARTE	LOC	DESCRIPCION	NO. DE PARTE
103A	HANDLE,BACK	3650JJ2003E	282B	HINGE ASSEMBLY,C	4775JJ8002A
103B	HANDLE,BACK	3650JJ2003A	282E	CAP,HINGE	5006JJ2001A
103C	COVER ASSEMBLY,LOWER	3551JJ1015B	282F	DECO,DUCT	3806JL2006E
103E	RAIL,SLIDE	5218JJ3001A	282H	CAP,HINGE	5006JJ3004A
105A	DRAIN ASSEMBLY,PIPE-Z	5251JA3003B	283B	HINGE,L	4774JJ3001A
105F	SKIRT,LOWER	5070JJ3002A	284D	SCREW,DRAWING	1STZJA3004K
106A	LEG ASSEMBLY,ADJUST	4779JJ2001A	285A	GUIDE ASSEMBLY,RAIL	4975JJ2007G
106B	WASHER, DRAWING	4J00382C	286A	BUSH	4984JJ3003A
120B	DUCT ASSEMBLY,MULTI	5209JJ1002A	286A	BUSH	4984JJ3003A
125A	TRAY ASSEMBLY,ICE	3391JJ1009B	301A	EVAPORATOR ASSEMBLY	5421JJ1001B
125D	HOLDER,BRACKET	4930JJ3007A	304A	COVER ASSEMBLY,BACK-M/C	3551JJ2008B
128A	GUIDE ASSEMBLY,RAIL	4975JJ2002A	305B	ROLLER	4580JJ3001A
128B	GUIDE ASSEMBLY,RAIL	4975JJ2002B	305B	ROLLER	4580JJ3001A
131A	BANK ASSEMBLY,ICE	5075JJ1001B	305C	PIN,DRAWING	4J04238A
135C	COVER,GRILLE FAN	3550JJ2030A	305C	PIN,DRAWING	4J04238A
136A	TRAY ASSEMBLY,DRAWER	3391JJ1011B	307A	COMPRESSOR,SET ASSEMBLY	2521C-A5725
136B	TRAY,DRAWER	3390JJ1087A	308A	P.T.C ASSEMBLY	6748C-0004D
136F	TRAY ASSEMBLY,DRAWER	3391JJ1033B	309A	O.L.P	6750CR0004S
140B	SHELF ASSEMBLY,R	5027JJ2007B	310A	COVER,P.T.C	3550JA2042A
140D	SHELF,NET	5026JJ2001G	312A	RUBBER,SEAT	5040JA3031A
140E	SHELF,NET	5026JJ2001H	314A	STOPPER,COMP	4620JA3009A
142D	SHELF,NET	5026JJ2001L	315A	COMP BASE ASSEMBLY,STD	3103JJ1001J
142E	SHELF,NET	5026JJ2001M	317A	DRIER ASSEMBLY	5851JJ2002B
143E	SHELF ASSEMBLY,R	5027JJ1008B	318A	HOLDER,DRIER	4930JJ3002A
143F	SHELF ASSEMBLY,R	5027JJ1008D	319A	TRAY,DRIP	3390JJ0003A
145A	HOLDER,SHELF	4930JJ2003A	319C	GUIDE,FAN	4974JJ1009A
145B	HOLDER,SHELF	4930JJ2004A	323B	CONDENSER ASSEMBLY,WIRE	5403JJ1007A
145D	GUIDE,RAIL	4974JJ1012A	327A	CAP,DRAIN PIPE	5006JA3034A
145G	GUIDE ASSEMBLY,RAIL	4975JJ2005H	328A	RUBBER,DAMPING	4J03020A
146A	CAN STORAGE,LOWER	5047JJ1001A	328B	RUBBER,DAMPING	4J04328A
147A	BANK,DAIRY	5074JJ1005A	329A	FAN ASSEMBLY	5901JJ1005A
151A	TRAY ASSEMBLY,VEGETABLE	3391JJ1020C	329C	FAN ASSEMBLY	5901JJ1004B
151C	KNOB,SHUTTER	4940JJ2003B	332A	GRILLE ASSEMBLY,FAN	3531JJ1004A
154A	COVER,T/V	3550JL1006C	401A	CONTROLLER ASSEMBLY(CIRC)	6615JB2005C
155B	SUPPORTER ASSEMBLY,COVER-TA	4081JJ2001B	404A	MOTOR(MECH),FAN	4680JK1002B
158A	COVER,LAMP	3550JJ1040A	405A	BRACKET ASSEMBLY,MOTOR	4811JJ2002B
158E	COVER,LAMP	3550JJ1051A	405B	BRACKET,MOTOR	4810JA3007A
167B	GLASS,SHELF	4890JL1002H	405C	RUBBER,MOTOR-N	J756-00008B
170A	TRAY ASSEMBLY,MEAT	3391JJ2004H	406B	SWITCH,[PUSH]	6600JB1004A
200A	DOOR ASSEMBLY,F	3581JJ8019B	409B	LAMP,[INCANDESCENT]	6912JK2002C
201A	DOOR FOAM ASSEMBLY,F	5433JJ0018C	409D	REFLECTOR,LAMP	3034JJ1002B
203A	GASKET ASSEMBLY,DOOR	4987JJ1004A	410A	SOCKET ASSEMBLY,LAMP	6621JK2002D
205A	BASKET,DOOR	5004JJ1042B	410G	CAPACITOR,DRAWING	0CZZJB2003H
205B	BASKET,TILT	5004JJ2005B	411A	POWER CORD ASSEMBLY	6411JK1006A
205C	BASKET,TILT	5004JJ2005A	418A	HEATER,SHEATH	5300JB1100J
212A	HANDLE,F	3650JJ1017K	420A	MOTOR(MECH),COOLING	4680JK1001B
212G	NAME PLATE,P(H)	4140JD2001C	501A	PWB(PCB) ASSEMBLY,MAIN	6871JB1215A
230A	DOOR ASSEMBLY,R	3581JJ8024B	501F	COVER,PWB	3550JJ1042B
231A	DOOR FOAM ASSEMBLY,R	5433JJ0019B	503C	PWB(PCB) ASSEMBLY,DISPLAY	6871JB2047A
233A	GASKET ASSEMBLY,DOOR	4987JJ1004B	503D	CASE,DISPLAY	3110JJ1005A
237A	GUIDE,BOTTLE	4974JJ2021A	503E	COVER,DISPLAY	3550JJ2031A
237C	GUIDE,DRAWER	4974JJ1021A	503G	DECO,CONTROL	3806JL1009A
241A	COVER,TRAY	3550JL2003H	602A	HOLDER,BRACKET	4930JA3037A
241B	BASKET,DOOR	5004JJ1021A	607A	HOLDER,BRACKET	4930JJ2013A
241C	BASKET,DOOR	5004JJ1031A	610A	COVER,SENSOR	3550JJ2020A
241D	BASKET,DOOR	5004JJ0001A	619B	COVER,VALVE	3550JJ2024A
241E	BASKET,DOOR	5004JJ1029A	621A	CONNECTOR (MECH),DOOR	4932JJ2001B
243A	STOPPER,DOOR	4620JJ3006A	623H	COVER,TUBE	3550JJ2036A
244A	HANDLE,R	3650JJ2008R	700B	HANDLE ASSEMBLY,F	3651JJ0002D
244B	HOLDER,HANDLE	4930JJ2009E	700C	HANDLE ASSEMBLY,R	3651JJ1017H
244C	HOLDER,HANDLE	4930JJ2010E	903A	COVER,LOWER	3550JJ0006A
244D	HOLDER,HANDLE	4930JJ2012E	903B	HOLDER,COVER LOWER	4930JJ2021A
244K	HOLDER,HANDLE	4930JJ2011E	903D	SENSOR	6500JK1003A
248E	DECO,TRAY	3806JJ2035A	903E	SENSOR	6500JK1004A
248F	SUPPORTER,HOLDER	4980JJ2005A	B01	SCREW,DRAWING	1STZJA3004F
248N	RAIL ASSEMBLY,SLIDE	5219JJ2002A	S01	SCREW,DRAWING	1SZJJ3010A
248P	RAIL ASSEMBLY,SLIDE	5219JJ2002B	S07	SCREW,DRAWING	4000W4A003A
249G	GUIDE,RAIL	4974JJ1011A	S22	SCREW,DRAWING	3J05696C
281A	COVER,HINGE	3550JJ2013A	S24	SCREW,DRAWING	1SZZJA3011B
281B	HINGE ASSEMBLY,U	4775JJ2003B	S28	SCREW,DRAWING	3J05696W
281C	HINGE ASSEMBLY,L	4775JJ2008A	S38	SCREW,DRAWING	4J00415D



P/No. 3828JL8087A

17 November, 2005