

This Owner's Manual is provided and hosted by [Appliance Factory Parts](#).

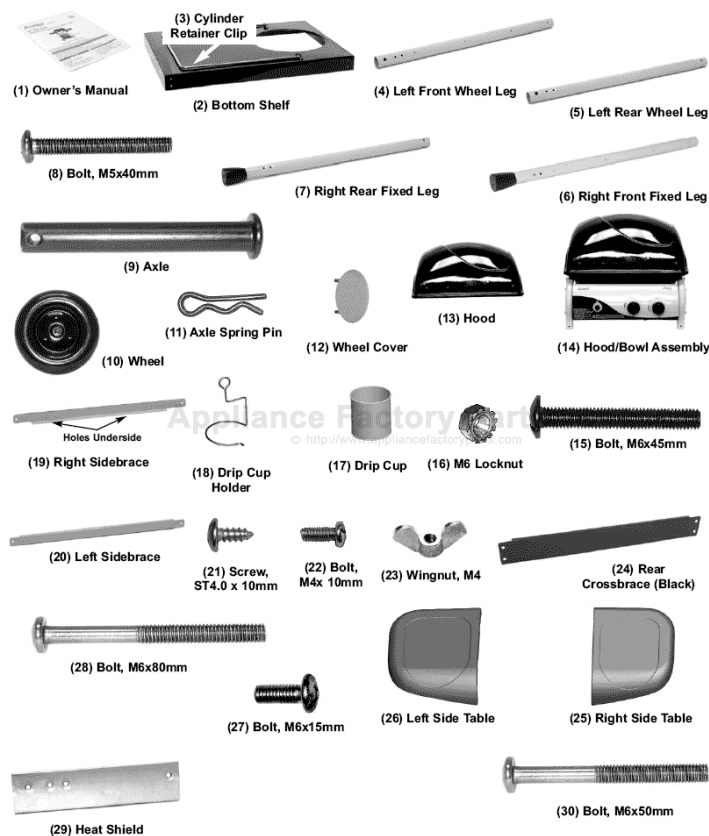

Aussie 7110.7.641 Owner's Manual

[Shop genuine replacement parts for Aussie 7110.7.641](#)



[Find Your Aussie Grill Parts - Select From 122 Models](#)

----- Manual continues below -----

Aussie[®] by Meco[®]



LP Gas Grill Assembly and Use Manual



Joey[™]

MODEL 7110.7.641 Liquid Propane Gas Grill

FOR OUTDOOR HOUSEHOLD USE ONLY. NOT FOR COMMERCIAL USE.

For Customer Service, call 1-800-251-7558 or visit our web site at www.meco.net

⚠ WARNING

- Failure to follow these instructions could result in fire or explosion which could cause death, serious personal injury, or property damage.
- Read and follow instructions carefully before assembly or use.
- **Do not** use this product for any other purpose than which it is intended.
- These instructions must be kept with the user. **SAVE THESE INSTRUCTIONS.**

⚠ DANGER

If you smell gas:

1. Shut off gas to the appliance.
2. Extinguish any open flame.
3. Open lid.
4. If odor continues, keep away from the appliance and immediately call your gas supplier or your fire department.

⚠ WARNING

1. Do not store or use gasoline or other flammable vapors and liquids in the vicinity of this or any other appliance.
2. An LP cylinder not connected for use shall not be stored in the vicinity of this or any other appliance.

— NOTICE —

MECO CORPORATION STRIVES TO BE A QUALITY SUPPLIER OF CONSUMER PRODUCTS. IF WE OMITTED ANY PARTS NEEDED FOR ASSEMBLY, OR YOU NEED TROUBLESHOOTING INFORMATION, PLEASE CONTACT US USING OUR TOLL FREE NUMBER. THANK YOU FOR PURCHASING A MECO CORPORATION PRODUCT.

1-(800)-251-7558
 8 am - 5 pm E.S.T Mon. - Fri.
 1-(423)-639-1171 (TELEPHONE)
 1-(423)-639-2570 (FAX)

www.aussiegrill.net

CONSUMER SERVICE DEPARTMENT
 MECO CORPORATION
 1500 INDUSTRIAL ROAD
 GREENEVILLE, TN. 37745 USA

CONTENTS

<p>I. Assembly Instructions.....2 Parts Illustrations.....3 Step 1) Cart Assembly.....5 Step 2) Assemble Axle, Wheels, & Wheel Covers.....6 Step 3) Assemble Hood/Bowl to Cart.....7 Step 4) Install Drip Cup.....7 Step 5) Assemble Sidebraces8 Step 6) Assemble Side Tables.....9 Step 7) Attach Hood Handle.....9 Step 8) Attach Front Panel.....10 Step 9) Install Flame Diffuser.....10 Step 12) Install Warming Rack and Cooking Grid.....10 II. Operating Your LP Gas Grill.....11 A) Connecting/Disconnecting the Gas.....11 1) Using Gas.....11 2) LP Gas Cylinder.....11 3) LP Hose & Regulator.....11 a) Connecting LP Gas Cylinder.....12 b) Disconnecting LP Gas Cylinder.....12 B) Before Using Your Gas Grill.....12</p>	<p>1) Installation Codes.....12 2) Selecting a Location.....13 3) Performing a Leak Test.....13 4) Lighting the Grill Using the Ignitor.....14 5) Manual Lighting the Grill.....15 6) Check your Flame.....15 C. Grill Cooking.....15 1) Warming Rack.....16 2) Roasting Cooking.....16 3) Operating the Gas Grill.....16 4) End of Cooking Session.....16 III. Care and Maintenance.....17 A) Cleaning the Grill.....17 B) Storage.....18 VI. Troubleshooting.....19 VII. Important Notice-LP Cylinder with OPD.....21 VIII. Limited Warranty.....22</p>
--	---

⚠ DANGER



CARBON MONOXIDE HAZARD

This appliance can produce carbon monoxide which has no odor.

Using it in an enclosed space can kill you.

Never use this appliance in an enclosed space, such as a camper, tent, car or home.

ASSEMBLY INSTRUCTIONS

⚠ WARNING

To reduce the risk of serious bodily injury or death:

- The use of alcohol, prescription or non-prescription drugs could impair the consumer's ability to properly assemble or safely operate this appliance.
- Do not connect LP cylinders until assembly is complete.

PREPARATION FOR ASSEMBLY: Remove Grill and all the packaging from carton and place on floor. Make sure there are no loose parts. **Note: Before using your grill, read the instructions and your manual.** For easier set-up and assembly, follow instructions of each step in the order they are written as you look at the diagrams. If accessories mentioned in certain assembly steps do not come with your model, skip that step and proceed to the next step that applies to your model.

PARTS ILLUSTRATIONS

If you need replacement parts, refer to the Parts Illustrations and the Parts List to find the exact parts you need. If you have any questions which require help, contact Customer Service and be sure to mention the model number of your grill.



(1) Owner's Manual



(3) Cylinder Retainer Clip

(2) Bottom Shelf



(4) Left Front Wheel Leg



(5) Left Rear Wheel Leg



(8) Bolt, M5x40mm



(7) Right Rear Fixed Leg



(6) Right Front Fixed Leg



(9) Axle



(10) Wheel



(11) Axle Spring Pin



(12) Wheel Cover



(13) Hood



(14) Hood/Bowl Assembly



Holes Underside

(19) Right Sidebrace



(18) Drip Cup Holder



(17) Drip Cup



(16) M6 Locknut



(15) Bolt, M6x45mm



(20) Left Sidebrace



(21) Screw, ST4.0 x 10mm



(22) Bolt, M4x 10mm



(23) Wingnut, M4



(24) Rear Crossbrace (Black)



(28) Bolt, M6x80mm



(27) Bolt, M6x15mm



(26) Left Side Table



(25) Right Side Table



(29) Heat Shield



(30) Bolt, M6x50mm



**(31) Handle Spacer
(Tapered)**



**(32) Handle Spacer
(Fitted)**



(33) Hood Handle

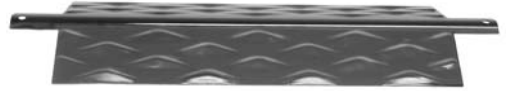

(35) Flame Diffuser



(34) Cooking Grid



(36) Main Burner



**42) Main Burner
Electrode**

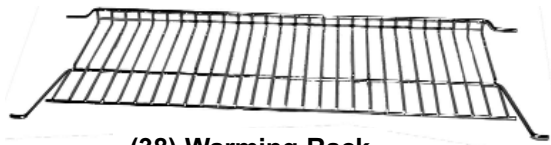

(38) Warming Rack

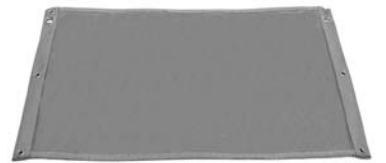

(37) Fabric Panel



(41) Control Knob



**(40) Control Panel
w/Manifold and
Regulator**



**(39) LP Cylinder
Heat Shield**

⚠ CAUTION

To reduce the risk of a cut injury:

- Wear protective gloves when handling parts that have sharp edges.
- Some assembly may require help from another person. Observe where noted.

TOOLS:



STEP 1) Cart Assembly:

Attach the Legs to the Bottom Shelf with M5 x 40 Bolts threaded into the Bottom Shelf holes. Position legs with the holes exactly as indicated .

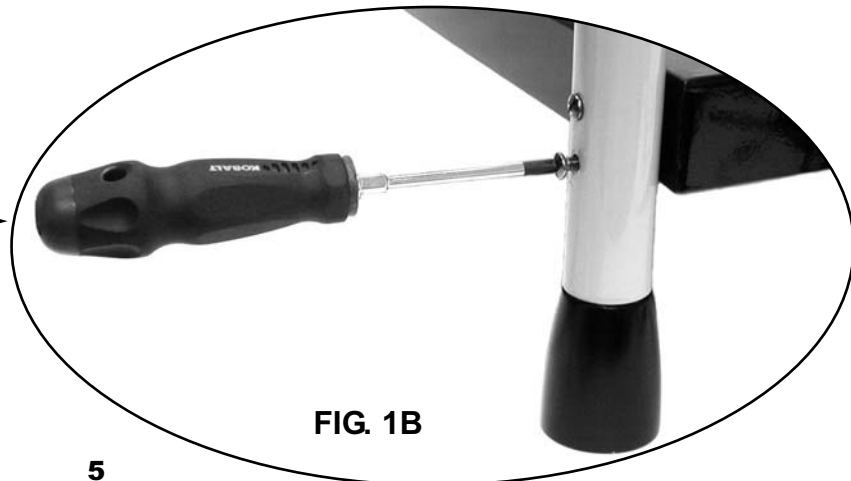
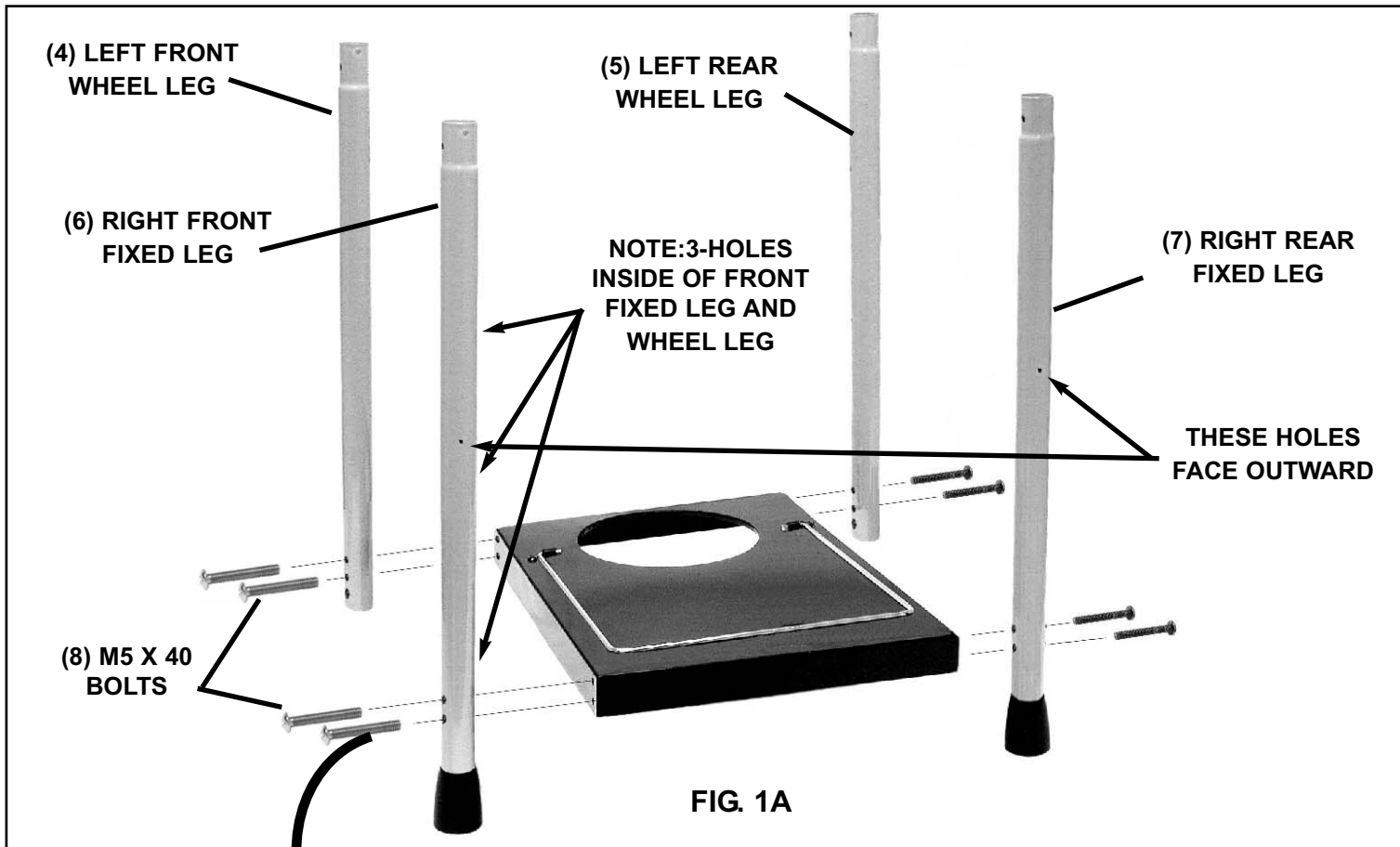

STEP 2) Assemble Axle, Wheels & Wheel Covers:

Push Axle through center hole in Wheel and through lower hole in each leg. (FIG. 2A) Insert Axle pin through small hole in end of Axle until it snaps over it. (FIG. 2B) Align Wheel Cover pins with 3-holes in Wheel and push flush against Wheel.

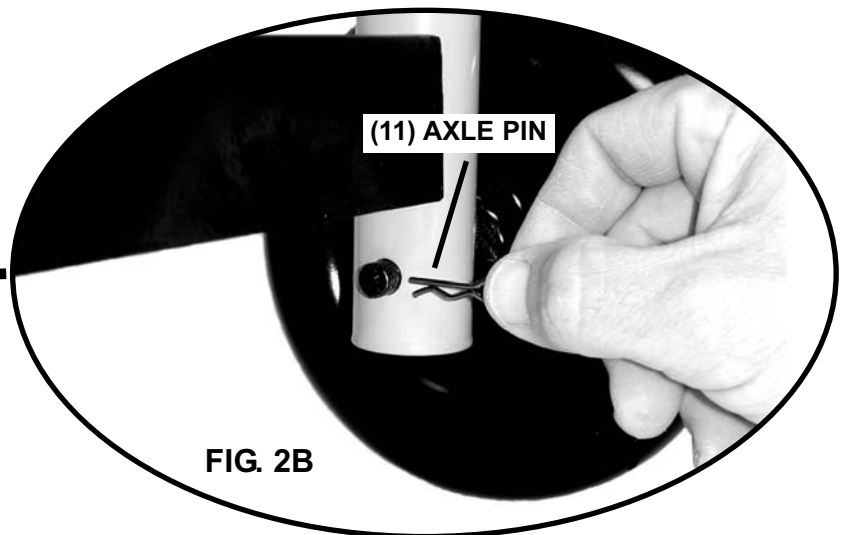
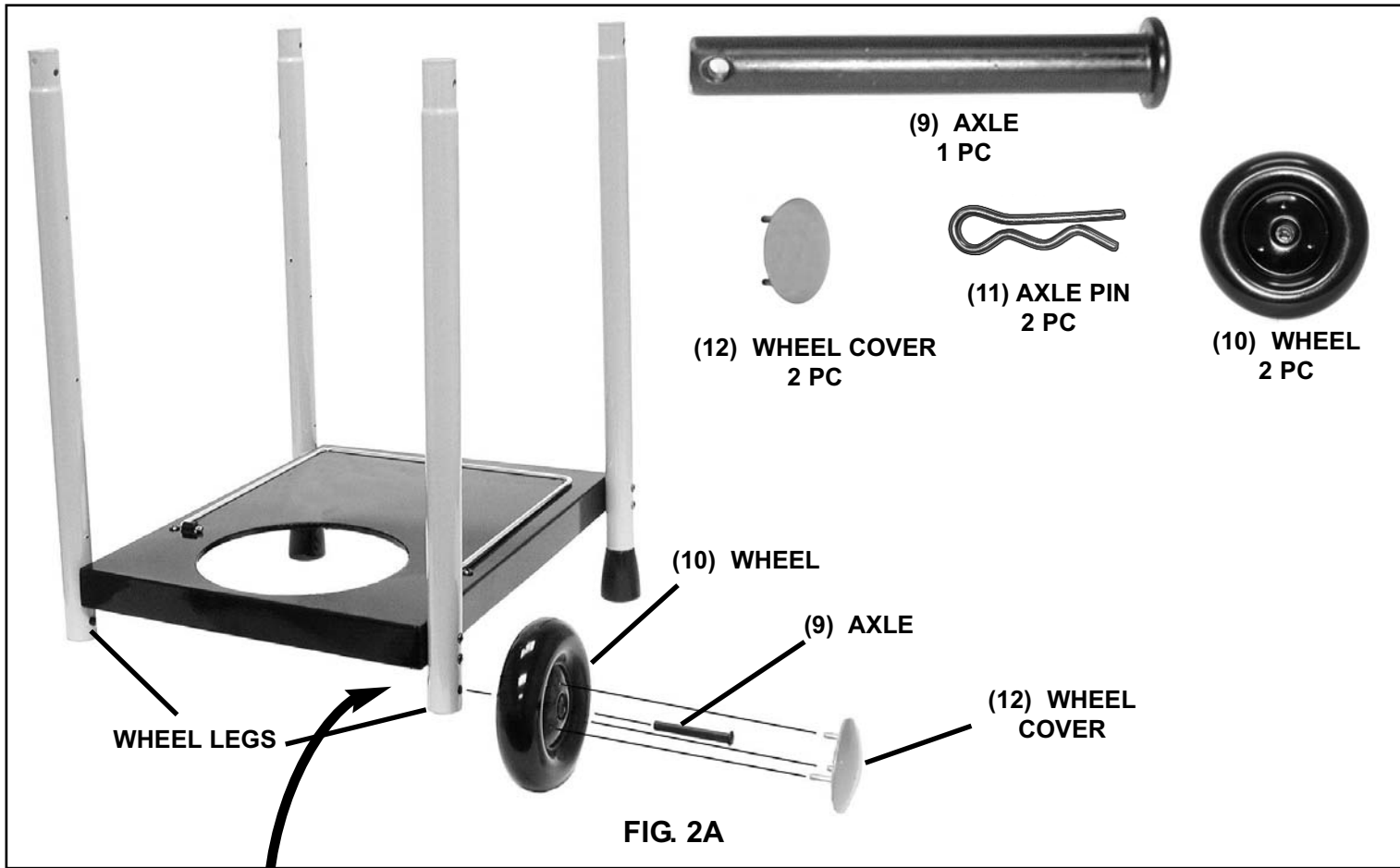

Step 3) Assemble Hood/Bowl to Cart:



(14) HOOD/BOWL ASSEMBLY



(15) BOLT, M6X45
4 PC



(16) M6 LOCKNUT
4 PC

NOTE: REQUIRES 2-PERSONS

- With Cart upright, align Bowl Bracket legs with Cart legs. (FIG. 3A)
- Lower Hood/Bowl so ends of Cart legs insert into Bowl Bracket legs.
- Press downward until leg screw holes align.
NOTE: If cart legs do not align and fit into Bowl Bracket legs easily, loosen the Control Panel bolts slightly. Then open the Hood and loosen the 2-Bowl/Leg bolts on either, or both sides of the Bowl. (FIG. 3B)
- Insert M6x45 Bolts from the outside through the legs and tighten with M6 Locknuts. (FIG. 3C)
- Re-tighten all Bolts.

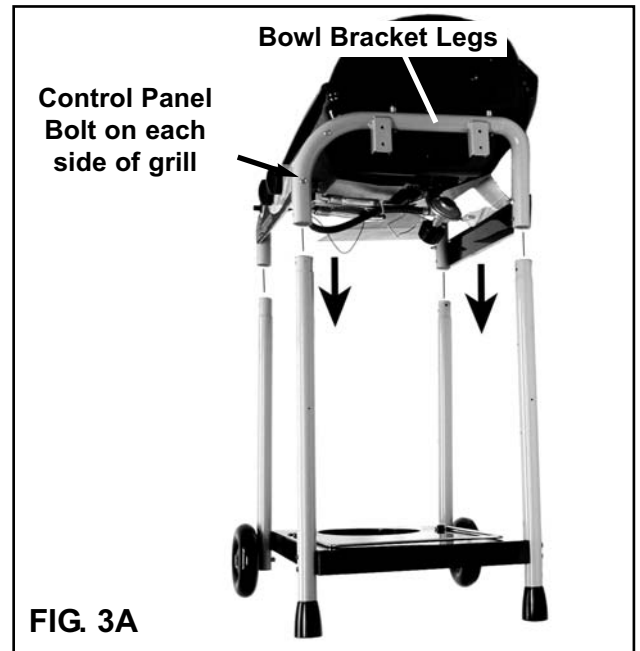

FIG. 3A

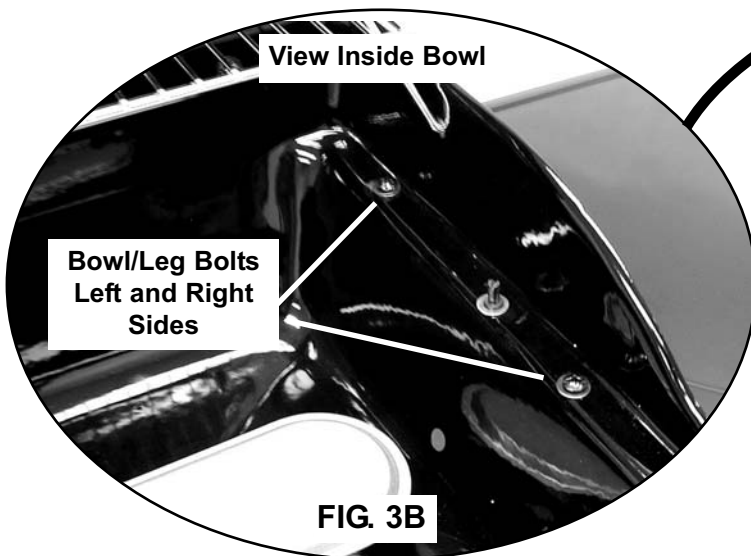

FIG. 3B

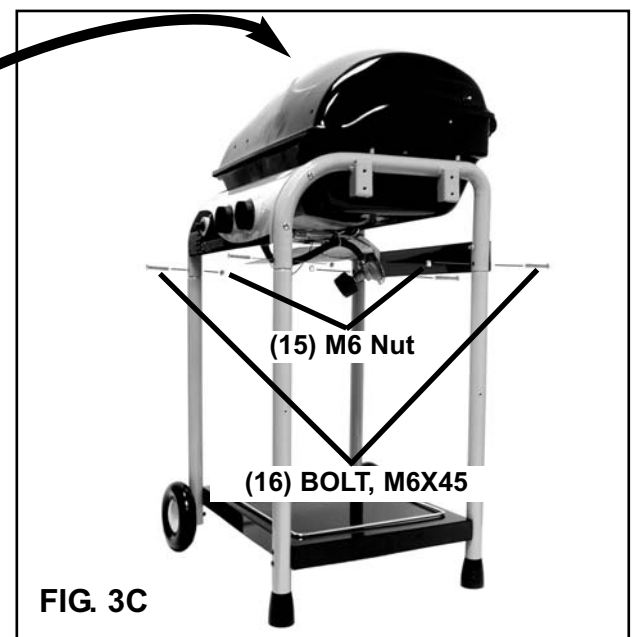

FIG. 3C

Step 4) Install Drip Cup:

Insert Drip Cup into Drip Cup Holder ring (installed in bottom of Grill Body) until the cup flange is flush with the ring



(17) DRIP CUP

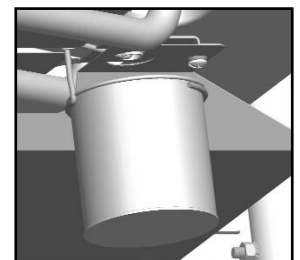

Step 5) Assemble Sidebraces:

- Attach Right and Left Sidebraces (19 & 20) to legs with ST4.0 x 10 Screws. (FIG. 5A) Secure Bottom Heat Shield to Left Sidebrace with M4x10 Bolts and M4 Wingnuts. (FIG. 5B) Allow Heat Shield Edge to overlap Sidebrace edge.

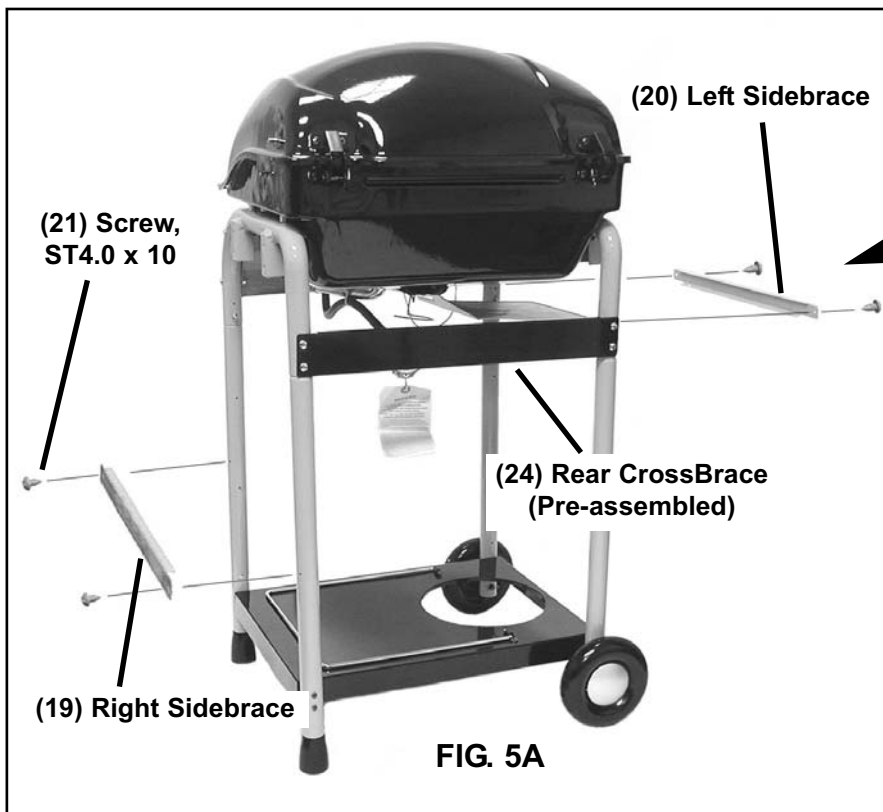
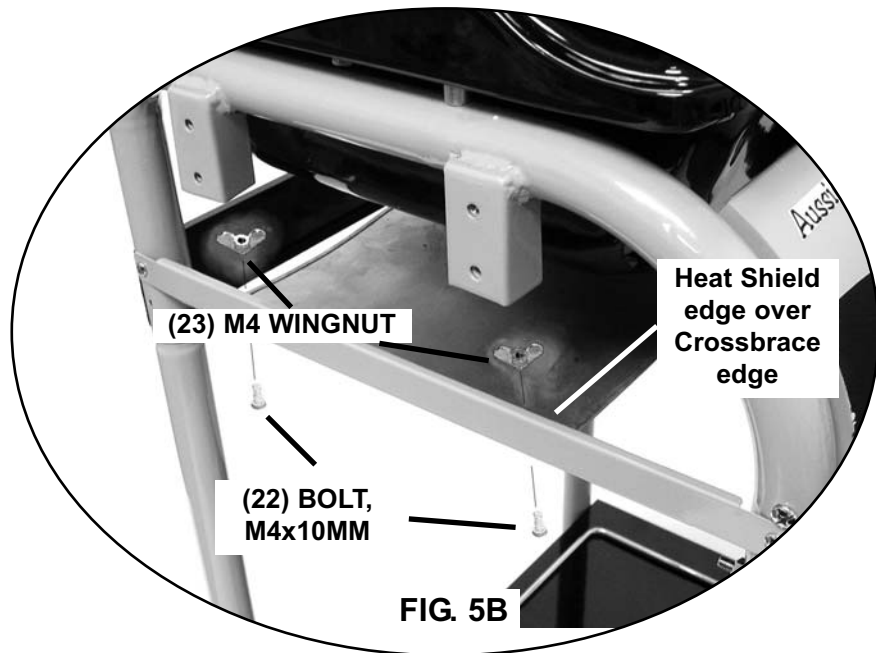

Step 6) Assemble Side Tables:

Align bracket holes of Left and Right Side Tables with holes in Bowl Leg Brackets. Attach Side Tables with M6 x 15 Bolts underneath. (FIG. 6A 7 6B)

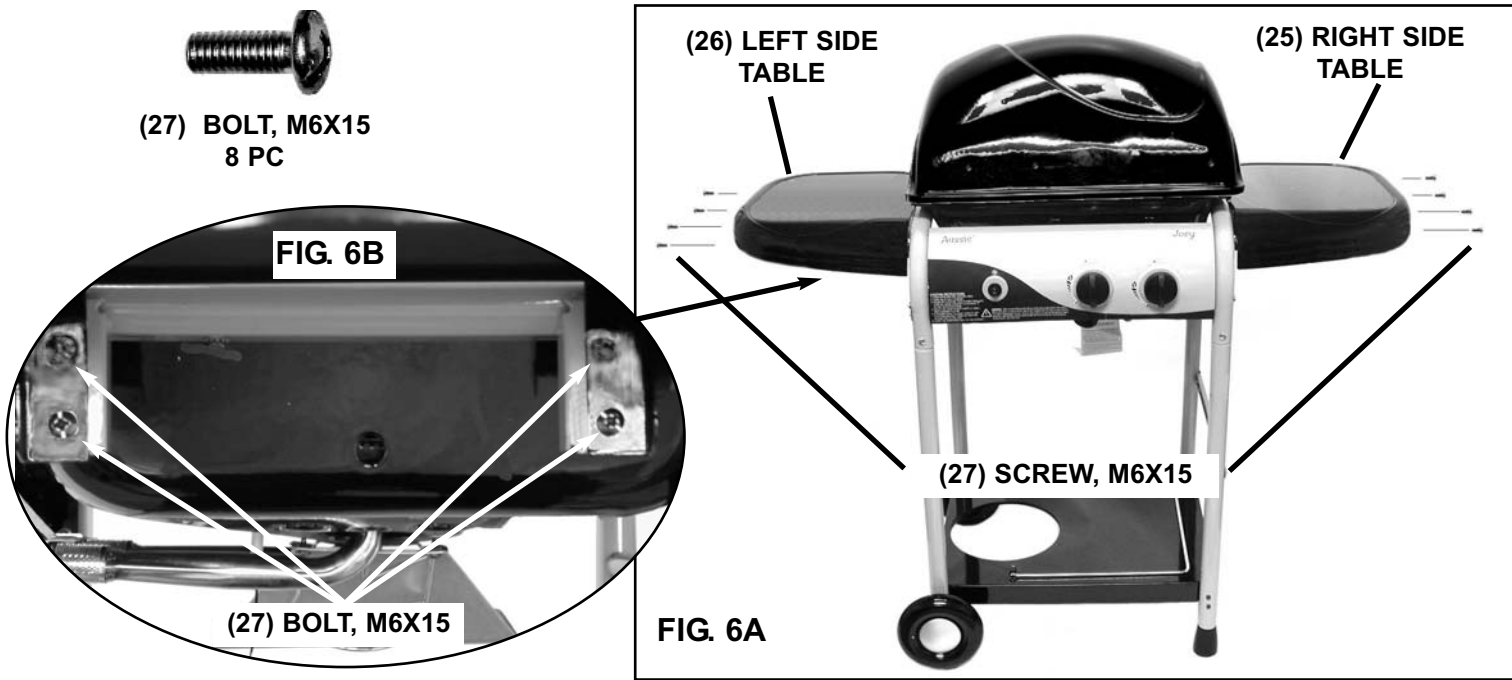

Step 7) Attach Hood Handle:

Open Hood. Insert the M6 x 50 Bolt through the right side of Heat Shield (right side has one hole), Hood and Handle Spacer and thread into handle. Do not tighten completely. Insert the M6 x 80 Bolt through the left side Heat Shield, Hood and Tapered Spacer and thread into handle. Tighten both bolts making sure Spacers fit securely to the Hood and Handle. If installed correctly, the heat shield should not interfere with the cooking grate when hood is closed.

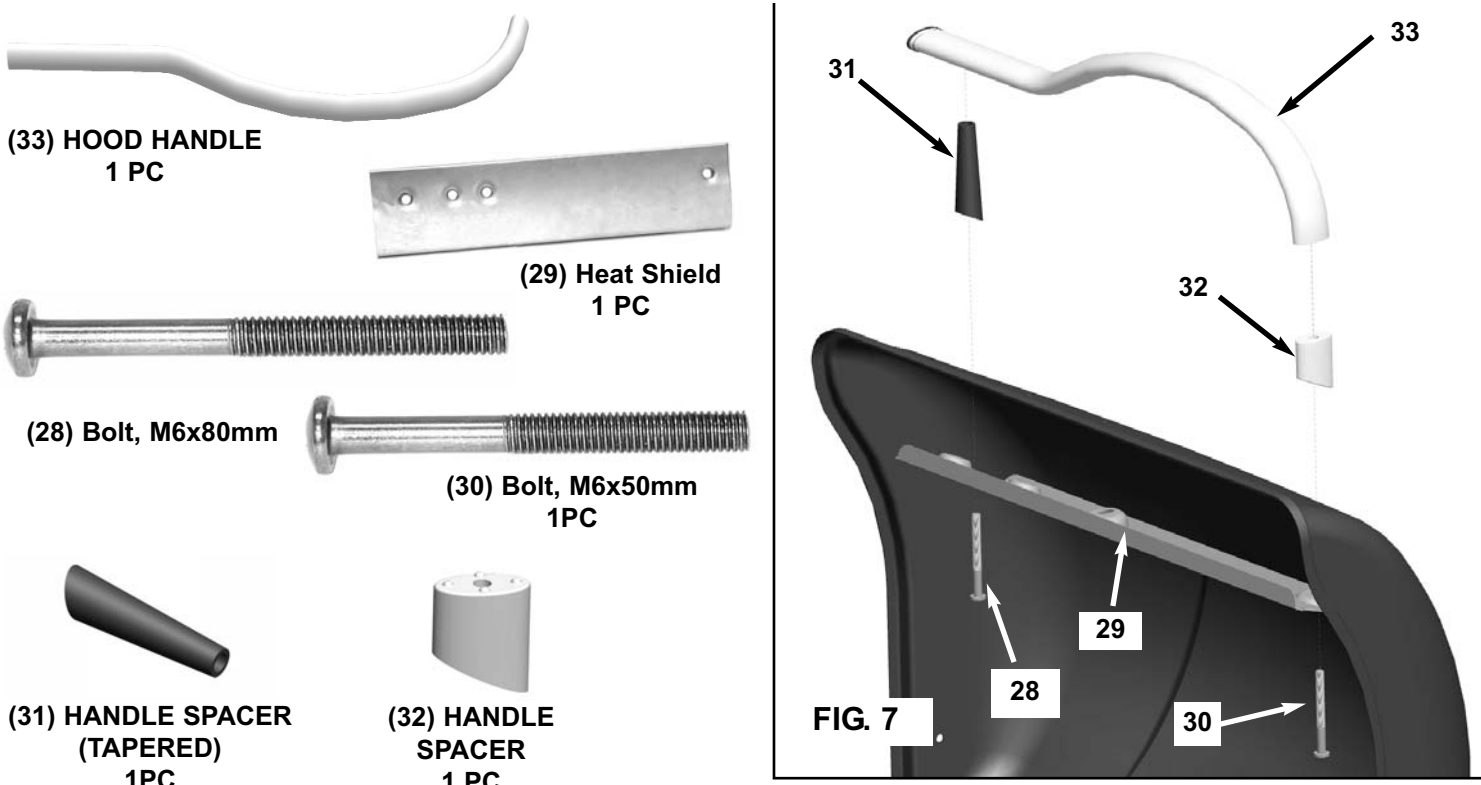

Step 8) Attach Front Panel:

Remove the M6 nut used to attach the upper and lower leg sections. Place the large eyelet over the bolt and replace the nut. (FIG. 8B) Using the ST4.0 Screw, secure the Fabric Panel to holes in the lower legs over the eyelets. (FIG. 8A)

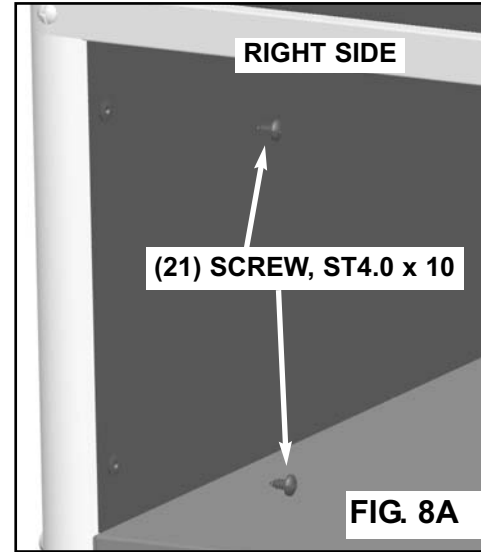
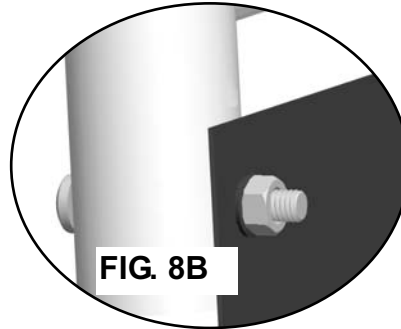

Step 9) Install Flame Diffuser:

Place the Flame Diffuser over the Main Bowl Burner, onto the two mounting studs on each side of the Bowl. (FIG. 9)

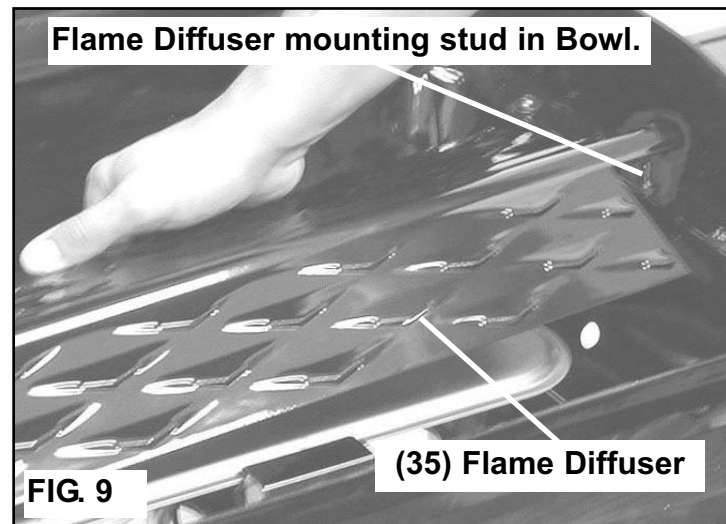
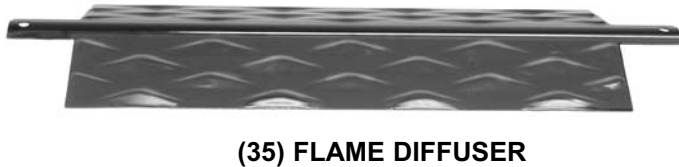

Step 10) Install Cooking Grid:

(Note Warming Rack already installed.)

Lay Cooking Grid onto the Bowl ridges over the Flame Diffuser and Main Burner. (FIG. 10)

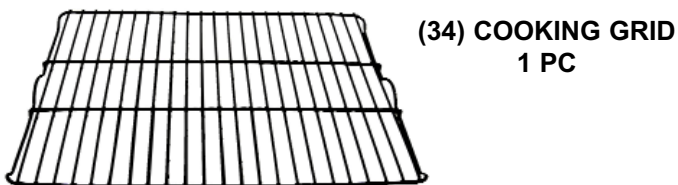

OPERATING YOUR LP GAS GRILL

CONNECTING/DISCONNECTING THE GAS

USING GAS

DANGER

CARBON MONOXIDE HAZARD

- This appliance can produce carbon monoxide which has no odor. Using it in an enclosed space can kill you.
- Never use this appliance indoors, on recreational vehicles, or boats.

WARNING

To reduce the risk of serious bodily injury or death:

- Use only propane gas in this LP gas grill.
- Do not attempt to convert an LP unit to natural gas.
- Any use or alteration of this unit not intended could be unsafe and will void your warranty.
- Always use a gas appliance outdoors in an open area with good ventilation to avoid breathing toxic fumes from leaking gas, explosion or fire. As with all conventional fuels, the burning process consumes oxygen and produces toxic gases, including carbon monoxide. In addition, the combustion products of such fuels, including liquefied petroleum (LP), contain chemicals known to the state of California and other authorities to cause cancer, birth defects and other reproductive harm.

LP GAS CYLINDER

WARNING

To reduce the risk of serious bodily injury, fire or death:

- Read and follow all warnings on LP gas cylinder.
- If you see, smell, or hear the hiss of LP gas escaping from the cylinder:
 1. Do not attempt to light appliance.
 2. Extinguish any open flame.
 3. Disconnect from fuel supply.
- Do not operate the LP gas grill without the LP gas cylinder secured to the cart and oriented as shown in Assembly Instructions for Connecting the LP Cylinder.
- Never connect or disconnect LP gas cylinder or fittings while grill is in use or is hot.
- When the LP gas cylinder is connected, keep the grill outside in a well-ventilated space.
- Do not use an LP gas cylinder if it shows signs of dents, gouges, bulges, fire damage, corrosion, leakage, excessive rust or other forms of visual external damage; it may be hazardous and should be checked by a liquid propane supplier. Do not use an LP cylinder with a damaged valve.
- Do not store a spare LP gas cylinder under or near the LP gas grill.
- When grill is not in use, turn off all grill control knobs, LP cylinder valve and disconnect LP cylinder.

- Never fill the LP gas cylinder more than 80% of cylinder volume. (20 lb. maximum) Do not ask the propane supplier to over-fill the cylinder.
- If you obtain LP gas through a cylinder exchange dealer, make sure you get a safe and adequate O.P.D. cylinder. (See page 22) Use only a licensed LP gas cylinder dealer.
- Place dust cap on cylinder valve outlet whenever the cylinder is not in use. Only install the type of dust cap on the cylinder valve outlet that is provided with the cylinder valve. Other types of caps or plugs may result in leakage of propane.

· The LP gas cylinder, for use with this LP gas grill, must meet the following requirements:

- 1) 12" diameter x 18" tall, 20 lb.. maximum capacity
- 2) Overfill Protection Device (OPD) safety feature (should be noted on cylinder)
- 3) Must be constructed and marked in accordance with Specifications for LP-Gas Cylinders of the U.S. Department of Transportation (DOT) or the National Standard of Canada, CAN\CSA-B339, Cylinders, spheres and Tubes for Transportation of Dangerous Goods; and Commission, as applicable (See collar for marking)
- 4) Must have collar to protect LP cylinder valve.

LP HOSE AND REGULATOR

WARNING

To reduce the risk of serious bodily injury or death:

- Clean and inspect the gas hose/regulator before each use of the outdoor cooking gas appliance. The gas hose/regulator must be replaced prior to being used, if there is evidence of excessive abrasion or wear, or if the hose is cut or leaks.
- Use only the gas hose/regulator assembly that has been supplied with this gas grill. Do not use hose/regulator from another manufacturer.
- Always check for gas leaks when you connect and disconnect the hose/regulator to the LP gas cylinder, especially after a period of storage (for example, over winter).
- Make sure there are no sharp bends in the hose.
- Make sure hose/regulator does not contact any heated surfaces.

· If the hose/regulator assembly is not working properly and you need a replacement, contact the manufacturer (1-800-251-7558). Be sure to specify your grill model.

Connecting the LP Cylinder:

- 1) Fill empty OPD LP Cylinder at your local LP gas supplier.
- 2) Make sure all control knobs and LP Cylinder valve are turned to the "Off" position.

- 3) Lift and swing LP Cylinder Retainer Clip to outside of grill. Set LP cylinder in the large hole inside the Bottom Shelf. Rotate the LP cylinder toward the front of grill so regulator hose may connect. (FIG. 11A)

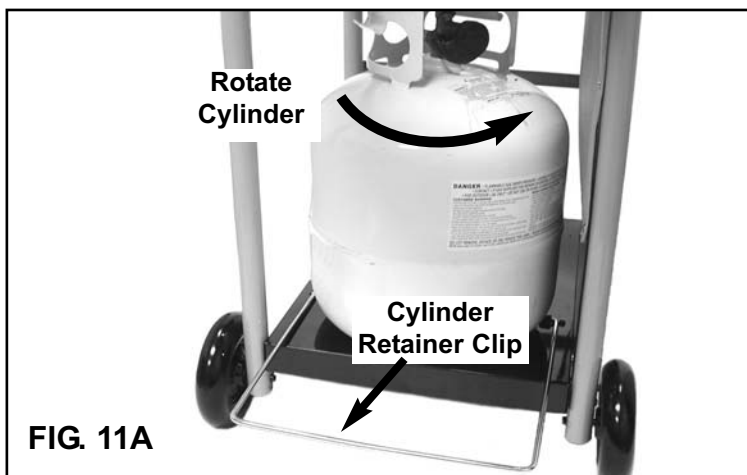

FIG. 11A

- 4) Cut the tie clamp securing the regulator and Hose to the burner tube.

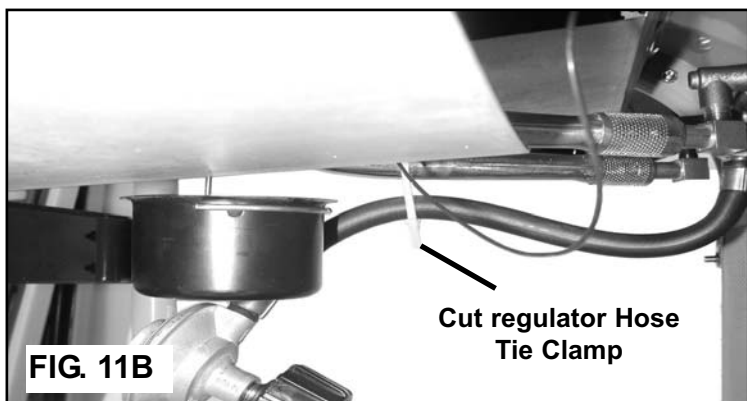

FIG. 11B

- 5) Remove the protective cap from the LP cylinder nozzle. (Save cap for re-capping.) Make sure all control Knobs are turned "OFF". Hold Regulator in a straight line with LP cylinder valve so the connection does not cross thread. Insert Regulator Nipple into the LP cylinder valve. (Fig. 11C) Hand tighten coupling nut in clockwise direction. Do not use tools.

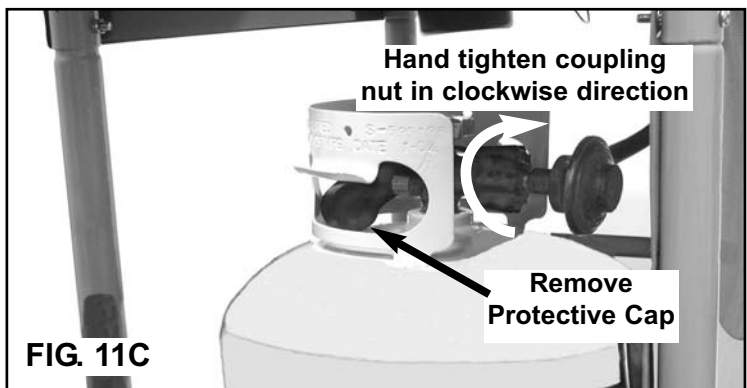

FIG. 11C

CAUTION

To avoid pinching in next step, keep fingers and hands near corners of Cylinder Retainer Clip when swinging Clip over cylinder.

- 6) Swing the Cylinder Retainer Clip over round shoulder of the LP cylinder. Exert pressure at ends of clip until it stops at the cylinder carry handle.

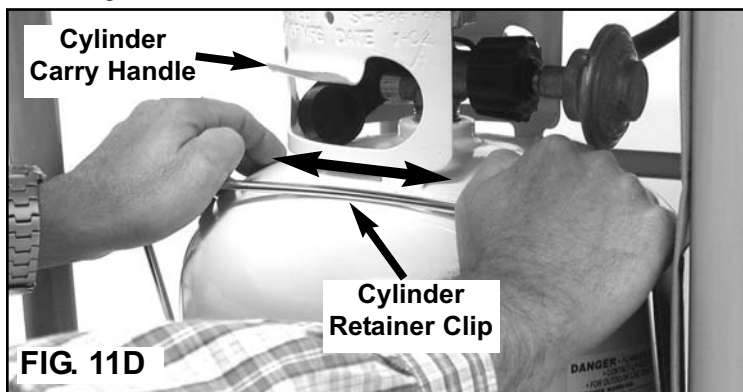

FIG. 11D

Disconnecting LP gas cylinder:

- 1) Turn all control knobs to the "off" position and turn the handle on the LP gas cylinder clockwise until it stops.
- 2) Turn coupling nut on regulator counter-clockwise until regulator is released from the threaded LP cylinder gas nozzle.
- 3) Replace the protective cap over LP cylinder gas nozzle.

BEFORE USING YOUR GAS GRILL

INSTALLATION CODES

WARNING

- To reduce the risk of serious bodily injury or death:
- This installation must conform with local codes or, in the absence of local codes, with either the National Fuel Gas Code, ANSI Z223.1/NFPA 54 Natural Gas and Propane Installation Code, CSA B149.1, or Propane Storage and Handling Code, B149.2 or the Standard for Recreational Vehicles, ANSI A 119.2/NFPA 1192 and CSA Z240 RV Series, recreational Vehicle Code, as applicable.
 - If an external electrical source is utilized, the outdoor cooking appliance, when installed, must be electrically grounded in accordance with local codes or, in the absence of local codes, with the National Electrical Codes, ANSI/NFPA 70, or the Canadian Electrical Code CSA C22.1.
 - Keep any electrical supply cord away from any heated surfaces.

SELECTING A LOCATION

WARNING

To reduce the risk of serious bodily injury or death:

- This outdoor cooking appliance shall be used only outdoors and shall not be used in a building, garage, or any other enclosed area. Locate outdoor cooking appliance in an area with good ventilation on a level stable surface clear of combustible and flammable material.
- Maintain minimum clearances of 36" from back and sides of grill to any combustible construction.
- Do not locate this appliance under overhead unprotected combustible construction.
- This outdoor cooking appliance is not intended to be used in or on boats or installed in or on recreational vehicles.
- Do not use gas grill as a space heater.

PERFORMING A LEAK TEST

WARNING

To reduce the risk of serious bodily injury or death:

- Perform a leak test before each use and each time a gas connection or disconnection is done .
- Perform a leak test in a well ventilated area.
- Never use an open flame to test for gas leaks.
- Never smoke near the grill during a leak test.
- Do not perform a leak test on a grill while it is hot or in use.
- Do not use the gas grill if you detect a gas leak that cannot be corrected by using the leak test procedures.

How to perform a leak test:

Supplies Needed for a Leak Test: Clean paint brush, water, and dish washing liquid.

- 1) Use an LP Cylinder equipped with an OPD (Overfill Prevention Device) and have it filled at an authorized LP gas dealer by a qualified attendant.
- 2) Make sure all of the grill control panel knobs are turned to the "off" position and verify that the LP gas cylinder valve is closed by turning the knob on the LP gas cylinder clockwise until it stops.
- 3) Mix one part of water with one part of dish washing liquid.
- 4) Remove Fabric Panel from the front legs if necessary.
- 5) Open the knob on the LP gas cylinder counter-clockwise. (FIG. 12A)

- 6) Check for leaks by brushing the soap solution on all gas valves, hose connections and fittings. (shown by the heavy arrows in (FIG. 12A & 12B) Make sure you generously brush the locations with the soap solution, completely surrounding the connections and fittings.
- 7) If "growing" bubbles appear on any of the connection points, you have detected a gas leak. Immediately close the LP cylinder valve by turning handle clockwise.
 - A) If leak appears at either end of hose and regulator assembly, retighten the connection at the leak, but do not over tighten. (Note: Only hand tighten at coupling nut) Repeat Leak Test.
 - B) If the leak is coming from the Gas Cylinder, from the valves at the control knobs, or if the leak cannot be stopped, do not use the grill. Call Customer Service at 1-800-251-7558.
- 8) Upon completion of leak test, turn all control knobs to the "off" position. Turn the handle on the LP gas cylinder clockwise until it stops. Disconnect LP gas cylinder by turning coupling nut on regulator in a counter clockwise direction until regulator is released from threaded LP cylinder gas nozzle.
- 9) Place the protective cap over LP cylinder gas nozzle.

After completing Leak Test, you are ready to begin using your grill!

Turn LP Gas Cylinder valve counter-clockwise.

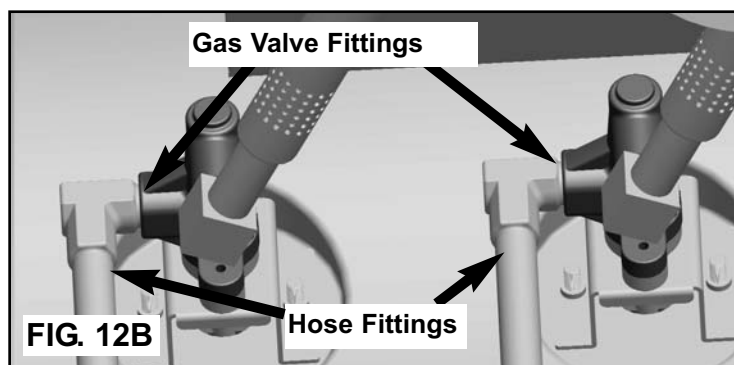

WARNING

To reduce the risk of serious bodily injury or death:

- Open Hood before lighting the grill to prevent an explosion from any gas accumulation.
- If lighting attempts fail, or the burners go out during operation, turn all control knobs “Off” to dissipate any accumulation of gas. Accidental ignition could occur. Wait five minutes before repeating lighting procedure.
- Light both left and right sides of burner to prevent gas from accumulating.

LIGHTING THE GRILL USING THE IGNITOR

1. Open the Hood.
2. Important: Make sure all control knobs are turned “Off”. (FIG. 13A)
3. Turn the LP Gas Cylinder valve open counter clockwise until it stops. (FIG. 13B)
4. Push the left control knob in and turn counter clockwise to the High flame position. (FIG. 13C & 13D)
5. Pause 4 seconds and push the ignitor in several times to light the burner. Listen for the spark ignition and look to make sure the burner is lit. If no spark, see (FIG. 13E) and [Troubleshooting Section](#).
6. From the “Off” position, push right control knob in and turn counterclockwise to the High position. Your grill has a crossover ignition system that allows the burner to light each side successively. Make sure the right side of burner is lit.
7. If either side of burner fails to light, repeat Step 4.

If a burner goes out during operation, turn all knobs to the “Off” position and close the LP cylinder valve to dissipate any accumulated gas. Open hood and wait five minutes before attempting to relight the grill.

If any or all burners fail to light after three or four attempts following Steps 4-6, turn all knobs to the “Off” position and close the LP gas cylinder valve to dissipate any accumulated gas. Wait five minutes; then repeat the lighting procedures. NOTE: If the burner still fails to light, refer to the [Troubleshooting Section](#). The burner can also be lit manually, see [Manual Lighting of the Grill](#).

8. After ignition, turn the control knobs to “High” for 3-5 minutes and close the Hood to preheat the grill. Preheat the grill before every cooking session.

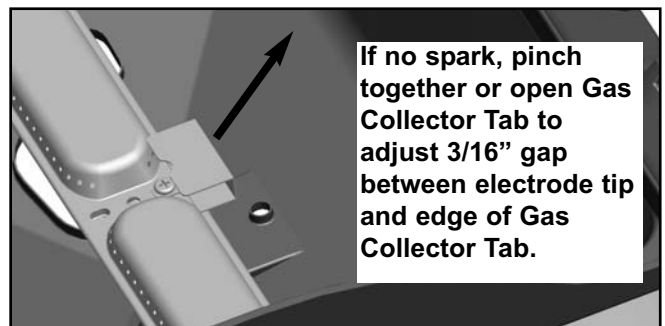
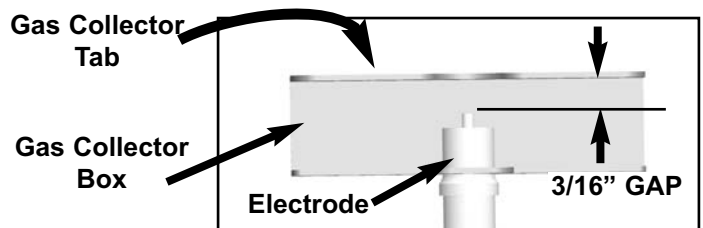
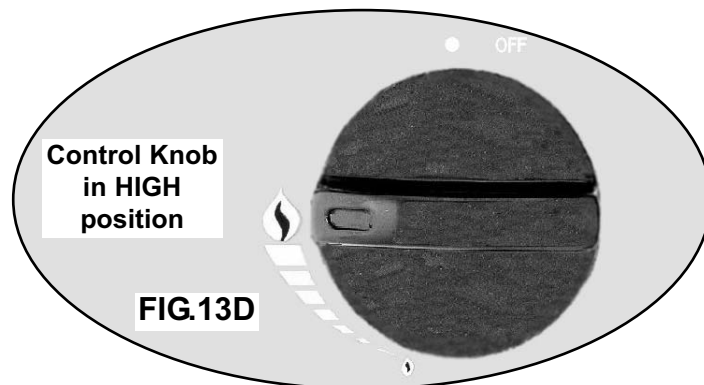
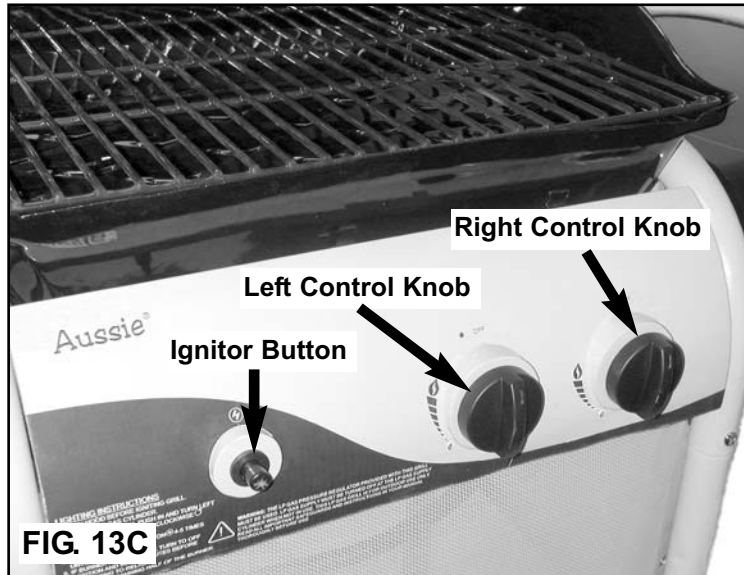
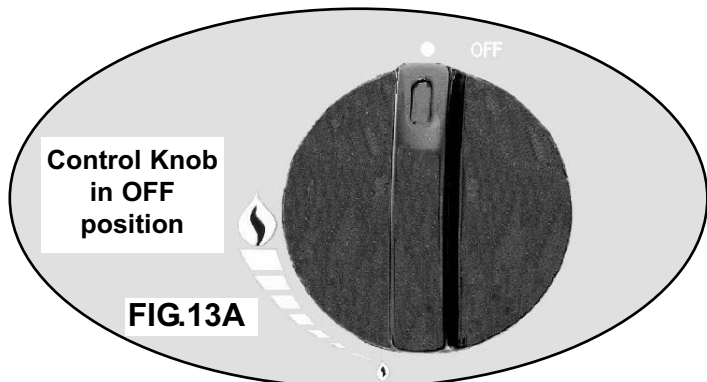

MANUAL LIGHTING THE GRILL

WARNING

To reduce the risk of serious bodily injury or death:

- Open Hood before lighting the grill to prevent an explosion from any gas accumulation.
- If lighting attempts fail, or the burners go out during operation, turn all control knobs “Off” to dissipate any accumulation of gas. Accidental ignition could occur. Wait five minutes before repeating lighting procedure.
- Light both left and right sides of burner to prevent gas from accumulating.
- When reaching under the grill, avoid contact with hot surfaces.

1. Open the Hood.
2. Important: Make sure control knobs are turned “Off”. (See FIG. 13A)
3. Turn the LP Gas Cylinder valve open counter clockwise until it stops. (See FIG. 13B)
4. Insert a lit match through match-lighting hole underneath the grill bowl on the right side. (FIG. 14A) Hold the flame near the burner. (FIG. 14B)
5. Push in and turn the right main burner control knob counterclockwise to the “High” position. (See FIG. 13C & 13D)
6. From the “Off” position, push left control knob in and turn counterclockwise to the High position. Your grill has a crossover ignition system that allows the burner to light each side successively. Make sure the left side of burner is lit.
7. If either side of burner fails to light, repeat Step 4 & 5.

If any or all burners fail to light after three or four attempts following Steps 4-5, turn all knobs to the “Off” position and close the LP gas cylinder valve to dissipate any accumulated gas. Wait five minutes; then repeat the lighting procedures. NOTE: If the burner still fails to light, refer to the [Troubleshooting Section](#).

8. After ignition, turn the control knobs to “High” for 3-5 minutes and close the Hood to preheat the grill. Preheat the grill before every cooking session.

If a burner goes out during operation, turn all knobs to the “Off” position and close the LP cylinder valve to dissipate any accumulated gas. Open hood and wait five minutes before attempting to relight the grill.

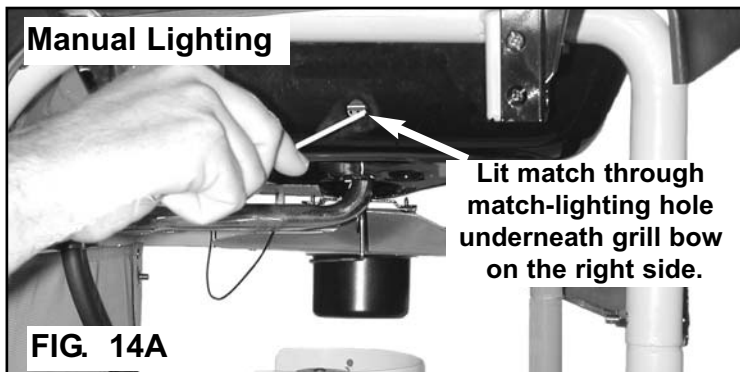

Manual Lighting

Hold flame near Burner.

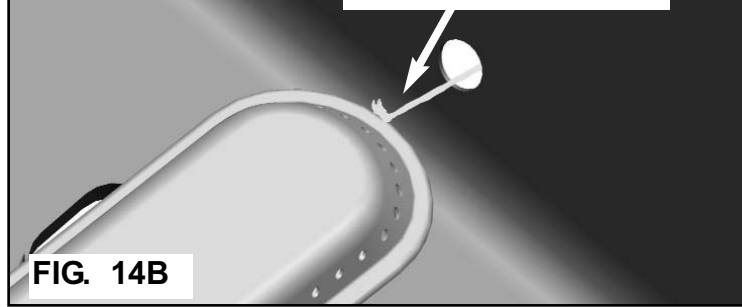

CHECK YOUR FLAME

Your burners have been preset by the manufacturer for optimal flame performance. A blue flame, possibly with a small yellow tip, is the result of the optimal air and gas mixture. (FIG. 15)

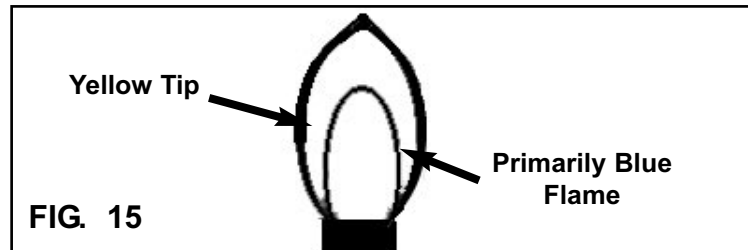

Check the flame before each cooking session and throughout the grilling season. Always check especially after long periods of storing the grill. If the flame is significantly yellow in color, the amount of LP gas in the air/LP gas mixture is not correct. This could be due to a blocked burner from grease drippings or from insects building a nest inside the burner or burner opening. See [How to Clean the Burners](#).

GRILL COOKING

WARNING

To reduce the risk of serious bodily injury, death or grill damage:

- Always make sure the Grease Cup is empty and properly installed in the wire ring under the Bowl before cooking to prevent a grease fire .
- Do not leave any utensils on a hot Cooking Grid or cookware.

Cooking on the Grids: The burners heat up the Flame Diffusers under the Cooking Grids, which in turn heat the food on the grill. The natural food juices from cooking fall onto the hot Flame Diffusers below and vaporize. Rising smoke bastes the food, giving it that unique barbecued flavor.

CAUTION

- Do not preheat grids over 5 minutes. The porcelain coating could be damaged.
- Use only long-handled heat resistant plastic or wooden utensils to avoid scratching the porcelain coating.

WARMING RACK

Warming racks are a convenient way to keep cooked food warm or to warm items such as bread or rolls. When opening the hood, be alert of dripping fat from the warming rack which could then drip onto the barbecue causing a mess. Always check that your warming rack is properly fitted before use.

ROASTING COOKING

WARNING

To avoid burns from the hot air and steam trapped inside:

- Open the hood carefully when grill roasting.

Closing the Hood forms an 'oven' and traps a large amount of heat for roasting whole meats, chickens, etc. Therefore, it is IMPORTANT that the burner is turned to the "Low" position to prevent burning of the food.

To contain juices and fat, place the food to bake or roast in a metal baking tray. Monitor the cooking temperature and time with a meat thermometer. Avoid lifting the hood frequently as heat is lost each time.

OPERATING THE GAS GRILL

WARNING

To reduce the risk of serious bodily injury or death:

- Never use charcoal in your gas grill. Keep this outdoor cooking appliance clear and free from combustible materials, gasoline and other flammable vapors and liquids.
- Remove grill covers and store at least 36 inches from the LP gas grill while in use. Grill covers are made of a flammable material. Allow the grill to completely cool before putting the cover back on the grill.
- Keep any electrical supply cord and regulator hose away from any heated surfaces.
- Do not operate a gas grill if you are aware of or suspect a gas leak.
- Make sure there are no gas leaks or obstructions to the flow of combustion and ventilation air before each use.
- Keep the ventilation openings of the LP cylinder enclosure free and clear from debris.
- Always open the hood before lighting the LP gas grill to prevent an explosion from accumulation of gas.
- Do not use the grill without the Drip Cup in place. Empty excess grease to avoid a fire under the grill.
- If you notice grease or other hot material dripping from the grill onto the valve, hose, or regulator, turn off the gas supply immediately. After the grill has cooled, determine the cause and correct it. After cleaning the valve and hose and regulator assembly, perform a leak test before continuing use. ([See Performing a Leak Test.](#))

- Do not attempt to extinguish a grease fire with water or other liquids. Have an BC fire extinguisher accessible. Do not douse or spray the grill or cooking surfaces with water when hot. Burns from grease or the water splatters could occur.
- If your gas grill catches on fire:
 - If the fire is in the grill portion and you can safely reach the control knobs on the control panel, then turn them to the off position.
 - If the fire is in one of the hoses, and you can safely reach the LP cylinder valve, then shut the valve off.
 - If the fire involves the cylinder, leave it alone, evacuate the area and call the fire department.
 - If there is any type of fire that threatens either personal safety or endangers property, call the fire department.
- Do not wear loose clothing (example: hanging shirt tails, clothing with frills, etc.) around a gas grill while in use or hot.
- Do not lean your body over the gas grill when lighting it or while it is in use or hot.
- Do not touch hot surfaces. Use heat resistant gloves, long-handled tongs, or cooking mitts at all times since the grill will become very hot. Open the hood carefully when cooking to avoid burns from the hot air and steam trapped inside.
- Do not allow children to operate or play near a gas grill. Keep animals and bystanders out of the grill area. Do not leave grill unattended.
- Do not move an LP gas grill when in use or hot.
- When grill is not in use, turn off all grill control knobs, LP cylinder valve and disconnect the LP cylinder.

END OF COOKING SESSION

WARNING

To reduce the risk of serious bodily injury, fire or death:

- Allow grill and grease in the Drip Cup to completely cool before emptying, handling parts, cleaning, moving or storage.
 - Empty the Drip Cup after each cooking session so excessive grease does not accumulate.
 - Never light the LP gas grill without the Drip Cup in place.
- 1) After each cooking session, close the hood and turn the grill burners to the "High" position and burn for five minutes. This procedure will burn off cooking residue, thus making cleaning easier. (Side Burner not affected)
 - 2) When you have finished using your grill, turn the grill Control Knobs clockwise to the "Off" position.
 - 2) Turn off the gas at the LP cylinder valve by turning the handle clockwise until it stops.
 - 3) Wait until the grill is cool before closing the hood, cleaning or putting on the cover.
 - 4) Regularly clean your LP gas grill between uses and after extended storage periods. To maintain the condition and extend the life of your grill, we strongly recommend that the unit be covered when stored outside for any length of time, especially during the winter months.

CARE AND MAINTENANCE

⚠ CAUTION

To reduce the risk of a cut injury:

- Be careful or wear protective gloves when cleaning grill parts that have sharp edges.

CLEANING THE GRILL

- 1) Remove Drip Cup, Cooking Grid, and Flame Diffuser.
- 2) **Drip Cup**-Wash the Drip Cup with soap and water.
- 3) **Grill Body and Cart**-Do not mistake the accumulation of grease and smoke residue for peeling or flaking paint. Remove excess grease and/or fat with a soft plastic or wooden scraper. Do not use steel wool or other abrasive cleaners that can scratch painted or porcelain coated surfaces. It is not necessary to remove all the grease from the body. Wipe it down with paper towels or soft damp cloth.
- 4) **Warming Rack**-Clean if necessary with soap and water.
- 5) **Cooking Grid/Flame Diffuser.** Clean the residue off with hot soap and water, or baking soda. For stubborn stains, use a non-abrasive scouring powder. Do not use steel wool or other abrasive cleaners that can scratch the porcelain coated surfaces. This can cause foods to stick on the Cooking Grids.
- 6) **All other Cleaning**-For further cleaning, use hot soapy water and a cloth, or nylon-bristled brush only. Do not immerse the gas controls or manifold in water. (Avoid getting water in the Burner Holes.)
- 7) **Burner**-Burning off the residue after cooking will keep the burner clean with normal usage, provided the Burner is operating correctly. Clean the the Burner annually, or whenever heavy build-up is found, to ensure that there are no signs of blockage (debris, insects) in either the burner portholes, the primary air inlet, or the neck of the burner. **(See Burner Cleaning instructions.)**
- 8) After cleaning, replace all the cleaned parts. Re-tighten Burner and Heat Shield screws.

⚠ WARNING

To reduce the risk of a fire beneath the grill:

- Inspect and clean burner/venturi tubes for insects and insect nests.
- Be sure burners are re-installed properly before using grill.
- Inspect burners periodically, if large cracks or holes are found, replace the Burner.

⚠ CAUTION

SPIDER ALERT!

Should you notice that your burner(s) are getting hard to light or the flame is not as hot as it once was, Refer to the “**How to Clean your Burners**” Section to remove any possible obstructions.

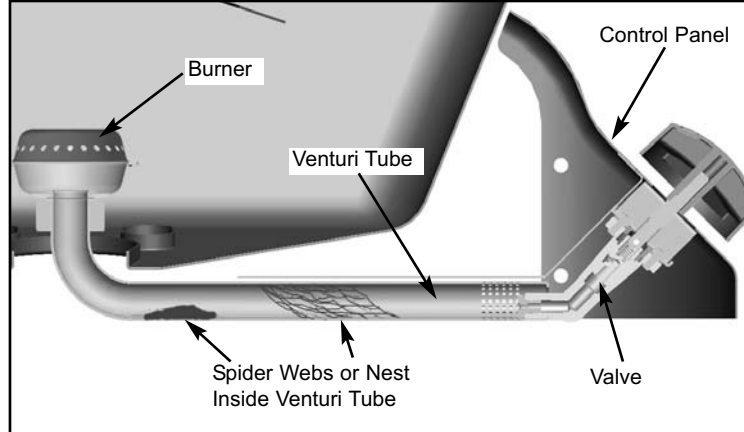

Spiders or small insects can build nests, webs and lay eggs in the grill's venturi tubes obstructing the flow of gas to the burner. The backed-up gas can ignite behind the control panel causing damage to the grill and even injury to the operator. This is known as a “flashback”.

In order to prevent flashbacks, the burner(s) should be removed from the grill and cleaned periodically, especially if the grill has been stored for an extended period of time.

How to Clean the Burner:

- 1) Make sure the LP cylinder grill control knobs are turned OFF and the grill is completely cooled.
- 2) Carefully remove Drip Cup, Cooking Grid and Flame Diffuser.
- 3) Remove the Heat Shield under the bottom of grill Bowl by removing the screw (**FIG. 15A**) then the two bolts and wingnuts securing the Heat Shield to the Left Sidebrace. (**FIG. 15B**) Just let the Heat shield hang on the Drip Cup holder.
- 4) Remove the two Burner screws from the bottom of grill Bowl. (**FIG. 15C**) Lift Burner out from the top of the grill.

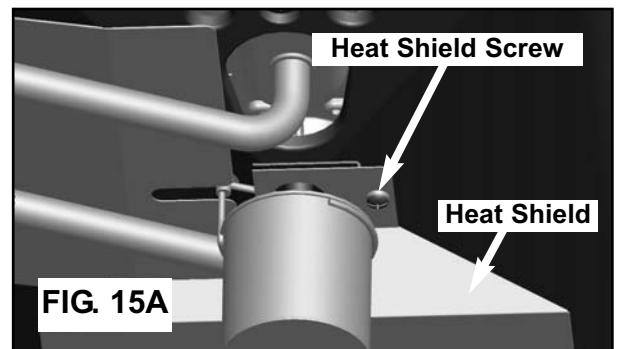

- 5) Use a pipe cleaner to clear insect nests from the inlet hole of main burner (**FIG. 15D**). Open up the main burner holes with a small nail or wire. Normal wear and corrosion may enlarge some holes, however, if large cracks or holes are found, replace the Burner. Use a brass wire brush to remove food particles and corrosion from the burner surface. (Note: It is normal for surface rust to be present on the burners.) It can be wire brushed and coated with cooking oil periodically. Verify that there are no insects or insect nests blocking the inlet hole. Before next step you may wish to clean the rest of the Grill Bowl inside. (**See Grill Body and Cart Cleaning.**)
- 6) If grill is to be stored, coat Burner lightly with cooking oil and wrap in a protective cover to keep insects out.
- 7) After cleaning, re-install the Burner. Be sure that it is positioned correctly. The valve nozzles should fit inside the venturi ends of the burner. (**See FIG. 15C**)
- 8) Re-attach Heat Shield to bottom of Bowl and Side Crossbrace.
- 9) Check burner operation after re-assembly.
- 10) Replace Grease Cup, Flame Diffuser and Cooking Grid.

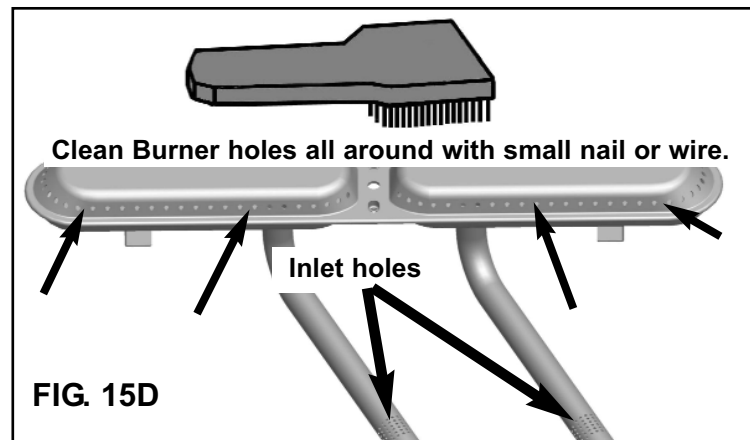
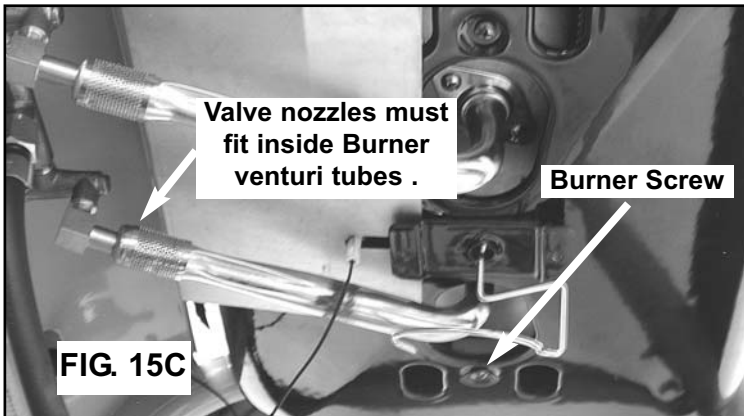
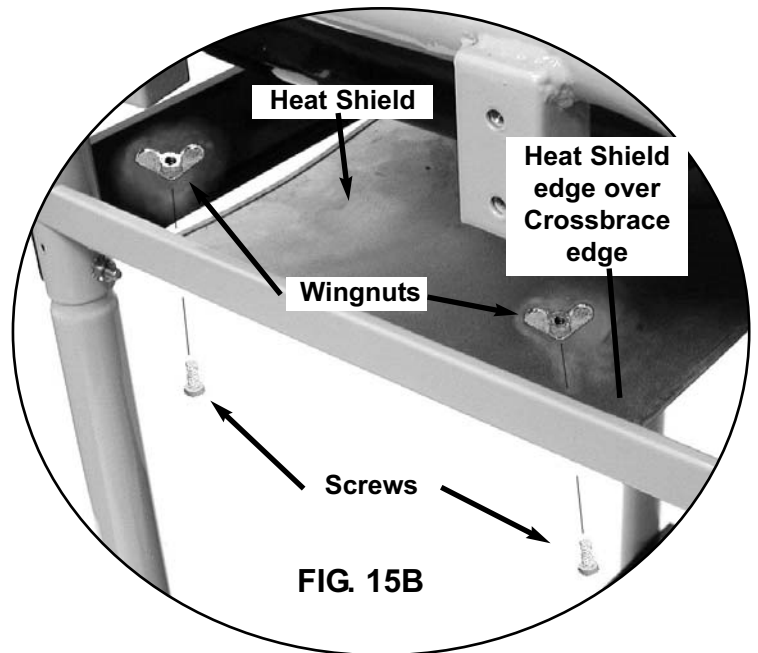

STORAGE

⚠ WARNING

To reduce the risk of serious bodily injury or death:

- Store your LP gas grill in a cool dry place. Do not store an LP gas cylinder in a space greater than 125 degrees Fahrenheit. Do not store an LP gas cylinder in a building ,garage or any enclosed area.
- Do not store an LP gas cylinder indoors (empty or filled). Disconnect the LP gas cylinder from the gas grill and store it outdoors out of the reach of children. The gas grill may then be stored indoors.
- To avoid an explosion, do not leave an LP gas cylinder inside a vehicle that can become overheated by the sun.
- Even though your LP gas cylinder may appear to be empty, gas may still be present and the cylinder should be transported and stored accordingly.
- Do not store a spare LP gas cylinder under or near the LP gas grill.
- Always turn off the gas cylinder at the LP cylinder valve when the gas grill is not in use.

- 1) Disconnect LP gas cylinder from grill and store outside, in a dry, well-ventilated area, away from any sources of heat or ignition. Re-cap LP cylinder valve with the Safety Cap.
- 2) Remove Burner and wrap with aluminum foil to prevent insects from entering the burner holes. Store wrapped Burner on top of cooking grid.
- 3) You may wrap the Cooking Grid and Flame Diffuser in aluminum foil and place inside the Hood or store inside your dwelling.
- 4) Place a grill cover over the grill and store the gas grill outdoors if possible. It may be stored indoors only if the LP cylinder is disconnected from the gas grill.
- 5) Before next use, remove aluminum foil and reinstall Burner, Flame Diffuser, and Cooking Grid.
- 6) Before using the grill after periods of storage or non-use (i.e. over winter), check your LP gas grill for gas leaks, deterioration, proper assembly, and burner obstructions.
- 7) Periodically check and tighten all nuts, bolts, and screws.

Gas Leaks and Fire Emergencies

<u>Problem</u>	<u>Possible Cause</u>	<u>Solution</u>
Gas leaking from cracked/cut/burned hose.	Damaged hose.	Turn off gas at the LP cylinder. Replace valve/hose/regulator before continuing use.
Gas leaking from LP cylinder	Mechanical failure due to rust or mishandling.	Replace LP Cylinder
Gas leaking from LP cylinder valve	Failure of valve from mishandling or mechanical malfunction.	Turn off LP cylinder valve. Return cylinder to gas supplier.
Gas leaking between LP cylinder and regulator connection.	Improper installation, connection not tight, failure of rubber seal.	Turn off LP Cylinder valve. Remove regulator from cylinder and visually inspect rubber seal for damage. See “Leak Test” and “Connecting Regulator to LP Cylinder” sections.
Fire coming through control panel	Fire in or around venturi tube section of the burner.	Turn off control knobs and LP cylinder valve. Once fire is out and grill has cooled off. Remove burner(s) and inspect for blockage from spider webs/nests or rust. See “How to clean your burners.” section.
Grease fire or excessive flames above cooking surface.	Too much grease build-up in burner section.	Turn off control knobs and LP cylinder valve. Once fire is out and grill has cooled off. Clean residual food particles and excess grease from inside firebox area, grease cup and other surfaces.
Flashback.... (fire in or around venturi tubes.	Too much grease build-up in burner section.	Turn control knobs to “OFF”. Clean burner and venturi tubes. “See “How To Clean Burners” Section.

Troubleshooting

<u>Problem</u>	<u>Possible Cause</u>	<u>Solution</u>
Burners will not light using the ignitor	Burners not assembled correctly	See re-assembly after cleaning in Care and Maintenance .
	Not pausing long enough before clicking the Ignitor	When lighting the Burner, push-in and turn control panel knob counter-clockwise to the high position. Pause 4 seconds, then Push in Ignitor button several times so that it clicks each time.
	No spark, electrode cracked, broken or loose.	<ol style="list-style-type: none"> 1-Make sure all the wires are connected and to the right terminals. 2-If Electronic, check the battery. Make sure it is pushed in the holder. 3-Gas collector tab is bent (making too large or small of a gap between electrode and tab). By hand, bend gas collector tab back within a maximum of 3/16” gap to electrode. (Page 16) 4-Tighten Electrode mounting screws. 5-Replace damaged electrodes.
	LP- gas cylinder is empty	Take LP gas cylinder to licensed LP gas supplier to be refilled.
	Regulator Coupling nut is not fully connected to LP cylinder	Tighten coupling nut by hand about one-half to three quarters additional turn. Do not use tools.

TROUBLESHOOTING (Cont'd)

<u>Problem</u>	<u>Possible Cause</u>	<u>Solution</u>
Burners will not light using the ignitor	LP-Excess flow valve tripped in regulator. Vapor lock in connections. Obstructions in burners Wet Electrodes and burners Wire loose or disconnected Wire shorting (sparking between ignitor and electrode)	Turn control knobs to “off” position and turn LP gas cylinder handle clockwise until it stops. Wait five minutes. Relight LP gas grill. If flame continues to be low, turn off gas at cylinder and grill. Disconnect the regulator from the LP gas cylinder. Reconnect the regulator to the LP gas cylinder. Perform a leak test. Relight grill. This will reset the excess flow valve. Clean the burners. (See How to Clean the burners in Care and Maintenance .) Dry electrode with clean cloth. Air dry or use blow dryer. Reconnect the wire. Replace ignitor wire/electrode assembly (Call the Customer Service Department).
Burners will not light using a match	Burners not assembled correctly LP-gas cylinder is empty LP-Excess flow valve tripped in regulator Regulator Coupling nut is not fully connected to LP cylinder Obstructions in burners	See re-assembly after cleaning in Care and Maintenance . Take LP gas cylinder to licensed LP gas supplier to be refilled Turn control knobs to “off” position and turn LP gas cylinder handle clockwise until it stops. Wait five minutes. Relight LP gas grill. If flame continues to be low, turn off gas at cylinder and grill. Disconnect the regulator from the LP gas cylinder. Reconnect the regulator to the LP gas cylinder. Perform a leak test. Relight grill. This will reset the excess flow valve. Tighten coupling nut by hand about one-half to three quarters turn. Do not use tools. See How to Clean the Burners in Care and Maintenance .
Low flame or low heat	LP-Gas in LP cylinder is low OR Natural Gas supply pressure is low Excess flow valve tripped in regulator	Check LP gas cylinder. Refill if necessary. Turn control knobs to “off” position and turn LP gas cylinder handle clockwise until it stops. Wait five minutes. Relight LP gas grill. If flame continues to be low, turn off gas at cylinder and grill. Disconnect the regulator from the LP gas cylinder. Reconnect the regulator to the LP gas cylinder. Perform a leak test. Relight grill. This will reset the excess flow valve.
Flames blow out	High or gusting winds Gas in LP cylinder is low Excess flow valve tripped	Turn front of grill away from wind or increase flame height. Check LP gas cylinder. Refill if necessary. See “Low flame” problem above.
Flare up	Grease build up Excessive fat in meat	Clean grill. Trim fat from meat before grilling.
Persistent grease fire	Grease trapped around burner system	Turn control knobs “off” and turn handle of LP cylinder clockwise until it stops. Open hood carefully and let fire burn out. After the grill cools, remove and clean all parts.
Unable to fill LP tank	Some dealers have older fill nozzles with worn threads.	The worn nozzles don’t have enough “bite” to engage the valve. Try another licensed LP dealer.

TROUBLESHOOTING (Cont'd)

Humming or whistling from the regulator

Outside temperature, humidity, barometric pressure, and the gas level within the tank may cause the rubber diaphragm inside the regulator to vibrate, making a humming or whistling sound.

Although this sound may be alarming, this is NOT dangerous as long as it is not accompanied by the smell of gas. Simply adjust the burner settings and usually the sound will subside. If the humming sound persists, a change in atmospheric conditions will eventually stop the vibration. Should you smell gas, do not use the grill and call Customer Service at 1-800-251-7558

If your problem is not resolved from the information provided above, please call Customer Service at 1-800-251-7558.

IMPORTANT NOTICE

This Gas Grill must be used with a LP Gas Cylinder equipped with an OPD (Overfill Prevention Device).

This is a secondary device to prevent the overfill of your LP Gas cylinder. The proper methods for the filling of your LP Gas cylinder are by weight or volume, as described in NFPA 58. Please make sure your filling station fills your LP Gas cylinder by weight or volume. Ask your filling station to read purging and filling instructions on the LP cylinder before attempting to fill.

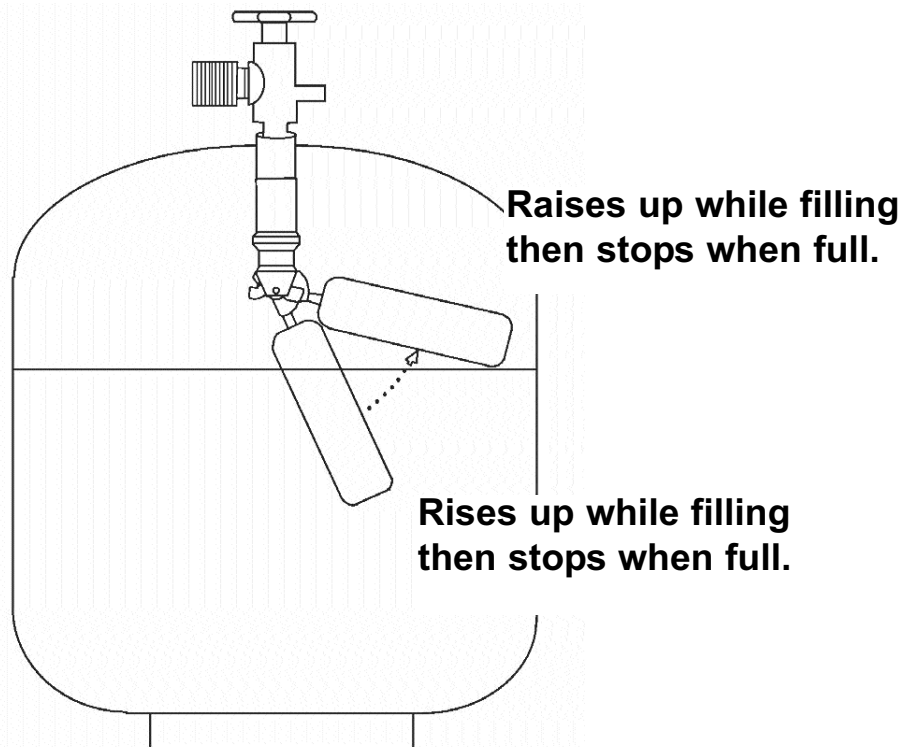

⚠️ WARNING

Do not exchange the LP Gas cylinder unless the exchange LP cylinder is equipped with an OPD. Otherwise you will lose the OPD (Overfill Prevention Device) feature. If there is not an LP cylinder available for exchange equipped with an OPD, we recommend that you have your cylinder filled at an authorized LP gas dealer by a qualified attendant.

MECO CORPORATION
LIMITED WARRANTY

This product is warranted to the original consumer purchaser against defects in material and workmanship under normal outdoor household use and correct assembly (if assembled by the consumer-purchaser). Burner and Cooking Grid are warranted for a period of one (1) year from the date of purchase. All other parts are warranted for a period of one (1) year from the date of purchase.

Meco Corporation requires proof of purchase and we suggest you keep your receipt. Damages caused by commercial or institutional use, accidental or intentional damage, repairs made or attempted by unauthorized persons, or misuse are not covered by this warranty. If defective, the part or product will be repaired or replaced at the option of Meco Corporation without charge.

This warranty does not include the cost of any inconvenience or property damage due to failure of the product and does not cover damage due to misuse, abuse, accident, damage arising out of transportation of the product, damage incurred through commercial use, or failure to perform normal and routine maintenance. LIABILITY FOR CONSEQUENTIAL PROPERTY OR COMMERCIAL DAMAGES ARE EXPRESSLY EXCLUDED BY THIS WARRANTY. ANY APPLICABLE IMPLIED WARRANTIES OF MERCHANTABILITY AND FITNESS ARE LIMITED IN DURATION TO THE PERIOD COVERAGE OF THIS EXPRESS WRITTEN LIMITED WARRANTY. Some states do not allow limitation on how long an implied warranty lasts, so this limitation may not apply to you.

Deterioration or damage due to severe weather conditions such as hail, hurricanes, earthquakes or tornados, discoloration due to exposure to chemicals either directly or in the atmosphere, is not covered by this limited warranty.

No returns will be accepted without prior authorization from Meco Corporation. Authorization for return may be obtained by calling 1-800-251-7558. Handling and transportation costs for returning the product are not covered by this warranty and will be paid for by the purchaser. Please send your correspondence to:

MECO CORPORATION
Attn: Customer Service
1500 Industrial Road
Greeneville, TN 37745

For reference and correspondence,
record your Serial number here.
(See nameplate on side of grill.)

Serial No. _____
Please use this number in registering
your warranty and any correspondence
with Meco Corporation.

Aussie®