

## Tabletop Gas Grill

**WARNING**

Improper installation, adjustment, alteration, service or maintenance can cause injury or property damage. Read the installation, operation and maintenance instructions thoroughly before installing or servicing this equipment. Failure to follow these instructions could result in fire or explosion which could cause property damage, personal injury or death.

**PROP 65 WARNING**

Chemicals known to the state of California to cause cancer, birth defects, or other reproductive harm are created by the combustion of propane.

**DANGER!**

DO NOT use gas grill for indoor cooking or heating. TOXIC fumes can accumulate and cause asphyxiation. NOT to be used in or on boats or recreational vehicles.

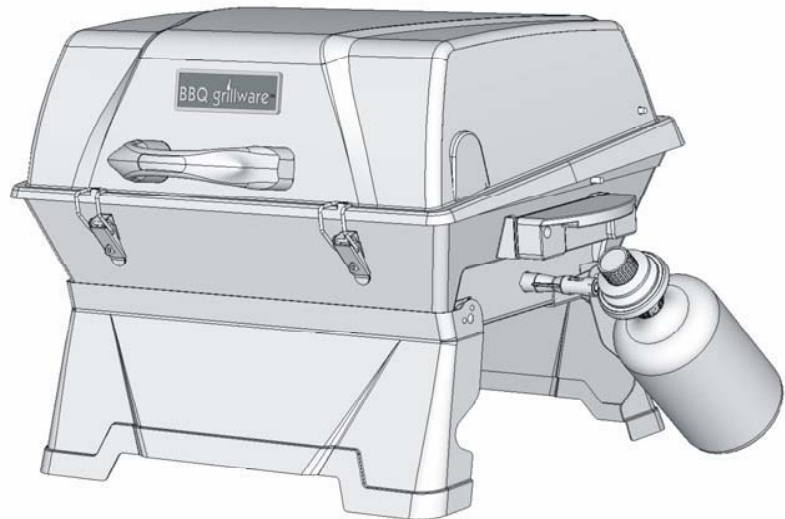

**WARNING**  
FOR YOUR SAFETY :

For Outdoor Use Only  
(outside any enclosure)

SAVE THESE INSTRUCTIONS FOR FUTURE REFERENCE. IF YOU ARE ASSEMBLING THIS UNIT FOR SOMEONE ELSE, GIVE THIS MANUAL TO HIM OR HER TO SAVE FOR FUTURE REFERENCE.  
FOR CUSTOMER SERVICE, CALL 1-877-885-8227,  
6 A.M. – 5 P.M. PST, MONDAY-FRIDAY.



# Table of Contents

For Your Safety.....	2
Illustrated Parts List .....	3
Assembly Instructions.....	5
Operating Your Grill	Connecting Gas Cylinder.....11
	Check for Leaks.....12
	Lighting Your Grill.....12
	Cleaning and Care.....13
Award- Winning Barbecue Recipes.....	14
Gas Grill Troubleshooting.....	15
Warranty.....	16
Manufacturer Information.....	16

## Dear Valued Customer,

Congratulations on your new barbecue grill! You’ve made the right choice. In this manual, you will find assembly instructions, suggestions for grilling and helpful hints, as well as guidelines for the safe operation, proper care and use of your grill. Our expert staff strives to provide you with an easy to assemble product. Should you have any questions, problems or missing parts with this product, please call our customer service department at 1-877-885-8227, 6:00AM to 5:00PM (PST). Monday through Friday.

**NOTE:** The use and installation of this product must conform to local codes. In absence of local codes, use the National Fuel and Gas Code, ANSI Z223.1/ NFPA 54, Storage and Handling of Liquefied Petroleum Gases, ANSI / NFPA 58

**IMPORTANT NOTICE: READ ALL INSTRUCTIONS PRIOR TO ASSEMBLY AND USE!**

**WARNING**  
**FOR YOUR SAFETY**

***If you smell gas:***

- 1. Shut off gas to the appliance.**
- 2. Extinguish any open flame.**
- 3. Open Lid.**
- 4. If odor continues, immediately call your gas supplier or fire department.**

**WARNING**  
**FOR YOUR SAFETY**

- 1. DO NOT store or use gasoline or other flammable vapors and liquids within 25 feet (8m) of this or any other appliance.**
- 2. An LP Cylinder not connected for use shall NOT be stored within 10 feet (3m) of this or any other appliance.**

**Safety First!**

**Read and understand all warnings and precautions prior to operating your grill.**

**DANGER**

**To prevent fire or explosion hazard when testing for a leak:**

1. Always perform the "leak test" on page 12 before lighting the grill and each time the cylinder is connected for use.
2. Do not smoke or allow other sources of ignition in the area while conducting a leak test.
3. Conduct the leak test outdoors in a well-ventilated area.
4. Do not use matches, lighters or a flame to check for leaks.
5. Do not use grill until any and all leaks are corrected. If you are unable to stop a leak, disconnect the propane supply. Call a gas appliance serviceman or your local propane gas supplier.

**WARNING**

1. This grill is for outside use only, and shall not be used in a building, garage, or any other enclosed area.
2. This grill is for use with propane gas only (propane gas cylinder not included).
3. Never attempt to attach this grill to the self-contained propane system of a camper trailer, motor home, or house.
4. Never use charcoal or lighter fluid.
5. The use of alcohol, or prescription or non-prescription drugs may impair the consumer's ability to properly assemble or safely operate the appliance.
6. Do not use gasoline, kerosene, or alcohol for lighting! The propane supply cylinder must be constructed and marked in accordance with the specifications for propane cylinders of the U.S. Department of Transportation (DOT) CFR 49. This grill is not intended to be installed in or on recreation vehicles and/ or boats.
7. Always open grill lid carefully and slowly as heat and steam trapped within grill can severely burn you.
8. Always place your grill on a hard, level surface far away from combustibles. An asphalt or blacktop surface may not be acceptable for this purpose.
9. Do not attempt to move the grill while it is lit
10. Do not leave a lit grill unattended, *especially* keep children and pets away from grill at all times.
11. Do not use grill in high winds.
12. Do not use the grill unless it is *COMPLETELY* assembled and all parts are securely fastened and tightened.
13. Keep all combustible items and surfaces at least 12 inches (30 cm) away from the grill at all times. **DO NOT** use this gas grill or any gas product under any overhead or near any unprotected combustible constructions.

**CAUTION**

1. Do not touch metal parts of grill until it has completely cooled (about 45 minutes) to avoid burns, unless you are wearing protective gear (pot holders, gloves, BBQ mittens, etc.).
2. Do not use in an explosive atmosphere. Keep grill area clear and free from combustible materials, gasoline and other flammable vapors and liquids.
3. Do not alter grill in any manner.
4. Do not repair or replace any part of the grill unless specifically recommended in this manual. All other service should be referred to a qualified technician
5. Never keep a filled container in a hot car or car trunk. Heat will cause the gas pressure to increase, which may open the relief valve and allow gas to escape.

**CAUTION**

- Liquid propane (LP) gas is flammable and hazardous if handled improperly. Become aware of the characteristics before using any propane product.
- Propane Characteristics: Flammable, explosive under pressure, heavier than air, and settles and pools in low areas.
- In its natural state propane has no odor. For your safety, an odorant has been added.
- Contact with propane can cause freeze burns to skin.
- This grill is shipped from the factory for propane gas use only.
- Never use propane cylinder with a damaged body, valve, collar or footing.
- Dented or rusted propane cylinders may be hazardous and should be checked by your propane gas supplier.
- It may be hazardous to attempt to fit other types of gas cylinder.









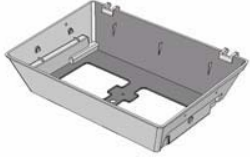
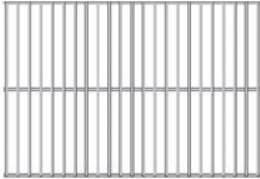
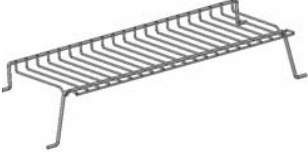
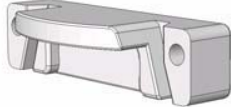
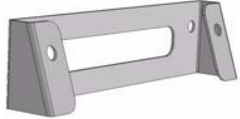
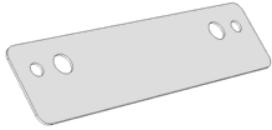

**CAUTION**

**It is essential to keep the grill's burner and circulating air passages clean. Inspect grill before each use.**

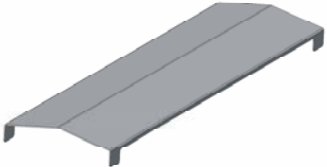

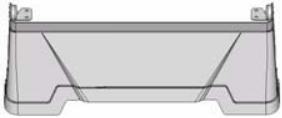





**GENERAL INFORMATION**

1. Propane gas cylinder required for operation.
2. This gas grill is NOT for commercial use!

### Illustrated parts list

<p>1.Lid.....1pc</p> 	<p>2. Handle.....1pc</p> 	<p>3. Body.....1pc</p> 
<p>4.Cooking grid.....1pc</p> 	<p>5.Warming grid.....1pc</p> 	<p>6.Side handle.....2pcs</p> 
<p>7.Body handle support...2pcs</p> 	<p>8.Heat insulation board...2pcs</p> 	<p>9.Burner.....1pc</p> 
<p>10.Heating plate.....1 pc</p> 	<p>11.Baffle board.....1pc</p> 	<p>12. Front support.....1pc</p> 
<p>13. Back support.....1pc</p> 	<p>14.Regulator valve.....1pc</p> 	<p>15. Fastener.....2pcs</p> 

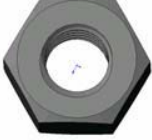
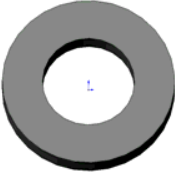
**A screwdriver is also included for your convenience.**

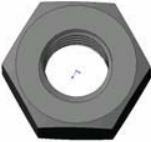
A	 <p>Bolt M5 x10MM</p>	8pcs	G	 <p>Clevis Pin Ø6.5 X 45MM</p>	2pcs
B	 <p>Bolt M6 x10MM</p>	1pc	H	 <p>Hair Pin Ø1.3MM</p>	2pcs
C	 <p>Bolt M5 x 45MM</p>	4pcs	I	 <p>Gasket</p>	2pcs
D	 <p>Lock Washer Ø6.0MM</p>	15pcs	J	 <p>Nut M5</p>	4pcs
E	 <p>Flat Washer Ø6MM</p>	11pcs	K	 <p>Screwdriver</p>	1pc
F	 <p>Nut M6</p>	2pcs			

## Assembly Instructions

### For Best Results

Remove all contents from packaging, and make sure all parts are present before attempting to assemble! Tighten all bolt connections by hand first, then when the grill is fully assembled, go back and tighten. It will take 15 to 20 minutes to assemble the grill. Wrench may be required for assembly (For M5 or M6 nut).

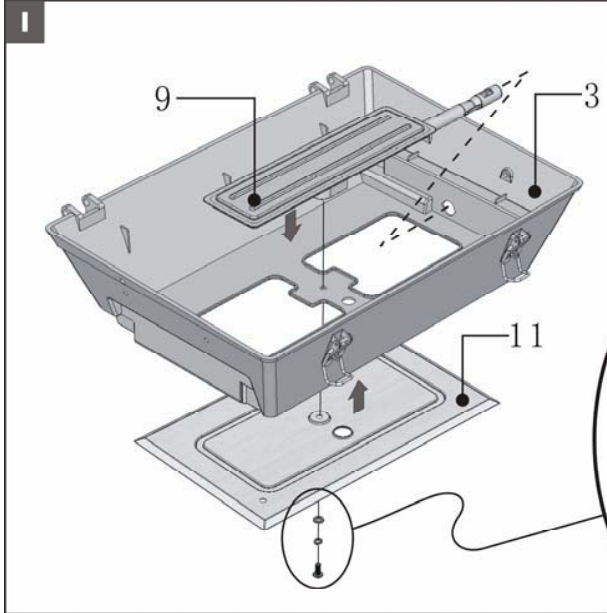

### Step 1

Install the burner body and baffle-board into the grill body as shown.

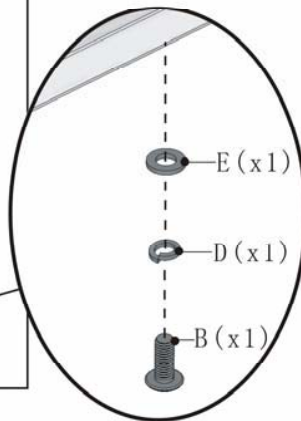

### Step 2

Fix the front support and back support onto the grill body as shown. Pull them outwards and make sure both supports/legs lock in place.

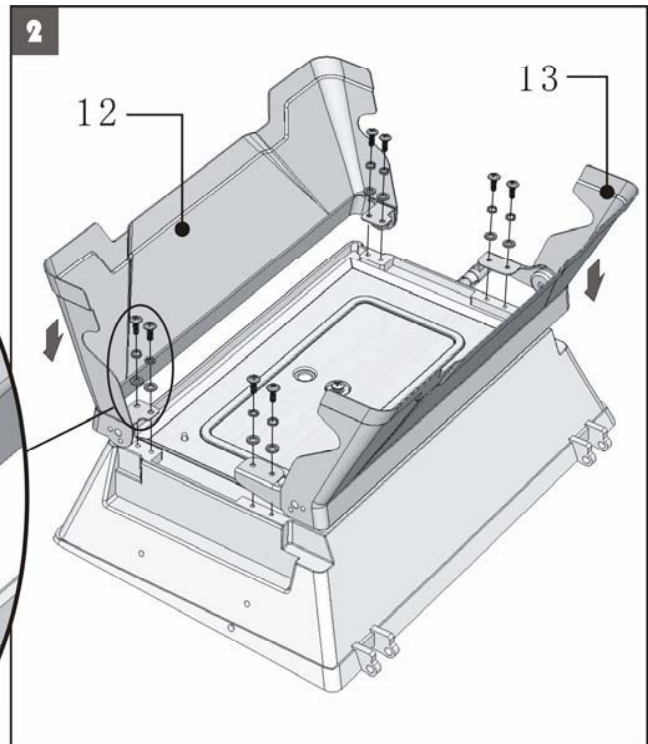
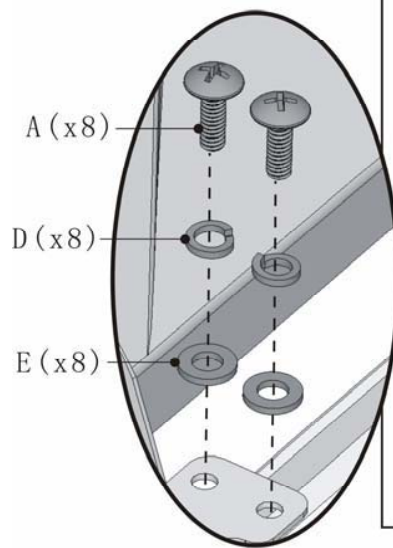

### Step 3

Fix side handles, heat insulation board, handle supports and fasteners to the grill body as shown.

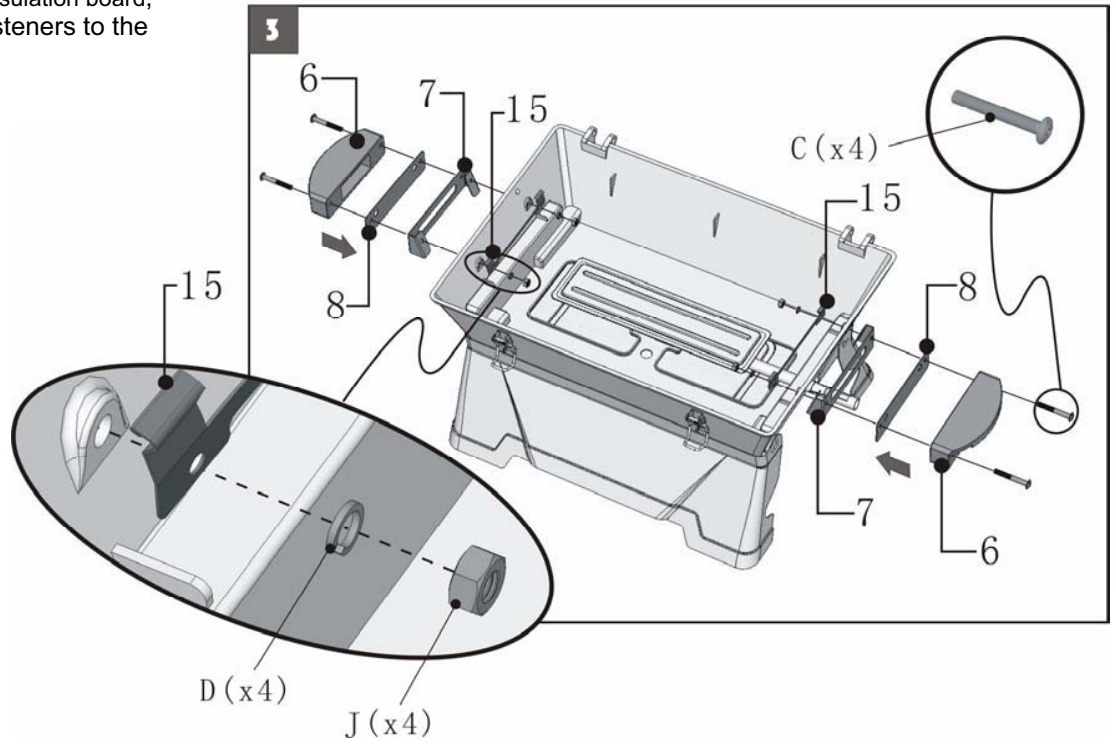

### Step 4

Install the lid handle on the lid as shown.

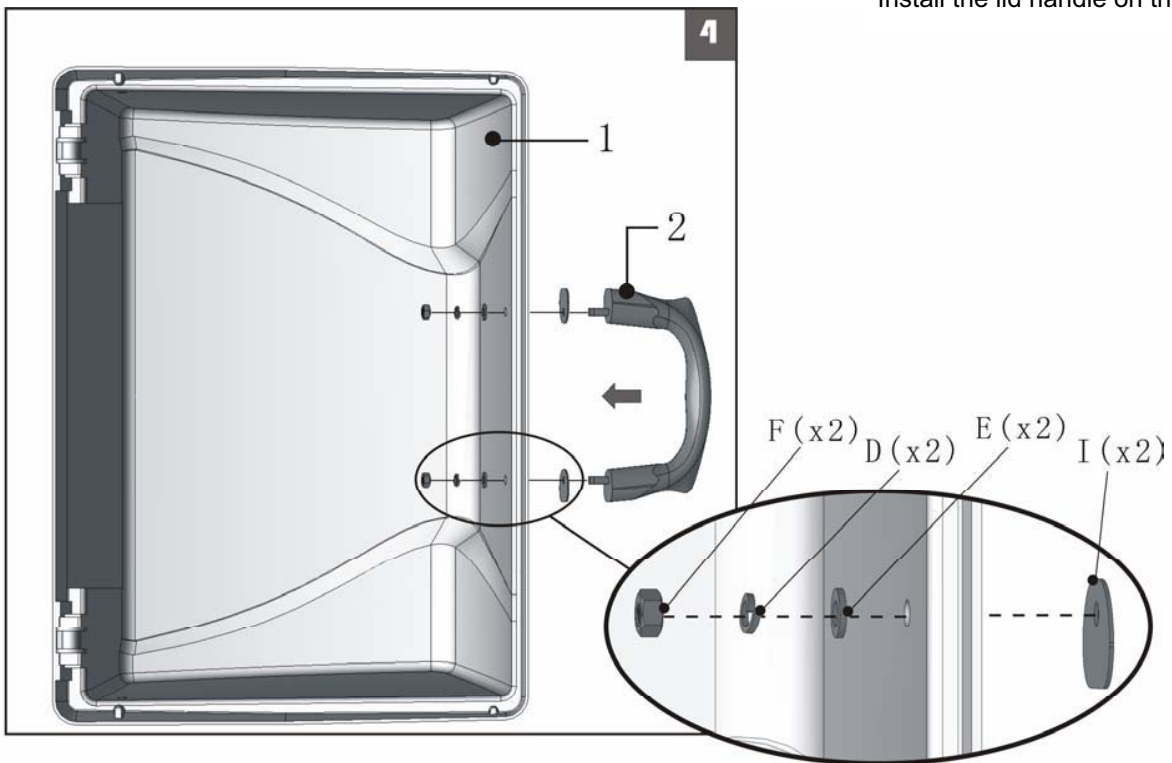



**Step 5**  
Install top lid set to the body as shown.

**Step 6**  
Connect the top lid and body with clevis pins.

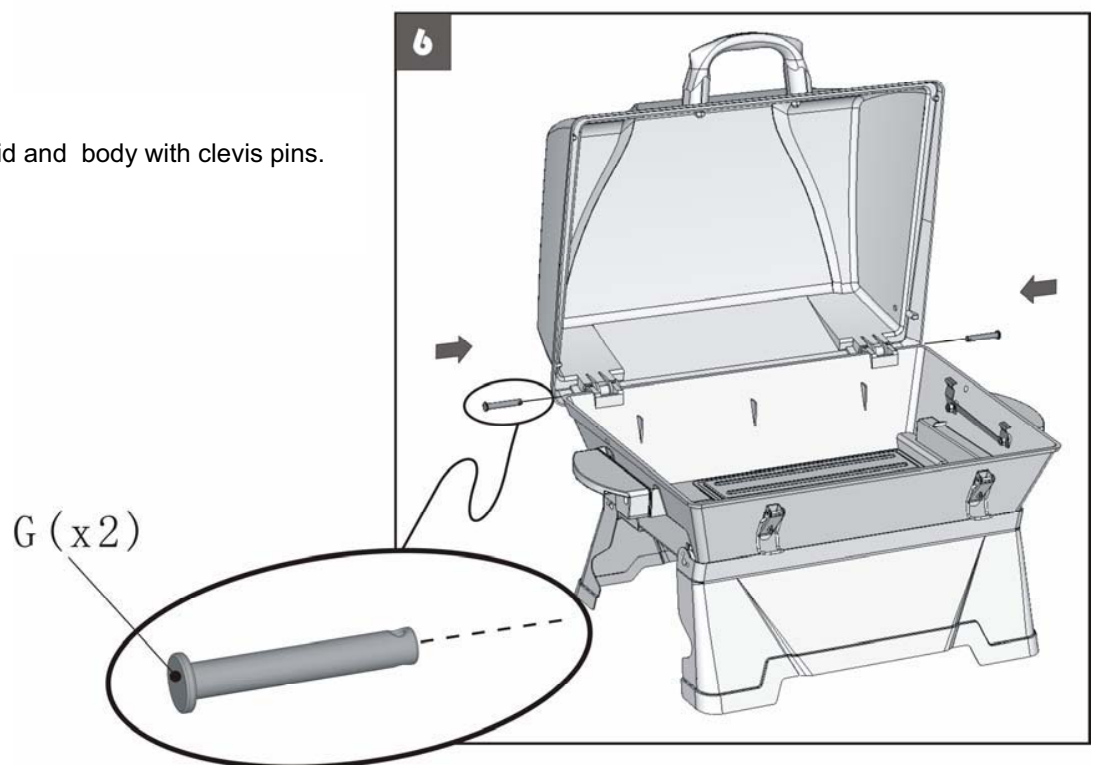

**Step 7**

Fasten the lid and body by inserting a hair pin through the hole in the end of each clevis pin.

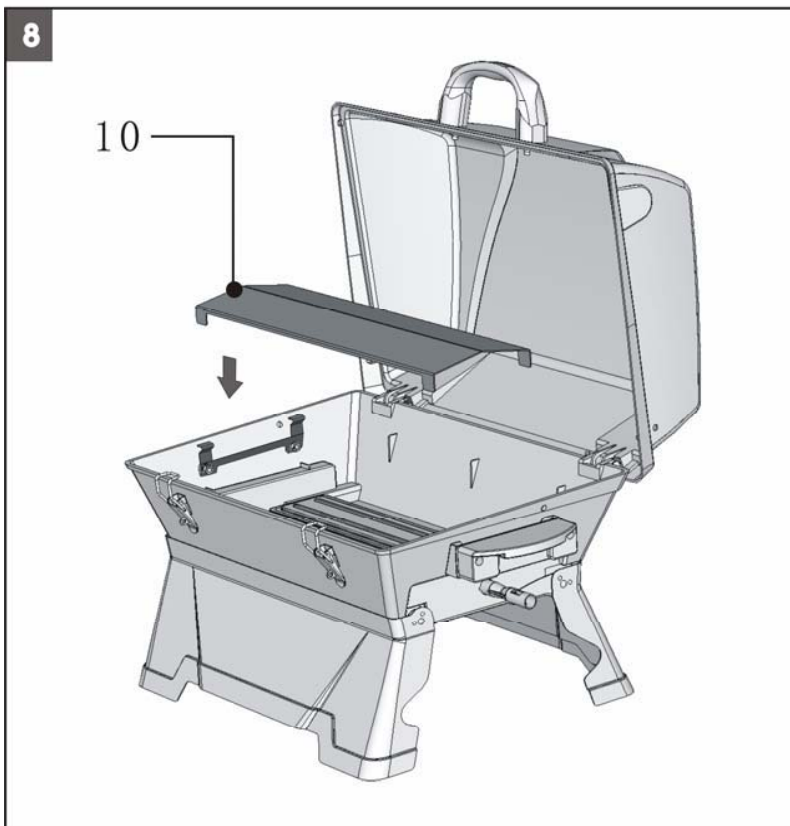
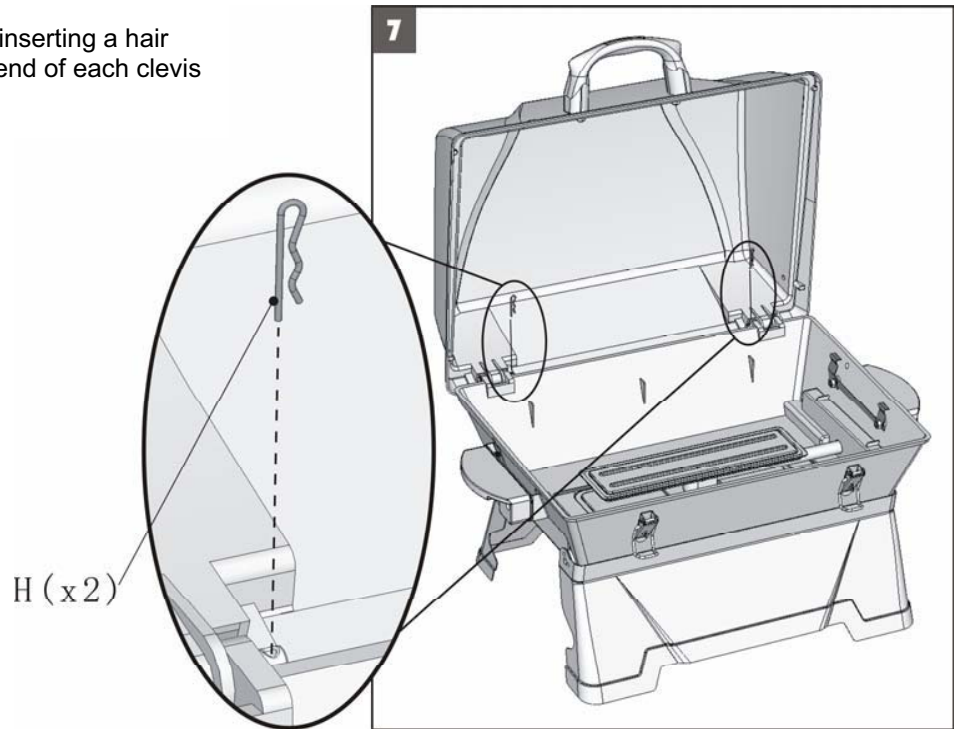

**Step 8**

Put the heating plate into the grill bottom upon the burner as shown.

9

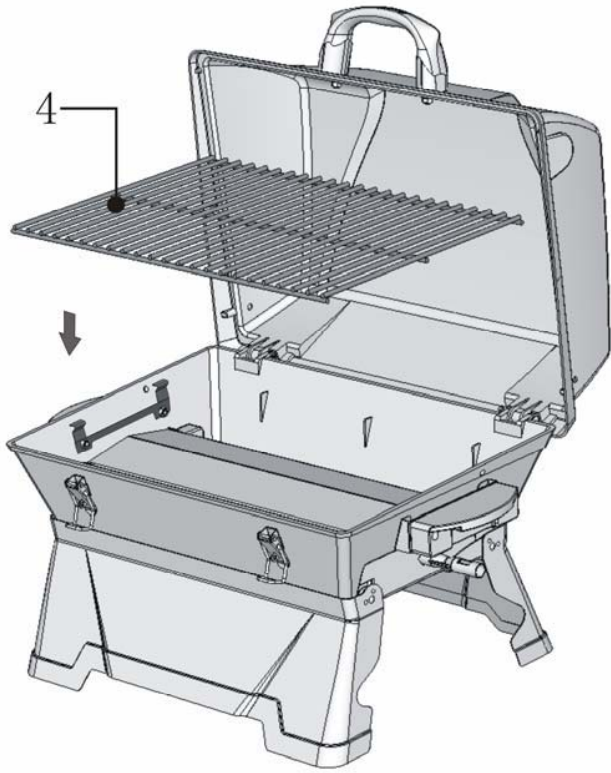

**Step 9**

Put the cooking grid onto the heating plate as shown.

**Step 10**

Install the warming grid between the lid and cooking grid as shown.

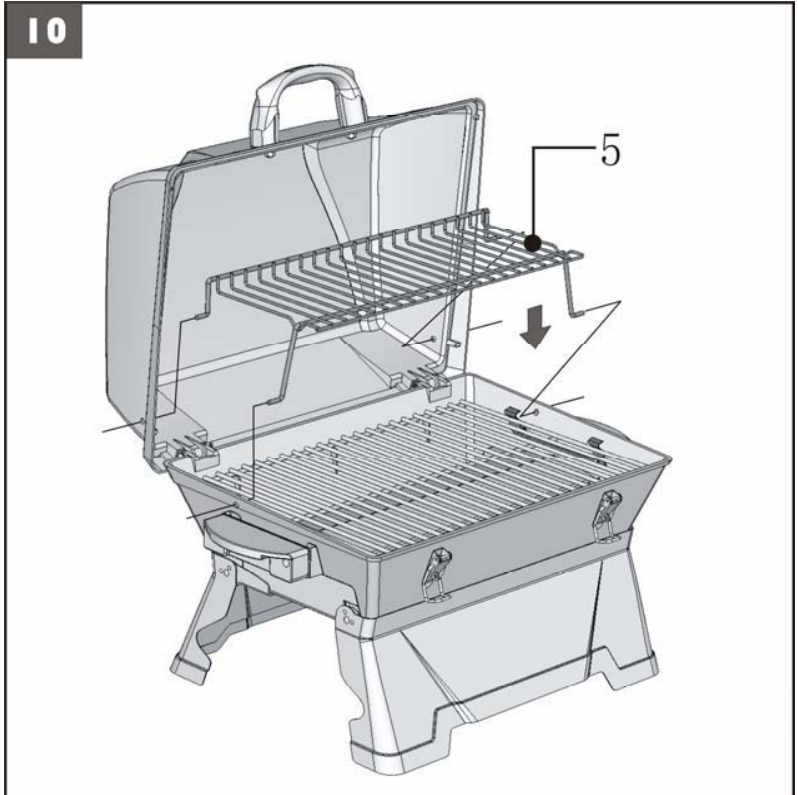

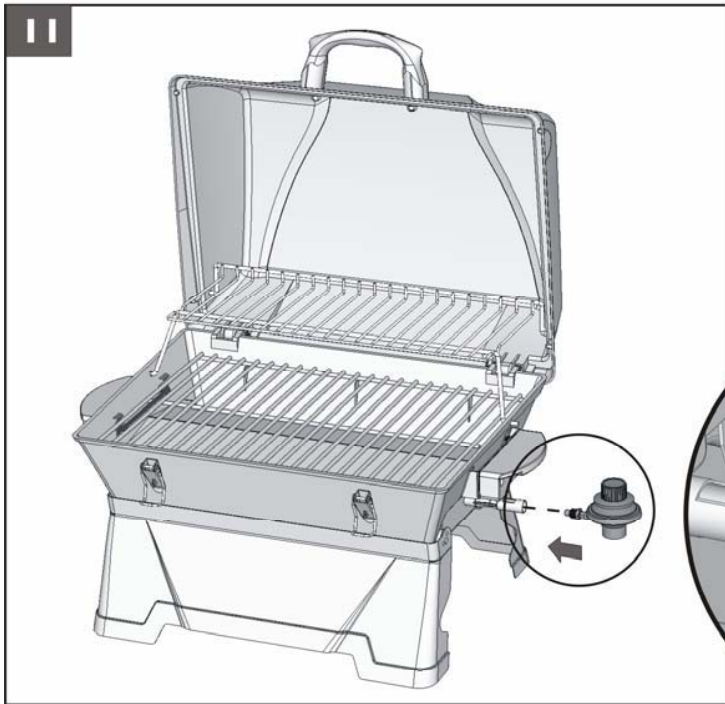

**Step 11**

Connect the regulator valve and the burner as shown.

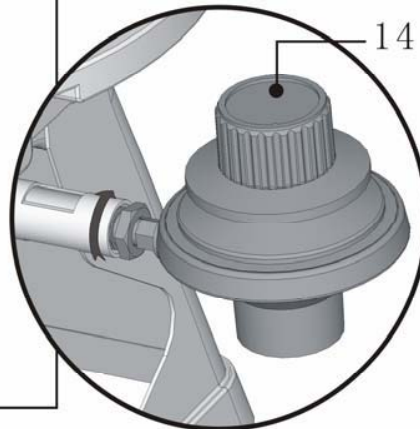

**Step 12**

- (1) Turn gas control dial to "OFF" position.
- (2) Connect propane cylinder to cylinder regulator inlet fitting by turning as shown
- (3) Tighten all bolts after completely assembling.

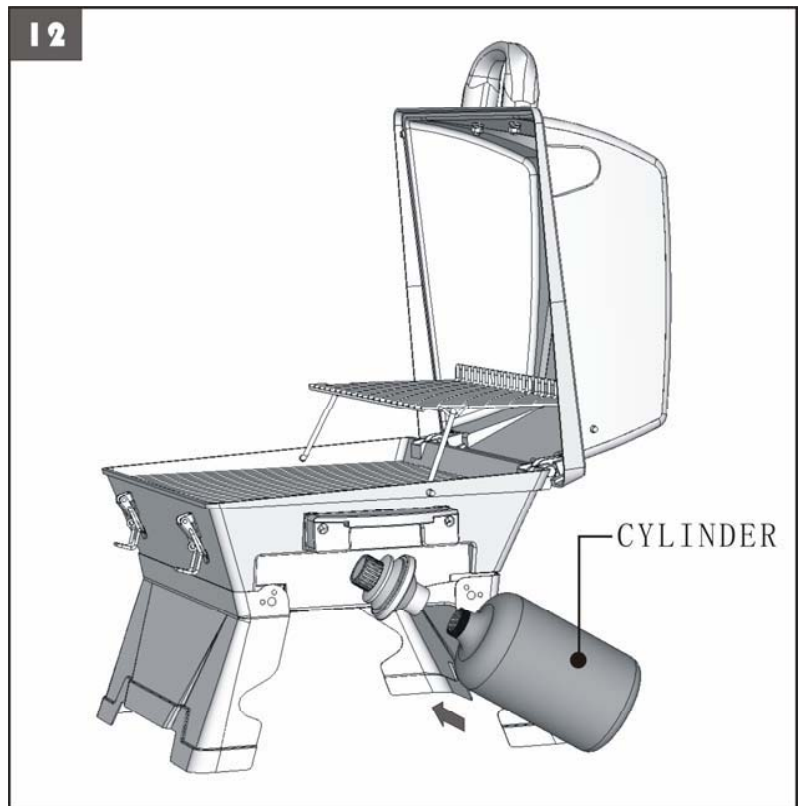

## Fully-Assembled

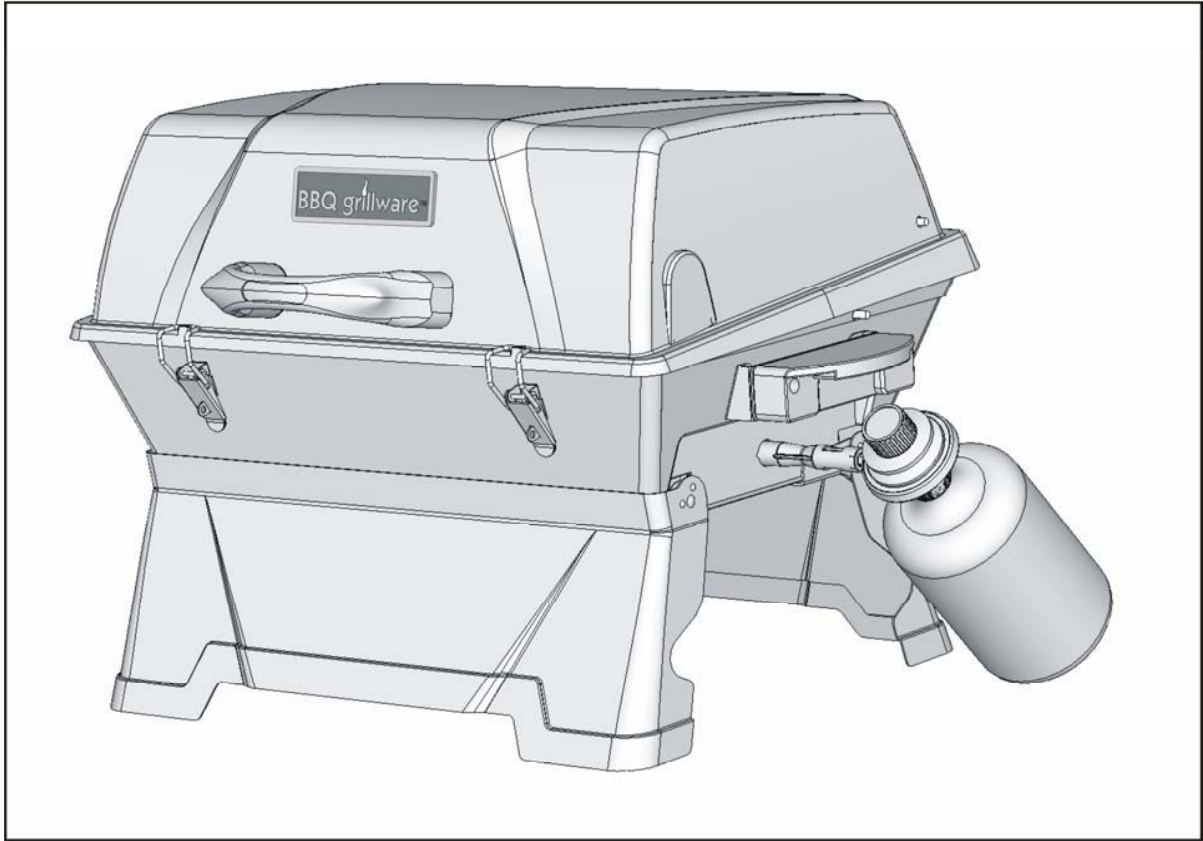

### OPERATING YOUR GRILL

**USE ONLY THE REGULATOR PROVIDED!**

**If a replacement is necessary, please call our customer service center. The use of unauthorized parts can create an unsafe conditions and environment**

**Connecting gas cylinder:**

The propane-gas supply cylinder to be used must be constructed and marked in accordance with the *Specifications for LP-gas Cylinders* of the U.S. Department of Transportation (DOT). Only cylinders marked "propane" must be used. Only use 1-pound (16.4 oz) cylinders equipped with a cylinder connection device compatible with the connection for outdoor cooking appliances. If the appliance is not in use, the gas cylinder must be disconnected. Storage of an appliance indoors is permissible ONLY if the cylinder is disconnected and removed from the appliance. Cylinders must be stored outdoors out of the reach of children and must not be stored in a building, garage, or any other enclosed area. Your cylinder must never be stored where temperatures can reach over 125°F! Before connection, be sure that there is no debris caught in the head of the gas cylinder, head of the regulator valve, or in the head of the burner and burner ports. Connect regulator valve and hand-tighten firmly. Disconnect the propane cylinder from the regulator valve when the grill is not in use. DO NOT obstruct the flow of combustion air and ventilation air to the grill.

**DANGER**

Never store a spare propane cylinder under or near this grill.  
Never refill disposable cylinder

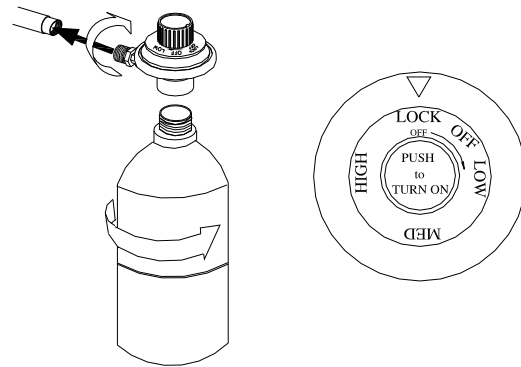

**Check for leaks. Make sure the regulator valve is securely fastened to the burner and the cylinder.**

**To check for leak**

Make 2-3 oz. (0-90ml) of leak solution by mixing one part liquid dishwashing soap with three parts water.  
Make sure control knobs are off.  
Spoon several drops of solution at the cylinder to regulator connection.  
Inspect the solution at the connection, looking for bubbles. If NO bubbles appear, the connection is secure.  
If bubbles appear, you have a leak.  
Disconnect regulator from tank and reconnect, making sure the connection is secure.  
Retest with solution. If you continue to see bubbles, replace the cylinder.

**Lighting your grill**

**Danger: Failure to open lid while igniting the barbecue’s burners, or not waiting 5 minutes to allow the gas to clear if the barbecue does not light, may result in an explosive flame-up which can cause serious bodily injury or death.**

**IMPORTANT:** Open lid during lighting grill. Attempting to light the burner with the lid closed may cause an explosion! Make sure there are no obstructions of airflow to the gas unit. Spiders and insects can nest within and clog the burner/venturi tube at the orifice. A clogged burner tube can lead to a fire beneath the appliance. Clean burner holes with a heavy-duty pipe cleaner. Make sure control knob is locked off. Turn gas supply “on” by connecting propane cylinder to regulator inlet fitting. Place a lighted match up through the hole in the side of the unit. Push and turn control knob to “high” setting. After lighting, please observe the burner flame, make sure all burner ports are lighted - a blue / yellow flame of 1-2 inches from the burner rod should appear (refer to drawing). If burner does not light after first try, turn the control knob to its “off” position and wait 5 minutes for gas to clear before trying again. If burner flame goes out during operation, immediately turn the gas “off” and open lid to let the gas clear for about 5 minutes. Attempt to re-light. Before cooking on this grill for the first time, operate the grill for about 15 minutes with the lid closed and the gas turned on “high.” This will “heat clean” the internal parts and dissipate odor from the painted finish. Clean your grill after each use, DO NOT use abrasive or flammable cleaners, as it will damage the parts of this product and may start a fire. Clean with warm soapy water.



5cm  
2.5cm  
0cm

**Observe Flame Height When lit:  
Flame should be a Blue / Yellow color Between 1” – 2” High**

## Cleaning and care

Caution: All cleaning and maintenance should be done when grill is cool and with the fuel supply turned off at the control dial and the propane cylinder disconnected. DO NOT clean any grill part in a self cleaning oven. The extreme heat will damage the finish.

### Cleaning

Burning-off the grill after every use (approx. 15 minutes) will keep excessive food residue from building up.

#### Recommended cleaning materials -

Mild dishwashing liquid detergent	Hot water
Nylon cleaning pad	Wire brush
Paper clip	Putty knife/scrapper
Compressed air	

DO NOT use cleaners that contain acid, mineral spirits or xylene.

#### Outside surfaces -

Use a mild dishwashing detergent and hot water solution to clean, then rinse with water.

If the inside surface of the grill lid has the appearance of peeling paint, baked on grease buildup has turned to carbon and is flaking off. Clean thoroughly with strong solution of detergent and hot water. Rinse with water and allow to completely dry.

Interior of grill bottom – Remove residue using brush, scraper and/or cleaning pad, then wash with dishwashing detergent and hot water solution. Rinse with water and let thoroughly dry.

Cooking Grids – The porcelain grates have a glass-like composition that should be handled with care not to chip. Use mild dishwashing detergent or baking soda and hot water solution. Non abrasive scouring powder can be used on stubborn stains, then rinse with water.

Heat Plate – Clean residue with wire brush and wash with soapy water, then rinse with water.

#### Cleaning the burner assembly -

1. Turn gas off at the control dial and disconnect cylinder
2. Remove cooking grates and heat plate.
3. Remove burner by removing screw from beneath burner "foot" using a screwdriver
4. Lift burner up and away from orifice
5. Clean inlet (venturi) of burner with small bottle brush or compressed air.
6. Remove all food residue and dirt on outside of burner surface.
7. Clean any clogged ports with a stiff wire (such as an opened paper clip)
8. Inspect burner for any damage (cracks or holes). If damage is found, replace with new burner. Reinstall burner; check to insure that gas valve orifice is correctly positioned inside burner inlet (venturi).

## **Award-Winning Barbecue Recipes**

### **Never-fail barbecue sauce**

#### **Ingredients:**

¼ cup	Finely Chopped Onion
2 tablespoons	Butter Or Margarine
¼ cup	Brown Sugar, Firmly Packed
1 tablespoon	Worcestershire Sauce
¼ teaspoon	Hot Pepper Sauce
1	Clove Garlic, Finely Chopped
1 cup	Catsup
¼ cup	Lemon Juice
1 teaspoon	Prepared Mustard

#### **Prepare:**

Cook onion and garlic in margarine until tender. Add remaining ingredients and bring to a boil. Simmer uncovered 15 to 20 minutes. Refrigerate leftovers after using.

### **Mamma's Marinated Chicken**

#### **Ingredients:**

¼ cup	Dijon mustard
2 tablespoons	Fresh lemon juice
1 ½ teaspoons	Worcestershire sauce
½ teaspoon	Dried tarragon
¼ teaspoon	Freshly ground black pepper
4	Boneless skinless chicken breast halves

#### **Prepare:**

Combine ingredients, mixing well. Marinate chicken for several hours. Grill uncovered, over medium heat, for 10 to 15 minutes or until juices run clear. Chicken is done when juices run clear.

### **Barbecued Honey Steak**

#### **Ingredients:**

5 pounds	Beef sirloin steak
2 tablespoons	Red pepper -- crushed
1 teaspoon	Black pepper
2	Garlic cloves -- crushed
1 large	Onion
1 cup	Honey

#### **Prepare:**

Combine all ingredients and marinate steak for 7-8 hours. Remove meat from marinade and grill over very high heat to desired doneness. Heat leftover marinade to a boil and pour over grilled steak to serve.

### **Hardcore Grilled Trout**

#### **Ingredients:**

1/4 cup	lemon or lime juice
2 tablespoons	melted butter
2 tablespoons	vegetable oil
2 tablespoons	chopped parsley
1 tablespoon	hot sauce
1/2 teaspoon	ground ginger
1/2 teaspoon	salt
4	brook trout -- about 1 pound each

#### **Prepare:**

Combine lemon juice, margarine, oil, parsley, sesame seeds, hot sauce, ginger and salt. Mix well. Pierce skin of fish in several places. Roll fish in juice mixture to coat inside and out. Cover. Refrigerate 30 minutes to 1 hour, turning occasionally. Remove fish from marinade. Place fish on grill; brush fish with marinade while grilling. Cook over high heat for 5 minutes. Turn; brush with marinade, cook 5 minutes longer. Fish is done when it flakes easily with fork.

### **Grilled Veggies**

#### **Ingredients:**

¼ cup	Olive oil
¼ cup	Red wine vinegar
1 teaspoon	Fresh rosemary
1 teaspoon	Fresh thyme leaves
1 teaspoon	Fresh basil; chopped
1 teaspoon	Fresh oregano; chopped
1 tablespoon	minced garlic
½ teaspoon	salt
½ teaspoon	Ground black pepper
2 pounds	assorted vegetables, chopped or whole, according to taste.

#### **Prepare**

Combine all ingredients in a small bowl. Marinate vegetables with sauce, and cover and refrigerate for 2 hrs. Grill vegetables over medium heat until tender, brushing them with marinade while they cook. Cooking times will vary according to the vegetables chosen.

## Gas Grill Troubleshooting

Problem	Possible Cause	Prevention/Cure
Burner will not light with match	No gas flow	Check if propane cylinder is empty. If propane cylinder is not empty, refer to "Sudden drop in gas flow (reduced flame height) If empty, replace cylinder
	Obstruction of gas flow.	Clear burner tubes.
	Disengagement of burner to orifice	Reengage burner and orifice
	Spider webs or insect nest in venturi.	Clean venturi.
	Burner ports clogged or blocked.	Clean burner ports.
Sudden drop in gas flow or reduced flame height.	Out of gas.	Check for gas in propane cylinder
Irregular flame pattern, flame does not run the full length of burner.	Burner ports are clogged or blocked	Clean burner ports.
Flame is yellow or orange.	New burner may have residual manufacturing oils.	Burn grill for 15 minutes with the lid closed
	Spider webs or insect nest in venturi.	Clean venturi.
	Food residue, grease or seasoning Salt on burner.	Clean burner.
	Poor alignment of orifice to burner venturi.	Assure burner venturi is properly engaged with orifice
Flame blow out	High or gusting winds	Turn front of grill to face wind or increase flame height.
	Low on propane gas.	Replace propane cylinder
Flare-up	Grease buildup.	Clean grill.
	Excessive fat in meat.	Trim fat from meat before grilling.
	Excessive cooking temperature.	Adjust (lower) temperature accordingly.
Persistent grease fire.	Grease trapped by food buildup around burner system.	Turn knob to OFF. Disconnect propane cylinder Leave lid in closed position and let fire burn out. After grill cools, remove and clean all parts.
Flashback [fire in burner tube(s)]	Burner and /or burner tube is blocked.	Clean burner and/or burner tube

## One Year Limited Warranty

---

- Burner, die cast top lid, black porcelain wire cooking grid, chrome plated warming grid, die cast bowl, bakelite handle, porcelain heating plate, and all other parts are warranted against defects in material and workmanship for one year.

### **The warranty is nontransferable.**

- It does not cover failures due to misuse or improper installation or maintenance.
- The warranty is for replacement or repair of defective parts only. Manufacturer will not be responsible for incidental or consequential damages or any labor costs.
- This limited warranty does not cover damage due to chipping and scratching of porcelain or painted surfaces nor does it cover corrosion or discoloring due to misuse, lack of maintenance, hostile environment, accidents, alterations, abuse or neglect.
- This limited warranty does not cover any scratches, dents, corrosion or discoloring caused by heat, abrasive or chemical cleaners nor chipping on porcelain enamel parts, nor any components used in the installation of the gas grill.

**Inability to provide proof of purchase or after the warranty has expired, customers will be subject to parts, shipping and handling fees.**

**Some states do not allow the limitation or exclusion of incidental or consequential damages, so the above limitations or exclusions may not apply to you. This warranty gives you specific legal rights, and you may also have other rights that vary from state to state.**

**For warranty claims or questions related to the product, please call our service center at 1-877-885-8227, 6:00AM to 5:00PM (PST). Monday through Friday.**

## **Manufactured by :**

Lucas Innovation Inc.

Xieken District, QingXi Town,  
Dong Guan, Guang Dong, China.