

This Owner's Manual is provided and hosted by [Appliance Factory Parts](#).



HONEYWELL HFD-130 Owner's Manual

[Shop genuine replacement parts for HONEYWELL
HFD-130](#)



[Find Your HONEYWELL Air Cleaner Parts - Select From 215 Models](#)

----- Manual continues below -----

Honeywell



IFD™ HIGH PERFORMANCE AIR PURIFIER

Model HFD-135

IMPORTANT SAFETY INSTRUCTIONS

READ AND SAVE THESE SAFETY INSTRUCTIONS BEFORE USING THIS AIR PURIFIER

When using electrical appliances, basic precautions should always be followed to reduce the risk of fire, electric shock, and injury to persons, including the following:

1. Read all instructions before operating the air purifier.
2. Place air purifier where it is not easily knocked over by persons in the household.
3. Always turn the air purifier to the **OFF** position and unplug from the wall outlet when not in use.
4. To disconnect the air purifier, first press the Power (⏻) button to turn the air purifier off, grip the plug and pull it from the wall outlet. Never pull by the cord.
5. Do not use any product with a damaged cord or plug or if product malfunctions, is dropped or damaged in any manner. Keep the cord away from heated surfaces.
6. Do not use air purifier outdoors.
7. Never use air purifier unless it is fully assembled.
8. Do not run power cord under carpets, and do not cover with throw rugs. Arrange cord such that it will not be tripped over.
9. Do not use air purifier where combustible gases, vapors or an oxygen rich environment are present.
10. Do not expose the air purifier to rain, or use near water, in a bathroom, laundry area or other damp location.
11. The air purifier must be used in its upright position.
12. Do not allow foreign objects to enter ventilation or exhaust opening as this may cause electric shock or damage to the air purifier. Do not block air outlets or intakes.
13. Locate air purifier near the outlet and avoid using an extension cord.
14. This appliance has a polarized plug (one blade is wider than the other). To reduce the risk of shock, this plug is intended to fit only one way in a polarized outlet. If the plug does not fit fully in the outlet, reverse the plug. If it still does not fit, contact a qualified electrician. **DO NOT** attempt to defeat this safety feature.
15. A loose fit between the AC outlet (receptacle) and plug may cause overheating and a distortion of the plug. Contact a qualified electrician to replace loose or worn outlet.
16. Do not sit, stand or place heavy objects on the air purifier.
17. Disconnect power supply before servicing.

WARNING: To Reduce the risk of fire or electric shock, do not use this air purifier with any solid-state speed control device.

The sealed UV bulbs contain a small amount of mercury. Dispose of these items at household hazardous waste collection sites only. If the UV bulb breaks, do not vacuum or handle with your bare hands.

INTRODUCTION

Thank you for purchasing the Honeywell IFD™ High Performance Air Purifier with a breakthrough technology in air purification. Please read below on how to operate and care for your new air purifier.

YOUR IFD™ AIR PURIFIER

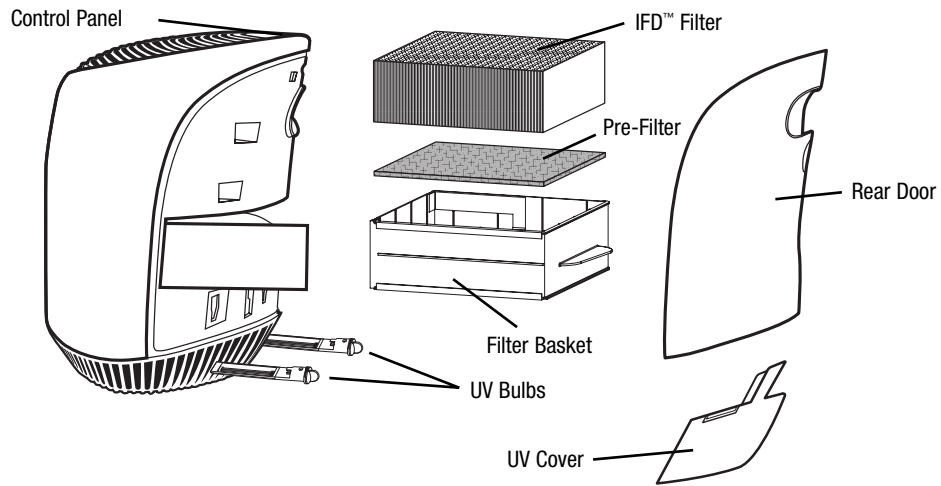

SET-UP

- Select a firm, level and flat location. For proper air flow, locate the unit at least 3 feet (1 M) from any wall or furniture.
- Ensure the exit grill faces away from the closest wall or furniture.
- Ensure no grilles are blocked.
- Plug into a grounded 120V outlet. See IMPORTANT SAFETY INSTRUCTIONS.

OPERATION

- Ensure the air purifier is plugged into a working outlet.
- Touch the Power (⏻) button to turn the air purifier On. The LCD screen will display the current setting. (Fig. 2).
- When first starting the unit, you can hear a change in speed and this is normal.
- To change speeds, press the up (⏮+) or down (⏭-) buttons. The display will indicate the current setting: Low (🌀), Medium (🌀), High (🌀).
- For best results, set the unit to operate at High (🌀) speed. For quieter settings, or during sleep, set the unit to Medium (🌀) or Low (🌀).
- Note that during normal operation, the rotating continuous operation symbol (⦿) will appear in place of timer hours.
- To turn the unit off, touch the Power (⏻) button.

Timer Operation

Once the air purifier is turned on, you can program this unit to turn off automatically after a set amount of time.

- Press the Timer button – the LCD screen flashes the number 18 (Fig. 3).
- Press the timer plus (+⏮) or timer minus (⏭-) buttons to increase or decrease the desired number of hours (1 to 18). The selected number will flash for a few seconds – once it stops flashing, the air purifier is in Timer mode.

(Example: If you want the unit to turn off in 6 hours, touch the Timer button, then press the timer minus (⏭-) button until the number "6" is displayed.)

- The Timer button will be illuminated in Timer mode and the number of hours remaining will be displayed.
- To turn the Timer mode off, press the Timer button. The continuous operation icon (⦿) will appear.

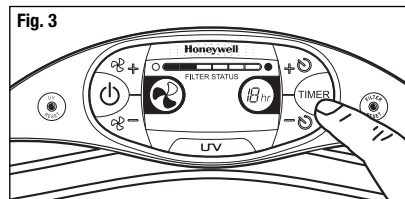
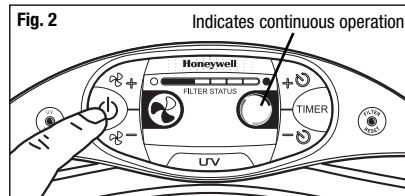
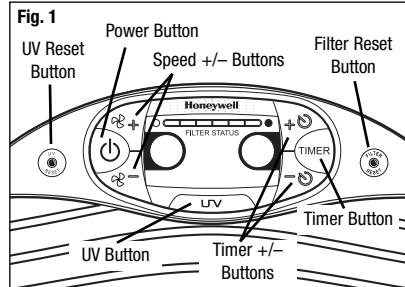

DUAL UV LAMP OPERATION

- Press the UV button to turn the Lamps on or off (Fig. 4).
- The Lamps will light and you will see a faint blue glow along the top grille of the unit. This is a visual effect. The UV bulbs are located in the lower portion of the unit.
- The UV button will be illuminated on the control panel.

NOTE: Removing the IFD™ filter assembly or UV cover or turning the unit off will cancel the UV Lamp function.

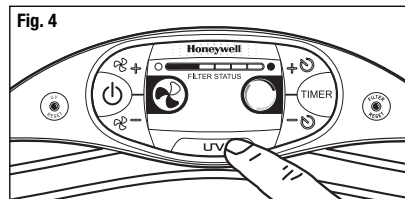

REMOVING / CLEANING THE IFD™ FILTER

This IFD™ air purifier is equipped with an electronic filter indicator to serve as a convenient guideline for cleaning the IFD™ and pre-filter based on the air purifier's hours of use and operating power level. This is beneficial because a filter's life depends on the amount of air and contaminants drawn through it. As you operate your IFD™ Air Purifier, the filter bar indicator will fill-up from left to right. The bar will continue to fill as you use the unit. Once the bar is completely full, the Filter Reset button will illuminate – it is time to clean the filters and reset the filter indicator.

To reset the filter clean indicator:

- With the power on, press and hold the Filter Reset button for 10 seconds, or until the filter bar clears itself (Fig. 5).

NOTE: Depending upon your individual usage (environment, hours and power level of operation), you may need to check and clean the filters more or less frequently.

To remove the IFD™ filter:

- Make certain that the air purifier is OFF and the unit is unplugged.
- Remove the rear door panel by turning the rear knob counter-clockwise and lifting the panel out and up.
- Gently tug the filter basket door towards you – the basket will first rotate and then slide out of the unit (Fig. 6).
- Continue to slide the basket and remove from the filter swing arm (Fig. 7).
- Take the IFD™ filter out of the filter basket and clean the filter (Fig. 8).

To clean the IFD™ filter:

- After removing the IFD™ Filter from the air purifier, gently run a vacuum cleaner with a nozzle or brush attachment along the filter to pick-up tiny particles (Fig. 9). Repeat on both sides.

If your IFD™ filter appears to have dirt that has not been removed by vacuuming, please follow the steps below to wash the IFD™ filter.

- Turn the power off and unplug the air purifier.
- Remove the IFD™ filter from the unit.
- Fill the sink with lukewarm water and add a few drops of mild dish soap (Fig. 10).
- Gently swish the filter in the soap solution to clean.
- Soak the filter for 2-3 minutes. Do not leave for an extended period of time.
- Rinse the filter with clean tap water.
- Shake the filter to remove any excess water (Fig. 11).
- Place the filter with the honeycomb side down on a plush towel.
- **Note that the filter may still be discolored even after washing.** This is acceptable and will not affect performance.
- Allow the IFD™ filter to dry for a few hours or overnight.
- When the IFD™ filter is **completely dry**, place back into the air purifier.

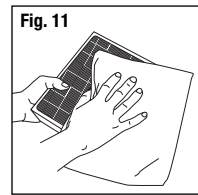
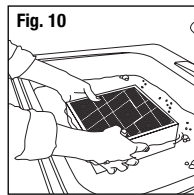
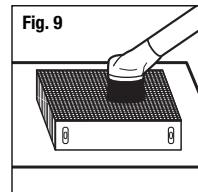
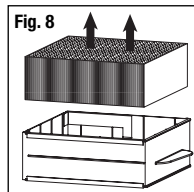
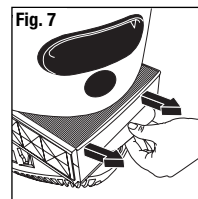
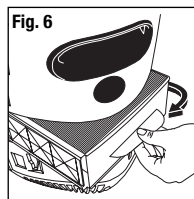
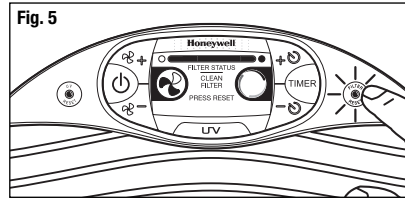

REMOVING / CLEANING THE IFD™ FILTER (CONTINUED)**CAUTION:**

- **Never place a wet IFD™ filter in your air purifier.**
- The IFD™ Filter is NOT dishwasher safe. Do not place the IFD™ filter in a dishwasher or subject it to other extreme hot water conditions.
- Do not use any solvents, strong cleaning agents or flammable liquids to clean the IFD™ filter.

Resetting the Filter Clean Indicator

After cleaning the IFD™ filter, you need to reset the filter monitor.

- Once the IFD™ filter has been checked and cleaned, the filter monitor will need to be reset.
- With the air purifier unit powered on, press and hold the filter reset button for approximately 10 seconds or until the LCD display is clear.

CLEANING THE PRE-FILTER

The particle pre-filter helps pick-up large airborne particles that enter the filter. The pre-filter can be removed and rinsed by hand under warm water. Let the pre-filter dry **completely** before inserting it back into the unit.

REPLACING THE ULTRAVIOLET (UV) LAMPS

The UV Reset LED light will illuminate when it is time to replace the dual UV bulbs. “Replace UV Bulb” will also appear in the control panel.

- Be sure to turn off and unplug your air purifier.
- Remove the UV cover (Fig. 12).
- Turn the UV bulb tab towards the unlock symbol (🔓) (Fig. 13).
- Gently grasp the top of the tab and pull the bulb cartridge straight out of the UV socket (Fig. 14). Do not touch the bulb directly with your hands.
- Do the same for the other bulb and pull the bulb cartridge out of the UV socket.
- Replace the left and right UV bulb sockets with new UV lamps (part number **135UV**).
- Discard old UV bulb cartridge(s) only at household hazardous waste collection sites.
- Place UV cover back in to its place until it clicks in position.
- Plug the air purifier back into an electrical socket and turn the air purifier on.
- Press and hold the UV Reset button for 10 seconds to clear the red LED light and “Replace UV Bulb” message (Fig. 15).

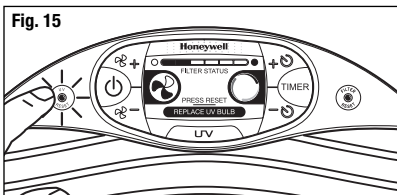
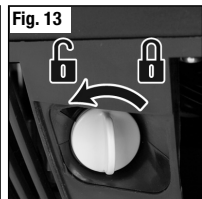
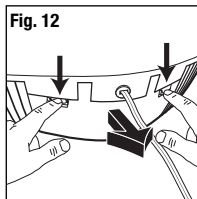

NOTE: Bulb and bulb housing are not intended for use with any other product or purpose.

NOTE: This unit is equipped with a safety interlock. The unit will not operate while the UV cover is removed.

INSTALLING THE FILTERS

Please make certain that the unit is OFF and unplugged.

To install the IFD™ Filter and pre-filter:

- Insert the pre-filter into the basket first.
- Place the IFD™ filter on top of the pre-filter, making certain that the insert arrows match up with the label outside the basket (Fig. 16).
- Slide the filter basket onto the swing arm and gently push the filter basket into the air purifier until it clicks into place.
- Replace the rear panel door by lining up the tabs on the bottom portion of the door with the notches on the air purifier and then turning the locking knob clockwise (Fig. 17).
- Turn the locking knob clockwise to lock in place (Fig. 18).

NOTE: This unit is equipped with a safety interlock. The unit will not operate while the Rear Door is removed.

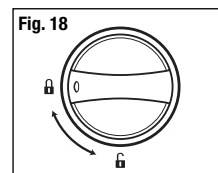
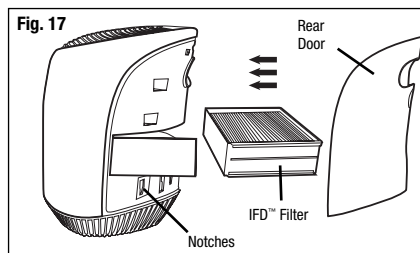
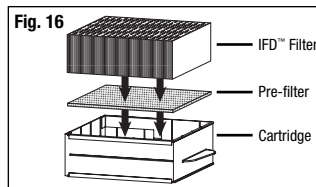

CLEANING AND MAINTENANCE

- Use a clean, dry cloth to wipe the external surfaces of the air purifier. DO NOT USE WATER, GASOLINE, POLISH, OR ANY CHEMICAL SOLUTION.
- The IFD™ filter and pre-filter should be cleaned at least once a month, or sooner depending on the air quality of the room (See "Removing/Cleaning the IFD™ Filter" or "Cleaning the Pre-Filter" respectively).

FREQUENTLY ASKED QUESTIONS

How often is cleaning required?

The IFD™ filter reset light will illuminate to indicate that the IFD™ filter should be cleaned. We recommend cleaning the filter about once a month depending on the air quality of the room.

I just cleaned my filter but the filter indicator bar is still showing it is dirty, what's wrong?

Each time you clean your filter you must reset the filter life indicator. It is a timer driven indicator to be used as a guideline, but does not represent the actual amount of dirt in the IFD™ filter. Press and hold the appropriate button for up to 10 seconds and when you let go, the filter indicator bar should be reset.

The filter indicator bar on my unit is completely full but my filter doesn't really look dirty.

The filter indicator on your unit is timer-based and does not measure the amount of particles in the IFD™ filter. It is possible that your filter indicator could indicate that the filter is dirty but some particles are so small that they cannot be seen but are present in the filter. We recommend cleaning the IFD™ filter (see *Removing/Cleaning the IFD™ Filter* in the manual).

FREQUENTLY ASKED QUESTIONS (CONTINUED)

My filter bar says my filter is still relatively clean but when I checked my filter it was really dirty.

In conditions where smoke, pets or air with a lot of contaminants are present it is possible that the filter could be dirty sooner than indicated on the indicator. The filter life indicator on your unit runs on a timer and if there are more particles in your air than in an average home, your filter could capture airborne particles sooner than indicated on the display. The indicator is intended to be used as a guideline and individual environmental conditions will vary.

My unit will not turn on.

The air purifier has a safety feature to ensure that all the covers are in place. The rear cover or the UV cover may not be installed correctly. Check to make sure the rear cover is installed flush with the unit and is locked. Check that the UV cover is flush with the unit and is snapped into place.

When do the UV bulbs need to be replaced?

The "Replace UV Bulb" message and light will turn on after 6 months of continuous use, so the bulbs should be replaced at this time.

Is the IFD™ Air Purifier considered an ozone generator?

No. Ozone generators produce large amounts of ozone and the EPA considers these unsafe for household use.

REPLACEMENT FILTERS / UV BULBS

To order a replacement pre-filter for the IFD™ Air Purifier model HFD-135, visit our website at www.kaz.com or call us at 1-800-477-0457.

Washable Pre-Filter #60007: \$6.25

Replacement UV bulbs (2-pack), model number 135UV: \$44.99

IMPORTANT NOTE

The ionizing process used by the air purifier produces small amounts of ozone as a byproduct. The air purifier complies with U.S. Government limits for acceptable levels of ozone (less than 50 parts per billion by volume of air circulating through the product). People with a history of respiratory problems or heart/lung disease should consult a physician prior to using this product.

CONSUMER RELATIONS

Mail questions or comments to:
Kaz, Inc.
Consumer Relations Dept.
250 Turnpike Road
Southborough, MA 01772

Call us toll-free at: 1-800-477-0457
E-mail: consumerrelations@kaz.com

Or visit our website at: www.kaz.com

Please be sure to specify a model number.

NOTE: IF YOU EXPERIENCE A PROBLEM, PLEASE CONTACT CONSUMER RELATIONS FIRST OR SEE YOUR WARRANTY. DO NOT RETURN TO THE ORIGINAL PLACE OF PURCHASE. DO NOT ATTEMPT TO OPEN THE MOTOR HOUSING YOURSELF, DOING SO MAY VOID YOUR WARRANTY AND CAUSE DAMAGE TO THE AIR PURIFIER OR PERSONAL INJURY.

5 YEAR LIMITED WARRANTY

YOU SHOULD FIRST READ ALL INSTRUCTIONS BEFORE ATTEMPTING TO USE THIS PRODUCT.

- A. This 5 year limited warranty applies to repair or replacement of product found to be defective in material or workmanship. This warranty does not apply to damage resulting from commercial, abusive, unreasonable use or supplemental damage. Defects that are the result of normal wear and tear will not be considered manufacturing defects under this warranty.

KAZ IS NOT LIABLE FOR INCIDENTAL OR CONSEQUENTIAL DAMAGES OF ANY NATURE. ANY IMPLIED WARRANTY OF MERCHANTABILITY OR FITNESS FOR A PARTICULAR PURPOSE ON THIS PRODUCT IS LIMITED IN DURATION TO THE DURATION OF THIS WARRANTY.

Some jurisdictions do not allow the exclusion or limitation of incidental or consequential damages or limitations on how long an implied warranty lasts, so the above limitations or exclusions may not apply to you. This warranty gives you specific legal rights, and you also may have other rights which vary from jurisdiction to jurisdiction. This warranty applies only to the original purchaser of this product from the original date of purchase.

- B. At its option, Kaz will repair or replace this product if it is found to be defective in material or workmanship. Defective product should be returned to the place of purchase in accordance with store policy. Thereafter, while within the warranty period defective product may be returned to Kaz.

- C. This warranty does not cover the IFD™ filter or pre-filter except for material or workmanship defects.
- D. This warranty does not cover damage resulting from any unauthorized attempts to repair or from any use not in accordance with the instruction manual.
- E. Return defective product to Kaz, Inc. with a brief description of the problem. Include proof of purchase and a \$10 US/\$15.50 CAN check or money order for handling, return packing and shipping charges. Please include your name, address and a daytime phone number. You must prepay shipping charges. Send to:

In U.S.A.:

Kaz, Inc.
Attn: Returns Department
4755 Southpoint Drive
Memphis, TN 38118
USA

In Canada:

Kaz, Inc.
Attn: Returns Department
510 Bronte Street South
Milton, ON L9T 2X6
Canada