

Model QL50E-IC

Catalog 9254210
(16 Gal.)

shop-vac®

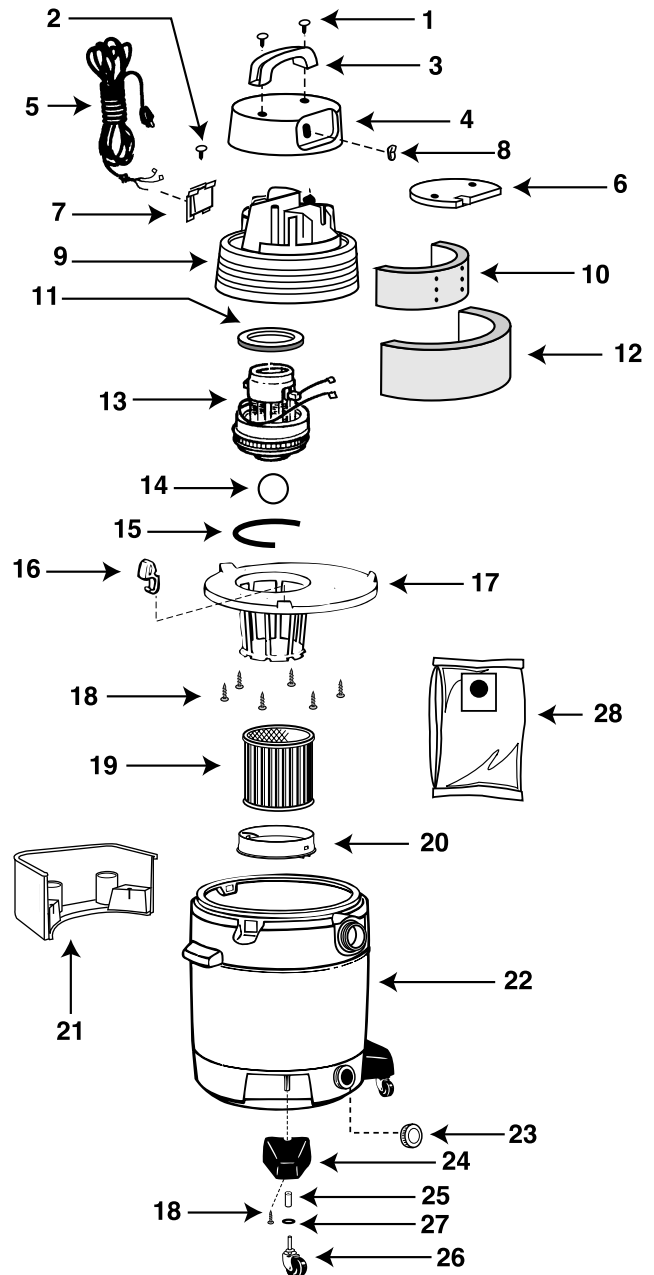

ITEM	DESCRIPTION	PART NO.
1	Screw Truss Head 1/4" x 3/4" Type AB	1514699
2	Screw #8 x 1/2" Ph Pan Hd Type AB	1500799
3	Handle	2410500
4	Motor Housing Cover	2410603
5	Cord	2580023
6	Foam Insert Cover	2412500
7	Cord Retainer	2411112
8	Switch	8231800
9	Motor Housing	2410713
10	Foam Motor Housing - Inner	1290400
11	Gasket - Upper Motor	2072000
12	Foam Motor Housing - Outer	1290503
13	Motor	1496797
14	Ball Float	0081100
15	Strip Gasket	2071100
16	Lid Latch	8550101
17	Lid Cage & Latch Assembly	8988724
18	Screw Hex Head #10 x 3/4" Type AB	1503999
19	Cartridge Filter	9030462
20	Filter Retainer	3008000
21	Accessory Caddy	8564202
22	Tank Assembly	1046597
23	Drain Cap	1062020
24	Caster Foot	8565100
25	Caster Retainer	8565600
26	Caster	6773600
27	Flatwasher	0704399
28	Collection Bag	9067362

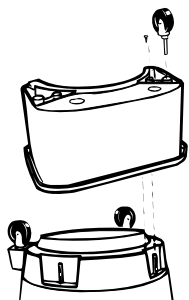

Install casters and caddy as follows:

1. With tank cover removed, invert tank so the bottom is facing up.
2. Insert two caster feet into adjacent slots at front of tank. Secure with screws.
3. Insert accessory caddy into remaining slots at back of tank. Secure with screws.
4. Insert casters into caddy and supports by inserting the caster stems into the holes provided and applying pressure until you feel the casters are firmly in place.

STANDARD ACCESSORIES

- 6' x 2 1/2" Locking hose
- 2 - 2 1/2" Extension wands
- 6" Utility nozzle
- 14" Floor nozzle
- 14" Squeegee insert
- 2 1/2" Crevice tool