



**LG**

<http://biz.lgservice.com>

# **SXS** REFRIGERATOR

## **SERVICE MANUAL**

### **CAUTION**

**PLEASE READ CAREFULLY THE SAFETY PRECAUTIONS OF THIS MANUAL  
BEFORE CHECKING OR OPERATING THE REFRIGERATOR.**

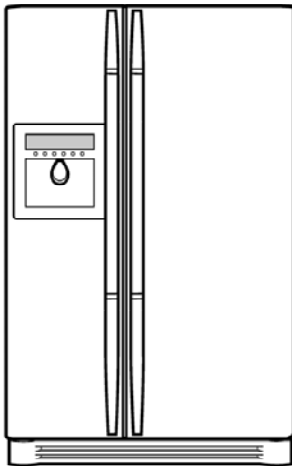

LRSC26944SW, LRSC26944TT  
LRSC26930SW, LRSC26930TT  
LRSC26922SW, LRSC26922TT  
LRSC26920SW, LRSC26920TT

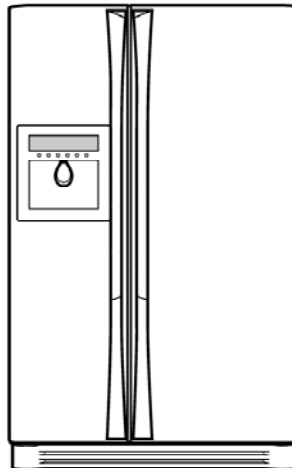

LRSC26911SW, LRSC26911TT  
LRSC26910SW, LRSC26910TT

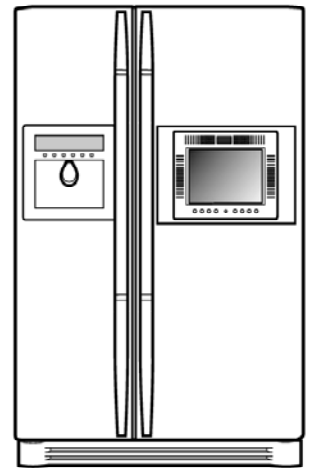

LRSC26980SB, LRSC26980TT

# CONTENTS

---

<b>WARNINGS AND PRECAUTIONS FOR SAFETY .....</b>	<b>3</b>
<b>SPECIFICATIONS.....</b>	<b>4</b>
<b>PARTS IDENTIFICATION.....</b>	<b>9</b>
<b>HOW TO INSTALL THE REFRIGERATOR .....</b>	<b>14</b>
HOW TO ADJUST DOOR HEIGHT.....	14
FILTER .....	15
HOW TO CONTROL THE ICEMAKER WATER SUPPLY .....	16
<b>MICOM FUNCTION .....</b>	<b>18</b>
<b>EXPLANATION OF MICOM CIRCUIT .....</b>	<b>32</b>
EXPLANATION OF PWB CIRCUIT.....	32
PWB PARTS DIAGRAM AND LIST.....	47
PWB CIRCUIT DIAGRAM .....	54
<b>OPERATION PRINCIPLE AND REPAIR METHOD OF ICEMAKER .....</b>	<b>56</b>
OPERATION PRINCIPLE.....	56
CONTROL METHOD ACCORDING TO FUNCTIONS.....	57
DEFECT DIAGNOSIS FUNCTION.....	59
<b>CIRCUIT .....</b>	<b>60</b>
<b>TROUBLE DIAGNOSIS.....</b>	<b>63</b>
TROUBLESHOOTING .....	63
FAULTS .....	73
COOLING CYCLE HEAVY REPAIR.....	90
HOW TO DEAL WITH CLAIMS .....	97
<b>HOW TO DISASSEMBLE AND ASSEMBLE .....</b>	<b>103</b>
DOOR.....	103
HANDLE .....	104
FAN SHROUD GRILLE .....	105
ICEMAKER ASSEMBLY.....	105
DISPENSER.....	106
<b>TV-RADIO .....</b>	<b>107</b>
<b>EXPLODED VIEW.....</b>	<b>113</b>
<b>REPLACEMENT PARTS LIST .....</b>	<b>131</b>

# WARNINGS AND PRECAUTIONS FOR SAFETY

---

Please observe the following safety precautions to use the refrigerator safely and correctly and to prevent accident or injury when servicing.

1. Be careful of an electric shock. Disconnect power cord from wall outlet and wait for more than three minutes before replacing PWB parts. Disconnect the power whenever replacing and repairing electric components.
2. If disconnecting the power, wait at least 5 minutes before plugging the unit back in.
3. Before touching the power cord, make sure the cord is not damaged. If the power cord is damaged, it can cause a fire or an electrical shock.
4. Make sure the unit has a dedicated circuit breaker. Overloading the circuit can cause a fire.
5. Please make sure the outlet is properly grounded. Particularly in a wet or damp area.
6. Use standard electrical components.
7. Remove dust and foreign materials from the housing and connecting parts.
8. Do not fray, damage, run over, kink, bend, pull out, or twist the power cord.
9. Please check for evidence of moisture intrusion in the electrical components. Replace the parts or mask with insulation tape if moisture intrusion is confirmed.
10. Stay clear of the icemaker with hands or tools if the unit has power. Do not try to manually turn the ice maker even when turned off.
11. Customers should not repair the refrigerator themselves. This work requires special tools and knowledge. Non-professionals could cause fire, injury, or damage to the product.
12. Do not store flammable materials such as ether, benzene, alcohol, chemicals, or gas in the refrigerator.
13. Do not put anything on top of the refrigerator, especially something containing water, like a vase.
14. Do not put glass bottles of water into the freezer. The contents will freeze and break the bottles.
15. If you scrap or discard the refrigerator, remove the doors and dispose of it where children are not likely to play in or around it.

# SPECIFICATIONS

Ref No. : LRSC26944\*\*

ITEMS	SPECIFICATIONS	ITEMS	SPECIFICATIONS
DIMENSIONS	908 x 896 x 1771 mm	DRIER	MOLECULAR SIEVE XH-7
W x D x H	(35 <sup>11</sup> / <sub>16</sub> X 35 <sup>5</sup> / <sub>16</sub> X 69 <sup>11</sup> / <sub>16</sub> in.)	CAPILLARY TUBE	ID Ø0.85
NET WEIGHT	149 kg (328.5 lbs.)	FIRST DEFROST	4 - 5 Hours
COOLING SYSTEM	Fan Cooling	DEFROST CYCLE	13 - 15 Hours
TEMPERATURE CONTROL	Micom Control	DEFROSTING DEVICE	Heater, Sheath
DEFROSTING SYSTEM	Full Automatic	ANTI-SWEAT HEATER	Dispenser Duct Door Heater
	Heater Defrost		Dispenser Heater
INSULATION	Cyclo-Pentane	ANTI-FREEZING HEATER	Water Tank Heater
COMPRESSOR	PTC Starting Type		Damper Heater
EVAPORATOR	Fin Tube Type	FREEZER LAMP	40W (2 EA)
CONDENSER	Wire Condenser	REFRIGERATOR LAMP	40W (4 EA)
REFRIGERANT	R134a (185g) (6 <sup>1</sup> / <sub>2</sub> oz.)	DISPENSER LAMP	15W (1 EA)
LUBRICATING OIL	FREOL @ 10G (320 cc)		

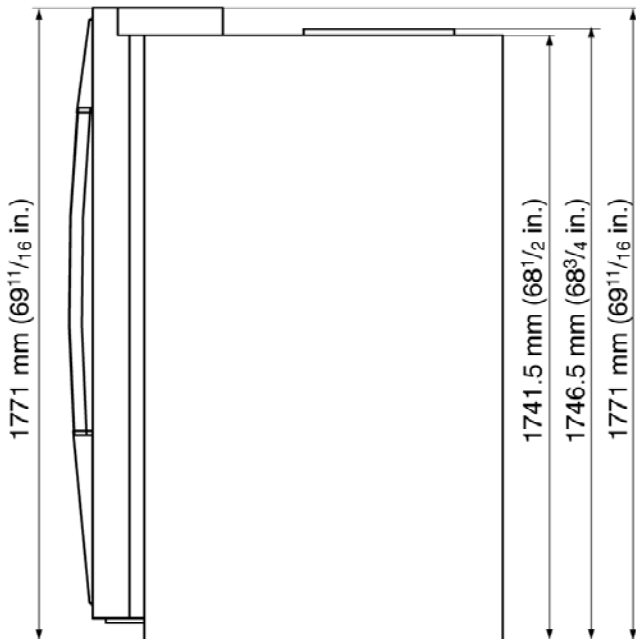

Front View

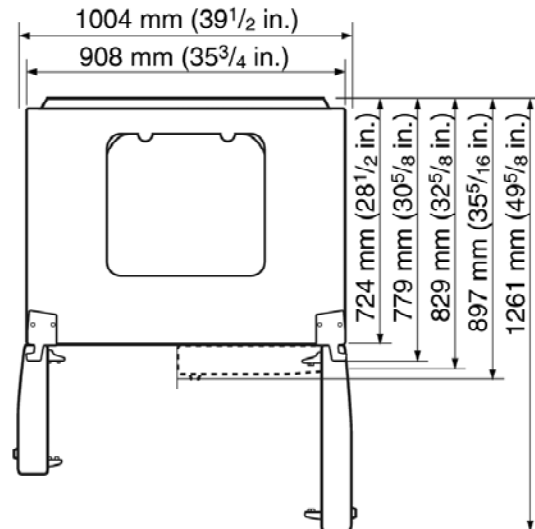

Top View

# SPECIFICATIONS

Ref No. : LRSC26930\*\*

ITEMS	SPECIFICATIONS	ITEMS	SPECIFICATIONS
DIMENSIONS	908 x 896 x 1771 mm	DRIER	MOLECULAR SIEVE XH-7
W x D x H	(35 <sup>11</sup> / <sub>16</sub> x 35 <sup>5</sup> / <sub>16</sub> x 69 <sup>11</sup> / <sub>16</sub> in.)	CAPILLARY TUBE	ID Ø0.85
NET WEIGHT	149 kg (328.5 lbs.)	FIRST DEFROST	4 - 5 Hours
COOLING SYSTEM	Fan Cooling	DEFROST CYCLE	13 - 15 Hours
TEMPERATURE CONTROL	Micom Control	DEFROSTING DEVICE	Heater, Sheath
DEFROSTING SYSTEM	Full Automatic	ANTI-SWEAT HEATER	Dispenser Duct Door Heater
	Heater Defrost		Dispenser Heater
INSULATION	Cyclo-Pentane	ANTI-FREEZING HEATER	Water Tank Heater
COMPRESSOR	PTC Starting Type		Damper Heater
EVAPORATOR	Fin Tube Type	FREEZER LAMP	40W (1 EA)
CONDENSER	Wire Condenser	REFRIGERATOR LAMP	40W (4 EA)
REFRIGERANT	R134a (185g) (6½ oz.)	DISPENSER LAMP	15W (1 EA)
LUBRICATING OIL	FREOL @ 10G (320 cc)		

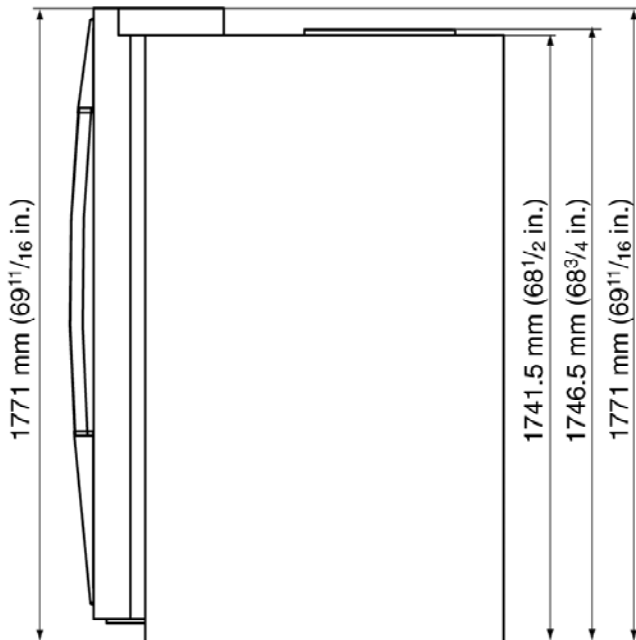

Front View

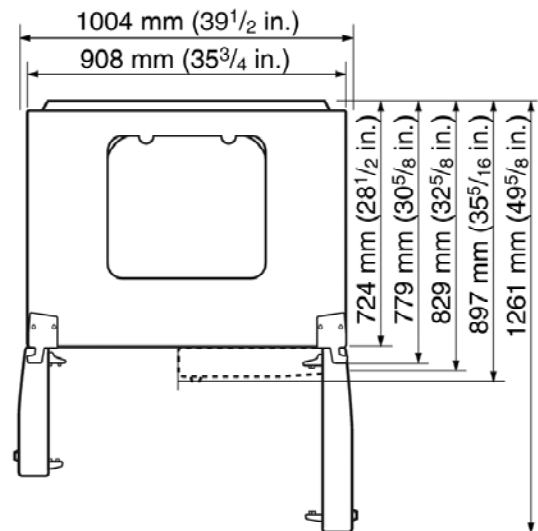

Top View

# SPECIFICATIONS

Ref No. : LRSC26920\*\*, LRSC26922\*\*

ITEMS	SPECIFICATIONS	ITEMS	SPECIFICATIONS
DIMENSIONS	908 x 896 x 1771 mm	DRIER	MOLECULAR SIEVE XH-7
W x D x H	(35 <sup>11</sup> / <sub>16</sub> x 35 <sup>5</sup> / <sub>16</sub> x 69 <sup>11</sup> / <sub>16</sub> in.)	CAPILLARY TUBE	ID Ø0.85
NET WEIGHT	149 kg (328.5 lbs.)	FIRST DEFROST	4 - 5 Hours
COOLING SYSTEM	Fan Cooling	DEFROST CYCLE	13 - 15 Hours
TEMPERATURE CONTROL	Micom Control	DEFROSTING DEVICE	Heater, Sheath
DEFROSTING SYSTEM	Full Automatic	ANTI-SWEAT HEATER	Dispenser Duct Door Heater
	Heater Defrost		Dispenser Heater
INSULATION	Cyclo-Pentane	ANTI-FREEZING HEATER	Water Tank Heater
COMPRESSOR	PTC Starting Type		Damper Heater
EVAPORATOR	Fin Tube Type	FREEZER LAMP	40W (1 EA)
CONDENSER	Wire Condenser	REFRIGERATOR LAMP	40W (4 EA)
REFRIGERANT	R134a (185g) (6½ oz.)	DISPENSER LAMP	15W (1 EA)
LUBRICATING OIL	FREOL @ 10G (320 cc)		

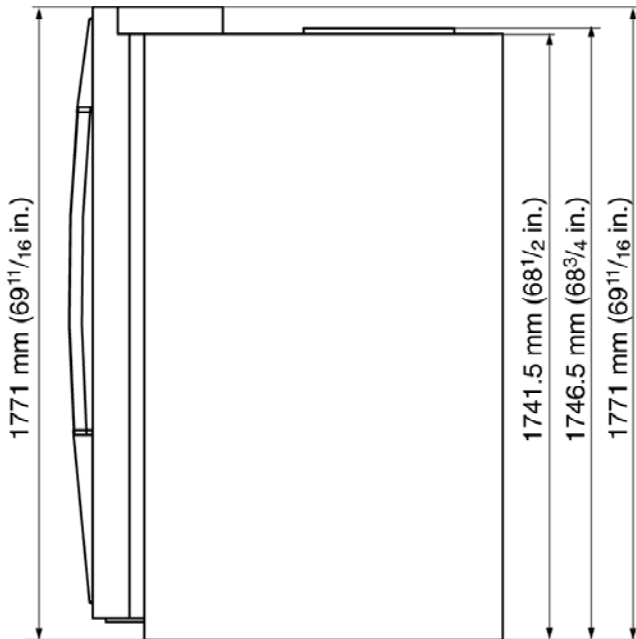

Front View

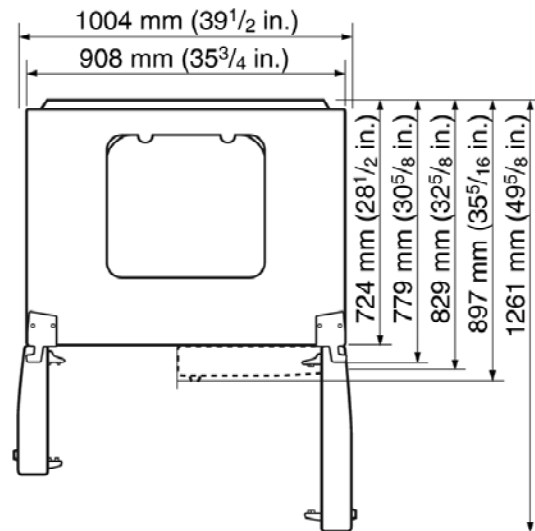

Top View

# SPECIFICATIONS

Ref No. : LRSC26910\*\*, LRSC26911\*\*

ITEMS	SPECIFICATIONS	ITEMS	SPECIFICATIONS
DIMENSIONS	908 x 896 x 1771 mm	DRIER	MOLECULAR SIEVE XH-7
W x D x H	(35 <sup>11</sup> / <sub>16</sub> x 35 <sup>5</sup> / <sub>16</sub> x 69 <sup>11</sup> / <sub>16</sub> in.)	CAPILLARY TUBE	ID Ø0.85
NET WEIGHT	149 kg (328.5 lbs.)	FIRST DEFROST	4 - 5 Hours
COOLING SYSTEM	Fan Cooling	DEFROST CYCLE	13 - 15 Hours
TEMPERATURE CONTROL	Micom Control	DEFROSTING DEVICE	Heater, Sheath
DEFROSTING SYSTEM	Full Automatic	ANTI-SWEAT HEATER	Dispenser Duct Door Heater
	Heater Defrost		Dispenser Heater
INSULATION	Cyclo-Pentane	ANTI-FREEZING HEATER	Water Tank Heater
COMPRESSOR	PTC Starting Type		Damper Heater
EVAPORATOR	Fin Tube Type	FREEZER LAMP	40W (1 EA)
CONDENSER	Wire Condenser	REFRIGERATOR LAMP	40W (3 EA)
REFRIGERANT	R134a (185g) (6½ oz.)	DISPENSER LAMP	15W (1 EA)
LUBRICATING OIL	FREOL @ 10G (320 cc)		

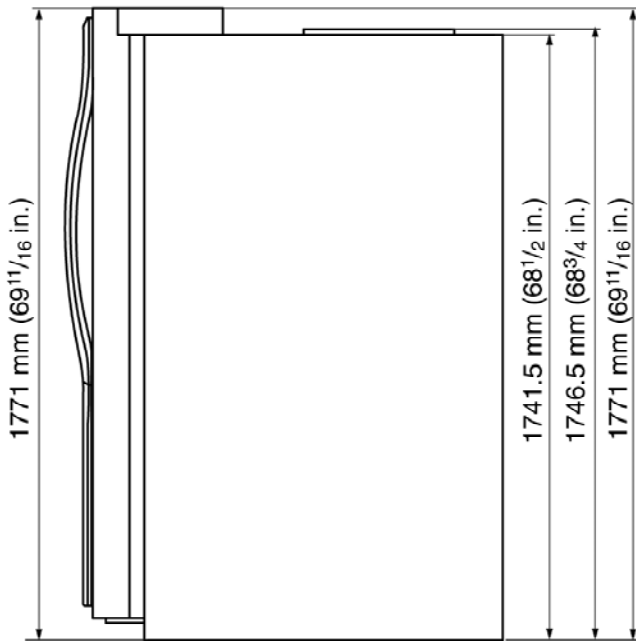

Front View

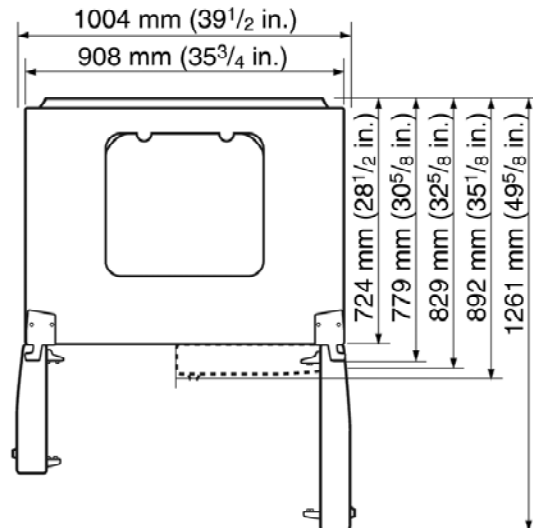

Top View

# SPECIFICATIONS

Ref No. : LRSC26980TT

ITEMS	SPECIFICATIONS	ITEMS	SPECIFICATIONS
DIMENSIONS	908 x 896 x 1771 mm	DRIER	MOLECULAR SIEVE XH-7
W x D x H	(35 <sup>11</sup> / <sub>16</sub> X35 <sup>5</sup> / <sub>16</sub> X69 <sup>11</sup> / <sub>16</sub> in.)	CAPILLARY TUBE	ID Ø0.85
NET WEIGHT	154 kg (339.5 lbs.)	FIRST DEFROST	4 - 5 Hours
COOLING SYSTEM	Fan Cooling	DEFROST CYCLE	13 - 15 Hours
TEMPERATURE CONTROL	Micom Control	DEFROSTING DEVICE	Heater, Sheath
DEFROSTING SYSTEM	Full Automatic	ANTI-SWEAT HEATER	Dispenser Duct Door Heater
	Heater Defrost		Dispenser Heater
INSULATION	Cyclo-Pentane	ANTI-FREEZING HEATER	Water Tank Heater
COMPRESSOR	PTC Starting Type		Damper Heater
EVAPORATOR	Fin Tube Type	FREEZER LAMP	40W (2 EA)
CONDENSER	Wire Condenser	REFRIGERATOR LAMP	40W (4 EA)
REFRIGERANT	R134a (185g) (6 <sup>1</sup> / <sub>2</sub> oz.)	DISPENSER LAMP	15W (1 EA)
LUBRICATING OIL	FREOL @ 10G (320 cc)		

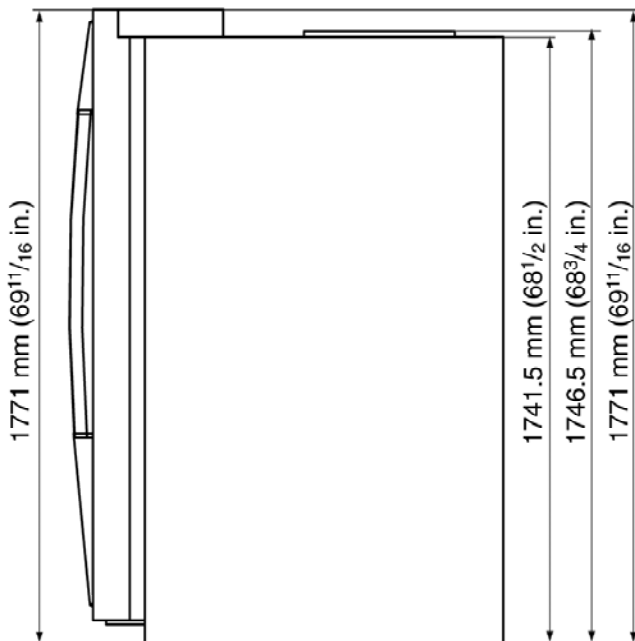

Front View

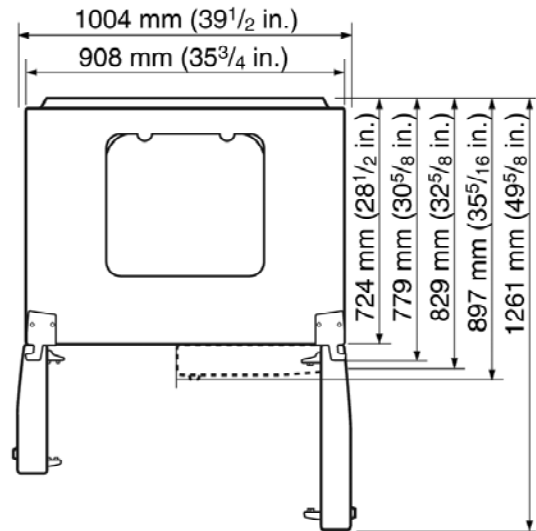

Top View



# PARTS IDENTIFICATION

Ref No. : LRSC26944\*\*

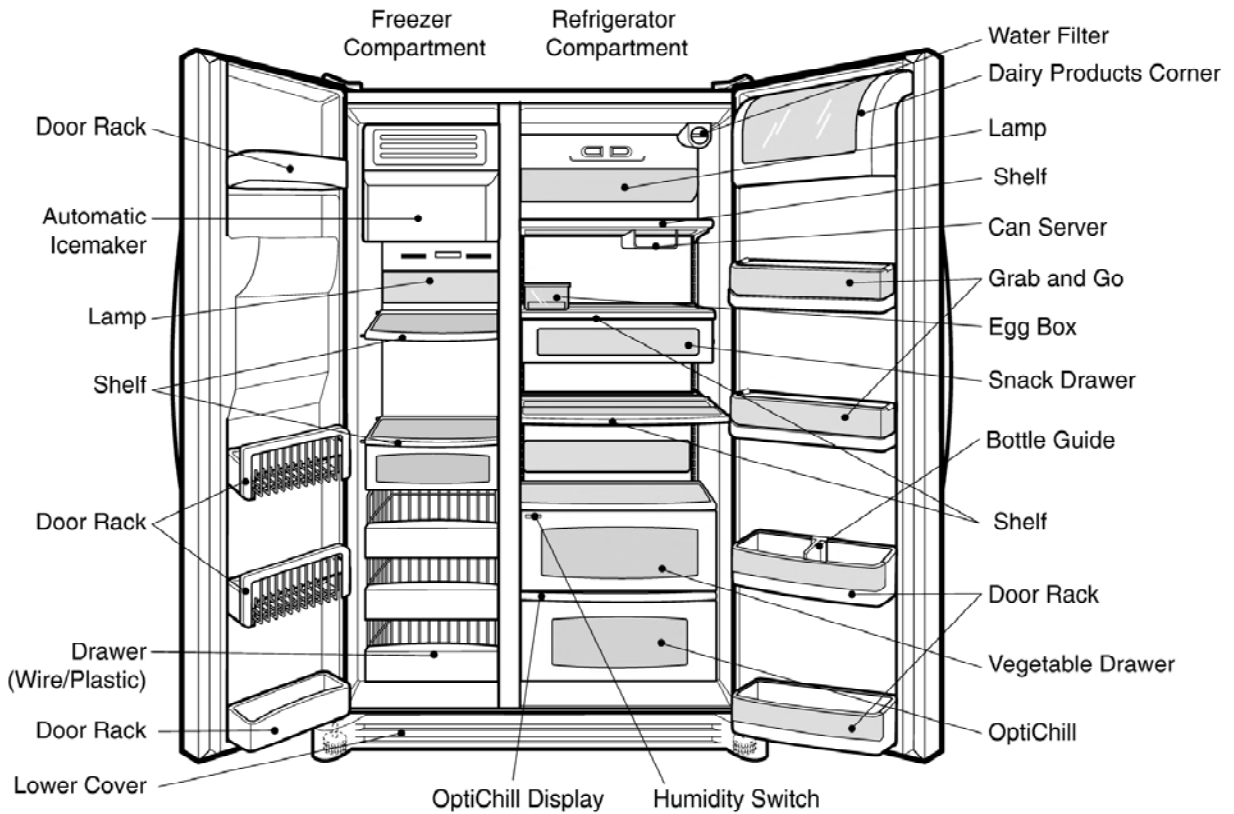
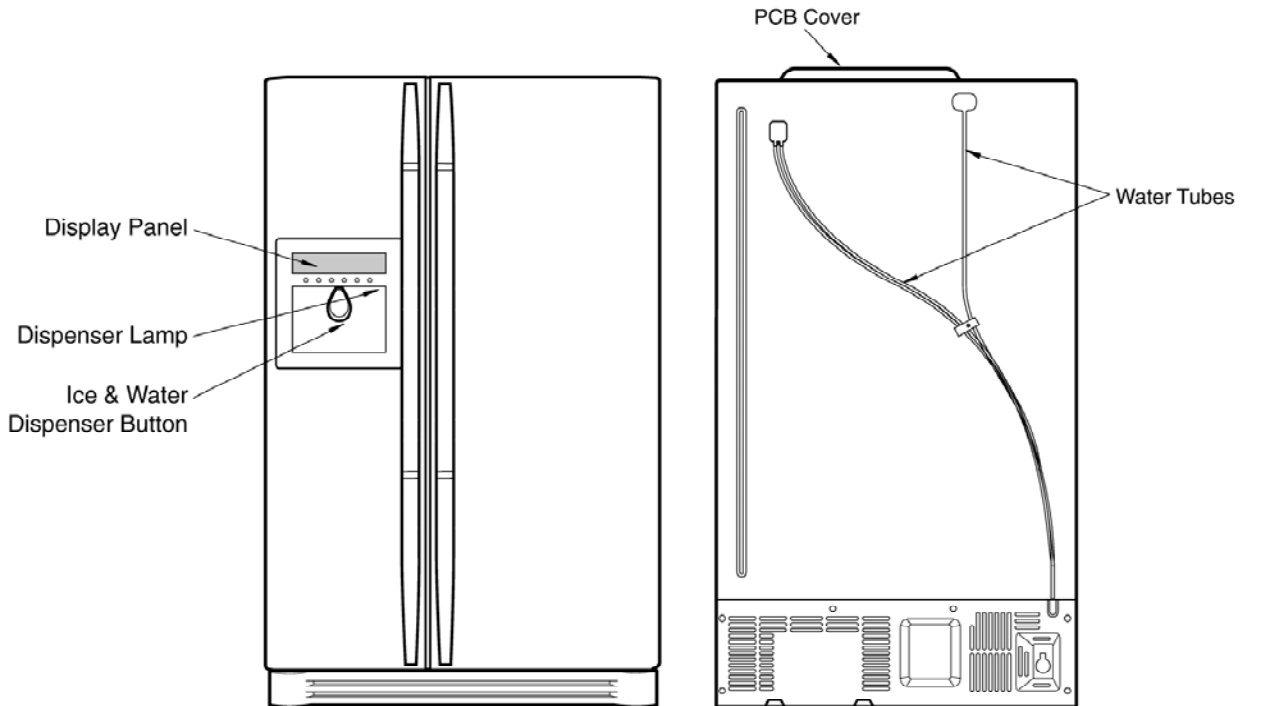

# PARTS IDENTIFICATION

Ref No. : LRSC26930\*\*

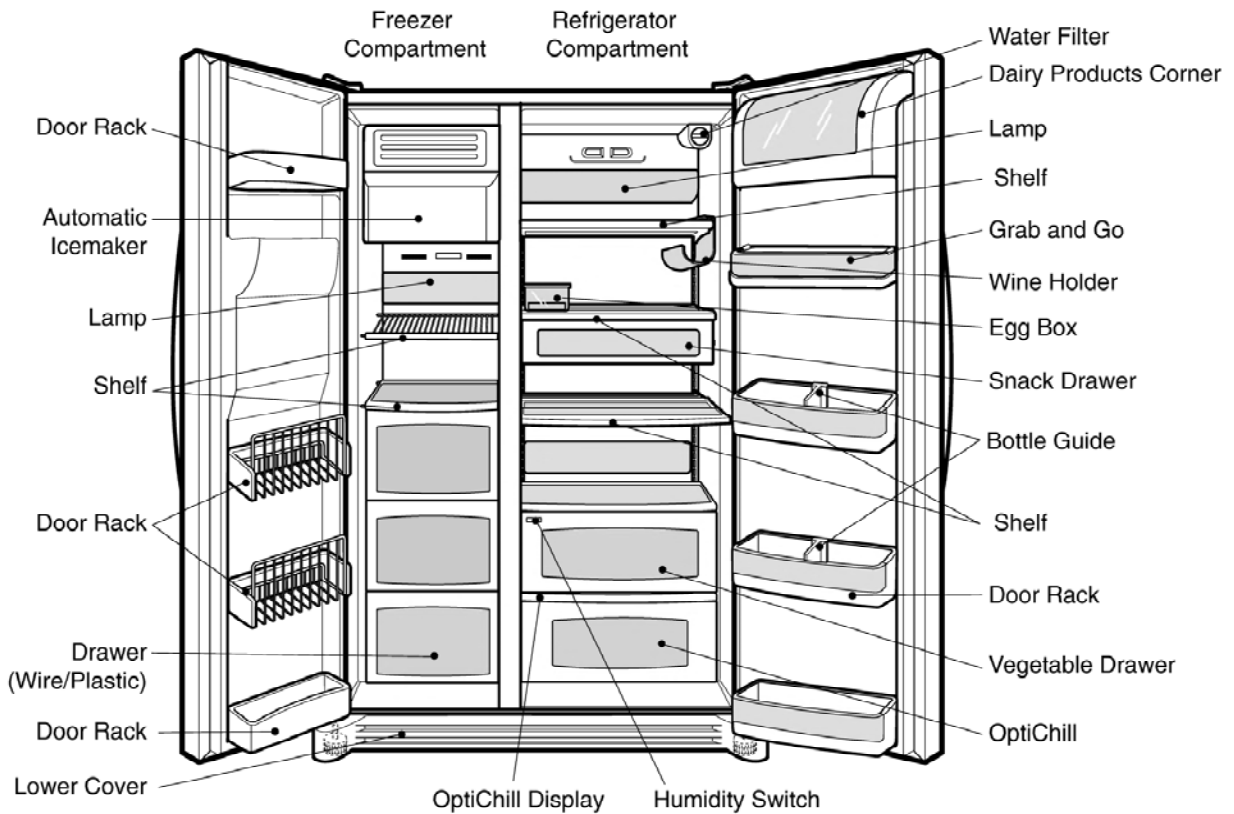
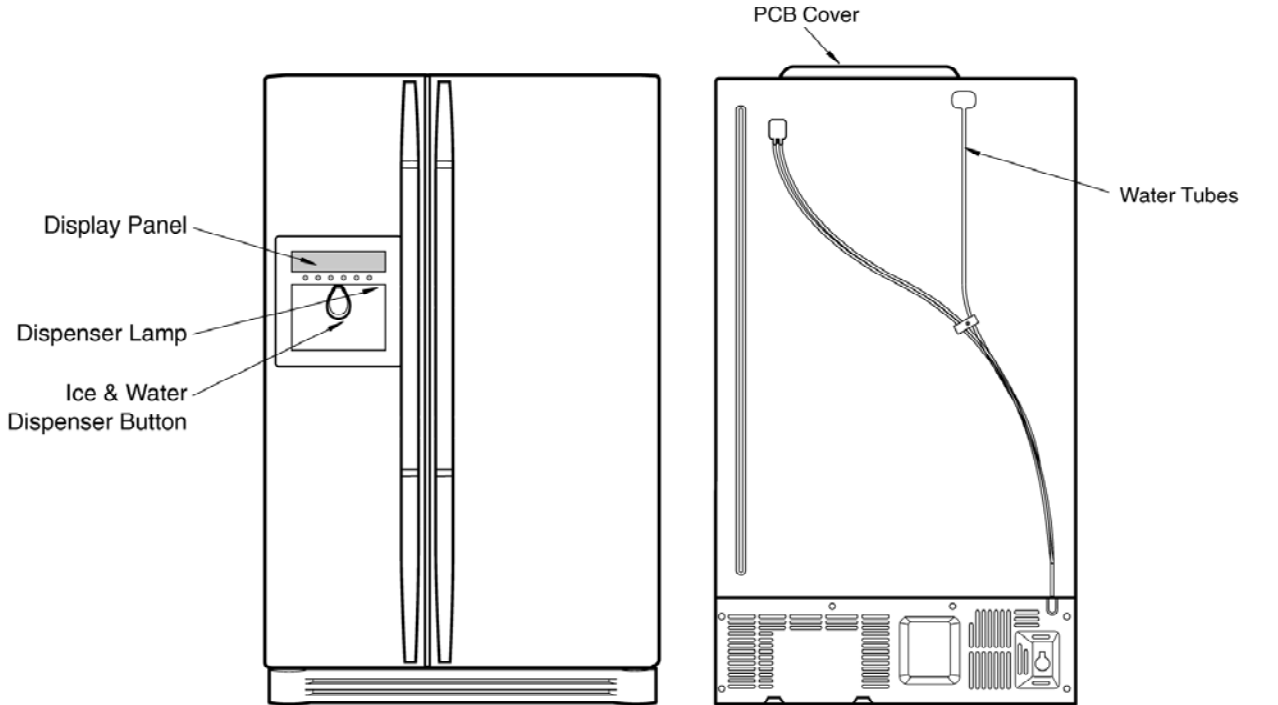

# PARTS IDENTIFICATION

Ref No. : LRSC26920\*\*, LRSC26922\*\*

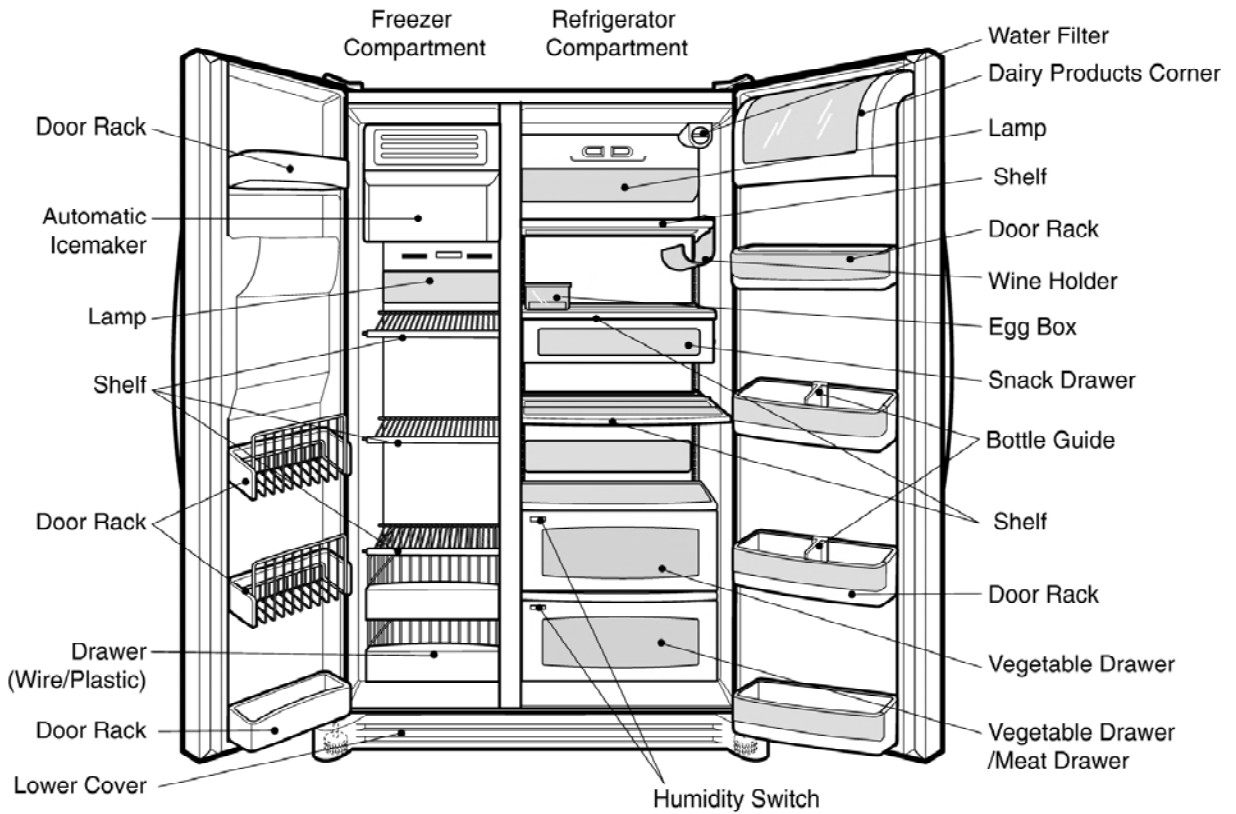
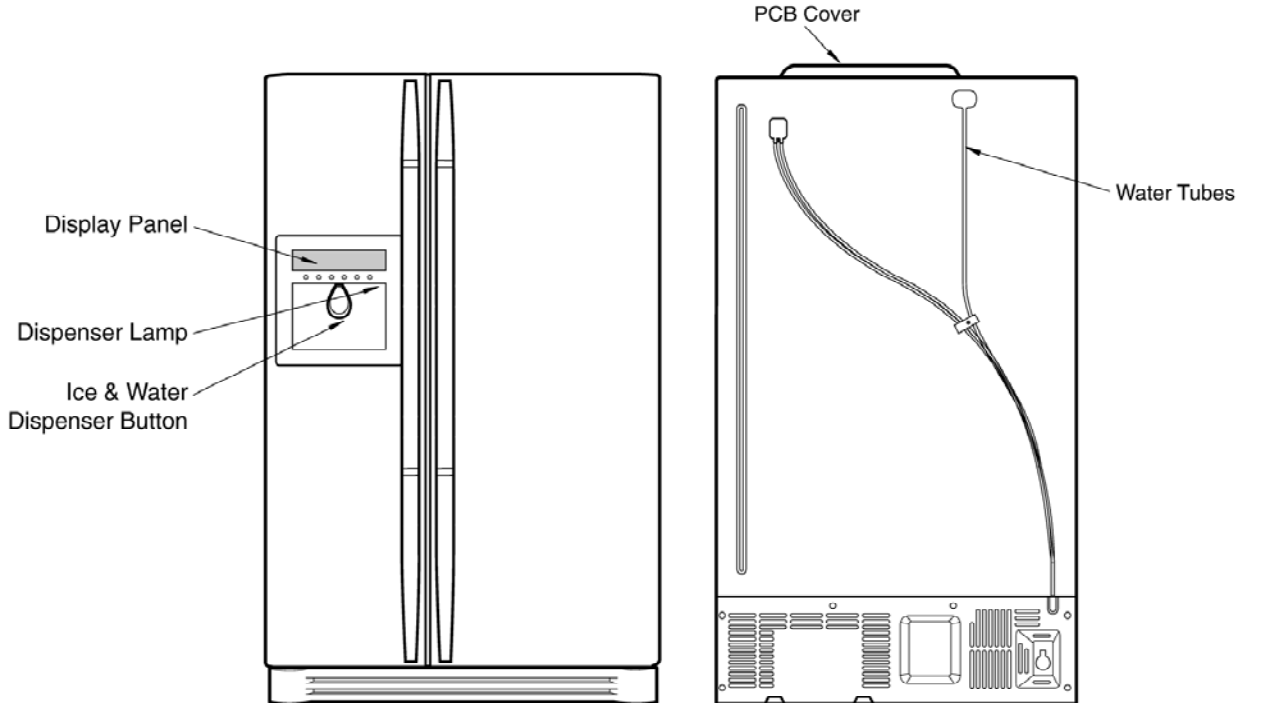

# PARTS IDENTIFICATION

Ref No. : LRSC26910\*\*, LRSC26911\*\*

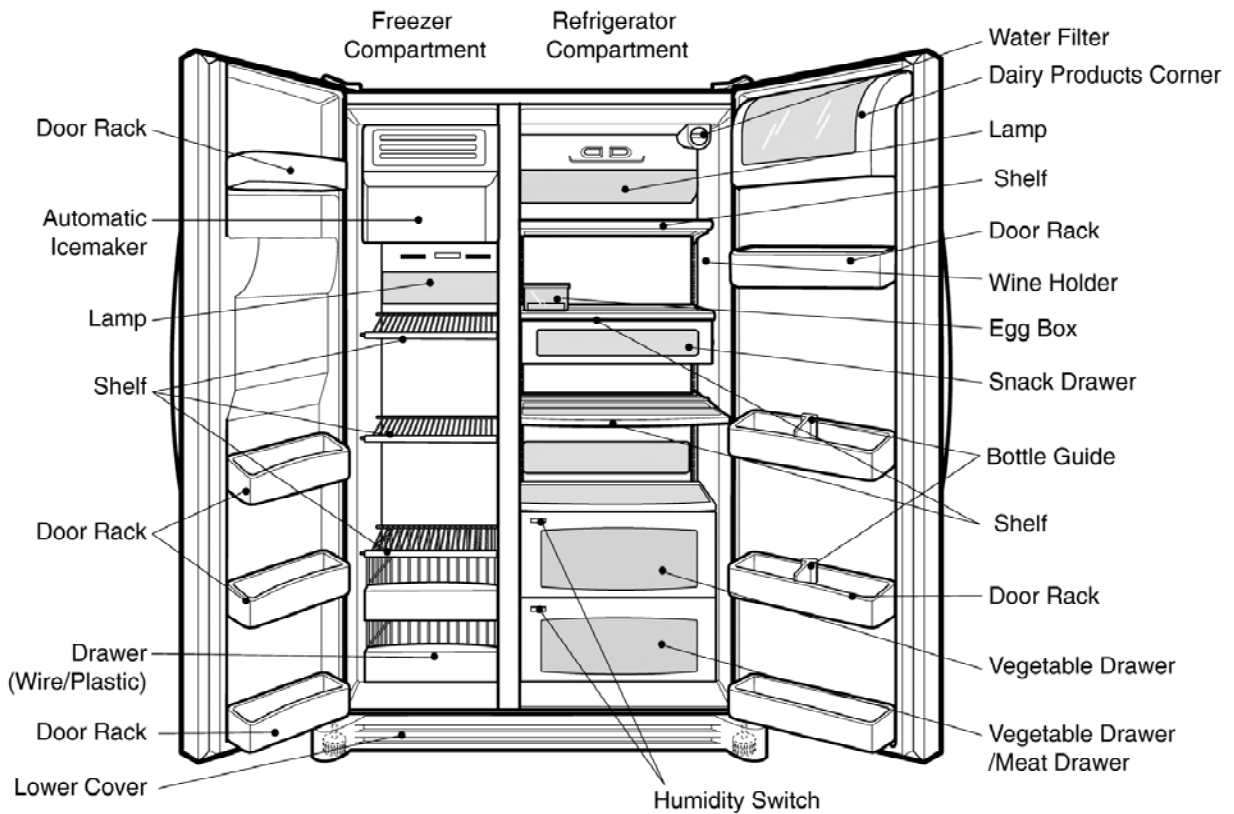
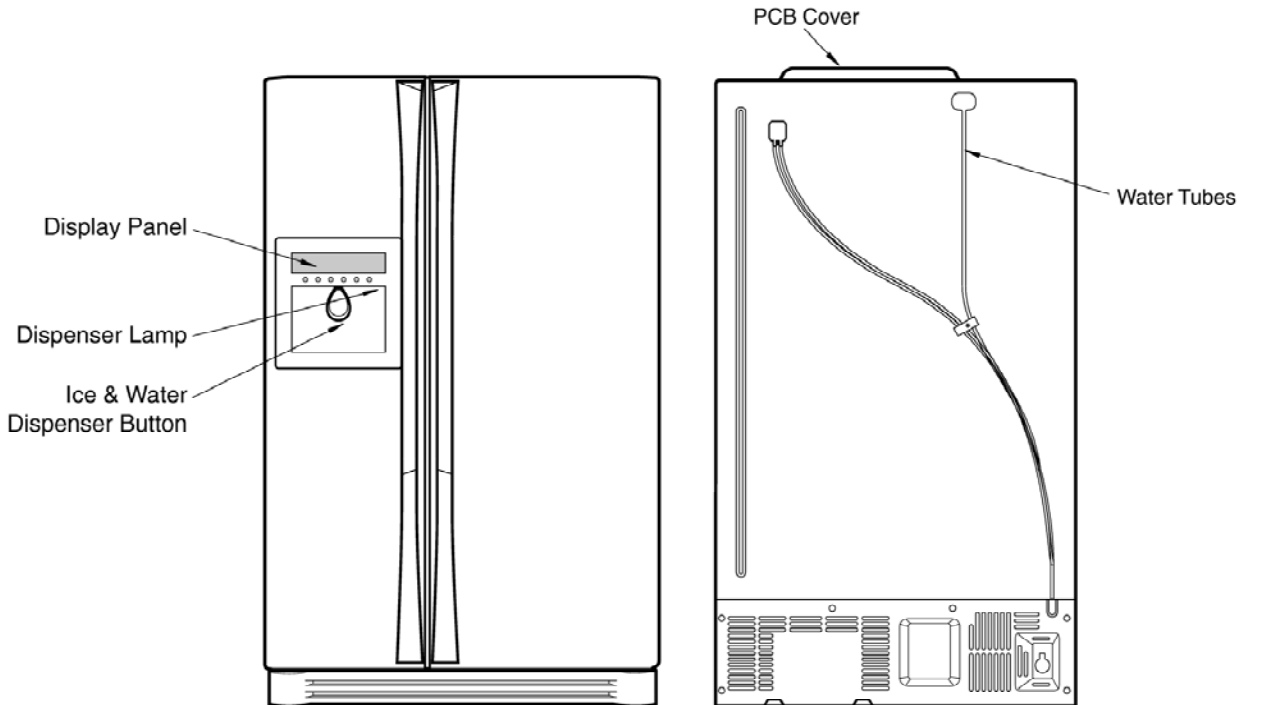

# PARTS IDENTIFICATION

Ref No. : LRSC26980TT

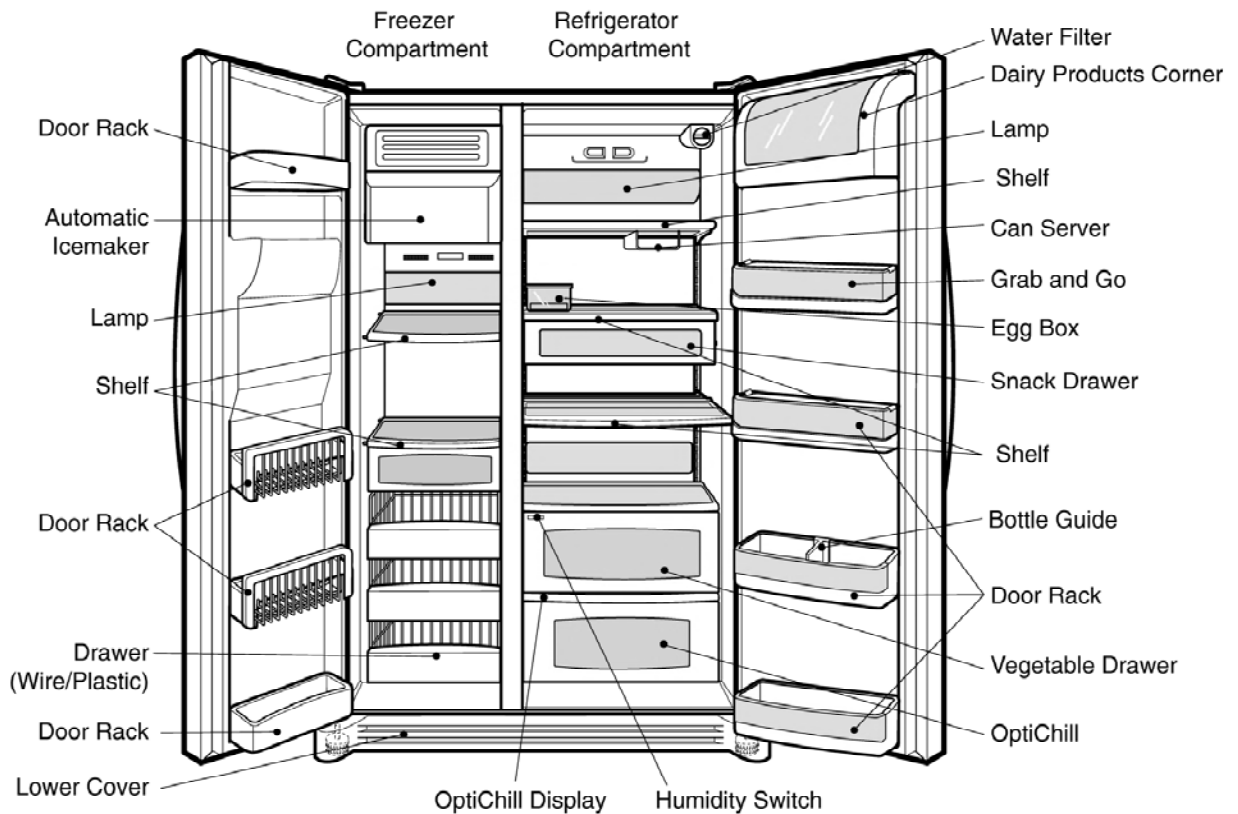
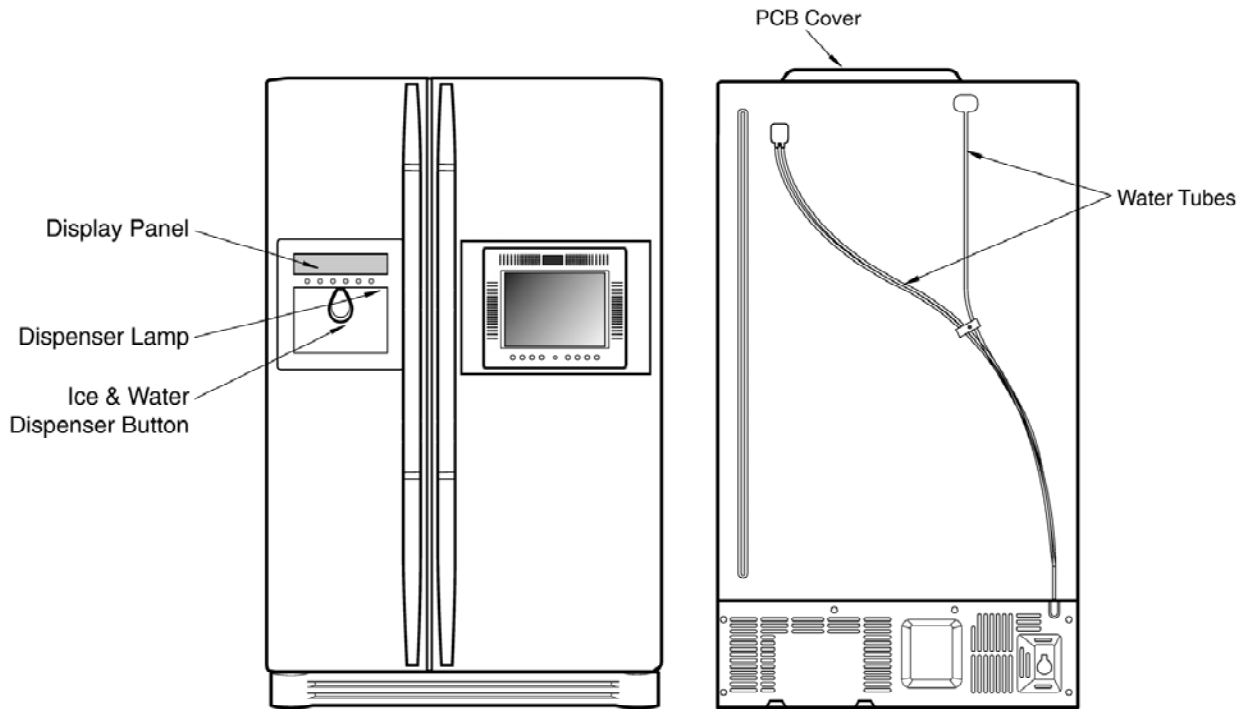

# HOW TO INSTALL REFRIGERATOR

## How to Adjust Door Height of Refrigerator

- Level the refrigerator first. (If the refrigerator is not installed on a flat floor, the height of freezer and refrigerator doors may not be the same.)

If the freezer door is lower than the refrigerator door:

If the freezer door is higher than the refrigerator door:

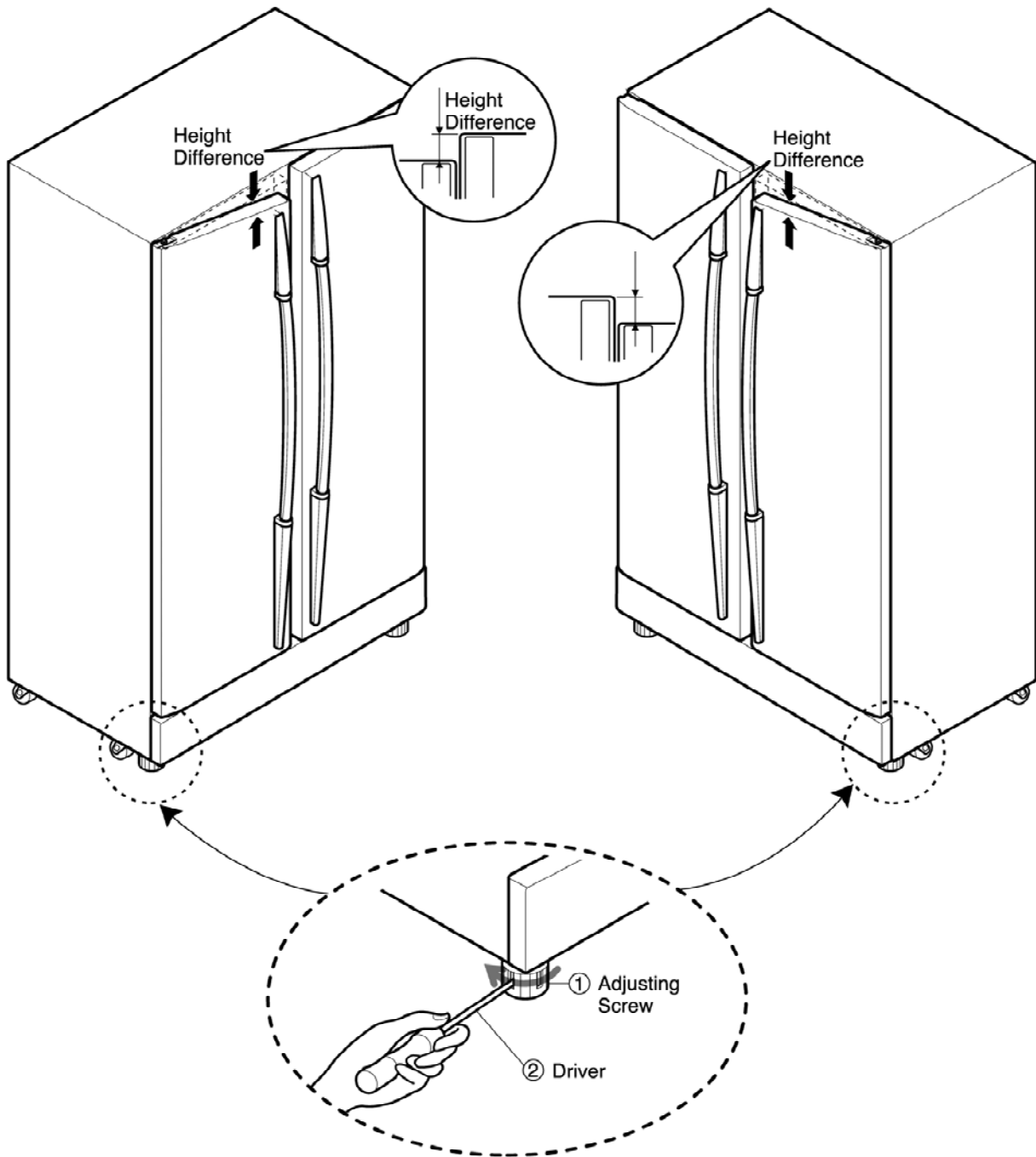

Insert a driver ② into the groove ① of the adjusting screw and turn in the direction of the arrow (clockwise) until the refrigerator is level.

Insert a driver ② into the groove ① of the adjusting screw and turn in the direction of the arrow (clockwise) until the refrigerator is level.

# HOW TO INSTALL REFRIGERATOR

## Filter

Replace the filter when the indicator light comes on or the performance of the icemaker or water dispenser decreases noticeably.

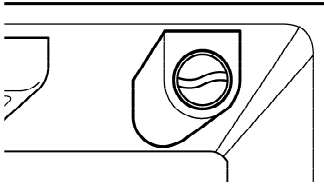

After changing the water filter cartridge, reset the water filter status display and indicator light by pressing and holding the **BUTTON** for 3 seconds.(page 18)

### 1. Remove the old cartridge.

Twist the knob of the cartridge counter clockwise.

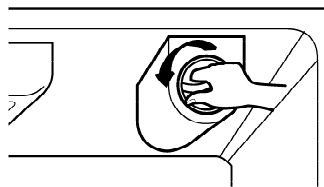

When the cartridge is removed, you will feel it click .

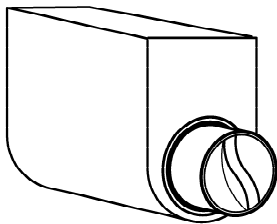

Pull out the cartridge.

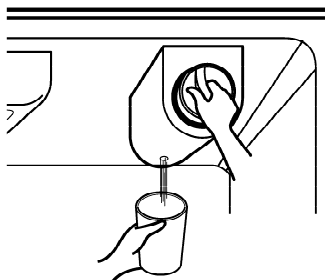

**NOTE:** There will be some water(25cc) in the filter cartridge. Some spilling may occur. Catch it in a bowl or towel.

### 2. Replace with a new cartridge.

Take the new cartridge out of its packaging and remove the protective cover from the o-rings.

With the cartridge knob in the vertical position, push the new filter cartridge into the cover until it stops.

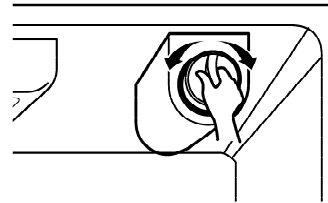

If you can't turn the filter from side to side, it isn't fully inserted. Push it in firmly and twist it into place. You will hear the snap when it clicks into place.

Using the handle, twist the cartridge clockwise about 1/4 turn.

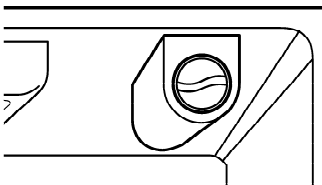
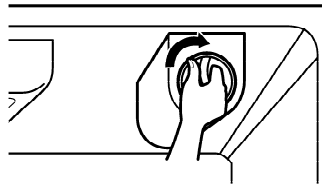

**3.** After replacing filter, dispense water through the water dispenser for 3 minutes to purge the system.

There may be a little air in the line, causing noise or hissing. Run the water at the dispenser until the hissing stops.

**NOTE:** - To purchase replacement water filter cartridges, visit your local appliance dealer or part distributor, or call 1-877-714-7486.

- You can also visit our website : [www.lgappliances.com](http://www.lgappliances.com)

# HOW TO INSTALL REFRIGERATOR

## Ice Maker



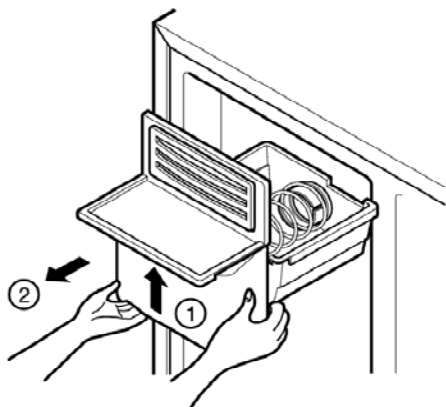

### 1) How to Control the Amount of Water Supplied to Icemaker.

**Caution :** • Do not put hands or tools into the chute to confirm the operation of geared motor.  
It may damage the refrigerator or hurt your hands.

To gain access to the ice maker, remove the ice bin in the upper part of the freezer compartment. Then use the water control switch to change the amount of water supplied to the ice maker.



Water supply amount TABLE

STAGE	TIME TO SUPPLY	INDICATIONS	REMARKS
1	4 sec.		The water amount will vary depending on the Water Control Switch setting as well as the water pressure of the connected water line.
2	4.5 sec.		
3	5 sec.		
4	5.5 sec.		
5	6 sec.		



# HOW TO INSTALL REFRIGERATOR

## ▲ WARNING

### Personal Injury Hazard

Avoid contact with the moving parts of the ejector mechanism or with the heating element that releases the cubes. DO NOT place fingers or hands on the automatic icemaking mechanism while the refrigerator is plugged in.

## 2) Operating instructions

A newly-installed refrigerator may take up to 24 hours to begin making ice.

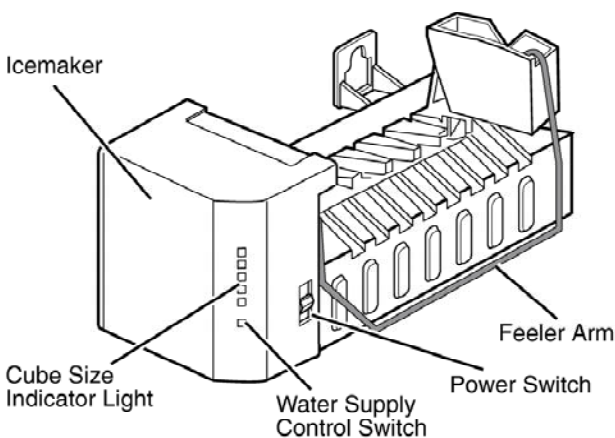

The icemaker will produce eight cubes per cycle—approximately 120–150 cubes in a 24-hour period, depending on freezer compartment temperature, room temperature, number of door openings and other operating conditions.

If the refrigerator is used before the water connection is made to the icemaker, set the power switch to **O (off)**.

When the refrigerator has been connected to the water supply, set the power switch to **I (on)**.

The icemaker will fill with water when it cools to freezing. A newly-installed refrigerator may take up to 24 hours to begin making ice cubes.

Throw away the first few batches of ice to allow the water line to clear.

Be sure nothing interferes with the sweep of the feeler arm.

When the bin fills to the level of the feeler arm, the icemaker will stop producing ice.

It is normal for several cubes to be stuck together.

If ice is not used frequently, old ice cubes will become cloudy, taste stale, and shrink.

**NOTE:** If the cube size is smaller or larger than you expected, you can regulate the size with the cube size button. (normally caused by variations in water pressure.)

Every time you press the cube size button, the indicator light goes up. The higher the position indicated, the larger the cubes will be. (1st step is the next after the 5th step.)

## 3) When you should set the icemaker power switch to **O (off)**

- When the water supply will be shut off for several hours.
- When the ice storage bin is removed for more than a minute or two.
- When the refrigerator will not be used for several days.

## 4) Normal sounds you may hear

- The icemaker water valve will buzz as the icemaker fills with water. If the power switch is in the **I (on)** position, it will buzz even if it has not yet been hooked up to water. To stop the buzzing, move the power switch to **O (off)**.

**NOTE:** Keeping the power switch in the **I (on)** position before the water line is connected can damage the icemaker.

- You will hear the sound of cubes dropping into the bin and water running in the pipes as the icemaker refills.

## 5) Preparing for Vacation

Set the icemaker power switch to **O (off)** and shut off the water supply to the refrigerator.

If the ambient temperature will drop below freezing, have a qualified servicer drain the water supply system (on some models) to prevent serious property damage due to flooding from ruptured water lines or connections.

# MICOM FUNCTION

## 1. Monitor Panel

### 1-1. LRSC26944\*\*, LRSC26980TT

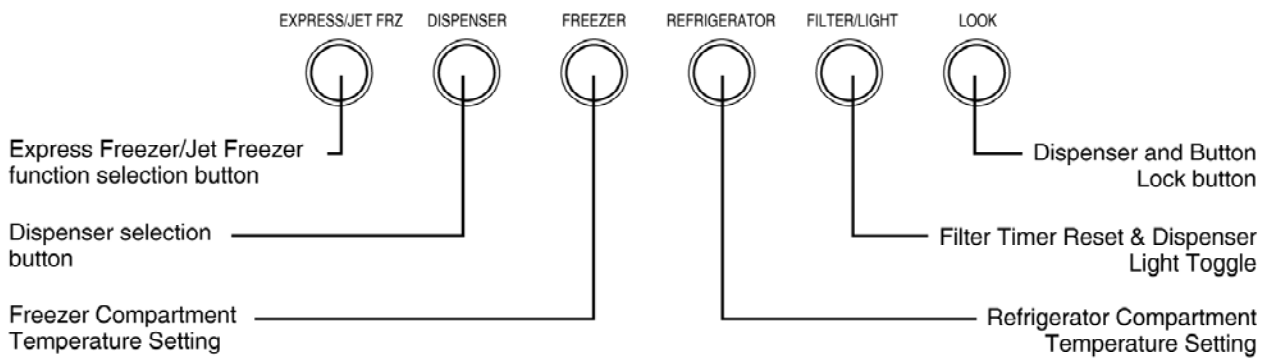
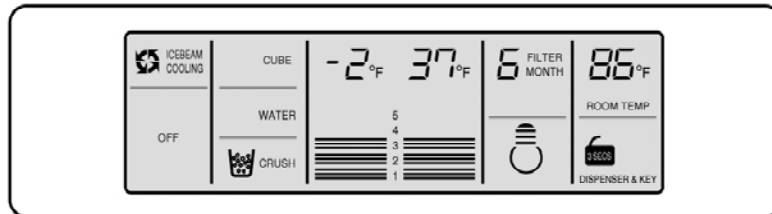

### 1-2. LRSC26930\*\*

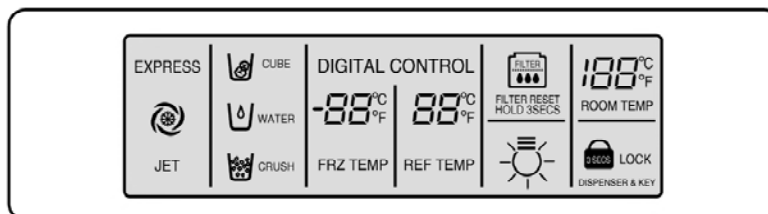



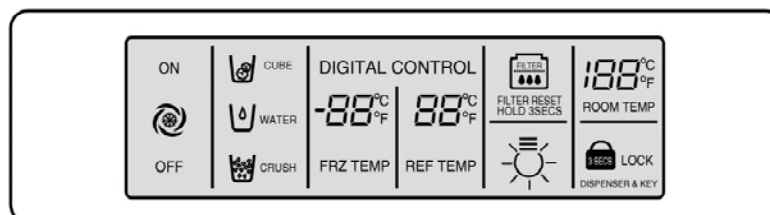

### 1-3. LRSC26910\*\*, LRSC26911\*\*, LRSC26920\*\*, LRSC26922\*\*

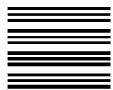

# MICOM FUNCTION

## 2. Refrigerator Functions

### 2-1-1. Temperature Selection (LRSC26944\*\*, LRSC26980TT)

Division	Power Initially On	1st Press	2st Press	3th Press	4th Press
Setting temperature	5 4 3 2 1 	5 4 3 2 1 	5 4 3 2 1 	5 4 3 2 1 	5 4 3 2 1 
Temperature Control	Medium	Medium Cold	Coldest	Warmest	Medium Warm
Freezer Control	-2 °F	-5 °F	-8 °F	7 °F	4 °F
Refrigeration Control	37 °F	34 °F	32 °F	46 °F	41 °F

\* The temperature can vary  $\pm 3$  °C depending on the load condition.

❖ Whenever pressing the button, setting is repeated in the order of (Medium) → (Medium Cold) → (Coldest) → (Warmest) → (Medium Warm).

- The actual inner temperature varies depending on the food status, as the indicated setting temperature is a target temperature, not the actual temperature within the refrigerator.
- A newly installed refrigerator will take 24 hours minimum for temperatures to stabilize. The temperature should be checked and adjusted as necessary after 2 or 3 days.

### 2-1-2. LCD Back Light Control (LRSC26944\*\*, LRSC26980TT)

1. In order to see the LCD display more easily, the backlight is turned on for one minute at the initial application of power, for 20 seconds when buttons are pressed, when a door is opened, and for 20 seconds after the door is closed.
2. When any display button is pressed while the backlight is off, the bell sounds and the backlight is turned on, but the button function is not performed. In other words, pressing any button turns on the backlight but does not cause any function to be initiated.
3. To check the LCD graphic and back light ON/OFF status, press and hold the EXPRESS/JET FRZ and FREEZER buttons. This will turn the back light on and illuminate all of the graphics. When the buttons are released, the graphic display returns to its previous setting and the back light is turned off.

### 2-1-3. Room temperature display function

1. The sensor for the **ROOM TEMP** display is located under the upper right hinge cover. Factors such as air flow, lighting, and other appliances operating within the room, may cause the display to differ from other temperature displays in the same room.
2. Ambient temperature is displayed between 16°F and 120°F. Temperatures 15°F and below are displayed as **Lo** and temperatures 121°F and above are displayed as **Hi**. If the ambient temperature sensor fails, **Er** will be displayed.

# MICOM FUNCTION

## 2-1-4. Lock function (dispenser and display button lock)

1. When the refrigerator is first powered up, the Lock function is turned off.
2. To lock the display, the dispenser, and the control panel, press and hold the LOCK button for more than 3 seconds. The LOCK text on the display will be turned on.
3. To unlock the controls, press and hold the lock button for more than 3 seconds. The LOCK text on the display will be turned off.

### LCD (LRSC26944\*\*, LRSC26980TT)

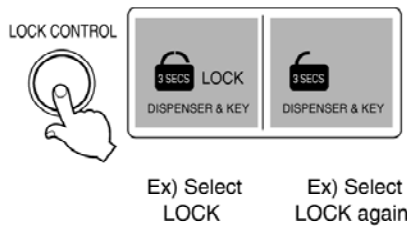

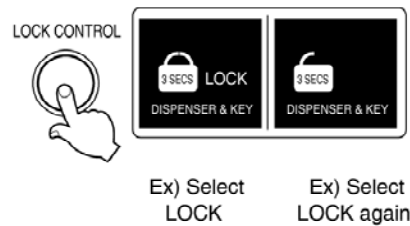

### LED (All models except LRSC26944\*\*, LRSC26980TT)



## 2-1-5. Filter condition display function

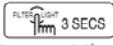

### LCD (LRSC26944\*\*, LRSC26980TT)

1. This units displays the months left before the water filter needs to be changed. It starts when the unit is first plugged in.
2. After 6 months have passed the filter change  will appear on the display. It will show FILTER LIGHT 3 SECS.
3. Press and hold the filter button for 3 seconds to reset the filter timer.

Classification	In initial Power On	Pass of a month	Pass of 2 months	Pass of 3 months	Pass of 4 months	Pass of 5 months	Pass of 6 months
Filter Status Display	6 FILTER MONTH	5 FILTER MONTH	4 FILTER MONTH	3 FILTER MONTH	2 FILTER MONTH	1 FILTER MONTH	0 FILTER MONTH 

### LED (All models except LRSC26944\*\*, LRSC26980TT)

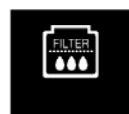
1. There is a replacement indicator light for the water filter cartridge on the dispenser.
2. The water filter should be replaced every six months or about 28,000 seconds' filtering time.
3. The water filter light and FILTER RESET HOLD 3 SECS will show in the display to remind you to change the filter soon.
4. After replacing the filter, press and hold the lock button for more than 3 seconds. The FILTER RESET HOLD 3 SECS will turn off.

Classification	In initial Power On / Filter RESET	Replace indicator light on
Filter Status Display		

# MICOM FUNCTION

## 2-2. Dispenser use selection

You can select water or ice.

- ❖ Select water, crushed ice, or ice cubes by cycling through the selections when pressing the **DISPENSER** button.
- ❖ Hold your cup in the dispenser for a few seconds after dispensing ice or water to allow the last pieces of ice or drops of water to fall into the cup.

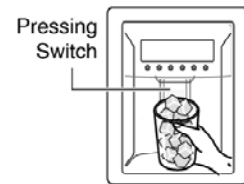
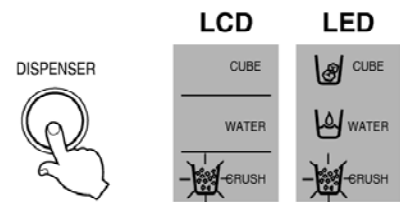

## 2-3. Express freezing/JET freezing selection

Please select this function for prompt freezing.

- The functions are cycled in the order shown below when the EXPRESS/JET FRZ button is pressed.
- The arrow mark graphic remains at the On status after flickering 4 times when selecting Special Refrigeration EXPRESS FRZ or JET FRZ.
- EXPRESS FREEZE and JET FREEZE operate for a set time and then default to normal freezer operation.

### LCD (LRSC26944\*\*, LRSC26980TT)



### LED (LRSC26930\*\*)



### LED (LRSC26910\*\*, LRSC26911\*\*, LRSC26920\*\*, LRSC26922\*\*)



## 2-4. Dispenser Light

- Dispenser switch or dispenser light button turns the dispenser light in the dispenser on and off.
- The dispenser light turns off automatically after 7 minutes.

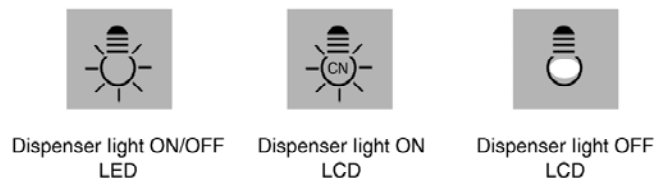

# MICOM FUNCTION

---

## 2-5. Express freezing

1. EXPRESS FREEZING improves the cooling speed of the freezer by running the compressor and the freezer fan.
2. In the event of power failure, EXPRESS FREEZING is cancelled and the freezer defaults to normal operation.
3. The temperature setting is not changed when EXPRESS FREEZING is selected.
4. The freezer compartment and refrigerator temperature settings can be changed even when EXPRESS FREEZING is selected and the cycle is underway.
5. The refrigerator compartment will operate at its usual setting even when EXPRESS FREEZING is selected or in progress.
6. If you select EXPRESS FREEZING, the refrigerator will default to its original setting at the end of the cycle.
7. If the defrost cycle is scheduled to come on while EXPRESS FREEZING is selected, EXPRESS FREEZING will operate only for the time that is not used by the defrost setting.
8. If you press EXPRESS FREEZING during the defrost cycle, the EXPRESS FREEZING indicator will turn on but the cycle will not run until the defrost cycle is completed.
9. If you press EXPRESS FREEZING within 7 minutes of the compressor's last run cycle, the EXPRESS FREEZING cycle will not begin until the 7 minute delay is complete.
10. The freezer fan runs at high speed when Express Freezing is selected.

## 2-6. Jet Freezing

1. Jet Freezing improves the cooling speed of the Jet Freezing Compartment by running the compressor and the Jet Freezing Compartment fan.
2. If there is a power failure, the Jet Freezing cycle is released and the freezer defaults to its original setting.
3. If Jet Freezing is selected, the compressor (after the compressor delay time has passed) and the freezer fan will be turned on. The temperature in the freezer will drop and the fan motor will be turned off for a set time, but the Jet Freezing fan will run for no more than two hours. After that, the Jet Freezing function is terminated and the freezer defaults to its original setting.
4. To keep the fan motor from freezing, it is switched on for 10 seconds once an hour.
5. The fan motor of jet freezing box will not be detected as a failure. (dc 12v operation)
6. When checking the Jet Freezing function, the Jet Freezing Compartment fan motor is switched on for 1 minute if the freezer adjustment button or the Express Freeze button is pressed for more than one second.

# MICOM FUNCTION

## 2-7. OptiChill Function

### ► LRSC26944\*\*, LRSC26980TT

#### 2-7-1. OptiChill Temperature Control

1. The Optichill is positioned at the bottom of the refrigerator compartment. It allows the user to select a more specific temperature based on the foods being stored, such as meat, fish, fruits and vegetables, etc.
2. The Optichill system consists of a sensor at the rear of the drawer, a damper, a fan motor between the Optichill compartment and the freezer, a heater at the bottom of the Optichill compartment, and a temperature adjustment display at the top.
3. The initial setting of the Optichill will be FRUIT VEGE.
4. Each time you press the SELECT button, the selection cycles through the settings in the order of FRUIT VEGE (39°F)→CHILLED ROOM (30°F)→PARTIAL FREEZING (27°F)→WINE(50°F)→FRUIT VEGE (39°F). The display will show the target temperature. If EXPRESS CHILL or THAW is selected, the selected temperature and NOTCH LED are not shown, and the temperature can be adjusted.
5. The Optichill sensor detects the temperature and relays this information to the MICOM. Based on the temperature and setting, The damper is opened or closed and the heater is on or off, as the conditions warrant.
6. If the Optichill damper hasn't moved within an hour, it is automatically opened or closed and then returned to its previous setting to keep it from freezing in one position.
7. In Display Check mode, the Optichill fan motor is turned on for one minute. To enter the Display Check mode, press and hold both the Freezer Adjust button and the Express Freezing button for three seconds.
8. If the Optichill fan motor hasn't run within an hour, it is automatically run for ten seconds once every hour to keep it from freezing in one position.



NOTCH	Partial Freezing	Chilled Room	Fruit VEGE	Wine
Display	27°F	30°F	39°F	50°F

THAW			Express Chill	Function
3.0lbs	1.5lbs	0.5lbs		
12Hr	8Hr	4Hr	90Min	50°F

# MICOM FUNCTION

---

## 2-7-2. OptiChill Thawing & Express Chill Control

1. When you press the SELECT button on the right, the THAW LED will light. The time for the selected function will be shown. You can cycle through the options in this order: EXPRESS CHILL/THAW OFF→EXPRESS CHILL (90 Min.)→THAW 0.5 lbs. (4 hours) ›THAW 1.5 lbs. (8 hours) ›THAW 3.5 lbs. (12 hours) ›EXPRESS CHILL/THAW OFF. If EXPRESS CHILL/THAW is selected, the NOTCH temperature in the Optichill will not be displayed.
2. If EXPRESS Chill is selected, the Optichill damper is opened and the fan motor is turned on. If the Optichill does not reach the set temperature after no more than ninety minutes, the setting is released.
3. The Optichill will count down from 90 minutes and show the remaining time in minutes.
4. When the EXPRESS CHILL cycle ends (or is released), the setting defaults to FRUIT VEGE (39°F).
5. If THAW is selected, the Optichill damper is closed and the time and temperature will be set according to the thawing function selected. The thawing function will be automatically terminated at the end of the set time.
6. When in THAW mode, the sensor controls the heater to keep the set temperature.
7. When in THAW mode, the display counts down the remaining time in minutes.
8. When the THAW mode is released, the Optichill automatically defaults to CHILLED ROOM (30°F).

## ► LRSC26930\*\*

### 2-7-3. OptiChill Temperature Control

1. The Optichill is in the bottom of the refrigerator compartment and allows the user to select and adjust the temperature based on the type food stored there. Selections include meat, fish, fruits and vegetables, etc. Storing foods at the proper temperature allows them to be stored for longer periods.
2. The Optichill consists of a temperature sensor, a damper between the Optichill and the freezer, and a temperature control/display at the top.
3. At initial power-up, the Optichill defaults to FRUIT VEGE. If the refrigerator door is opened, the Optichill LED will be on.
4. When you press the SELECT button on the left, the LED will light and indicate the setting. The time for the selected function will be shown. You can cycle through the options in this order: FRUIT VEGE (39°F)→CHILLED ROOM→PARTIAL FREEZING→FRUIT VEGE. The display will indicate the temperature for the selected setting.
5. The Optichill sensor detects the temperature and relays that information to the MICOM. When the set temperature is reached, the Optichill damper is closed. If the temperature rises, the damper is opened to allow the temperature to fall again.
6. If the Optichill damper hasn't moved within an hour, it is automatically moved and returned to its original setting once every hour to keep it from freezing in one position.



# MICOM FUNCTION

## 2-8. Variable freezing fan

1. To increase the cooling speed and load response speed, the MICOM will switch the freezer compartment fan motor between high and regular speeds.
2. The MICOM runs the freezer fan at high speed only at initial power-up, Express Freezing operation, or in response to a high load. The fan runs at the regular speed in all other circumstances.
3. When you open the refrigerator door while the fan is running at high speed, the MICOM will switch the fan to regular speed. If you open the freezer door or the home bar door, the fan is switched off.
4. If the MICOM determines the fan is obstructed (the blade cannot turn) it switches the fan off. When there is no fan rotation signal for 115 seconds, the MICOM displays an error on the display. To restart the fan, clear the obstruction and turn the power off and back on.

## 2-9. Cooling fan motor

1. The cooling fan is switched ON and OFF in conjunction with the compressor.
2. The cooling fan runs at a single speed.
3. The Failure sensing method is the same as in the fan motor of the freezing fan motor (refer to failure diagnosis function table for failure display).

## 2-10. Door alarm

1. If the doors are left open for more than one minute, the buzzer sounds three 1/2-second tones at thirty second intervals for four times.
2. If all the doors of freezing/cold storage room or home bar are closed during door open alarm, alarm is immediately turns off.

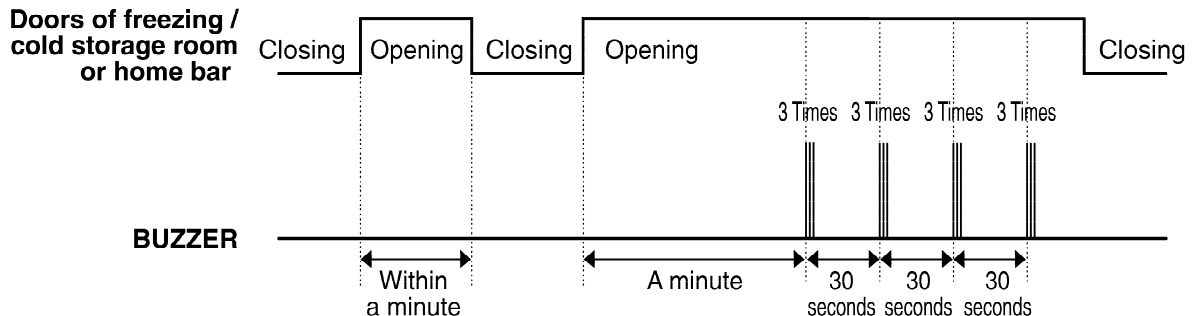

## 2-11. Button selection buzzer bell

1. The DING sounds if you press any button on the front display.

# MICOM FUNCTION

---

## **2-12. Automatic Defrost Signal**

1. The beep will sound if you press the test button on the main PCB.
2. The regular cycle sounds three short beeps one second apart.
3. When you select the automatic defrost cycle, the alarm sounds three series of three short beeps one minute apart.

## **2-13. Defrost Function**

1. Automatic defrost is performed whenever the compressor run time totals 7<sup>1</sup>/<sub>2</sub> hours.
2. At initial power-up, the defrost cycle will run when the total compressor runtime is 4<sup>1</sup>/<sub>2</sub> hours.
3. Defrost is completed when the defrost sensor temperature rises above 41°F (5°C) during the defrost cycle. The defrost cycle will terminate if the defrost sensor temperature does not achieve 41°F (5°C) within two hours.
4. The defrost cycle will not operate if the defrost sensor fails.

## **2-14. Refrigerator compartment lamp automatically off**

1. The refrigerator light is turned ON and OFF by the refrigerator door switch.
2. If the refrigerator light is on for more than 7 minutes, it will be turned off automatically. It will operate normally if you close the door and re-open it.

# MICOM FUNCTION

## 2-15. Sequential operation of components

Electromechanical parts of the appliance, such as the compressor, defrost heater, freezer fan, cooling fan, and damper motor, are operated sequentially as shown in the chart below to prevent noise and circuit overload from everything starting at once.

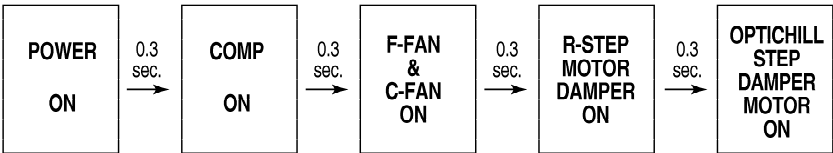
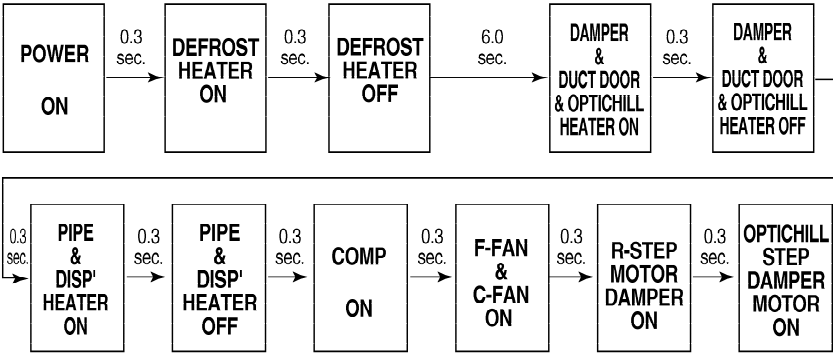
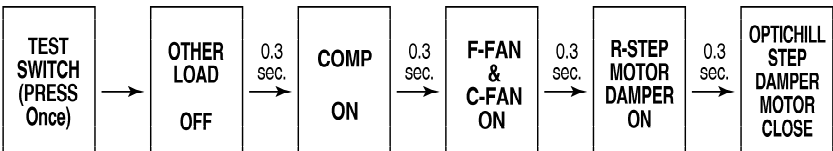
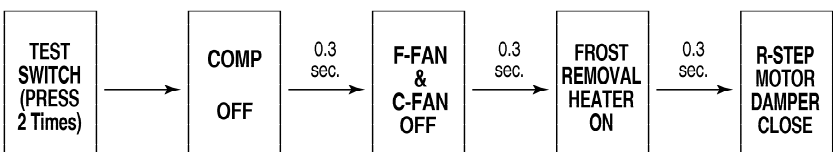
Function	Load Operation Sequence	Remark
In applying Initial power	<p>When temperature of a defrost sensor becomes more than 45°C (initial setup, movement)</p> 	If error occurs during operation, initial operation is not done.
	<p>When temperature of a defrost sensor becomes less than 45°C (power failure, service)</p> 	
TEST MODE	<p>Test mode 1 (Compulsory function)</p> 	The refrigerator will return to normal operation if you press the test switch once again while in Test Mode 2 or if the temperature of the defrost sensor surpasses 41°F (5°C). The compressor will run after the 7-minute delay.
	<p>Test mode 2 (Compulsory defrost)</p> 	

# MICOM FUNCTION

## 2-16. Failure Diagnosis

1. The failure diagnosis function indicates the area of a failure while the product is in operation.
2. When the appliance enters the failure mode, pressing buttons has no effect on the operation of the appliance.
3. If the error clears itself, the MICOM will reset and the appliance will operate as usual.
4. The failure code will be displayed as indicated in the drawings below. All other graphics and displays will be turned off.

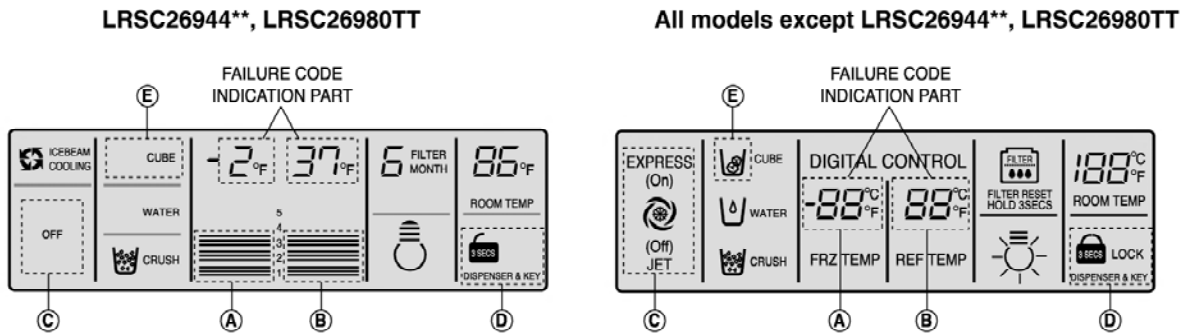

○ : Proper operation

No.	Item	Failure code indication part		Contents of failure	Product operation status in failure				
		Freezer notch temperature display	Refrigerator notch temperature display		Compressor	Freezing BLDC motor	Cooling BLDC motor	Defrost Heater	Stepping motor damper
1	Abnormal freezer sensor	Er	FS	Freezer sensor short circuit	ON for 15minutes/ OFF for 15minutes	Standard RPM	○	○	○
2	Abnormal refrigerator sensor 1 (R1) (Upper part in the refrigerator compartment)	Er	rS	Refrigerator sensor1 short circuit	○	Standard RPM	○	○	Full opening for 10 minutes/ Full closing for 15 minutes
3	Abnormal refrigerator sensor 2 (R2) (Middle part in the refrigerator compartment)	Normal display (Note 2)		Refrigerator sensor2 short circuit	○	Standard RPM	○	○	○
4	Abnormal defrost sensor	Er	dS	Abnormal short circuit	○	Standard RPM	○	No defrost	○
5	Failed defrosting	Er	dH	Defrost heater, temperature fuse short circuit, unplugged connector(indicated 4 hour later after trouble)	○	Standard RPM	○	○	○
6	Abnormal freezing BLDC motor	Er	FF	Motor defect, hooked of lead wire to fan, contact of structures with fan, short or open of lead wire(there is no signal of BLDC motor more than 115 seconds in operation of fan motor)	○	OFF	○	○	○
7	Abnormal cooling BLDC motor	Er	CF		○	Standard RPM	OFF	○	○
8	Communication Errors.	Er	CO	Short or open of lead wire connecting between main PCB and display PCB, transmission tr and receiving part	○	Standard RPM	○	○	○
9	Abnormal ambient sensor	Normal display (Note 1)		Ambient sensor short circuit	○	○	○	○	○
10	Abnormal Optichill sensor	Normal display (Note 2)		Optichill sensor short circuit	○	○	○	○	○

\* All displays turn off other than freezer room notch temperature display and refrigerator room notch temperature display(failure code indication part) when indicating failure modes(except for Note1, Note2).

# MICOM FUNCTION

---

Note1) The freezer and refrigerator temperature displays are also used to display error codes. The exception is that when the ambient temperature sensor fails, it shows Er in the ambient temperature display. All other display elements will function normally.

Note2) The R2 sensor, Optichill sensor, and water tank sensor are not indicated in the error codes, but you can see these errors by entering the test mode by pressing and holding the Freezer Temperature and Express/Jet Freezer buttons simultaneously.

R2-sensor (middle room)	<input type="checkbox"/>	Normal: LED or LCD graphic on the (C) part turns on Abnormal: LED or LCD graphic on the (C) part turns off	The other LED or LCD Graphics Turn On.
Optichill sensor	<input type="checkbox"/>	Normal: LED or LCD graphic on the (D) part turns on Abnormal: LED or LCD graphic on the (D) part turns off	
Water tank sensor	<input type="checkbox"/>	Normal: LEDs or LCDs graphic on the (E) part turns on Abnormal: LEDs or LCDs graphic on the (E) part turns off	

※ LCD (LED) check function: LCD (LED) Press and hold the Express Freeze button and the Freezer Temperature adjustment button to check the display. This will turn on the backlight and all display elements. Release the buttons and the display will return to its usual state.

# MICOM FUNCTION

## 2-17. Test Function

1. The test function is a self-diagnostic system designed to detect problems early and to make diagnosis and repair easier and quicker.
2. The test button is on the main PCB. Test mode can run for up to 2 hours and will then default to the normal operation mode if not reset manually.
3. The function buttons are inoperable when the refrigerator is in test mode.
4. When you have finished using the test mode, reset the appliance manually by unplugging it for several seconds.
5. If nonconforming contents such as sensor failure are found during performance of test mode, release the test mode and display the failure code.
6. The test button is inoperable if the display is showing failure codes. Reset the appliance manually to use the test button.

Mode	Operation	Contents	Remarks
Test 1	Press test button once (strong cold mode)	<ol style="list-style-type: none"> <li>1. Continuous operation of compressor</li> <li>2. Continuous operation of freezing BLDC motor (high-speed RPM) and cooling BLDC motor</li> <li>3. Defrost heater turns off</li> <li>4. Stepping motor damper is completely opened (baffle open)</li> <li>5. Optichill stepping motor damper is completely closed.</li> <li>6. All display LEDs or LCD graphics turn on.</li> </ol>	Freezer fan is off when door is open.
Test 2	Press test button once at the test mode 1 status (forced defrost mode)	<ol style="list-style-type: none"> <li>1. Compressor OFF</li> <li>2. Freezing BLDC motor and cooling BLDC motor turn off</li> <li>3. Defrost heater turns on</li> <li>4. Stepping motor damper is completely closed (baffle close)</li> <li>5. Optichill stepping motor damper is completely closed.</li> <li>6. All display LEDs or LCD graphics turn off. Except for (A), (B) LCD graphic. Except for (A): 22 (B): 22 LEDs.</li> </ol>	Return to the normal mode when the defrost sensor is above +5°C
Normal Status	Press test button once at the test mode 2 status	Return to the initial status.	Compressor will operate after delay for 7 minutes

### TEST MODE1 STATUS DISPLAY

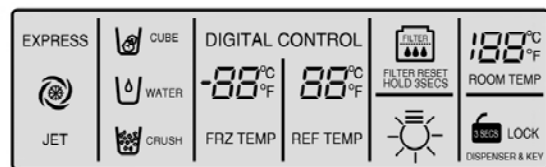

### TEST MODE2 STATUS DISPLAY

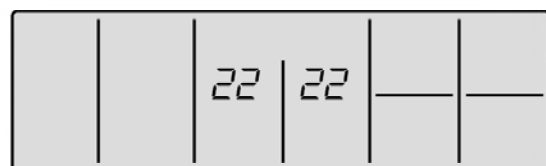
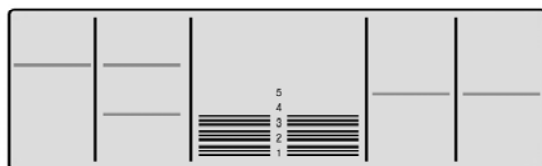

# MICOM FUNCTION

---

## 2-18. Door-mounted Dispenser

1. This feature allows dispensing of ice and water without having to open the refrigerator door.
2. Select CUBES, CRUSHED ICE, or WATER. Then press the dispenser switch. The duct door is operated by a solenoid. This door closes 5 seconds after ice is dispensed.
3. The dispenser does not work if the freezer door is open.
4. The dispenser will turn itself off after 3 minutes even if it does not receive an OFF signal. This prevents damage and overheating of the motor. The duct door will close 5 seconds after ice is dispensed.
5. The dispenser lamp is turned on and off by the dispenser switch.
6. Selection of Cubes/Crushed/Water
  - 1) Select Cubes/Crushed/Water using the selection button
  - 2) The default at power-up is Crushed
  - 3) The geared motor operates when Cubes or Crushed is selected.
7. Water Dispenser Function
  - 1) Select Water using the selection button
  - 2) The water line must be connected to the household water supply. The solenoid at the bottom right rear of the refrigerator operates to supply water.
  - 3) Press the dispenser switch to dispense water.

# EXPLANATION FOR MICOM CIRCUIT

## 1. Circuit Descriptions

### 1-1. Power circuit

#### LRSC269\*\*\*\*

The power circuit includes a Switched Mode Power Supply (SMPS). It consists of a rectifier (BD1 and CE1) converting AC to DC, a switch (IC2) switching the DC voltage, a transformer, and a feedback circuit (IC3 and IC4).

**Caution :** Since high voltage (160 Vdc) is maintained at the power terminal, wait at least 3 minutes after unplugging the appliance to allow the current to dissipate.

Voltage of every part is as follows:

Part	VA1	CE1	CE2	CE3	CE4	CE5
Voltage	120 Vac	160 Vdc	14 Vdc	12 Vdc	15.5 Vdc	5 Vdc

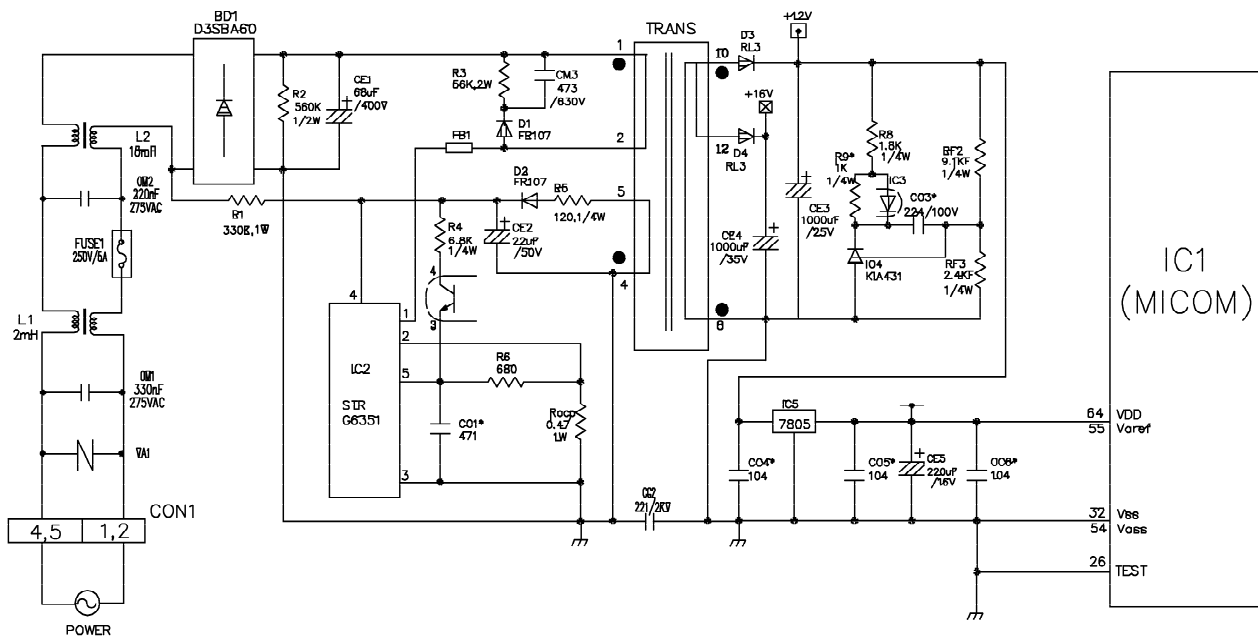



# EXPLANATION FOR MICOM CIRCUIT

## 1-2. Oscillation circuit

The oscillation circuit generates a basic clock signal for synchronization and time calculation related to the transmission of data and calculations made by the MICOM (IC1). The oscillator (OSC1) must always be replaced with an exact rated part, because if this spec is changes, the time calculations of the MICOM will be affected and it might not work at all.

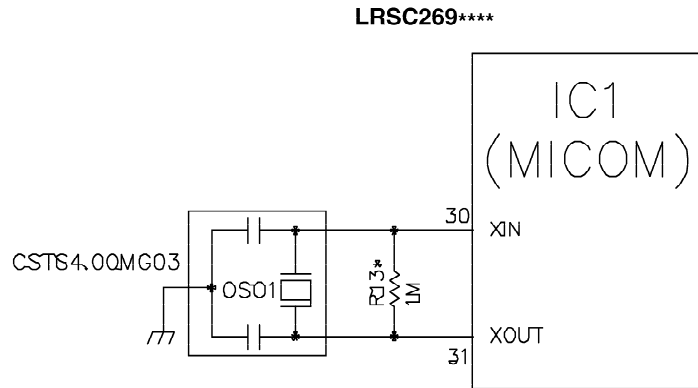

## 1-3. Reset circuit

The RESET circuit allows various parts of the MICOM, such as RAM, defrosting, etc., to be restarted from the initial state when power is interrupted or restored. A LOW signal applied to the reset terminal for 10 ms causes the MICOM to reset itself. During normal operation, the voltage at the reset terminal is 5 Vdc. If the reset fails, the MICOM will not operate.

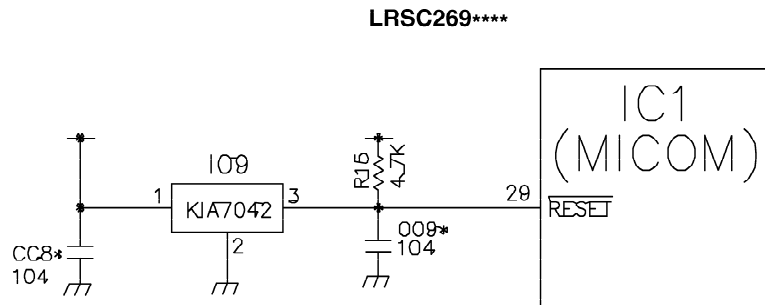

# EXPLANATION FOR MICOM CIRCUIT

## 1-4. Load driving circuit

- \* The fan operates at the regular speed even if the door of the refrigerator or freezer is opened. When the doors are closed, the fan reverts to its original speed.
- \* (A), (B), (C), and (D) of door switch for the freezer or refrigerator are connected to the door open sensing circuit in parallel toward both ends of the switch.
- \* In the TEST mode, the fan will stop if any door is opened. It will resume operation when the door is closed.

LRSC269\*\*\*\*

Type of Load	Compressor	Frost Removal Heater	AC Converting Relay	Refrigerator LAMP	Dispenser Heater	Magic room Heater
Measuring part (IC6)	IC6-14	IC6-10	IC7-16	IC6-13	IC6-11	IC6-12
Status	ON	Within 1 V				
	OFF	12 V				

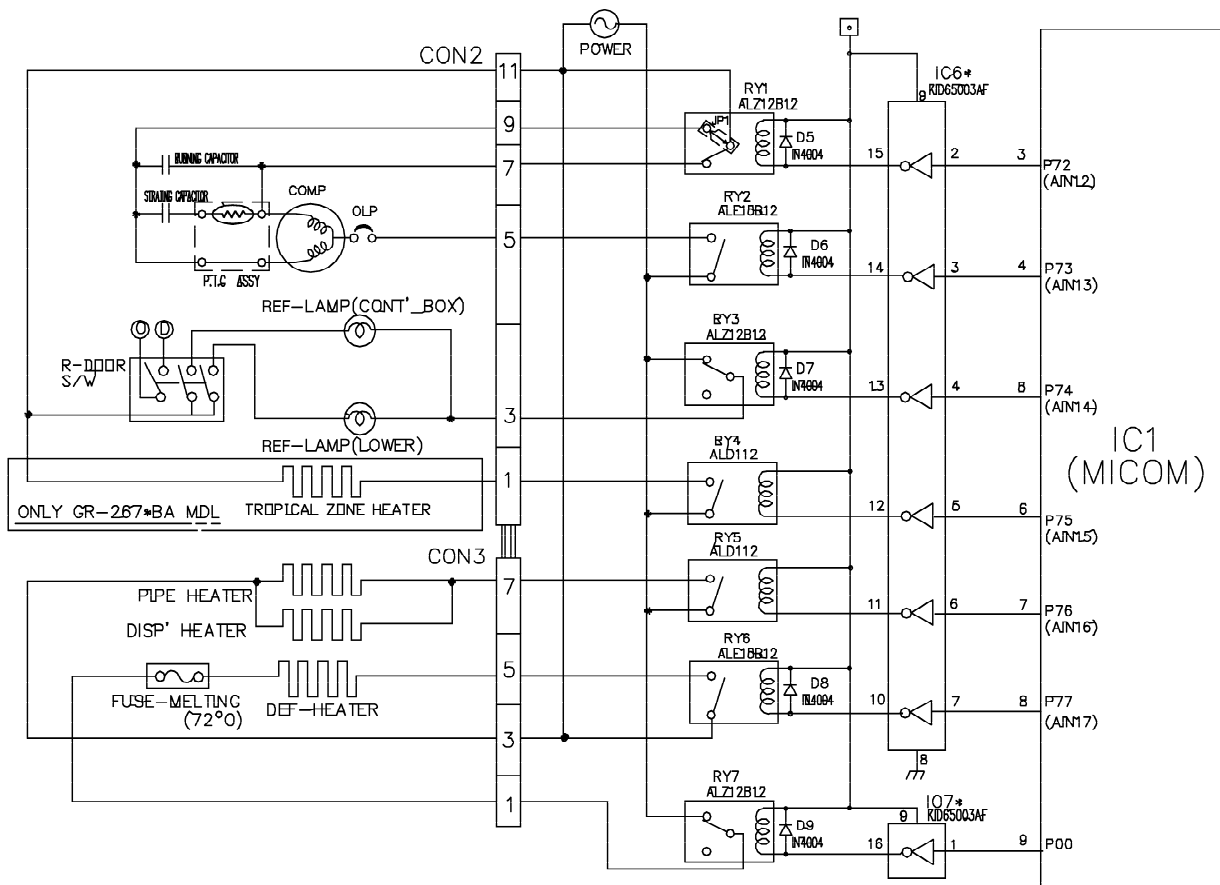

# EXPLANATION FOR MICOM CIRCUIT

## 1-5. Dispenser operation circuit

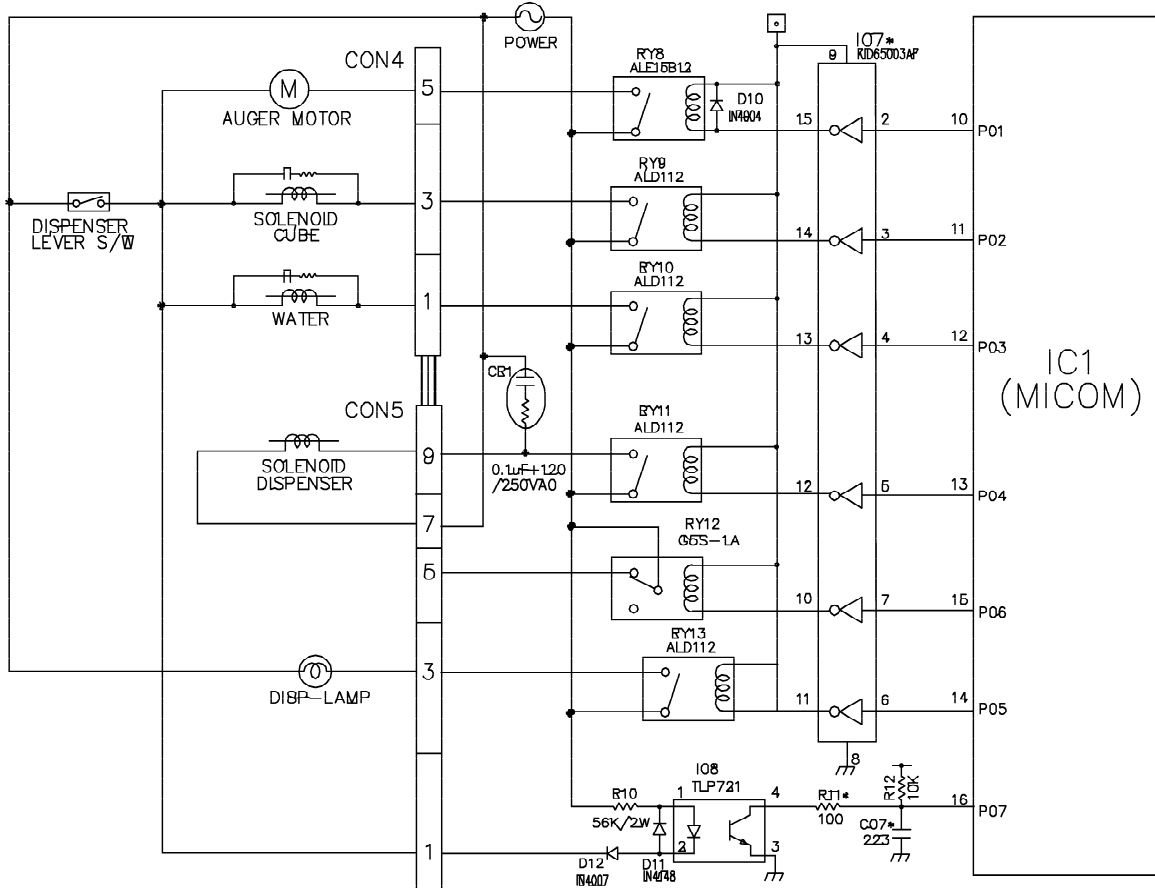

### Check load driving status

Type of Load	GEARED MOTOR	SOLENOID CUBE	WATER VALVE	SOLENOID DISPENSER
			WATER	
Measuring part	IC7-15	IC7-14	IC7-13	IC7-12
Status	ON	Within 1 V		
	OFF	12 V		

### Lever Switch sensing circuit

Measuring part	IC1(Micom) (No. 16)
Lever S/W	
On(Press)	
OFF	5V

# EXPLANATION FOR MICOM CIRCUIT

## 1-6. Door sensing circuit

LRSC269\*\*\*\*

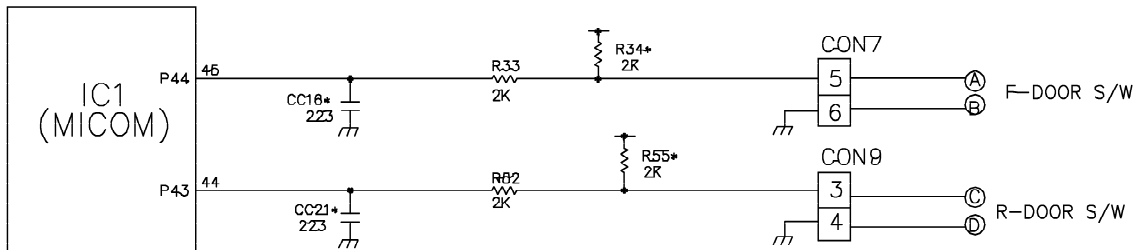

Measuring part	IC1 (MICOM) No. 47, 46 Pin
Door of Freezer / Refrigerator	
Closing	5 V (A - B, C - D) . Switch at both ends are at Off status)
Opening	5 V (A - B, C - D) . Switch at both ends are at On status)

\* Since door switches (A) and (B) are interconnected, if either fails, the other will not respond properly.

\* If either switch fails, the light will not come on.

# EXPLANATION FOR MICOM CIRCUIT

## 1-7. Temperature sensing circuit

LRSC269\*\*\*\*

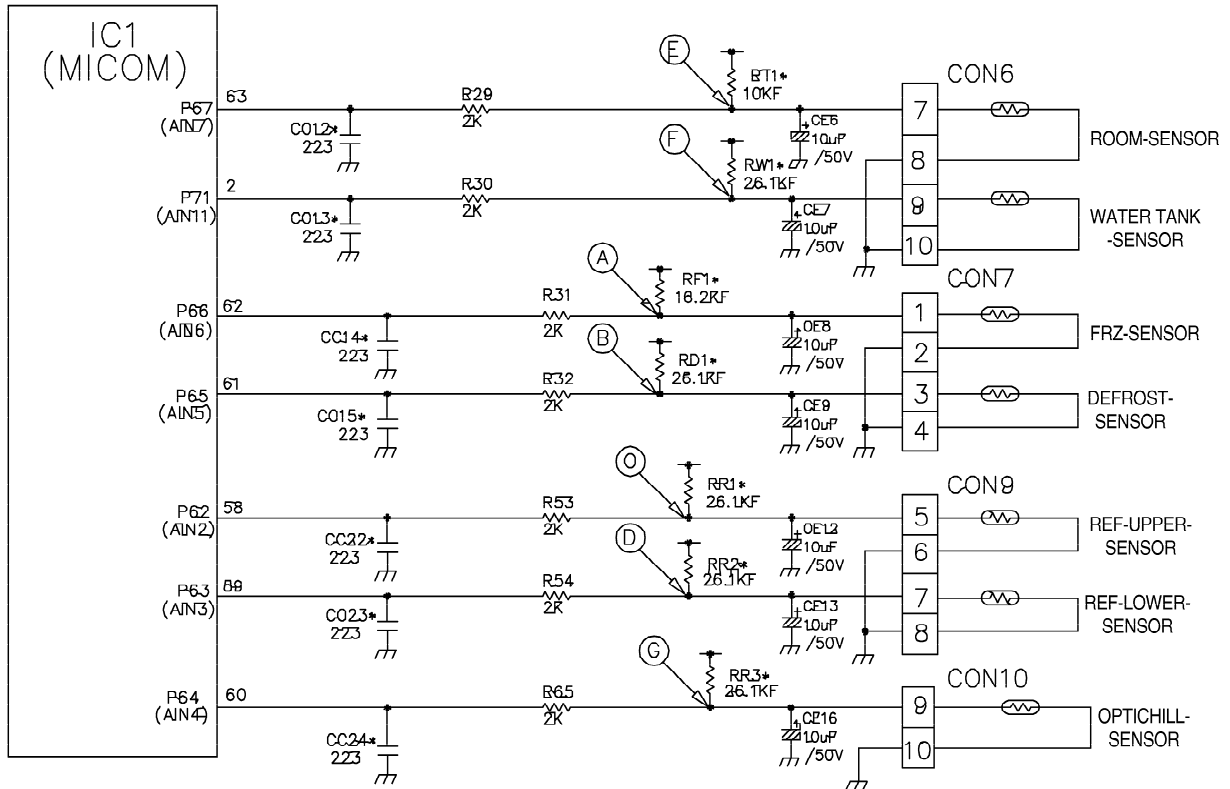

The circuits involving the freezer and refrigerator sensors control the temperature in both the freezer and the refrigerator. The Icemaker sensor detects when ice is made. The defrost sensor determines both the need for defrosting and the efficiency of the defrost operation. See the table below for voltages and checkpoints.

SENSOR	CHECK POINT	NORMAL(-30 °C ~ 50 °C)	IN SHORT	IN OPEN
Freezing sensor	POINT (A) Voltage	0.5 V~4.5 V	0 V	5 V
Defrost sensor	POINT (B) Voltage			
Refrigerator sensor 1	POINT (C) Voltage			
Refrigerator sensor 2	POINT (D) Voltage			
Room temperature sensor	POINT (E) Voltage			
Water tank sensor	POINT (F) Voltage			
Optichill sensor	POINT (G) Voltage			

# EXPLANATION FOR MICOM CIRCUIT

## 1-8. Switch entry circuit

The following circuits sense signal from the test switch, damper motor reed switch for testing and diagnosing the refrigerator.

LRSC269\*\*\*\*

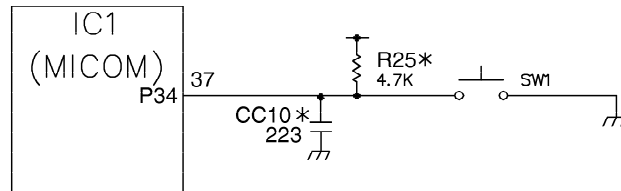

## 1-9. Option designation circuit (model separation function)

LRSC269\*\*\*\*

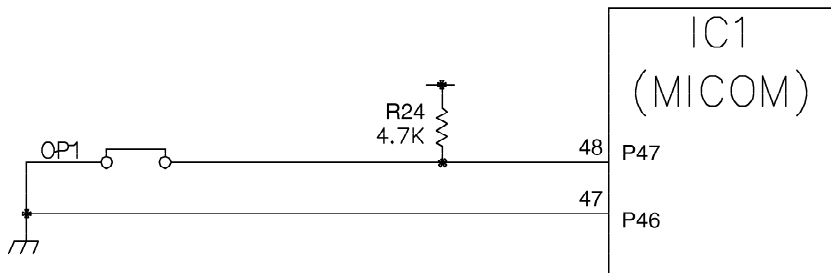

The circuits shown above vary according to which features are included on your particular model.

►These circuits are preset at the factory and cannot be altered.

Separation	Connection Status	Application Standard
OP1	Connection	OptiChill exist
	OUT	OptiChill doesn't exist

# EXPLANATION FOR MICOM CIRCUIT

## 1-10. Stepping motor circuit

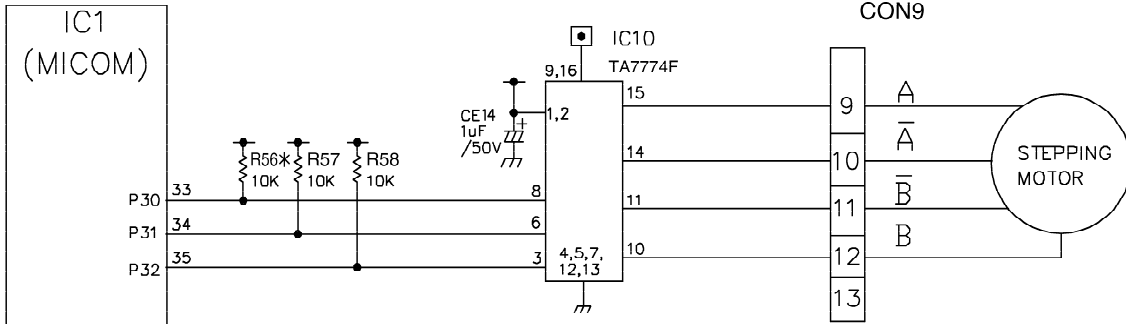

The motor is driven by magnetism formed in the areas of the coils and the stator. Rotation begins when a HIGH signal is applied to MICOM Pin 33 of IC10 (TA7774F). This causes an output of HIGH and LOW signals on MICOM pins 34 and 35.

**Explanation)** The stepping motor is driven by sending signals of 3.33 mSEC via MICOM pins 33, 34, and 35, as shown in the chart below. These signals are output via terminals 10, 11, 14, and 15 via input terminals 3, 6, and 8 of IC10 (TA7774F), the motor drive chip. The output signals allow the coils wound on each phase of the stator to form a magnetic field, which causes rotation. Input to the terminals INA and INB of IC10 as shown in the chart below drives the motor.

CCW (Reverse rotation) ← ————— → (Positive rotation) CW

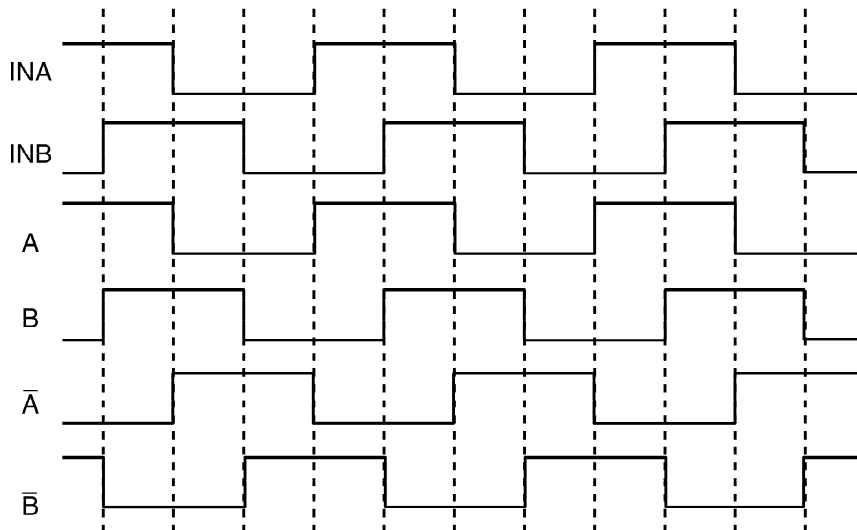

# EXPLANATION FOR MICOM CIRCUIT

## 1-11. Fan motor driving circuit (freezer, mechanical area)

1. The circuit cuts all power to the fan drive IC, resulting in a standby mode.
2. This circuit changes the speed of the fan motor by varying the DC voltage between 7.5 Vdc and 16 Vdc.
3. This circuit stops the fan motor by cutting off power to the fan when it senses a lock-up condition.

LRSC269\*\*\*\*

	Ⓐ, Ⓓ part	Ⓑ part	Ⓔ part	Ⓒ, Ⓕ part
Motor OFF	5V	2V or less	2V or less	0 V
Motor ON	2 ~ 3V	12 ~ 14V	8 ~ 16V	0 V

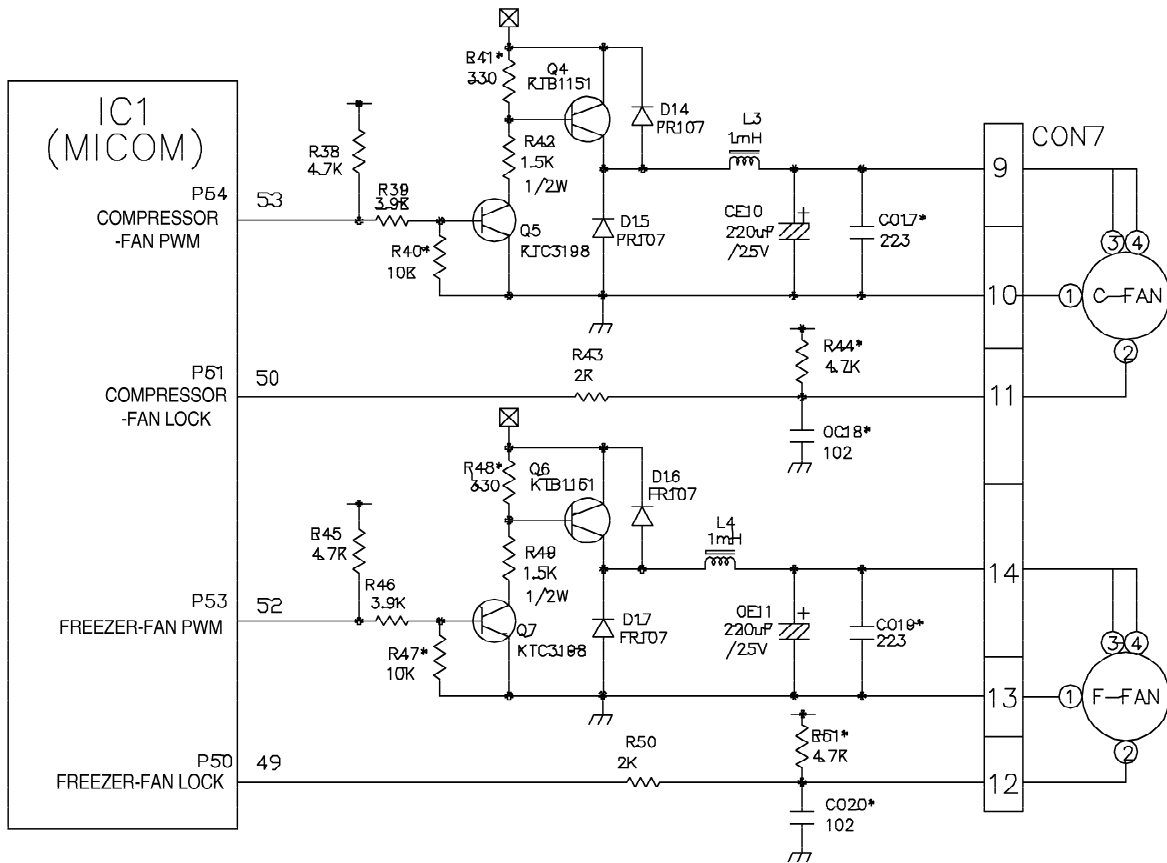



# EXPLANATION FOR MICOM CIRCUIT

## 1-12. Temperature compensation circuit

LRSC269\*\*\*\*

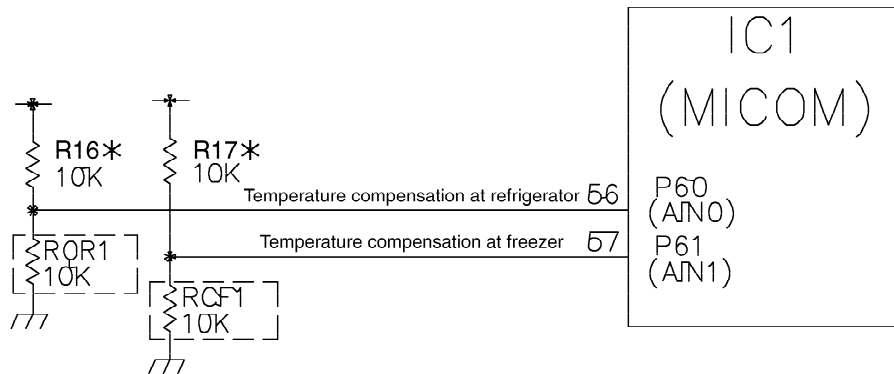

Freezer		Refrigerator		Remarks
Resistance value (RCF1)	Temperature compensation	Resistance value (RCR1)	Temperature compensation	
180 kΩ	+5 °C [+9°F]	180 kΩ	+2.5 °C [+4.5°F]	Warmer ↑
56 kΩ	+4 °C [+7.2°F]	56 kΩ	+2.0 °C [+3.6°F]	
33 kΩ	+3 °C [+5.4°F]	33 kΩ	+1.5 °C [+2.7°F]	
18 kΩ	+2 °C [+3.6°F]	18 kΩ	+1.0 °C [+1.8°F]	
12 kΩ	+1 °C [+1.8°F]	12 kΩ	+0.5 °C [+0.9°F]	
10 kΩ	0 °C [0°F]	10 kΩ	0 °C [0°F]	Reference temperature
8.2 kΩ	-1 °C [-1.8°F]	8.2 kΩ	-0.5 °C [-0.9°F]	Cooler ↓
5.6 kΩ	-2 °C [-3.6°F]	5.6 kΩ	-1.0 °C [-1.8°F]	
3.3 kΩ	-3 °C [-5.4°F]	3.3 kΩ	-1.5 °C [-2.7°F]	
2 kΩ	-4 °C [-7.2°F]	2 kΩ	-2.0 °C [-3.6°F]	
470 Ω	-5 °C [-9°F]	470 Ω	-2.5 °C [-4.5°F]	

► Temperature compensation table by adjustment value (difference value against current temperature)

Ex) If you change compensation resistance of (RCR1) from 10 kΩ (current resistance) to 18 kΩ (modified resistance), the temperature will increase by +1°C[+1.8°F].

# EXPLANATION FOR MICOM CIRCUIT

► Temperature compensation table for the refrigerator is as follows:

	Modification resistance Current resistance	470 Ω	2 kΩ	3.3 kΩ	5.6 kΩ	8.2 kΩ	10 kΩ	12 kΩ	18 kΩ	33 kΩ	56 kΩ	180 kΩ
		Refrigerator (RCR1)	470Ω	No change	0.5 °C [0.9 °F] Up	1 °C [1.8 °F] Up	1.5 °C [2.7 °F] Up	2 °C [3.6 °F] Up	2.5 °C [4.5 °F] Up	3 °C [5.4 °F] Up	3.5 °C [6.3 °F] Up	4 °C [7.2 °F] Up
2 kΩ	0.5 °C [0.9 °F] Down		No change	0.5 °C [0.9 °F] Up	1 °C [1.8 °F] Up	1.5 °C [2.7 °F] Up	2 °C [3.6 °F] Up	2.5 °C [4.5 °F] Up	3 °C [5.4 °F] Up	3.5 °C [6.3 °F] Up	4 °C [7.2 °F] Up	4.5 °C [8.1 °F] Up
3.3 kΩ	1 °C [1.8 °F] Down		0.5 °C [0.9 °F] Down	No change	0.5 °C [0.9 °F] Up	1 °C [1.8 °F] Up	1.5 °C [2.7 °F] Up	2 °C [3.6 °F] Up	2.5 °C [4.5 °F] Up	3 °C [5.4 °F] Up	3.5 °C [6.3 °F] Up	4 °C [7.2 °F] Up
5.6 kΩ	1.5 °C [2.7 °F] Down		1 °C [1.8 °F] Down	0.5 °C [0.9 °F] Down	No change	0.5 °C [0.9 °F] Up	1 °C [1.8 °F] Up	1.5 °C [2.7 °F] Up	2 °C [3.6 °F] Up	2.5 °C [4.5 °F] Up	3 °C [5.4 °F] Up	3.5 °C [6.3 °F] Up
8.2 kΩ	2 °C [3.6 °F] Down		1.5 °C [2.7 °F] Down	1 °C [1.8 °F] Down	0.5 °C [0.9 °F] Drop	No change	0.5 °C [0.9 °F] Up	1 °C [1.8 °F] Up	1.5 °C [2.7 °F] Up	2 °C [3.6 °F] Up	2.5 °C [4.5 °F] Up	3 °C [5.4 °F] Up
10 kΩ	2.5 °C [4.5 °F] Down		2 °C [3.6 °F] Down	1.5 °C [2.7 °F] Down	1 °C [1.8 °F] Down	0.5 °C [0.9 °F] Down	No change	0.5 °C [0.9 °F] Up	1 °C [1.8 °F] Up	1.5 °C [2.7 °F] Up	2 °C [3.6 °F] Up	2.5 °C [4.5 °F] Up
12 kΩ	3 °C [5.4 °F] Down		2.5 °C [4.5 °F] Down	2 °C [3.6 °F] Down	1.5 °C [2.7 °F] Down	1 °C [1.8 °F] Down	0.5 °C [0.9 °F] Down	No change	0.5 °C [0.9 °F] Up	1 °C [1.8 °F] Up	1.5 °C [2.7 °F] Up	2 °C [3.6 °F] Up
18 kΩ	3.5 °C [6.3 °F] Down		3 °C [5.4 °F] Down	2.5 °C [4.5 °F] Down	2 °C [3.6 °F] Down	1.5 °C [2.7 °F] Down	1 °C [1.8 °F] Down	0.5 °C [0.9 °F] Down	No change	0.5 °C [0.9 °F] Up	1 °C [1.8 °F] Up	1.5 °C [2.7 °F] Up
33 kΩ	4 °C [7.2 °F] Down		3.5 °C [6.3 °F] Down	3 °C [5.4 °F] Down	2.5 °C [4.5 °F] Down	2 °C [3.6 °F] Down	1.5 °C [2.7 °F] Down	1 °C [1.8 °F] Down	0.5 °C [0.9 °F] Down	No change	0.5 °C [0.9 °F] Up	1 °C [1.8 °F] Up
56 kΩ	4.5 °C [8.1 °F] Down		4 °C [7.2 °F] Down	3.5 °C [6.3 °F] Down	3 °C [5.4 °F] Down	2.5 °C [4.5 °F] Down	2 °C [3.6 °F] Down	1.5 °C [2.7 °F] Down	1 °C [1.8 °F] Down	0.5 °C [0.9 °F] Down	No change	0.5 °C [0.9 °F] Up
180 kΩ	5 °C [9 °F] Down		4.5 °C [8.1 °F] Down	4 °C [7.2 °F] Down	3.5 °C [6.3 °F] Down	3 °C [5.4 °F] Down	2.5 °C [4.5 °F] Down	2 °C [3.6 °F] Down	1.5 °C [2.7 °F] Down	1 °C [1.8 °F] Down	0.5 °C [0.9 °F] Down	No change

► Temperature compensation for the freezer is performed the same as for the refrigerator. The value for the freezer is twice that of the refrigerator.

► This circuit enters the necessary level of temperature compensation for adjusting the appliance. The method is the same for every model in this appliance family.

# EXPLANATION FOR MICOM CIRCUIT

## Compensation circuit for temperature of freezer

LRSC269\*\*\*\*

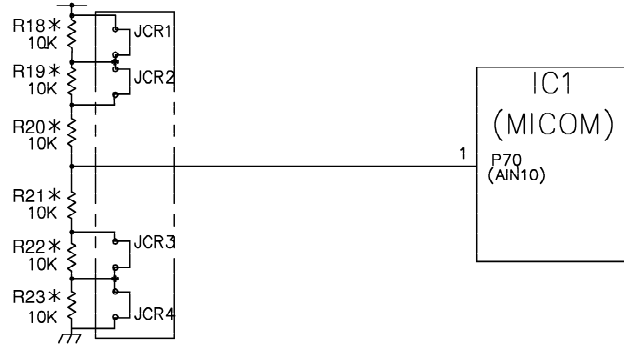

Temperature compensation in CUT		
JCR1	+1 °C [+1.8 °F]	+2 °C [+3.6 °F]
JCR2	+1 °C [+1.8 °F]	
JCR3	-1 °C [-1.8 °F]	-2 °C [-3.6 °F]
JCR4	-1 °C [-1.8 °F]	

Compensation for weak-cold		Compensation for over-cold		Temperature compensation value of refrigerator	Remarks
JCR3	JCR4	JCR1	JCR2		
<input type="checkbox"/>	<input type="checkbox"/>	<input type="checkbox"/>	<input type="checkbox"/>	0 °C (In shipment from factory)	
CUT	<input type="checkbox"/>	<input type="checkbox"/>	<input type="checkbox"/>	-1 °C [-1.8 °F]	
<input type="checkbox"/>	CUT	<input type="checkbox"/>	<input type="checkbox"/>	-1 °C [-1.8 °F]	
<input type="checkbox"/>	<input type="checkbox"/>	CUT	<input type="checkbox"/>	+1 °C [+1.8 °F]	
<input type="checkbox"/>	<input type="checkbox"/>	<input type="checkbox"/>	CUT	+1 °C [+1.8 °F]	
CUT	CUT	<input type="checkbox"/>	<input type="checkbox"/>	-2 °C [-3.6 °F]	
<input type="checkbox"/>	<input type="checkbox"/>	CUT	CUT	+2 °C [+3.6 °F]	
CUT	<input type="checkbox"/>	CUT	<input type="checkbox"/>	0 °C [0 °F]	
CUT	<input type="checkbox"/>	<input type="checkbox"/>	CUT	0 °C [0 °F]	
<input type="checkbox"/>	CUT	CUT	<input type="checkbox"/>	0 °C [0 °F]	
<input type="checkbox"/>	CUT	<input type="checkbox"/>	CUT	0 °C [0 °F]	
CUT	CUT	CUT	<input type="checkbox"/>	-1 °C [-1.8 °F]	
<input type="checkbox"/>	CUT	CUT	CUT	+1 °C [+1.8 °F]	
CUT	CUT	CUT	CUT	0 °C [0 °F]	

► This circuit allows adjustment of the set temperature for compensation by changing jumpers at locations JCR1~JCR4.

# EXPLANATION FOR MICOM CIRCUIT

## 1-13. Communication circuit

The following communication circuit is used for exchanging information between the main MICOM of the Main PCB and the dedicated MICOM of the LED (LCD) Display PCB.

A bi-directional lead wire assembly between the two boards is required for the display to function properly.

Poor communication occurs if a continuous information exchange fails to last more than 2 minutes between main MICOM of main PCB and LCD (LED) dedicated MICOM for LCD (LED) control of display PCB.

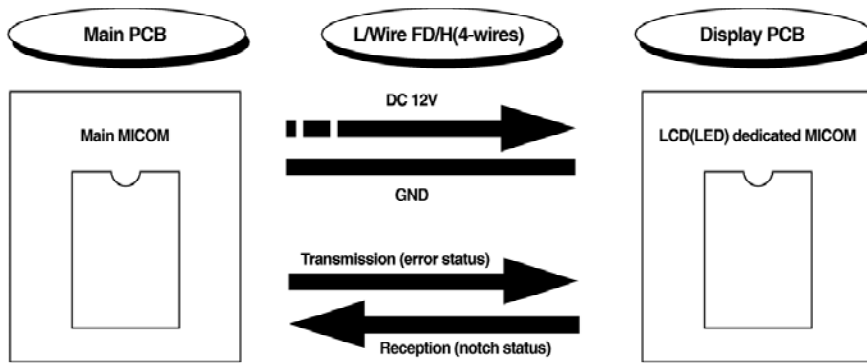

LRSC269\*\*\*\*

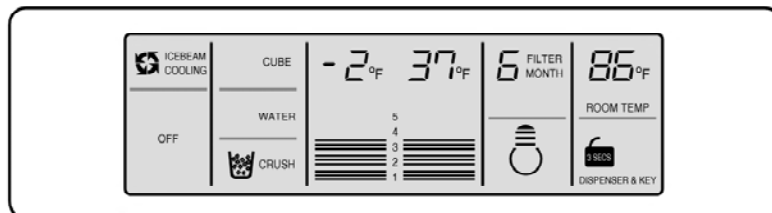
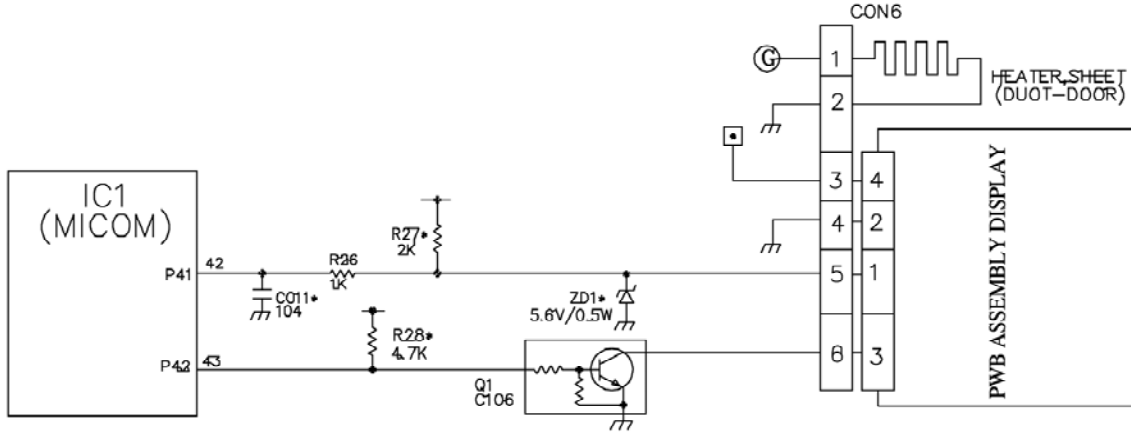

# EXPLANATION FOR MICOM CIRCUIT

Sensor resistance characteristics table

Measuring Temperature (°C)	Freezing Sensor	Cold storage sensor 1&2 Frost removal sensor, Outside sensor
-20 °C (-4 °F)	22.3 kΩ	77 kΩ
-15 °C (5 °F)	16.9 kΩ	60 kΩ
-10 °C (14 °F)	13.0 kΩ	47.3 kΩ
-5 °C (23 °F)	10.1 kΩ	38.4 kΩ
0 °C (32 °F)	7.8 kΩ	30 kΩ
+5 °C (41 °F)	6.2 kΩ	24.1 kΩ
+10 °C (50 °F)	4.9 kΩ	19.5 kΩ
+15 °C (59 °F)	3.9 kΩ	15.9 kΩ
+20 °C (68 °F)	3.1 kΩ	13 kΩ
+25 °C (77 °F)	2.5 kΩ	11 kΩ
+30 °C (86 °F)	2.0 kΩ	8.9 kΩ
+40 °C (104 °F)	1.4 kΩ	6.2 kΩ
+50 °C (122 °F)	0.8 kΩ	4.3 kΩ

- ▶ Resistance value allowance of sensor is  $\pm 5\%$ .
- ▶ When measuring the resistance value of the sensor, allow the temperature of that sensor to stabilize for at least 3 minutes before measuring. This delay is necessary because of the sense speed relationship.
- ▶ Use a digital tester to measure the resistance. An analog tester has too great a margin of error.
- ▶ Resistance of the cold storage sensor 1 and 2 should be measured with a digital tester after separating CON8 of the PWB ASSEMBLY and the MAIN part.
- ▶ Resistance of the freezing sensor shall be measured with a digital tester after separating CON7 of the PWB ASSEMBLY and the MAIN part.

# EXPLANATION FOR MICOM CIRCUIT

## 1-14. OptiChill stepping MOTOR/Display

LRSC26944\*\*, LRSC26930\*\*, LRSC26980TT

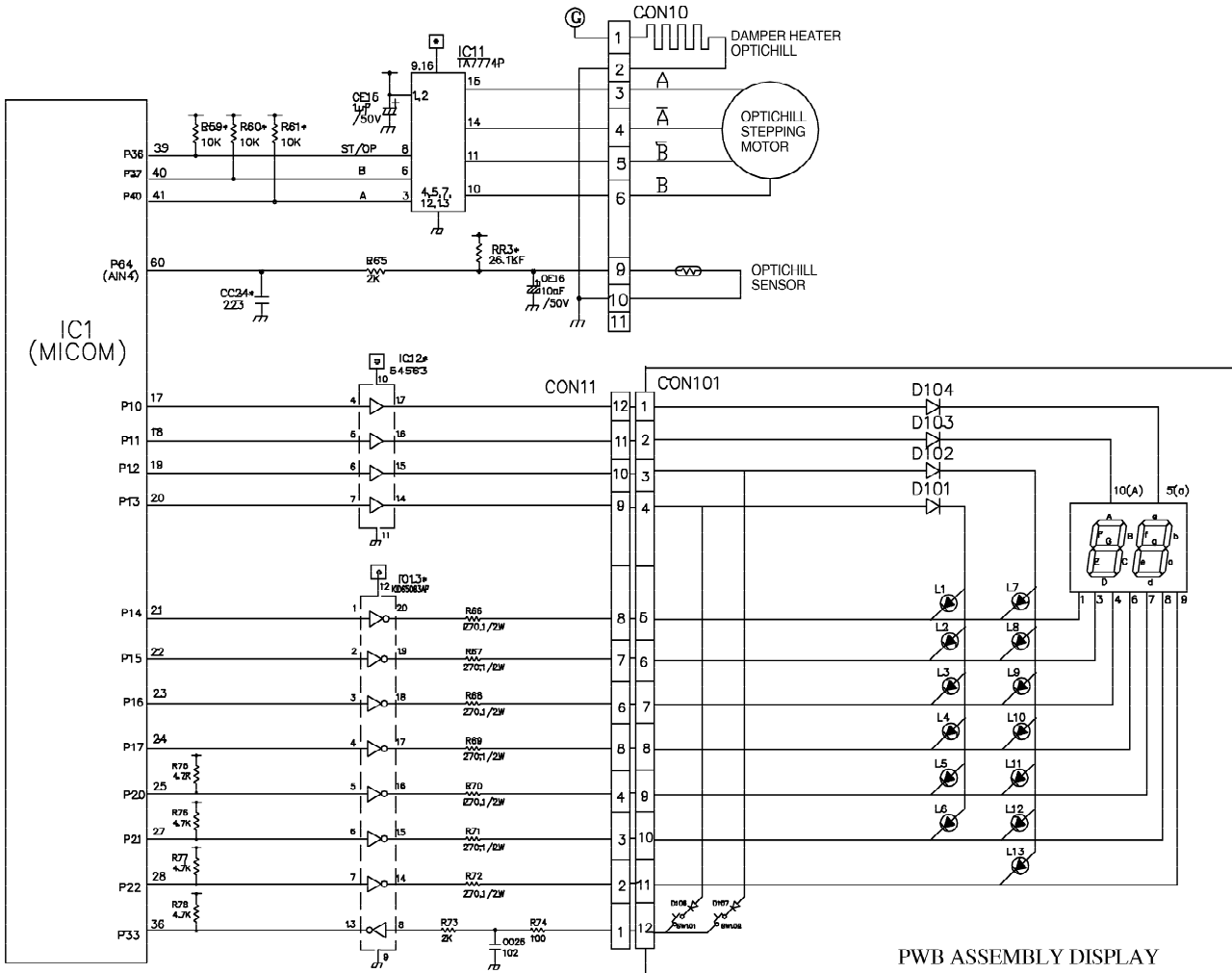

## 1-15. Jet freezing

LRSC26944\*\*, LRSC26930\*\*

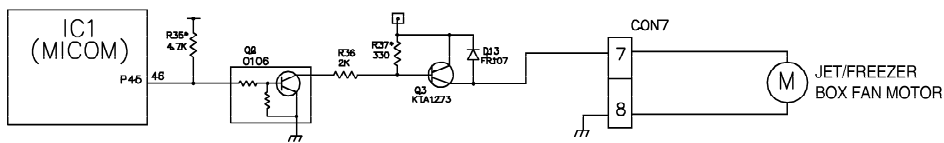

# EXPLANATION FOR MICOM CIRCUIT

## 2. PWB parts diagram and list

### 2-1. PWB Assembly, main part diagram

LRSC269\*\*\*\*

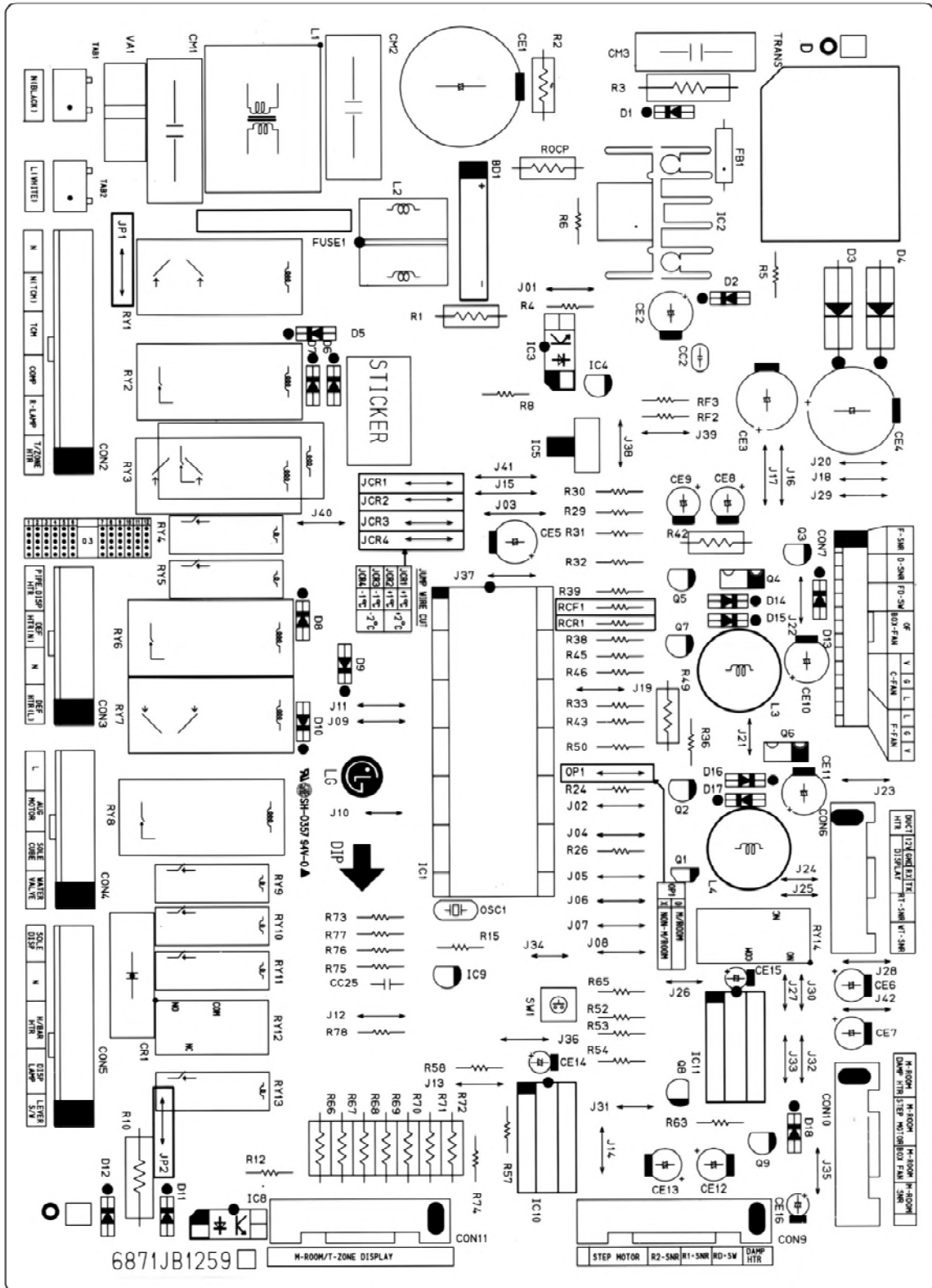

# EXPLANATION FOR MICOM CIRCUIT

## 2-2. Parts list

LRSC269\*\*\*\*

D	C	B	A	WORK	CH-PJT SET PARTS SET FILES	CH-PJT DLX	CH-PJT BEST	APP LICATION	Qty	Qty	Qty	No	P/NO	DESCRIPTION	SPEC	MAKER	REMARK
-	-	1	1	1	-	-	-						8870JB8112A	PWB(PCB)	CH-PJT BEST/DLX	DDD SAN	T=18
-	-	1	1	2	-	-	-						8870JB8112B	PWB(PCB)	CH-PJT BETTERT-3	DDD SAN	T=18
-	-	1	1	6	-	-	-						6170JB2013C	TRANSFORMER,SMPSTCOIL	12V11.5 16V1 (220 NARROW)	SAM IL	TRANS
-	-	1	1	4	-	-	-						6170JB2013D	TRANSFORMER,SMPSTCOIL	12V11.5 16V1 (110 NARROW)	SAM IL	TRANS
-	-	1	1	1	5	-	-						6630VM0380B	CONNECTOR (CIRC),WAFER	YW396-53V(SP-3)	YEON HO	C0N1
-	-	1	1	1	6	-	-						6630VM01111	CONNECTOR (CIRC),WAFER	YW396 YCONHO 11P 3.96MM YW396-11AV (1P-P4,6,8,10)	YEON HO	C0N2
-	-	1	1	1	7	-	-						6630VM0260Y	CONNECTOR (CIRC),WAFER	YW396-09AV(9P-E,4,6,8)	YEON HO	C0N5
-	-	1	1	1	8	-	-						6630VM04007	CONNECTOR (CIRC),WAFER	YW396-07AV(7P-P4,6) RED	YEON HO	C0N3(RED)
-	-	1	1	1	9	-	-						6630VM02707	CONNECTOR (CIRC),WAFER	YW396-07AV(7P-E,4,6)	YEON HO	C0N4
-	-	1	1	1	10	-	-						6630JB8007E	CONNECTOR (CIRC),WAFER	917784-1 AMP 6P 2.5MM STRAIGHT SN	AMP	C0N8
-	-	1	1	1	11	-	-						6630JB8007G	CONNECTOR (CIRC),WAFER	917786-1 AMP 8P 2.5MM STRAIGHT SN	AMP	C0N7
-	-	1	1	1	12	-	-						6630JB8007J	CONNECTOR (CIRC),WAFER	917788-1 AMP 10P 2.5MM STRAIGHT SN	AMP	C0N6
-	-	1	1	1	13	-	-						6630JB8007K	CONNECTOR (CIRC),WAFER	917789-1 AMP 11P 2.5MM STRAIGHT SN	AMP	C0N10
-	-	1	1	1	14	-	-						6630JB8007L	CONNECTOR (CIRC),WAFER	917790-1 AMP 12P 2.5MM STRAIGHT SN	AMP	C0N11
-	-	1	1	1	15	-	-						6630JB8010A	CONNECTOR (CIRC),WAFER	917791-1 AMP 13P 2.5MM STRAIGHT SN	AMP	C0N9
-	-	1	1	1	16	-	-						01ZZJB2030C	IC,DRAWING	IMP87PM41N 64 SDIP ST CH-PJT BEST/BETTER-3 MASK	TOSHIBA	IC1(=01ZZJB2030D)
-	-	1	1	1	17	-	-						01ZZJB2030E	IC,DRAWING	IMP87PM41N 64 SDIP ST CH-PJT NAESU MASK	TOSHIBA	IC1(=01ZZJB2030F)
-	-	1	1	1	18	-	-						01PMGSK001A	IC,POWER MANAGEMENT	STR-08351 SANKEN 5P S1	SANKEN	IC2
-	-	2	2	2	19	-	-						01PMGNE001A	IC,POWER MANAGEMENT	PS2961-1 NEC 4P,DIP BK = 11P/62JF	NEC	IC3,8
-	-	1	1	1	20	-	-						01KE431000A	IC,KEC	K1A431 3 PIN TP - - -	KEC	IC4
-	-	1	1	1	21	-	-						01KE780800Z	IC,KEC	K1A7805P1 - - - -	KEC	IC5
-	-	2	2	2	22	-	-						01KE600030C	IC,KEC	K1D65003AF 18SDP BK 7CH DRIVER	KEC	IC6,7
-	-	1	1	1	23	-	-						01KE650830B	IC,KEC	K1D65083AF 20SDP BK 8CH DRIVER	KEC	IC13(M/ROOM)
-	-	1	1	1	24	-	-						01KE704200A	IC,KEC	K1A7042P 3P BK RESET -	KEC	IC9
-	-	1	1	1	25	-	-						01T0777400A	IC,TOSHIBA	TA7774AP 18,SDIP BK DRIVE,IC STEPPING MOTOR	TOSHIBA	IC10
-	-	1	1	1	26	-	-						01T0777400B	IC,TOSHIBA	TA7774AP 18,SDIP BK DRIVE,IC STEPPING MOTOR	TOSHIBA	IC11(M/ROOM)
-	-	1	1	1	27	-	-						01STLMI001A	IC,STANDARD LOGIC	M54962FP MITSUBISHI 20 R/TP CONVERT	MITSUBISHI	IC12(M/ROOM)
-	-	1	1	1	28	-	-						0920ALZ001A	RELAY	ALZ12B12 NAIS 250VAC 18A 12VDC IC NO VENTING	MATSUSHITA	RY1(CMD)
-	-	1	1	1	29	-	-						0920JB2004D	RELAY	DH1201-0-0 (JAPAN) DEC 250VAC 10A 12VDC 1A NO VENT	DAICHI	RY3(R_LAMP)
-	-	3	3	3	30	-	-						09P0000001A	RELAY	AI F15B12 MATSUSHITA 250VAC 18A 12VDC 1A NO VENTING	MATSUSHITA	RY2,RY6,RY8
-	-	1	1	1	31	-	-						0920AI Z001A	RELAY	AI Z12B12 NAIS 250VAC 18A 12VDC IC NO VENTING	MATSUSHITA	RY3(R_LAMP)
-	-	1	1	1	32	-	-						0920ALZ001A	RELAY	ALZ12B12 NAIS 250VAC 18A 12VDC IC NO VENTING	MATSUSHITA	RY7
-	-	4	4	4	33	-	-						0920JB2003C	RELAY	ALD12 MATSUSHITA 250VAC 3A 12VDC 1A	MATSUSHITA	RY5,9,10,11
-	-	1	1	1	34	-	-						0920JB2003C	RELAY	ALD12 MATSUSHITA 250VAC 3A 12VDC 1A	MATSUSHITA	RY13(DISP_LAMP)
-	-	1	1	1	35	-	-						0920JB2003C	RELAY	ALD12 MATSUSHITA 250VAC 3A 12VDC 1A	MATSUSHITA	RY4(M/ROOM)
-	-	1	1	1	36	-	-						0920LJ2009A	RELAY	LES-1 DIMRN 12V 5A 277V IC	JIMRON	RY4
-	-	1	1	1	37	-	-						0920LJ2009A	RELAY	GSS-1 DIMRN 12V 5A 277V IC	JIMRON	RY12(GH/BAR)
-	-	1	1	1	38	-	-						0912W54002A	RESONATOR,CERAMIC	CST50400 MURATA 4MHz +/-0.5% TP 15PF	MURATA	OSC1
-	-	1	1	1	39	-	-						0102JB8001A	VARIABLE	SVCG21D-14A SAMWHA UL/VDE BK 620V	SAM WHA,IL JIN	VA1
-	-	1	1	1	40	-	-						0102W5V008A	VARIABLE	SVCG21D-14A SAMWHA UL/CSA/VDE TP 270V	SAM WHA,IL JIN	VA1
-	-	6	6	6	41	-	-						0D107009AA	DIODE,RECTIFIERS	FR107 TP DELTA DD41 1000V 1A 3	DELTA	DL2,14-17
-	-	1	1	1	42	-	-						0D107009AA	DIODE,RECTIFIERS	FR107 TP DELTA DD41 1000V 1A 3	DELTA	DL3(C0F)
-	-	1	1	1	43	-	-						0D107009AA	DIODE,RECTIFIERS	FR107 TP DELTA DD41 1000V 1A 3	DELTA	DL8(M/ROOM)
-	-	2	2	2	44	-	-						0D1S400090A	DIODE,RECTIFIERS	RI-3 SANKEN BK NOIN 360V 3.5A 80A 50NSPEC 0.1MA	SANKEN	DL3,DL4
-	-	1	1	1	45	-	-						0D360000AA	DIODE,RECTIFIERS	D3SBA60 BK SHINDENGEN 800V 4A	SHINDENGEN	BD1
-	-	5	5	5	46	-	-						0D1400409AC	DIODE,RECTIFIERS	IN4004 TP PYUNGCHANG - - - - -	DELTA,PYUNGCHANG	DL6-U
-	-	1	1	1	47	-	-						0D1400409AC	DIODE,RECTIFIERS	IN4004 TP PYUNGCHANG - - - - -	DELTA,PYUNGCHANG	DL7(CMD)
-	-	1	1	1	48	-	-						0D1400709AA	DIODE,RECTIFIERS	IN4007 TP MOTOROLA - - - - -	DELTA,PYUNGCHANG	DL2
-	-	1	1	1	49	-	-						0DD4148098B	DIODE,SWITCHING	IN4148 TP ROHM DC15 75V 450MIL	ROHM,PYUNGCHANG	DL1
-	-	1	1	1	50	-	-						0DZRM0108A	DIODE,ZENERS	RZL RD1M R/TP LLSKCLL 34J 500MW 3.6V 20MA J/T	ROHM	ZD1
-	-	1	1	1	51	-	-						0CF4767V6F0	CAPACITOR,FIXED ELECTROLYTIC	470UF HE 450V 20% BULK SNAP IN	RUBYCON	CE1(105°C)
-	-	1	1	1	52	-	-						0CE686ZU610	CAPACITOR,FIXED ELECTROLYTIC	68UF HE 400V 20% BULK SNAP IN	RUBYCON	CE1(105°C)
-	-	1	1	1	53	-	-						0CE226ZK638	CAPACITOR,FIXED ELECTROLYTIC	220UF YX 50V 20% FMS TP 5	RUBYCON	CE2(105°C)
-	-	1	1	1	54	-	-						0CE108ZU610	CAPACITOR,FIXED ELECTROLYTIC	1000UF YXG 25V 20% BULK FL	RUBYCON	CE3(105°C)
-	-	1	1	1	55	-	-						0CE108ZU610	CAPACITOR,FIXED ELECTROLYTIC	1000UF YXG 35V 0.2 TP 5 FL	RUBYCON	CE4(105°C)
-	-	1	1	1	56	-	-						0CE2276F638	CAPACITOR,FIXED ELECTROLYTIC	220UF SMS,SQ 16V 20% FMS TP 5	RUBYCON	CE5(85°C)
-	-	6	6	6	57	-	-						0CE2276F638	CAPACITOR,FIXED ELECTROLYTIC	220UF KME TYPE 25V 20% FMS TP 5	SAM WHA	CE10,11(105°C)
-	-	6	6	6	58	-	-						0C11061K838	CAPACITOR,FIXED ELECTROLYTIC	100UF KM TYPE 50V 20% FMS TP 5	RUBYCON	CE6-9,12,13(85°C)
-	-	1	1	1	59	-	-						0CE106EK638	CAPACITOR,FIXED ELECTROLYTIC	100UF KM TYPE 50V 20% FMS TP 5	RUBYCON	CE16(85°C) (M/ROOM)
-	-	1	1	1	60	-	-						0CE1036K638	CAPACITOR,FIXED ELECTROLYTIC	100UF SMS,SQ 50V 20% FMS TP 5	RUBYCON	CE14(85°C)
-	-	1	1	1	61	-	-						0CF1054K638	CAPACITOR,FIXED ELECTROLYTIC	10UF SMS,SQ 50V 20% FMS TP 5	RUBYCON	CE15(85°C) (M/ROOM)
-	-	1	1	1	62	-	-						0CF33409670	CAPACITOR,FIXED FILM	330nF 275VAC	PILKOR	CM1
-	-	1	1	1	63	-	-						0CF22409670	CAPACITOR,FIXED FILM	220nF 275VAC	PILKOR	CM2
-	-	1	1	1	64	-	-						0C04732Y430	CAPACITOR,FIXED FILM	47000PF S 630V 5Z M/PE NI R	SEIL	CM3
-	-	1	1	1	65	-	-						0CK22102510	CAPACITOR,FIXED CERAMIC(High dielectric)	220P 2KV K B S	SAM WHA DOOSAN	CC2
-	-	1	1	1	66	-	-						0CK2240K94A	CAPACITOR,FIXED CERAMIC(High dielectric)	220NF 2012 50V 80%, -20% F(Y5V) R/TP	MURATA	CC3 (SMD)
-	-	6	6	6	67	-	-						0CK1040K94A	CAPACITOR,FIXED CERAMIC(High dielectric)	100NF 2012 50V 80%, -20% R/TP F(Y5V)	MURATA	CC4-6,8,9,11 (SMD)
-	-	12	12	12	68	-	-						0CK223DK96A	CAPACITOR,FIXED CERAMIC(High dielectric)	22NF 2012 50V 80%, -20% R/TP X7R	MURATA	CC7,10,12-17,19,21-23 (SMD)
-	-	1	1	1	69	-	-						0CK223DK96A	CAPACITOR,FIXED CERAMIC(High dielectric)	22NF 2012 50V 80%, -20% R/TP X7R	MURATA	CC24 (SMD)(M/ROOM)
-	-	1	1	1	70	-	-						0CK1020K519	CAPACITOR,FIXED CERAMIC(High dielectric)	1000PF 50V K B TASP	TAE YANG	CC25(M/ROOM)
-	-	2	2	2	71	-	-						0CK1020K96A	CAPACITOR,FIXED CERAMIC(High dielectric)	1NF 2012 50V 80%, -20% R/TP X7R	MURATA	CC18,20 (SMD)
-	-	1	1	1	71	-	-						0CK4710K96A	CAPACITOR,FIXED CERAMIC(High dielectric)	0.00047UF 2012 50V 80%, -20% R/TP X7R	MURATA	CC1 (SMD)



# EXPLANATION FOR MICOM CIRCUIT

1	1	1	1	78	ORS3303J609	RESISTOR, FIXED METAL OXIDE FILM	330K OHM 1/4 W 5% TASP	SMART, CHOHYANG	R1
1	1	1	1	73	ORD5603H809	RESISTOR, FIXED CARBON FILM	560K OHM 1/2 W 5.00% TASP	SMART, CHOHYANG	R2
1	1	1	1	74	ORS5602K841	RESISTOR, FIXED METAL OXIDE FILM	56K OHM 2 W 5.00% F20	SMART, CHOHYANG	R3
1	1	1	1	79	ORDA801G609	RESISTOR, FIXED CARBON FILM	6.8K OHM 1/4 W 5.00% TASP	SMART, CHOHYANG	R4
1	1	-	1	76	ORDI2000G09	RESISTOR, FIXED CARBON FILM	120 OHM 1/4 W 5.00% TASP	SMART, CHOHYANG	R5
-	-	1	-	77	ORD0822Q609	RESISTOR, FIXED CARBON FILM	82 OHM 1/4 W 5.00% TASP	SMART, CHOHYANG	R5
1	1	1	1	78	ORD8800G609	RESISTOR, FIXED CARBON FILM	880 OHM 1/4 W 5.00% TASP	SMART, CHOHYANG	R8
1	1	-	1	79	ORW0470J609	RESISTOR, FIXED POWER COATED WIRE-WOUND	0.47 OHM 1 W 5% TASP	SMART, CHOHYANG	R10CP
-	-	-	-	80	ORW0580J809	RESISTOR, FIXED POWER COATED WIRE-WOUND	0.56 OHM 1 W 5% TASP	SMART, CHOHYANG	R10CP
-	-	1	-	81	ORW0101J609	RESISTOR, FIXED POWER COATED WIRE-WOUND	1 OHM 1 W 5% TASP	SMART, CHOHYANG	R10CP
1	1	1	1	82	ORDI801G609	RESISTOR, FIXED CARBON FILM	1.8K OHM 1/4 W 5.00% TASP	SMART, CHOHYANG	R8
1	1	1	1	83	ORDI001G609	RESISTOR, FIXED CARBON FILM	1K OHM 1/4 W 5.00% TASP	SMART, CHOHYANG	R28
1	1	1	1	84	ORN9101G409	RESISTOR, FIXED METAL FILM	9.1K OHM 1/4 W 1.00% TASP	SMART, CHOHYANG	R12?
1	1	1	1	85	ORN2401G409	RESISTOR, FIXED METAL FILM	2.4K OHM 1/4 W 1.00% TASP	SMART, CHOHYANG	R13
1	1	1	1	88	ORS5602K841	RESISTOR, FIXED METAL OXIDE FILM	56K OHM 2 W 5.00% F20	SMART, CHOHYANG	R10
3	3	3	3	87	ORDI002G609	RESISTOR, FIXED CARBON FILM	10K OHM 1/4 W 5.00% TASP	SMART, CHOHYANG	R12,57,58
4	4	4	4	88	ORD4701G609	RESISTOR, FIXED CARBON FILM	4.7K OHM 1/4 W 5.00% TASP	SMART, CHOHYANG	R15,24,38,45
-	-	4	4	89	ORD4701G609	RESISTOR, FIXED CARBON FILM	4.7K OHM 1/4 W 5.00% TASP	SMART, CHOHYANG	R73~78M/ROOM
10	10	10	10	90	ORD2001G609	RESISTOR, FIXED CARBON FILM	2K OHM 1/4 W 5.00% TASP	SMART, CHOHYANG	R29~33,43,50,52~64
-	-	1	1	91	ORD2001G609	RESISTOR, FIXED CARBON FILM	2K OHM 1/4 W 5.00% TASP	SMART, CHOHYANG	R38(QF)
-	-	3	3	92	ORD2001G609	RESISTOR, FIXED CARBON FILM	2K OHM 1/4 W 5.00% TASP	SMART, CHOHYANG	R63,65,73M/ROOM
2	2	2	2	93	ORD3901G609	RESISTOR, FIXED CARBON FILM	3.9K OHM 1/4 W 5.00% TASP	SMART, CHOHYANG	R39,46
2	2	2	2	94	ORD1601G609	RESISTOR, FIXED CARBON FILM	1.6K OHM 1/2 W 5.00% TASP	SMART, CHOHYANG	R42,49
-	-	1	1	95	ORDI000G609	RESISTOR, FIXED CARBON FILM	100 OHM 1/4 W 5% TASP	SMART, CHOHYANG	R74M/ROOM
1	1	1	1	96	ORH1001L622	RESISTOR, METAL GLAZED(CHIP)	100 OHM 1 / 8 W 5% 2012 R/TP	ROHM	R11
1	1	1	1	97	ORH1001L622	RESISTOR, METAL GLAZED(CHIP)	10 OHM 1 / 8 W 2012 5.00% D	ROHM	R13
11	11	11	11	98	ORH1002L822	RESISTOR, METAL GLAZED(CHIP)	10K OHM 1/8 W 5% 2012 R/TP	ROHM	R18~23,40,47,56
-	-	3	3	99	ORH1002L822	RESISTOR, METAL GLAZED(CHIP)	10K OHM 1/8 W 5% 2012 R/TP	ROHM	R59~61M/ROOM
3	3	3	3	100	ORH2001L622	RESISTOR, METAL GLAZED(CHIP)	2K OHM 1 / 8 W 2012 5.00% D	ROHM	R27,34,53
6	6	6	6	101	ORH4701L622	RESISTOR, METAL GLAZED(CHIP)	4.7K OHM 1 / 8 W 2012 5.00% D	ROHM	R14,25,28,36,44,51
-	-	1	1	102	ORH4701L622	RESISTOR, METAL GLAZED(CHIP)	4.7K OHM 1 / 8 W 2012 5.00% D	ROHM	R82M/ROOM
2	2	2	2	103	ORH3300L622	RESISTOR, METAL GLAZED(CHIP)	330 OHM 1 / 8 W 2012 5.00% D	ROHM	R41,48
-	-	1	1	104	ORH3300L622	RESISTOR, METAL GLAZED(CHIP)	330 OHM 1 / 8 W 2012 5.00% D	ROHM	R37(QF)
-	-	1	1	105	ORH3300L622	RESISTOR, METAL GLAZED(CHIP)	330 OHM 1 / 8 W 2012 5.00% D	ROHM	R64M/ROOM
1	1	1	1	106	ORH1001L622	RESISTOR, METAL GLAZED(CHIP)	1K OHM 1/8 W 5% 2012 R/TP	ROHM	R9
1	1	1	1	107	ORDI002G609	RESISTOR, FIXED CARBON FILM	10K OHM 1/4 W 5.00% TASP	SMART, CHOHYANG	RCR1
-	-	-	-	108	ORDI202G609	RESISTOR, FIXED CARBON FILM	12K OHM 1/4 W 5.00% TASP	SMART, CHOHYANG	RCR1
-	-	-	-	109	ORD8201G609	RESISTOR, FIXED CARBON FILM	8.2K OHM 1/4 W 5.00% TASP	SMART, CHOHYANG	RCR1
1	1	1	1	110	ORDI002G609	RESISTOR, FIXED CARBON FILM	10K OHM 1/4 W 5.00% TASP	SMART, CHOHYANG	RC1
1	1	1	1	111	ORH1002L422	RESISTOR, METAL GLAZED(CHIP)	10K OHM 1/8 W 1% 2012 R/TP	ROHM	RT1
1	1	1	1	112	ORJ822E472	RESISTOR, METAL GLAZED(CHIP)	18.2K OHM 1 / 8 W 2012 1.00% D	ROHM	RF1
4	4	4	4	113	ORJ261E472	RESISTOR, METAL GLAZED(CHIP)	26.1K OHM 1 / 8 W 2012 1.00% D	ROHM	RD1,RR1,RR2,RW1
-	-	1	1	114	ORJ261E472	RESISTOR, METAL GLAZED(CHIP)	26.1K OHM 1 / 8 W 2012 1.00% D	ROHM	RR3M/ROOM
-	-	7	7	115	ORD2700H609	RESISTOR, FIXED CARBON FILM	270 OHM 1/2 W 5.00% TASP	SMART, CHOHYANG	R66~72M/ROOM
2	2	2	2	116					
2	2	2	2	117	OTRKF00008A	TRANSISTOR, BIPOLARS	KFC KT1151 BK T1126 60V 5A	KFC	Q4,Q6
2	2	2	2	118	OTR319809CA	TRANSISTOR	KTC3198-TP-Y (KTC1916)KFC	KFC	Q5,Q7
1	1	1	1	119	OTR10809AF	TRANSISTOR, BIPOLARS	KRC 106M KEC	KEC	Q1
-	-	1	1	120	OTR10809AF	TRANSISTOR, BIPOLARS	KRC 106M KEC	KEC	Q2(QF)
-	-	1	1	121	OTR10809AF	TRANSISTOR, BIPOLARS	KRC 106M KEC	KEC	Q8M/ROOM
1	1	1	1	122	OTR127309AD	TRANSISTOR	KT1273-Y (KTA966A) TP KEC --	KEC	Q9
-	-	1	1	123	OTR127309AD	TRANSISTOR	KT1273-Y (KTA966A) TP KEC --	KEC	Q3(QF)
1	1	1	1	124	6210 JB8001A	FILTER(CIRC),EMC	BF3510A0 SAMWHA 52 -	SAM_WHA	FB1
1	1	1	1	125	6600R1001W	SWITCH, TACT	THV5012P66A PINSTECH 12V DC 50MA TAPING	PINSTECH	SW1
42	42	42	42	126	6854B50001A	JUMP WIRE	0.6MM 52MM TP TAPING SN	DAE A LEAD	J01~J42
4	4	4	4	127	6854B50001A	JUMP WIRE	0.6MM 52MM TP TAPING SN	DAE A LEAD	JCR1~JCR4
-	-	1	1	128	6854B50001A	JUMP WIRE	0.6MM 52MM TP TAPING SN	DAE A LEAD	DP1M/ROOM
1	1	1	1	129	6854B50001A	JUMP WIRE	0.6MM 52MM TP TAPING SN	DAE A LEAD	JP1
-	-	1	-	130	6854B50001A	JUMP WIRE	0.6MM 52MM TP TAPING SN	DAE A LEAD	JPP
1	1	1	1	131	6200 JB8001B	FILTER(CIRC),EMC	120+0.1UF P1L KDR --	P1L KDR	CR1
1	1	1	1	132	6200 JB8009B	FILTER(CIRC),EMC	CH940050 TNC BK	TNC	I,2
1	1	1	1	133	6200 JB8007X	FILTER(CIRC),EMC	UV11-05320 TNC BK 0.6A 32MH	TNC	I,1
2	2	2	2	134	01R101M4FD	INDUCTOR,RADIAL LEAD	1000UH 20% R AX12.5 BULK	TNC	I,3,4
1	1	1	1	135	0F5S001B502	FUSE,SLOW BLOW	5000MA 250 V 3.2X20 LD/GL UL / CSA	SAM JU	FUSE1
1	1	1	1	136	4920 JB3007A	HEAT SINK	23.3*17*25 DRIVE IC STR R-S64,86,73 PPIN 1-SCREW 3MM	TAE SUNG	(IC2)
1	1	1	1	137	1S BF0302418	SCREW	+ D3.0 L8.0 MSVR3/FZY	-	(IC2)
138	138	138	138	138	9VWF0120000	SOLDER(ROBIN WIRE) R50	DL20	-	-
139	139	139	139	139	49111004	SOLDER,SOLDERING	H63A	HI SUNG	-
140	140	140	140	140	59333105	FLUX	SG0.825-0.830 KOREA F.H-P08	KOKI	-

# EXPLANATION FOR MICOM CIRCUIT

## 2-3. LRSC26944\*\*, LRSC26980TT DISPLAY ASSEMBLY part diagram

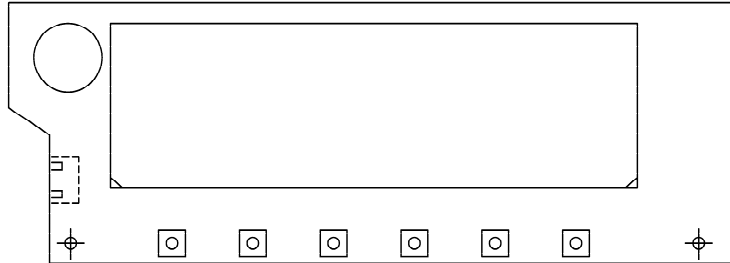

E		D		C		B		A		WORK	P/NO	DESCRIPTION	SPEC	MAKER	REMARK
CP2-PJT	EU	CP2-PJT	DLX	CP2-PJT	DLX	CP2-PJT	DLX	CP2-PJT	DLX	APPLICAITON					
ENGLISH	ENGLISH	ENGLISH	ENGLISH	ENGLISH	ENGLISH	ENGLISH	ENGLISH	ENGLISH	ENGLISH						
1A	1B	1A	1B	1A	1B	1A	1B	1A	1B	No					
										1	6304TKN003	LCD(LIQUID CRYSTAL DISPLAY)	KONECS TN M0NP CD2/CH DLX (A:JHK1149,B:JHK1200)	KONECS	-
										2					
										3					
										4		PWB	FR-4		
										5		REFLECTOR	PC ABS		
										6		확산 SHEET	MTN-WX5(47.25*164MM)		투과율35%
										7		WAFER	SMAW250-04	YEON-HO	CON101
										8					
										9					
										10					
										11	01ZZJB2029	IC,DRAWING	TMP87CH21F 80,QFP BK CD2/CH-PJT BASIC/DLX	TOSHIBA	IC101(KC=D,E=F)
										12					
										13	01STLKE002A	IC,STANDARD LOGIC	KIA78L05F KEC SOT-89 TP REGULATOR	KEC	IC102
										14	01STLKE003A	IC,STANDARD LOGIC	KIA7042AF KEC SOT-89 TP RESET IC	KEC	IC103
										15	01RH934600A	IC,RDHM	BR93LC46RF-W 8PIN SOP BK EEPROM	ROHM	IC104
										16	01STLKE004A	IC,STANDARD LOGIC	KRA106S KEC SOT-23 TP TRANSISTOR	KEC	Q108
										17	01STLKE005A	IC,STANDARD LOGIC	KRC106S KEC SOT-23 TP TRANSISTOR	KEC	Q101~Q105
										18	01STLKE006A	IC,STANDARD LOGIC	KTA1298 KEC SOT-23 TP TRANSISTOR	KEC	Q106,Q107
										19					
										20					
										21	6212W5M002A	RESONATOR,CERAMIC	CSTS0400 MURATA 4MHZ +/-0.5% TP 15PF	MURATA	DSC101
										22					
										23					
										24					
										25	0CE107VF6DC	CAPACITOR,FIXED ELECTROLYTIC	100UF MV 16V 20% R/TP(SMD) SMD	RUBYCON	CE101,CE102
										26					
										27	0CE476VH6DC	CAPACITOR,FIXED ELECTROLYTIC	47UF MV 25V 20% R/TP(SMD) SMD	RUBYCON	CE103
										28					
										29	0CK104DK94A	CAPACITOR,FIXED CERAMIC(HIGH	100NF 2012 50V 80%,-20% R/TP F(Y5V)	MURATA	CC101~CC108
										30					
										31					
										32	0RJ1000G676	RESISTOR,METAL GLAZED(CHIP)	100 OHM 1/4 W 5% 3216 R/TP	ROHM	
										33	0RJ2200E672	RESISTOR,METAL GLAZED(CHIP)	220 OHM 1/8 W 5% 2012 R/TP	ROHM	R154
										34	0RJ4700G676	RESISTOR,METAL GLAZED(CHIP)	470 OHM 1/4 W 5% 3216 R/TP	ROHM	R126~R151
										35	0RJ6800G676	RESISTOR,METAL GLAZED(CHIP)	680 OHM 1/4 W 5% 3216 R/TP	ROHM	R152,R153
										36					
										37	0RJ5600E472	RESISTOR,METAL GLAZED(CHIP)	560 OHM 1/8 W 1% 2012 R/TP	ROHM	R124
										38	0RJ1001E672	RESISTOR,METAL GLAZED(CHIP)	1K OHM 1/8 W 5% 2012 R/TP	ROHM	R104,105
										39	0RJ2001E672	RESISTOR,METAL GLAZED(CHIP)	2K OHM 1/8 W 5% 2012 R/TP	ROHM	R101-103
										40	0RJ4701E672	RESISTOR,METAL GLAZED(CHIP)	4.7K OHM 1/8 W 5% 2012 R/TP	ROHM	R108-122
										41	0RJ1502E672	RESISTOR,METAL GLAZED(CHIP)	15K OHM 1/8 W 5% 2012 R/TP	ROHM	R106,R107
										42	0RJ1004E672	RESISTOR,METAL GLAZED(CHIP)	10K OHM 1/8 W 5% 2012 R/TP	ROHM	R125
										43	0RJ4702E672	RESISTOR,METAL GLAZED(CHIP)	47K OHM 1/8 W 5% 2012 R/TP	ROHM	
										44	0RJ1201E472	RESISTOR,METAL GLAZED(CHIP)	1.2K OHM 1/8 W 1% 2012 R/TP	ROHM	<del>R124</del>
										45	0RJ1002E472	RESISTOR,METAL GLAZED(CHIP)	10K OHM 1/8 W 1% 2012 R/TP	ROHM	R123
										46	0DZRM00188A	DIODE,ZENERS	RLZ ROHM R/TP LLDS(LL-34) 500MW 5.6V 20	ROHM	ZD101
										47		WIRE,JUMP			DP1
										48		WIRE,JUMP			DP2
										49		WIRE,JUMP			DP3
										50	6908JB8003A	BUZZER	BM-20B BUJEDN PIEZO 4KHZ 85DB	BUJEDN	BUZZER
										51	6600RRT002J	SWITCH,TACT	JTP1138A JEIL 12VDC 50MA SMD	JEIL	SW101-SW106
		110								52	0DL SU0068AA 0DLLE0038AA	LED	SEDUL SEMICDN SSCUY101 R/TP AMBER - LEDTECH LT8B32-UR-191T R/TP AMBER 35MCD	SEDUL-SEMICDN LEDTECH	LD101~LD210
110	110					110				53	0DL SU0029AA 0DLLE0048AA	LED	SEDUL SEMICDN SSC570YG TP GREEN/YELLOW LEDTECH LT8B22-J-190T R/TP GREEN/YELLOW	SEDUL-SEMICDN LEDTECH	LD101~LD210
										54	0DL SU0068AA	LED	SEDUL SEMICDN SSCUY101 R/TP AMBER -	SEDUL-SEMICDN	LD101~LD210
										55	0DL SU0029AA	LED	SEDUL SEMICDN SSC570YG TP GREEN/YELLOW	SEDUL-SEMICDN	LD101~LD210
										56					

# EXPLANATION FOR MICOM CIRCUIT

## DISPLAY circuit diagram

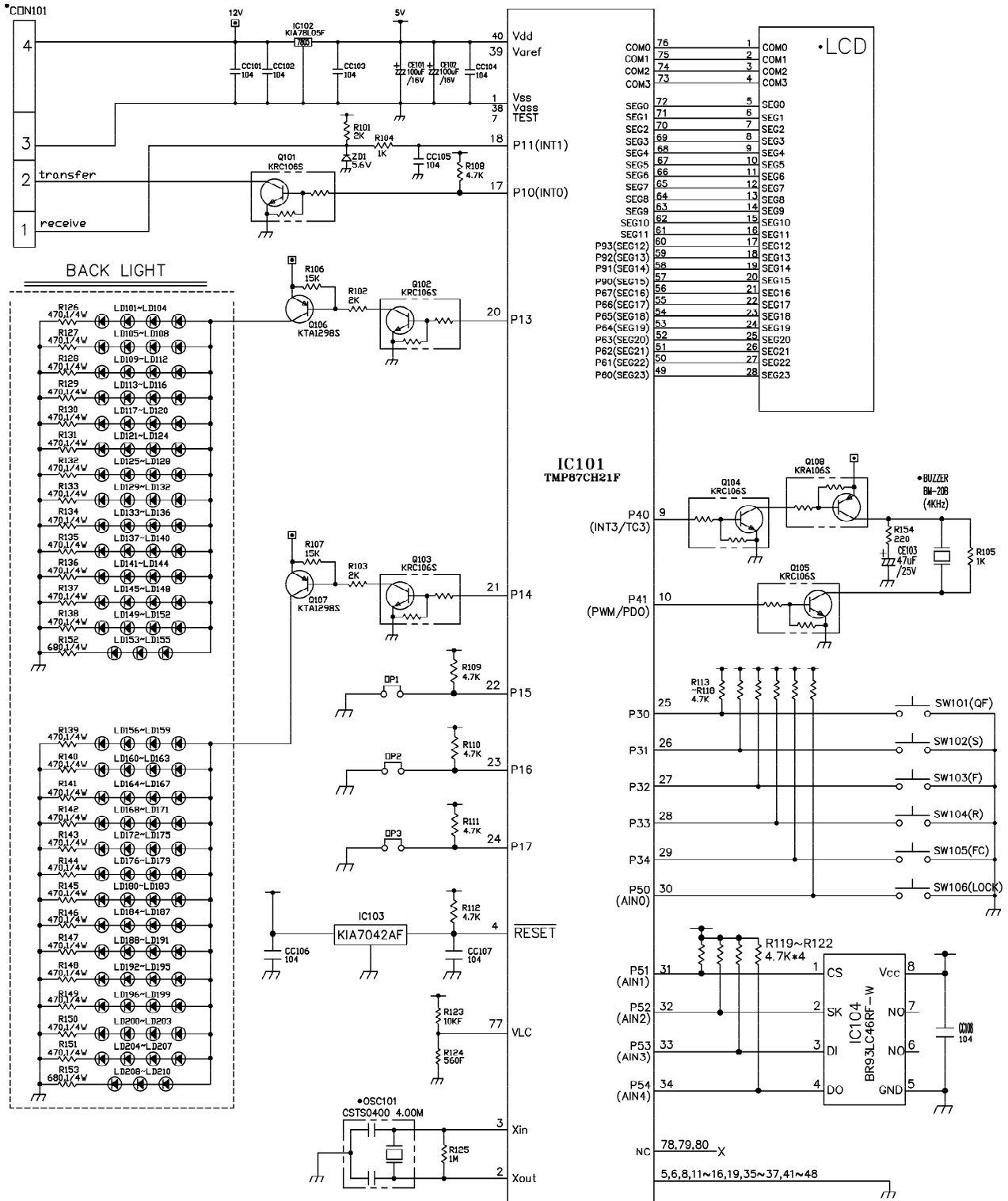

# EXPLANATION FOR MICOM CIRCUIT

2-4. LRSC26910\*\*, LRSC26911\*\*, LRSC26920\*\*, LRSC26922\*\*, LRSC26930\*\*

DISPLAY ASSEMBLY part diagram

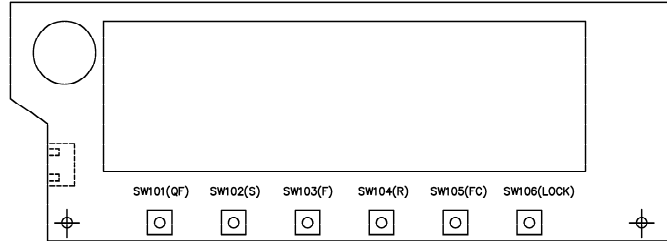

F	D	C	B	A	VORR									
CH-PJT_BLK	CH-PJT_BLK	CH-PJT_BLK	CH-PJT_BLK	CH-PJT_BLK	CH-PJT_BLK	CH-PJT_BLK	CH-PJT_BLK	CH-PJT_BLK	CH-PJT_BLK	CH-PJT_BLK	CH-PJT_BLK	CH-PJT_BLK	CH-PJT_BLK	
NAESU(OP)	NAESU(OP)	NAESU(OP)	NAESU(OP)	NAESU(OP)	NAESU(OP)	NAESU(OP)	NAESU(OP)	NAESU(OP)	NAESU(OP)	NAESU(OP)	NAESU(OP)	NAESU(OP)	NAESU(OP)	
EXPORT(GP)	EXPORT(GP)	EXPORT(GP)	EXPORT(GP)	EXPORT(GP)	EXPORT(GP)	EXPORT(GP)	EXPORT(GP)	EXPORT(GP)	EXPORT(GP)	EXPORT(GP)	EXPORT(GP)	EXPORT(GP)	EXPORT(GP)	
USA(OP)	USA(OP)	USA(OP)	USA(OP)	USA(OP)	USA(OP)	USA(OP)	USA(OP)	USA(OP)	USA(OP)	USA(OP)	USA(OP)	USA(OP)	USA(OP)	
USA(OP)	USA(OP)	USA(OP)	USA(OP)	USA(OP)	USA(OP)	USA(OP)	USA(OP)	USA(OP)	USA(OP)	USA(OP)	USA(OP)	USA(OP)	USA(OP)	
APPICATION	APPICATION	APPICATION	APPICATION	APPICATION	APPICATION	APPICATION	APPICATION	APPICATION	APPICATION	APPICATION	APPICATION	APPICATION	APPICATION	
Qty	Qty	Qty	Qty	Qty	Qty	No	P/NO	DESCRIPTION	SPEC	MAKER	REMARK	Qty	Qty	
-	-	-	-	-	-	1		PWB(PCB)	03 USA MODULE DISPLAY PCB	DOOSAN	FR4	-	-	
1	1	1	1	1	1	2		PWB(PCB)	03 NAESU/EXPORT MODULE DISPLAY PCB	DOOSAN	FR4	-	-	
-	-	-	-	-	-	3		REFLECTOR	03 USA PC-ABS	SEJUL	-	-	-	
1	1	1	1	1	4			REFLECTOR	03 NAESU/EXPORT PC-ABS	SEJUL	-	-	-	
-	-	-	-	-	-	5	4140JB1028A	NAME PLATE(PCH)	03 CH-PJT QF/JET MODULE USA	SEJUL	-	-	-	
-	-	-	-	-	-	6	4140JB1028B	NAME PLATE(PCH)	03 CD2-PJT/CH-PJT QF MODULE USA	SEJUL	-	-	-	
-	-	-	-	-	-	7	4140JB1028C	NAME PLATE(PCH)	03 CH-PJT QF/JET MODULE EXPORT	SEJUL	-	-	-	
-	-	-	-	-	-	8	4140JB1028D	NAME PLATE(PCH)	03 CD2-PJT/CH-PJT QF MODULE EXPORT	SEJUL	-	-	-	
-	-	-	-	-	-	9	4140JB1028F	NAME PLATE(PCH)	03 CH-PJT QF/JET MODULE NAESU	SFOUJ	-	-	-	
1	1	1	1	1	10		4140JB1028F	NAME PLATE(PCH)	03 CH-PJT QF MODULE NAESU	SFOUJ	-	-	-	
1	1	1	1	1	11		6630JB8005C	CONNECTOR (CIRC),WAFER	SMAW250-04	YEON HD	CON101	-	-	
-	-	-	-	-	-	12						-	-	
1	1	1	1	1	13		01Z7JB2036Q	IC,DRAWING	TMFB7CH47U 44P,QFP44-P-1010 TRAY CH-PJT USA	TOSHIBA	IC101(Q=R)	-	-	
-	-	-	-	-	-	14						-	-	
-	-	-	-	-	-	15						-	-	
-	-	-	-	-	-	16						-	-	
-	-	-	-	-	-	17						-	-	
-	-	-	-	-	-	18						-	-	
-	-	-	-	-	-	19						-	-	
1	1	1	1	1	20		01STLM1001A	IC,STANDARD LOGIC	M54563FP MITSUBISHI 20 R/TP CONVERT	MITSUBISHI	IC105	-	-	
2	2	2	2	2	21		01KE650030C	IC,KEC	KID65003AF 16SDP BK 7CH DRIVER	KEC	IC106,107	-	-	
-	-	-	-	-	-	22						-	-	
1	1	1	1	1	23		01STLKE002A	IC,STANDARD LOGIC	KIA78L05F KEC SOT-89 TP REGULATOR	KEC	IC102	-	-	
1	1	1	1	1	24		01STLKE003A	IC,STANDARD LOGIC	KIA7042AF KEC SOT-89 TP RESET IC	KEC	IC103	-	-	
1	1	1	1	1	25		01RH934600D	IC,RUHM	BR93LC46RF -W 8PIN SDP BK EEPROM	RUHM	IC104	-	-	
1	1	1	1	1	26		01STLKE004A	IC,STANDARD LOGIC	KRA106S KEC SOT-23 TP TRANSISTOR	KEC	Q104	-	-	
3	3	3	3	3	27		01STLKE005A	IC,STANDARD LOGIC	KRC106S KEC SOT-23 TP TRANSISTOR	KEC	Q101-103	-	-	
-	-	-	-	-	-	28						-	-	
-	-	-	-	-	-	29						-	-	
-	-	-	-	-	-	30						-	-	
1	1	1	1	1	31		6212BB3245A	RESONATOR,CERAMIC	CSTCR4M00G53-R0 MURATA 4.0MHZ +/- 0.5% T/R SMD	MURATA	OSC101	-	-	
-	-	-	-	-	-	32						-	-	
2	2	2	2	2	33		0CE107VF6DC	CAPACITOR,FIXED ELECTR	100UF MV 16V 20% R/TP(SMD) SMD	SAMHWA	CE101,102	-	-	
1	1	1	1	1	34		0CE476VF6DC	CAPACITOR,FIXED ELECTR	47UF MV 16V 20% R/TP(SMD) SMD	SAMHWA	CE103	-	-	
-	-	-	-	-	-	35						-	-	
-	-	-	-	-	-	36						-	-	
8	8	8	8	8	37		0CK104DK94A	CAPACITOR,FIXED CERAMI	100NF 2012 50V 90% -20% R/TP (V5V)	MURATA	CC101-108	-	-	
1	1	1	1	1	38		0CK102DK94A	CAPACITOR,FIXED CERAMI	1NF 2012 50V 90% -20% R/TP X7R	MURATA	CC109	-	-	
1	1	1	1	1	39		0RH1000L62E	RESISTOR,METAL GLAZED	100 OHM 1 / 8 W 2012 5.00% D	ROHM	R123	-	-	
1	1	1	1	1	40		0RD2200E67E	RESISTOR,METAL GLAZED	220 OHM 1/8 W 5% 2012 R/TP	ROHM	R106	-	-	
2	2	2	2	2	41		0RD1001E67E	RESISTOR,METAL GLAZED	1K OHM 1/8 W 5% 2012 R/TP	ROHM	R102,107	-	-	
2	2	2	2	2	42		0RD2001E67E	RESISTOR,METAL GLAZED	2K OHM 1/8 W 5% 2012 R/TP	ROHM	R101,122	-	-	
6	6	6	6	6	43		0RD4701E67E	RESISTOR,METAL GLAZED	4.7K OHM 1/8 W 5% 2012 R/TP	ROHM	R103,104,108~110,125	-	-	
1	1	1	1	1	44		0RD1004E67E	RESISTOR,METAL GLAZED	1M OHM 1/8 W 5% 2012 R/TP	ROHM	R105	-	-	
-	-	-	-	-	-	45						-	-	
1	1	1	1	1	46		0RJ0682G67E	RESISTOR,METAL GLAZED	68 OHM 1 / 4 W 3216 5.00% D	ROHM	R124	-	-	
3	3	3	3	3	47		0RJ2700H680	RESISTOR,METAL GLAZED	270 OHM 1 / 2 W 5025 5.00% D	ROHM	R119-121	-	-	
7	7	7	7	7	48		0RJ3300H680	RESISTOR,METAL GLAZED	330 OHM 1 / 2 W 5025 5.00% D	ROHM	R111-117	-	-	
-	-	-	-	-	-	49		0RJ3300H680	RESISTOR,METAL GLAZED	330 OHM 1 / 2 W 5025 5.00% D	ROHM	R118	-	-
-	-	-	-	-	-	50		0RJ0000E67E	RESISTOR,METAL GLAZED	0 OHM 1/8 W 5% 2012 R/TP	ROHM	DP1(EXP/RT/NAESU)	-	-
1	1	1	1	1	51		0RJ0000E67E	RESISTOR,METAL GLAZED	0 OHM 1/8 W 5% 2012 R/TP	ROHM	DP2(CJET/EXPRESS)	-	-	
-	-	-	-	-	-	52		0RJ0000E67E	RESISTOR,METAL GLAZED	0 OHM 1/8 W 5% 2012 R/TP	ROHM	DP3(USA/EXTRA)	-	-
1	1	1	1	1	53		0JZRM00189A	DIODE,ZENERS	RLZ ROHM R/TP LLD3(LL-34) 500MW 5.6V 20MA PF	ROHM	ZD101	-	-	
6	6	6	6	6	54		0URKM00028A	DIODE,RECTIFIERS	RLR4004 ROHM R/TP SOT23 400V 1A 20A SEC 10MA	ROHM	D101~106	-	-	
6	6	6	6	6	55		0USKR00068A	DIODE,SWITCHING	RLS4148 ROHM R/TP LLD3(LL-34) 75V 450MA 2000MA	ROHM	D107-112	-	-	
-	-	-	-	-	-	56						-	-	
-	-	-	-	-	-	57		0DLLE0048AA	LED	GREEN/YELLOW(2x#E)	SEJUL	L158-173(RT)	-	-
51	51	51	51	51	58		0DLLE0048AA	LED	GREEN/YELLOW(2x#E)	SEJUL	L101-131,134-147,150-153,176,177	-	-	
-	-	-	-	-	-	59		0DLLE0048AA	LED	GREEN/YELLOW(2x#E)	SEJUL	L154-157(LAMP)	-	-
2	2	2	2	2	60		0DLLE0048AA	LED	GREEN/YELLOW(2x#E)	SEJUL	L178,179(UNL OCK)	-	-	
-	-	-	-	-	-	61		0DLLE0048AA	LED	GREEN/YELLOW(2x#E)	SEJUL	L132,133,148,149,174,175	-	-
-	-	-	-	-	-	62						-	-	
-	-	-	-	-	-	63						-	-	
1	1	1	1	1	64		6908JB8003A	BUZZER,PIEZO CERAMIC	BM-20B BUJEDIN PIEZO 4KHZ 85DB	BUJEDIN	BUZZER	-	-	
6	6	6	6	6	65		6600RRT1002J	SWITCH,TACT	JPI1138A JEIL 12VDC 50MA SMD	JEIL	SW101~106	-	-	
-	-	-	-	-	-	66						-	-	
2g	2g	2g	2g	2g	2g	67	49111001	SOLDER,SOLDERING	SOLDER(RDSIN WIRE)RSD	HUISUNG	-	-	-	
5g	5g	5g	5g	5g	5g	68	49111004	SOLDER,SOLDERING	H63A	HUISUNG	-	-	-	
1g	1g	1g	1g	1g	1g	69	59333105	FLUX	SG0.025-0.030 KOREA F.H-206	KOKI	-	-	-	
-	-	-	-	-	-	70						-	-	
-	-	-	-	-	-	71						-	-	
-	-	-	-	-	-	72						-	-	

# EXPLANATION FOR MICOM CIRCUIT

## DISPLAY circuit diagram

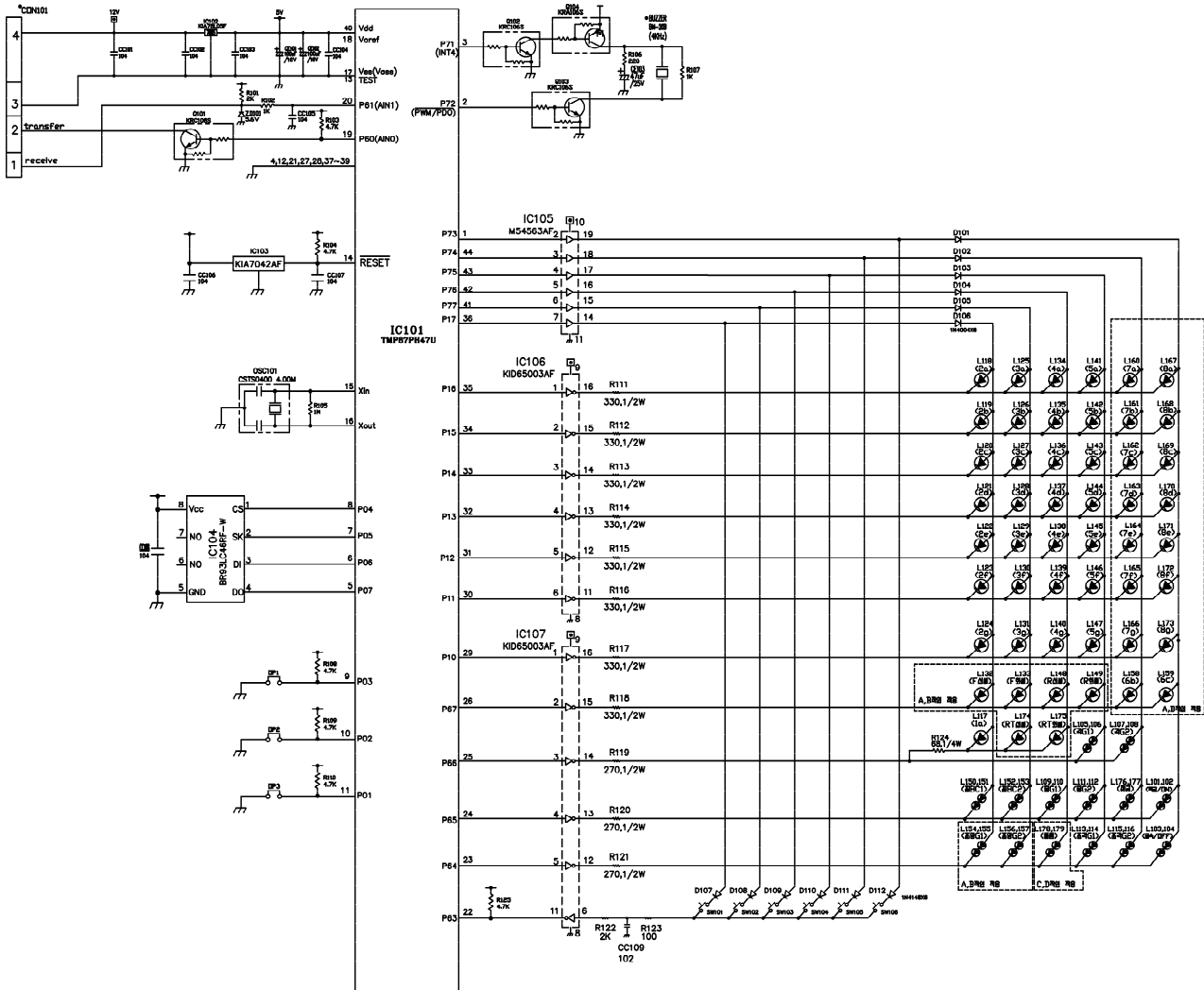

PWB ASSEMBLY DISPLAY

# EXPLANATION FOR MICOM CIRCUIT

3. PWB Circuit Diagram may vary according to model.

LRSC269\*\*\*\*

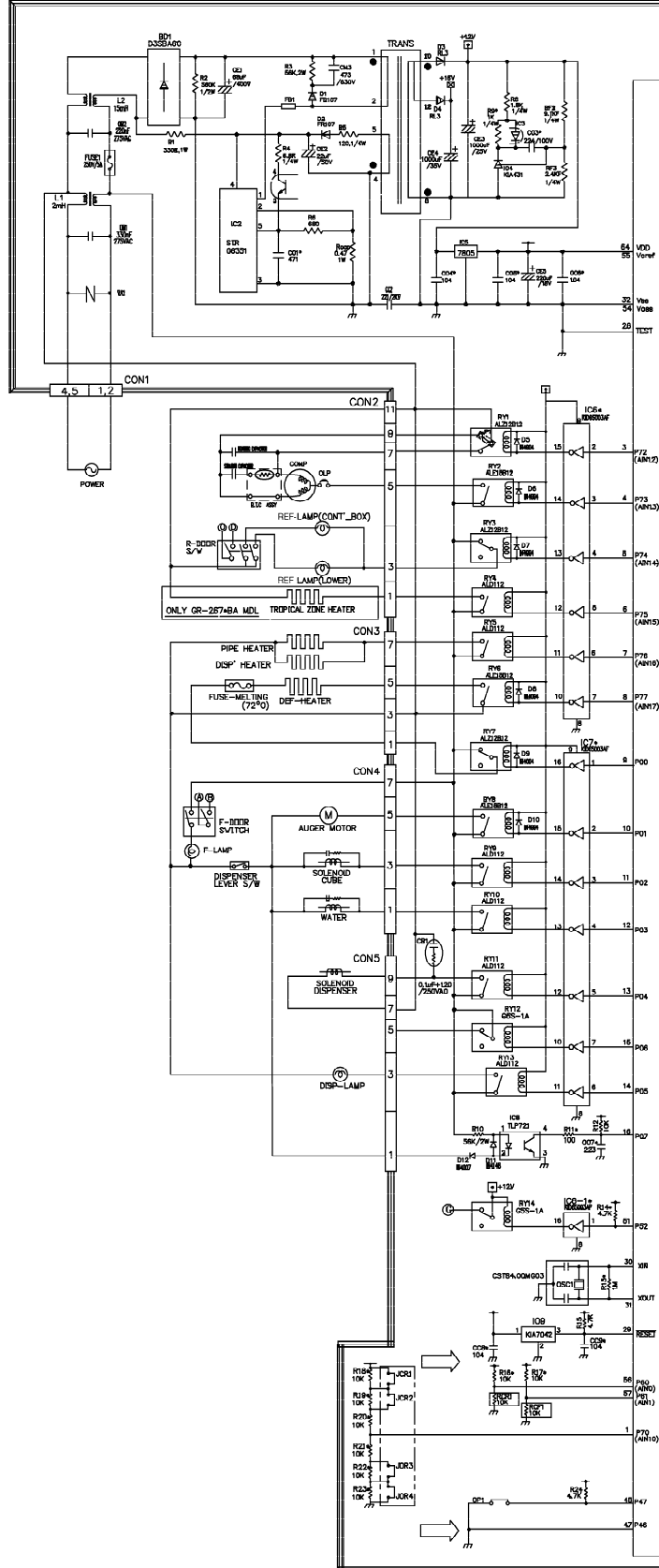

# EXPLANATION FOR MICOM CIRCUIT

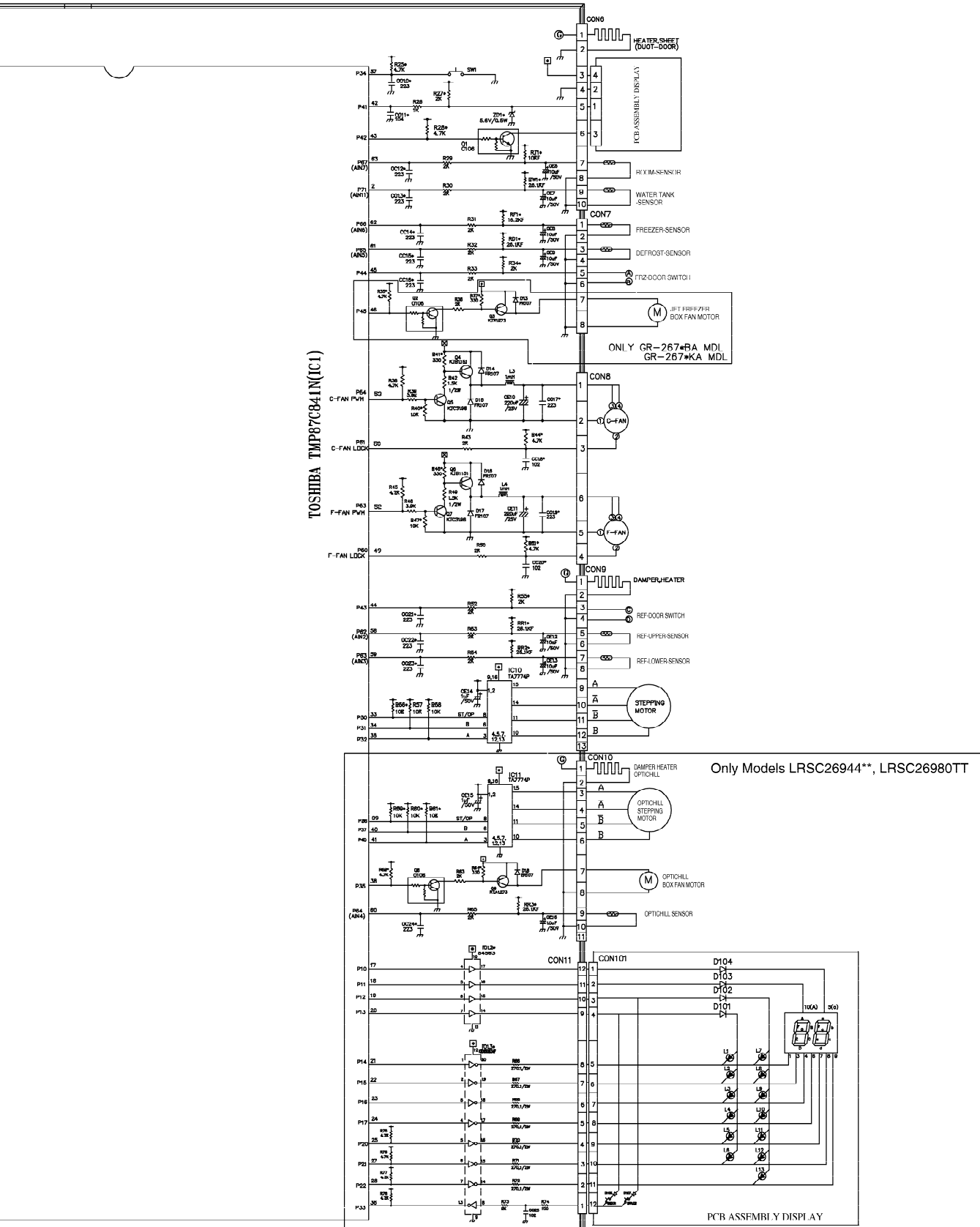

# OPERATION PRINCIPLE AND REPAIR METHOD OF ICEMAKER

## 1. Operation Principle

### 1-1. Operation Principle of Icemaker

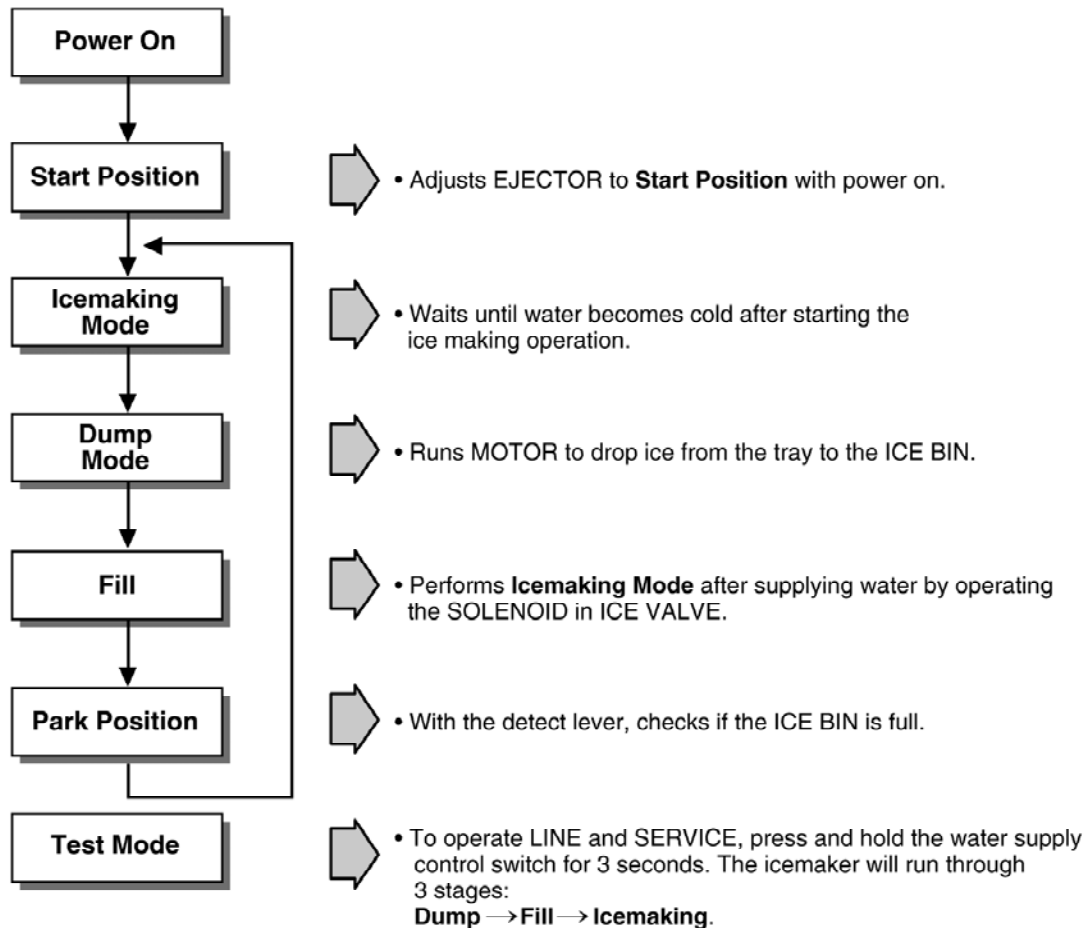

1. Turning the Icemaker stop switch off (O) stops the icemaking function.
2. Setting the Icemaker switch to OFF and then turning it back on will reset the icemaker control.

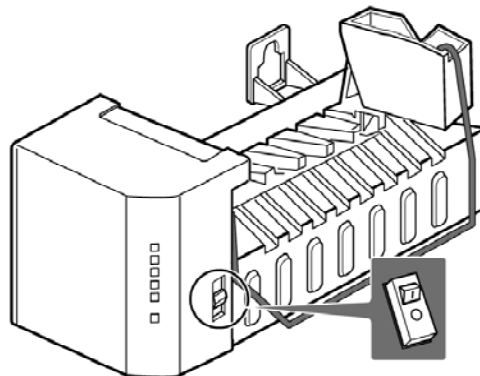



# OPERATION PRINCIPLE AND REPAIR METHOD OF ICEMAKER

## 2. Control Method

### 2-1. Start Position

1. After POWER OFF or Power Outage, check the EJECTOR's position with MICOM initialization to restart.
2. How to check if it is in place:
  - Check **HIGH/LOW** signals from HALL SENSOR in MICOM PIN.
3. Control Method to check if it is in place:
  - (1) EJECTOR is in place,
    - It is an initialized control, so the mode can be changed to ice making control.
  - (2) EJECTOR isn't in place:
    - A. If EJECTOR is back in place within 2 minutes with the motor on, it is being initialized. If not, go to Step B.
    - B. If EJECTOR is back in place within 18 minutes with the heater on (to control Heater on its OFF condition), it is being initialized. If not, it is not functioning. Repeat Step B with Heater and Motor off.

### 2-2. Icemaking Mode

1. Icemaking control refers to the freezing of supplied water in the ice trays. Complete Icemaking operations by measuring the temperature of the Tray with Icemaking SENSOR.
2. Icemaking starts after completing fulfilled ice control and initial control.
3. The Icemaking function is completed when the sensor reaches 19°F(-7°C), 60 to 240 minutes after starting.
4. If the temperature sensor is defective, the Icemaking function will be completed in 4 hours.

### 2-3. Harvest with Dump Mode

1. Harvest with Dump control refers to the operation of dropping cubes into the ice bin from the tray when Icemaking has completed.
2. Harvest with Dump control mode:
  - (1) Operates Heater for 30 seconds; then operate MOTOR.
  - (2) After performing Step 1 (to control the Heater on its off condition), Ice-Removal control will be back in place within 18 minutes. (Hall SENSOR sign = OV). Ice removal is then complete. Then change the mode to the water supply control. If this control phase fails to start, it is not functioning. Put the Heater and Motor in the off position. Restart every 2 hours. (Refer to fig.1)

**NOTE :** If the motor malfunctions and starts before the detect lever rises, MICOM regards the Ice-Removing phase as completed. Water then starts flowing. To prevent this, MICOM doesn't switch to water-supply mode, but restarts the ice-removing mode. If this happens 3 times, the motor is malfunctioning and you should stop the loads (Heater, Motor). Then restart the Ice-Removing mode every 2 hours. (See Step 2 above.)

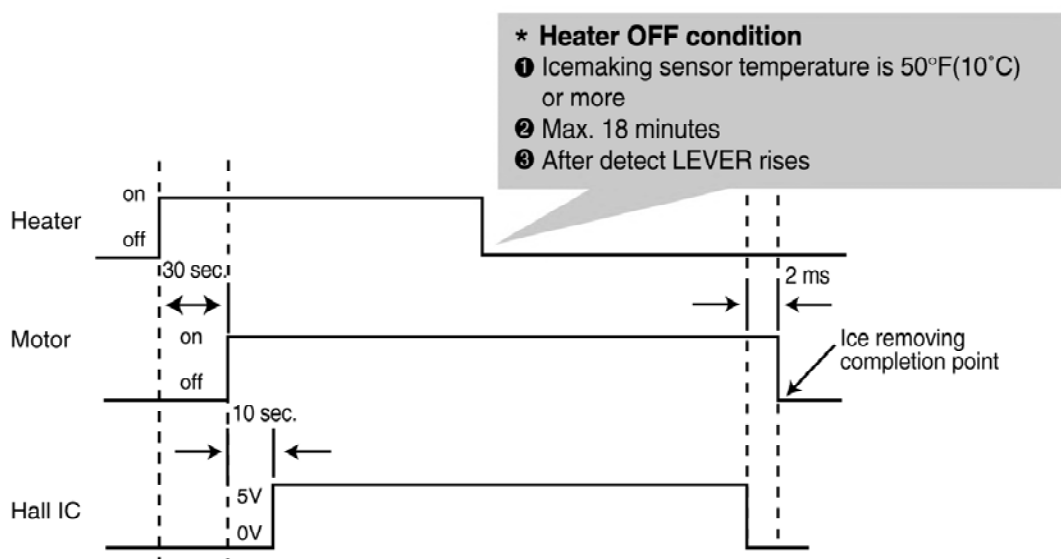





# OPERATION PRINCIPLE AND REPAIR METHOD OF ICEMAKER

## 2-4. Fill / Park Position

1. When Ice-Removing control (Normal Ice-Removing control, Ice-Removing control for test) has completed, and the EJECTOR is in place, this control operates the ICE SOLENOID by time check in the compressor enclosure of the refrigerator. Then it supplies water to the ice making tray.
2. The water supply level is adjustable to 5 levels by pressing the water supply control switch. The selected level will determine the fill time.

**Water supply amount TABLE**





STAGE	TIME TO SUPPLY	INDICATIONS	REMARKS
1	4 sec.		The water amount will vary depending on the water control Switch setting as well as the water pressure of the connected water line.
2	4.5 sec.		
3	5 sec.		
4	5.5 sec.		
5	6 sec.		

# OPERATION PRINCIPLE AND REPAIR METHOD OF ICEMAKER

## 2-5. Function TEST



1. This is a compulsory operation for TEST, SVC, cleaning, etc. It is operated by pressing the water supply control KEY for 3 seconds.
2. It operates in the Icemaking mode, but not in the Ice-Removing mode or water supply process. (If there is an ERROR, it can only be checked in the TEST mode.)
3. If the water supply control KEY is pressed for 3 seconds in the Icemaking mode (no matter what condition the Ice-Making tray is in) the Ice-Removing operation starts immediately. Water is not yet frozen, so water is poured instead of ice. If the control doesn't operate normally in the TEST mode, check and repair as needed.
4. After water is supplied, the normal CYCLE is followed: **Icemaking** → **Dump** → **Fill** → **Park Position**.
5. When Stage 5 is completed in the TEST mode, minimize MICOM in 5 seconds, the time needed to supply water resets to the previous status in the TEST mode.

### Diagnosis TABLE

STAGE	ITEMS	INDICATOR	REMARKS
1	HEATER		Five seconds after heater starts, heater will go off if temperature recorded by sensor is 10°C or lever is in up position.
2	MOTOR		Five seconds after heater starts, you can confirm that motor is moving.
3	HALL IC (detection of position) I		You can confirm Hall IC detection of position.
4	VALVE (Detection of ICE-FULL)		Two seconds after detection of initial position, you can confirm that valve is on.
5	HALL IC (Detection of ICE-FULL) II		You can check whether hall is sensing Full ice condition. (If there is a ICE-FULL error, the fifth LED is not on.)
6	reset	Mark previous status on TEST mode	5 seconds after the last step is completed, the icemaker resets itself to its initial state.

## 3. Defect diagnosis function

### 3-1. ERROR CODES shown on Ice Maker water supply control panel

NO	DIVISION	INDICATOR	CONTENTS	REMARKS
1	Normal	Mark time to supply	None	Display switch operates properly
2	Icemaking Sensor malfunction		Cut or short-circuited wire	Make sure that the wire on each sensor is connected.
3	Icemaker Kit malfunction		When ejector blades doesn't reach park position in 18 minutes after Dump Mode starts.	Defects of HALL IC/MOTOR/ HEATER/RELAY/ STALLED EJECTOR.

ERROR indicators in table can be checked only in TEST mode.

# CIRCUIT

## CIRCUIT DIAGRAM

LRSC26944\*\*, LRSC26980TT

- N : NEUTRAL

### PWB ASSEMBLY, MAIN

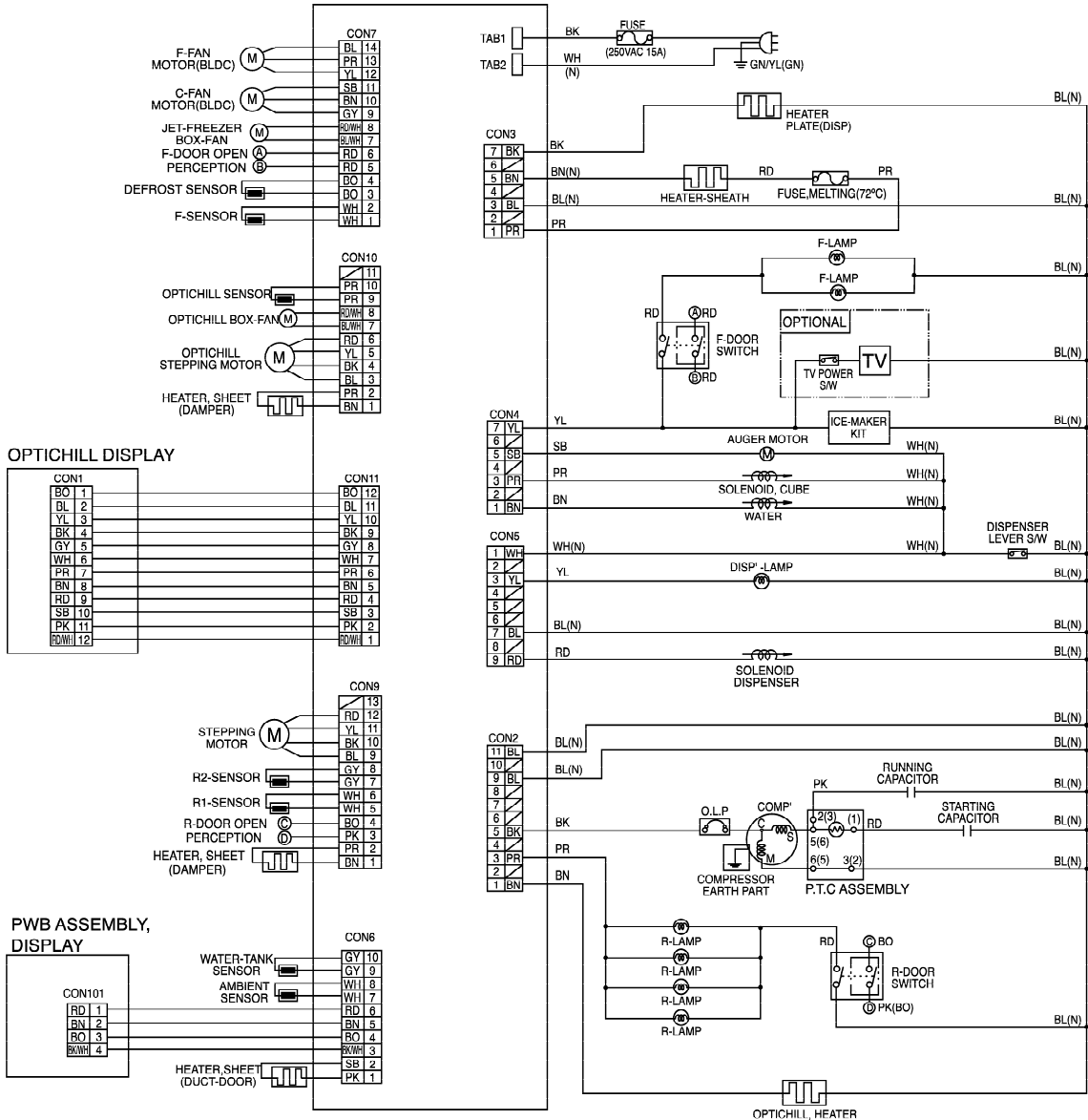

3854JD1092B

BK : BLACK	BN : BROWN	BO : BRIGHT ORANGE	GY : GRAY	RD : RED
YL : YELLOW	GN : GREEN	PR : PURPLE	WH : WHITE	WH/BK : WHITE/BLACK
SB : SKY BLUE	PK : PINK	GN/YN : GREEN/YELLOW	BL/WH : BLUE/WHITE	RD/WH : RED/WHITE

# CIRCUIT

## CIRCUIT DIAGRAM

LRSC26930\*\*

- N : NEUTRAL

### PWB ASSEMBLY, MAIN

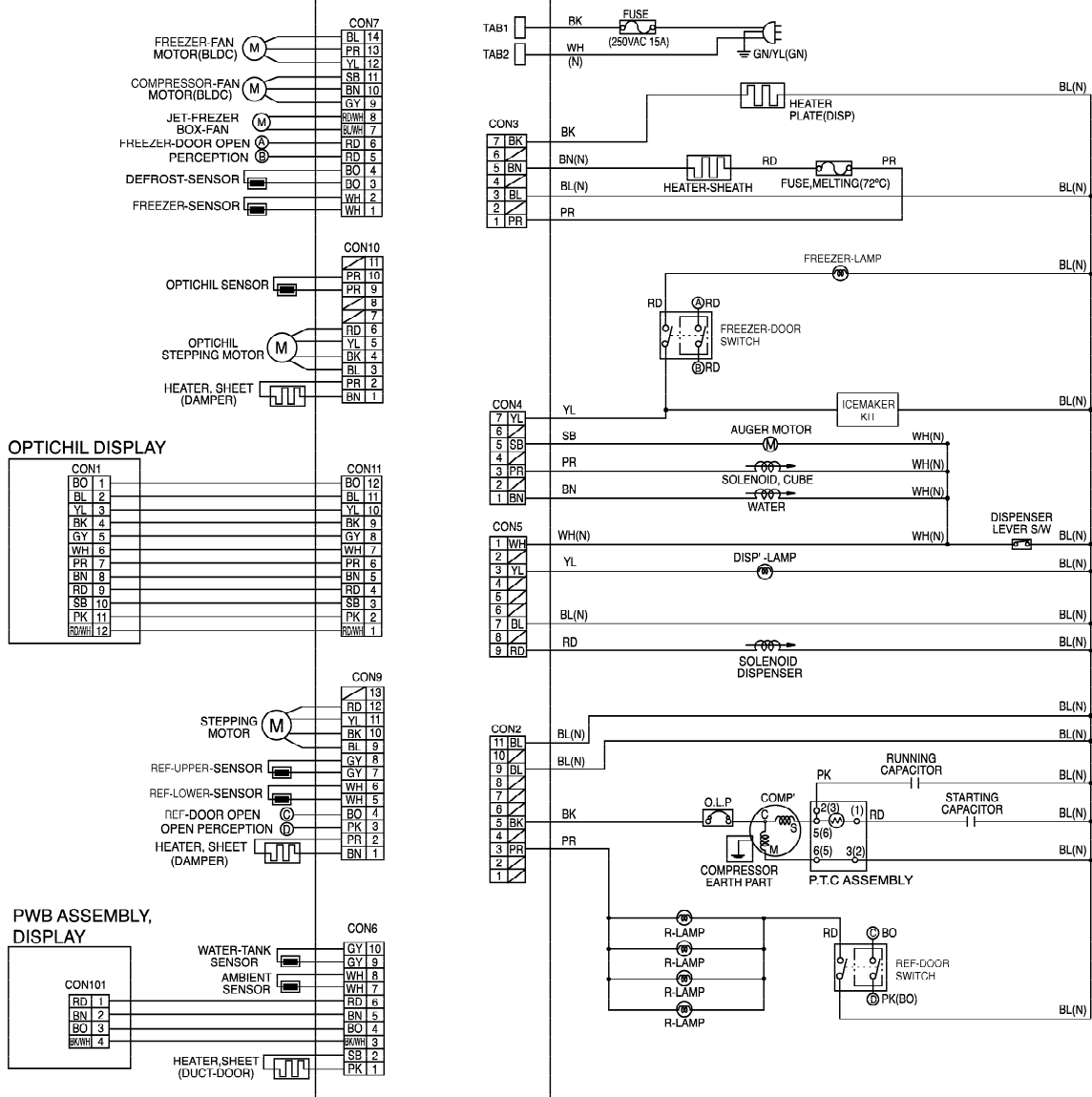

3854JD1092C

BK : BLACK      BN : BROWN      BO : BRIGHT ORANGE      GY : GRAY      RD : RED  
 YL : YELLOW      GN : GREEN      PR : PURPLE      BL/WH : BLUE/WHITE      WH/BK : WHITE/BLACK  
 SB : SKY BLUE      PK : PINK      GN/YN : GREEN/YELLOW      RD/WH : RED/WHITE

# CIRCUIT

## CIRCUIT DIAGRAM

LRSC26920\*\*, LRSC26922\*\*

- N : NEUTRAL

### PWB ASSEMBLY, MAIN

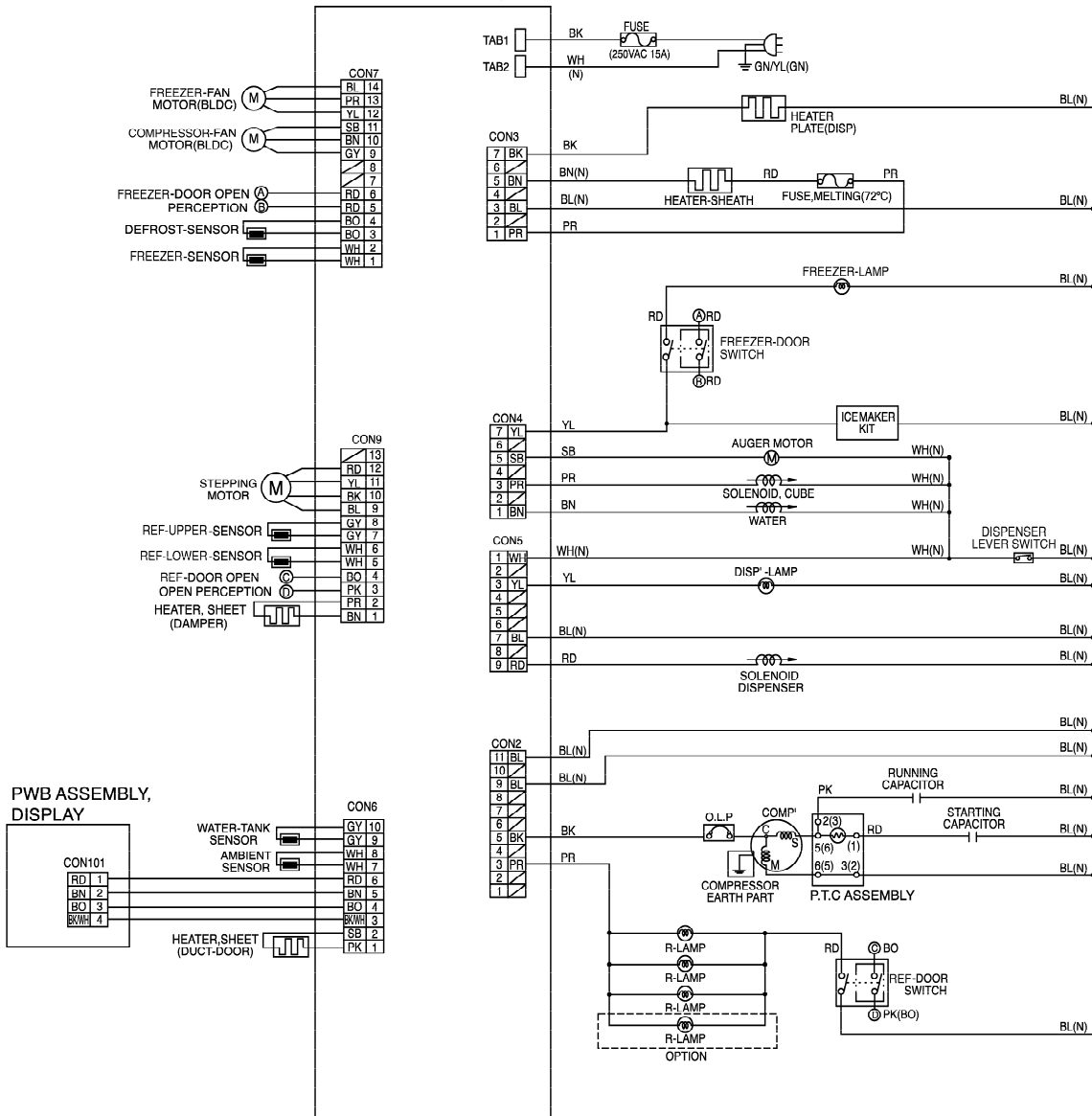

3854JD1092D

BK : BLACK	BN : BROWN	BO : BRIGHT ORANGE	GY : GRAY	RD : RED
YL : YELLOW	GN : GREEN	PR : PURPLE	WH : WHITE	WH/BK : WHITE/BLACK
SB : SKY BLUE	PK : PINK	GN/YN : GREEN/YELLOW	BL/WH : BLUE/WHITE	RD/WH : RED/WHITE

# TROUBLE DIAGNOSIS

## Troubleshooting

PROBLEM	CAUSE/CHECK POINTS	REMARKS
<p>1. Faulty start</p>	<p>1) No power at outlet.</p> <p>2) No power on cord.</p> <ul style="list-style-type: none"> <li>- Bad connection between adapter and outlet. (faulty adapter)               <ul style="list-style-type: none"> <li>- The Inner diameter of adapter.</li> <li>- The distance between holes.</li> <li>- The distance between terminals.</li> <li>- The thickness of terminal.</li> </ul> </li> <li>- Bad connection between plug and adapter (faulty plug).               <ul style="list-style-type: none"> <li>- The distance between pins.</li> <li>- Pin outer diameter.</li> </ul> </li> </ul> <p>3) Shorted start circuit.</p> <ul style="list-style-type: none"> <li>- No power on power cord.               <ul style="list-style-type: none"> <li>- Disconnected copper wire.                   <ul style="list-style-type: none"> <li>- Power cord is disconnected.</li> <li>- Faulty soldering.</li> </ul> </li> <li>- Internal electrical short.</li> <li>- Faulty terminal contact.                   <ul style="list-style-type: none"> <li>- Loose contact.</li> <li>- Large distance between male terminal.</li> <li>- Thin female terminal.</li> <li>- Terminal disconnected.</li> <li>- Bad sleeve assembly.</li> </ul> </li> <li>- Disconnected.                   <ul style="list-style-type: none"> <li>- Weak connection.</li> <li>- Short inserted cord length.</li> <li>- Worn out tool blade.</li> </ul> </li> </ul> </li> <li>- OLP is off.               <ul style="list-style-type: none"> <li>- Capacity of OLP is small.</li> <li>- Characteristics of OLP is bad.</li> <li>- Bad connection.</li> <li>- Power is disconnected.                   <ul style="list-style-type: none"> <li>- Inner Ni-Cr wire blows out.</li> <li>- Bad internal connection.</li> <li>- Faulty terminal caulking (Cu wire is cut).</li> <li>- Bad soldering.</li> </ul> </li> </ul> </li> <li>- No electric power on compressor. - Faulty compressor.</li> <li>- Faulty PTC.               <ul style="list-style-type: none"> <li>- Power does not conduct. - Damage.</li> <li>- Bad characteristics. - Initial resistance is big.</li> <li>- Bad connection with compressor.                   <ul style="list-style-type: none"> <li>- Too loose.</li> <li>- Assembly is not possible.</li> </ul> </li> <li>- Bad terminal connection.</li> </ul> </li> </ul> <p>4) During defrost.</p> <ul style="list-style-type: none"> <li>- Start automatic defrost.</li> <li>- Cycle was set at defrost when the refrigerator was produced.</li> </ul>	<p>* Measuring instrument: Multi tester</p> <p>■ Check the voltage. If the voltage is within <math>\pm 85\%</math> of the rated voltage, it is OK.</p> <p>■ Check the terminal movement.</p> <p>■ Check both terminals of power cord. Power conducts:OK. No power conducts:NG</p> <p>■ Check both terminals of OLP If power conducts:OK. If not:NG.</p> <p>■ Check the resistance of both terminals. At normal temperature 6: OK. If disconnected:<math>\infty</math>.</p>

# TROUBLE DIAGNOSIS

PROBLEM	CAUSE/CHECK POINTS	REMARKS
<p>2. No cooling.</p>	<p>2) Refrigeration system is clogged.</p> <ul style="list-style-type: none"> <li>- Moisture clogged.           <ul style="list-style-type: none"> <li>- Residual moisture in the evaporator.               <ul style="list-style-type: none"> <li>- Air Blowing.                   <ul style="list-style-type: none"> <li>- Not performed.</li> <li>- Too short.</li> <li>- Impossible moisture confirmation.</li> <li>- Low air pressure.</li> </ul> </li> <li>- Leave it in the air.                   <ul style="list-style-type: none"> <li>- During rest time.</li> <li>- After work.</li> </ul> </li> <li>- Caps are missed.</li> </ul> </li> <li>- Residual moisture.               <ul style="list-style-type: none"> <li>- Not dried in the compressor.</li> <li>- Elapsed more than 6 months after drying</li> <li>- Caps are missed.</li> <li>- No pressure when it is open.</li> </ul> </li> </ul> </li> <li>- No electric power on thermostat.           <ul style="list-style-type: none"> <li>- Insufficient drier capacity.               <ul style="list-style-type: none"> <li>- Dry drier - Drier temperature.</li> <li>- Leave it in the air.                   <ul style="list-style-type: none"> <li>- Check on package condition.</li> <li>- Good storage after finishing.</li> </ul> </li> </ul> </li> <li>- Residual moisture in pipes.               <ul style="list-style-type: none"> <li>- Caps are missed.                   <ul style="list-style-type: none"> <li>- During transportation.</li> <li>- During work.</li> </ul> </li> <li>- Air blowing.                   <ul style="list-style-type: none"> <li>- Not performed.</li> <li>- Performed.                       <ul style="list-style-type: none"> <li>- Too short time.</li> <li>- Low air pressure.</li> <li>- Less dry air.</li> </ul> </li> </ul> </li> </ul> </li> <li>- Moisture penetration - Leave it in the air. - Moisture penetration into the refrigeration oil.</li> </ul> </li> <li>- Weld joint clogged.           <ul style="list-style-type: none"> <li>- Short pipe insert.</li> <li>- Pipe gaps.               <ul style="list-style-type: none"> <li>- Too large.</li> <li>- Damaged pipes.</li> </ul> </li> <li>- Too much solder.</li> </ul> </li> <li>- Drier clogging.           <ul style="list-style-type: none"> <li>- The capillary tube inserted depth. - Too much.</li> <li>- Capillary tube melts. - Over heat.</li> <li>- Clogged with foreign materials.               <ul style="list-style-type: none"> <li>- Desiccant powder.</li> <li>- Weld oxides.</li> <li>- Drier angle.</li> </ul> </li> <li>- Reduced cross section by cutting. - Squeezed.</li> </ul> </li> <li>- Foreign material clogging.           <ul style="list-style-type: none"> <li>- Compressor cap is disconnected.</li> <li>- Foreign materials are in the pipe.</li> </ul> </li> </ul>	<ul style="list-style-type: none"> <li>■ Heat a clogged evaporator to check it. As soon as the cracking sound starts, the evaporator will begin to freeze.</li> <li>■ The evaporator does not cool from the beginning (no evidence of moisture attached). The evaporator is the same as before even heat is applied.</li> </ul>



# TROUBLE DIAGNOSIS

PROBLEM	CAUSE/CHECK POINTS	REMARKS
<p>3. Refrigeration is weak.</p>	<p>1) Refrigerant Partly leaked. <span style="margin-left: 20px;">┌ Weld joint leak.</span>  <span style="margin-left: 20px;">└ Parts leak.</span></p> <p>2) Poor defrosting capacity.</p> <p style="margin-left: 20px;">┌ Drain path (pipe) clogged. <span style="margin-left: 20px;">┌ Inject adiabatics into drain hose.</span>  <span style="margin-left: 40px;">└ Foreign materials penetration. <span style="margin-left: 20px;">┌ Adiabatics lump input.</span>  <span style="margin-left: 40px;">└ Damage by a screw or clamp.</span>  <span style="margin-left: 40px;">└ Other foreign materials input.</span></span>  <span style="margin-left: 20px;">└ Cap drain is not disconnected.</span></p> <p style="margin-left: 20px;">┌ Defrost heater does not generate heat. <span style="margin-left: 20px;">┌ Parts disconnected. <span style="margin-left: 20px;">┌ Plate heater <span style="margin-left: 20px;">┌ Wire is cut.</span>  <span style="margin-left: 40px;">└ Heating wire.</span>  <span style="margin-left: 40px;">└ Contact point between heating and electric wire.</span>  <span style="margin-left: 40px;">└ Dent by fin evaporator.</span>  <span style="margin-left: 40px;">└ Poor terminal contacts.</span></span>  <span style="margin-left: 20px;">└ Cord heater <span style="margin-left: 20px;">┌ Wire is cut.</span>  <span style="margin-left: 40px;">└ Lead wire.</span>  <span style="margin-left: 40px;">└ Heating wire.</span>  <span style="margin-left: 40px;">└ Contact point between heating and electric wire.</span>  <span style="margin-left: 40px;">└ Heating wire is corroded</span>  <span style="margin-left: 40px;">└ Water penetration.</span>  <span style="margin-left: 40px;">└ Bad terminal connection.</span></span></span></p>	<p>■ Check visually.</p> <p>■ Check terminal Conduction: OK.          No conduction: NG.          If wire is not cut, refer to resistance.          P=Power          V=Voltage          R=Resistance</p> $P = \frac{V^2}{R}$ $R = \frac{V^2}{P}$

# TROUBLE DIAGNOSIS

PROBLEM	CAUSE/CHECK POINTS	REMARKS
<p>3. Refrigeration is weak.</p>	<ul style="list-style-type: none"> <li>- Residual frost.               <ul style="list-style-type: none"> <li>- Weak heat from heater.                   <ul style="list-style-type: none"> <li>- Sheath Heater - rated.</li> <li>- Heater plate                       <ul style="list-style-type: none"> <li>- No contact to drain.</li> <li>- Loosened stopper cord.</li> </ul> </li> <li>- Heater cord-L                       <ul style="list-style-type: none"> <li>- Not touching the evaporator pipe.</li> <li>- Location of assembly (top and middle).</li> </ul> </li> </ul> </li> <li>- Too short defrosting time.                   <ul style="list-style-type: none"> <li>- Defrost Sensor.</li> <li>- Faulty characteristics.</li> <li>- Seat-D (missing, location, thickness).</li> </ul> </li> <li>- Structural fault.                   <ul style="list-style-type: none"> <li>- Gasket gap.</li> <li>- Air inflow through the fan motor.</li> <li>- Bad insulation of case door.</li> </ul> </li> </ul> </li> <li>- No automatic defrosting.</li> <li>- Defrost does not return.</li> </ul> <p>3) Cooling air leak.</p> <ul style="list-style-type: none"> <li>- Bad gasket adhesion               <ul style="list-style-type: none"> <li>- Gap.</li> <li>- Bad attachment.</li> <li>- Contraction.</li> </ul> </li> <li>- Door sag.               <ul style="list-style-type: none"> <li>- Bad adhesion.</li> <li>- Weak binding force at hinge.</li> </ul> </li> </ul> <p>4) No cooling air circulation.</p> <ul style="list-style-type: none"> <li>- Faulty fan motor.               <ul style="list-style-type: none"> <li>- Fan motor.                   <ul style="list-style-type: none"> <li>- Self locked.</li> <li>- Wire is cut.</li> <li>- Bad terminal contact.</li> </ul> </li> <li>- Door switch.                   <ul style="list-style-type: none"> <li>- Faults.                       <ul style="list-style-type: none"> <li>- Contact distance.</li> <li>- Button pressure.</li> <li>- Melted contact.</li> <li>- Contact.</li> </ul> </li> <li>- Refrigerator and freezer switch reversed.</li> <li>- Button is not pressed.                       <ul style="list-style-type: none"> <li>- Poor door attachment.</li> <li>- Door liner (dimension).</li> <li>- Contraction inner liner.</li> <li>- Misalignment.</li> <li>- Bad terminal connection.</li> <li>- Adiabatics liquid leak.</li> </ul> </li> </ul> </li> </ul> </li> </ul>	<p>■ Check the fan motor conduction: OK. No conduction: NG.</p>

# TROUBLE DIAGNOSIS

PROBLEM	CAUSE/CHECK POINTS	REMARKS
<p>3. Refrigeration is weak.</p>	<p>4) No cooling air circulation.</p> <ul style="list-style-type: none"> <li>Faulty fan motor. — Fan is constrained.               <ul style="list-style-type: none"> <li>Fan shroud contact. - Clearance.</li> <li>Damping evaporator contact.</li> <li>Accumulated residual frost.</li> </ul> </li> <li>Small cooling air discharge.               <ul style="list-style-type: none"> <li>Insufficient motor RPM                   <ul style="list-style-type: none"> <li>Fan overload. - Fan misuse.</li> <li>Bad low temperature RPM characteristics.</li> <li>Rated power misuse.</li> <li>Low voltage.</li> </ul> </li> <li>Faulty fan.                   <ul style="list-style-type: none"> <li>Fan misuse.</li> <li>Bad shape.</li> <li>Loose connection. - Not tightly connected.</li> <li>Insert depth.</li> </ul> </li> <li>Shroud. — Bent.</li> <li>Ice and foreign materials on rotating parts.</li> </ul> </li> </ul> <p>5) Compressor capacity.           <ul style="list-style-type: none"> <li>Rating misuse.</li> <li>Small capacity.</li> <li>Low voltage.</li> </ul> </p> <p>6) Refrigerant too much or too little.           <ul style="list-style-type: none"> <li>Malfunction of charging cylinder.</li> <li>Wrong setting of refrigerant.</li> <li>Insufficient compressor. - Faulty compressor.</li> </ul> </p> <p>7) Continuous operation           <ul style="list-style-type: none"> <li>- No contact of temperature controller. - Foreign materials.</li> </ul> </p> <p>8) Damper opens continuously.           <ul style="list-style-type: none"> <li>Foreign materials jammed.               <ul style="list-style-type: none"> <li>Adiabatics liquid dump.</li> <li>The EPS (styrofoam) drip tray has sediment in it.</li> <li>A screw or other foreign material has fallen into the drip tray or damper.</li> </ul> </li> <li>Failed sensor. - Position of sensor.</li> <li>Characteristics of damper.               <ul style="list-style-type: none"> <li>Bad characteristics of its own temperatue.</li> <li>Parts misuse.</li> <li>Charge of temperature - Impact characteristics.</li> </ul> </li> </ul> </p> <p>9) Food storing place. - Near the outlet of cooling air.</p>	<p>■ Check visually after disassembly.</p> <p>■ Check visually after disassembly.</p>

# TROUBLE DIAGNOSIS

PROBLEM	CAUSE/CHECK POINTS	REMARKS
<p>4. Warm refrigerator compartment temperature.</p> <p>5. No automatic operation. (faulty contacts)</p>	<p>1) Clogged cooling path.</p> <ul style="list-style-type: none"> <li>└ Adiabatics liquid leak.</li> <li>└ Foreign materials. — Adiabatics dump liquid.</li> </ul> <p>2) Food storage.</p> <ul style="list-style-type: none"> <li>└ Store hot food.</li> <li>└ Store too much at once.</li> <li>└ Door open.</li> <li>└ Packages block air flow.</li> </ul> <p>1) Faulty temperature sensor in freezer or refrigerator compartment.</p> <ul style="list-style-type: none"> <li>└ Faulty contact.</li> <li>└ Faulty temperature characteristics.</li> </ul> <p>2) Refrigeration load is too much.</p> <ul style="list-style-type: none"> <li>└ Food. <ul style="list-style-type: none"> <li>└ Too much food.</li> <li>└ Hot food.</li> </ul> </li> <li>└ Frequent opening and closing.</li> <li>└ Cool air leak.</li> <li>└ Poor door closing. — Partially open.</li> </ul> <p>3) Poor insulation.</p> <p>4) Bad radiation.</p> <ul style="list-style-type: none"> <li>└ High ambient temperature.</li> <li>└ Space is secluded.</li> </ul> <p>5) Refrigerant leak.</p> <p>6) Inadequate of refrigerant.</p> <p>7) Weak compressor discharging power.</p> <ul style="list-style-type: none"> <li>└ Different rating.</li> <li>└ Small capacity.</li> </ul> <p>8) Fan does not work.</p> <p>9) Button is set at <b>strong</b>.</p>	<p>■ Inspect parts measurements and check visually.</p>
<p>6. Condensation and ice formation.</p>	<p>1) Ice in freezer compartment.</p> <ul style="list-style-type: none"> <li>└ External air inflow. — Bushing installed incorrectly.</li> <li>└ Door opens but not closes. <ul style="list-style-type: none"> <li>└ Weak door closing power.</li> <li>└ Stopper malfunction.</li> <li>└ Door sag.</li> <li>└ Food hinders door closing.</li> </ul> </li> <li>└ Gap around gasket. — Contraction, distortion, loose, door twisted, corner not fully inserted.</li> <li>└ Food vapor. — Storing hot food. — Unsealed food.</li> </ul> <p>2) Condensation in the refrigerator compartment.</p> <ul style="list-style-type: none"> <li>└ Door opens but not closes. <ul style="list-style-type: none"> <li>└ Insufficient closing.</li> <li>└ Door sag.</li> <li>└ Food hinders door closing.</li> </ul> </li> <li>└ Gasket gap.</li> </ul> <p>3) Condensation on liner foam.</p> <ul style="list-style-type: none"> <li>└ Cool air leak and transmitted. <ul style="list-style-type: none"> <li>└ Not fully filled. <ul style="list-style-type: none"> <li>└ Top table part.</li> <li>└ Out plate Ref/Lower part.</li> </ul> </li> <li>└ Flange gap. — Not sealed.</li> <li>└ Gasket gap.</li> </ul> </li> </ul>	

# TROUBLE DIAGNOSIS

PROBLEM	CAUSE/CHECK POINTS	REMARKS
<p>6. Condensation and ice formation.</p>	<p>4) Condensation on door.</p> <ul style="list-style-type: none"> <li>Condensation on the duct door. - Duct door heater is cut.</li> <li>Condensation on the dispense recess.               <ul style="list-style-type: none"> <li>Recess Heater is cut.</li> <li>Duct door is open. / Foreign material clogging.</li> </ul> </li> <li>Condensation on the door surface.               <ul style="list-style-type: none"> <li>Not fully filled.                   <ul style="list-style-type: none"> <li>Surface.                       <ul style="list-style-type: none"> <li>Liquid shortage.</li> </ul> </li> <li>Corner.                       <ul style="list-style-type: none"> <li>Liquid leak.</li> </ul> </li> </ul> </li> <li>Adiabatics liquid contraction.</li> </ul> </li> <li>Condensation on the gasket surface.               <ul style="list-style-type: none"> <li>Bad wing adhesion.                   <ul style="list-style-type: none"> <li>Wing sag(lower part).</li> <li>Door liner shape mismatch.</li> </ul> </li> <li>Comer.                   <ul style="list-style-type: none"> <li>Too much notch.</li> <li>Broken.</li> </ul> </li> <li>Home Bar heater is cut.</li> </ul> </li> </ul> <p>5) Water on the floor.</p> <ul style="list-style-type: none"> <li>Condensation in the refrigerator compartment.</li> <li>Defrosted water overflows. — Clogged discharging hose.</li> <li>Discharging hose — Evaporation tray located at wrong place. location.</li> <li>Tray drip.               <ul style="list-style-type: none"> <li>Damaged.</li> <li>Breaks, holes.</li> <li>Small Capacity.</li> </ul> </li> <li>Position of drain.</li> </ul>	
<p>7. Sounds</p>	<p>1) Compressor compartment operating sounds.</p> <ul style="list-style-type: none"> <li>Compressor sound inserted.               <ul style="list-style-type: none"> <li>Sound from machine itself.</li> <li>Sound from vibration.                   <ul style="list-style-type: none"> <li>Restrainer.</li> <li>Bushing seat.                       <ul style="list-style-type: none"> <li>Too hard.</li> <li>Distorted.</li> <li>Aged.</li> <li>Burnt.</li> </ul> </li> <li>Stopper. — Bad Stopper assembly.                       <ul style="list-style-type: none"> <li>Not fit (inner diameter of stopper).</li> <li>Tilted.</li> <li>Not</li> </ul> </li> </ul> </li> <li>Compressor base not connected.</li> <li>Bad welding compressor stand(fallen).</li> <li>Foreign materials in the compressor compartment.</li> </ul> </li> <li>OLP sound. — Chattering sound.</li> <li>Capacitor noise. — Insulation paper vibration.</li> <li>Pipe sound.               <ul style="list-style-type: none"> <li>Pipe contacts each other. — Narrow interval.</li> <li>No vibration damper.                   <ul style="list-style-type: none"> <li>Damping Bushing-Q.</li> <li>Damping Bushing-S.</li> </ul> </li> <li>Capillary tube unattached.</li> </ul> </li> </ul>	

# TROUBLE DIAGNOSIS

PROBLEM	CAUSE/CHECK POINTS	REMARKS
7. Sounds	<p>1) Compressor compartment operating sounds.</p> <ul style="list-style-type: none"> <li>Transformer sound. <ul style="list-style-type: none"> <li>Its own fault. — Core gap.</li> <li>Bad connection. — Correct screw connection.</li> </ul> </li> <li>Drip tray vibration sound. <ul style="list-style-type: none"> <li>Bad assembly.</li> <li>Distortion.</li> <li>Foreign materials inside.</li> </ul> </li> <li>Back cover machine sound. <ul style="list-style-type: none"> <li>Bad connection.</li> <li>Partly damaged.</li> </ul> </li> <li>Condenser drain sound. <ul style="list-style-type: none"> <li>Not connected.</li> <li>Bad pipe caulking.</li> </ul> </li> </ul> <p>2) Freezer compartment sounds.</p> <ul style="list-style-type: none"> <li>Fan motor sound. <ul style="list-style-type: none"> <li>Normal operating sound.</li> <li>Vibration sound. <ul style="list-style-type: none"> <li>Aged rubber seat.</li> <li>Bad torque for assembling motor bracket.</li> </ul> </li> </ul> </li> <li>Sounds from fan contact. <ul style="list-style-type: none"> <li>Fan guide contact.</li> <li>Shroud burr contact.</li> <li>Damping evaporator contact.</li> <li>Residual frost contact. <ul style="list-style-type: none"> <li>Damaged heater cord.</li> <li>Narrow evaporator interval.</li> </ul> </li> </ul> </li> <li>Unbalanced fan sounds. <ul style="list-style-type: none"> <li>Unbalanced <ul style="list-style-type: none"> <li>Surface machining conditions.</li> <li>Fan distortion.</li> <li>Misshappen.</li> <li>Burr.</li> </ul> </li> <li>Ice on the fan. — Air intake (opposite to motor bushing assembly.)</li> </ul> </li> <li>Motor shaft contact sounds. <ul style="list-style-type: none"> <li>Supporter distorted.</li> <li>Tilted during motor assembly.</li> </ul> </li> <li>Resonance.</li> <li>Evaporator noise. <ul style="list-style-type: none"> <li>Evaporator pipe contact. — No damping evaporator.</li> <li>Sound from refrigerant. — Stainless steel pipe shape in accumulator.</li> <li>Sound from fin evaporator and pipe during expansion and contraction.</li> </ul> </li> </ul> <p>3) Bowls and bottles make contact on top shelf.</p> <p>4) Refrigerator roof contact.</p> <p>5) Refrigerator side contact.</p> <p>6) Insufficient lubricants on door hinge.</p>	

# TROUBLE DIAGNOSIS

PROBLEM	CAUSE/CHECK POINTS	REMARKS
<p>8. Faulty lamp (freezer and refrigerator compartment).</p>	<p>1) Lamp problem. — Filament blows out. — Glass is broken.</p> <p>2) Bad lamp assembly. — Not inserted. — Loosened by vibration.</p> <p>3) Bad lamp socket.</p> <ul style="list-style-type: none"> <li>— Disconnection. — Bad soldering.</li> <li>— Bad rivet contact.</li> <li>— Short. — Water penetration. — Low water level in tray.</li> <li>— Bad elasticity of contact.</li> <li>— Bad contact (corrosion).</li> </ul> <p>4) Door switch. — Defective.</p> <ul style="list-style-type: none"> <li>— Refrigerator and freezer switches are reversed.</li> <li>— Travel distance.</li> <li>— Bad connection.</li> <li>— Bad terminal contact.</li> <li>— Adiabatics liquid leak..</li> </ul>	
<p>9. Faulty internal voltage (short).</p>	<p>1) Lead wire is damaged.</p> <ul style="list-style-type: none"> <li>— Wire damage when assembling PTC Cover.</li> <li>— Outlet burr in the bottom plate.</li> <li>— Pressed by cord heater. lead wire, evaporator pipe.</li> </ul> <p>2) Exposed terminal.</p> <ul style="list-style-type: none"> <li>— Compressor Compartment terminal. - Touching other components.</li> <li>— Freezer compartment terminal. - Touching evaporator pipe.</li> </ul> <p>3) Faulty parts.</p> <ul style="list-style-type: none"> <li>— Transformer. — Coil contacts cover.</li> <li>— Welded terminal parts contact cover.</li> <li>— Compressor. — Bad coil insulation.</li> <li>— Plate heater.</li> <li>— Melting fuse. — Sealing is broken. — Moisture penetration.</li> <li>— Cord heater. — Pipe damaged. — Moisture penetration.</li> <li>— Bad sealing.</li> <li>— Sheath heater.</li> </ul>	<p>■ Connect conduction and non-conduction parts and check with tester. Conduction: NG. Resistance∞: OK.</p>

# TROUBLE DIAGNOSIS

PROBLEM	CAUSE/CHECK POINTS	REMARKS
<p>10. Structure, appearance, and others.</p>	<p>1) Door foam.</p> <ul style="list-style-type: none"> <li>Sag.               <ul style="list-style-type: none"> <li>Hinge loose                   <ul style="list-style-type: none"> <li>Bolt is loosened during transportation.</li> <li>Not tightly fastened.</li> <li>Screw worn out .</li> </ul> </li> <li>Weak gasket adhesion.                   <ul style="list-style-type: none"> <li>Adhesion surface.</li> </ul> </li> <li>Fixed tape.                   <ul style="list-style-type: none"> <li>Not well fixed.</li> </ul> </li> </ul> </li> <li>Noise during operation.               <ul style="list-style-type: none"> <li>Hinge interference.                   <ul style="list-style-type: none"> <li>Bigger door foam.</li> <li>Hinge-Pin tilted-Poor flatness.</li> <li>No washer.</li> <li>No grease.</li> </ul> </li> </ul> </li> <li>Malfunction.               <ul style="list-style-type: none"> <li>Not closed Refrigerator compartment is opened when freezer compartment is closed (faulty stopper).                   <ul style="list-style-type: none"> <li>Interference between door liner and inner liner.                       <ul style="list-style-type: none"> <li>Stopper worn out.</li> <li>Bad freezer compartment door assembly.</li> <li>No stopper.</li> </ul> </li> </ul> </li> </ul> </li> </ul> <p>2) Odor.</p> <ul style="list-style-type: none"> <li>Temperature of refrigerator compartment.               <ul style="list-style-type: none"> <li>High.                   <ul style="list-style-type: none"> <li>Faulty damper control.</li> <li>Button is set at <b>weak</b>.</li> <li>Door is open (interference by food).</li> </ul> </li> </ul> </li> <li>Deodorizer.               <ul style="list-style-type: none"> <li>No deodorizer.</li> <li>Poor capacity.</li> </ul> </li> <li>Food Storage.               <ul style="list-style-type: none"> <li>Seal condition.</li> <li>Storage of fragrant foods.</li> <li>Long term storage.</li> </ul> </li> <li>Others.               <ul style="list-style-type: none"> <li>Odors from cleaners or items which should not be stored in a refrigerator.</li> </ul> </li> </ul>	



# TROUBLE DIAGNOSIS

## 11. Power

Problems	Causes	Checks	Measures	Remarks
No power on outlet.	<ul style="list-style-type: none"> <li>- Power cord cut.</li> <li>- Faulty connector insertion.</li> <li>- Faulty connection between plug and adapter.</li> </ul>	<ul style="list-style-type: none"> <li>- Check the voltage with a tester.</li> <li>- Check visually.</li> <li>- Check visually.</li> </ul>	<ul style="list-style-type: none"> <li>- Replace the components.</li> <li>- Reconnect the connecting parts.</li> <li>- Reconnect the connecting parts.</li> </ul>	
Fuse blows out.	<ul style="list-style-type: none"> <li>- Short circuit by wrong connection.</li> <li>- Low voltage products are connected to high voltage.</li> <li>- Short circuit by insects.</li> <li>- Electricity leakage.</li> <li>- High voltage.</li> <li>- Short circuit of components (tracking due to moisture and dust penetration).</li> </ul>	<ul style="list-style-type: none"> <li>- Check the fuse with tester or visually.</li> <li>- Check the input voltage with a tester. (between power cord and products).</li> <li>- Check the resistance of power cord with tester (if it is <math>0\Omega</math>, it is shorted).</li> </ul>	<ul style="list-style-type: none"> <li>- Find and remove the cause of problem (ex. short, high voltage, low voltage).</li> <li>- Replace with rated fuse.</li> </ul>	<ul style="list-style-type: none"> <li>- Replace with rated fuse after confirming its specification.</li> <li>■ If fuse blows out frequently, confirm the cause and prevent.</li> </ul>

## 12. Compressor

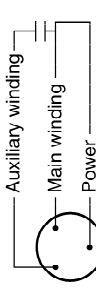
Problems	Causes	Checks	Measures	Remarks
Compressor does not operate.	<ul style="list-style-type: none"> <li>- Faulty PTC.</li> <li>- Compressor is frozen.</li> </ul>	<ul style="list-style-type: none"> <li>- Check the resistance. Value: <math>\infty</math> is defective.</li> </ul>	<ul style="list-style-type: none"> <li>- If resistance is infinite, replace it with new one.</li> <li>- If it is not infinite, it is normal.</li> <li>- Check other parts.</li> </ul>	
	<ul style="list-style-type: none"> <li>- Compressor is frozen.</li> </ul>	<ul style="list-style-type: none"> <li>- If compressor assembly parts are normal (capacitor, PTC, OLP), apply power directly to the compressor to force operation.</li> </ul>  <p>OLP It starts as soon as it is contacted.</p>	<ul style="list-style-type: none"> <li>- During forced operation:</li> <li>- Operates: Check other parts.</li> <li>- Not operate: Replace the frozen compressor with new one, weld, evacuate, and recharge refrigerant.</li> </ul>	<ul style="list-style-type: none"> <li>• Refer to weld repair procedures.</li> </ul>

# TROUBLE DIAGNOSIS

## 13. Temperature

Problems	Causes	Checks	Measures	Remarks
High temperature in the freezer compartment.	Poor cool air circulation due to faulty fan motor.	<ul style="list-style-type: none"> <li>- Lock — Check resistance with a tester.</li> <li>0Ω: short.</li> <li>∞Ω: cut.</li> <li>- Rotate rotor manually and check rotation.</li> <li>- Wire is cut.</li> <li>- Bad terminal contact: Check terminal visually.</li> <li>- Fan constraint: – Fan shroud contact: Confirm visually.</li> <li>– Fan icing: Confirm visually.</li> </ul>	<ul style="list-style-type: none"> <li>- Replace fan motor.</li> <li>- Reconnect and reinsert.</li> <li>- Maintain clearance and remove ice (Repair and/or replace shroud if fan is constrained by shroud deformation).</li> </ul>	
	Faulty fan motor due to faulty door switch operation.	<ul style="list-style-type: none"> <li>- Iced button (faulty) operation: Press button to check</li> <li>- Faulty button pressure and contact: Press button to check operation.</li> <li>- Door cannot press door switch button: Check visually.</li> </ul>	<ul style="list-style-type: none"> <li>- Confirm icing causes and repair.</li> <li>- Replace door switch.</li> <li>- Door sag: fix door.</li> <li>- Door liner bent: replace door or attach sheets.</li> </ul>	
	Bad radiation conditions in compressor compartment.	<ul style="list-style-type: none"> <li>- Check the clearance between the refrigerator and wall (50 mm in minimum).</li> <li>- Check dust on the grill in compressor compartment.</li> <li>- Check dust on the condenser coils.</li> </ul>	<ul style="list-style-type: none"> <li>- Keep clearance between refrigerator and walls (minimum 50mm).</li> <li>- Remove dust and contaminants from grill for easy heat radiation.</li> <li>- Remove the dust with vacuum cleaner from the coils condenser while the refrigerator is off.</li> </ul>	<ul style="list-style-type: none"> <li>- The fan may be broken if cleaning performs while the refrigerator is on.</li> </ul>

# TROUBLE DIAGNOSIS

## 14. Cooling

Problems	Causes	Checks	Measures	Remarks
High temperature in the freezer compartment.	Refrigerant leak.	<p><u>Check sequence</u></p> <ol style="list-style-type: none"> <li>1. Check the welded parts of the drier inlet and outlet and drier auxiliary in the compressor compartment (high pressure side).</li> <li>2. Check the end of compressor sealing pipe (low pressure side).</li> <li>3. Check silver soldered parts. (Cu + Fe / Fe + Fe).</li> <li>4. Check bending area of wire condenser pipe in compressor compartment (cracks can happen during bending).</li> <li>5. Check other parts (compressor compartment and evaporators in freezer compartment).</li> </ol>	Weld the leaking part, recharge the refrigerant.	Drier must be replaced.
	Shortage of refrigerant.	<p>Check frost formation on the surface of evaporator in the freezer compartment.</p> <ul style="list-style-type: none"> <li>- If the frost forms evenly on the surface, it is OK.</li> <li>- If it does not, it is not good.</li> </ul>	<ul style="list-style-type: none"> <li>- Find out the leaking area, repair, evacuate, and recharge the refrigerant.</li> <li>- No leaking, remove the remaining refrigerant, and recharge new refrigerant.</li> </ul>	Drier must be replaced.

# TROUBLE DIAGNOSIS

Problems	Causes	Checks	Measures	Remarks
High temperature in the freezer compartment.	Cycle pipe is clogged.	<p>Check sequence.</p> <ol style="list-style-type: none"> <li>1. Check temperature of condenser manually. If it is warm, OK. If it is not, compressor discharging joints might be clogged.</li> <li>2. Manually check whether hot line pipe is warm. If it is warm, OK. If it is not, condenser outlet weld joints might be clogged.</li> </ol>	<ul style="list-style-type: none"> <li>- Heat up compressor discharging weld joints with torch, disconnect the pipes, and check the clogging. Remove the causes of clogging, weld, evacuate, and recharge the refrigerant.</li> <li>- If it's warm, OK. If it's not, condenser discharging line weld joints might be clogged. Disconnect with torch, remove the causes, evacuate, and recharge seal refrigerant.</li> </ul>	Drier must be replaced.
	Leak at loop pipe weld joint (discharge) in compressor.	<p>Check sequence.</p> <ol style="list-style-type: none"> <li>1. Manually check whether condenser is warm, it is not warm and the frost forms partly on the evaporator in the freezer compartment.</li> </ol>	<ul style="list-style-type: none"> <li>Replace the compressor, weld, evacuate, and recharge refrigerant.</li> </ul>	Drier must be replaced.
	Faulty cooling fan in the compressor compartment.	<p>Check sequence.</p> <ol style="list-style-type: none"> <li>1. Check cooling fan operation.</li> <li>2. Check that cooling fan is disconnected from the motor.</li> </ol>	<ul style="list-style-type: none"> <li>- Replace if motor does not operate.</li> <li>- If fan is disconnected, check fan damage and reassemble it. <ul style="list-style-type: none"> <li>■ Refer to fan motor disassembly and assembly sequence.</li> </ul> </li> </ul>	

# TROUBLE DIAGNOSIS

## 15. Defrosting failure

Problems	Causes	Checks	Measures	Remarks
No defrosting.	<p>Heater does not generate heat as the heating wire is cut or the circuit is shorted.</p> <p>1) Heating wire is damaged when inserting into the evaporator.</p> <p>2) Lead wire of heater is cut.</p> <p>3) Heating wire at lead wire contacts is cut.</p> <p>Suction tube and discharge orifice:</p> <p>1. Impurities.</p> <p>2. Ice.</p>	<p>1. Check the resistance of heater. 0Ω: Short. ∞Ω: Cut. Tens to thousands Ω: OK.</p> <p>2. Check the resistance between housing terminal and heater surface. 0Ω: Short. ∞Ω: Cut. Tens to thousands Ω: Short.</p> <p>1. Confirm foreign materials. In case of ice, insert the copper line through the hole to check.</p> <p>2. Put hot water into the drain (check drains outside).</p>	<p>Heating wire is short and wire is cut.</p> <ul style="list-style-type: none"> <li>Parts replacement: Refer to parts explanations.</li> </ul>	<p>Seal the lead wire with insulation tape and heat shrink tube if the cut lead wire is accessible to repair.</p>
Gap between Suction duct and Heater plate (Ice in the gap).			<p>1) Push out impurities by inserting copper wire. (Turn off more than 3 hours and pour in hot water if frost is severe.)</p> <p>2) Put in hot water to melt down frost.</p> <p>3) Check the water outlet.</p> <p>4) Push the heater plate to suction duct manually and assemble the disconnected parts.</p>	
Wrong heater rating (or wrong assembly).		<p>1. Confirm in the Suction duct.</p>	<p>1) Turn off the power, confirm impurities and ice in the gap, and supply hot water until the ice in the gap melts down.</p> <p>2) Push the Heater plate to drain bottom with hand and assemble the disconnected parts.</p>	
		<p>1. Check heater label.</p> <p>2. Confirm the capacity after substituting the resistance value into the formula.</p> $P = \frac{V^2}{R}$ <p>(V: Rated voltage of user country) (R: Resistance of tester[Ω])</p> <p>Compare P and level capacity. Tolerance: ±7%</p>	<p>Faults: replace.</p> <p>- How to replace : Refer to main parts.</p>	

# TROUBLE DIAGNOSIS

Problems	Causes	Checks	Measures	Remarks
No defrosting	<p>Melting fuse blows.</p> <p>1) Lead wire is cut.</p> <p>2) Bad soldering.</p> <p>Ice in the Suction duct.</p> <p>1) Icing by foreign materials in the duct.</p> <p>2) Icing by cool air inflow through the gap of heater plate.</p> <p>3) Icing by the gap of heater plate.</p>	<p>- Check melting fuse with tester. - If 0Ω: OK. If ∞Ω: wire is cut.</p> <p>1. Check the inner duct with mirror.</p> <p>2. Check by inserting soft copper wire into the duct (soft and thin copper not to impair heating wire).</p>	<p>Faulty parts: parts replacement.</p> <p>- Check wire color when measuring resistance with a tester.</p> <p>1) Turn power off.</p> <p>2) Raise the front side (door side), support the front side legs, and let the ice melt naturally. (If power is on, melt the frost by forced defrosting.)</p> <p>3) Reassemble the heater plate.</p>	
	<p>Bad cool air inflow and discharge, and bad defrosting due to faulty contact and insertion (bad connector insertion into housing of heater, melting, fuse, and motor fan).</p>	<p>1. Turn on power, open or close the door, check that motor fan operates (if it operates, motor fan is OK).</p> <p>2. Disconnect parts in the refrigerator compartment, check the connection around the housing visually, defrost, and confirm heat generation on the heater. Do not put hands on the sheath heater.</p> <p>3. Check the parts which have faults described in 1 &amp; 2 (mechanical model: disconnect thermostat from the assembly).</p>	<p>1) Check the faulty connector of housing and reassemble wrongly assembled parts.</p> <p>2) If the parts are damaged, remove the parts and replace it with a new one.</p>	

# TROUBLE DIAGNOSIS

## 16. Icing

Problems	Causes	Checks	Measures	Remarks
Icing in the refrigerator compartment. - Damper icing. - Pipe icing. - Discharging pipe icing.	1) Bad circulation of cool air. - Clogged intake port in the refrigerator compartment. - Sealing is not good. - Too much food is stored and clogs the discharge port. - Bad defrosting.	- Check the food is stored properly (check discharge and intake port are clogged). - Check icing on the surface of baffle and cool air path (pipe) after disassembling the container box. - Check icing at intake ports of freezer and refrigerator compartment.	- Be acquainted with how to use. - Sealing on connecting parts. - Check the damper and replace it if it has defects. - Check defrost. (After forced defrosting, check ice in the evaporator and pipes.)	- Check the defrost related parts if problem is caused by faulty defrosting.
	2) Faulty door or refrigerator compartment. - Faulty gasket. - Faulty assembly.	- Check gasket attached conditions. - Check door assembly conditions.	- Correct the gasket attachment conditions and replace it. - Door assembly and replacement.	- Replacement should be done when it cannot be repaired.
	3) Overcooling in the refrigerator compartment. - Faulty damper in the refrigerator compartment. - Faulty MICOM (faulty sensor)	- Check refrigerator compartment is overcooled (when button pressed on <b>weak</b> ). - Check parts are faulty.	- Replace faulty parts.	
	4) Bad defrosting - Heater wire is cut. - Defective defrost sensor. - Defrosting cycle.	- Check frost on the evaporator after disassembling shroud and fan grille. - Check ice on intake port of freezer and refrigerator compartment.	- Check parts related to defrosting. - Check defrosting. (Check ice on the evaporator and pipe.)	- Moisture does not freeze on the evaporator but can be sucked into the refrigerator, where it condenses and freezes. This interferes with cold air circulation and sublimation of the ice.
	5) Customers are not familiar with this machine. - Door opens. - High temperature, high moisture, and high load.	- Check food interferes with door closing. - Check ice on the ceilings.	- Be acquainted with how to use.	

# TROUBLE DIAGNOSIS

Problems	Causes	Checks	Measures	Remarks
Ice in the freezer compartment. - Surface of fan grille. - Wall of freezer compartment. - Cool air discharging port. - Basket(rack) area.	1) Bad cooling air circulation. - Intake port is clogged in the freezer compartment. - Discharging port is Clogged. - Too much food is stored. - Bad defrosting.	- Check food storage conditions visually.(Check clogging at intake and discharging port of cooling air.) - Check food occupation ratio in volume (Less than 75%). - Check frost on the evaporator after dissembling shroud and fan grille. - Check icing at intake port of refrigerator compartment.	- Be acquainted with how to use. - Check defrost (Check ice on the evaporator and pipes after forced defrosting).	- Check the parts related to defrosting if the problem is caused by the faulty defrosting.
- Food surface. - Icing in the shute.	2) Bad freezer compartment door - Faulty gasket - Faulty assembly	- Check gasket attachment conditions. - Check door assembly conditions.	- Correct the gasket attachment conditions and replace it. - Door assembly and replacement.	- Replace when it can not be repaired.
	3) Over freezing in the freezer compartment. - Faulty MICOM.	- Refrigerator operates pull down. (Check if it is operated intermittently) - The Temperature of freezer compartment is satisfactory, but over freezing happens in the refrigerator compartment even though the notch is set at <b>weak</b> .	- Replace defective parts.	
	4) Bad defrosting. - Heater wire is cut. - Faulty defrost sensor. - Defrosting cycle	- Check frost on the evaporator after dissembling shroud and grille. - Check ice on the intake port in the refrigerator compartment.	- Check parts related to defrosting. - Check defrosting. Check ice on the evaporator and pipes after forced defrosting.	
	5) User is not familiar with how to use. - Door opens. - High moisture food water is stored.	- Check food holds door open. - Check ice on the ice tray.	- Be acquainted with how to use.	



# TROUBLE DIAGNOSIS

## 17. Sound

Problems	Causes	Checks	Measures	Remarks
Hiss sound	1. Loud sound of compressor operation.	1.1 Check the level of the refrigerator. 1.2 Check the bushing seat conditions (sagging and aging).	1) Maintain horizontal level. 2) Replace bushing and seat if they are sagged and aged. 3) Touch the piping at various place along its route. Install a damper at the point where your touch reduces the noise. 4) Avoid pipe interference. 5) Replace defective fan and fan motor. 6) Adjust fan to be in the center of the fan guide. 7) Leave a clearance between interfering parts and seal gaps in the structures. 8) Reassemble the parts which make sound. 9) Leave a clearance if evaporator pipes and suction pipe touch freezer shroud.	
	2. Pipes resonate sound which is connected to the compressor.	2.1 Check the level of pipes connected to the compressor and their interference. 2.2 Check bushing inserting conditions in pipes. 2.3 Touch pipes with hands or screw -driver (check the change of sound).		
	3. Fan operation sound in the freezer compartment.	3.1 Check fan insertion depth and blade damage. 3.2 Check the interference with structures. 3.3 Check fan motor. 3.4 Check fan motor bushing insertion and aging conditions.		
	4. Fan operation sound in the compressor compartment.	4.1 Same as fan confirmation in the refrigerator. 4.2 Check drip tray leg insertion. 4.3 Check the screw fastening conditions at condenser and drip tray.		

# TROUBLE DIAGNOSIS

Problems	Causes	Checks	Measures	Remarks
Vibration sound. <b>Clack.</b>	<ol style="list-style-type: none"> <li>1. Vibration of shelves and foods in the refrigerator.</li> <li>2. Pipes interference and capillary tube touching in the compressor compartment.</li> <li>3. Compressor stopper vibration.</li> <li>4. Moving wheel vibration.</li> <li>5. Other structure and parts vibration.</li> </ol>	<ol style="list-style-type: none"> <li>1-1. Remove and replace the shelves in the refrigerator</li> <li>1-2. Check light food and container on the shelves.</li> <li>2-1. Touch pipes in the compressor compartment with hands.</li> <li>2-2. Check capillary tube touches cover back.</li> <li>3-1. Check compressor stopper vibration.</li> <li>4-1. Check vibration of front and rear moving wheels.</li> <li>5-1. Touch other structures and parts</li> </ol>	<ol style="list-style-type: none"> <li>1) Reassemble the vibrating parts and insert foam or cushion where vibration is severe.</li> <li>2) Leave a clearance where parts interfere with each other.</li> <li>3) Reduce vibration with bushing and restrainer if it is severe. (especially compressor and pipe).</li> <li>4) Replace compressor stopper if it vibrates severely.</li> </ol>	
Irregular sound. <b>Click.</b>	<ol style="list-style-type: none"> <li>1. It is caused by heat expansion and contraction of evaporator, shelves, and pipes in the refrigerator.</li> </ol>	<ol style="list-style-type: none"> <li>1-1 Check time and place of sound sources.</li> </ol>	<ol style="list-style-type: none"> <li>1) Explain the principles of refrigeration and that the temperature difference between operation and defrosting can make sounds.</li> <li>2) If evaporator pipe contacts with other structures, leave a clearance between them (freezer shroud or inner case).</li> </ol>	

# TROUBLE DIAGNOSIS

Problems	Causes	Checks	Measures	Remarks
Sound <b>Popping</b> (almost the same as animals crying sound).	It happens when refrigerant expands at the end of capillary tube.	<ul style="list-style-type: none"> <li>- Check the sound of refrigerant at the initial installation.</li> <li>- Check the sound when the refrigerator starts operation after forced defrosting.</li> <li>- Check the restrainer attachment conditions on the evaporator and capillary tube weld joints.</li> </ul>	<ul style="list-style-type: none"> <li>- Check the restrainer attached on the evaporator and capillary tube weld joints and attach another restrainer.</li> <li>- If it is continuous and severe, insert capillary tube again (depth 15±3mm)</li> <li>- Fasten the capillary tube to suction pipes or detach in the compressor compartment.</li> <li>- Explain the principles of freezing cycles.</li> </ul>	
Water boiling or flowing sound.	It happens when refrigerant passes orifice in accumulator internal pipes by the pressure difference between condenser and evaporator.	<ul style="list-style-type: none"> <li>- Check the sound when compressor is turned on.</li> <li>- Check the sound when compressor is turned off.</li> </ul>	<ul style="list-style-type: none"> <li>- Explain the principles of freezing cycles and refrigerant flowing phenomenon by internal pressure difference.</li> <li>- If sound is severe, wrap the accumulator with foam and restrainer.</li> </ul>	
Sound of whistle when door closes.	When door closes, the internal pressure of the refrigerator decreases sharply below atmosphere and sucks air into the refrigerator, making the whistle sound.	<ul style="list-style-type: none"> <li>- Check the sound by opening and closing the refrigerator or freezer doors.</li> </ul>	<ul style="list-style-type: none"> <li>- Broaden the cap of discharge hose for defrosting in the compressor compartment.</li> <li>- Seal the gap with sealant between out and inner cases of hinge in door.</li> </ul>	

# TROUBLE DIAGNOSIS

## 18. Odor

Problems	Causes	Checks	Measures	Remarks
Food Odor.	Food (garlic, kimchi, etc)	<ul style="list-style-type: none"> <li>- Check the food is not wrapped.</li> <li>- Check the shelves or inner wall are stained with food juice.</li> <li>- Be sure food is securely covered with plastic wrap.</li> <li>- Check food cleanliness.</li> </ul>	<ul style="list-style-type: none"> <li>- Dry the deodorizer in a sunny place with adequate ventilation.</li> <li>- Store the food in the closed container instead of vinyl wraps.</li> <li>- Clean the refrigerator and set button at <b>strong</b>.</li> </ul>	
Plastic Odor.	Odors of mixed food and plastic odors.	<ul style="list-style-type: none"> <li>- Check wet food is wrapped with plastic bowl and bag.</li> <li>- It happens in the new refrigerator.</li> </ul>	<ul style="list-style-type: none"> <li>- Clean the refrigerator.</li> <li>- Persuade customers not to use plastic bag or wraps with wet food or odorous foods.</li> </ul>	
Odor from the deodorizer.	Odor from the old deodorizer.	<ul style="list-style-type: none"> <li>- Check the deodorizer odors.</li> </ul>	<ul style="list-style-type: none"> <li>- Dry the deodorizer with dryer and then in the shiny and windy place.</li> <li>- Remove and replace the deodorants.</li> </ul>	*Deodorizer : option

# TROUBLE DIAGNOSIS

## 19. Micom

Problems	Symptom	Causes		Checks	Measures	Remarks
Bad PCB electric power.	All display LCD are off.	Bad connection between Main PCB and display circuit.	Bad connector connection from main PCB to display PCB.	Visual check on connector connection.	Reconnect connector.	
		Defective PCB transformer.	PCB transformer winding is cut. PCB transformer temperature fuse is burnt out.	Check resistance of PCB transformer input and output terminals with a tester. (If resistance is infinity, trans winding is cut).	Replace PCB transformer or PCB.	Applicable to model without dispenser.
Abnormal display LCD operation	Defective LCD.	Defective PCB electric circuit parts.	Defective regulator IC (7812, 7805). PCB electric terminal fuse is burnt out. STR Parts are damaged.	Check voltage at input/output terminals. Check fuse in PCB electric terminal with a tester. Check if STR No. 2 and 3 pins are cut when power is off.	Replace regulator. Replace PCB fuse. Replace parts.	Refer to electric circuit in circuit explanation. Applicable to model with dispenser.
		Bad connection between Main PCB and display circuit.	Lead Wire connecting main PCB and display PCB is cut or connector terminal connection is bad.	Check Lead Wire terminals connecting Main PCB and display PCB with a tester.	Reconnect Lead Wire and directly connect defective contact terminal to Lead Wire.	
		Defective LCD.	Defective LCD.	Check if all LCD are on when Main PCB Test switch is pressed (or when both freezer key and power freezer key are pressed at the same time for more than one second.)	Replace display PCB.	Refer to display circuit in circuit explanation.

# TROUBLE DIAGNOSIS

Problems	Symptom	Causes		Checks	Measures	Remarks
Bad cooling.	Freezer temperature is high.	Compressor does not start.	Compressor Lead Wire is cut.	Check compressor Lead Wire with a tester.	Reconnect Lead Wire.	
			Defective compressor driving relay.	Measure voltage at PCB CON2 (3&9) after pressing main PCB test switch once. It is OK if voltage is normal.	Replace relay RY1 and RY2 or PCB.	Refer to load driving circuit in circuit explanation.
	Defective freezer sensor.	Defective Freezer sensor parts.		Check resistance of freezer sensor with a tester.	Replace freezer sensor.	Refer to resistance characteristics table of sensor in circuit. Refer to tables on pages 40, 41, and 43.
		The wrong sensor has been installed.		Confirm the color of sensor in circuits (main PCB sensor housing).	Repair main PCB sensor housing	
	Defective freezer fan motor.	Fan motor lead wire is cut.		Check fan motor lead wire with a tester.	Reconnect lead wire.	
		<ul style="list-style-type: none"> <li>Defective door switch (freezer, refrigerator, home bar).</li> <li>Defective fan motor.</li> <li>Defective fan motor driving relay.</li> </ul>		Measure the voltage between PCB power blue line and fan motor after pressing test switch of Main PCB. If the voltage is normal, it is OK.	<ul style="list-style-type: none"> <li>Replace door switch (freezer, refrigerator, and home bar).</li> <li>Replace fan motor.</li> <li>Replace relay RY5 &amp; RY6 or PCB.</li> </ul>	Refer to load driving circuits in circuit explanation.
	Faulty defrost.			Refer to faulty defrost items in trouble diagnosis functions.		Refer to trouble diagnosis function.

# TROUBLE DIAGNOSIS

Problems	Symptom	Causes		Checks	Measures	Remarks	
Bad cooling	Wrong Refrigerator temperature.	Defective Step Motor Damper.	Check Step Motor damper motor and reed switch and lead wire are cut. Check Step Motor damper part.	Check if Step Motor damper motor and reed switch lead wire are cut with a tester.	Reconnect lead wire.		
			Check Step Motor damper Motor driving relay in PCB.	Refer to Step Motor damper in parts repair guide.	Replace Step Motor damper or refrigerator control box Assembly.		
		Foreign materials in Step Motor damper baffles.	Remove materials in Step Motor damper baffles visually.	Check Step Motor damper baffle visually.	Remove foreign materials.		
			Ice formation on Step Motor damper baffles.	Check if Step Motor damper Heater wire is cut with a tester.	Replace Step Motor damper or refrigerator control Box Assembly.		
		Defective refrigerator sensor parts.	Defective refrigerator sensor parts.	Check the resistance of refrigerator sensor with a tester.	Replace refrigerator sensor.	Refer to sensor resistance characteristic table in circuit explanation.	
			Refrigerator sensor is substituted for other sensor.	Check the sensor color in the circuit. (main PCB sensor housing.)	Repair main PCB sensor housing.		
		Defective refrigerator sensor assembly condition.	Defective refrigerator sensor assembly condition.	Check if refrigerator sensor is not fixed at cover sensor but inner case visually.	Fix again the refrigerator sensor.		

# TROUBLE DIAGNOSIS

Problems	Symptom	Causes	Checks	Measures	Remarks
Bad defrost.	Defrost is not working.	Defrost lead wire is cut.	Check if defrost lead wire is cut with a tester.	Reconnect Lead Wire.	
		Defective defrost driving relay.	Check the voltage of CON2 (1 and 7) with a tester after pressing main PCB test switch twice. If the voltage is normal then it is OK.	Replace relay (RY 7 and RY 3) or PCB.	Refer to load driving conditions check in circuit explanation.
		Defective defrost sensor parts.	Check the resistance of defrost sensor with a tester.	Replace defrost sensor.	Refer to sensor resistance characteristic table of circuit explanation.
Defective buzzer	Buzzer continuously rings or door opening alarm does not work.	Defective connecting lead wire from main PCB to door switch.	Check lead wire related to door switch with a tester.	Repair lead wire.	
		Defective door switch parts.	Refer to door switch in parts repair guide.	Replace door switch.	
Defective display button	Buzzer does not sound and buttons do not operate.	Key input wire is cut or bad connector terminal contact in main PCB and display PCB connecting lead wire.	Check input wire with a tester.	Reconnect lead wire and replace or directly connect bad contact terminal to lead wire.	Refer to display circuit in circuit explanation.
		Key is continuously depressed due to structural interference.	Disassemble frame display and confirm visually.	Adjust or replace interfering structures.	



# TROUBLE DIAGNOSIS

Problems	Symptom	Causes	Checks	Measures	Remarks
Defective display button.	Buzzer does not sound and buttons do not operate.	Trouble mode indication.	Check trouble diagnosis function.	Repair troubles	Refer to mode indication in function explanations.
Door Buzzer	Buzzer continuously rings or door opening alarm does not work.	Defective connecting lead wire from main PCB to door switch.	Check lead wire associated with door switch.	Repair lead wire.	Check model with dispenser.
		Defective freezer compartment door switch parts.	Refer to door switch in parts repair guide.	Replace Freezer compartment door switch.	
Bad water/ice dispenser.	Ice and water are not dispensed.	Defective connecting lead wire from Main PCB to lever switch.	Check Lead Wire associated with lever switch with a tester.	Repair lead wire.	
		Defective lever switch parts	Refer to door switch in parts repair guide.	Replace lever switch.	
		Defective photo coupler IC parts.	Check voltage change at photo coupler output terminals with lever switch pressed. It is OK if voltage change is between 0V - 5V.	Replace photo coupler IC or PCB.	
		Defective relay associated with ice dispense (gearing motor, cube, and dispenser solenoid).	Check relay (RY4, RY5, RY12) with a tester.	Replace defective relay.	
		Defective parts associated with ice dispense (gearing motor, cube, and dispenser solenoid).	Check resistance of parts with a tester.	Replace defective parts.	
		Defective relay associated with water dispense.	Check relay (RY7) with a tester	Replace defective relay.	
	Defective parts associated with water dispenser.	Check resistance of parts with a tester.	Replace defective parts.		

# TROUBLE DIAGNOSIS

## Cooling Cycle Heavy Repair

### 1. The Heavy Repair Standards for Refrigerator with R134a Refrigerant

NO.	Items	Unit	Standards	Purposes	Remarks	
1	Pipe and piping system opening time.	Min.	Pipe:within 1 hour. Comp:within 10 minutes. Drier:within 20 minutes.	To protect Moisture Penetration.	The opening time should be reduced to a half of the standards during rain and rainy seasons (the penetration of water into the pipe is dangerous).	
2	Welding.	Nitrogen Pressure.	Weld under Nitrogen atmosphere (N <sub>2</sub> pressure: 0.1~0.2 kg/cm <sup>2</sup> )	To protect oxide scale formation.	- Refer to repair note in each part. - R134a refrigerant is more susceptible to leaks than R12 and requires more care during welding. - Do not apply force to pipes before and after welding to protect pipe from cracking.	
3	N <sub>2</sub> sealed parts.	Confirm N <sub>2</sub> leak.	Confirm air leaking sounds when removing bushing cap. Sound:usable No sound:not usable	To protect moisture penetration.	- In case of evaporator parts, if it doesn't make noise when removing bushing cap blow dry air or N <sub>2</sub> gas for more than 1 min use the parts.	
4	Refrigeration Cycle.	Evacuation time	Min.	More than 40 minutes.	To remove moisture.	Note:Only applicable to the model equipped with reverse flow protect plate.  Vacuum efficiency can be improved by operating compressor during evacuation.  The bushing pipes for R12 refrigerant shall be melted when they are used for R134a refrigerant causes of leak.
		Vacuum degree	Torr	Below 0.03(ref)		
		Vacuum	EA	High and low Pressure sides are evacuated at the same time for models above 200ℓ		
		Vacuum piping	EA	Use R134a exclusive manifold.	To protect mixing of mineral and ester oils.	
		Pipe coupler	EA	Use R134a exclusive.	To protect R12 Refrigerant mixing.	
		Outlet (Socket) Plug		R134a exclusive. R134a exclusive		
5	Refrigerant weighing.	EA	Use R134a exclusively. Weighing allowance:±5g Note:Winter:-5g Summer:+5g	Do not mix with R12 refrigerant.	- Do not weigh the refrigerant at too hot or too cold an area. (25°C[77°F] is adequate.) - Use copper charging canister Socket:2SV Plug: 2PV R134a Note : Do not burn O-ring (rubber) during welding.	
6	Drier replacement.		-Use R134a exclusively for R134a refrigerator -Replace drier whenever repairing refrigerator cycle piping.	To remove the moisture from pipe.		
7	Leak check.		-Do not use soapy water for check. It may be sucked into the pipe.	Detect refrigerant leak area.	-Check oil leak at refrigerant leak area. Use electronic leak detector if oil leak is not found. -The electronic leak detector is very sensitive to halogen gas in the air. It also can detect R141b in urethane. Please practice, therefore, many times before use.	

# TROUBLE DIAGNOSIS

## 2. Summary Of Heavy Repair

Process	Contents	Tools
<b>Trouble diagnosis</b>		
<b>Remove refrigerant Residuals</b>	- Cut charging pipe ends and discharge refrigerant from drier and compressor.	Filter, side cutters
<b>Parts replacement and welding</b>	- Use R134a oil and refrigerant for compressor and drier - Confirm N <sub>2</sub> sealing and packing conditions before use. Use good one for welding and assembly. - Weld under nitrogen gas atmosphere. (N <sub>2</sub> gas pressure: 0.1-0.2kg/cm <sup>2</sup> ). - Repair in a clean and dry place.	Pipe Cutter, Gas welder, N <sub>2</sub> gas
<b>Vacuum</b>	- Evacuate for more than forty minutes after connecting manifold gauge hose and vacuum pump to high (drier) and low (compressor refrigerant discharging parts) pressure sides. - Evacuation Speed:113 liters/minute.	Vacuum pump R134a exclusively, Manifold gauge.
<b>Refrigerant charging and charging inlet welding</b>	- Weigh and control the allowance of R134a charging canister in a vacuum conditions to be ±5 g with electronic scales and charge through compressor inlet (Charge while compressor operates). - Weld carefully after pinching off the inlet pipe.	R134a exclusive charging canister (mass cylinder), refrigerant R134a manifold gauge, electronic scales, pinch-off plier, gas welding machine
<b>Check refrigerant leak and cooling capacity</b>	- Check leak at weld joints. <ul style="list-style-type: none"> <li>□ Minute leak : Use electronic leak detector</li> <li>□ Big leak : Check visually.</li> </ul> Note:Do not use soapy water for check. - Check cooling capacity ① Check radiator manually to see if warm. ② Check hot line pipe manually to see if warm. ③ Check frost formation on the whole surface of the evaporator.	Electronic Leak Detector, Driver (Ruler).
<b>Compressor compartment and tools arrangement</b>	- Remove flux from the silver weld joints with soft brush or wet rag. Flux may be the cause of corrosion and leaks. - Clean R134a exclusive tools and store them in a clean tool box or in their place.	Copper brush, Rag, Tool box
<b>Transportation and installation</b>	- Installation should be conducted in accordance with the standard installation procedure. Leave space of more than 5 cm (2 inches) from the wall for compressor compartment cooling fan mounted model.	

# TROUBLE DIAGNOSIS

## 3. Precautions During Heavy Repair

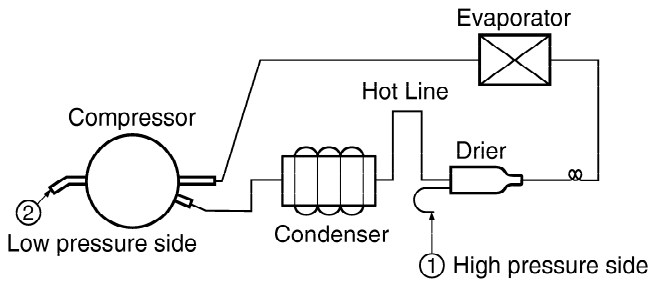
Items	Precautions
1. Use of tools.	1) Use special parts and tools for R134a.
2. Recovery of refrigerant.	<p>1) Continue to recover the refrigerant for more than 5 minutes after turning the refrigerator off.</p> <p>2) Install a piercing type valve on the high pressure line (drier side). Then use the appropriate recovery equipment to recover the refrigerant from the system. When the refrigerant has been recovered, install a piercing type valve on the low pressure side. <b>IT IS IMPORTANT TO OPEN THE SYSTEM IN THIS ORDER TO KEEP THE OIL FROM BEING FORCED OUT.</b></p> <p>The use of piercing type valves will allow future servicing and eliminates the possibility of a defective pinch off.</p>  <p>The diagram illustrates a refrigeration cycle with the following components and labels: Compressor, Low pressure side (marked with a circled 2), Condenser, Hot Line, Drier, High pressure side (marked with a circled 1), and Evaporator. The piping connects these components in a closed loop.</p>
3. Replacement of drier.	1) Be sure to replace drier with R134a only when repairing pipes and injecting refrigerant.
4. Nitrogen blowing welding.	1) Use pressurized nitrogen to prevent oxidation inside the piping. (Nitrogen pressure : 0.1~0.2 kg/cm <sup>2</sup> .)
5. Others.	<p>1) Only nitrogen or R134a should be used when cleaning the inside of piping of the sealed system.</p> <p>2) Check leakage with an electronic leakage tester.</p> <p>3) Be sure to use a pipe cutter when cutting pipes.</p> <p>4) Be careful not the water let intrude into the inside of the cycle.</p>

# TROUBLE DIAGNOSIS

## 4. Practical Work For Heavy Repair

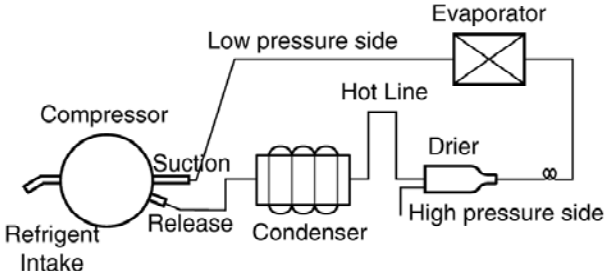
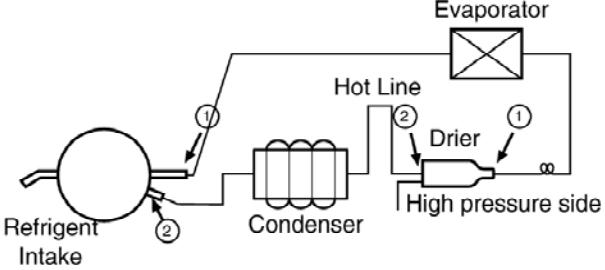
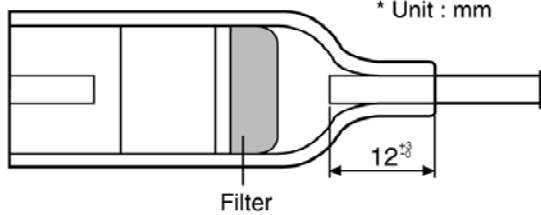
Items	Precautions
<p>1. Removal of residual refrigerant.</p>	<div style="display: flex; justify-content: space-between;"> <div style="width: 60%;">  <p>1) Continue to recover the refrigerant for more than 5 minutes after turning the refrigerator off.</p> <p>2) Install a piercing type valve on the high pressure line (drier side). Then use the appropriate recovery equipment to recover the refrigerant from the system. When the refrigerant has been recovered, install a piercing type valve on the low pressure side. <b>IT IS IMPORTANT TO OPEN THE SYSTEM IN THIS ORDER TO KEEP THE OIL FROM BEING FORCED OUT.</b></p> <p>The use of piercing type valves will allow future servicing and eliminates the possibility of a defective pinch off.</p> </div> <div style="width: 35%;"> <p><b>KEY POINT</b> Observe the sequence for removal of refrigerant. (If not, compressor oil may leak.)</p> </div> </div>
<p>2. Nitrogen blowing welding.</p>	<div style="display: flex; justify-content: space-between;"> <div style="width: 60%;">  <p><b>When replacing a drier:</b> Weld ① and ② parts by blowing nitrogen (0.1~0.2kg/cm<sup>2</sup>) to high pressure side after assembling a drier.</p> <p><b>When replacing a compressor:</b> Weld ① and ② parts by blowing nitrogen to the low pressure side.</p> <p>Note) For other parts, nitrogen blowing is not necessary because it does not produce oxidized scales inside pipe because of its short welding time.</p> </div> <div style="width: 35%;"> <p><b>KEY POINT</b> Welding without nitrogen blowing produces oxidized scales inside a pipe, which affect performance and reliability of a product.</p> </div> </div>
<p>3. Replacement of drier.</p>	<div style="display: flex; justify-content: space-between;"> <div style="width: 60%;">  <p><b>Inserting a capillary tube</b> Measure distance with a ruler and put a mark(12<sup>+3/0</sup>)on the capillary tube. Insert tube to the mark and weld it</p> </div> <div style="width: 35%;"> <p><b>KEY POINT</b> Be sure to check the inserted length of capillary tube when it is inserted. (If inserted too far, the capillary tube will be blocked by the filter.)</p> </div> </div>

# TROUBLE DIAGNOSIS

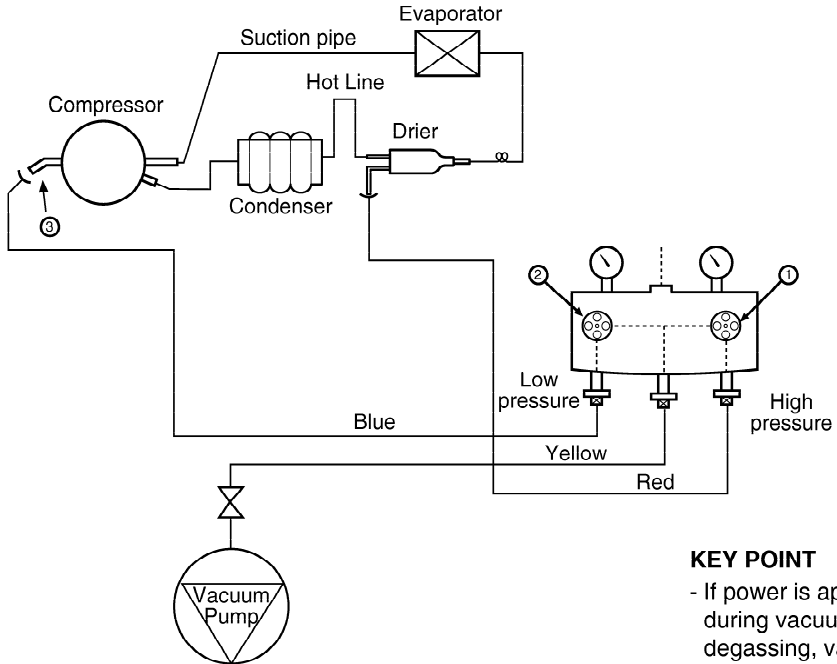
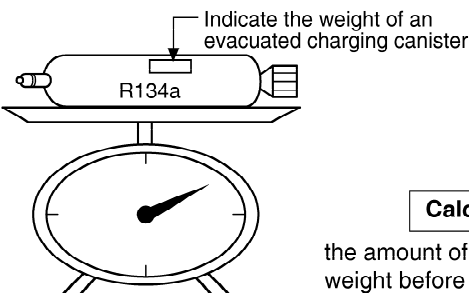
Items	Precautions
<p>4. Vacuum degassing.</p>	<div style="text-align: center;">  </div> <p><b>KEY POINT</b></p> <ul style="list-style-type: none"> <li>- If power is applied during vacuum degassing, vacuum degassing shall be more effective.</li> <li>- Run the compressor while charging the system. It is easier and works better.</li> </ul> <p><b>Pipe Connection</b> Connect the red hose to the high pressure side and the blue hose to the low pressure side.</p> <p><b>Vacuum Sequence</b> Open valves ① and ② and evacuate for 40 minutes. Close valve ①.</p>
<p>5. Refrigerant charging.</p>	<p><b>Charging sequence</b></p> <ol style="list-style-type: none"> <li>1) Check the amount of refrigerant supplied to each model after completing vacuum degassing.</li> <li>2) Evacuate charging canister with a vacuum pump.</li> <li>3) Measure the amount of refrigerant charged. <ul style="list-style-type: none"> <li>- Measure the weight of an evacuated charging canister with an electronic scale.</li> <li>- Charge refrigerant into a charging canister and measure the weight. Calculate the weight of refrigerant charged into the charging canister by subtracting the weight of an evacuated charging canister.</li> </ul> </li> </ol> <div style="text-align: center;">  </div> <p><b>KEY POINT</b></p> <ul style="list-style-type: none"> <li>- Be sure to charge the refrigerant at around 25°C [77°F].</li> <li>- Be sure to keep -5g in the winter and +5g in the summer.</li> </ul> <div style="border: 1px solid black; padding: 5px; width: fit-content; margin: 10px auto;"> <p><b>Calculation of amount of refrigerant charged</b></p> </div> <p>the amount of refrigerant charged = weight after charging - weight before charging (weight of an evacuated cylinder)</p>

# TROUBLE DIAGNOSIS

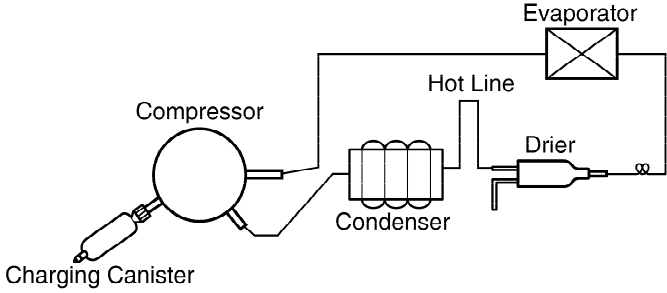
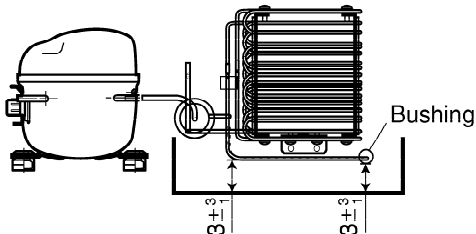
Items	Precautions
	 <p>4) Refrigerant Charging Charge refrigerant while operating a compressor as shown above.</p> <p>5) Pinch the charging pipe with a pinch-off plier after completion of charging.</p> <p>6) Braze the end of a pinched charging pipe with copper brazer and take a gas leakage test on the welded parts.</p>
6. Gas-leakage test	* Test for leaks on the welded or suspicious area with an electronic leakage tester.
7. Pipe arrangement in each cycle	<p>When replacing components, be sure each pipe is replaced in its original position before closing the cover of the mechanical area.</p> 

## 5. Standard Regulations For Heavy Repair

- 1) Observe the safety precautions for gas handling.
- 2) Use JIG (or a wet towel) in order to prevent electric wires from burning during welding. (In order to prevent insulation break and accident.)
- 3) The inner case will melt and the insulation will burn.
- 4) The copper piping will oxidize.
- 5) Do not allow aluminum and copper pipes to touch. (In order to prevent corrosion.)
- 6) Observe that the inserted length of a capillary tube into a drier should be  $12^{+3}$  mm.

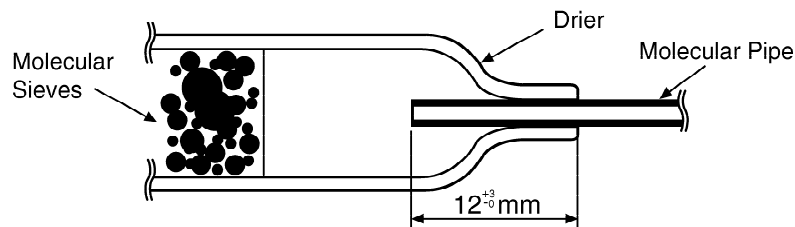

- 7) Make sure that the inner diameter is not distorted while cutting a capillary tube.
- 8) Be sure that the suction pipe and the filling tube should not be substituted each other during welding. (High efficiency pump.)

# TROUBLE DIAGNOSIS

## 6. Brazing Reference Drawings

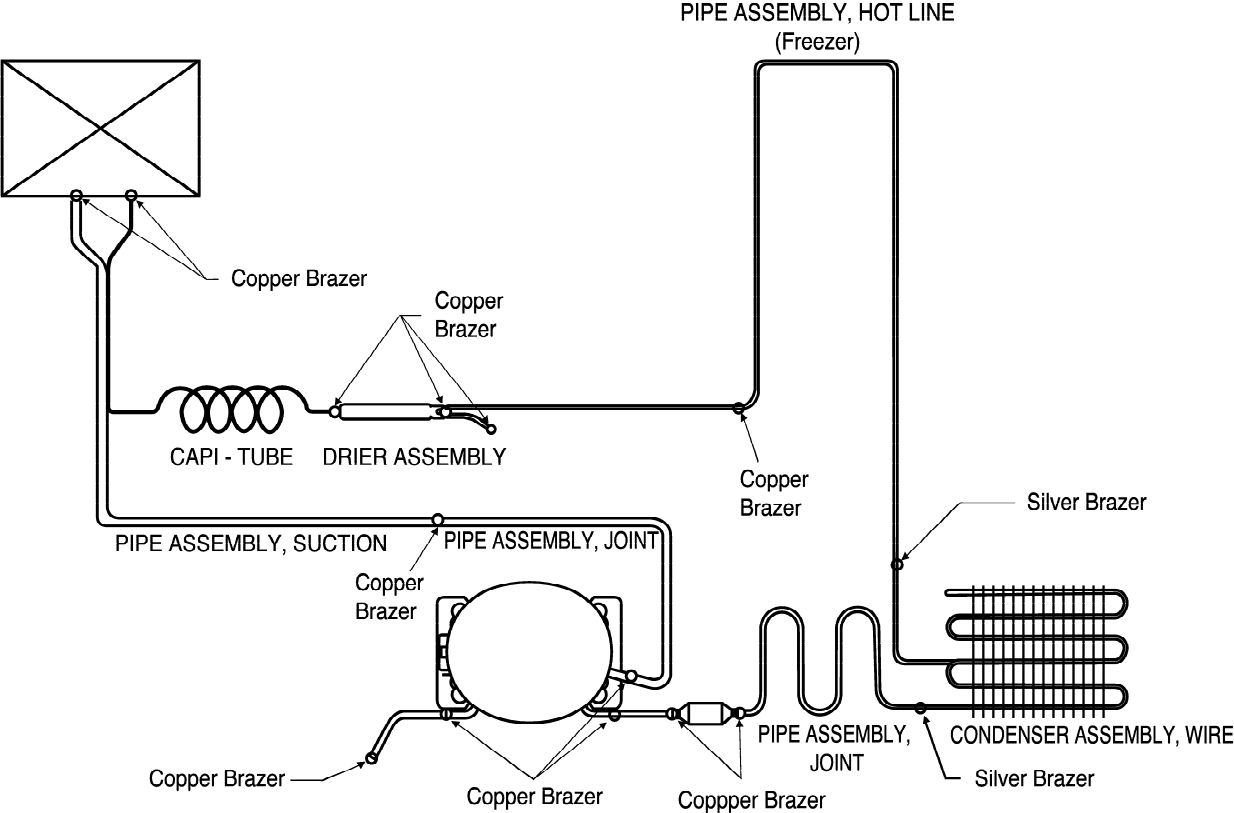



# TROUBLE DIAGNOSIS

## HOW TO DEAL WITH CLAIMS

### 1. Sound

Problems	Checks and Measures
Hiss sounds	<p>■ <b>Explain general principles of sounds.</b></p> <ul style="list-style-type: none"> <li>• All refrigerators make noises when they run. The compressor and fan produce sounds. There is a fan in the freezer compartment which blows cool air to freezer and refrigerator compartments. <b>Hiss</b> sounds are heard when the air passes through the narrow holes into the freezer and refrigerator compartments.</li> </ul> <p>■ <b>Cooling Fan sound in the compressor compartment.</b></p> <ul style="list-style-type: none"> <li>• There is a fan on the back of the refrigerator which cools the compressor compartment. If there is a small space between the refrigerator and the wall, the air circulation sounds may be noticeable.</li> </ul> <p>■ <b>Noise of Compressor.</b></p> <ul style="list-style-type: none"> <li>• This operating sound happens when the compressor compresses the refrigerant. The compressor rotates at 3600 RPM. The sound of compressor large refrigerators make more noise than small ones</li> </ul>
Click sounds	<p>■ <b>Explain the principles of temperature change.</b></p> <ul style="list-style-type: none"> <li>• The sounds happens when pipes and internal evaporator in the refrigerator compartment expand and contract as the temperature changes during the refrigerator operation. This sound also happens during defrosting, twice a day, when the ice on the evaporator melts.</li> </ul>
Clunk sound	<p>■ <b>Explain that it comes from the compressor when the refrigerator starts.</b></p> <ul style="list-style-type: none"> <li>• When the refrigerator operates, the piston and motor in the compressor rotate at 3600 RPM. This sound is caused by the vibration of motor and piston when they start and finish their operation. This phenomenon can be compared with that of cars. When an automobile engine starts, it is loud at first but quiets down quickly. When the engine stops, so does the vibration.</li> </ul>
Vibration sound	<p>■ <b>Check the sound whether it comes from the pipes vibration and friction.</b></p> <ul style="list-style-type: none"> <li>• Insert bushing or leave a space between pipes to avoid the noise.</li> <li>• Fix the fan blade if it is hitting on the shroud</li> <li>• Fix the drip tray if it is loosened.</li> </ul> <p>■ <b>Sound depends on the installation location.</b></p> <ul style="list-style-type: none"> <li>• Sound becomes louder if the refrigerator is installed on a wooden floor or near a wooden wall. Move it to the another location.</li> <li>• If the refrigerator is not leveled properly, a small vibration can make a loud sound. Please adjust the level of the refrigerator.</li> </ul>

# TROUBLE DIAGNOSIS

Problems	Checks and Measures
Sounds of water flowing	<p>■ <b>Explain the flow of refrigerant.</b></p> <ul style="list-style-type: none"> <li>• When the refrigerator stops, the water flowing sound happens. This sound happens when the liquid or vapor refrigerant flows from the evaporator to compressor.</li> </ul>
Click sounds	<p>■ <b>Explain the characteristics of moving parts.</b></p> <ul style="list-style-type: none"> <li>• This noise comes from the MICOM controller's switch on the top of the refrigerator when it is turned on and off.</li> </ul>
<p>Noise of Icemaker operation (applicable to model with Icemaker).</p> <ul style="list-style-type: none"> <li>- Noise produced by ice dropping and hitting ice bin.</li> <li>- Noise from motor sounds <b>Hiss</b>.</li> </ul>	<p>■ <b>Explain the procedure and principles of Icemaker operation.</b></p> <ul style="list-style-type: none"> <li>• Automatic Icemaker repeats the cycle of water supplying → icemaking → ice ejection. When water is supplied, the water supply valve in the machine room makes sounds like <b>Hiss</b> and water flowing also makes sound. When water freezes, clicking sounds are heard. When ice is being ejected, sounds like <b>Hiss</b> produced by a motor to rotate an ice tray and ice dropping and hitting ice bin sounds are also heard.</li> </ul>
Noise when supplying water.	<p>■ <b>Explain the principles of water supplied to dispenser.</b></p> <ul style="list-style-type: none"> <li>• When the water supply button in the dispenser is pressed, the water supply valve in the compressor compartment opens and let the water flow to the water tank in the lower part of the refrigerator compartment. The water is dispensed by this pressure. When this happens, motor sound and water flowing sound are heard.</li> </ul>
Noise when supplying ice.	<p>■ <b>Explain the principles of ice supply and procedure of crushed icemaking in a dispenser.</b></p> <ul style="list-style-type: none"> <li>• When ice cube button is pressed, ice stored in the ice bin is moved by an auger and dispensed. If crushed ice button is pressed, the ice cube is crushed. When this happens, ice crushing and hitting ice bin sounds are heard.</li> </ul>

# TROUBLE DIAGNOSIS

## 2. Measures for Symptoms on Temperature

Problems	Checks and Measures
Refrigeration is weak.	<p>■ <b>Check temperature set in the temperature control knob.</b></p> <ul style="list-style-type: none"> <li>Refrigerator is generally delivered with the button set at <b>normal use</b> (MID). But customer can adjust the temperature set depending on their habit and taste. If you feel the refrigeration is weak, then set the temperature control button at <b>strong</b> position. If you adjust the button in the freezer compartment as well, the refrigeration is stronger than adjusting refrigerator only.</li> </ul>
The food in the chilled drawer is not frozen but defrosted	<p>■ <b>The chilled drawer does not freeze food.</b></p> <ul style="list-style-type: none"> <li>Use chilled drawer for storing fresh meat or fish for short periods. For storing for a long period or freezing food, use a freezer compartment. It is normal that frozen foods thaw above the freezing temperature (in the chilled drawer).</li> </ul>
Refrigerator water is not cool.	<p>■ <b>Check the water storage location.</b></p> <ul style="list-style-type: none"> <li>If water is kept in the door rack, move it to a refrigerator shelf. It will then become cooler.</li> </ul>
Ice cream softens.	<p>■ <b>Explain the characteristics of ice cream.</b></p> <ul style="list-style-type: none"> <li>The freezing point of ice cream is below <math>-15^{\circ}\text{C}</math>[<math>5^{\circ}\text{F}</math>]. Therefore ice cream may melt if it is stored in the door rack.</li> <li>Store ice cream in a cold place or set the temperature control button of a freezer at <b>strong</b> position.</li> </ul>
Refrigeration is too strong.	<p>■ <b>Check the position of temperature control button.</b></p> <ul style="list-style-type: none"> <li>Check if refrigeration is strong in whole area of the refrigerator or partly near the outlet of the cooling air. If it is strong in whole area, set the control button at <b>weak</b>. If it is strong only near the outlet of cool air, keep food (especially damp foods and easily frozen foods) away from the outlet.</li> </ul>
Vegetables are frozen.	<p>■ <b>Check the vegetables storage.</b></p> <ul style="list-style-type: none"> <li>If vegetables are stored in the refrigerator shelf or chilled drawer instead of vegetable drawer, they will be frozen. Set the control button at <b>weak</b> if they are also frozen in the vegetable drawer.</li> </ul>
The food stored at inside of the shelf freezes even the control button is set at <b>MID</b> .	<p>■ <b>Check if food is stored near the outlet of the cooling air.</b></p> <ul style="list-style-type: none"> <li>The temperature at cooling air outlet is always below the freezing point. Do not store food near the outlet of the cooling air as it block the air circulation. Do not block the outlet. If the outlet of the cooling air is blocked, the refrigerator compartment will not be cooled.</li> </ul>

# TROUBLE DIAGNOSIS

## 3. Odor and Frost

Problems	Checks and Measures
Odor in the refrigerator compartment.	<p>■ <b>Explain the basic principles of food odor.</b></p> <ul style="list-style-type: none"> <li>• Each food has its own particular odor. Therefore it is impossible to prevent or avoid food odor completely when food is stored in the completely sealed refrigerator compartment. The deodorizer can absorb some portions of the odor but not completely. The intensity of odor depends on refrigerator conditions and environments.</li> </ul> <p>■ <b>Check the temperature control button and set at strong.</b></p> <ul style="list-style-type: none"> <li>• Clean inside of the refrigerator with detergent and remove moisture. Dry inside the refrigerator by opening the door for about 3 or 4 hours and then set the temperature control button at <b>strong</b>.</li> </ul>
Frost in the freezer compartment	<p>■ <b>Explain the basic principles of frost formation.</b></p> <ul style="list-style-type: none"> <li>• The main causes for frosting:               <ul style="list-style-type: none"> <li>- Door was left open.</li> <li>- Air penetration through the gasket</li> <li>- Too frequent door opening. (parties. etc.)</li> <li>- Hot foods are stored before they are cooled down. The temperature of freezer is -19°C[-2.2°F]. if temperature is set at <b>MID</b>. If hot air comes into the refrigerator, fine frost forms as cold air mixes with hot air. If this happens quite often, much frost forms inside of the refrigerator. If the door is left open in Summer, ice may form inside of the refrigerator.</li> </ul> </li> </ul>
Frost in ice tray.	<p>■ <b>Explain basic principles of frost formation.</b></p> <ul style="list-style-type: none"> <li>• When ice tray with full of water is put into a freezer compartment, the water evaporates. If cool air fan operates, the moisture attached to the jaw (protruded part) of ice mold will freeze and form frost. If warm water was put into the ice mold, the situation will become worse.</li> </ul>

# TROUBLE DIAGNOSIS

## 4. Others

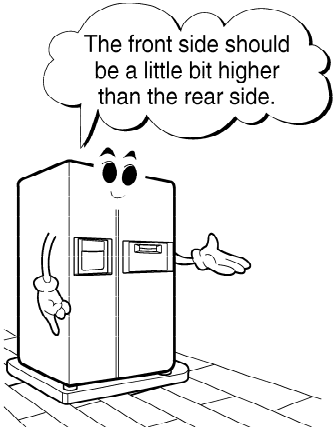
Problems	Checks and Measures
The refrigerator case is hot.	<ul style="list-style-type: none"> <li>■ Explain the principles of radiator.               <ul style="list-style-type: none"> <li>• The radiator pipes are installed in the refrigerator case and partition plate between the refrigerator and the freezer compartment in order to prevent condensation formation. Particularly in summer or after installation of refrigerator, it may feel hot but it is normal. If there is not enough space to dissipate heat, it can be hotter due to lack of heat radiation. Please install a refrigerator in a well-ventilated place and leave the clearance between refrigerator and wall:</li> </ul> </li> </ul>
Small holes in a door liner	<ul style="list-style-type: none"> <li>■ Explain that the hole is for releasing gas.               <ul style="list-style-type: none"> <li>• A small hole in the door liner is for releasing gas during insulation materials lining work. With a releasing hole, forming can be easily done .</li> </ul> </li> </ul>
Electric bills are too much.	<ul style="list-style-type: none"> <li>■ Explain that the hole is to allow the air to escape when vacuum forming plastic parts and pumping foam insulation into cavities.               <p><b>NOTE!</b> Holes and releasing gas appear to be very crude and would not be acceptable in a manual.</p> <p>There are small holes in the plastic liner of some parts of the refrigerator. These holes allow plastic parts to be injection molded and vacuum formed by allowing air bubbles to be expelled. They also allow foam insulation to be pumped into cavities where air bubbles may build up.</p> </li> </ul>
Condensation on the inside wall of the refrigerator compartment and the cover of properly vegetable drawer.	<ul style="list-style-type: none"> <li>■ Explain how to store foods               <ul style="list-style-type: none"> <li>• Condensation forms when refrigerator is installed at damp area, door is frequently opened, and wet foods are not stored in the air tight container or wrapped. Be sure to store wet foods in airtight containers or securely covered in plastic wrap.</li> </ul> </li> </ul>
When is the power connected?	<ul style="list-style-type: none"> <li>■ When should the power be connected ?               <ul style="list-style-type: none"> <li>• You can connect the power immediately after installation. However, if the refrigerator was laid flat before or during installation, you must stand it upright for 6 hours before plugging it in. This allows the refrigerant oils to return to the sump in the compressor. If you operate the refrigerator before the oil has had a chance to settle, you could damage the compressor.</li> </ul> </li> </ul>
<p>Door does not open properly.</p> 	<ul style="list-style-type: none"> <li>■ Refrigerator compartment door does not open properly.               <ul style="list-style-type: none"> <li>• When the door is open, warm open air comes into the compartment and is mixed up with cool air. This mixed air shall be compressed and increase the internal pressure when door is closed. This causes the door stucked closely to the refrigerator in a moment. (If the refrigerator is used for a long time, it will open smoothly.)</li> </ul> </li> <li>■ When the refrigerator compartment door is opened and closed, the freezer compartment door moves up and down.               <ul style="list-style-type: none"> <li>• When the refrigerator compartment door is opened and closed, fresh air comes into the freezer compartment and moves up and down the freezer compartment door.</li> </ul> </li> <li>■ Door opens too easily.               <ul style="list-style-type: none"> <li>• There is a magnet in the gasket so it closes securely without a gap. It can be held open easily if something is in the way and obstructs the door's closing.</li> </ul> </li> <li>■ A door does not close properly.               <ul style="list-style-type: none"> <li>• If the refrigerator is not properly leveled, the doors will not close easily. Adjust the level using the leveling screws under the front of the refrigerator.</li> </ul> </li> </ul>

# HOW TO DISASSEMBLE AND ASSEMBLE

## 1. DOOR

### 1) Remove lower cover and then disconnect water supply tube in the lower part of freezer door.

- Pull the water supply tube ② forward while pressing on the coupling ① as shown in the drawing.

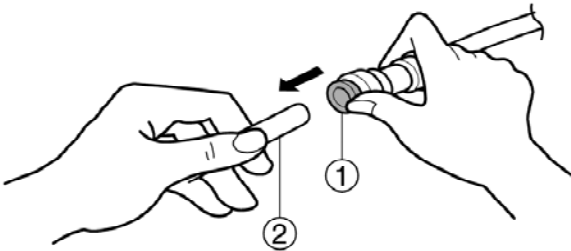

- ⚠ Disconnecting the tube under the door causes about 1.5 liters of water to flow out. Please put up a big container to prevent it.

### 2) Remove a freezer door.

- (1) Loosen hinge cover screw of freezer door and remove cover. Disconnect all connecting lines except grounding cord.

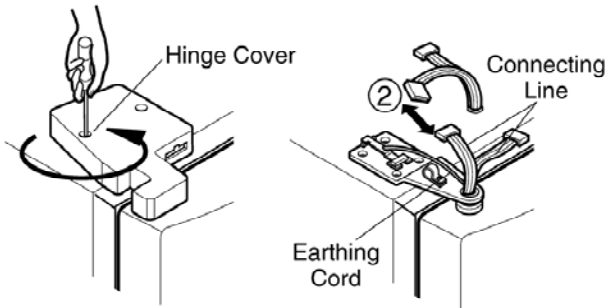

- (2) Turn hinge lever in arrow (A) direction until it is loosened and take it out in arrow (B) direction.

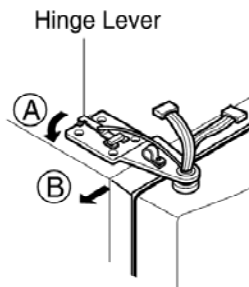

- Note : • When disconnecting refrigerator door, turn hinge lever counterclockwise.

- If the hinge or bracket are bent during assembly, use two extra screws (Tap Tite M6, Left Hinge attaching screw) in the holes of the upper hinge.

- (3) Disconnect upper hinge ① from the hinge supporter ② by grasping the front part of upper hinge and lifting up (Hinge Assembly, U) in arrow direction (A) and pull forward in arrow (B) direction. Be careful because the door may fall, damaging the door, the floor, or injuring you.

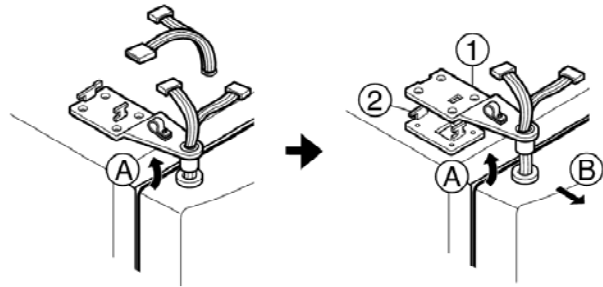

- (4) Lift up the freezer door ① in arrow direction and disconnect the door from the lower hinge ②. Don't pull the door forward.

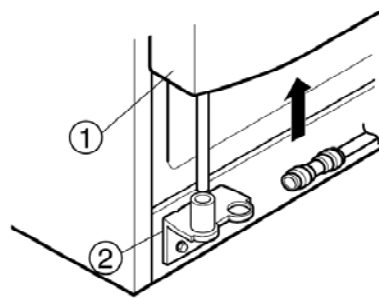

- Note : • Lift up the freezer door until a water supply tube is fully taken out.

- (5) Assembly is the reverse order of disassembly

# HOW TO DISASSEMBLE AND ASSEMBLE

## 2. HANDLE

### 1. Aluminum Handle Model

1) Use a small screwdriver blade in the groove at the side of the Deco Handle to lift and separate the cover. Twist down in the direction of arrow ① and lift the cover in the direction of arrow ②.

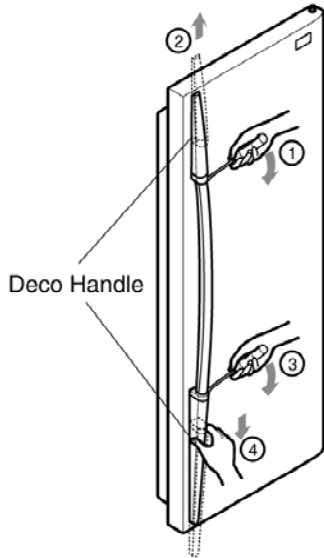

2) Use a small screwdriver blade in the groove at the side of the Deco Handle to lift and separate the cover. Twist down in the direction of arrow ③ and lift the cover in the direction of arrow ④.

3) Push the handle piece ③ in the direction of the arrow and disconnect it.

4) Turn screw in arrow direction with a philips driver and disconnect.

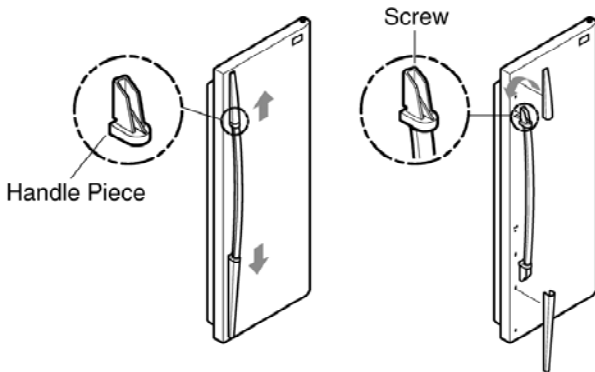

### 2. Plastic handle Model

1) Use a small screwdriver blade in the groove at the side of the Deco Handle to push it down slightly and separate the cover. Push down in the direction of arrow ① and push the cover down in the direction of arrow ②.



2) Turn screw in arrow ① direction with a cross driver and lift up a little bit in arrow ② and pull it up in arrow ③.

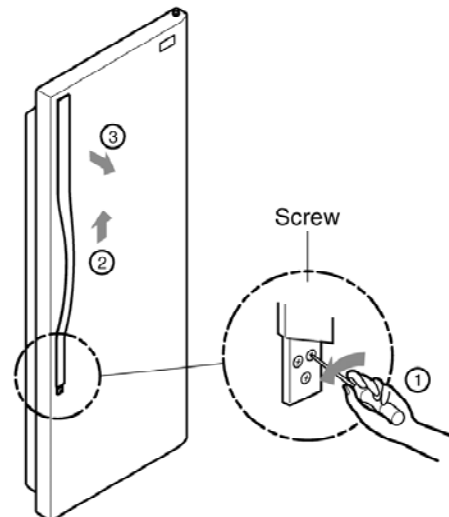

# HOW TO DISASSEMBLE AND ASSEMBLE

---

## 3. Fan Shroud Grille

- 1) Loosen two screws after disconnecting a cap screw of a grille fan (U) with a screwdriver blade.
- 2) Disassembly of a grille fan (U) : Pull forward after opening hook at → part with a screwdriver blade.
- 3) Disconnect housing A of a grille fan (L) from the main body.
- 4) Disassembly of a grille fan (L) : Hold upper part of a grille fan (L) and pull forward carefully.
- 5) Loosen two screws.
- 6) Disassembly of shroud. F (U) : Disconnect housing of B after removing two rail guides with a screwdriver blade.
- 7) Disassembly of shroud. F (U) : Hold upper part and pull forward.
- 8) Check foam sticking conditions around a shroud, F (U) and F (L) during assembling. If damaged, torn, or badly stuck, assemble with a new one after sealing well.

## 4. ICEMAKER ASSEMBLY

### 1. Dispenser Model

- 1) How to disassemble:
  - (1) Remove ice bin and shelf from the freezer compartment.
  - (2) Loosen four screws under part of icemaker.
  - (3) Disconnect icemaker housing.
  - (4) Loosen a screw on the bracket and lift up the Ice maker.
- 2) How to assemble: The assembly is the reverse order of the above disassembly.

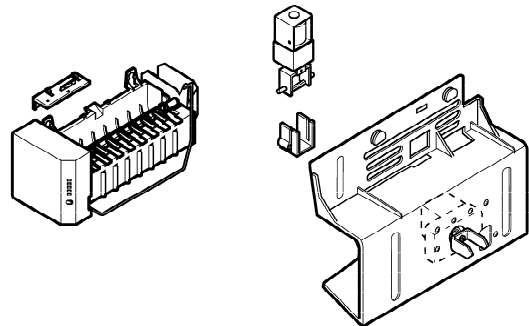

**Note :** When the ice tray is not horizontal after assembly, assembly must be wrong. Check and assemble again.



# HOW TO DISASSEMBLE AND ASSEMBLE

## 5. DISPENSER

1) Disconnect funnel and button assembly by pulling down and forward.

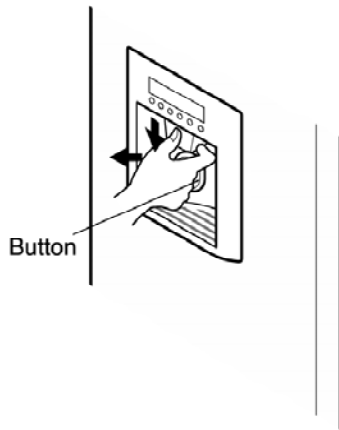

4) Loosen four screws with a phillips screwdriver and pull the funnel Assembly to disconnect.

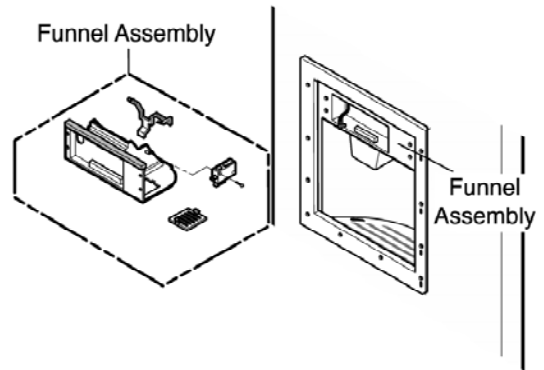

2) Remove display frame Assembly by making a gap between a display frame Assembly and funnel Assembly. with a balde screwdriver and pulling it forward. The cover dispenser is attached with a hook.

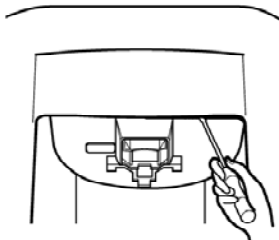

5) The Duct Cap Assembly can be disconnected if the hold lever connecting screw is loosened with a phillips driver.

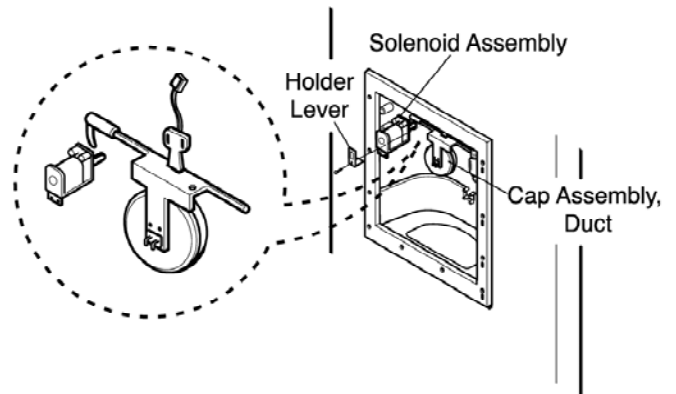

3) The Display Assembly can be connected by pressing the top of the dispenser cover and pushing it after separating the Display Frame from its housing.



6) To install the Duct Cap Assembly, insert one end of the spring into the right hole of the dispenser lever and insert the other end into the right hole in the top part of the dispenser. Then attach the holder at the solenoid switch.

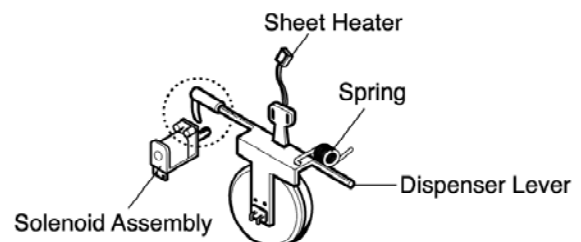

# TV-RADIO

---

## 1. SAFETY PRECAUTIONS

### 1-1. Warning

1. Be sure to make a safety check, if circuit is found, components that appear to have overheated or are otherwise damaged should be replaced with new components.
2. After servicing, be sure that the protected equipment is assembled.
3. When you don't watch TV, use the POWER button turn it off.

### 1-2. Notes

1. When inserting the instrument or circuit board, fix the leads to the jack, before soldering.
2. Insert higher voltage resistors with a 10mm gap above the PWB.
3. Don't touch hot chassis leads.

## 2. FEATURE

### 2-1. Auto Program tuning

All stations that can be received are stored.

### 2-2. Auto Sleep

TV will automatically switch itself to standby mode approximately ten minutes after TV station stops broadcasting.

### 2-3. Auto Search (FM RADIO)

Press the  RADIO button and then hold CH▲ or CH▼ button for more than 1 second to select RADIO Menu.

# TV-RADIO

## 3. CONTROLS

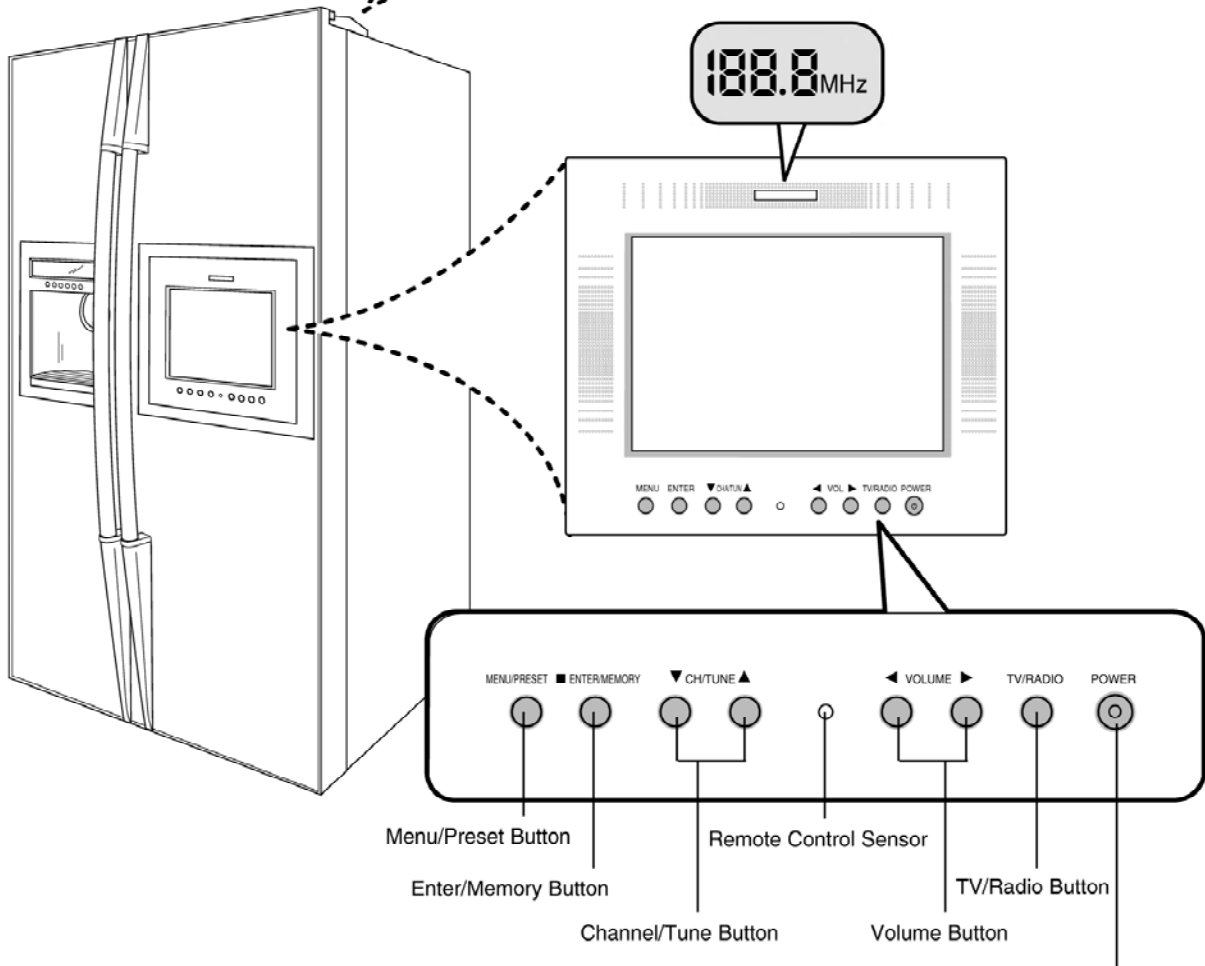
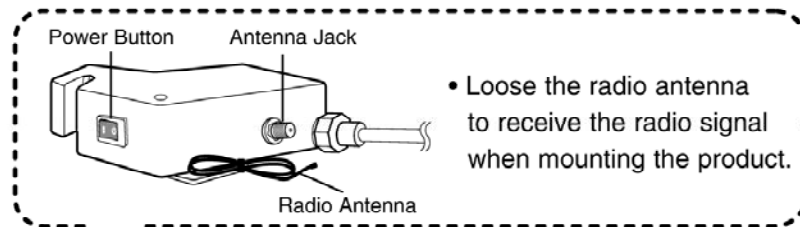

Power/Standby Indicator  
Glowes red in Standby mode,  
Glowes green when the TV is turned on.

# TV-RADIO

## 4. REMOTE CONTROL KEY FUNCTIONS

- When using the remote control, aim it at the remote control sensor on the TV.

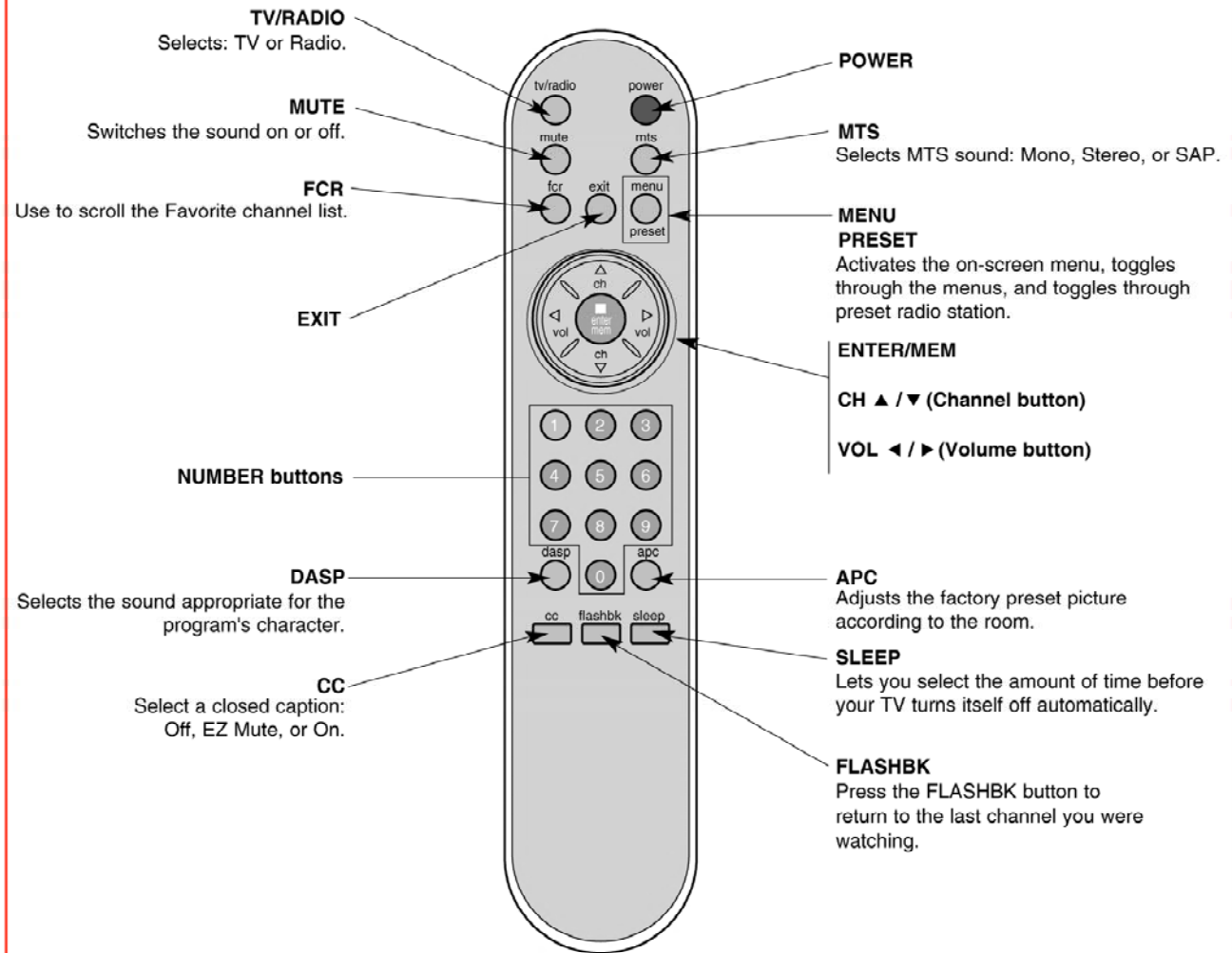

### Installing Batteries

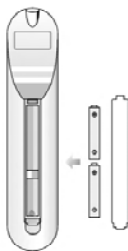

- Open the battery compartment cover on the back side and insert the batteries with correct polarity.
- Install two 1.5V batteries of AAA type. Don't mix used batteries with new batteries.

# TV-RADIO

## 5. TROUBLESHOOTING

### 5-1. General

No.	Poor	Symptoms	Adjustment
1	No Picture	1) No P1, P51, P52, P53, P54 connector 2) Poor TV Main PCB	1) Check P1 connector and switched on 2) Change the TV Main PCB
2	Poor Picture	1) Poor LCD Lamp 2) LCD Connector	1) Change the LCD 2) Check connector and switched on

### 5-2. TV

No.	Poor	Symptoms	Adjustment
1	No Sound	1) No P601, P602 connector 2) Poor speaker 3) Poor TV Main PCB	1) Check connector and switched on 2) Change the speaker 3) Change the TV Main PCB
2	Poor Radiant heat Fan	1) Fan turning abrades wire and tape. 2) Poor Fan	1) Detach Fan and remove the interference. 2) Change the Fan
3	No TV broadcast	1) No TV connection (Hinge Cover, Back TV)	1) Check connection and switch on
4	Button does not work	1) No P101 connector 2) Poor switch	1) Check connector and switch on 2) Change the Button PCB
5	Remote Control does not work	1) No P101 connector 2) Poor Remote Control sensor 3) Poor Remote Control	1) Check connector and switched on 2) Change the Button PCB 3) Change the Remote Control

### 5-3. FM Radio

No.	Poor	Symptoms	Adjustment
1	No Sound	1) Poor FM Radio Tuner	1) Charge FM Radio Tuner.
2 	Poor Display LCD	1) Poor Text Display 2) No Backlight	1, 2) Charge FM Radio LCD ASSEMBLY & Check Connector

# TV-RADIO

## 6. BLOCK DIAGRAM

### TV Ref. Function Block Diagram

TV can not make problem to the refrigerator.  
 < Separate circuit and controller.>

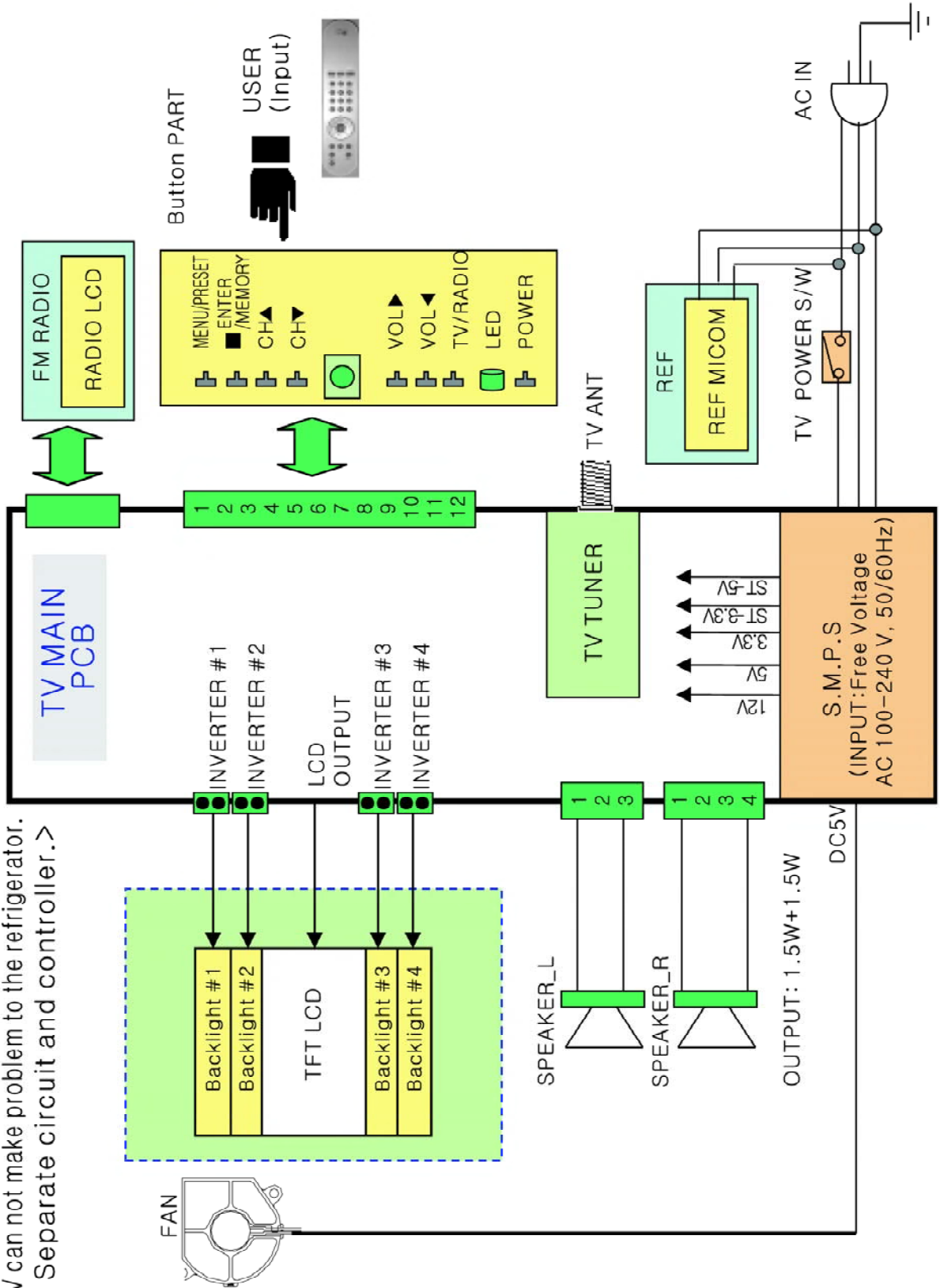

# TV-RADIO

## 7. TV PART DISASSEMBLE

**1** 

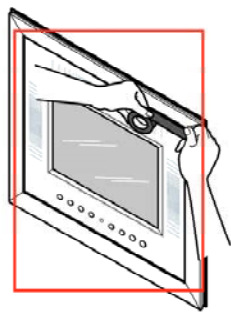

Place tape on the outer edge of the TV case to protect the soft plastic from damage (2 or 3 layers is recommended).

**2**

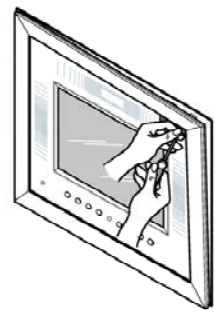

Using a flat bladed screwdriver, carefully pry the trim loose from the frame.

**3**

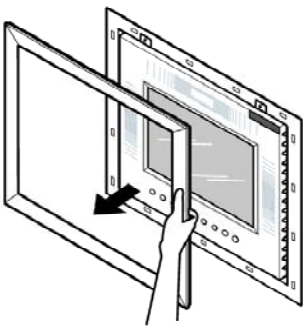

Carefully remove the trim.

**4**

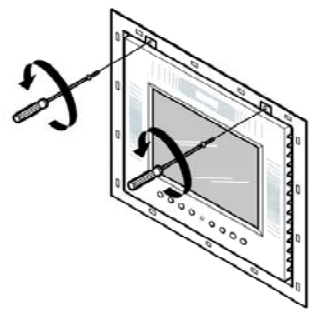

Remove two Phillips head screws located at the top of the TV.

**5** 

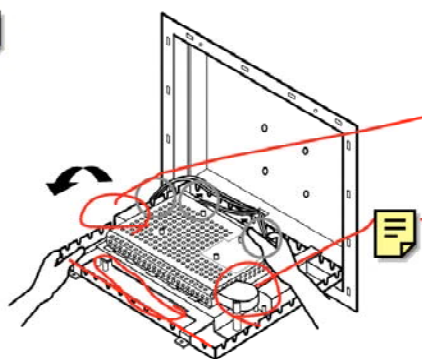

Tip the TV forward and disconnect all wires.

**6** 

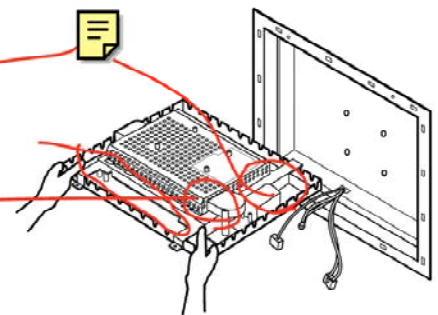

Carefully remove the TV.

# EXPLODED VIEWS

## DISPENSER RELATED PARTS

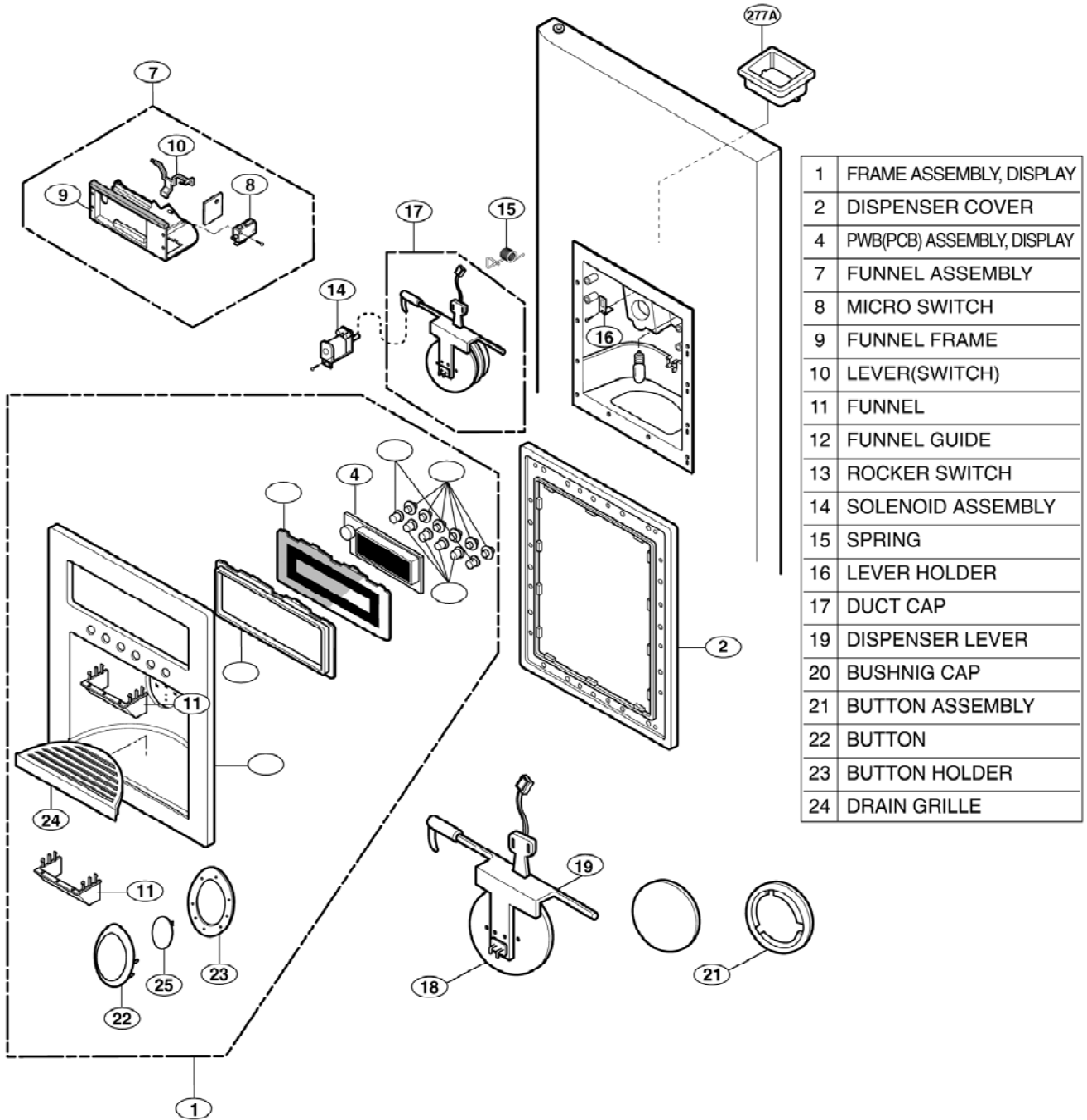

⑰ Cap Assembly, Duct Detailed Drawings



# EXPLODED VIEWS

**FREEZER DOOR PART: LRSC26920\*\*, LRSC26922\*\*, LRSC26930\*\*, LRSC26944\*\*, LRSC26980\*\***

\* : Optional part

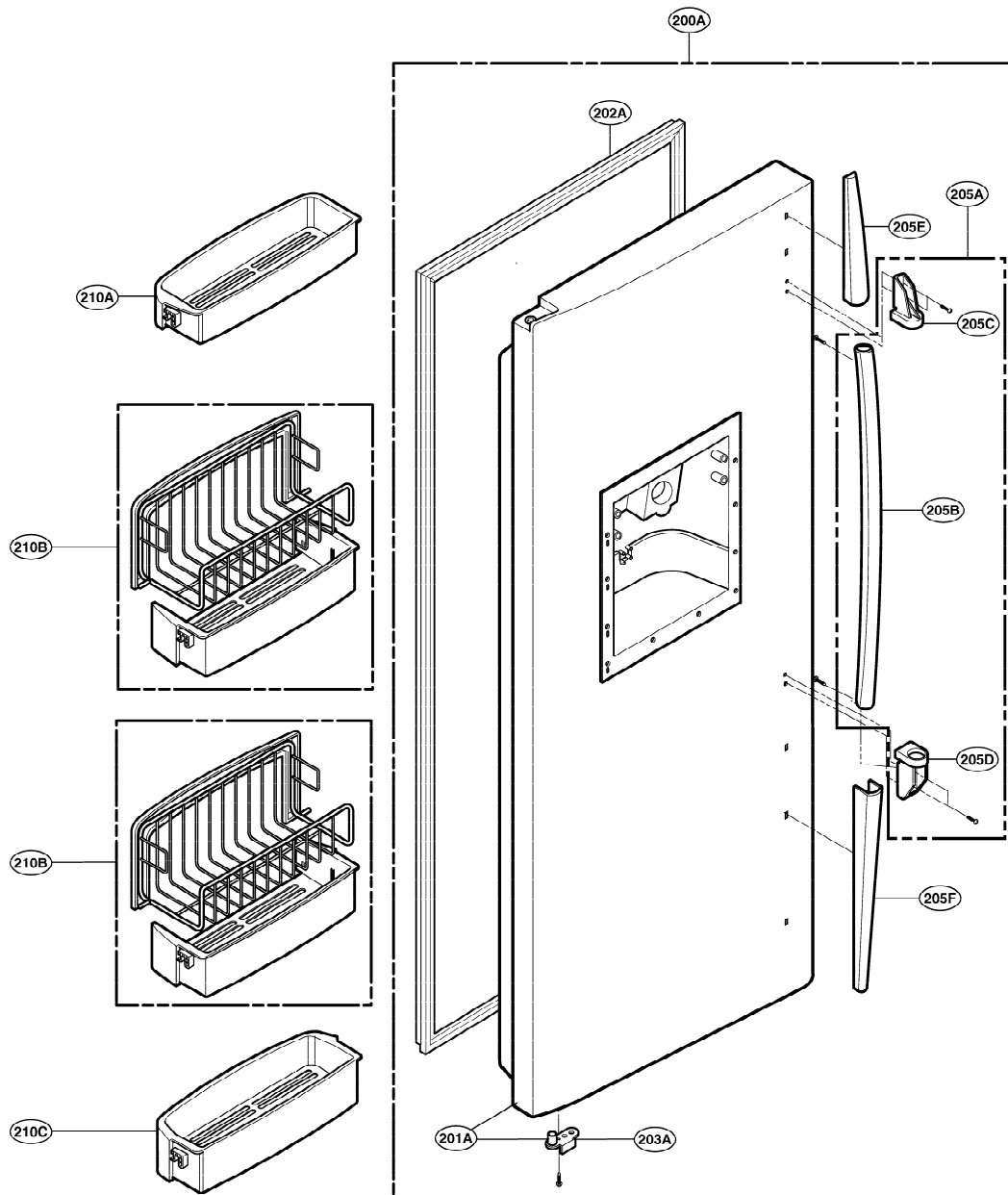

# EXPLODED VIEWS

REFRIGERATOR DOOR PART: LRSC26920\*\*, LRSC26922\*\*, LRSC26930\*\*, LRSC26944\*\*

\* : Optional part

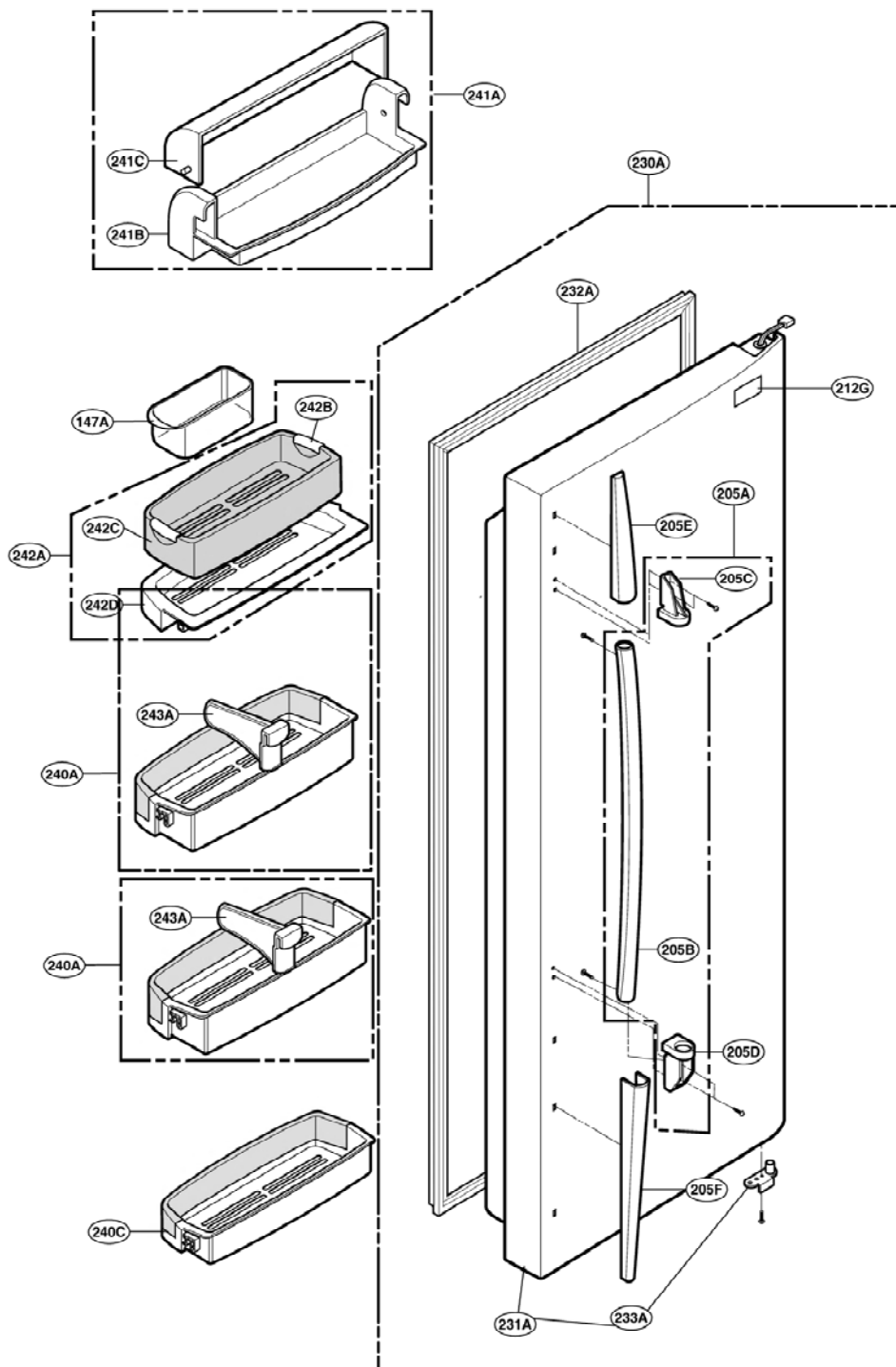

# EXPLODED VIEWS

**FREEZER COMPARTMENT: LRSC26920\*\*, LRSC26922\*\*, LRSC26930\*\*, LRSC26944\*\*, LRSC26980\*\***

\* : Optional part

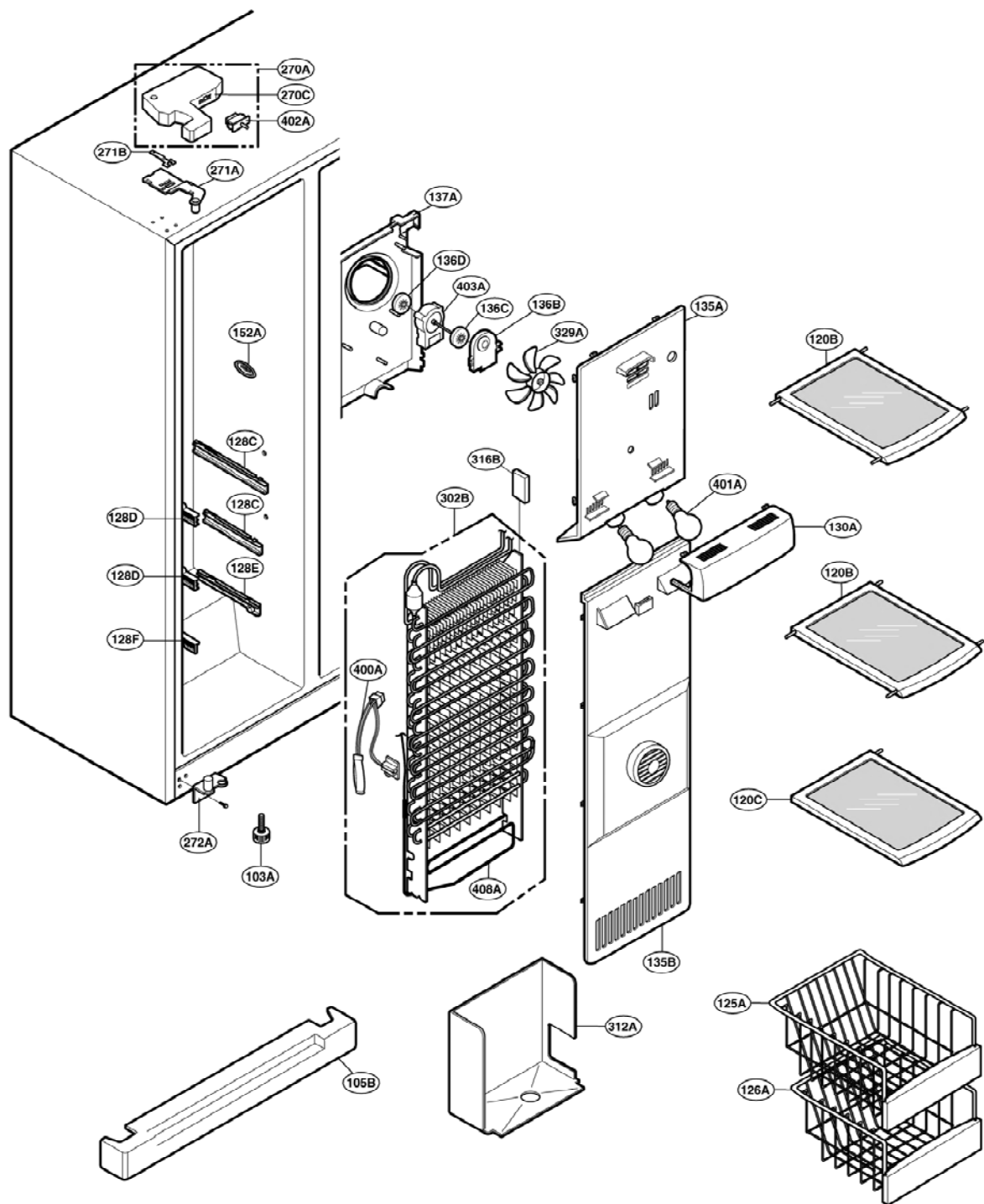

# EXPLODED VIEWS

REFRIGERATOR COMPARTMENT: LRSC26920\*\*, LRSC26922\*\*, LRSC26930\*\*, LRSC26944\*\*

\* : Optional part

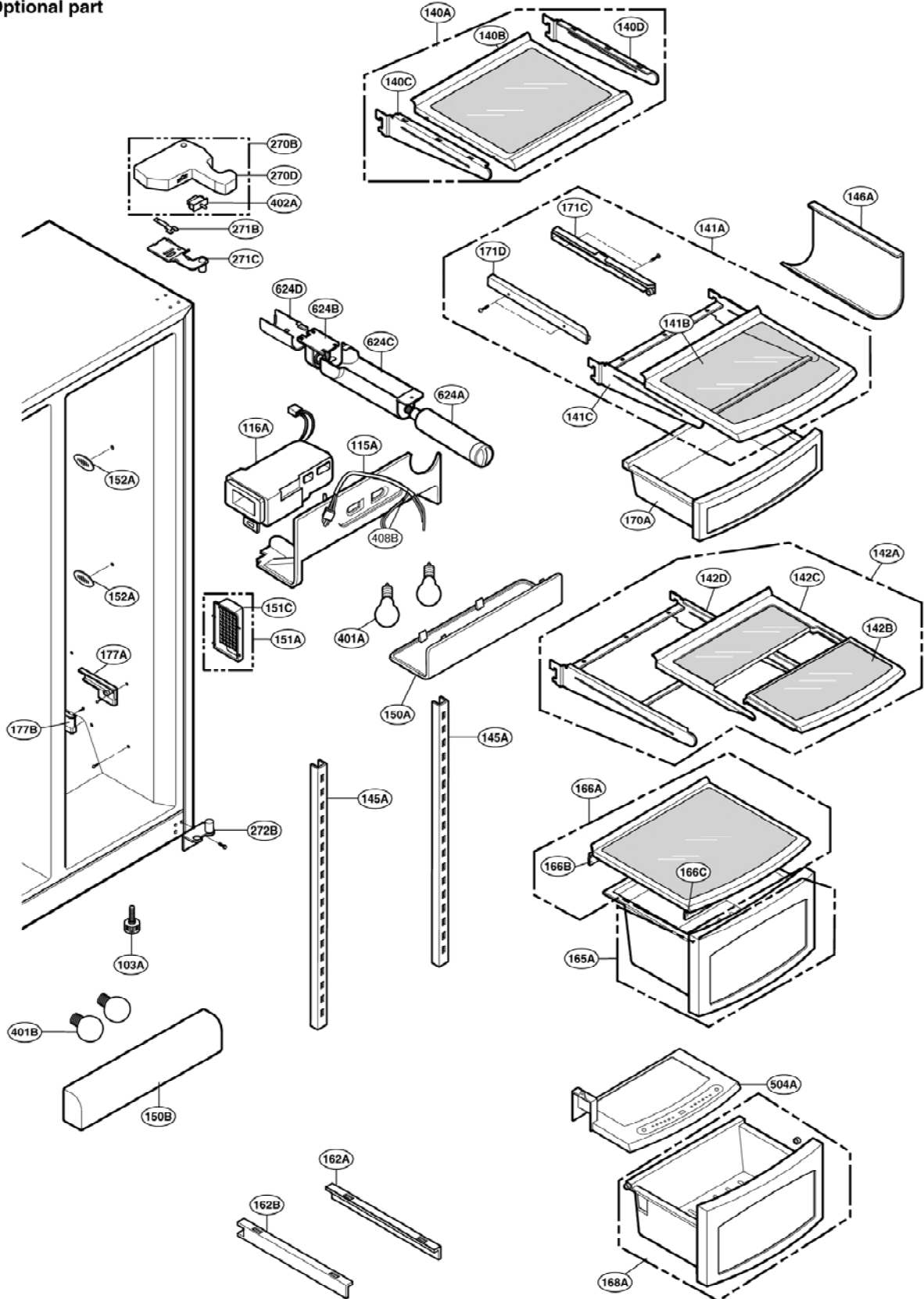

# EXPLODED VIEWS

ICE & WATER PART: LRSC26920\*\*, LRSC26922\*\*, LRSC26930\*\*, LRSC26944\*\*, LRSC26980\*\*

\* : Optional part

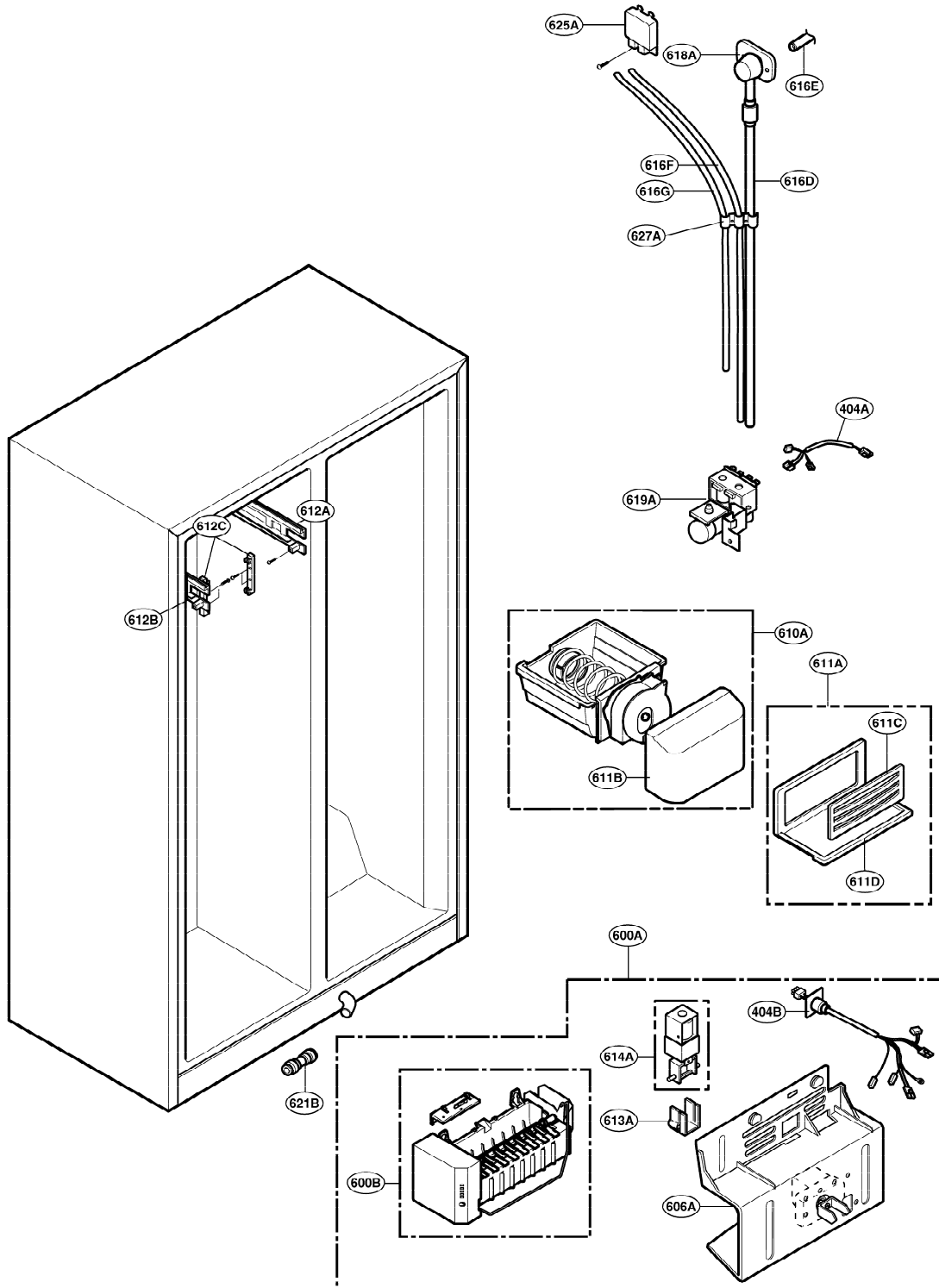

# EXPLODED VIEWS

MACHINE COMPARTMENT: LRSC26920\*\*, LRSC26922\*\*, LRSC26930\*\*, LRSC26944\*\*,  
LRSC26980\*\*

\* : Optional part

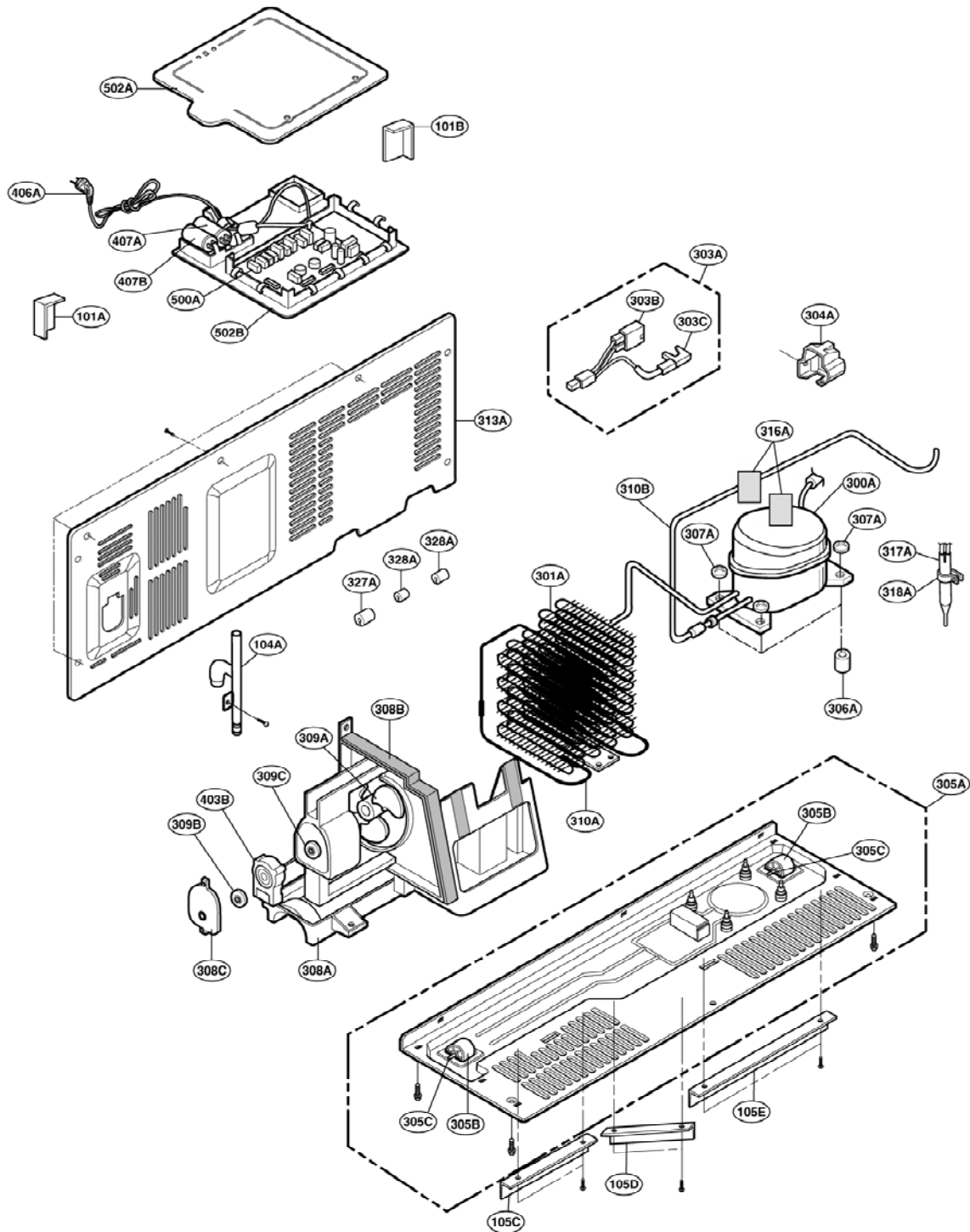

# EXPLODED VIEWS

DISPENSER PART: LRSC26920\*\*, LRSC26922\*\*, LRSC26930\*\*, LRSC26944\*\*, LRSC26980\*\*

\* : Optional part

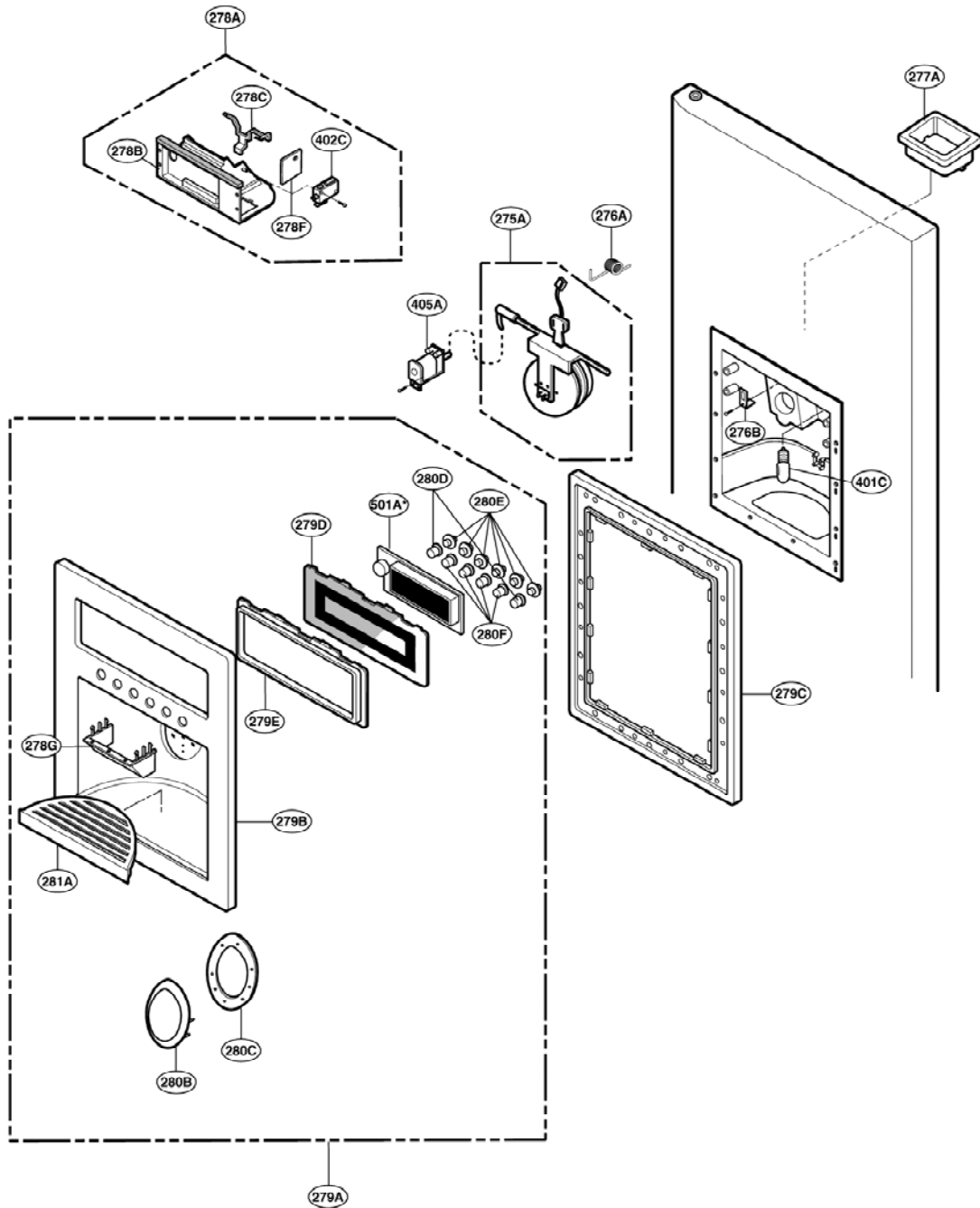



P/No. 3828JD8646A

FEB., 2004 Printed in Korea