

This Owner's Manual is provided and hosted by [Appliance Factory Parts](#).

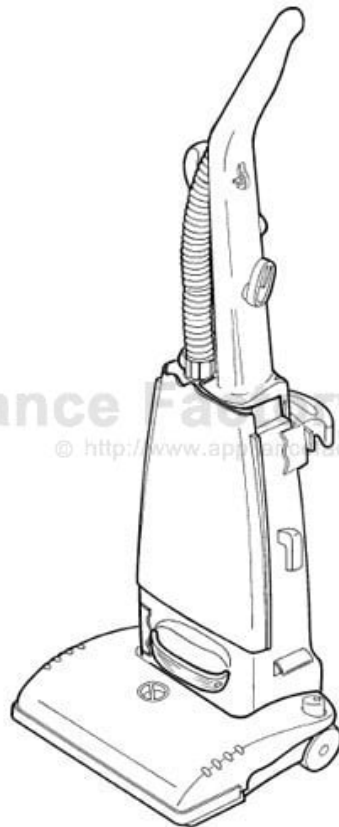

# Eureka 4470 Owner's Manual

[Shop genuine replacement parts for Eureka 4470](#)



[Find Your Eureka Vacuum Cleaner Parts - Select From 853 Models](#)

----- Manual continues below -----

# EUREKA

We live and breathe clean.™

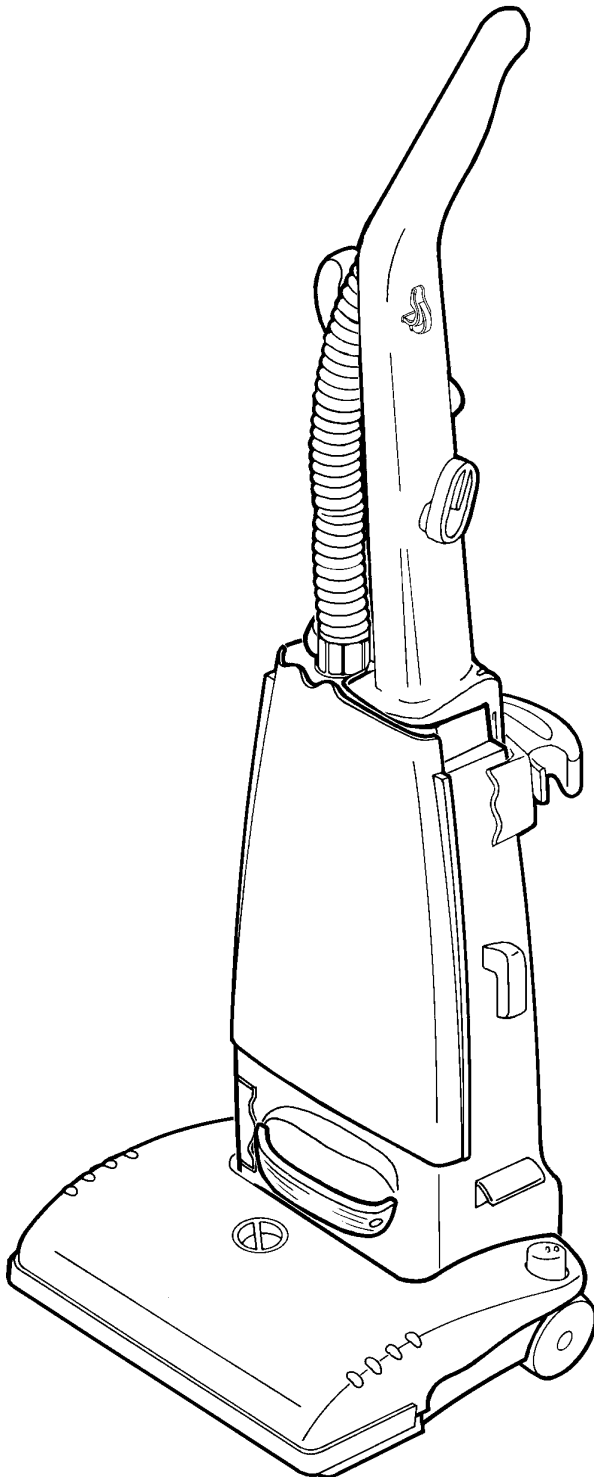

## Upright Vacuum Cleaner

Household Type

### Owner's Guide

4320 – 4370 Series

4440 – 4470 Series

### **IMPORTANT**

**Do not return this product to the store. For assembly problems or questions contact:** Eureka's Customer Service Division toll free at 1-800-282-2886\*, 8 a.m. to 7:30 p.m., (CST), Monday - Friday and 10 a.m. to 6:30 p.m. Saturday.

\*En Mexico llame al 5670-6169

[www.eureka.com](http://www.eureka.com)

### **PLEASE RETAIN**

We suggest you record the model, type and serial numbers below. They are located on the silver rating plate on your cleaner. For prompt and complete service information, always refer to these numbers when inquiring about service.

Model & Type \_\_\_\_\_

Serial No. \_\_\_\_\_

It is also important to keep your receipt as proof of date of purchase.

## Index

Important Safeguards .....	2
Service Information .....	3
Assembly .....	3-4
Use .....	5
Thermal Cut Off .....	3 & 5
Accessories .....	6
Brush Roll .....	7
Brush Roll Belt .....	7
Dust Bag .....	8
Hose Blockage .....	8-9
Filters .....	9-10
Warranty .....	10
Light Bulb .....	11
Problem Solving .....	11

# IMPORTANT SAFEGUARDS

When using an electrical appliance, basic precautions should always be followed, including the following:

**READ ALL INSTRUCTIONS BEFORE USING THIS VACUUM CLEANER.**

## WARNING

To reduce the risk of fire, electric shock, or injury.

- Do not use outdoors or on wet surfaces.
- **Do not leave vacuum cleaner when plugged in.** Turn off the switch and unplug the electrical cord when not in use and before servicing.
- Do not allow to be used as a toy. Close attention is necessary when used by or near children.
- Use only as described in this manual. Use only manufacturer's recommended attachments.
- Do not use with damaged cord or plug. If vacuum cleaner is not working as it should, has been dropped, damaged, left outdoors, or dropped into water, return it to a service center before using.
- Do not pull or carry by cord, use cord as a handle, close a door on cord, or pull cord around sharp edges or corners. Do not run vacuum cleaner over cord. Keep cord away from heated surfaces.
- Do not use extension cords or outlets with inadequate current carrying capacity.
- Turn off all controls before unplugging.
- Do not unplug by pulling on cord. To unplug, grasp the plug, not the cord.
- Do not handle plug or vacuum cleaner with wet hands.
- Do not put any object into openings. Do not use with any opening blocked; keep free of dust, lint, hair, and anything that may reduce airflow.
- This vacuum cleaner creates suction and contains a revolving brush roll. Keep hair, loose clothing, fingers, and all parts of body away from openings and moving parts.
- Do not place cleaner on furniture or stairs as the brush roll may cause damage. Place cleaner on floor with the handle in storage position while using attachments.
- Do not pick up anything that is burning or smoking, such as cigarettes, matches, or hot ashes.
- Do not use without dust bag in place.
- Belt pulleys can become hot during normal use. To prevent burns, avoid touching the belt pulley when servicing the drive belt.
- Use extra care when cleaning on stairs.
- Do not use to pick up flammable or combustible liquids such as gasoline, or use in areas where they may be present.
- Store your cleaner indoors in a cool, dry area.
- Keep your work area well lighted.
- Unplug electrical appliances before vacuuming them.

## SAVE THESE INSTRUCTIONS

To reduce the risk of electric shock, this appliance has a polarized plug (one blade wider than the other). This plug will fit in a polarized outlet only one way. If the plug does not fit fully in the outlet, reverse the plug. If it still does not fit, contact a qualified electrician to install the proper outlet. Do not change the plug in any way.

## GENERAL INFORMATION

The cleaner is designed to pick up dirt and dust particles. Avoid picking up hard or sharp objects with the cleaner to prevent bag tears, hose clogs, and fan blade breakage with subsequent motor damage.

## Service Information

The instructions in this booklet serve as a guide to routine maintenance. For additional service information telephone our toll free number for the nearest Eureka Authorized Warranty Station. **You should know the model, type and serial numbers when you call:**

**USA: 1-800-282-2886**  
**Mexico: 5670-6169**  
**Canada: 1-800-282-2886**

If you prefer, you can write to:

The Eureka Company, Service Division, 807 North Main Street, Bloomington, Illinois 61701, USA.

In Canada write to The Eureka Company, 866 Langs Drive, Cambridge, Ontario N3N 2N7.

Refer to The Eureka Limited Warranty for complete service information.



**DO NOT OIL** the motor or the brush roll at any time. The bearings are permanently lubricated and sealed.

## Thermal Cut Off

This vacuum cleaner has a special thermostat that protects the cleaner in case of motor overheating. If the cleaner suddenly shuts off, push the switch pedal once and unplug the cleaner. Check the cleaner for a possible source of overheating such as a full bag, a blocked hose or clogged filter. If these conditions are found, fix them and wait at least 30 minutes before attempting to use the cleaner. After the 30 minute period, plug the cleaner back in and turn on the switch. If the cleaner still does not run, then take it to a Eureka Authorized Service Center for repair.

## HOW TO ASSEMBLE



**CAUTION:** Assemble the cleaner before using.



**CAUTION:** Moving parts, make sure on/off switch is in off position before plugging in.



**NOTE:** Features may vary by model yet all parts assemble the same.

### Step A Attach Hose

(Refer to your hose adapter style)

1. Remove the front bag cover. (Only required with Style B adapter.)
2. Locate the tab on the hose adapter of the extension hose (shortest end). There are two styles, either A or B. Each style assembles identically.
3. Insert hose adapter into opening on top of unit. **The hose adapter tab must be placed all the way down into the notch.**

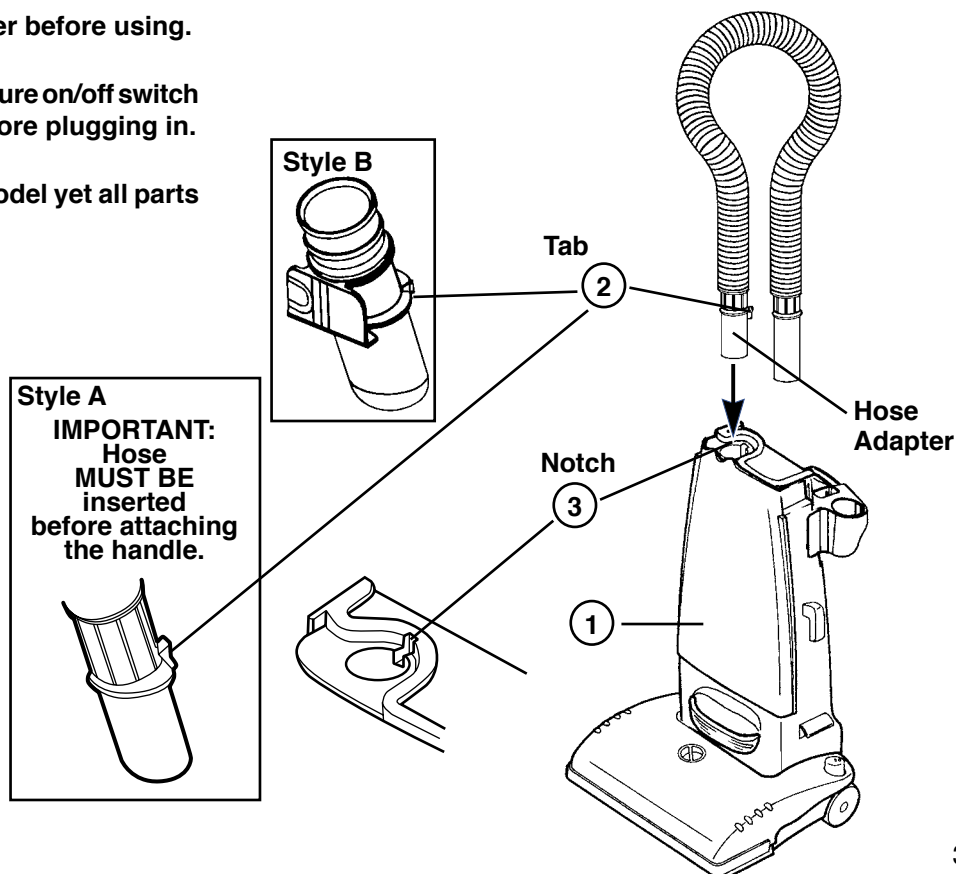

# HOW TO ASSEMBLE (Continued)

## Step B Attach Handle

**CAUTION:** Do not catch cord under handle.

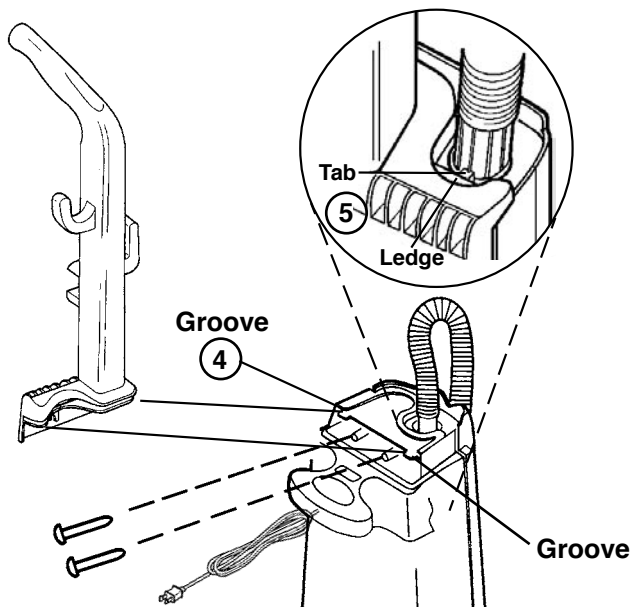

4. From rear of cleaner, align handle with groove and slide onto cleaner. If necessary, use thumb and finger pressure to slide handle into position.
5. Once handle is in place, check that the hose adapter tab is completely secure **under** the ledge of the handle.
6. Attach handle with two 5/8 inch screws in the assembly packet. Use either a slotted or Phillips® head screwdriver.
7. Replace front cover.

## Step D Check Disposable Dust Bag

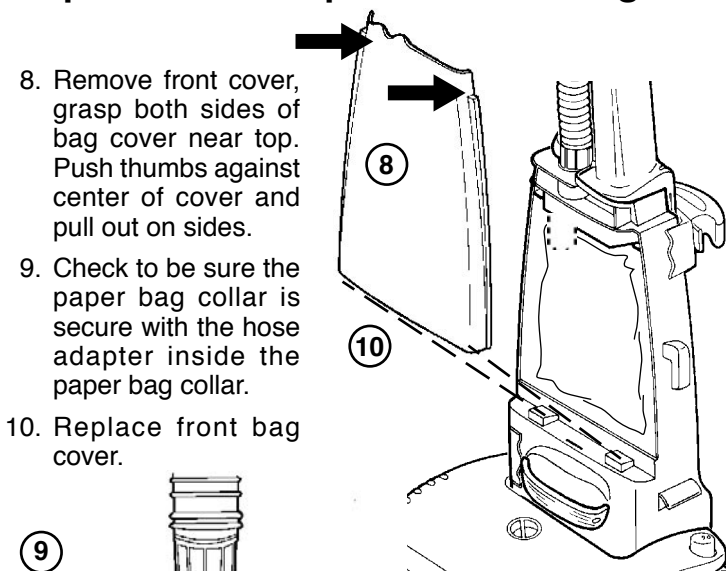

8. Remove front cover, grasp both sides of bag cover near top. Push thumbs against center of cover and pull out on sides.
9. Check to be sure the paper bag collar is secure with the hose adapter inside the paper bag collar.
10. Replace front bag cover.

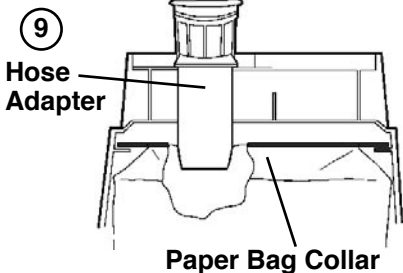

## Step C Store Hose and Accessories

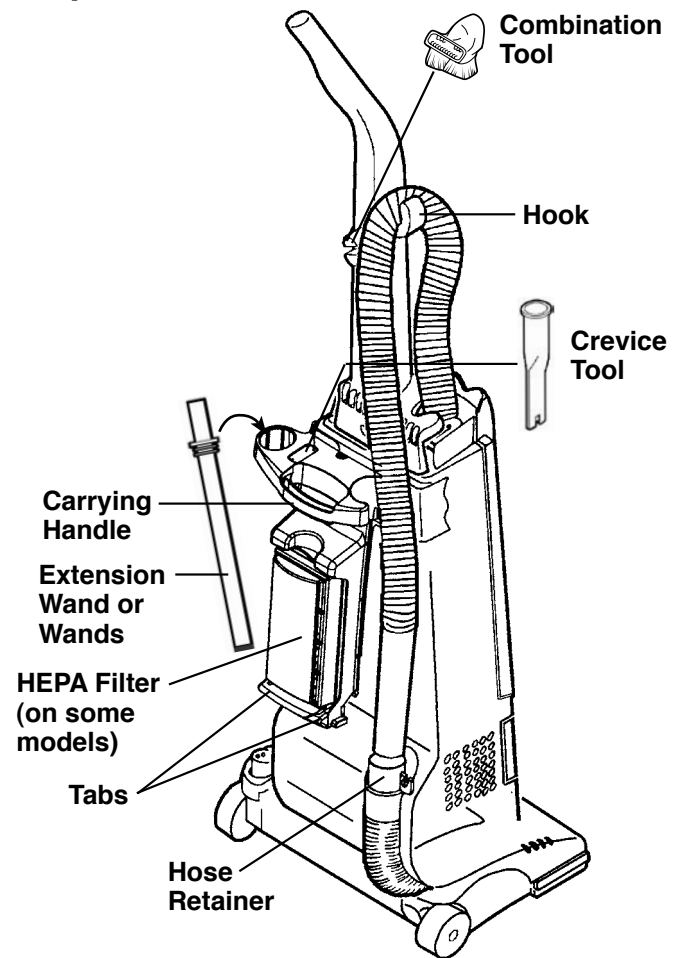

## Step E Store Electrical Cord

11. You will find your cord retainer either at the bottom of the upper cord hook or on the handle above the upper cord hook. Firmly push the electrical cord down into either cord retainer. This will place the cord out of the way the next time you vacuum.
12. Next wind the cord around the two cord hooks on the left side of cleaner. On some models the upper cord hook turns to release the cord. Turn the hook up to store the cord.

**NOTE:** For easier access to bag compartment, when you store the electrical cord use a figure 8 pattern.

13. Secure the plug to the cord to prevent unwinding.

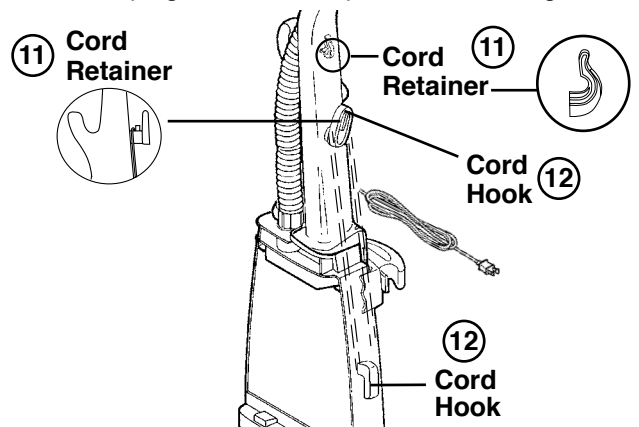

# HOW TO USE

The upright vacuum cleaner design allows use on multiple types of carpeting and on upholstery or bare floors with attachments. **When using the attachment tools, place the handle in the upright position. Do not place cleaner on furniture or steps as the brush roll may cause damage.**

1. Adjust cleaner height setting knob to lowest position for maximum cleaning. Adjust to a higher setting to make pushing easier. For easy adjustments, tilt the cleaner back to move the setting knob.
2. Unwind all of the electrical cord. Located above the cord hook is the cord retainer. Firmly push the electric cord down into the cord retainer. Using the cord retainer will keep the electric cord up, out of the way while vacuuming.
3. Plug electrical cord into outlet.
4. Step on handle release. Pull handle back to a comfortable position.
5. Push On or Off power switch.

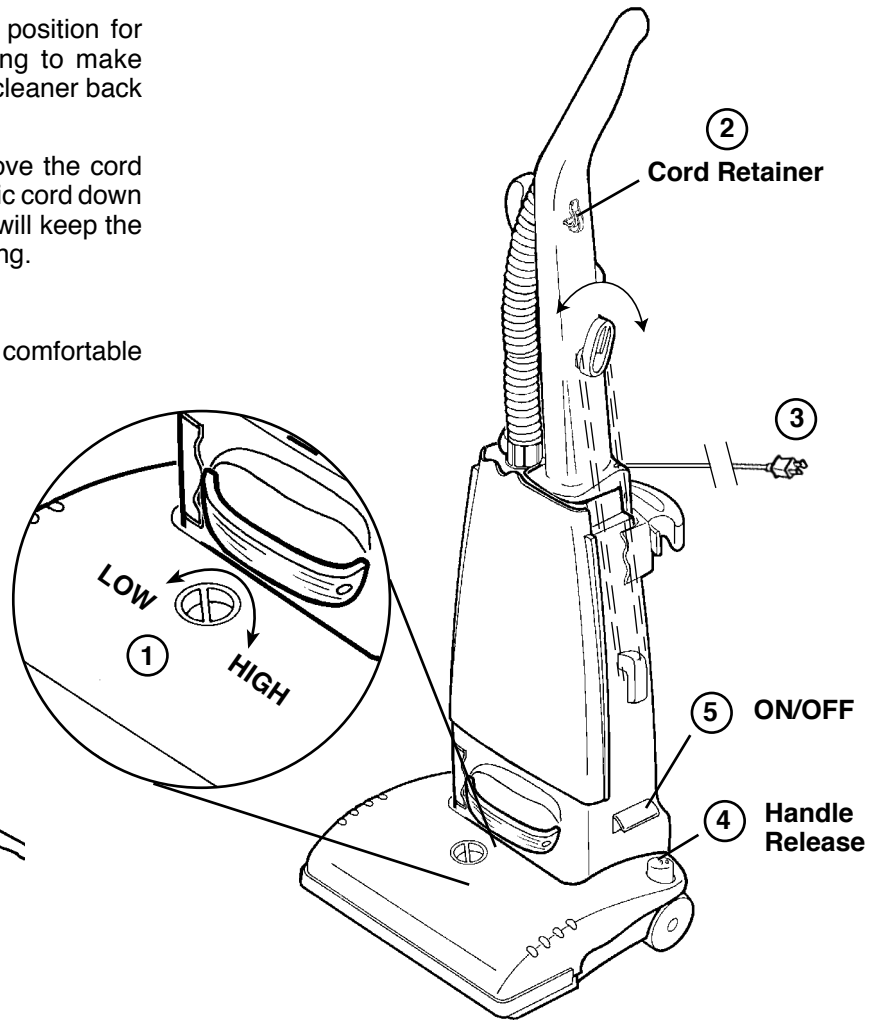
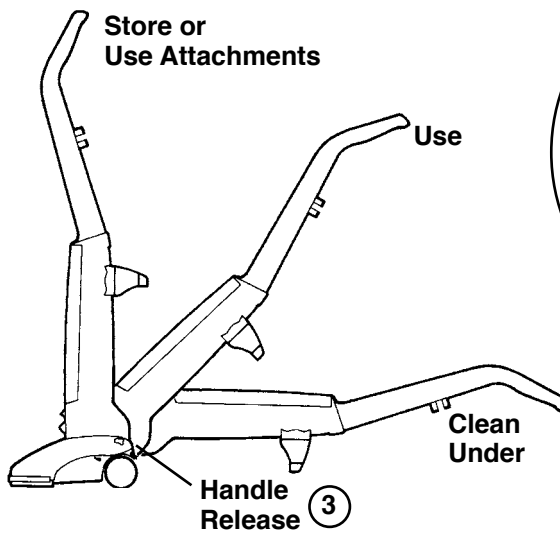

## Cleaner Height Setting

**! WARNING:** Avoid injury. Keep loose clothing, hair, fingers, and all other parts of body away from any moving part (such as the revolving brush). Turn off the switch and unplug the cleaner before changing the cleaner height setting.

The front of the cleaner has an adjustment that raises or lowers the cleaner base to match the type of carpet. With the cleaner cord unplugged, set the adjustment to lowest setting for maximum cleaning. If the cleaner is difficult to push, move adjustment to next highest setting until cleaner is comfortable to push. The brush roll must reach the carpet for effective cleaning.

**! NOTE:** For ease in moving the adjustment knob, place handle in operating position and tilt cleaner back to remove weight from front wheels.

**! NOTE:** When handle is in upright position, brush roll is lifted off carpet. This is normal. Height adjustment will not change brush roll level until the cleaner's handle is moved into the operating position.

## Thermal Cut Off

This cleaner has a special thermostat that protects the cleaner in case of motor overheating. If the cleaner suddenly turns off, follow this procedure:

1. Push on/off pedal once.
2. Unplug cleaner.
3. Check for source of overheating problem (i.e. full bag, clogged hose or clogged filter).
4. If a full bag, clogged hose or clogged filter is found, replace the bag, unplug the hose or replace the filters.
5. Wait at least 30 minutes before attempting to reuse the cleaner.
6. After 30 minute cool down period, plug the cleaner in and push the switch pedal. The cleaner should turn on.
7. If the cleaner still does not operate, take it to any Eureka Authorized Service Center for repair.

# How To Use Accessories

**NOTE:** Do not place cleaner on furniture or steps as the brush roll may cause damage. Place cleaner on floor with the handle in storage position while using accessories.

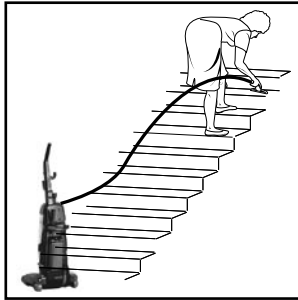

**Always work with the cleaner below you, pulling hose from side of cleaner; not the back or the front of the cleaner.**

**NEVER STAND ANY CLEANER ABOVE YOU.**

**NEVER POSITION ANY CLEANER ON THE STAIRS AS THIS COULD DAMAGE THE CARPET.**

Depending on which cleaner you purchased, you can have any combination of the following accessories.

1. Remove hose from rear of cleaner.
2. Place desired accessory onto end of hose or wand.

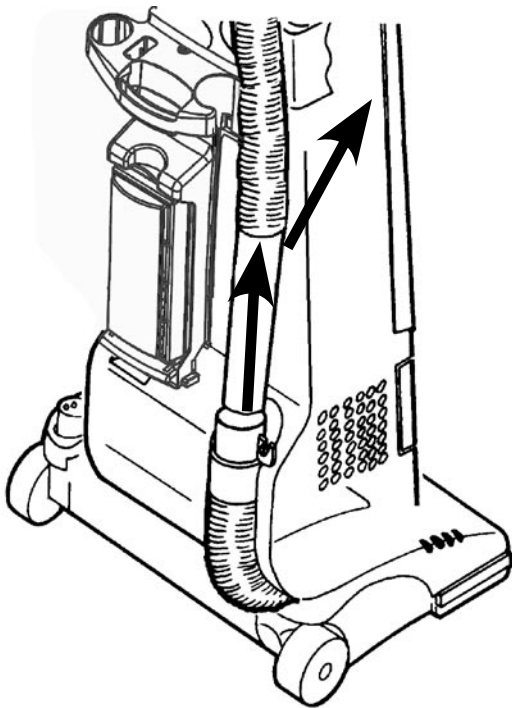

**Dusting Brush** is for furniture, blinds, books, lamp shades, shelves. (On some models.)

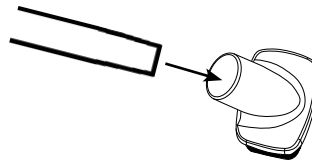

Dusting Brush

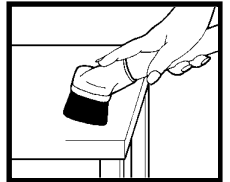

**Upholstery Nozzle** is for curtains, draperies, cushions, fabrics. (On some models.)

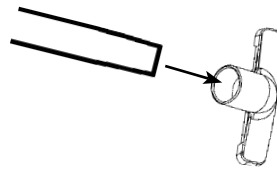

Upholstery Nozzle

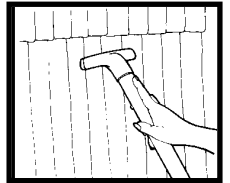

**Combination Tool** gives two types of cleaning tools. (On some models.)

- Use brush side to dust furniture, blinds, books, lamps, shelves.
- Use upholstery side for curtains, draperies, cushions, fabrics.

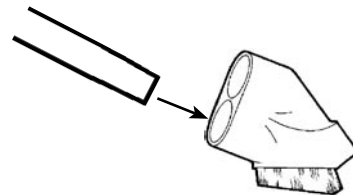

Dusting Side

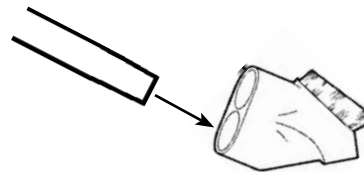

Upholstery Side

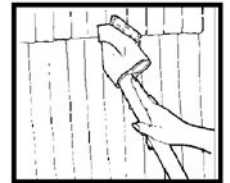

**Crevice Tool** cleans corners, baseboards, between cushions.

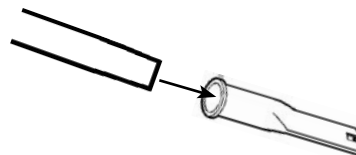

Crevice Tool

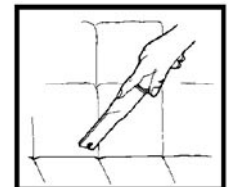

**Extension Wands** (Some models use 1 wand)

**Nested Extension Wands** to add reach.

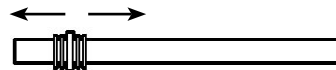

- Grasp both wands near ridges.

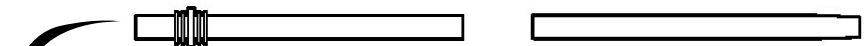

- Pull apart.

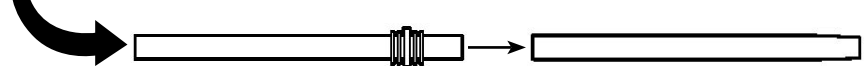

- Turn ridge end to center.
- Push wands together.

# HOW TO MAINTAIN

The instructions in this booklet serve as a guide to routine maintenance. To avoid unnecessary service calls, check the bag, belt, and brush roll often.

## Brush Roll

The brush roll turns as it sweeps and combs the carpet nap. Remove hair and threads from the brush roll so it continues brushing the carpet. To maintain the most efficient cleaning, the bristles must touch the carpet. To test the bristle length, hold a ruler against the underneath side of the cleaner. If the bristles no longer touch the ruler, replace the brush roll.

## Brush Roll Belt

The brush roll belt turns the brush roll to agitate, sweep, and comb the carpet nap. Check the belt regularly to be sure it is in good condition. Replace the belt if it stretches, cracks or loses tension. Cut away any hair or threads wound around the brush roll or the belt pulley because the buildup could cause the belt to rotate unevenly.

## How To Replace Brush Roll Belt

**NOTE:** Turn off the switch and unplug the electrical cord before replacing belt. Belt pulleys can become hot during normal use. To prevent injury, avoid touching the motor pulley when checking the belt.

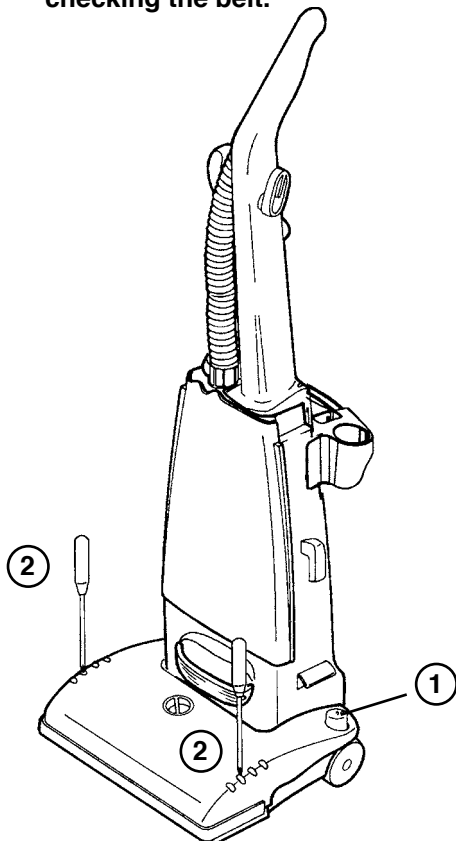

1. Lower handle to floor to change belt.
2. Loosen, but do not remove, two screws to release hood. Lift hood to remove.

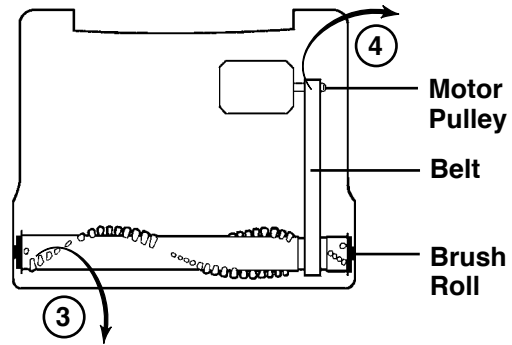

3. Lift left end of brush roll.
4. Remove and discard belt.

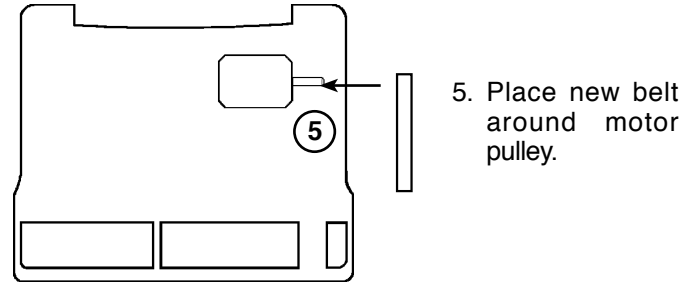

5. Place new belt around motor pulley.

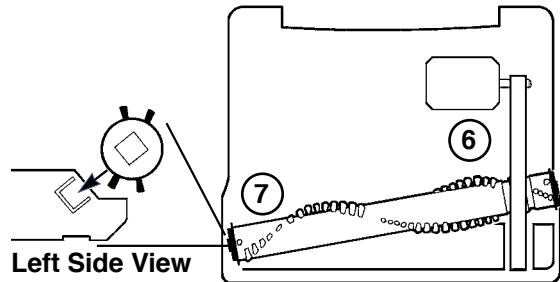

6. Place belt around brush roll pulley.
7. Align left end cap with square in base. Push end cap into place; see left side view.

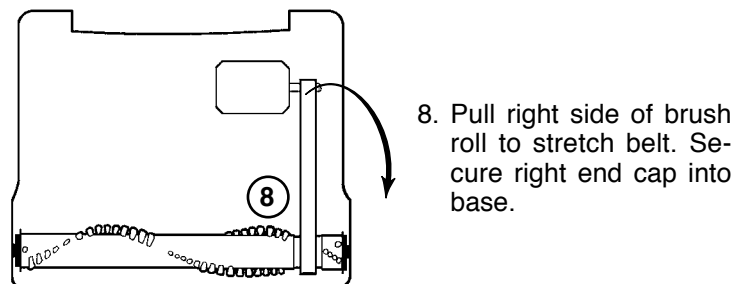

8. Pull right side of brush roll to stretch belt. Secure right end cap into base.

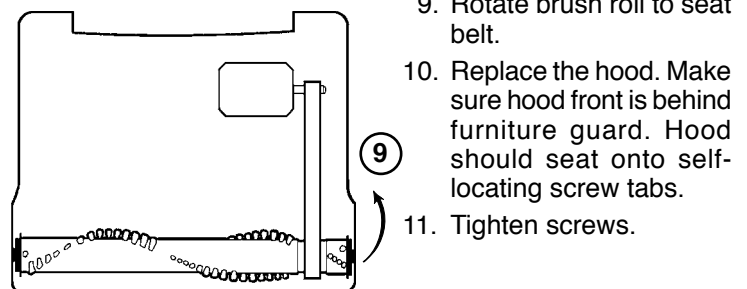

9. Rotate brush roll to seat belt.
10. Replace the hood. Make sure hood front is behind furniture guard. Hood should seat onto self-locating screw tabs.
11. Tighten screws.

**Use GENUINE EUREKA replacement belt, 54312. Look for the GENUINE EUREKA product symbol.**

# HOW TO MAINTAIN (Continued)

## Disposable Dust Bag and Filters

The disposable dust bag plays a very important role in the efficiency of a vacuum cleaner. The purpose of the paper bag is to trap dirt. As the bag traps dirt, it must also be porous enough to allow air to pass on through. If the paper bag becomes clogged, no air can pass through the cleaner and no cleaning can take place regardless of how powerful the unit. Change the dust bag and check the filters frequently. Some fine particles can restrict airflow very quickly and will decrease performance even before the bag appears to be full.

When vacuuming carpet fresheners or cleaners, powder, plaster dust, or similar fine substances, the bag and filters may require more frequent maintenance.

## How To Replace Bags—Style AA Filteraire

**NOTE:** Turn off the switch and unplug the electrical cord before changing dust bag. Never operate the vacuum cleaner without the dust bag or the filter.

**NOTE:** Style AA Filteraire bags must be used to maintain HEPA grade filtration and prolong the life of the HEPA filter. Also use AA Filteraire bags to maintain Micron grade filtration and prolong the life of the Micron filter.

**NOTE:** Models without HEPA or Micron filter option, may use Style AA bags rather than Style AA Filteraire.

It may be more convenient to lower the handle to the floor before changing the bag.

\* We recommend using only Genuine Eureka Filteraire Bags, part number 58623.

## How to Check and Clear Hose Blockages

Low suction or poor pickup may be due to a blockage in the vacuum cleaner.

1. Remove hose and check suction at end of hose - if little or no suction, check disposable dust bag. Change if needed. If no improvement proceed to step 2.

**NOTE:** Turn off the switch and unplug the electrical cord before clearing hose.

2. Remove the handle from the vacuum cleaner by removing the two screws and sliding the handle towards the rear.
3. Once the handle is removed, disconnect the attachment hose from the unit by lifting straight up on the hose adapter.

Check for any obstructions that may be in the hose. Any obstructions can be removed by using a blunt instrument to clear the hose. Flexing the hose may help loosen the clog.

4. Reinstall the hose after clearing the clog. Make sure the hose is inserted into the top of the vacuum cleaner before reattaching the handle.

**NOTE:** If no improvement in performance on carpet, proceed to following page.

## To Remove Bag:

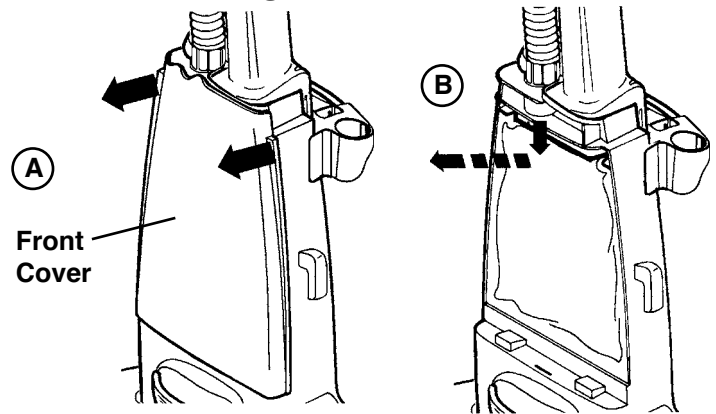

- A. Remove front cover. Grasp both sides of bag cover near top. Push thumbs against center of cover and pull out on sides.
- B. Grasp bag collar; pull down slightly and out to remove bag.

## To Replace New Bag:

- C. Fold sides of paper bag below bag collar.
- D. Align bag collar hole and notch with hose adapter.
- E. Place bag collar corners on ledges. Push collar to rear of compartment. **Check to be sure hose adapter inserts into bag collar.**

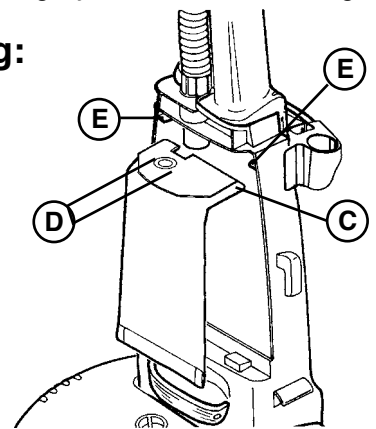

- F. Tuck bag into bottom and along sides.
- G. Replace front cover. Make sure disposable bag does not catch under front cover.

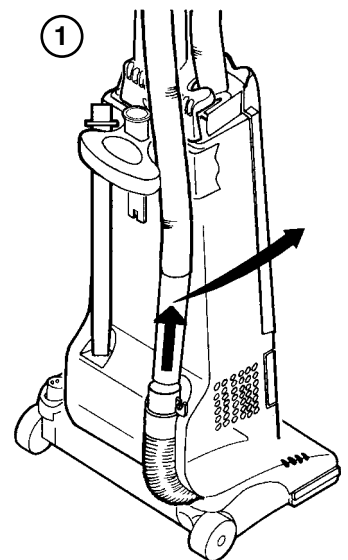

1. Remove hose and check suction at end of hose.

## How to Check and Clear Hose Blockages (Continued)

2. Remove handle.
3. Disconnect hose.

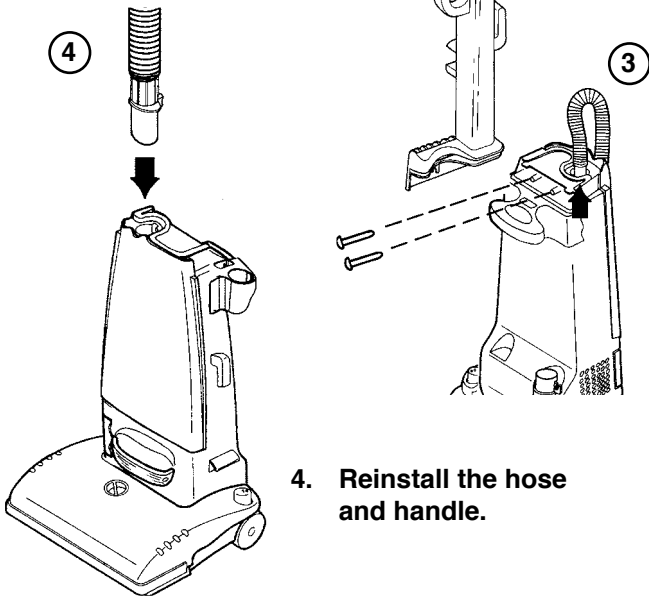

## HEPA Cartridge Filters

(Only for models with HEPA cartridge.)

Check the HEPA filters with each disposable dust bag change. Replace twice a year or after every six bag changes.

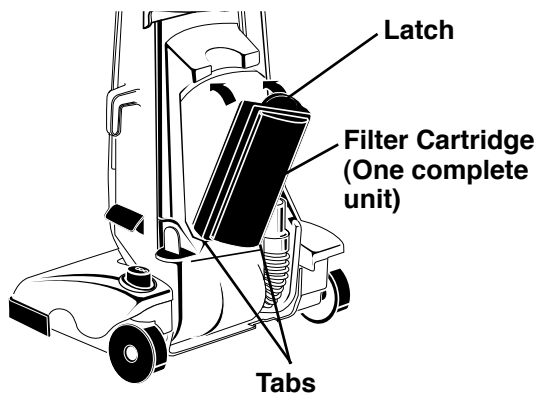

### To remove HEPA cartridge filters

1. Push down latch and pull filter cassette back.
2. Then lift filter up and remove.

### To replace HEPA cartridge filters

1. Place bottom tabs of filter cassette into slots.
2. Rotate filter toward cleaner.
3. Push upward on the latch to secure into place.



**NOTE:** To have the benefit of a sealed HEPA system, you must use one of the HEPA cartridge filter systems.

## How to Check and Clear Blockages in Base

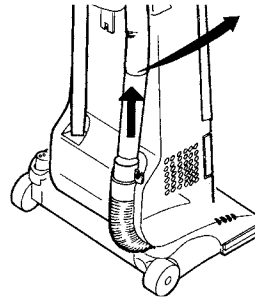

1. Remove the attachment hose from the lower hose retainer and look into the hose retainer for any obstructions. Proceed to Step 2 to check for any other blockages.

2. Remove the hood by loosening the two screws located on the top of the hood and lifting upward.

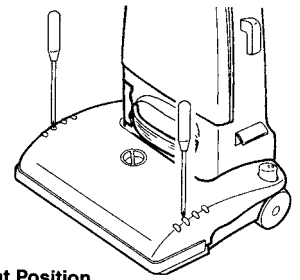

3. Step on the handle release and lower the handle all the way to the floor.

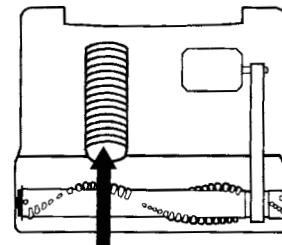
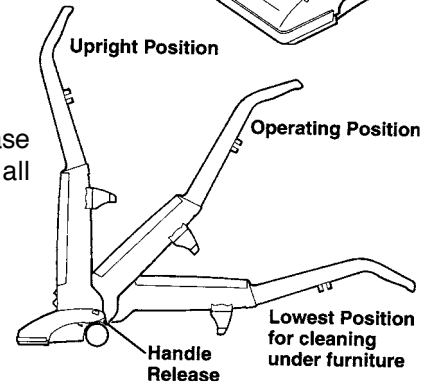

4. Check for blockages in the brush roll area and remove any obstructions found there. The base hose can be cleared of any blockage by using a blunt instrument.

5. After the blockage is removed, replace the hood and tighten the two hood screws (see Fig. 2). Raise the handle to the upright position (see Fig. 3) and replace the hose into the lower hose retainer.

## HEPA/Micron Filters in Filter Frame (Only for models with HEPA/Micron filter frame)

Check the HEPA/Micron filter with each disposable dust bag change. Replace twice a year or after every six bag changes.

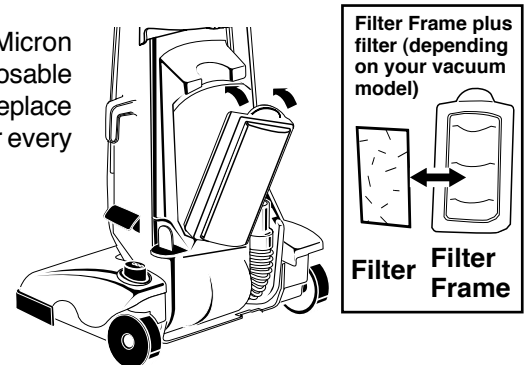

### To remove HEPA/Micron filters from filter frame.

1. Push down latch and pull filter frame back.
2. Then lift filter up and out of filter frame.

### To replace HEPA/Micron filters into filter frame.

1. Place new filter in filter frame. Place bottom tabs of filter frame into slots.
2. Rotate filter frame toward cleaner.
3. Push upward on the latch to secure into place.

## Motor Filter

Check the motor filter with each disposable dust bag change. Clean or replace as needed.

## To Clean Motor Filter

1. Remove filter from inside bag compartment, lower left side.
2. Shake filter to remove excess dust. If necessary, the filter can be cleaned by vacuuming with another cleaner.
3. Reinstall filter with stiff/printed side down. Slide under back ledge and filter retainer. Install with colored/smooth side down.

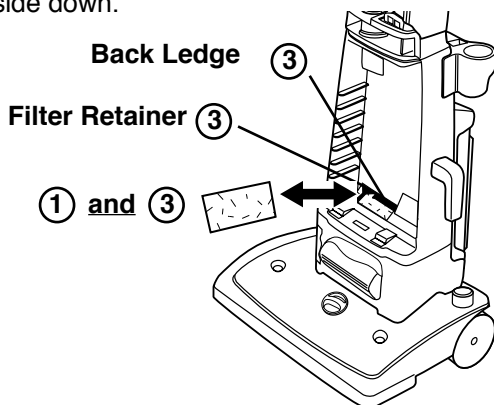

## Micron and HEPA Exhaust Filters (Only for models with the exhaust filter door)

Change micron or HEPA exhaust filter every 3 months.

## To Replace Micron or HEPA Exhaust Filter

1. Lower the handle. Open exhaust filter door; push toward the left side.
2. Grasp filter and pull out.
3. Push new filter into cleaner, smooth side facing out.
4. Close exhaust filter door; push toward right side.

Replace all filters with genuine Eureka replacement filters.

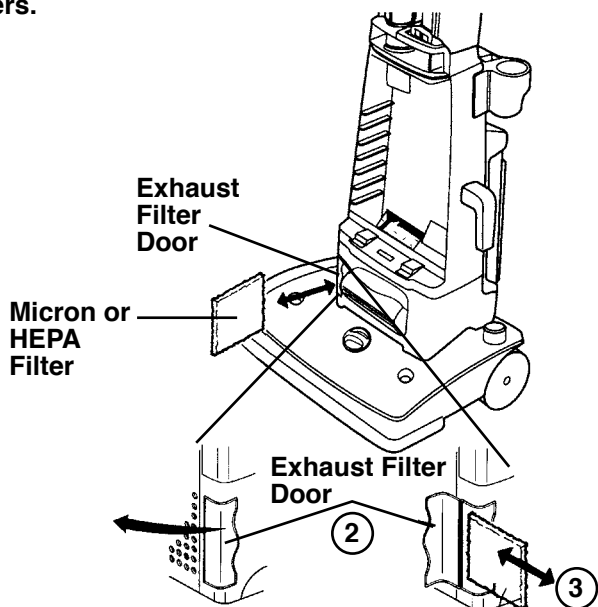

## THE EUREKA LIMITED WARRANTY

### What This Warranty Covers

Your Eureka cleaner is warranted to be free from all defects in material and workmanship in normal household use for a period of one year. The warranty is granted only to the original purchaser and members of his or her immediate household. The warranty is subject to the following provisions.

### What This Warranty Does Not Cover

- Parts of the cleaner that require replacement under normal use, such as disposable dust bags, filters, drive belts, light bulbs, and brush roll bristles, impellers and cleaning.
- Damages or malfunctions caused by negligence, abuse, or use not in accordance with the Owner's Guide.
- Defects or damages caused by unauthorized service or the use of other than Genuine Eureka parts.

### What The Eureka Company Will Do

The Eureka Company will, at its option, repair or replace a defective cleaner or cleaner part that is covered by this warranty. As a matter of warranty policy, the Eureka Company will not refund the consumer's purchase price.

### Warranty Registration

Please fill out and return the warranty registration card accompanying your cleaner.

### Obtaining Warranty Service

To obtain warranty service you must return the defective cleaner or cleaner part along with proof of purchase to any Eureka Authorized Warranty Station.

You will find the nearest location in the Yellow Pages, under "Vacuum Cleaners—Service and Repair." Be certain that the Warranty Station is "Eureka Authorized."

For the location of the nearest Eureka Authorized Warranty Station or for service information, telephone toll free:

**USA: 1-800-282-2886**  
**Mexico: 5670-6169**  
**Canada: 1-800-282-2886**

If you prefer, you can write to The Eureka Company, Service Division, 807 North Main Street, Bloomington, Illinois 61701, USA. In Canada write to The Eureka Company, 866 Langs Drive, Cambridge, Ontario N3H 2N7.

If it is necessary to ship the cleaner outside your community to obtain warranty repair, you must pay the shipping charges to the Eureka Authorized Warranty Station.

Return shipping charges will be paid by the Warranty Station. When returning parts for repair, please include the model, type, and serial number from the data plate on the cleaner.

### Further Limitations and Exclusions

Any warranty that may be implied in connection with your purchase or use of the cleaner, including any warranty of Merchantability or any warranty for Fitness For A Particular Purpose is limited to the duration of this warranty. Some states do not allow limitations on how long an implied warranty lasts, so the above limitations may not apply to you.

Your relief for the breach of this warranty is limited to the relief expressly provided above. In no event shall Eureka be liable for any consequential or incidental damages you may incur in connection with your purchase or use of the cleaner. Some states do not allow the exclusion or limitation of incidental or consequential damages, so the above limitation or exclusion may not apply to you.

This warranty gives you specific legal rights. You may also have other rights which vary by state.



### Questions & Answers about Genuine Eureka Products

**Q:** Why should I use only Genuine Eureka paper bags, belts, and parts in my Eureka vacuum cleaner?

**A:** Using Genuine Eureka Products, which are made to our exacting specifications and engineered with emphasis on quality, performance, and customer satisfaction, ensures the long life and cleaning efficiency of your vacuum cleaner. Overall, this saves you money and helps to keep your home clean.

**Q:** How can I be sure I am using only genuine Eureka products in my vacuum cleaner?

**A:** Typically, packaged products and paper bags can be identified by a "Genuine Eureka Product" symbol (see illustration above). For further identification assistance, you may call our toll-free number, 1-800-282-2886, for the location of a nearby Eureka Authorized Warranty Station.

**Q:** Are there any differences between "made to fit" or "imitation" and Genuine Eureka paper bags, belts, and parts?

**A:** Yes, there are some very important differences in materials, quality, and reliability. Many customers have mistakenly purchased "imitation" paper bags and parts while thinking they purchased genuine. Unfortunately, many of these customers discovered the differences after they experienced related difficulties.

**For Genuine Eureka Value, Accept No Imitations!**  
**THE EUREKA COMPANY**

Bloomington, Illinois 61701

Household Warranty  
abs 190

## HOW TO MAINTAIN (continued)

### How To Change Light Bulb (only for models with a headlight)

**NOTE:** Turn off the power switch and disconnect the electrical cord before changing light bulb.

1. Lower handle. Remove two screws from lens cover.
2. Pull lens cover from cleaner.
3. Pull light bulb and socket toward front.
4. Push light bulb into socket; turn to release.
5. Place new light bulb into socket; turn to secure.
6. Push light bulb and socket back so bulb will not touch lens cover.
7. Replace lens cover.
8. Secure with two screws.

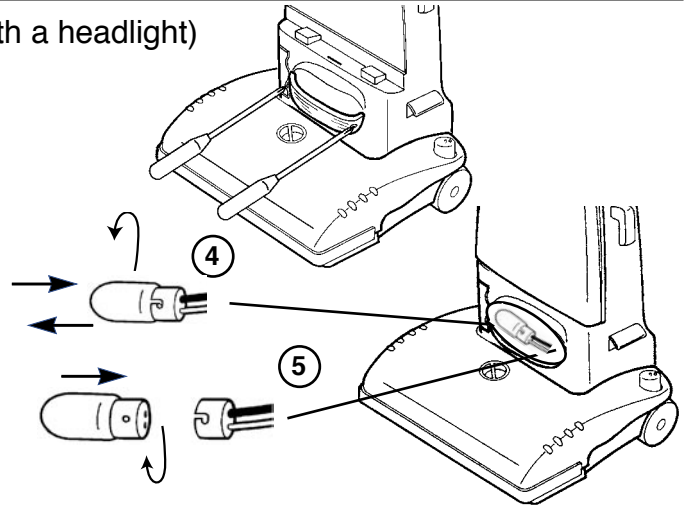

Use 15 watt replacement light bulb, part number 48815.

## Problem Solving **NOTE:** Turn off the switch and unplug electrical cord before servicing.

PROBLEM	CAUSE	SOLUTION
Motor will not start	<input type="radio"/> Electric Plug	<input type="checkbox"/> Push plug securely into outlet. Try another outlet. Check circuit breaker.
Motor suddenly stops	<input type="radio"/> Thermal Cut Off	<input type="checkbox"/> Refer to page 3 & 5.
Does not clean the carpet or floor.	<input type="radio"/> Disposable Dust Bag and Filter(s)	<input type="checkbox"/> Change the bag. <b>Hint:</b> If picking up fine dust, the bag may not look full, but a fine substance tends to reduce suction when it blocks the airflow through the paper bag and filter(s). Make sure the dust bag is installed properly. Make sure bag cover is installed properly.
	<input type="radio"/> Belt	<input type="checkbox"/> Replace a cut, loose or out of shape belt.
	<input type="radio"/> Brush Roll	<input type="checkbox"/> Clean hair and thread from bristles and end cap area. Replace brush roll if bristles are worn.
	<input type="radio"/> Hose	<input type="checkbox"/> Remove any clogs from the hose that restrict the airflow.
No suction at the end of the hose.	<input type="radio"/> Disposable Dust Bag	<input type="checkbox"/> Change the bag. <b>Hint:</b> If picking up fine dust, the bag may not look full, but a fine substance tends to reduce suction when it blocks the airflow through the paper bag.
	<input type="radio"/> Hose	<input type="checkbox"/> Remove any clogs from the hose that restrict the airflow. Check both ends of the hose. (See pages 13-14)
Headlight not working.	<input type="radio"/> Light Bulb	<input type="checkbox"/> Replace light bulb.
Noise from the brush roll area.	<input type="radio"/> Brush Roll	<input type="checkbox"/> Remove hood and clean debris from the brush roll area.
	<input type="radio"/> Belt	<input type="checkbox"/> Replace a cut, loose or out of shape belt.
Cleaner is hard to push.	<input type="radio"/> Cleaner Height Setting	<input type="checkbox"/> Turn adjustment knob to a higher position. <b>Hint:</b> Put handle in operating position. Tilt the cleaner back to raise the front wheels off floor. Then turn the knob.
	<input type="radio"/> Belt	<input type="checkbox"/> Replace a cut, loose and out of shape belt.
Brush roll will not turn.	<input type="radio"/> Belt	<input type="checkbox"/> Replace cut, loose or out of shape belt.
Burning smell.	<input type="radio"/> Belt	<input type="checkbox"/> Replace cut, loose or out of shape belt.
Cleaning height knob will not turn.	<input type="radio"/> Cleaner Height Setting	<input type="checkbox"/> <b>Hint:</b> Put handle in operating position. Tilt the cleaner back to raise the front wheels off floor. Then turn the knob.
Missing parts.	<input type="radio"/>	<input type="checkbox"/> Call 1-800-438-7352 between 8:00 a.m. and 4:45 p.m., central standard time, Monday through Friday. Know the model and serial numbers when you call.
Questions?	<input type="radio"/>	<input type="checkbox"/> Call 1-800-282-2886 8 a.m. to 7:30p.m., (CST), Monday - Friday and 10 a.m. to 6:30 p.m. (CST) Saturday. Know the model and serial numbers when you call.