

## Use and Care Guide



### Liquid Propane Gas Grill

Kenmore Model No. 415.16110800

**This Grill Is For  
Outdoor Use Only**



#### **WARNING**

- Read this manual before cooking on grill. Failure to follow all manufacturer's instructions could result in fire or explosion which could cause property damage, personal injury or death.
- Combustion by-products produced when using this product contain chemicals known to the State of California to cause cancer, birth defects, or other reproductive harm.

#### **CAUTION**

- Read and follow all Safety Statements, Assembly Instructions and Use & Care Directions before attempting to assemble and cook.
- Some parts may contain sharp edges, especially as noted in these instructions. Wear protective gloves if necessary.

- Parts
- Use and Care
- Assembly
- Troubleshooting
- Safety Rules

Assembly Questions?  
Call 1-800-241-7548

Parts Ordering:  
Call 1-800-4-MY-HOME®

To Installer/Assembler: Leave these instructions with consumer.

To Consumer: Keep this manual for future reference.

**Sears, Roebuck and Co., Hoffman Estates, IL 60179 U.S.A.**

 **DANGER** 

If you smell gas:

1. Shut off gas to the appliance.
2. Extinguish any open flame.
3. Open lid.
4. If odor continues, keep away from the appliance and immediately call your gas supplier or your fire department.

 **WARNING** 

**CALIFORNIA PROPOSITION 65**

1. Combustion by-products produced when using this product contain chemicals known to the State of California to cause cancer, birth defects, and other reproductive harm.
2. This product contains chemicals, including lead and lead compounds, known to the State of California to cause cancer, birth defects or other reproductive harm.

***Wash your hands after handling this product.***

**Installation Safety Precautions**

- Use grill, as purchased, only with LP (propane) gas and the regulator/valve assembly supplied. A conversion kit must be purchased for use with natural gas.
- Grill installation must conform with local codes, or in their absence of local codes, with either the *National Fuel Gas Code, ANSI Z223.1/ NFPA 54, Natural Gas and Propane Installation Code, CSA B149.1, or Propane Storage and Handling Code, B149.2, or the Standard for Recreational Vehicles, ANSI A 119.2/NFPA 1192, and CSA Z240 RV Series, Recreational Vehicle Code, as applicable.*
- All electrical accessories (such as rotisserie) must be electrically grounded in accordance with local codes, or *National Electrical Code, ANSI / NFPA 70 or Canadian Electrical Code, CSA C22.1.* Keep any electrical cords and/or fuel supply hoses away from any hot surfaces.
- This grill is safety certified for use in the United States and/or Canada only. Do not modify for use in any other location. Modification will result in a safety hazard.

**Safety Symbols**

The symbols and boxes shown below explain what each heading means. Read and follow all of the messages found throughout the manual.

 **DANGER** 

**DANGER:** Indicates an imminently hazardous situation which, if not avoided, will result in death or serious injury.

 **WARNING** 

**WARNING:** Indicates a potentially hazardous situation which, if not avoided, could result in death or serious injury.

 **CAUTION** 

**CAUTION:** Indicates a potentially hazardous situation or unsafe practice which, if not avoided, may result in minor or moderate injury.

 **WARNING** 

1. Do not store or use gasoline or other flammable liquids or vapors in the vicinity of this or any other appliance.
2. An LP cylinder not connected for use shall not be stored in the vicinity of this or any other appliance.

**Call Grill Service Center For Help And Parts**

If you have questions or need assistance during assembly, please call **1-800-241-7548**. You will be speaking to a representative of the grill manufacturer and not a Sears employee. To order new parts call Sears at **1-800-4-MY-HOME®**.

**Product Record**

**IMPORTANT:** Fill out the product record information below.

Model Number \_\_\_\_\_

Serial Number \_\_\_\_\_  
See rating label on grill for serial number.

Date Purchased \_\_\_\_\_

 **CAUTION** 

**For residential use only. Do not use for commercial cooking.**

## TABLE OF CONTENTS

For Your Safety . . . . .	2
Grill Service Center. . . . .	2
Product Record Information . . . . .	2
Safety Symbols. . . . .	2
Installation Safety Precautions . . . . .	2
Kenmore Grill Warranty . . . . .	3
Use and Care . . . . .	4-10
Parts List . . . . .	11
Parts Diagram . . . . .	12
Assembly . . . . .	13-24
Troubleshooting . . . . .	25-27

### Repair Protection Agreements

*Congratulations on making a smart purchase.* Your new Kenmore® product is designed and manufactured for years of dependable operation. But like all products, it may require repair from time to time. That's when having a Repair Protection Agreement can save you money and aggravation.

*Purchase a Repair Protection Agreement now and protect yourself from unexpected hassle and expense.*

Here's what the Repair Protection Agreement\* includes:

- ✓ **Expert service** by our 10,000 professional repair specialists
- ✓ **Unlimited service and no charge** for parts and labor on all covered repairs
- ✓ **Product replacement** up to \$1500 if your covered product can't be fixed
- ✓ **Discount of 10%** from regular price of service and related installed parts not covered by the agreement; also, 10% off regular price of preventive maintenance check
- ✓ **Fast help by phone** – we call it Rapid Resolution – phone support from a Sears representative. Think of us as a “talking owner’s manual.”

Once you purchase the Repair Protection Agreement, a simple phone call is all that it takes for you to schedule service. You can call anytime day or night, or schedule a service appointment online.

The Repair Protection Agreement is a risk-free purchase. If you cancel for any reason during the product warranty period, we will provide a full refund. Or, a prorated refund anytime after the product warranty period expires. Purchase your Repair Protection Agreement today!

**Some limitations and exclusions apply.**

**For prices and additional information call 1-800-827-6655.**

### Sears Installation Service

*For Sears professional installation* of home appliances, garage door openers, water heaters, and other major home items, in the U.S.A. call **1-800-4-MY-HOME®**

## WARRANTY

### KENMORE GRILL WARRANTY

#### One Year Full Warranty on Kenmore Grill

If this grill fails due to a defect in material or workmanship within one year from the date of purchase, call 1-800-4-MY HOME® to arrange for free repair (or replacement if repair proves impossible).

Any burner that rusts through during the warranty period will be replaced free of charge.

This warranty excludes ignitor batteries and grill part paint loss, discoloration or rusting, which are either expendable parts that can wear out from normal use within the warranty period, or are conditions that can be the result of normal use, accident or improper maintenance.

This warranty is void if this grill is used for commercial or rental purposes.

This warranty applies only if this grill is used in the United States.

This warranty gives you specific legal rights, and you may have other rights which vary from state to state.

**Sears, Roebuck and Co., Hoffman Estates, IL 60179**

## USE AND CARE



# DANGER



- **NEVER** store a spare LP tank under or near grill or in enclosed areas

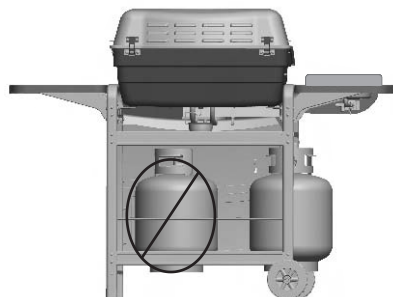

- Never fill the cylinder beyond 80% full.
- An overfilled or improperly stored tank is a hazard due to possible gas release from the safety relief valve.
- If you see, smell or hear escaping gas, immediately get away from the LP tank/grill and call your fire department.
- If the above is not followed exactly, a fire causing death or serious injury may occur.

### LP Tank Removal, Transport And Storage

- Turn OFF all control knobs and LP tank valve. Turn coupling nut counterclockwise by hand only - do not use tools to disconnect. Lift LP tank wire upward off of LP tank collar, then lift LP tank up and off of support bracket. Install safety cap onto LP tank valve. Always use cap and strap supplied with valve. **Failure to use safety cap as directed may result in serious personal injury and/or property damage.**

LP Tank Valve

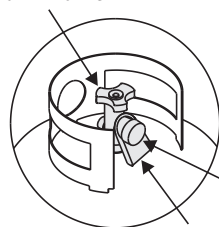

Safety Cap

Retainer Strap

- A disconnected LP tank in storage or being transported must have a safety cap installed (as shown). Do not store an LP tank in enclosed spaces such as a carport, garage, porch, covered patio or other building. Never leave an LP tank inside a vehicle which may become overheated by the sun.
- Do not store an LP tank in an area where children play.

### LP Cylinder

- **The LP cylinder used with your grill must meet the following requirements:**
- Use LP cylinders only with these required measurements: 12" (30.5cm) (diameter) x 18" (45.7 cm) (tall) with 20 lb. (9 kg.) capacity maximum.
- LP cylinders must be constructed and marked in accordance with specifications for LP cylinders of the U.S. Department of Transportation (DOT) or for Canada, CAN/CSA-B339, cylinders, spheres and tubes for transportation of dangerous goods. Transport Canada (TC). See LP cylinder collar for marking.
- LP cylinder valve must have:
  - Type 1 outlet compatible with regulator or grill.
  - Safety relief valve.
  - UL listed Overfill Protection Device (OPD). This OPD safety feature is identified by a unique triangular hand wheel. **Use only LP cylinders equipped with this type of valve.**
- LP cylinder must be arranged for vapor withdrawal and include collar to protect LP cylinder valve. Always keep LP cylinders in upright position during use, transit or storage.

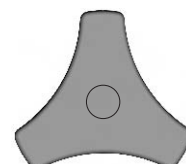

OPD Hand Wheel



LP cylinder in upright position for vapor withdrawal

### LP (Liquefied Petroleum Gas)

- LP gas is nontoxic, odorless and colorless when produced. **For Your Safety**, LP gas has been given an odor (similar to rotten cabbage) so that it can be smelled.
- LP gas is highly flammable and may ignite unexpectedly when mixed with air.

### LP Cylinder Filling

- Use only licensed and experienced dealers.
- LP dealer **must purge new cylinder** before filling.
- Dealer should **NEVER** fill LP cylinder more than 80% of LP cylinder volume. Volume of propane in cylinder will vary by temperature.
- A frosty regulator indicates gas overfill. Immediately close LP cylinder valve and call local LP gas dealer for assistance.
- Do not release liquid propane (LP) gas into the atmosphere. This is a hazardous practice.
- To remove gas from LP cylinder, contact an LP dealer or call a local fire department for assistance. Check the telephone directory under "Gas Companies" for nearest certified LP dealers.

## LP Tank Exchange

- Many retailers that sell grills offer you the option of replacing your empty LP tank through an exchange service. Use only those reputable exchange companies that inspect, precision fill, test and certify their cylinders. **Exchange your tank only for an OPD safety feature-equipped tank as described in the "LP Tank" section of this manual.**
- Always keep new and exchanged LP tanks in upright position during use, transit or storage.
- **Leak test new and exchanged LP tanks BEFORE connecting to grill.**

## LP Tank Leak Test

### For your safety

- Leak test must be repeated each time LP tank is exchanged or refilled.
- Do not smoke during leak test.
- Do not use an open flame to check for gas leaks.
- Grill must be leak tested outdoors in a well-ventilated area, away from ignition sources such as gas fired or electrical appliances. During leak test, keep grill away from open flames or sparks.
- Use a clean paintbrush and a 50/50 mild soap and water solution. Brush soapy solution onto areas indicated by arrows in figure below. Leaks are indicated by growing bubbles.

	<h1>WARNING</h1>	
<p>If "growing" bubbles appear do not use or move the LP tank. Contact an LP gas supplier or your fire department!</p>		

- ▲ **Do not use household cleaning agents.** Damage to gas train components can result.

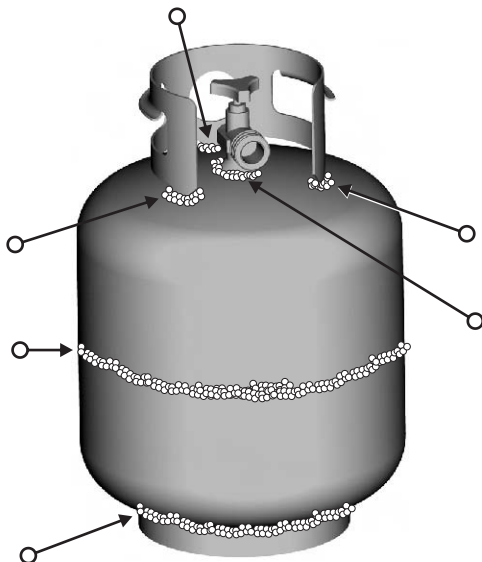

## Connecting Regulator To The LP Tank

1. LP tank must be properly secured onto grill. (Refer to assembly section.)
2. Turn all control knobs to the OFF position.
3. Turn LP tank OFF by turning OPD hand wheel clockwise to a full stop.
4. Remove the protective cap from LP tank valve. Always use cap and strap supplied with valve.

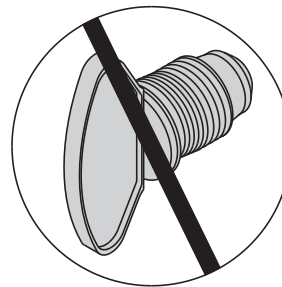
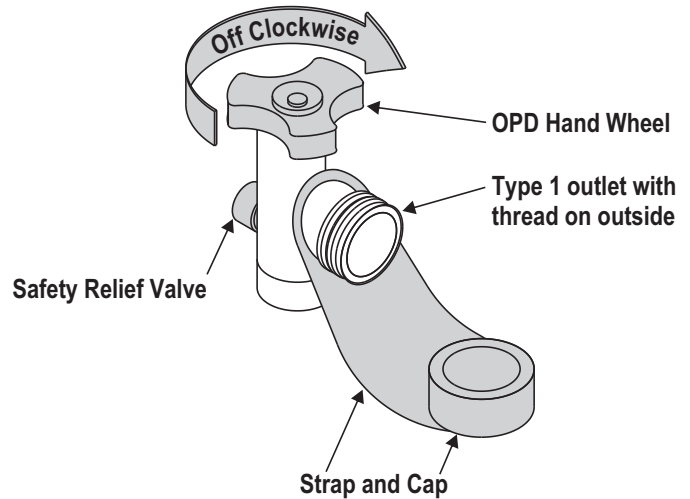

**Do not use a POL transport plug (plastic part with external threads)! It will defeat the safety feature of the valve.**

5. Hold regulator and insert nipple into LP tank valve. Hand-tighten the coupling nut, holding regulator in a straight line with LP tank valve so as not to cross-thread the connection.

**Nipple has to be centered into the LP tank valve.**

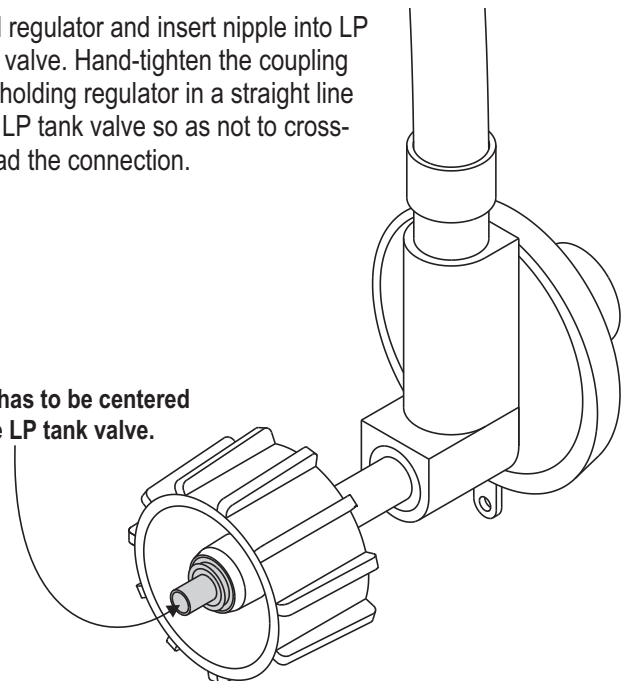



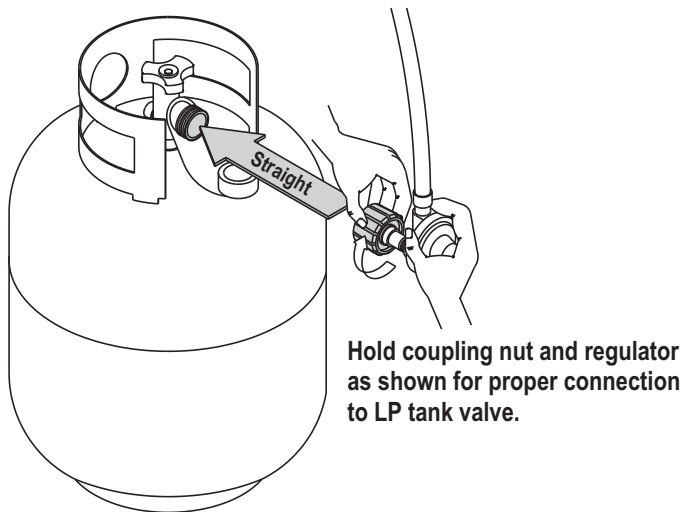

6. Turn the coupling nut clockwise and tighten to a full stop. The regulator will seal on the back-check feature in the LP tank valve, resulting in some resistance. **An additional one-half to three-quarters turn is required to complete the connection. Tighten by hand only – do not use tools.**

**NOTE:**

If you cannot complete the connection, disconnect regulator and repeat steps 5 and 6. If you are still unable to complete the connection, **do not use this regulator!**

	<b>DANGER</b>	
<ul style="list-style-type: none"> <li>Do not insert any tool or foreign object into the valve outlet or safety relief valve. You may damage the valve and cause a leak. Leaking propane may result in explosion, fire, severe personal injury, or death.</li> </ul>		

	<b>WARNING</b>	
<ul style="list-style-type: none"> <li>Outdoor gas appliance is not intended to be installed in or on a boat.</li> <li>Outdoor gas appliance is not intended to be installed in or on an RV.</li> <li>Never attempt to attach this grill to the self-contained LP gas system of a camper trailer or motor home.</li> <li>Do not use grill until leak-tested.</li> <li>If a leak is detected at any time, STOP and call the fire department.</li> <li>If you cannot stop a gas leak, <i>immediately</i> close LP cylinder valve and call LP gas supplier or your fire department!</li> </ul>		

**Leak Testing Valves, Hose and Regulator**

1. Turn all grill control knobs to OFF.
2. Be sure regulator is tightly connected to LP tank.
3. Completely open LP tank valve by turning OPD hand wheel counterclockwise. If you hear a *rushing sound*, turn gas off immediately. There is a major leak at the connection. **Correct before proceeding** by calling Sears for replacement parts at 1-800-4-MY-HOME®.
4. Brush soapy solution onto areas where bubbles are shown in picture below:

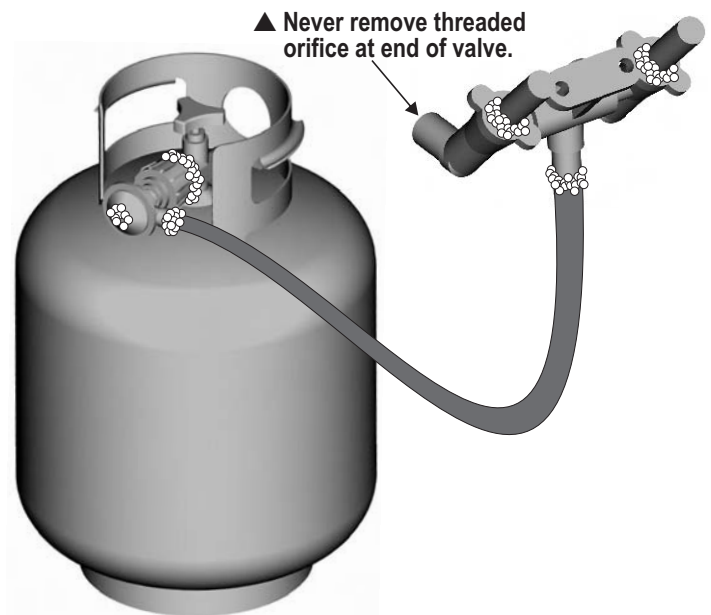

5. If “growing” bubbles appear, there is a leak. Close LP tank valve immediately and retighten connections. **If leaks cannot be stopped do not try to repair.** Call Sears for replacement parts at 1-800-4-MY-HOME®.
6. Always close LP tank valve after performing leak test by turning hand wheel clockwise.



## WARNING



### For Safe Use Of Your Grill And To Avoid Serious Injury:

- Do not let children operate or play near grill.
- Keep grill area clear and free from materials that burn.
- Do not block holes in bottom or back of grill.
- Check burner flames regularly.
- Use grill only in well-ventilated space. NEVER use in enclosed space such as carport, garage, porch, covered patio, or under an overhead structure of any kind.
- Do not use charcoal or ceramic briquets in a gas grill. (*Unless briquets are supplied with your grill.*)
- **Use grill at least 3 ft. from any wall or surface.** Maintain 10 ft. clearance to objects that can catch fire or sources of ignition such as pilot lights on water heaters, live electrical appliances, etc.

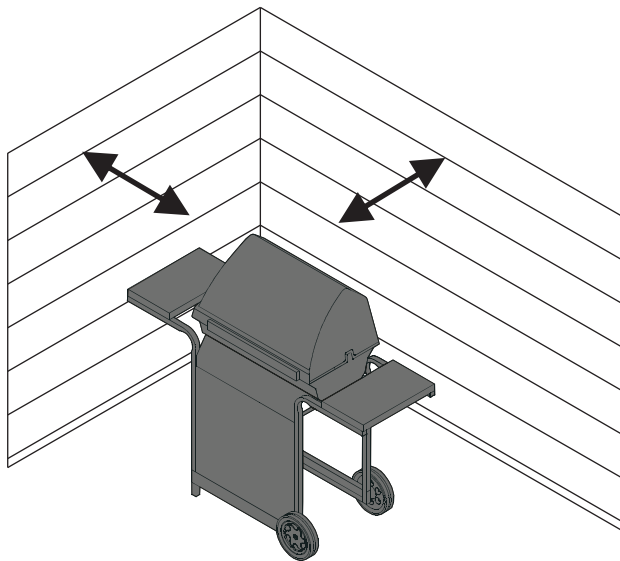

#### • Apartment Dwellers:

Check with management to learn the requirements and fire codes for using an LP gas grill in your apartment complex. If allowed, use outside on the ground floor with a three (3) foot clearance from walls or rails. Do not use on or under balconies.

- **NEVER attempt to light burner with lid closed. A buildup of non-ignited gas inside a closed grill is hazardous.**
- **Never operate grill with LP tank out of correct position specified in assembly instructions.**
- **Always close LP tank valve and remove coupling nut before moving LP tank from specified operation position.**

### Safety Tips

- ▲ Before opening LP cylinder valve, check the coupling nut for tightness.
- ▲ When grill is not in use, turn off all control knobs and LP cylinder valve.
- ▲ Never move grill while in operation or still hot.
- ▲ Use long-handled barbecue utensils and oven mitts to avoid burns and splatters.
- ▲ Maximum load for sideburner and side shelf is 10 lbs.
- ▲ The grease tray **must** be inserted into grill and emptied after each use. Do not remove grease tray until grill has completely cooled.
- ▲ Clean grill often, preferably after each cookout. If a bristle brush is used to clean any of the grill cooking surfaces, ensure no loose bristles remain on cooking surfaces prior to grilling. It is not recommended to clean cooking surfaces while grill is hot.
- ▲ If you notice grease or other hot material dripping from grill onto valve, hose or regulator, turn off gas supply at once. Determine the cause, correct it, then clean and inspect valve, hose and regulator before continuing. Perform a leak test.
- ▲ Keep ventilation openings in cylinder enclosure (grill cart) free and clear of debris.
- ▲ Do not store objects or materials inside the grill cart enclosure that would block the flow of combustion air to the underside of either the control panel or the firebox bowl.
- ▲ The regulator may make a humming or whistling noise during operation. This will not affect safety or use of grill.
- ▲ If you have a grill problem see the "Troubleshooting Section".
- ▲ If the regulator frosts, turn off grill and LP cylinder valve immediately. This indicates a problem with the cylinder and it should not be used on any product. Return to supplier!



## CAUTION





- **Putting out grease fires by closing the lid is not possible. Grills are well ventilated for safety reasons.**
- **Do not use water on a grease fire. Personal injury may result. If a grease fire develops, turn knobs and LP cylinder off.**
- **Do not leave grill unattended while preheating or burning off food residue on HI. If grill has not been regularly cleaned, a grease fire can occur that may damage the product.**

## Main burner Ignitor Lighting

▲ Do not lean over grill while lighting.

1. Open lid during lighting.
2. Turn ON valve from source or tank.
3. Push and turn Ignition Burner control knob to ➤ HI and immediately press and hold Electronic Ignition button.
4. If ignition does NOT occur in 5 seconds, turn Left Burner control knob OFF, wait 5 minutes for gas to clear and repeat the lighting procedure.
5. To Light Other Burners turn control knob to HI.  
If ignitor does not work, follow match lighting instructions.  
After Lighting: Turn knobs to HI position for 15 minutes to pre-heat grill. Then turn knob to desired setting for cooking.

	<h1>CAUTION</h1>	
<p>If burner does not light, turn knobs to OFF, wait 5 minutes, and try again. Always close valve during the 5 minute waiting period. If the burner does not ignite with the valve open, gas will continue to flow out of the burner and could accidentally ignite with risk of injury.</p>		

## Match-Lighting

▲ Do not lean over grill while lighting.

1. Open lid during lighting.
2. Place match into match holder (hanging from side of cart).
3. Push in and turn left knob to ➤ HI position. Be sure burner lights and stays lit.
4. Light right burner by pushing knob in and turning to ➤ HI position.

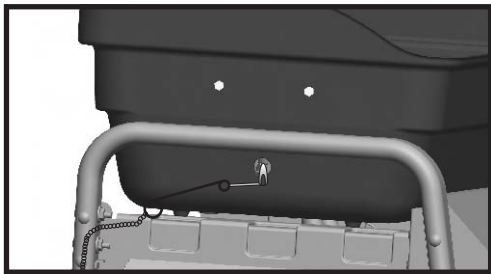

## Sideburner Ignitor Lighting

▲ Do not lean over grill while lighting.

1. Open lid or cover for Side Burner during lighting.
2. Turn ON valve from source or tank.
3. Push and turn Side Burner control knob to ➤ HI and immediately press and hold Electronic Ignition button.
4. If ignition does NOT occur in 5 seconds, turn Side Burner control knob OFF, wait 5 minutes for gas to clear, and repeat the lighting instructions.  
If ignitor does not work, follow match lighting instructions.  
After Lighting: Turn knobs to HI position for warm-up.

## Sideburner Match Lighting

1. Open top cover. Turn on gas at LP tank.
2. Hold lit match to any port on the burner. Push in and turn sideburner knob to ➤ HIGH. Be sure burner lights and stays lit.

## Before Your First Cookout

- Light burners, check to make sure they are lit, close the lid and warm up grill on HIGH for 15 minutes. This curing of paint and parts will produce an odor only on first lighting.

## Burner Flame Check

- Light burner, rotate knobs from HIGH to LOW. You should see a smaller flame in LOW position than seen on HIGH. Always check flame prior to each use. If only low flame is seen refer to "Sudden drop or low flame" in the *Troubleshooting Section*.

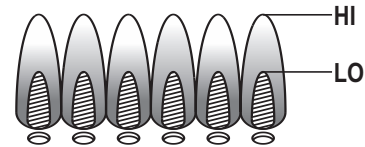

## Hose Check

- Before each use, check to see if hoses are cut, worn or kinked. Replace damaged hoses before using grill. Use only valve/hose/regulator specified in the Parts List.





## Turning Grill Off

- Turn all knobs to **OFF** position. Turn LP tank off by turning OPD hand wheel clockwise to a full stop.

## Ignitor Check

- **Turn gas off at LP tank.** Press and hold ignitor button. "Click" should be heard and spark seen each time between collector box or burner and electrodes. See "*Troubleshooting*" if no click or spark.

## Valve Check

- **Important: Make sure gas is off at LP tank before checking valves.** Knobs lock in **OFF** position. To check valves, first push in knobs and release, knobs should spring back. If knobs do not spring back, replace valve assembly before using grill. Turn knobs to **LO** position then turn back to **OFF** position. Valves should turn smoothly.

## General Grill Cleaning

- Keep the outside of your grill looking new by cleaning it once a month with warm soap and water or a non-abrasive cleaner. If you don't have a grill cover, wipe off dust and grime before starting your grill.
- Coating the cooking grids with spray-on cooking oil will keep the food from sticking and make clean up easier. After cooking, scrape the grates with a long handled, brass wire bristle brush.
- Check inside the grill bottom for grease build up and clean often, especially after cooking fatty meat.
- Do not mistake brown or black accumulation of grease and smoke for paint. Apply a strong solution of detergent and water or use a grill cleaner with scrub brush on insides of grill lid and bottom. Rinse and allow to completely air dry. **Do not apply a caustic grill/oven cleaner to painted surfaces.**
- **Plated wire grates:** Wash grates with concentrated grill cleaner or use soap and water solution. Dry thoroughly and store indoors between cookouts.
- **Plastic parts:** Wash with warm soapy water and wipe dry.
  - ▲ Do not use citrisol, abrasive cleaners, degreasers or a concentrated grill cleaner on plastic parts. Damage to and failure of parts can result.
- **Porcelain grates:** Because of glass-like composition, most residue can be wiped away with baking soda/water solution or specially formulated cleaner. Use non-abrasive scouring powder for stubborn stains.
- **Painted surfaces:** Wash with mild detergent or nonabrasive cleaner and warm soapy water. Wipe dry with a soft nonabrasive cloth.
- **Stainless steel surfaces:** To maintain your grill's high quality appearance, wash with mild detergent and warm soapy water and wipe dry with a soft cloth after each use. Baked-on grease deposits may require the use of an abrasive plastic cleaning pad. Use only in direction of brushed finish to avoid damage. Do not use abrasive pad on areas with graphics.
- **Cooking surfaces:** If a bristle brush is used to clean any of the grill cooking surfaces, ensure no loose bristles remain on cooking surfaces prior to grilling. It is not recommended to clean cooking surfaces while grill is hot.



## SPIDER ALERT!

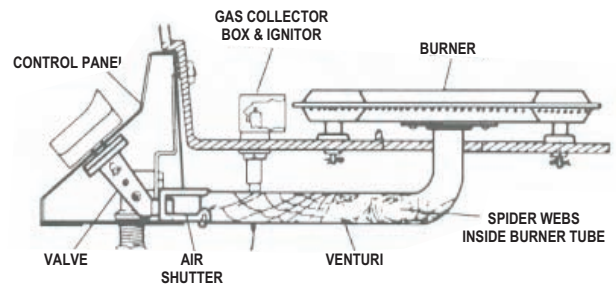

*If you notice that your grill is getting hard to light or that the flame isn't as strong as it should be, take the time to check and clean the burner tube.*

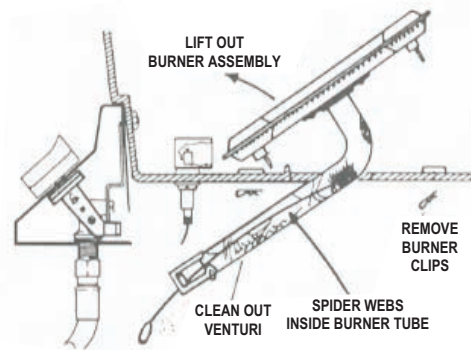

In some areas of the country, spiders or small insects have been known to create "flashback" problems. The spiders spin webs, build nests and lay eggs in the grill's venturi tube(s) obstructing the flow of gas to the burner. The backed-up gas can ignite in the burner tube behind the control panel. This is known as a flashback and it can damage your grill and even cause injury.

To prevent flashbacks and ensure good performance the burner and venturi assembly should be removed from the grill and cleaned before use whenever the grill has been idle for an extended period.

## Cleaning the Burner Assembly

Follow these instructions to clean and/or replace parts of burner assembly or if you have trouble igniting grill.

1. Turn gas off at control knobs and LP cylinder.
2. Remove cooking grate and vaporiser bar.
3. Under grill remove grease cup, disconnect ignitor wire and clips from burner. To remove clips pull down on large end of clip attached to the valve, turn away from valve, rotate upward and remove small end of clip from burner tube (A).
4. Inside grill remove burner assembly (B), clean ceramic portion of electrode with rubbing alcohol and a swab.
5. Clean outside of burner with soap and water. Lay burner upside down on flat surface, insert garden hose to force water through tubes. Make sure water comes out of all burner holes. Open clogged holes with a thin wire. Shake out excess water and examine holes. Due to normal wear and corrosion some holes may become enlarged. If any large cracks or holes are found replace burner.
6. If grill is to be stored, coat burner lightly with cooking oil. Wrap in protective cover to keep insects out.
7. If not storing grill after cleaning, replace burner into grill bottom.
8. To reattach clips hold large curved end away from burner tube, insert small curved end into hole under burner tubes, turn clip towards valve, snap into place.

**VERY IMPORTANT: Burner tubes must reengage valve openings. See illustration (A).**

9. Reattach ignitor wire to electrode.
10. Reposition vaporiser bar and cooking grate. Reattach clean grease cup to grease clip.
11. Before cooking again on grill, perform a "Leak Test" and "Burner Flame Check".

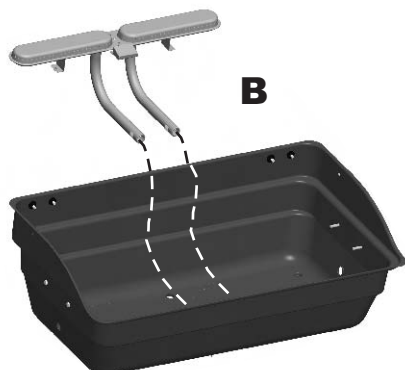
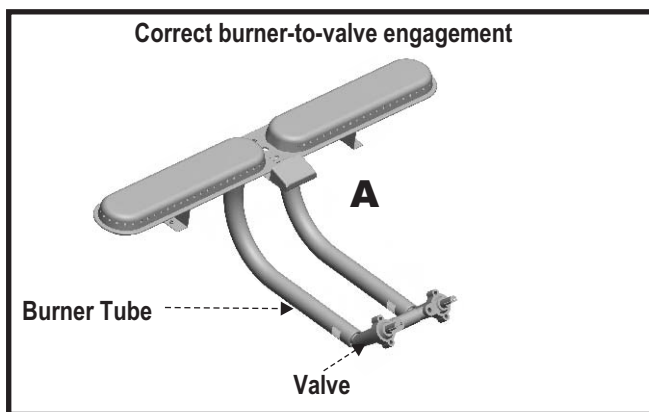

## Storing Your Grill

- Clean cooking grates.
- Store in dry location.
- When LP tank is connected to grill, store outdoors in well-ventilated space and out of reach of children.
- Cover grill if stored outdoors.
- Store grill indoors ONLY if LP tank is turned off and disconnected, removed from grill and stored outdoors.
- When removing grill from storage follow "Cleaning Burner Assembly" instructions before starting grill.

## Food Safety

Food safety is a very important part of enjoying the outdoor cooking experience. To keep food safe from harmful bacteria, follow these four basic steps:

**Clean:** Wash hands, utensils, and surfaces with hot soapy water before and after handling raw meat and poultry.

**Separate:** Separate raw meats and poultry from ready-to-eat foods to avoid cross contamination. Use a clean platter and utensils when removing cooked foods.

**Cook:** Cook meat and poultry thoroughly to kill bacteria. Use a thermometer to ensure proper internal food temperatures.

**Chill:** Refrigerate prepared foods and leftovers promptly.

**For more information call: USDA Meat and Poultry Hotline at 1-800-535-4555 (In Washington, DC (202) 720-3333, 10:00 am-4:00 pm EST).**

## How To Tell If Meat Is Grilled Thoroughly

- Meat and poultry cooked on a grill often browns very fast on the outside. Use a meat thermometer to be sure food has reached a safe internal temperature, and cut into food to check for visual signs of doneness.
- Whole poultry should reach 180° F; breasts, 170° F. Juices should run clear and flesh should not be pink.
- Hamburgers made of any ground meat or poultry should reach 160° F, and be brown in the middle with no pink juices. Beef, veal and lamb steaks, roasts and chops can be cooked to 145° F. All cuts of pork should reach 160° F.
- NEVER partially grill meat or poultry and finish cooking later. Cook food completely to destroy harmful bacteria.
- When reheating takeout foods or fully cooked meats like hot dogs, grill to 165° F, or until steaming hot.

## PARTS LIST – Modelo No. 415.16110800

Key	Qty	Description	Part #	Key	Qty	Description	Part #
1	2	Upper Leg	80010075	44	1	Grate, Side Burner	80009728
2	1	Leg, Left Front	80010080	45	1	Sideburner Clip	80015912
3	1	Leg, Left Back	80010079	46	1	Wing Nut	80015912
4	1	Leg, Right Front	80010077	47	3	#8X3/8" Self-Tap Screw	80015912
5	1	Leg Right Back	80010078	48	2	Lower Hinge	80012696
6	1	Side Brace	80010076	49	2	Upper Hinge	80012695
7	2	Support Bracket	80010082	50	1	Lid Handle	80012224
8	1	Match Holder	80004320	51	1	Top Lid	80015577
9	2	Leg Extender	80009820	52	4	6.5mm ID, 18mm OD Fiber Washer	80015912
10	4	Hinge Pin	80015912	53	1	Heat Diffuser	80009181
11	5	Hitch Pin	80015912	54	1	Cooking Grate	80013209
12	12	#10-24x1-1/4" Screw	80015912	55	1	Swing Away	80009166
13	46	#10-24 Flange Nut	80015912	56	1	Grease Cup	80000270
14	1	Tank Exclusion Wire	80009896	57	1	Clip, Grease Cup	80000271
15	1	Upper Front Panel	80012240	58	1	Logo Plate	80010544
16	1	Lower Front Panel	80012241	59	1	Heat Shield, Firebox	80010068
17	16	#10-24x2" Screw	80015912	60	2	#8-32x3/8" Screw	80015912
18	2	Back Brace	80012236	61	4	5mm ID, 9mm OD Fiber Washer	80015912
19	2	Wheel	80010191	62	1	Lid, Sideburner	80015899
20	1	Axle Rod	80010088	63	1	Condiment Basket	80010102
21	1	Wheel Bushing	80015912	1	1	Assembly Instructions (English)	80015569
22	1	Control Panel	80015583	1	1	Assembly Instructions (Spanish)	80015570
23	1	Fire Box Support, Left	80010083	1	1	Hardware Pack	80015912
24	1	Fire Box Support, Right	80010084	1	1	Wheel Bushing	
25	1	Hose/Valve/Regulator	80015582	1	1	Sideburner Clip	
26	1	EI Module	80014484	4	4	Hinge Pin	
27	32	#10-24X1/2" Screw	80015912	5	5	Hitch Pin	
28	1	Heat Shield	80012244	1	1	Wing Screw	
29	1	Tank Retainer	80009014	1	1	Wing Nut	
30	1	Wing Screw	80015912	12	12	#10-24X1-1/4" Screw	
31	1	Fire Box	80015575	32	32	#10-24X1/2" Screw	
32	1	Burner Assembly	80012232	46	46	#10-24, Flange Nut	
33	3	Control Knobs	80014405	2	2	#8-32x3/8" Screw	
34	22	5mm ID, 15mm OD Fiber Washer	80015912	3	3	#8X3/8" Self-Tap Screw	
35	1	Side Shelf (Without Hole)	80010072	16	16	#10-24X2" Screw	
36	1	Side Shelf (With Hole/Fascia)	80015581	4	4	1/4"-20x1-1/4" Screw	
37	2	Mounting Side Shelf (RF/LB)	80010073	4	4	1/4"-20x1/2" Screw	
38	2	Mounting Side Shelf (LF/RB)	80010074	4	4	1/4"-20 Flange Nut	
39	4	1/4"-20x1-1/4" Screw	80015912	22	22	5mm ID, 15mm OD Fiber Washer	
40	4	1/4"-20x1/2" Screw	80015912	4	4	5mm ID, 9mm OD Fiber Washer	
41	4	1/4"-20 Flange Nut	80015912	4	4	6.5mm ID, 18mm OD Fiber Washer	
42	1	Side Burner Pan	80006246				
43	1	Side Burner Assembly	80015910	2	2	#10-24x3/4" Screws	
				6	6	5.5mm ID, 19mm OD Fiber Washer	
				2	2	5.5mm ID, 19mm OD Flat Washer	

# PARTS DIAGRAM – Modelo No. 415.16110800

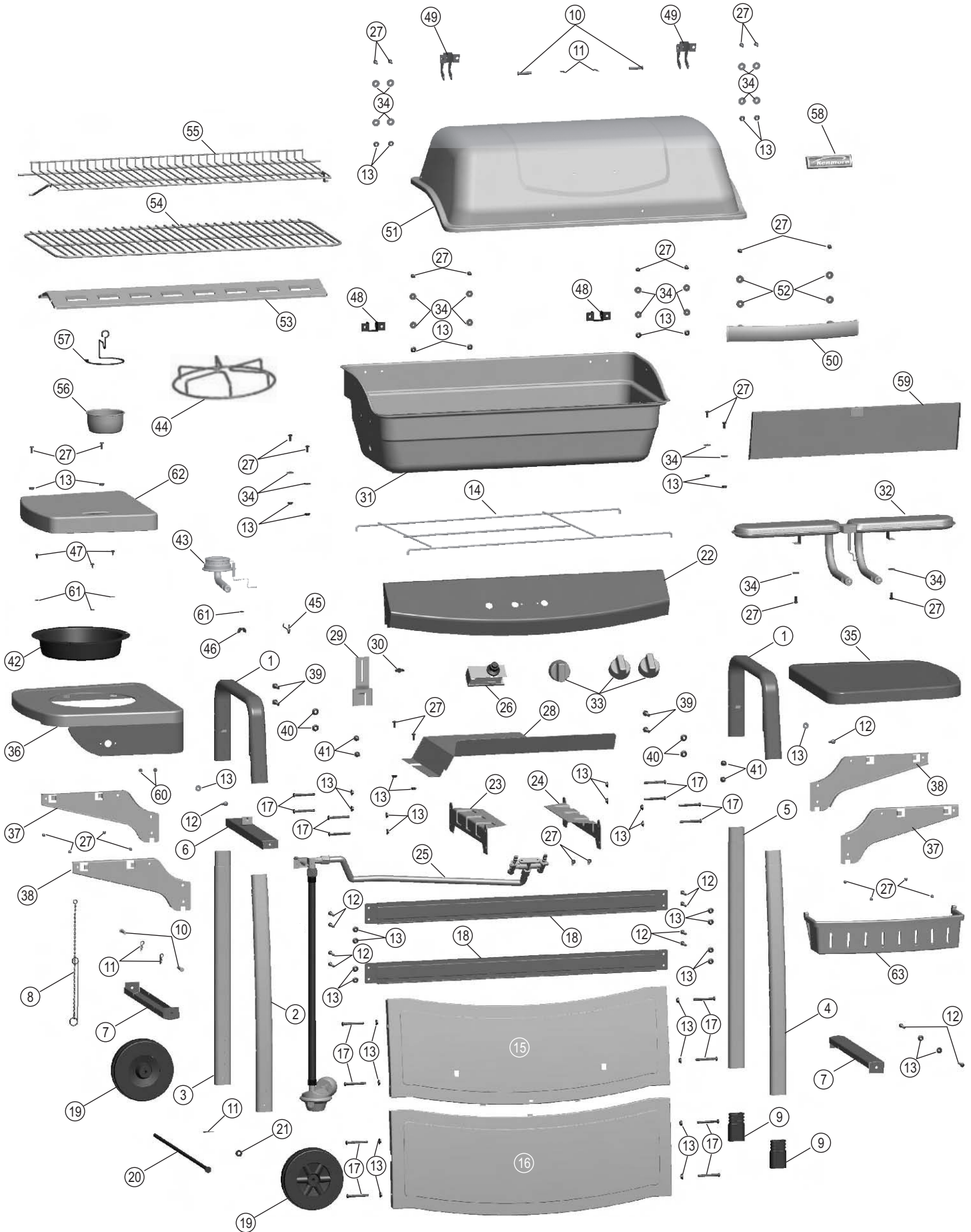



## ASSEMBLY – Modelo No. 415.16110800

# 1

### Left Leg

- Place one upper leg as shown . NOTE: Left front and left back legs do not have leg extenders. In front, attach upper leg, side brace and left front leg (curve) with **#10-24x1-1/4" screw** and **#10-24 flange nut**. In back, attach upper leg, side brace and left back leg (straight) with **#10-24x1-1/4" screw** and **#10-24 flange nut**. **Do not tighten.**
- Attach support bracket in second hole from bottom of leg with hinge pins and hitch pins **(A)**.

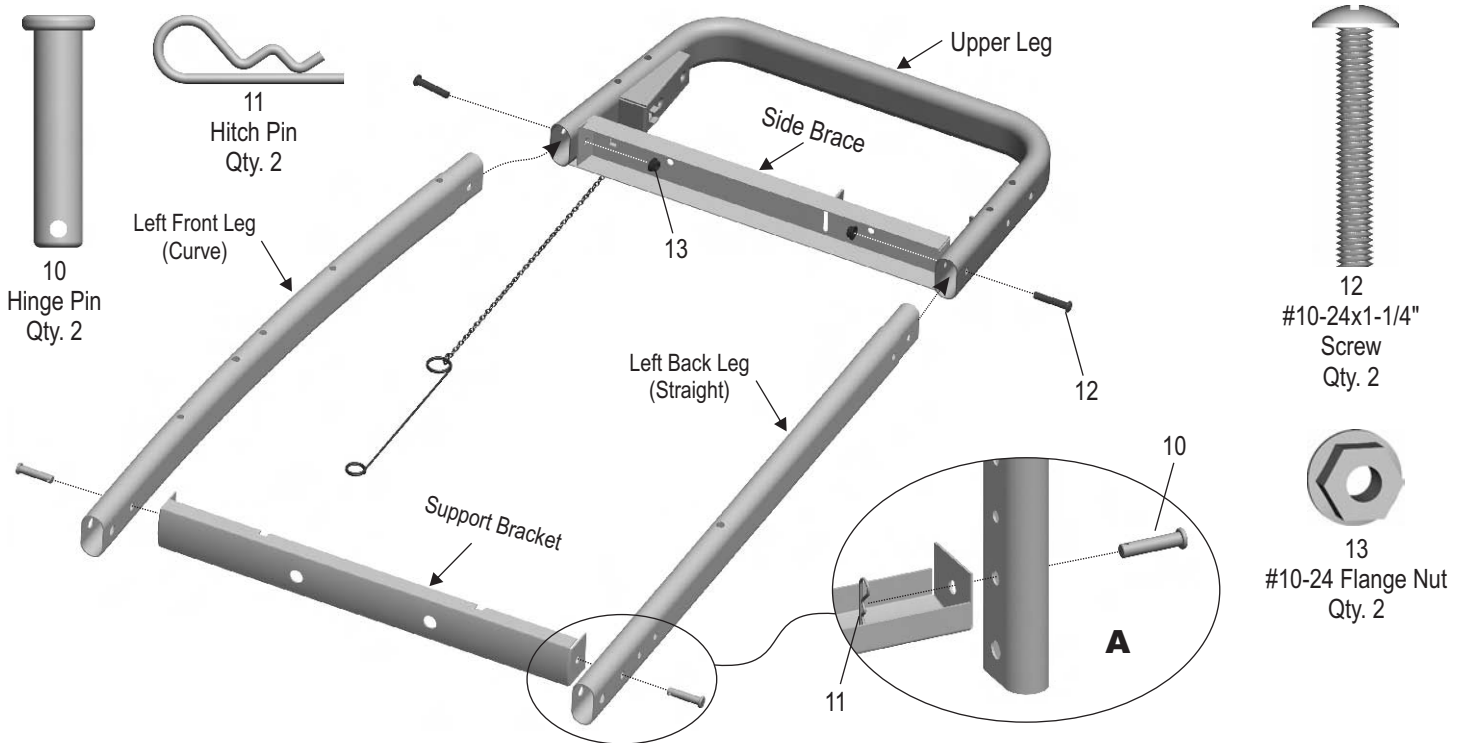

# 2

### Right Leg

- Place other upper leg as shown. Attach upper leg and right front leg (curve) with **#10-24x1-1/4" screw** and **#10-24 flange nut**. Then attach upper leg and right back leg (straight) with **#10-24x1-1/4" screw** and **#10-24 flange nut**. **Do not tighten.**
- Attach support bracket with **#10-24x1-1/4" screws** and **#10-24 flange nuts**.

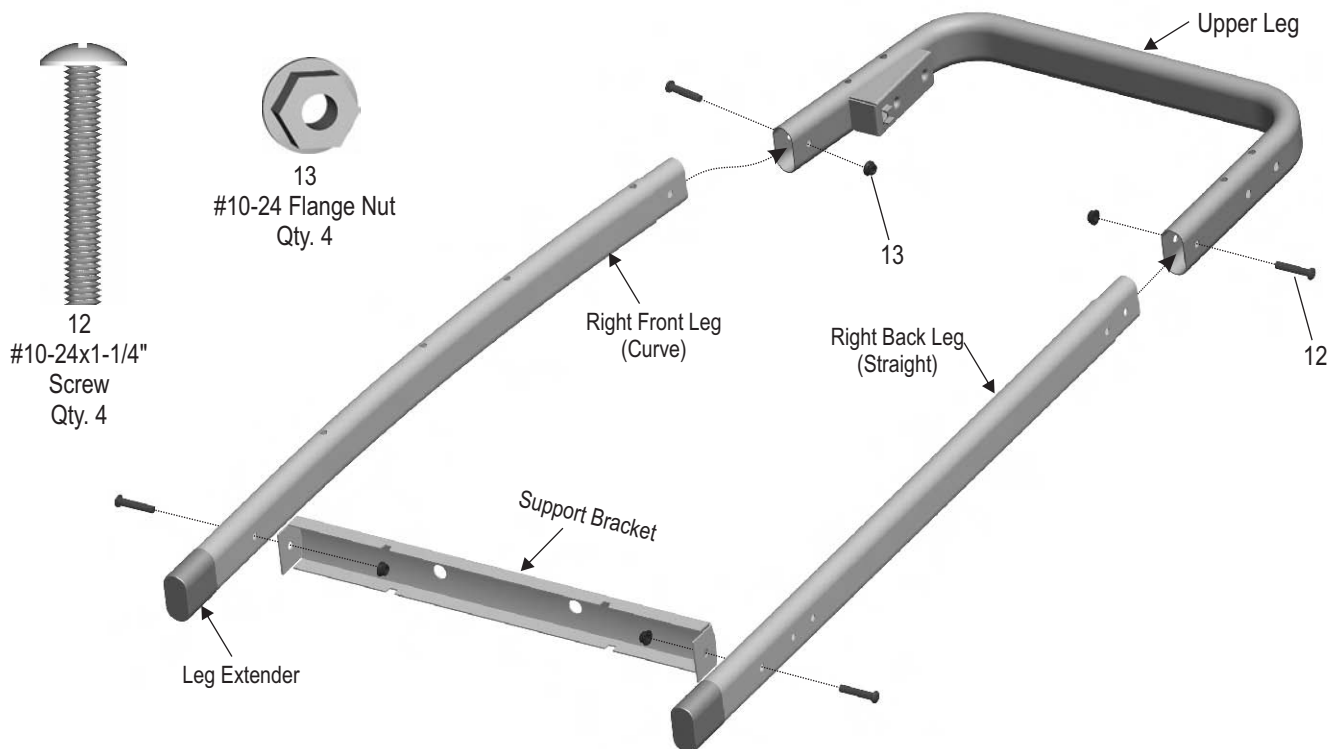



# 3

## Tank Exclusion Wire

- Hook tank exclusion wire into legs with opening for LP cylinder on side brace side.

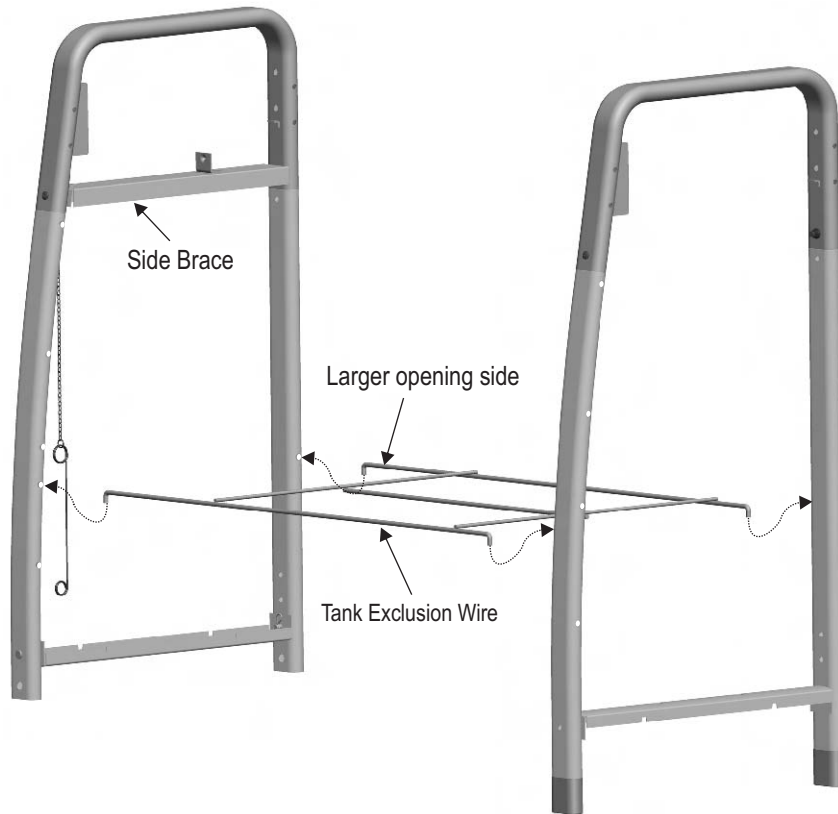

# 4

## Upper and Lower Panels

### Lay front legs down on the floor.

- Fit upper panel with two tabs between legs. Attach with **#10-24x2" screws** and **#10-24 flange nuts**.
- Fit lower panel around tank exclusion wire and attach with **#10-24x2" screws** and **#10-24 flange nuts**.

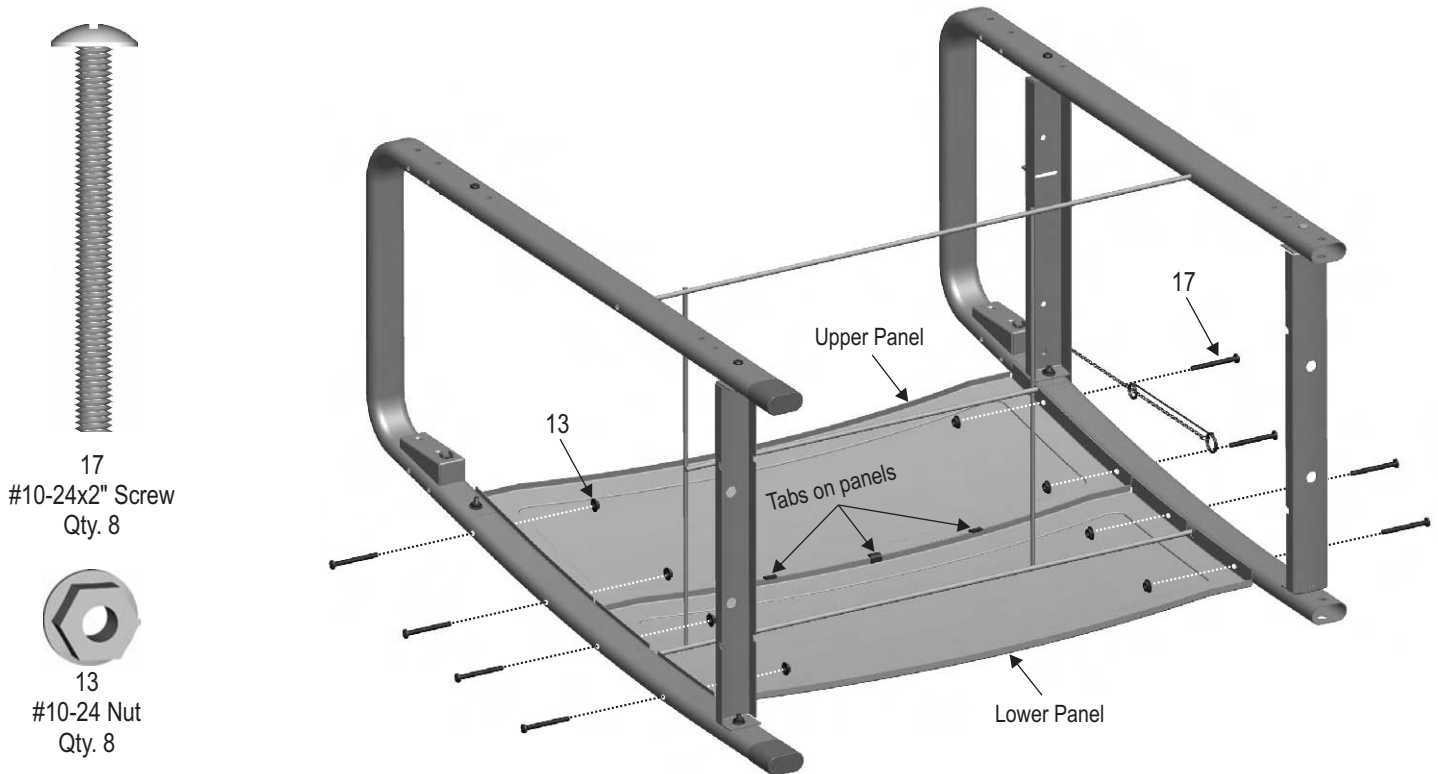

# 5

## Back Braces to Cart

- Remove previously attached screws and nuts from upper legs as shown. Attach back braces with **#10-24x1-1/4" screws** and **#10-24 flange nuts**.

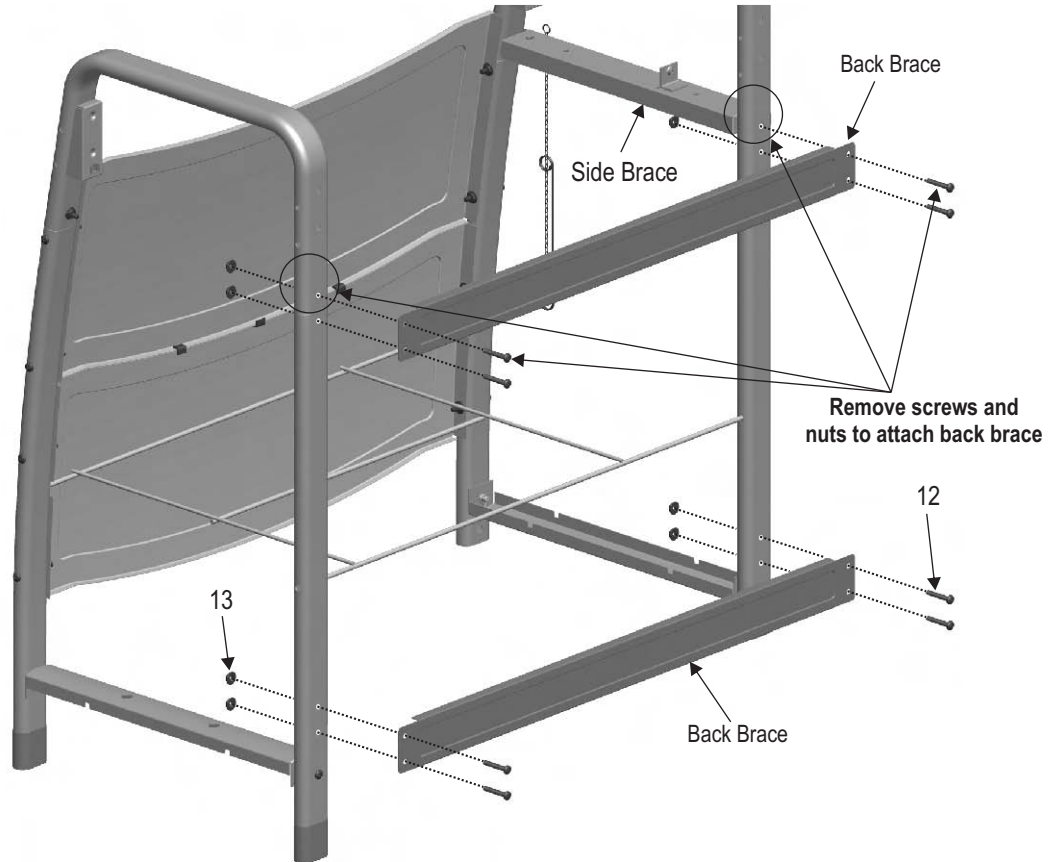

# 6

## Wheels

- Turn assembly upside down.
- Insert axle rod through wheel, legs and other wheel. Attach with a wheel bushing and hitch pin.

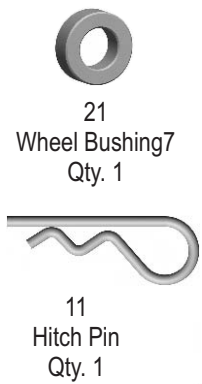

"Cone" side of wheel against leg

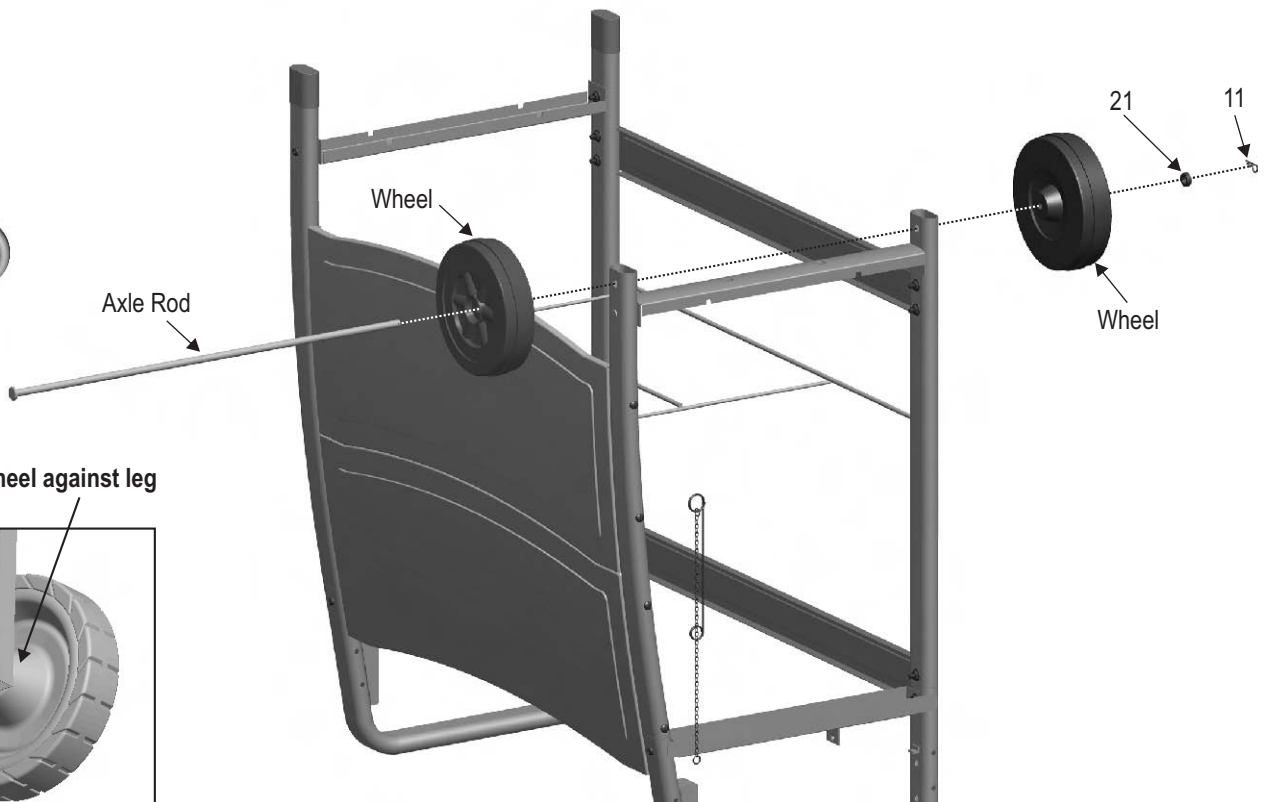
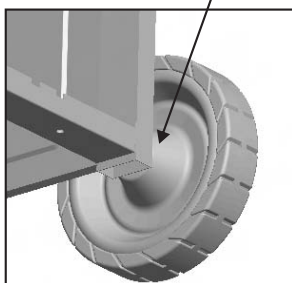

# 7

## Control Panel and Upper Firebox Supports

- Stand cart upright.
- In front, fit control panel between left and right legs. Insert **#10-24x2" screws** to hold panel in place. Place upper firebox supports onto screws making sure angle side is facing the front and attach with **#10-24 flange nuts**.
- In back, attach upper firebox support with **#10-24x2" screws** and **#10-24 flange nuts**.

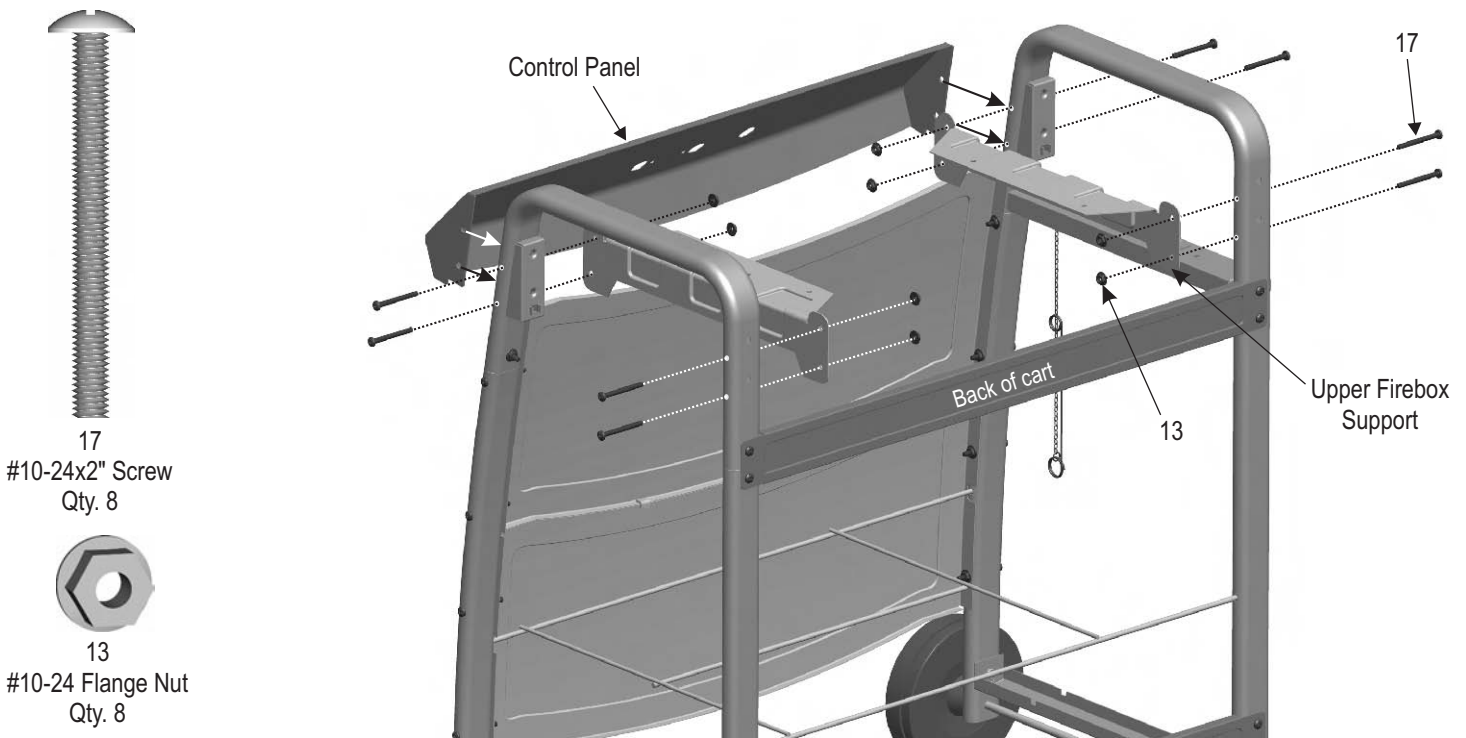

# 8

## Valve/Hose/Regulator and Electronic Ignition Module

- Attach valve/hose/regulator assembly to control panel with **#10-24x1/2" screws (A)**.
- Remove ignitor cap and plastic hex nut from Electronic Ignition module assembly. Insert module into the opening on control panel and attach with the removed hex nut. Place AA battery into module slot with positive end (+) facing outward. Screw ignitor cap onto module (**B**).

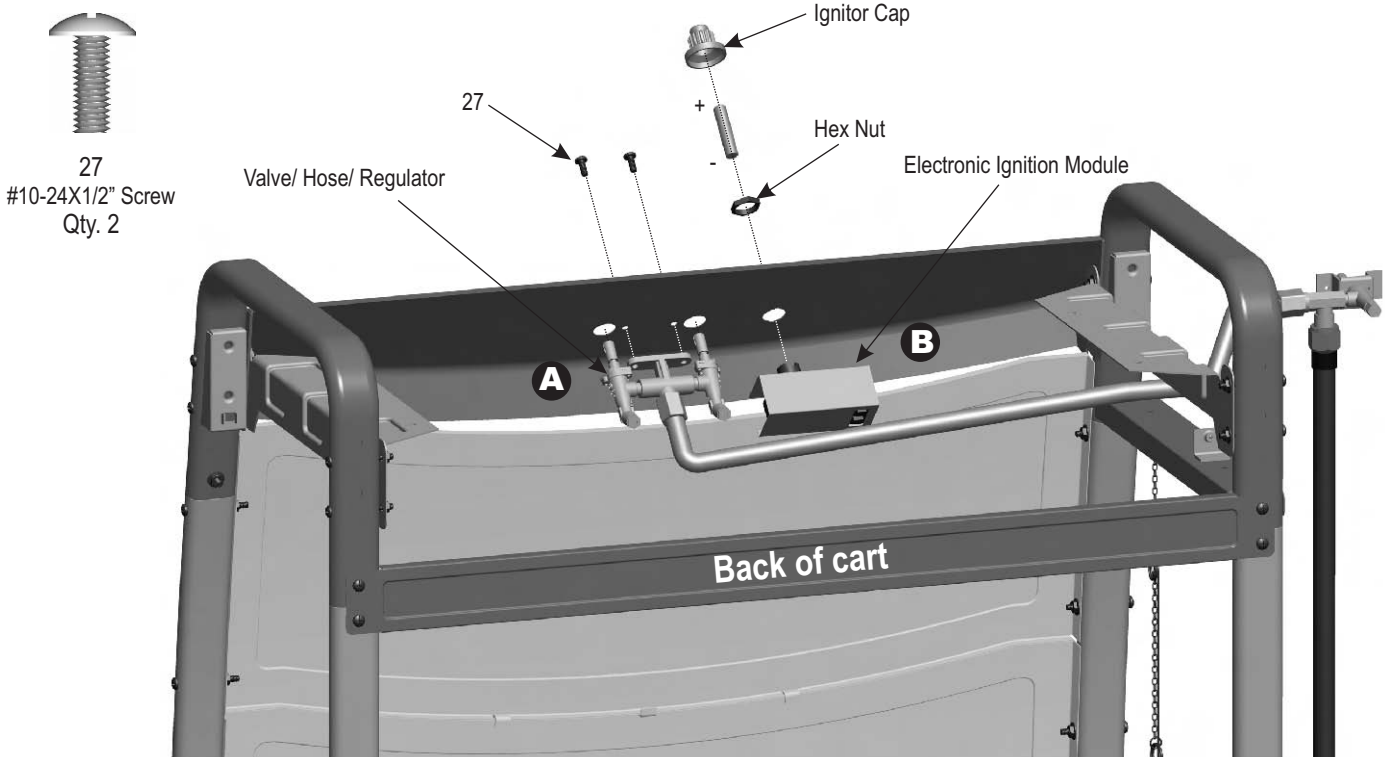

# 9

## Heat Shield

- Attach heat shield with #10-24x1/2" screws and #10-24 flange nuts.

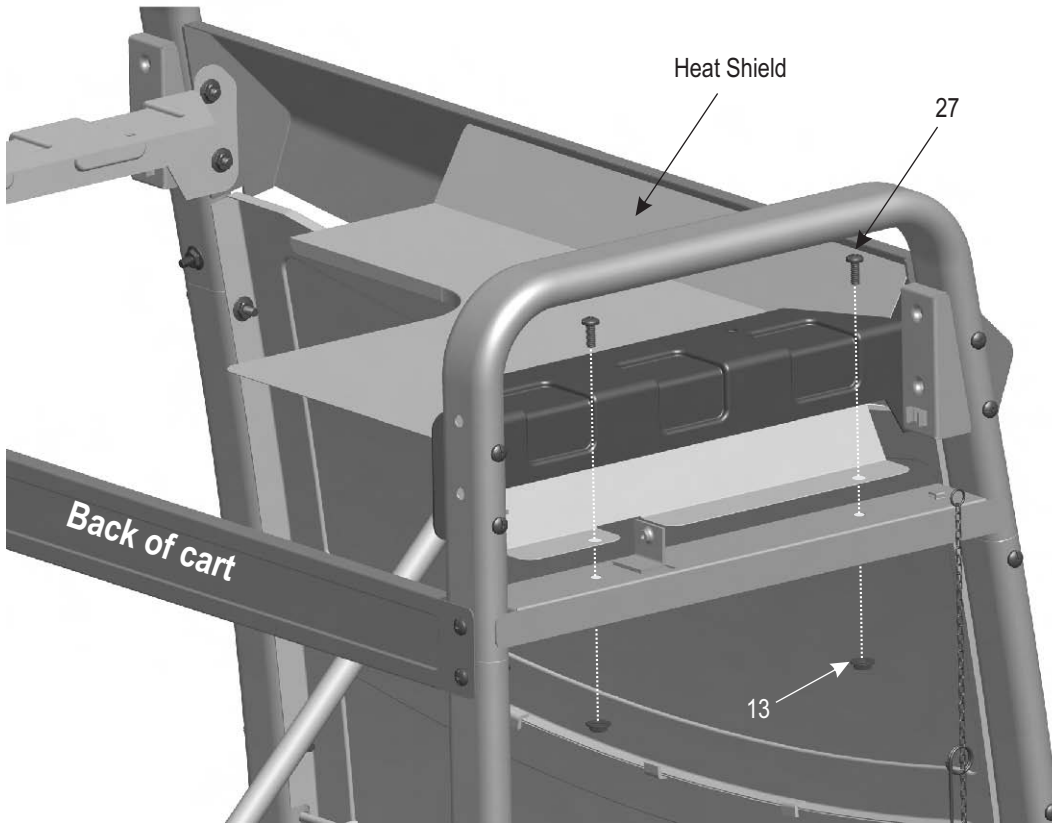

27  
#10-24X1/2" Screw  
Qty. 2



13  
#10-24 Flange Nut  
Qty. 2

# 10

## Tank Retainer

- Insert tank retainer into side brace and secure with wing screw.



30  
Wing Screw  
Qty. 1

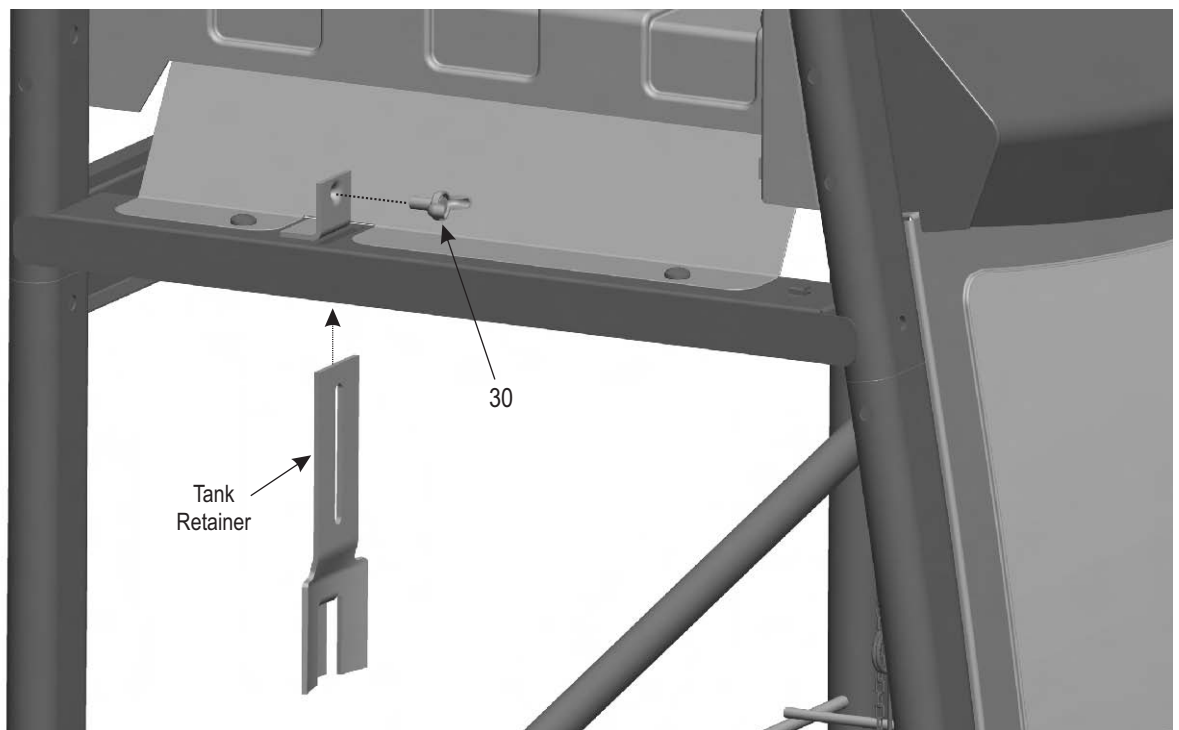

# 11

## Burner, Firebox and Control Knobs

- Place burner assembly into firebox (A). Fasten the burner assembly to the firebox using **5mm fiber washers** and **#10-24 x 1/2" machine screws**.
- Place firebox onto upper firebox supports with burner tubes below heat shield. **Make sure burner tubes are correctly engaged**. If burner is not leveled from left to right, adjust the two screws attaching valve stems to control panel. Attach ignitor wire to ignitor (B).
- Attach firebox with **#10-24x1/2" screws**, **5mm fiber washers** and **#10-24 flange nuts** (C).
- Push control knobs onto valve stems (C).

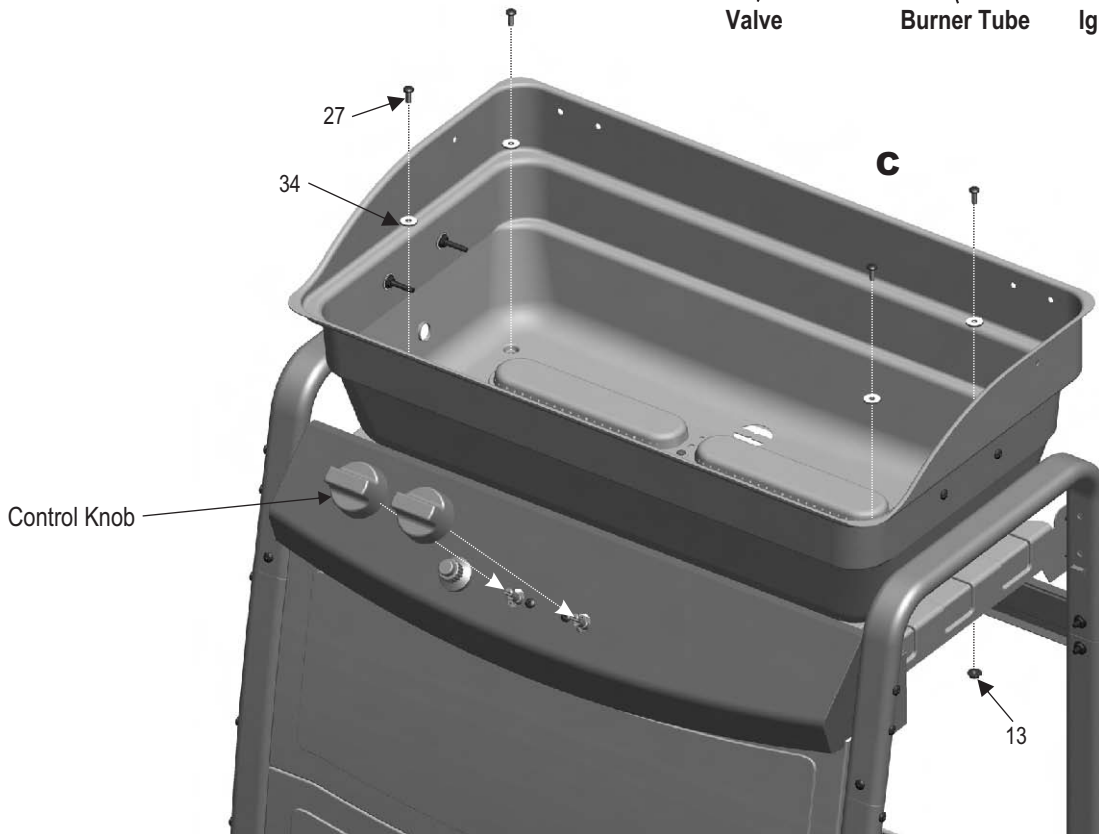
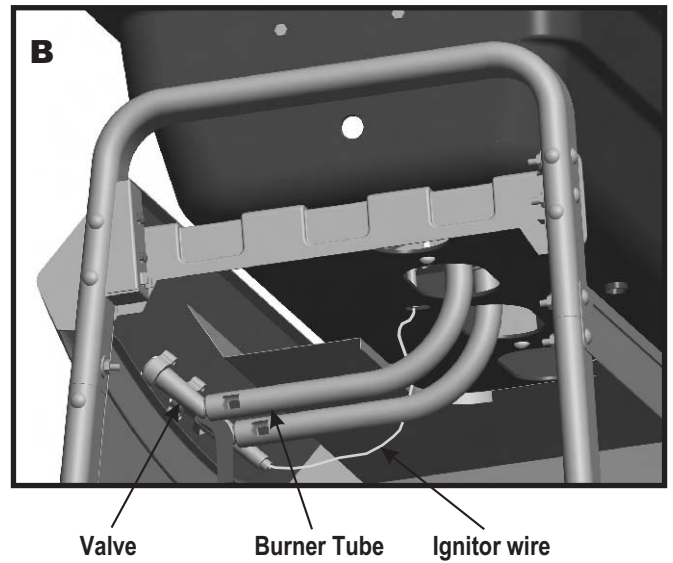
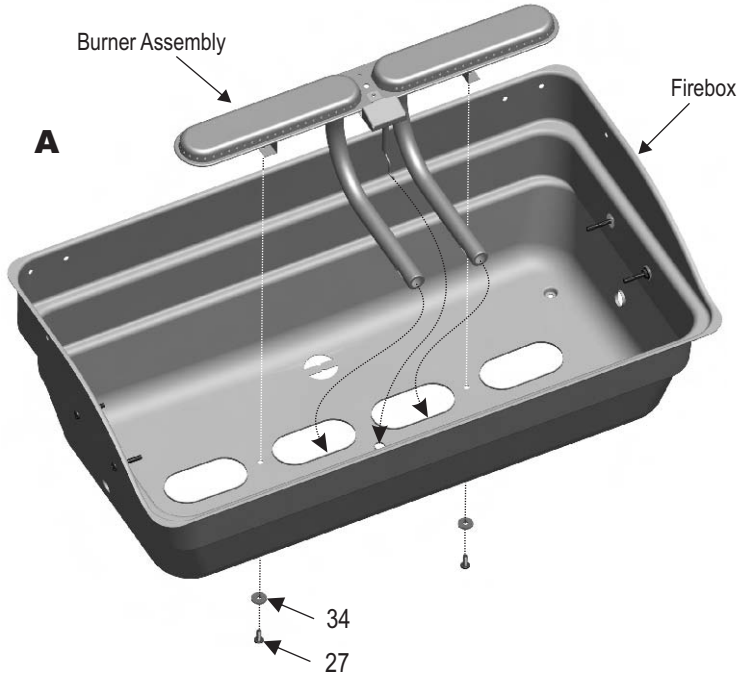



# 12

## Shelves

- Insert mounting brackets into side shelf supports with **#10-24x1/2" screws (A)**.
- Attach back of leg with **1/4"-20x1-1/4" screws** and **1/4"-20 flange nuts**. Do not fully tighten. Attach mounting brackets to front of leg with **1/4"-20x1/2" screws (B)**. Fully tighten all screws.
- Repeat above steps to attach side burner shelf to cart.

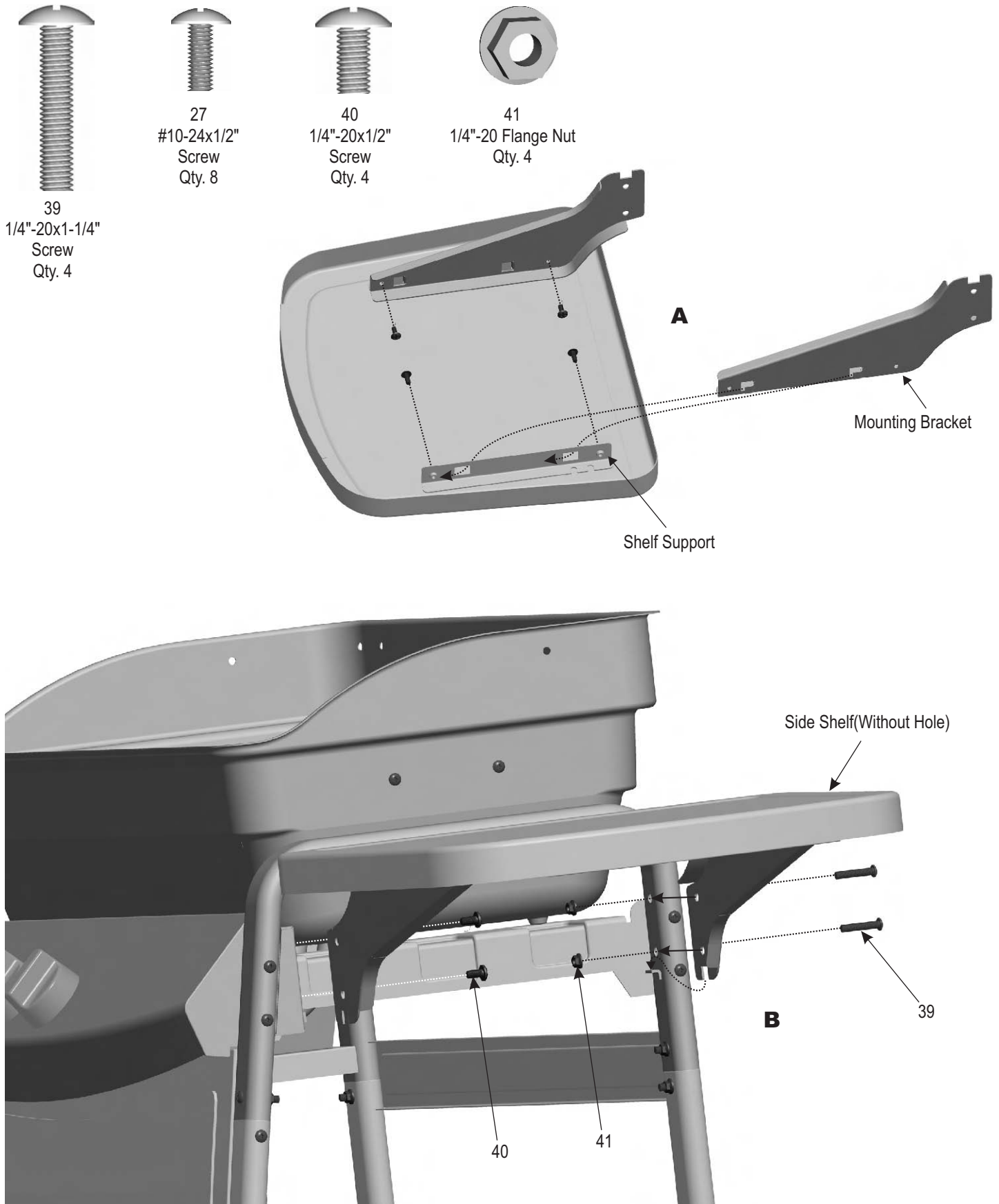

# 13

## Sideburner

- Attach sideburner valve with **#8-32x3/8" machine screws (A)**.
- Attach sideburner pan with **#8x3/8" self-tap screws** and **5mm ID 9mm OD fiber washers**. Place sideburner into shelf (**B**).
- Make sure valve is inside sideburner tube. Attach sideburner with **wing nut** and **5mm ID 9mm OD fiber washer**. Insert one end of burner clip into hole in sideburner tube and hook other end around valve manifold. Attach sideburner ignitor wire (**C**).
- Press sideburner control knob onto valve stem and sideburner grate onto shelf (**D**).
- Attach hinges to back of shelf with **#10-24x1/2" screws** and **#10-24 nuts** (**E**).

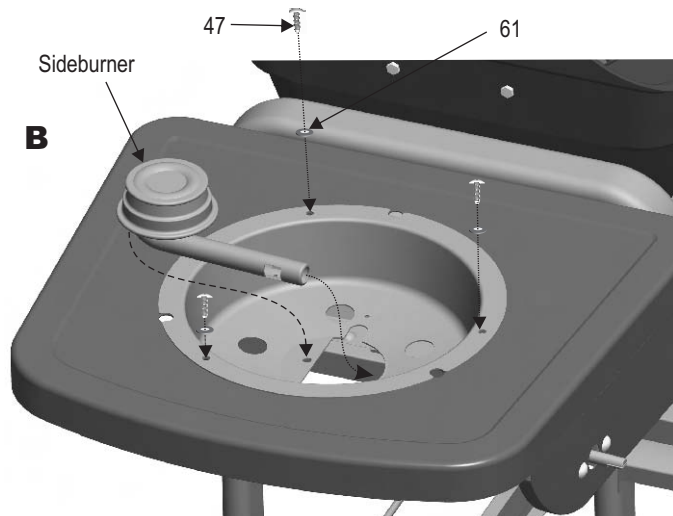
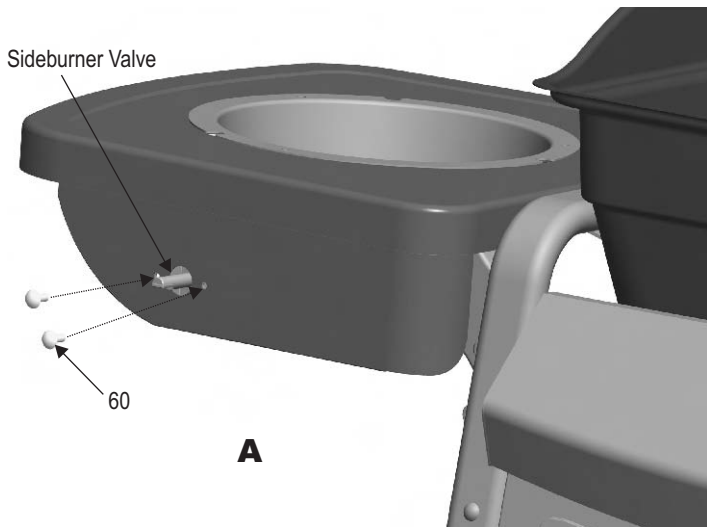

### Correctly assembled burner-to-valve engagement

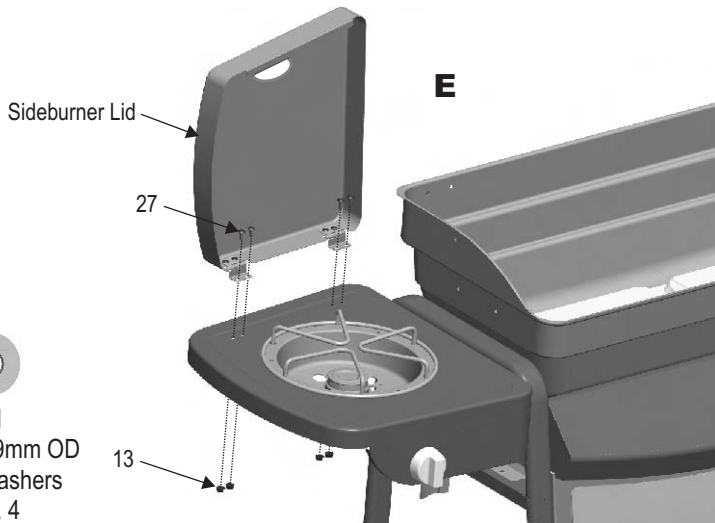
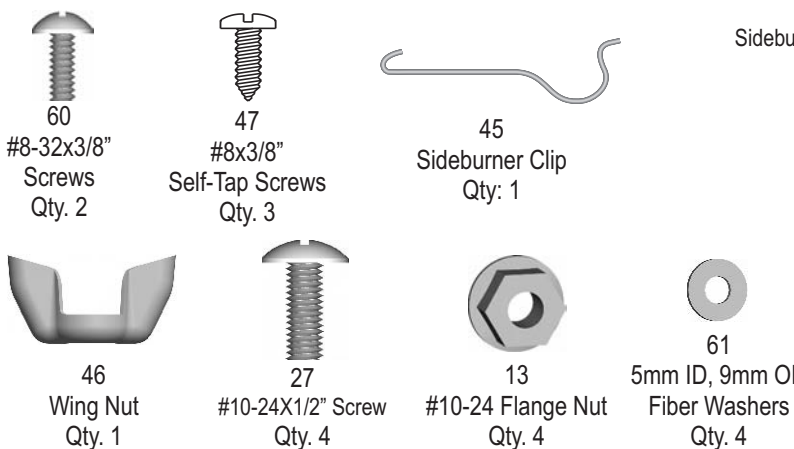
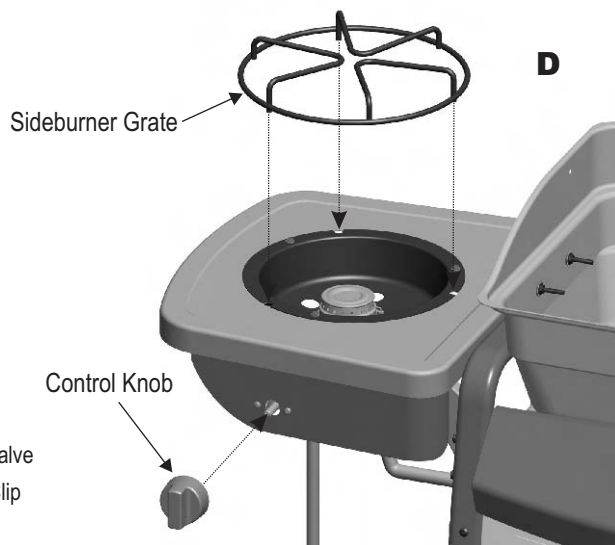
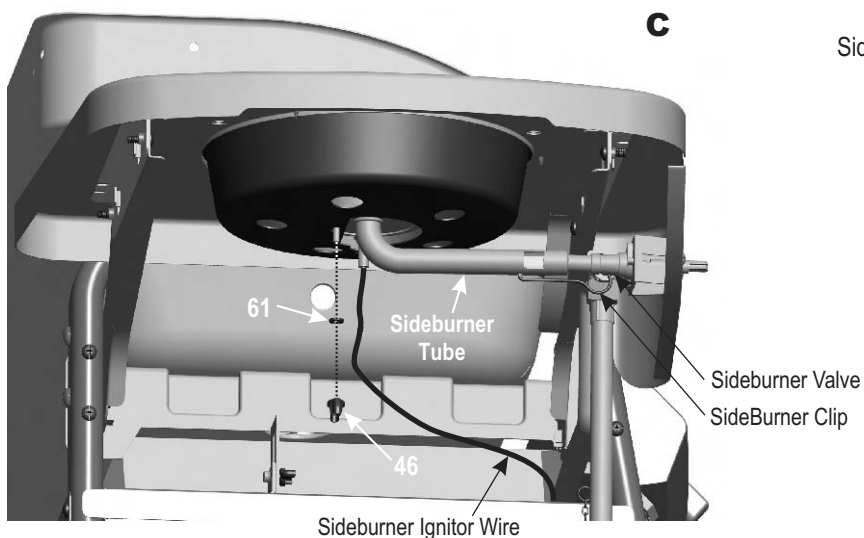

# 14

## Lower Firebox Hinges

- Attach lower hinges to back of firebox using **#10-24x1/2" screws, 5mm fiber washers and #10-24 flange nuts**. The center flat portion of the hinge should be at the bottom (see inset).

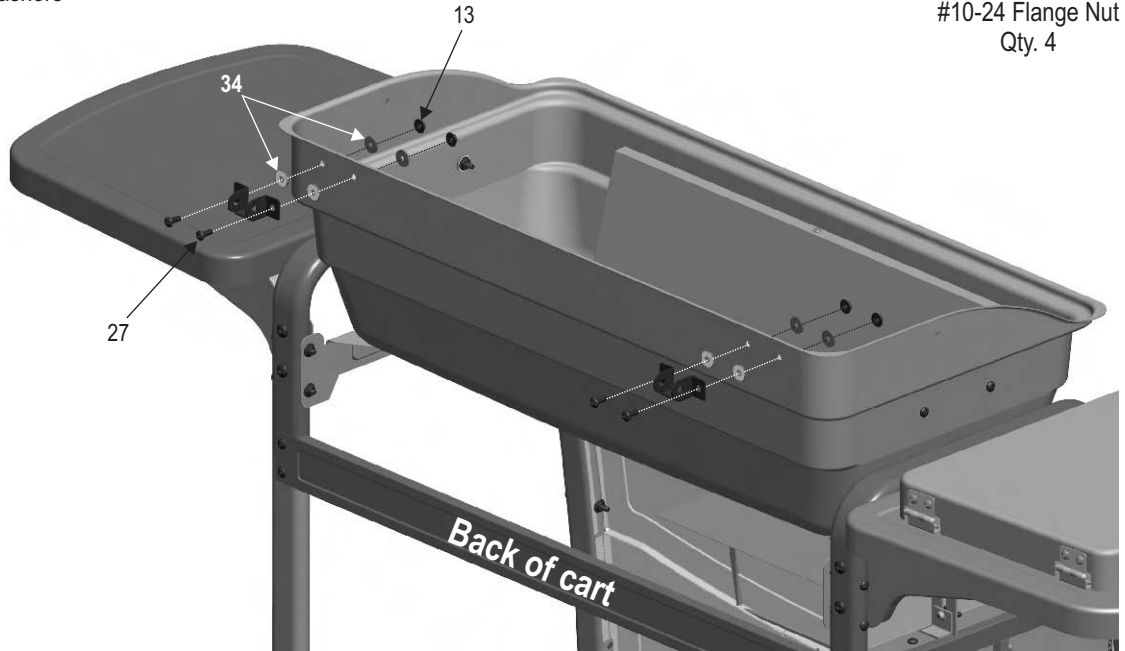
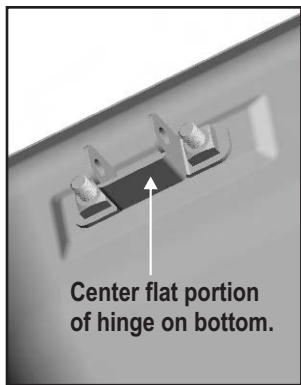

# 15

## Lid Handle and Upper Hinges

- Attach handle to lid with **5.5mm ID, 19mm OD fiber washers, 5.5mm ID, 19mm OD flat washers and #10-24x3/4" screws**.
- Attach upper hinges to back of lid with **#10-24x1/2" screws, 5mm fiber washers and #10-24 flange nuts**. Hinges should curve downward when properly installed.

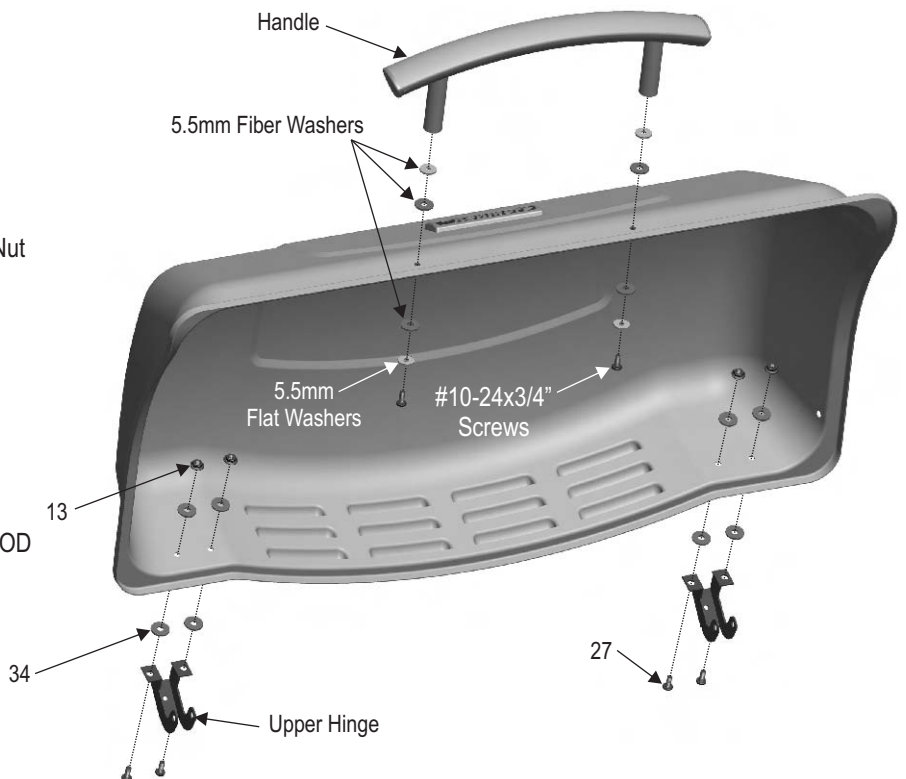

# 16

## Lid

- Place lid assembly onto firebox, aligning hinges. Hinges on lid fit inside hinges on firebox. Secure using two hinge pins and hitch pins (See inset ).



10  
Hinge Pins  
Qty. 2



11  
Hitch Pins  
Qty. 2

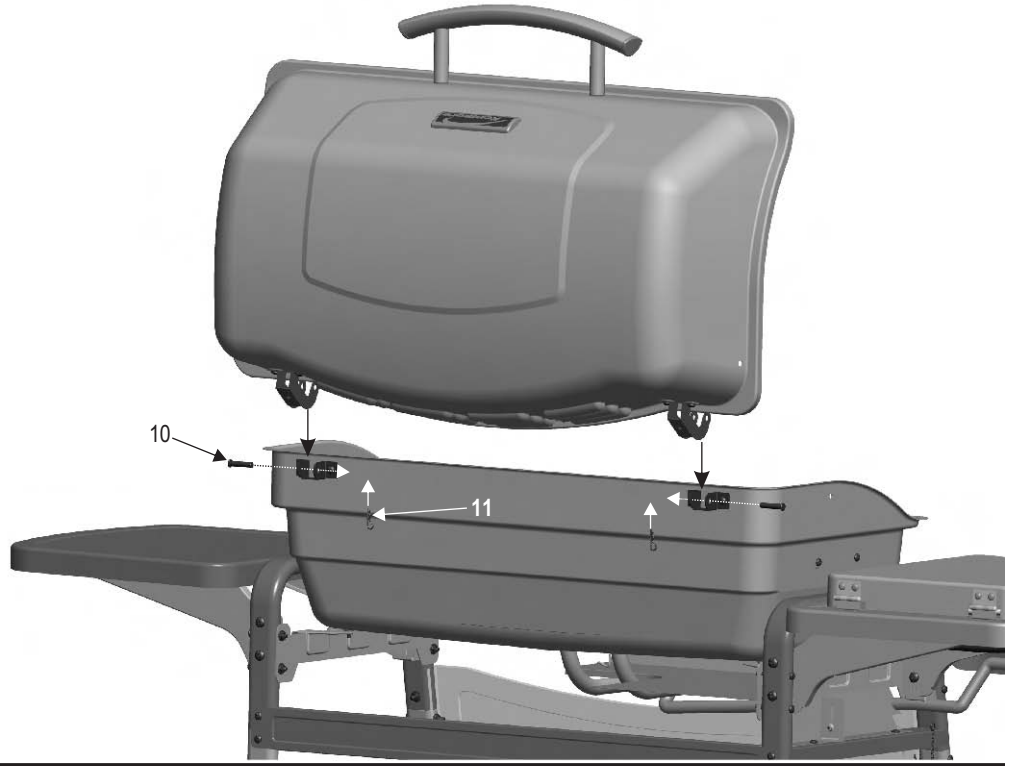
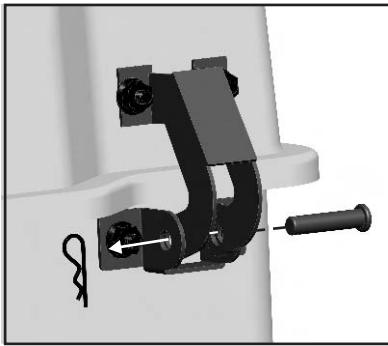

# 17

## Heat Diffuser

- Place heat diffuser over screws in firebox.

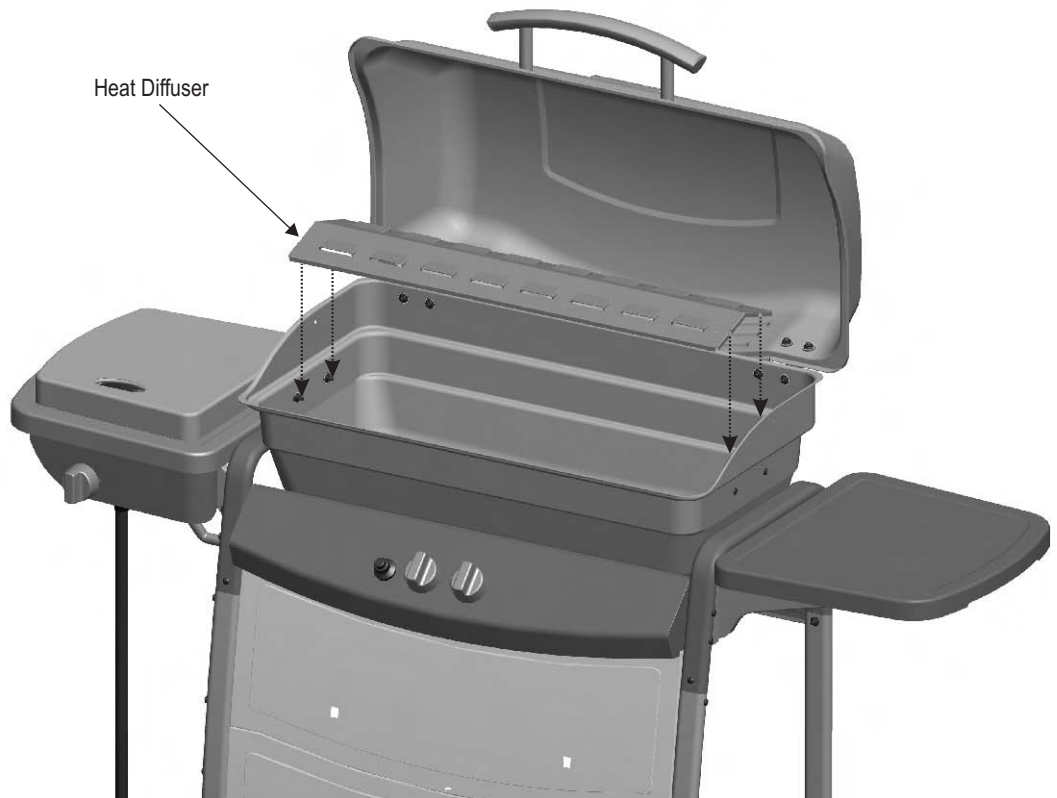

# 18

## Cooking Grate

- Place grate into firebox.



# 19

## Swing Away

- Insert ends of Swing Away pivot wire into holes in sides of grill lid. Insert ends of Swing Away leg wire into holes in sides of firebox.  
NOTE: Pivot and leg wires, running side-to-side, should be under wires running front-to-back. If pivot and leg wires are on top, Swing Away is installed upside-down.
- Attach condiment basket to upper front panel as shown.

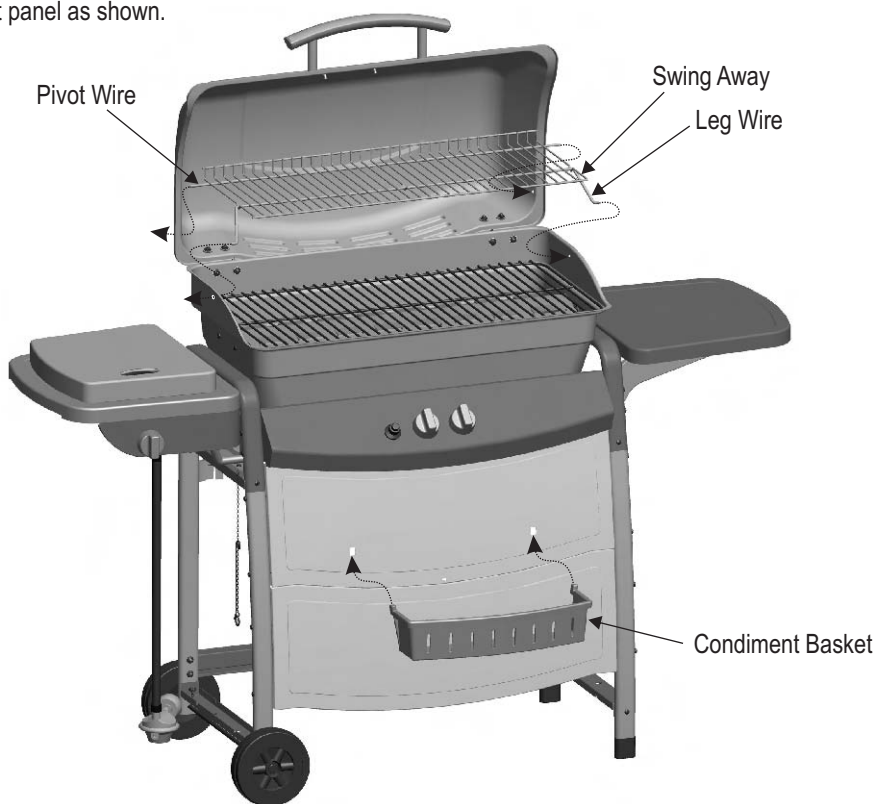



# 20

## Grease Cup Clip and Grease Cup

- Hang grease cup clip from bottom of firebox and place grease cup into grease cup clip.



### CAUTION

Failure to install grease cup clip and cup will cause hot grease to drip from bottom of grill with risk of fire or property damage.

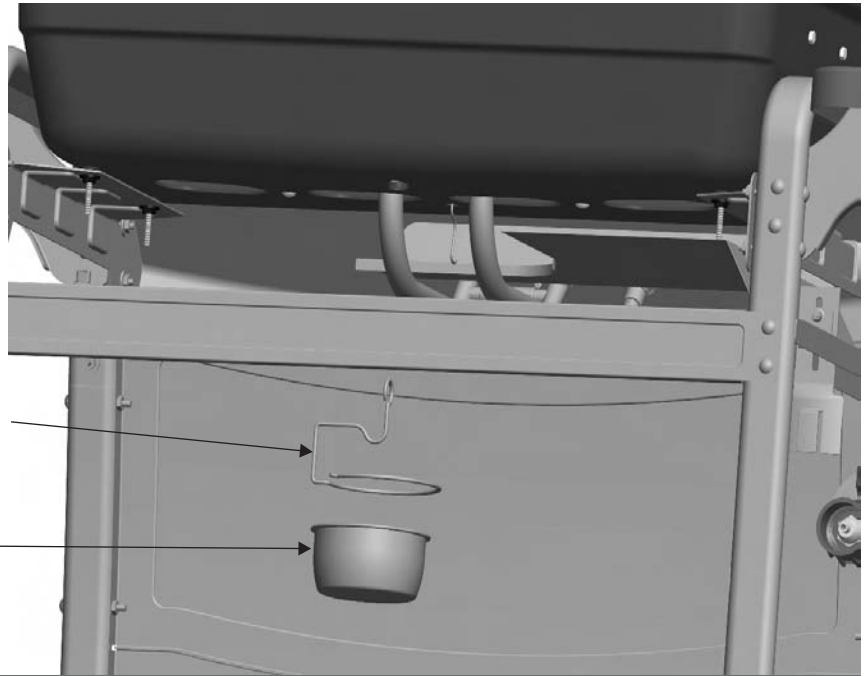

# 21

## LP Tank

- LP tank is sold separately. Use only with an OPD (over-fill protection device) equipped LP tank. Fill and leak check before attaching to grill and regulator. **See Use and Care section to correctly Leak Test and perform the Burner Flame Check.**
- Tank collar opening must face to front of grill. Loosen wing nut from tank retainer bracket. Set bottom of tank into notches in the tank bracket. Fit tank retainer bracket onto tank collar and tighten the wing nut.



### CAUTION

Cylinder valve must face to front of cart once tank is attached. Failure to install cylinder correctly may allow gas hose to be damaged in operation, resulting in the risk of fire.

**Always keep LP cylinders in upright position during use, transport, and storage.**



**Correctly Installed LP cylinder.**

## Troubleshooting

**EMERGENCIES: If a gas leak cannot be stopped, or a fire occurs due to gas leakage, call the fire department.**

Emergencies	Possible Cause	Prevention/Solution
Gas leaking from cracked/cut/burned hose.	<ul style="list-style-type: none"> <li>Damaged hose.</li> </ul>	<ul style="list-style-type: none"> <li>Turn off gas at LP tank. If hose is cut or cracked, replace valve/hose/regulator. See LP Tank Leak Test and Connecting Regulator To The LP Tank.</li> </ul>
Gas leaking from LP tank.	<ul style="list-style-type: none"> <li>Mechanical failure due to rusting or mishandling.</li> </ul>	<ul style="list-style-type: none"> <li>Turn off LP tank valve.</li> </ul>
Gas leaking from LP tank valve.	<ul style="list-style-type: none"> <li>Failure of tank valve from mishandling or mechanical failure.</li> </ul>	<ul style="list-style-type: none"> <li>Turn off LP tank valve. Return LP tank to gas supplier.</li> </ul>
Gas leaking between LP tank and regulator connection.	<ul style="list-style-type: none"> <li>Improper installation, connection not tight, failure of rubber seal.</li> </ul>	<ul style="list-style-type: none"> <li>Turn off LP tank valve. Remove regulator from cylinder and visually inspect rubber seal for damage. See LP Tank Leak Test and Connecting Regulator To The LP Tank.</li> </ul>
Fire coming through control panel.	<ul style="list-style-type: none"> <li>Fire in burner tube section of burner due to partial blockage.</li> </ul>	<ul style="list-style-type: none"> <li>Turn off control knobs and LP tank valve. Leave lid open to allow flames to die down. After fire is out and grill is cold, remove burner and inspect for spider nests or rust. See Natural Hazard and Cleaning The Burner Assembly pages.</li> </ul>
Troubleshooting: Problem	Possible Cause	Prevention/Solution
Grease fire or continuous excessive flames above cooking surface.	<ul style="list-style-type: none"> <li>Too much grease buildup in burner area.</li> </ul>	<ul style="list-style-type: none"> <li>Turn off LP tank valve. Leave lid open to allow flames to die down. After cooling, clean food particles and excess grease from inside firebox area, grease cup/pan/tray, and other surfaces.</li> </ul>
Burner(s) will not light using ignitor.	<p><b>GAS ISSUES:</b></p> <ul style="list-style-type: none"> <li>Trying to light wrong burner.</li> <li>Burner not engaged with control valve.</li> <li>Obstruction in burner.</li> <li>No gas flow.</li> <li>Vapor lock at coupling nut to LP tank.</li> <li>Coupling nut and LP tank valve not fully connected.</li> </ul>	<ul style="list-style-type: none"> <li>See instructions on control panel and section in the Use and Care.</li> <li>Make sure valves are positioned inside of burner tubes.</li> <li>Ensure burner tubes are not obstructed with spider webs or other matter. See cleaning section of Use and Care.</li> <li>Make sure LP tank is not empty. If LP tank is not empty, refer to "Sudden drop in gas flow."</li> <li>Turn off knobs and disconnect coupling nut from LP tank. Reconnect and retry.</li> <li>Turn the coupling nut approximately one-half to three-quarters additional turn until solid stop. Tighten by hand only - do not use tools.</li> </ul>
	<p><b>ELECTRICAL ISSUES:</b></p> <ul style="list-style-type: none"> <li>Electrode cracked or broken; "sparks at crack."</li> <li>Electrode tip not in proper position.</li> <li>Wire and/or electrode covered with cooking residue.</li> <li>Wires are loose or disconnected.</li> <li>Wires are shorting (sparking) between ignitor and electrode.</li> </ul>	<ul style="list-style-type: none"> <li>Replace electrode.</li> <li>Tip of electrode should be pointing toward port hole in burner. The distance should be 1/8" to 3/16". Adjust if necessary.</li> <li>Clean wire and/or electrode with rubbing alcohol and clean swab.</li> <li>Reconnect wires or replace electrode/wire assembly.</li> <li>Replace ignitor wire.</li> </ul>

*Continued on next page.*

## Troubleshooting (continued)

Problem	Possible Cause	Prevention/Solution
Burner(s) will not light using ignitor.	<ul style="list-style-type: none"> <li>• Push-button sticks at bottom..</li> <li>• Sparking between ignitor and electrode.</li> </ul>	<ul style="list-style-type: none"> <li>• Replace ignitor.</li> <li>• Inspect wire insulation and proper connection. Replace wires if insulation is broken.</li> </ul>
Burner(s) will not match light.	<ul style="list-style-type: none"> <li>• See “<b>GAS ISSUES:</b>” on previous page.</li> <li>• Improper method of match-lighting.</li> </ul>	<ul style="list-style-type: none"> <li>• See “Match-Lighting” section of Use and Care.</li> </ul>
Sudden drop in gas flow or low flame.	<ul style="list-style-type: none"> <li>• Out of gas.</li> <li>• Excess flow valve tripped.</li> <li>• Vapor lock at coupling nut/LP tank connection.</li> </ul>	<ul style="list-style-type: none"> <li>• Check for gas in LP tank.</li> <li>• Turn off knobs, wait 30 seconds and light grill. If flames are still low, turn off knobs and LP tank valve. Disconnect regulator. Reconnect regulator and leak-test. Turn on LP tank valve, wait 30 seconds and then light grill.</li> <li>• Turn off knobs and LP tank valve. Disconnect coupling nut from tank. Reconnect and retry.</li> </ul>
Flames blow out.	<ul style="list-style-type: none"> <li>• High or gusting winds.</li> <li>• Low on LP gas.</li> <li>• Excess flow valve tripped.</li> </ul>	<ul style="list-style-type: none"> <li>• Turn front of grill to face wind or increase flame height.</li> <li>• Refill LP tank.</li> <li>• Refer to “Sudden drop in gas flow” above.</li> </ul>
Flare-up.	<ul style="list-style-type: none"> <li>• Grease buildup.</li> <li>• Excessive fat in meat.</li> <li>• Excessive cooking temperature.</li> </ul>	<ul style="list-style-type: none"> <li>• Clean burners and inside of grill/firebox.</li> <li>• Trim fat from meat before grilling.</li> <li>• Adjust (lower) temperature accordingly.</li> </ul>
Persistent grease fire.	<ul style="list-style-type: none"> <li>• Grease trapped by food buildup around burner system.</li> </ul>	<ul style="list-style-type: none"> <li>• Turn knobs to OFF. Turn gas off at LP tank. Leave lid in position and let fire burn out. After grill cools, remove and clean all parts.</li> </ul>
Flashback... (fire in burner tube(s)).	<ul style="list-style-type: none"> <li>• Burner and/or burner tubes are blocked.</li> </ul>	<ul style="list-style-type: none"> <li>• Turn knobs to OFF. Clean burner and/or burner tubes. See burner cleaning section of Use and Care manual.</li> </ul>
Unable to fill LP tank.	<ul style="list-style-type: none"> <li>• Some dealers have older fill nozzles with worn threads.</li> </ul>	<ul style="list-style-type: none"> <li>• The worn nozzles don't have enough “bite” to engage the valve. Try a second LP dealer.</li> </ul>
One burner does not light from other burner(s).	<ul style="list-style-type: none"> <li>• Grease buildup or food particles in end(s) of carryover tube(s).</li> </ul>	<ul style="list-style-type: none"> <li>• Clean carry-over tube(s) with wire brush.</li> </ul>

## Troubleshooting - Electronic Ignition

Problem (Ignition)	Possible Cause	Check Procedure	Prevention/Solution
<p><b>SECTION I</b> No sparks appear at any electrodes when ignition button is pushed; no noise can be heard from spark module.</p>	<ul style="list-style-type: none"> <li>• Battery not installed properly.</li> <li>• Dead battery.</li> <li>• Button assembly not installed properly.</li> <li>• Faulty spark module.</li> </ul>	<ul style="list-style-type: none"> <li>• Check battery orientation.</li> <li>• Has battery been used previously?</li> <li>• Check to insure threads are properly engaged. Button should travel up and down without binding.</li> <li>• If no sparks are generated with new battery and good wire connections, module is faulty.</li> </ul>	<ul style="list-style-type: none"> <li>• Install battery (make sure that “+” and “-” connectors are oriented correctly, with “+” end up and “-” end down.)</li> <li>• Replace battery with new AA-size alkaline battery.</li> <li>• Unscrew button cap assembly and reinstall, making sure threads are aligned and engaged fully.</li> <li>• Replace spark module assembly.</li> </ul>
<p><b>SECTION II</b> No sparks appear at any electrodes when ignition switch is pushed; noise can be heard from spark module.</p>	<ul style="list-style-type: none"> <li>• Output lead connections not connected.</li> </ul>	<ul style="list-style-type: none"> <li>• Are output connections on and tight?</li> </ul>	<ul style="list-style-type: none"> <li>• Remove and reconnect all output connections at module and electrodes.</li> </ul>
<p><b>SECTION III</b> Sparks are present but not at all electrodes and/or not at full strength</p>	<ul style="list-style-type: none"> <li>• Output lead connections not connected.</li> <li>• Arcing to grill away from burner(s).</li> <li>• Weak battery.</li> <li>• Electrodes are wet.</li> <li>• Electrodes cracked or broken “sparks at crack”.</li> </ul>	<ul style="list-style-type: none"> <li>• Are output connections on and tight?</li> <li>• If possible, observe grill in dark location. Operate ignition system and look for arcing between output wires and grill frame.</li> <li>• All sparks present but weak or at slow rate.</li> <li>• Has moisture accumulated on electrode and/or in burner ports?</li> <li>• Inspect electrodes for cracks.</li> </ul>	<ul style="list-style-type: none"> <li>• Remove and reconnect all output connections at module and electrodes.</li> <li>• If sparks are observed other than from burner(s), wire insulation may be damaged. Replace wires.</li> <li>• Replace battery with a new AA-size alkaline battery.</li> <li>• Use paper towel to remove moisture.</li> <li>• Replace cracked or broken electrodes.</li> </ul>

# Get it fixed, at your home or ours!

## Your Home

For repair—in **your home**—of **all** major brand appliances, lawn and garden equipment, or heating and cooling systems, **no matter who made it, no matter who sold it!**

For the replacement parts, accessories and owner's manuals that you need to do-it-yourself.

For Sears professional installation of home appliances and items like garage door openers and water heaters.

**1-800-4-MY-HOME® (1-800-469-4663)**

Call anytime, day or night (U.S.A. and Canada)

[www.sears.com](http://www.sears.com)      [www.sears.ca](http://www.sears.ca)

For expert home solutions advice: [www.managemyhome.com](http://www.managemyhome.com)

---

## Our Home

For repair of carry-in items like vacuums, lawn equipment, and electronics, call or go on-line for the location of your nearest **Sears Parts & Repair Service Center**

**1-800-488-1222 (U.S.A) 1-800-469-4663 (Canada)**

Call anytime, day or night

[www.sears.com](http://www.sears.com)      [www.sears.ca](http://www.sears.ca)

---

To purchase a protection agreement on a product serviced by Sears:

**1-800-827-6655 (U.S.A.)**

**1-800-361-6665 (Canada)**

---

Para pedir servicio de reparación a domicilio, y para ordenar piezas:

**1-888-SU-HOGAR®**

(1-888-784-6427)

Au Canada pour service en français:

**1-800-LE-FOYER<sup>MC</sup>**

(1-800-533-6937)

[www.sears.ca](http://www.sears.ca)

