

Panasonic

ROOM AIR CONDITIONER

OPERATING INSTRUCTIONS

ENGLISH

MODEL: CW-XC122VU



Please read these operating instructions thoroughly before using your air conditioner and keep them for future reference.

For assistance, please call: 1-800-211-PANA (7262) or send e-mail to consumerproducts@panasonic.com or refer to www.panasonic.com

F563447

Please observe these following safety precautions when using your air conditioner.

- Failure or negligence in observing these safety precautions could cause fire, electrical shock or personal injury.



This symbol (with a white background) denotes an action that is **PROHIBITED**.



These symbols (with a blue background) denote actions that are **COMPULSORY**.

INSTALLATION PRECAUTIONS



- Due to the weight of this product, we recommend that you have a helper to assist in the installation. To avoid injury, use the proper method of lifting. Avoid any sharp edges.

- Make sure the window frame to be used can properly support this product.
- This product must be installed in accordance with all local codes and ordinances.



- Do not install the unit in places where inflammable gas, fumes or soot may be generated.

OPERATION PRECAUTIONS



- Operate your air conditioner from a stable 115 volt AC supply.
- Plug into a separate 15 amp grounded outlet only.
- Use of extension cords

Avoid using extension cords. If there are no alternatives, ensure that the cord is a UL listed 3-wire grounding type, rated 125 volts with a minimum current-carrying rating of 15 amps, number 14 or heavier wire.



- Use a 15 amp time delay fuse or a circuit breaker.
- Do not switch off by unplugging the power plug while it is operating. Press the OFF/ON pad to "OFF" before unplugging.

OPERATION PRECAUTIONS



WARNING This sign warns of risk of death or serious injury.



- Do not modify the length of the power cord or use an extension cord.
- Do not touch or operate with wet hands. Do not modify or damage the cord.
- Do not turn on the unit by inserting the power plug. Do not switch off the unit by pulling out the power plug.
- Avoid an extended period of direct airflow.
- Do not insert sticks, fingers or other objects into the unit.
- Do not try to repair the unit yourself.



- Plug in properly before operating and use a specified power cord.
- If abnormal conditions (burnt smell, etc) occur, switch off and remove the power plug.



CAUTION This sign warns of injury or damage to property.



- Do not use the unit for other purposes, than its intended use.
- Do not remove the power plug by pulling the cord.
- Do not block the air intake and outlet vanes.
- Do not splash or direct water at the unit
- Do not expose the unit to direct sunlight during operation.
- Do not operate the unit without the air filter installed or when the front intake grille has been removed.
- Do not place any objects on the unit.
- Do not operate any combustion equipment near the unit's airflow area.



- Switch off the breaker and remove the power plug from the socket if the unit will not be operated for a long period.
- Pay attention to any damages on the unit caused by extensive usage.
- Ventilate the room occasionally where the unit is installed.
- Remove the power plug when cleaning the unit.

POWER SUPPLY

Time Delay Fuse : 15 Amps
Rated Voltage : 115V



• Socket Type



• Line Cord Plug

INSTALLATION BOX CONTENTS

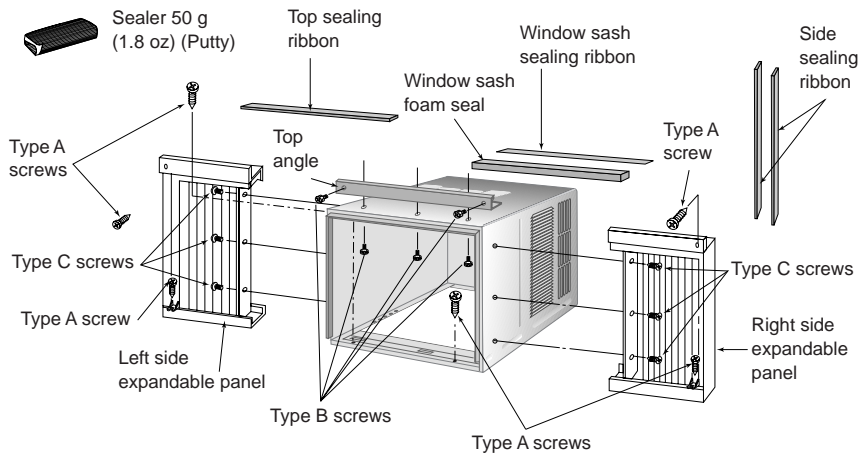

SCREW FURNISHED

| Type A (Qty 6) | Type B (Qty 5) | Type C (Qty 6) |
|-------------------|-------------------|-------------------|
| | | |
| Wood Screw | Machine Screw | Tapping Screw |

SUGGESTED TOOL LIST

- Medium sized screwdriver (#2 Phillips)
- Tape Measure
- Pencil
- Level
- Knife or Scissor

ACCESSORIES

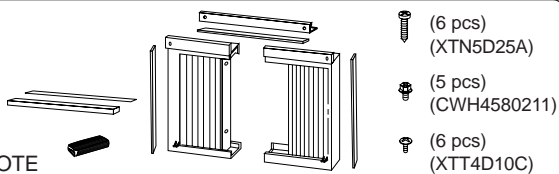

NOTE

Check that none of the accessories are missing.

SELECT THE BEST LOCATION

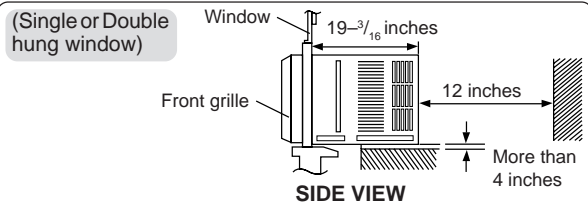

WINDOW REQUIREMENTS

- Hot sun rays hitting the outside surface of the cabinet will create considerable heat load. If the outside of the cabinet is exposed to direct sunlight, consider building an awning to shade the cabinet while providing ample area for the heated air to be exhausted from the condenser (both sides) and the top.

This unit is designed for installation in standard double hung windows.

NOTE

The unit may also be installed "through the wall". You should, however, observe standard carpentry practices and frame the opening without violating local ordinances.

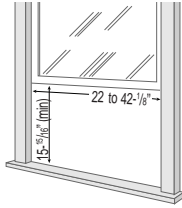

INSTALLATION PROCEDURES

- Remove the rear cabinet screws and save for later use.
- Slide the chassis out from the cabinet.

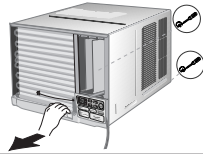

HOW TO ASSEMBLE THE EXPANDABLE PANELS

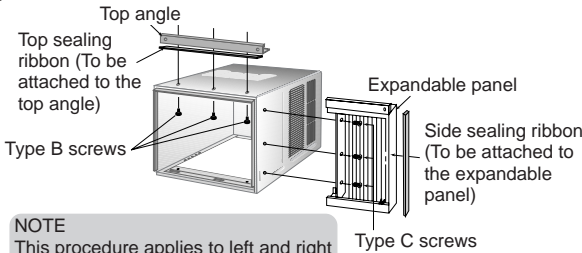

NOTE

This procedure applies to left and right of assembling expandable panel.

- Attach the top angle to the cabinet using screw type B (3 pcs).
- Insert expandable panels to cabinet sides as shown.
- Secure the first fold of expansion panel to cabinet using screw type C (3 each).

CABINET INSTALLATION

- Cut the "Sealing Ribbon" to the proper length, and attach it along the bottom edge of the bottom window sash.
- To prevent condensation water from dripping inside, the cabinet should be installed level or very slightly tilted to the outside.
- Secure the cabinet using screws.

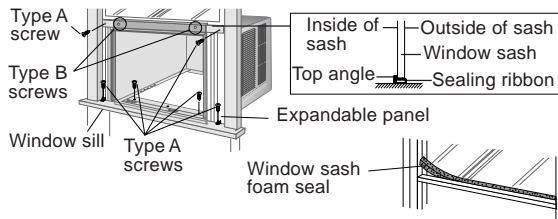
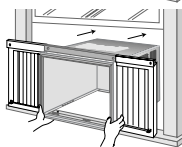

- Expand the expandable panel fully into the grooves of the window frame, secure the expandable panel, left, right and top mounting frames to the bottom of the window sash using 4 screws type A and 2 screws type B.
- Secure the cabinet using wood screws type A.
- Cut the window sash foam seal to the proper size and seal the opening between the top of the inside window sash and the outside window sash.

Note: If a gap exists between the unit and window sash, you may use "Sealer" supplied with the installation kit for a better seal.

CHASSIS INSTALLATION INTO THE CABINET

- Slide the chassis into the cabinet.
- Reinstall the cabinet screws. Secure the cabinet to chassis by using screws (from rear cabinet).

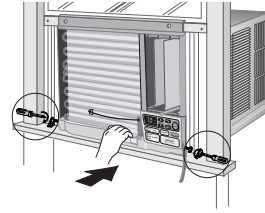

INSTALLATION OF THE FRONT GRILLE

Depending upon the location of the AC outlet, route the AC cord to either the left or right side while installing the front grille.

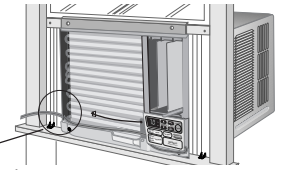

This figure shows the AC cord routed to the left side.

- Place the front grille on the cabinet first.
- Secure the front grille to the main chassis using screw provided.

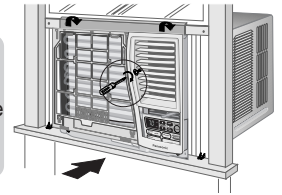

INSERT THE AIR FILTER

Attach the air filter to the intake grille

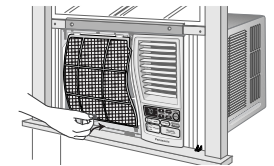

PLACE FRONT INTAKE GRILLE OVER THE FRONT GRILLE

Slide the front intake grille slightly to the right to reattach the tabs and then push it down to close tight.

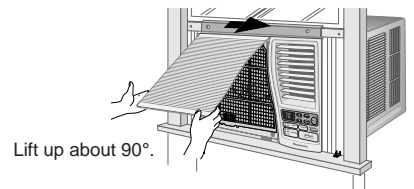

REMOVAL OF FRONT GRILLE

① Remove the front intake grille.

Pull up the front intake grille about 90° and slide it slightly to the left to unhook the tabs.

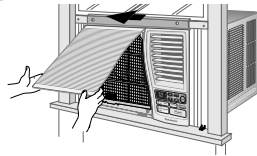

② Remove the air filter.

Tilt up and pull out the air filter by the holder.

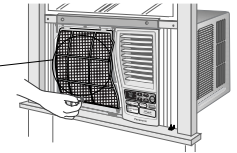
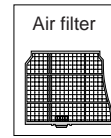

③ Remove the front grille.

- a Remove the adhesive tape from all sides of the front grille.
- b At bottom right side of the front grille, press inward on cabinet near the power cord, and pull the grille outward to the right until right tab releases.
- c At the bottom left side, push inward on cabinet and pull the grille outward to the left to release the left tab.
Do not pull the bottom edge toward you more than 3 inches to prevent the two top tabs from damage.
- d Slide the front grille upwards to free the two top tabs from slots at the top of the cabinet.

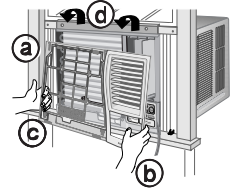

HOW TO ATTACH THE DRAIN PAN (OPTIONAL)

Condensed water drainage

This air conditioner employs a "Slinger-Up System" which is designed to splash the condensed water on the condenser coil for maximum cooling efficiency, thus producing a splashing sound. If the splashing sound annoys you, you can provide an outside drainage by using the following procedure which may, however, cause a small loss of performance.

Note: The cabinet should be installed tilted slightly lower to the rear for necessary condensate drainage. (Max. 13/32")

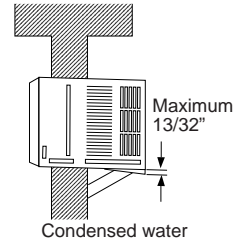

① Remove the rubber plug and slide the chassis out from the cabinet.

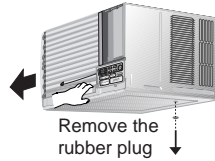

③ Connect a drain hose (optional).

Fit the drain hose to the drain pan.

Note
Drain hose or tubing can be purchased locally to satisfy your particular needs.

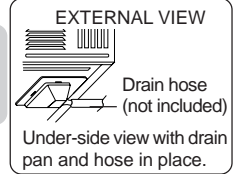

② Install the optional drain pan (part no. CWH40175).

Install the drain pan at the right corner of the cabinet using 2 screws (part no. CWG86C733).

Note
The drain pan (part no. CWH40175) can be obtained from nearest servicenter.

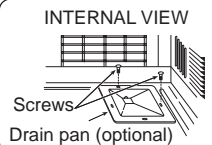

④ Slide the chassis back into the cabinet.

Reinstall the cabinet screws.
Secure the cabinet to chassis by using screws.



MAIN UNIT



⑧ Ventilation lever



CLOSE VENT OPEN

The ventilation lever must be in the CLOSE position in order to maintain the best cooling conditions. When fresh air is necessary in the room, set the ventilation lever to the OPEN position. The damper is opened and room air is drawn out.

- ① Air inlet louver
- ② Cabinet

- ③ Power cord

- ④ Air filter
- ⑤ Front intake grille
- ⑥ Front grille
- ⑦ Vertical airflow direction vane (Airflow direction adjustment up-down).
The vertical airflow direction vane is controlled by rotating the horizontal vane forward or backward.



⑨ Touch control panel

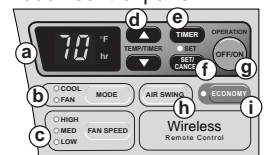

- a Display Panel
- b MODE selection pad
- c FAN SPEED selection pad
- d TEMPERATURE/TIMER setting pad
- e TIMER pad
- f Timer SET/CANCEL pad
- g OPERATION OFF/ON pad
- h AIR SWING pad
- i ECONOMY pad

TYPES OF SIGNAL SOUND

One long "Beep" and one short "Beep". (Sound from the main unit.)

ACCESSORIES

- Remote control
- Two R03 dry-cell batteries

REMOTE CONTROL

- ① Signal Transmitter
- ② OPERATION button
- ③ TEMPERATURE/TIMER setting button
- ④ TIMER button
- ⑤ TIMER SET/CANCEL button
- ⑥ MODE selection button
- ⑦ ECONOMY Button
- ⑧ AIR SWING button
- ⑨ Fan Speed Selection Button



Be sure to observe the following:

- Aim remote control at control panel on air conditioner when operating.
- Do not drop or throw the remote control.
- Do not place the remote control in a location that is exposed to direct sunlight or next to a heating unit or other heat sources.

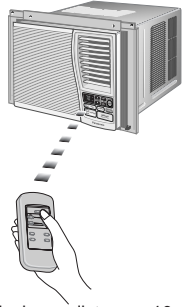

• Maximum distance : 10 m

WARNING

Ensure that the power plug is securely inserted. A loose plug may cause a fire or an electric shock.

NOTES

- If the unit is not going to be used for an extended period of time, remove the power plug. Otherwise, approximately 2.5W of electricity will be used even if the unit has been turned off using the remote control.
- If operation is stopped, and to be restarted immediately, the unit will resume operation only after 3 minutes.

HOW TO INSERT BATTERIES

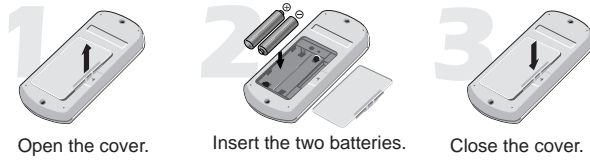

Open the cover. Insert the two batteries. Close the cover.

CAUTION

Do not use rechargeable (Ni-Cd) batteries because such batteries differ from the standard dry cell batteries in shape, dimension and performance.

ABOUT THE BATTERIES

- The batteries can be used for approximately one year.
- Be sure to replace the batteries with two new identical batteries.
- Remove the batteries if the air conditioner will not be used for an extended period of time.

OPERATING THE UNIT

Start operation by pressing OPERATION. The operation will turn on and the display panel will light up. To stop the operation, press the OPERATION again. The unit will stop operating and the display panel light will turn off.

SETTING DISPLAY TEMPERATURE

Press TEMP/TIMER ▲ or ▼ to set the display temperature. The temperature can be set between 60°F and 86°F. Recommended temperature: 75°F ~ 78°F.

NOTES

- The latest temperature setting will be memorized and will appear on the display the next time it's turned on.
- The display temperature selection is for display purpose only and does not indicate actual room setting temperatures. Your room temperature may not necessarily match the displayed temperature.

SELECTING FAN SPEED

Press FAN SPEED to choose the speed level of the fan. The indicator will light up and the "beep" sound will indicate changing setting.

NOTE

- The latest fan speed setting will be memorized and the indicator will light up the next time the unit is turned on.

SELECTING OPERATION MODE

Press MODE to select the desired operation. The indicator will light up and a "beep" sound will indicate changing setting.

COOL mode
To set room temperature to your preference of cooling comfort.

FAN mode
To provide air circulation without cooling the room. During Fan operation, temperature setting cannot be selected.

ADJUSTING HORIZONTAL AIR FLOW DIRECTION

Press to select AIR SWING. The air circulation will automatically move the horizontal louvers left and right for better air distribution around the room.

NOTE
Using your hands to adjust the direction may cause the louvers to malfunction. If this happens, stop operation immediately and restart.

Vertical adjustment of the airflow direction is done manually.

ECONOMY OPERATION

To reduce power consumption:

- Press ECONOMY.
- To cancel this operation, press once more.

ECONOMY

Recommended for electricity cost saving. When economy button is pressed, target temperature is shifted up 1°F, this will reduce operating time of the compressor and therefore reduce power consumption. It may, however, take a little longer for the compressor to cycle on and thereby increase the room temperature slightly. Economy mode will override your current set fan speed to "LOW". However, the display will still show the current set fan speed. Compressor stops when the room temperature reaches the target temperature. It turns on again when the room temperature rises. When power failure occurs, the economy setting is canceled. Once power is resumed, reset the economy setting.

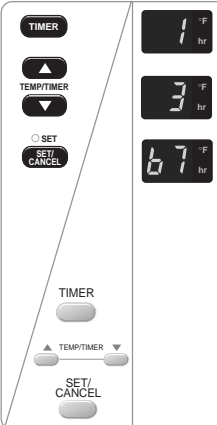
SETTING THE OFF TIMER

When the air conditioner is operation:
Press the TIMER button.
The SET/CANCEL indicator light will blink awaiting for setting.
Press the TEMP/TIMER ▲ or ▼ button until the preferred hour of operation is reached.
Press the SET/CANCEL button to complete the setting. At this time, the SET/CANCEL indicator light is steady instead of blinking.

NOTE
The hour reading will change back to the set temperature reading after 10 seconds. (You can also revert to temperature setting immediately by pressing the TEMP/TIMER ▲ or ▼ buttons again.)

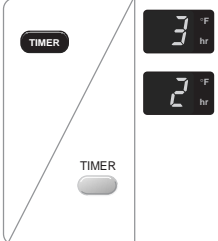
CHECK TIMER SETTING DURING OFF TIMER

Press the TIMER button to check the remaining programmed timer setting. The figure will be displayed for 10 seconds then will automatically switch back to temperature setting.

NOTE
The timer figure will change according to the time remaining (if you set it to turn off 3 hours from now, the timer will show "2" at an hour later).

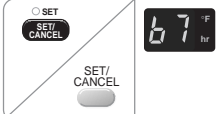
CANCEL TIMER SETTING DURING OFF TIMER

Press the SET/CANCEL button to cancel the timer setting. The SET/CANCEL indicator light will turn off. However the temperature remains displayed.

| | | | |
|----------------------|-----------------|-------------|---|
| Model | CW-XC122VU | | |
| COOLING CAPACITY | Btu/h | 11,500 | |
| ELECTRICAL RATING | Phase | Single | |
| | Frequency (Hz) | 60 | |
| | Voltage (V) | 115 | |
| | Current (Amps) | 10.1 | |
| | Input (W) | 1150 | |
| EER | (Btu/W.h) | 10.0 | |
| MOISTURE REMOVAL | (Pints/h) | 3.0 | |
| ROOM AIR CIRCULATION | (Cf/min) | 330 | |
| DIMENSIONS | Height | cm (inches) | 37.5 (14 ⁻²⁵ / ₃₂ " |
| | Width | cm (inches) | 56 (22 ⁻¹ / ₁₆ " |
| | Depth | cm (inches) | 60.6 (23 ⁻²⁷ / ₃₂ " |
| NET WEIGHT | kg (lb) | 35 (77) | |
| GROSS WEIGHT | kg (lb) | 39 (86) | |
| NOISE LEVEL | Indoor (Hi/Lo) | dB (A) | 51/47 |
| | Outdoor (Hi/Lo) | dB (A) | 58/55 |

* Specifications are subject to change without notice for further improvement.

RANDOM AUTO RESTART

Random Auto Restart

- Operation will automatically resume under the previous operation mode.
- If the unit was set to TIMER mode, operation will not resume automatically.
- When power failure occurs, the timer setting is canceled. Once power returns, reset the timer.

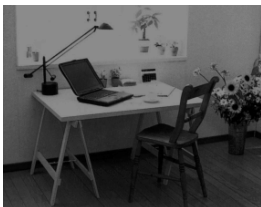

ENERGY SAVING HINTS

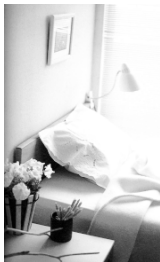

- Setting the temperature 1°F higher save 10% electricity costs.
- Regular cleaning of the air filter preserves efficiency.
- Keeping openings closed keeps cool air in and hot air out.
- Avoid direct sunlight and heat.
- For health reasons do not overcool your room.
- Your air conditioner's cooling capacity should match your room size.



CAUTION Always turn off the air conditioner and the main power supply before clean the unit. Switch off the power supply if the unit is not going to be used for a long period of time.



- Clean the cabinet, front grille with a mild soap or detergent and lukewarm water.
- The front intake grille can be easily removed for cleaning purposes. Gently wash it with water and a sponge.
- The filter can be easily cleaned using a vacuum cleaner. Vacuum the front of the filter and then wash the rear with water. If it is badly soiled, wash with a mild household detergent.
- Do not clean with benzene, thinner, scouring powder or cloth soaked in caustic chemicals.
- If the unit is extremely dirty, heat transfer is less efficient and the unit may not cool effectively. Contact your nearest servicenter for an annual check.
- If the air filter becomes clogged with dust, the cooling capacity will drop, and 6% of the electricity used to operate the air conditioner will be wasted.

NOTE

Do not dry the front panel or the air filter in direct sunlight. (Exposure to direct sunlight may discolor or deform the panel.)

PRE-SEASON INSPECTION

- *Is the discharged air cold?*
After 15 minutes of operation, it is normal for the temperature difference between intake and outlet air to be more than 14.4°F for cooling.
- *Are the air intake and outlet vanes of the indoor and outdoor side obstructed?*
- *Are the remote control batteries weak?*

RECOMMENDED INSPECTION

- Usage over several seasons will reduce performance as the unit becomes dirty.
A dirty unit may produce foul odors and dust may clog the dehumidifying drainage.
Seasonal inspection is recommended in addition to regular cleaning. Consult your nearest servicenter.

BEFORE



Check the following points before calling for repairs or service. If the malfunction persists, please contact your nearest servicenter. For assistance, please call: 1-800-211-PANA (7262) or send e-mail to: consumerproducts@panasonic.com

POSSIBLE CAUSES OF THE ABOVE PROBLEMS

Condition ① If the unit is too noisy during operation.

The following sounds are normal during operation:

- A low humming sound indicating that the unit is operating.
- A soft clicking sound when the compressor turns on and off.
- A flowing sound due to circulation of the refrigerant when the compressor is turned on.
- A splashing sound indicating condensation in the condenser coil.

If you hear other noises, please consult your nearest servicenter.

Condition ② If the unit does not operate.

- The main power cord is not plugged in.
- The internal fuse has blown.
- The main circuit breaker has tripped.
- Remote control batteries are weak.

Condition ③ If the unit does not cool properly.

- The room is too big for the unit's cooling capacity.
- The ventilation lever is set to OPEN.
- The air circulation is impeded by curtains or furniture.
- After 15 minutes of operation, it is normal for the temperature difference between intake and outlet air to be more than 14.4°F for cooling.

Condition ④ If water drips off the rear of the unit.

- Humidity is high.
- Condensed water is overflowing.
- To rectify the problem, mount a drain pan to the unit.

Condition ⑤ If water drips inside the room.

- The unit is tilted inward. To rectify this, tilt the unit slightly outward.
- Mount the optional drain pan if you prefer.

If the trouble persists after you have checked all of these, call your authorized Panasonic dealer or servicenter. Service information can be obtained 24 hours/day by calling: 1-800-211-PANA (7262)

- To expedite the repair of your air conditioner:
- Please have your proof of purchase.
 - List all symptoms the unit is exhibiting.

**Panasonic Consumer Electronics Company,
Division of Matsushita Electric Corporation
of America**

One Panasonic Way
Secaucus, New Jersey 07094

**Panasonic Sales Company,
Division of Matsushita Electric of Puerto Rico, Inc.,**

Ave. 65 de Infanteria, Km. 9.5
San Gabriel Industrial Park
Carolina, Puerto Rico 00985

Panasonic Room Air Conditioner Limited Warranty

Panasonic Consumer Electronics Company or Panasonic Sales Company (collectively referred to as "the Warrantor") will repair this product with new or refurbished parts in case of defects in material or workmanship, free of charge, in the USA or Puerto Rico in accordance to the following (All time periods start from the date of the original purchase).

SEALED REFRIGERATING SYSTEM (compressor and interconnecting tube): FIVE (5) YEARS - PARTS AND LABOR

ALL OTHER COMPONENTS: ONE (1) YEAR - PARTS AND LABOR

In-home service in the USA can be obtained during the warranty period by contacting a Panasonic Service Company (PASC) Factory Servicenter listed in the Servicenter Directory. Or call toll free, 1-800-211-PANA(7262), to locate a PASC authorized Servicenter. In-home service in Puerto Rico can be obtained during the warranty period by calling the Panasonic Sales Company telephone number listed in the Servicenter Directory.

Note: If the unit is installed at the other than normal window height and/or has been custom-installed (e.g., through the wall), the customer is responsible for removing the unit from its installation prior to the performance of in-home service.

This warranty is extended only to the original purchaser. A purchase receipt or other proof of date of the original purchase is required for service and parts replacement under this warranty.

This warranty only covers failures due to defects in materials and workmanship and does not cover normal wear or cosmetic damage. The warranty does not cover damages which occur in shipment, or failures which are caused by products not supplied by the warrantor, or failures which result from accident, misuse, abuse, neglect, mishandling, misapplication, faulty installation, maladjustment of customer controls, improper maintenance, alteration, modification, power line surge, lightning damage, improper voltage supply, commercial use such as hotel, office, restaurant, or other business or rental use of the product, or service by anyone other than a PASC Factory Servicenter or a PASC authorized Servicenter, or damage that is attributable to acts of God.

LIMITS AND EXCLUSIONS

There are no express warranties except as listed above.

THE WARRANTOR SHALL NOT BE LIABLE FOR INCIDENTAL OR CONSEQUENTIAL DAMAGES RESULTING FROM THE USE OF THIS PRODUCT, OR ARISING OUT OF ANY BREACH OF THIS WARRANTY. ALL EXPRESS AND IMPLIED WARRANTIES, INCLUDING THE WARRANTIES OF MERCHANTABILITY, ARE LIMITED TO THE APPLICABLE WARRANTY PERIOD SET FORTH ABOVE.

Some states do not allow the exclusion or limitation of incidental or consequential damages, or limitations on how long an implied warranty lasts, so the above exclusions or limitations may not apply to you.

This warranty gives you specific legal rights and you may also have other rights which vary from state to state. If a problem with this product develops during or after the warranty period, you may contact your dealer or Servicenter. If the problem is not handled to your satisfaction, then write to the Consumer Affairs Department at the company address indicated above.

SERVICE CALLS WHICH DO NOT INVOLVE DEFECTIVE MATERIALS OR WORKMANSHIP AS DETERMINED BY THE WARRANTOR, IN ITS SOLE DISCRETION, ARE NOT COVERED. COSTS OF SUCH SERVICE CALLS ARE THE RESPONSIBILITY OF THE PURCHASER.

[For assistance, please call: 1-800-211-PANA (7262) or send e-mail to consumerproducts@panasonic.com]