

CAPT'N COOK XG3CKWA Owner's Manual

[Shop genuine replacement parts for CAPT'N COOK
XG3CKWA](#)

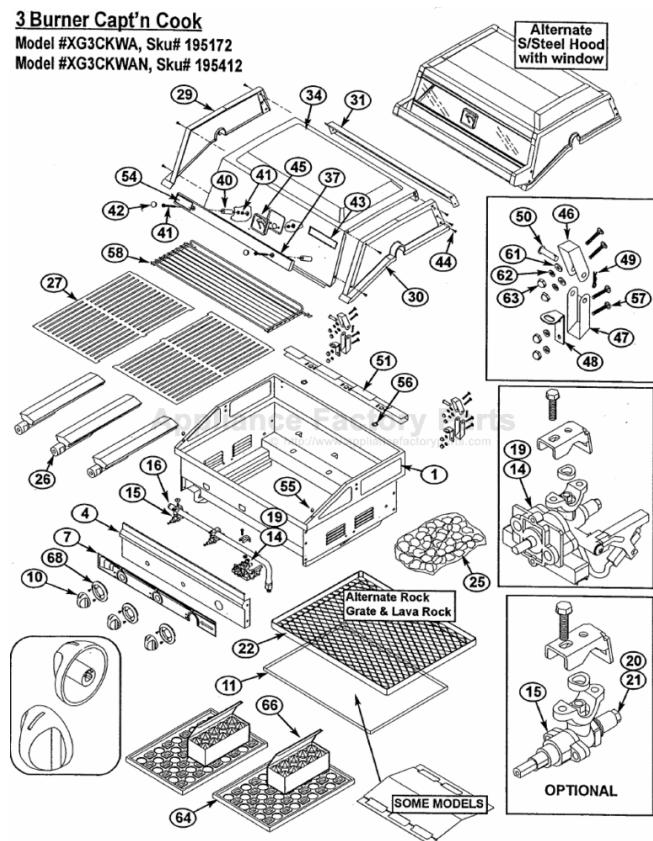

[Find Your CAPT'N COOK Grill Parts - Select From 19 Models](#)

----- Manual continues below -----

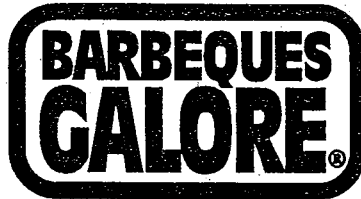

CAPTAIN COOK®

Instruction Manual For All 3, 4 and 5 Burner Models

XG3CKWA • XG4CKWA • XG5CKWA • XG3CKWNA • XG4CKWNA • XG5CKWNA

Note: We highly recommend you always cover this barbecue when it is not in use which will prolong the life of the barbecue and protect it from the elements.

FOR YOUR SAFETY: IF YOU SMELL GAS

1. Shut off gas to the appliance.
2. Extinguish any open flame.
3. Open lid.
4. If odor continues, call your gas supplier immediately or your fire department.
5. Do not store or use gasoline or other flammable vapors and liquids in the vicinity of this or any other appliance.
6. An LP cylinder not connected for use should not be stored in the vicinity of this or any other appliance.

WARNING:

All barbecues and carts are designed for outdoor use only!

All barbecues are not intended for commercial use.



Safety Information

WARNING: Fuels used in gas or oil-fired appliances and the products of combustion of such fuels, contain chemicals known to the State of California to cause cancer, birth defects and/ or other reproductive harm.

This warning is issued pursuant to California Health & Safety Code Sec. 25249.6.

You have bought a quality gas product from Barbeques Galore. All gas products require careful installation and or assembly and pre-operational testing. We recommend that our trained staff assemble, test and if necessary install your new purchase for you.

Barbeques Galore cannot be held responsible for any damages to persons or property resulting from improper assembly or installation.

If you chose to assemble, test and install your own unit, please follow the manufacturer's instructions explicitly.

NOTE TO INSTALLER:

Leave these instructions with the consumer for future reference.

THIS OUTDOOR COOKING GAS APPLIANCE IS NOT INTENDED TO BE INSTALLED IN OR ON RECREATIONAL VEHICLES AND/OR BOATS

GAS PRESSURE

The **Propane grill** is designed to operate on propane at a gas pressure regulated at 11" water column (W.C.) when equipped with the correct Propane Orifices on the valves and a **Propane Regulator** on the supply line.

The **Natural Gas Grill** is designed to operate on Natural Gas at a gas pressure regulated at 4" water column (W.C.) when equipped with the correct Natural Gas Orifice on the valves and a **Natural Gas Regulator** on the supply line.

GENERAL INFORMATION

The installation of your Gas grill must meet all local codes and/or gas utility requirements or, in the absence of local codes, with the National Fuel Gas Code, ANSI Z223.1.

CAUTION: LEAK CHECKING

Check all gas connections with a soap solution to be sure they are tight and leakproof. To make soap solution, mix one part water with one part liquid detergent. With heat control knobs at "OFF" position, turn gas supply on. Apply the mixture to all gas pipe connections. Soap bubbles will appear if connections are not properly sealed; repair as necessary. Never test for gas leaks with a lighted match or open flame.

This barbecue is supplied from the factory equipped for use with **Propane or Natural Gas** depending on unit purchased and includes appropriate regulator.

Propane Units:

Self contained Propane gas system Mobile Cart

The Self-Contained Gas System Gas grill is designed to be used with a standard 20 lbs. gas cylinder. Do not connect to a Propane gas cylinder exceeding this capacity. The cylinder should not exceed 18 inches in height and 12 inches in diameter, and must be constructed and marked in accordance with specifications of the U.S. Department of Transportation for Propane gas cylinders.

The cylinder must also be equipped with:

- A) A collar to protect the Propane gas valve.
- B) A shutoff valve terminating a Propane gas cylinder valve outlet **QCC-1** (Quick Connect Coupling Type 1) as specified in the American National Standard for Compressed Gas Cylinder Valve Outlets and Inlet Connections, ANSI Z.21-58.
- C) A safety relief valve having direct communications with the vapor space of the cylinder;
- D) An arrangement for vapor withdrawal; and
- E) A bottom rim with holes for securing tank support assembly.

Propane is safe to use when properly handled, careless handling of the Propane gas cylinder could result in a fire and/or an explosion. Therefore:

- A) Always keep cylinder securely fastened in an upright position.
- B) Avoid tipping cylinder on its side when connected to a regulator since this may cause damage to diaphragm in regulator.
- C) Handle tank valves with care.
- D) Never connect an unregulated Propane gas cylinder to the grill.
- E) Do not subject Propane cylinders to excessive heat.
- F) Tightly close the gas shut-off valve on the Propane gas cylinder after each use.
- G) The QCC-1 Fitting must be protected when disconnected from the Propane tank. If fitting is allowed to drag on the ground, nicks and scratches could occur resulting in a leak when connected to the tank. Retain and use the plastic protector cap provided.

H) CAUTION:

Never store a Propane gas cylinder inside a building or in the vicinity of any gas burning apparatus. Between cook-outs, when the Propane gas supply cylinder is not disconnected from the Gas grill, the cylinder and grill must be stored outdoors in a well ventilated area, out of the reach of children. If for any reason the Gas grill is to be stored indoors, the cylinder must be disconnected and removed from the grill cart and stored outdoors in a well ventilated area out of the reach of children. The plastic cylinder valve plug supplied with your Barbecue must be tightly installed when the cylinder is disconnected from the unit. **THE DISCONNECTED CYLINDER MUST NEVER BE STORED IN A BUILDING, GARAGE OR ANY OTHER ENCLOSED AREA.**

The LP gas pressure regulator and hose assembly supplied with this unit must be used without alteration. If this assembly needs to be replaced, use only the type specified by Barbeques Galore for this appliance.

When connecting the LP gas regulator to the supply cylinder, please remember that the threaded fittings on the QCC-1 valve tightens clockwise (Figure 1). This connection must be tightened fully to prevent leakage.

- 1) If your Propane tank should ever require repainting use a light colored paint to allow heat reflection. Never use a dark color to repaint the Propane tank.

This appliance is for outdoor use in a well-ventilated area only. This unit must not be used in a building, garage or any other enclosed area.

Natural Gas Units:

When connecting a unit to the natural gas supply in your home, please ensure the pipe joint compound is resistant to the action of natural gas. In addition, please observe the following:

The barbecue and its individual shut-off valve must be disconnected from the gas supply piping system during any pressure testing of that system at test pressures in excess of 1/2 psi (3.5 kPa).

The barbecue must be isolated from the gas supply piping system by closing its individual manual shut-off valve during any pressure testing of the gas supply piping system at test pressures equal to or less than 1/2 psi (3.5 kPa)

A natural gas regulator **MUST** be installed in the gas supply line from the house.

Please remember to check all gas connections for leaks after the piping is completed. Follow the procedure found on page 2, under the heading "CAUTION: LEAK CHECKING."

CAUTION: ELECTRICAL WARNING

If your grill incorporates electrical components they must be installed in accordance with local codes or in the absence of local codes, with the National Electrical Code, ANSI/NFPA No.70-1987.

The electric cord for the optional rotisserie motor is equipped with a three-prong 115v plug, and must be used with a grounded outlet. If it is not designed for a three wire plug, you must obtain an adapter and properly ground it before using the rotisserie. Do not cut or remove the grounding prong from the plug.

KEEP ANY ELECTRICAL SUPPLY CORD AND THE FUEL SUPPLY HOSE AWAY FROM ANY HEATED SURFACE.

Barbeques Galore Limited Warranty

Barbeques Galore hereby warrants to the ORIGINAL PURCHASER of this Barbeques Galore Gas Barbecue that it will be free of defects in material and workmanship from the date of purchase as follows:

Porcelainized Cast Iron Grills, Steel and Wood Carts.....	2 years
Porcelainized Steel Frame, Housing, Solid & Porcelain Coated Cast Iron Burners.....	5 years
Solid Brass Burners.....	10 years
Solid Cast Stainless Steel Burners.....	15 years
Painted BBQ Frames, Igniter Assemblies and All Remaining Parts.....	1 year

when assembled and operated in accordance with the printed instructions that accompany it.

Barbeques Galore shall not be liable under this or any implied warranty for incidental or consequential damages and Barbeques Galore's liability is limited to the purchase price of this barbecue. This warranty gives you specific legal rights, and you may also have other rights which vary from state to state. This warranty is applicable in the United States and Canada. No one else is authorized to perform any obligations under this warranty.

Barbeques Galore requires reasonable proof of your date of purchase. THEREFORE YOU SHOULD RETAIN YOUR SALES SLIP OR INVOICE AND RETURN THE BARBEQUES GALORE PRODUCT REGISTRATION CARD IMMEDIATELY.

This limited warranty shall be limited to the repair or replacement of parts which prove defective under normal use and service and which on examination shall indicate to Barbeques Galore's satisfaction they are defective. Before returning any parts to Barbeques Galore, contact our Customer Service Center by phone at (949) 597-2400 or Fax us at (949) 597-2435. If Barbeques Galore confirms the defect and approves the claim, Barbeques Galore will elect to repair or replace such part without charge. Parts returned to Barbeques Galore must be sent freight prepaid to Barbeques Galore, Inc. Customer service center 15041 Bake Parkway, Suite A, Irvine, CA. 92618 or to the nearest Barbeques Galore Store. Barbeques Galore will return parts to the purchaser freight or postage prepaid.

The LP manufacturer is solely responsible for the materials, workmanship and performance of the tank. If the tank has a defect, malfunctions, or you have questions regarding the tank, call the tank manufacturer's customer service center. The phone number is on the warning decal which is permanently attached to the tank. If the tank manufacturer has not resolved the issue to your satisfaction, then call the Barbeques Galore store nearest you.

Model Number _____ Serial Number _____

Date of Purchase _____ Purchase From _____

Refilling the Propane Gas Cylinder (Propane Units Only)

All new cylinders must be purged before the first filling.

IMPORTANT:

This barbecue is intended for use with LP cylinders equipped with a QCC-1 / OPD valve (Quick Connect Coupling Type 1 with Overfill Prevention Device).

WARNING

Purging and filling of LP-Gas cylinders must be performed by personnel who have been thoroughly trained in accepted LP-Gas industry procedures. Failure to follow this instruction may result in explosion, fire, severe personal injury, or death.

1. Turn heat control knobs and Gas Cylinder valve to "OFF" position.
2. Propane cylinder equipped with QCC-1 valve (Figure 1) is equipped with a right handed thread. Turn Black plastic nut counter-clockwise to loosen.
3. Remove cylinder from Grill. Have cylinder filled by your local Propane gas dealer.
4. Some Propane Cylinders have a bleed-off valve (Figure 1). This bleed-off valve should be inspected for leaks after each refilling of the tank. Turn clockwise to reseal.
5. Fasten full Propane tank to Grill and connect QCC-1 fitting to tank valve (Figure 1) by turning clockwise.
6. With heat control knobs still at "OFF" position, turn on Cylinder valve.

USING SOAP SOLUTION, TEST THE GAS CONNECTION FOR LEAKS. (See Page 2 for information on mixing and applying soap solution.) If bubbles appear, there is a leak; tighten or correct gas connections as necessary. After checking for leaks, turn valve off.

Assembly Instructions

1. Remove unit from carton carefully, ensuring drip tray does not fall out.
2. Check barbecue for damage.
3. Check that proper orifices are installed in the valves.

IMPORTANT: The Capt'n Cook barbecue is supplied from the factory set-up for either **Propane Gas** and fitted with **Propane Gas orifices** stamped 1.22 (Figure 2) or. **Natural Gas** and fitted with **Natural Gas orifices** stamped 2.0 (Figure 3).

The Propane Gas orifice has a substantially smaller hole size than the Natural Gas orifice and is easily distinguishable.

NOTE: Ensure barbecue is connected to the appropriate **regulated** gas supply determined by the orifices. Failure to use the appropriate gas regulator voids all warranties.

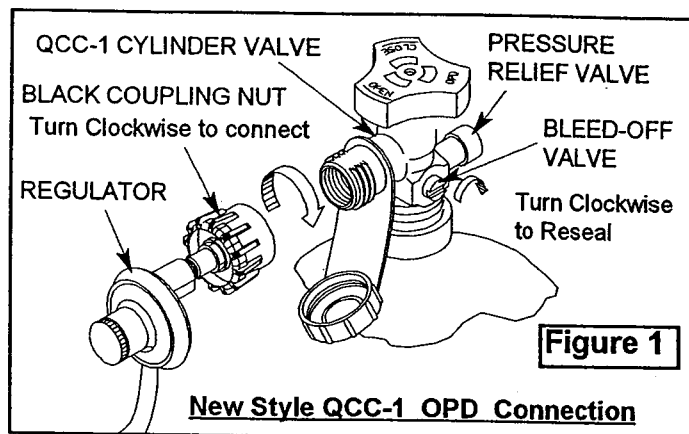

PROPANE:
stamped 1.22



Figure 2

NATURAL:
stamped 2.0



Figure 3

These Captain Cook Barbecues are NOT easily convertible and the correct model (Propane or Natural Gas) must be specified at time of purchase. A complete valve and manifold exchange is required to convert the barbecue.

Aluminum-sided Hood Installation

4. Remove the Hood Assembly from the carton carefully. The Top Hinges have been aligned and fastened to the hood section prior to delivery.
5. Place barbecue on a stable flat surface and fit the Bottom Hinges with Warming Rack Brackets on the inside of the barbecue frame using the bolts, lock washers, and nuts provided (Figure 4).

Note: The warming rack brackets **must** be fitted. Failing to fit them will result in damage to the vitreous enamel finish.

DO NOT TIGHTEN NUTS AT THIS STAGE. FINGER TIGHT IS SUFFICIENT.

6. Place the hood section onto the barbecue in the closed position being careful not to damage the vitreous enameled edges. Place the hinge pivot pins into position (you may have to move the bottom halves of the hinge assemblies to achieve alignment). Now fit the retaining clips into the hinge pivot pins.
7. Roll the assembled barbecue and hood onto its back edge ensuring that the hood does not open, and holding the front edges of the hood and barbecue with one hand, tighten the four (4) nuts, securing the hinge and warming rack bracket with the other hand (Figure 5).
8. Fit handle "D" to the front of the Hood with the Bolts provided. The recesses in the Handle should face toward you and the Bolt passes through the Handle, Spacer, and Hood and is secured with the Washer, Lock Washer and Cap Nut Provided (see Figure 6). **DO NOT OVER-TIGHTEN.**
9. Fit the two Plastic Plugs into the Handle to cover the bolt heads.

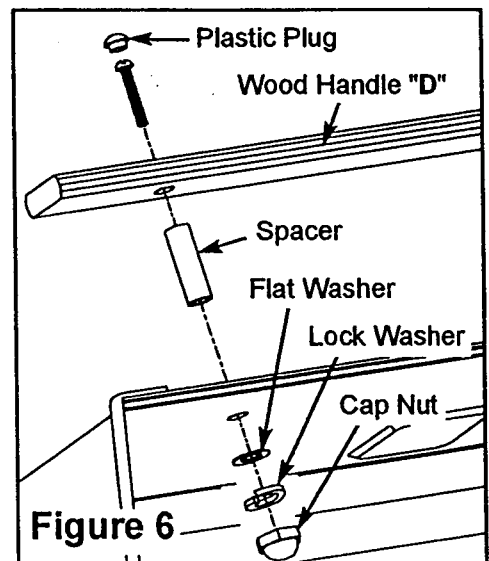
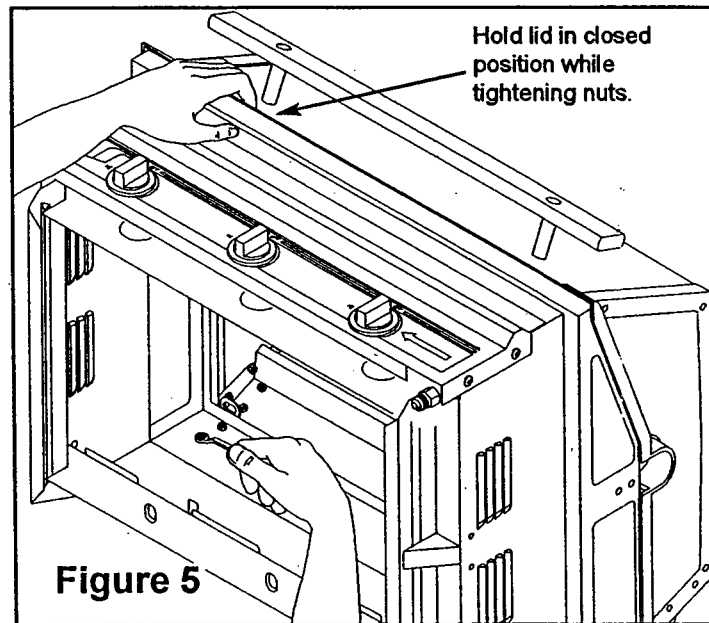
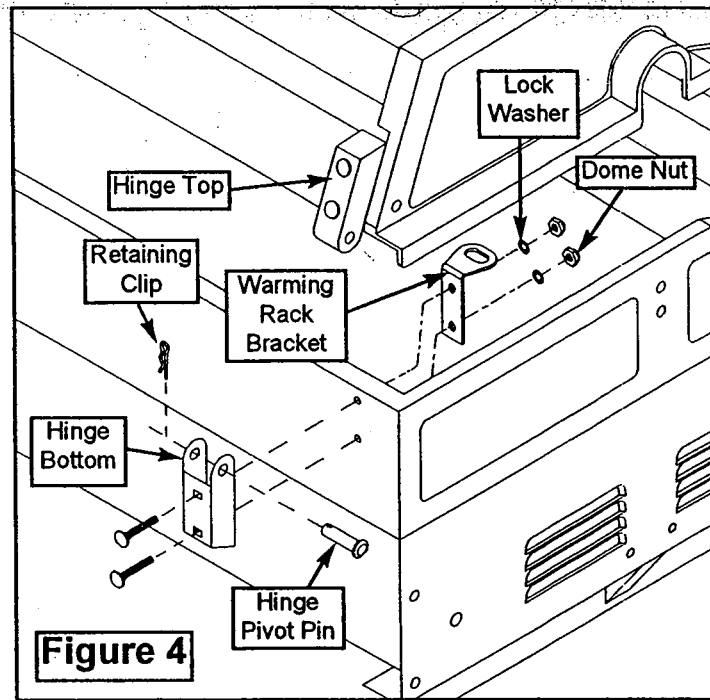

Installing & Seasoning Cast Iron Burners

10. This Gas Grill must be connected to an appropriate REGULATED gas supply - refer to Safety Information.
11. Remove Drip Tray from packaging carefully. We recommend that you fill the drip tray with sand or Fat Soak, approximately ¼" deep, prior to using the grill initially, as this will help absorb any grease or residues from the barbecuing process. Change the sand on a regular basis.

TIP:- For easier clean up, line the grease tray with heavy duty foil (shiny side down) and then cover with ¼" of sand.

IMPORTANT: PORCELAIN COATED BURNERS DO NOT HAVE TO BE SEASONED- Do NOT perform steps 13, 15, 16 & 17 on PORCELAIN COATED Burners.

NOTE: You must NEVER use just foil, as the reflected heat will be excessive and could damage the barbecue - it must be covered with ¼" of sand.

12. Remove the cast iron burners from packaging.
13. Coat each burner lightly with any vegetable cooking oil.
14. Place burners into Barbecue. The open end of the burner has to be installed over brass stem of valve (Figure 7) and then the rear of the burner is lowered down onto the back bracket locating the cast peg into the appropriate hole.

Note: Air Adjustment - The bolt on the side of each burner should be screwed all the way in and secured with the locking nut prior to installation.

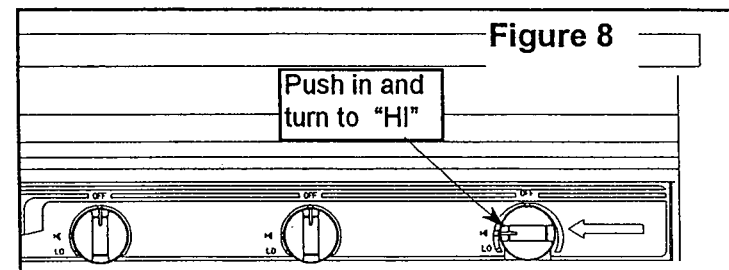
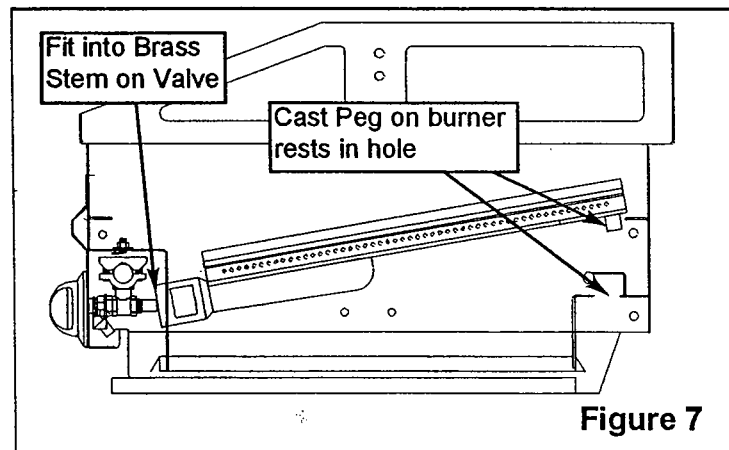

15. Light the grill per instructions on page 7.
IMPORTANT!: Lid must be in open position when lighting.
16. As each burner is lit, position each knob between Medium and High for 10 minutes maximum.

Note: During this process the Rock Grate and Cooking Grills must not be installed and the Hood should be left open.

17. Turn burners OFF. Allow Cast Iron Burners to cool completely and then lightly brush with vegetable oil again. Burners are now seasoned.

18. Remove the Deluxe Cast Iron Rock Grates from carton and install them into the barbecue above the Cast Iron Burners, ensuring they rest on top of the support tags. (Figure 9)

Note: The front side of the Cast Iron Rock Grate must be installed first and then lowered down onto the back support tags.

19. Place the Ceramic Rocks on top of the Rock Grate in correct position (Figure 10).
 20. Place the Porcelain cast iron cooking surfaces in position (Figure 12).
- Tip:** - A light coating of vegetable oil will prevent food from sticking to the grills.

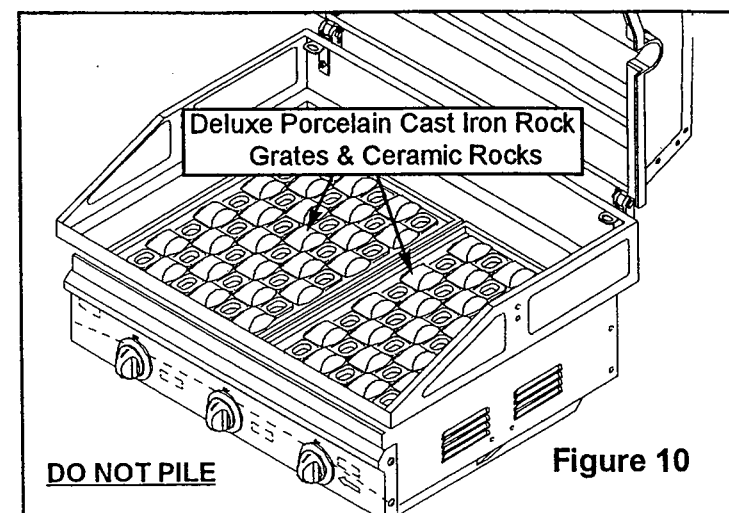
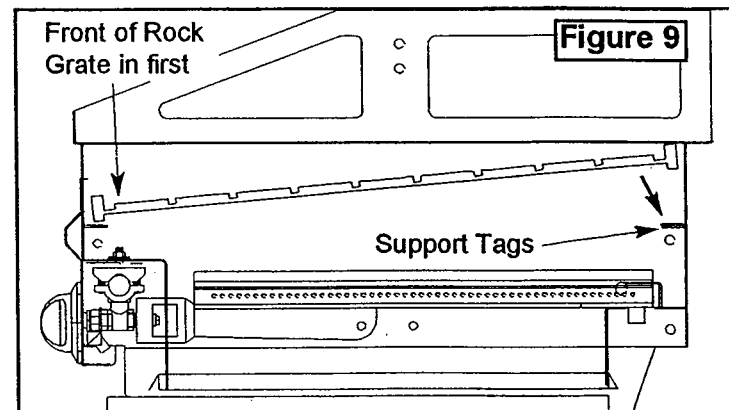

USING YOUR GAS GRILL

Location

THE GAS GRILL IS DESIGNED FOR OUTDOOR INSTALLATION ONLY.

It may be installed on a covered or open patio provided the sides and bottom are at least 14" away and the back at least 16" away from any combustible construction. The grill must not be located under any overhead unprotected combustible construction.

Before each use, carefully and thoroughly check regulator hose. If it is evident there is excessive abrasion or wear, or the hose is cut, it must be replaced prior to the appliance being put into operation. Contact your BBQ Galore retailer or by calling BBQ's Galore at (949) 597-2400.

Lighting Instructions:

Important: Do not bend directly over grill when lighting the burner. Lid must be in open position before lighting.

Pilot flame ignition on ALL burners:

Push in knob and turn slowly (counterclockwise) through ignition position to "HIGH". If burner does not light return to "OFF" position and repeat. If it fails to light again, turn the control to "OFF". Wait 5 minutes for any accumulated gas to clear out of the grill.

Pilot flame ignition on right hand burner only:

Push Right Hand Knob in and turn slowly (counterclockwise) to HI. If Right Hand Burner does not light, turn knob to "OFF" position and repeat.

If it fails to light again, turn the control to "OFF" position and wait 5 minutes for any accumulated gas to clear out of the grill.

Once the right burner is lit, the burner next to it can be turned on and it will light off the lighted burner.

If the knob is turned fully counterclockwise the lowest flame setting will occur. To visually check that the burner is operating look between the frame and tray at the flame. The flame should be approximately 1/2"-3/4" long with the high setting (see Figure 16).

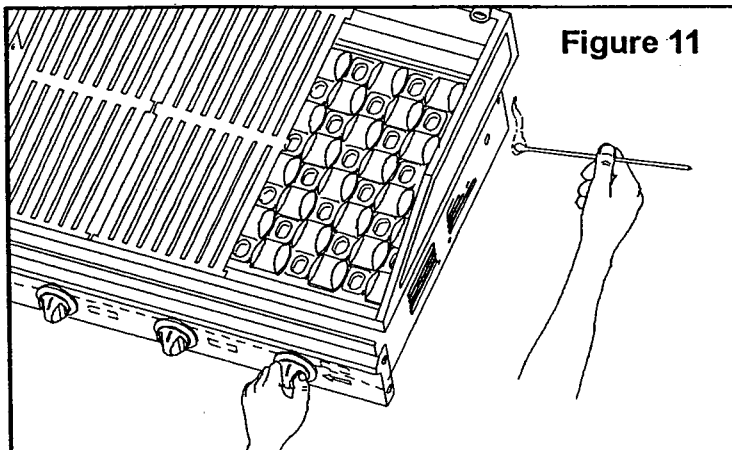

Figure 11

NOTE: If Grill does not light with the Igniter, use a long match as shown in Figure 11

Shutting Your Grill Down

After you have finished using the Gas grill turn all knobs to the OFF position. Close the valve on the gas supply.

Preheating the Grill

Light the burners as previously directed and turn to high and allow the grill to preheat for 5 minutes maximum. If the unit is equipped with a smoker hood, lower the lid during this preheating period.

Heat Control

IMPORTANT: When cooking with hood closed, never exceed temperatures of 480°F (250°C).

Direct Cooking: Your Gas grill is equipped with a number of burners which can be regulated easily. This feature gives you the flexibility to cook enough hamburgers to feed the whole gang with all the burners at the same setting, or slow cook a casserole over low heat on one side of the grill while you sear a steak over a high flame on the other side, or just light one or two of the burners for a small meal.

Indirect Cooking: Cook large cuts of meat to golden perfection with indirect heat. (Grill must be equipped with smoker hood.). By using indirect heat, your food doesn't come in direct contact with flame, instead, the heat from the lighted side of the grill gently circulates throughout the grill. Cooking food above the unlighted burners with indirect heat (Fig. 13).

Closed Hood Saves Money

When the smoker hood is closed you have a more con-

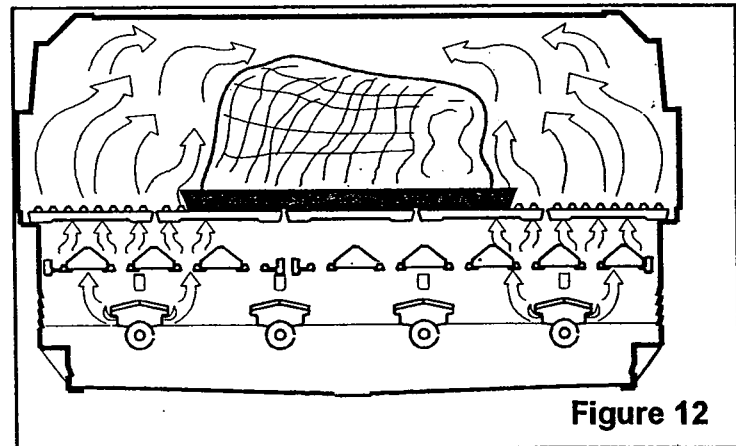

Figure 12

stant temperature. Your food will cook faster, with fewer flare-ups, and you will use less energy. Always use a drip tray when cooking roasts, whole fish, chickens and ALL rotisserie cooking (see Figure 15). Use of a drip tray eliminates basting, since the juices drop into the drip pan, vaporize, rise and self-baste. Water, beer, wine, fruit juices or herbs in the drip pan adds flavor. Gravy or sauce can be made from the drippings. Disposable drip pans prevent flare-ups.

Flare-up Control

Anytime you cook meat above an open flame you will have flare-ups, since flare-ups are caused when the natural juices from the meat fall on the ceramic rock. Flare-ups, and the resulting smoke, are what give meat cooked over an open flame the delicious outdoor flavor, so expect and encourage some flare-up.

However, excessive flare-ups can be caused by cooking extra fatty foods directly on the grill, or by cooking with too high a temperature. These types of flare-ups should be controlled or your food will burn.

To prevent excessive flare-ups, trim off excess fat from meat and poultry before putting it on the grill, or cook particularly fatty meat such as duck, in a foil tray (or put the foil tray on the lava rocks directly under the meat). To control excessive flare-ups caused by too high a heat setting, turn the heat control knob to a lower setting.

Cleaning Up After Using Your Grill

To keep your grill ready for the next time you want to use it, turn the grill off, then take a long handled soft brass bristle brush and brush off the cooking grills. Be careful, they're hot! Protect your hand from the heat by using an oven mitt to hold the brush.

Getting To Know Your Gas Grill & Smoker Hood

1. **Hood Handle:** Mounted on front to make opening and closing the hood easier.
2. **Heat Indicator:** Indicates the temperature inside the hood. Invaluable when cooking by indirect heat and smoking.
3. **Smoker Hood:** Converts your gas grill into a smoker oven by keeping the smoke and heat in. Try to keep it closed at all times when grilling too, as it conserves energy, saves money, minimizes flare-ups and improves flavor.
4. **Optional Rotisserie:** The Rotisserie is equipped with a heavy duty motor to turn the solid rotisserie rod.
5. **Automatic Igniter:** The ignition system is incorporated within the control valve. Refer to lighting instructions on page 7.
6. **Heat Control Knob:** Each heat control knob has infinite settings for complete cooking flexibility. As a safety precaution, knob has been designed so that it must be **PUSHED IN AND ROTATED COUNTERCLOCKWISE** in order to turn the gas on.
7. **Drip Tray:** Fill drip tray with Fat Soak. Fit heat shield (if supplied) making sure edge of heat shield sits into and not on top of sand on tray base (see Page 14). This full width tray is designed to catch all the fat, etc., which is not burnt off. It is advisable to fill with sand or Fat Soak, approximately 1/4" deep, prior to using the grill initially as this will assist cleaning it out when required. For easier clean up, line the grease tray with Heavy Duty foil (shiny side down) - then you **MUST** cover the foil with 1/4" sand. **DO NOT USE FOIL ONLY - IT MUST BE COVERED WITH SAND.**
8. **Flame Tamers:** The Cast Iron Rock Grate together with the Ceramic Rocks absorb & radiate heat from the burners evenly throughout the cooking area.

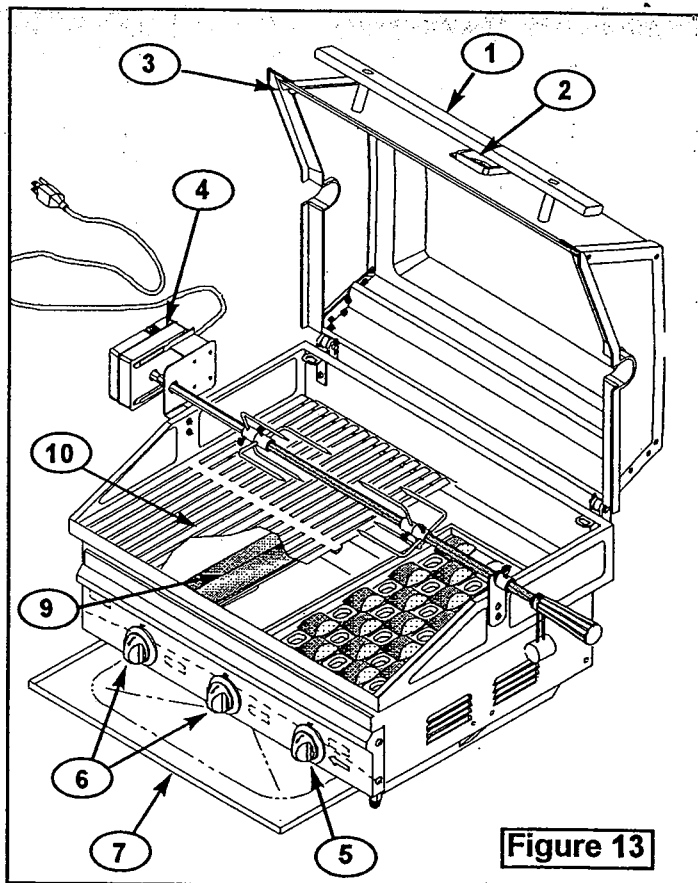

Figure 13

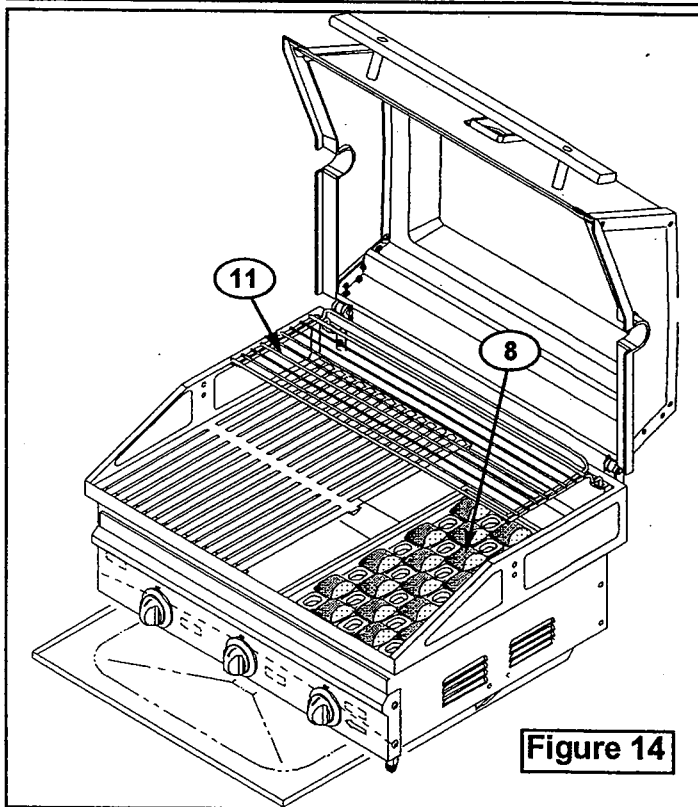
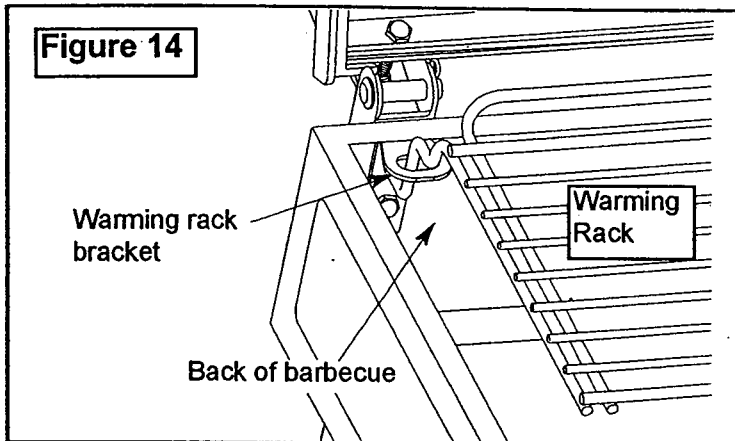

Figure 14

9. **Cast Iron Burners:** The specially designed cast iron burners are designed to give an even spread of heat throughout the entire length to give perfect cooking results every time.

- Cooking Grills:** These solid cast iron porcelain coated grills have a uniform heated cooking surface to sear your steak to perfection. It may be necessary to remove grills if the rotisserie is used to gain greater depth (see Figure 16).
- Warming Rack:** Designed to keep your food warm



while you finish cooking. **NOTE:** Warming Rack must be removed when a Rotisserie is used (see Figure 16)

NOTE: When installing Warming Rack, make sure back legs fit into warming rack bracket holes and rest against the back of the barbecue frame (see Figure 15).

Cleaning

The barbecue has been designed and manufactured from heavy gauge porcelain steel for long life, just like an oven. If cleaning is necessary, please use a soft damp cloth and some household detergent. refer to Maintenance Instructions.

Cooking Tips & Care of your Gas Grill

Food Preparation

Preparing food to be cooked on your gas grill requires no more effort than if you were preparing it to be cooked on your indoor range. The following tips will help you get the best results right from the start.

- Trim off excess fat from meat, leaving a thin strip round the edges. To prevent meat from curling up while it cooks, slash the remaining fat at two-inch intervals, taking care not to cut into the meat. Trim off all excess fat from poultry before cooking
- Use tongs instead of a fork when turning meat or poultry. The prongs of a fork pierce the meat or poultry, causing it to lose it's natural juices.
- If you use a tomato or sugar base sauce for basting, do not apply until the last five or ten minutes of cooking period. Use over a longer period of time will result in over-browning or charring.
- Poultry, fish and natural lean meats should be brushed with cooking oil, butter, or margarine several times during the cooking period to avoid their drying out.

- Meats and poultry should be brought to room temperature before cooking. Frozen foods such as fish and vegetables should be put on the grill without thawing.
- Salt meat, fish or poultry after cooking not before or during cooking periods. Salt tends to draw the natural moisture out of food, causing it to dry out. Other spices including pepper and garlic may be freely applied.

Smoke Cooking

Smoke cooking is an exceptionally slow method of cooking in which a flavoring source is added to the ceramic rocks in order to impart its own delectable flavor to the meal for a deep smoke flavor, soak a flavoring source such as hickory chips, green twigs of apple-wood or wild cherry, garlic cloves or bay leaves in water for 30 minutes prior to use. Loosely wrap in a single layer of aluminum foil, leaving one end slightly open or place on the ceramic rocks at the beginning of the cooking period. For a lighter smoke flavor, add the pre-moistened wrapped flavor source to the ceramic rocks during the last half hour of the cooking period.

Remember smoke cooking is slow cooking. You can't hurry it along without unsatisfactory results. Keep the heat control knobs set at LOW and the lid closed.

Rotisserie Cooking

A rotisserie is mostly used to cook large pieces of meat and poultry to assure slow, even cooking. The constant turning provides a self-basting action, making food cooked on a rotisserie exceptionally moist and juicy.

Since indirect heat is often used in cooking on a rotisserie, a foil or aluminum drip pan is advisable to prevent excessive

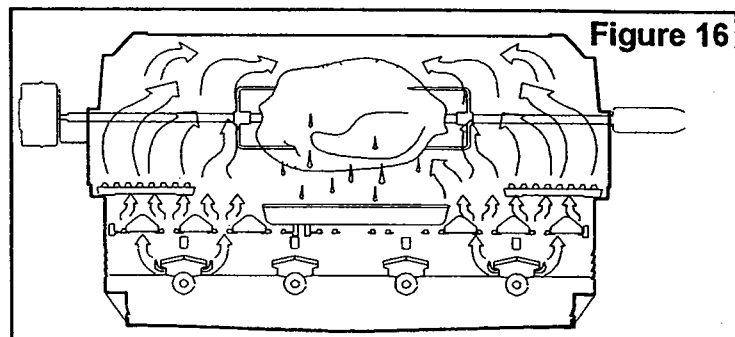

flare-ups. Push aside the lava rocks underneath the meat so that the drip pan rests directly on Rock Grate. Pan can be emptied with a bulb baster (Figure 16).

For successful rotisseriesing, the meat should be centered and balanced as evenly as possible on the spit rod to avoid overworking the rotisserie motor. Center meat on spit, then secure in place with the fork-like skewers. Test the loaded spit for proper balance by supporting both ends in your palms. Roll spit; if spit does not turn easily, the meat is not properly balanced and will need to be repositioned. If your food isn't balanced, use the Counterbalance to correct this condition to assure trouble-free rotisserie cooking by always maintaining the perfect balance, see Figure 13.

Remember, keep lid closed and operate burner on LOW when rotisseriesing.

DO'S & DON'TS

DO..

- Have propane cylinder (LP units) filled by authorized LP supplier.
- Record your grill model number on your instructions and keep the instructions and parts list in a convenient place.
- Check all gas line connections for leaks with soapy solution prior to lighting, tighten until bubbles disappear.
- Raise the hood before lighting the burner.
- Preheat the grill 5 minutes maximum before cooking.
- After cooking, turn the grill off, then take a long handled soft brass bristle brush and brush off the cooking grills. Then turn off gas at the Propane tank or main valve.
- Use a mitt to turn off tank valve, it can get hot.
- Cook with hood down when possible. It is generally faster and more efficient. Trapped smoke adds to the flavor.
- Turn the gas off promptly should you be unable to light the grill immediately. Wait a full 5 minutes before attempting to light grill again.
- Have proper tools, tongs, mittens and hot pads ready prior to removing foods.
- Trim excess fats from meats to minimize flare-ups.
- Let the grill cool before removing any parts for cleaning.
- Be careful of the control valve setting. LP gas is hotter and the lower setting may be generally preferred.
- Cover the barbecue when not in use.
- Use a mitt or glove when opening BBQ lid.

DON'T..

- Install grill closer than 14" on the sides or 16" on the back to any combustible construction.
- Attempt any adjustment of the regulator, it has been preset and tested.
- Allow the LP tank to lie on its side. Keep in an upright position.
- Turn a control knob on until a lighted match is inserted in the lighting hole.
- Use plastics or untempered glass utensils on the grill.
- Attempt to move an aluminum foil pan while it is hot. Let it cool first before moving it.
- Cover or block any air openings in the bottom of the grill with foil.
- Wear long, loose flowing clothing around the grill. Long flowing hair is also easily ignited especially by unexpected flare-ups. Tie hair back or wear a hat or a scarf.
- Put food on the grill and leave it unattended or unwatched for long periods. Most fats can catch fire even on the lower setting.
- Clean Flame Tamers in any solution other than a boiling detergent water. Then rinse well, dry and reuse.
- Use caustic materials, i.e., lye, to clean grill parts.
- store any additional Propane gas tanks under barbecue
- Season cast iron burners.
- ⚠ Jarrah Cart not intended for commercial use.
- ⚠ When cooking with hood closed NEVER exceed temperatures of 480°F (250°C).

WOOD CHIPS IN A GAS GRILL

Wood chips should be soaked for a minimum of 30 minutes. Presoaked chips or chunks may be thrown directly onto a charcoal fire, but they must be in a container or wrapped in foil, log fashion, for use in gas grills.

If smoking is expected to last for a long period of time, you should keep chips soaking in the event you need to throw more on the fire or to add to the container or make another foil log.



ENERGY CONSERVATION

You'll be pleased to know that by cooking outdoors on your Gas grill you'll be using no more of our nation's precious energy than if you were cooking indoors. And, on hot summer days, cooking outdoors takes the heat out of the kitchen and cuts down on the energy needed to air condition your home.

MAINTENANCE GUIDE

On at least a monthly basis during times when the BBQ is in use, and at least every other week during high usage periods, the following items must be inspected:

1. Clear the area surrounding the BBQ of ALL combustible materials, gasoline and other flammable vapors and liquids.
2. Insure that the free flow of combustion and ventilating air is not obstructed.
3. Cast iron burners should be wire brushed and coated with cooking oil every 3 months (Do not use oil on Porcelainized Coated Burners).

Cooking Grills: The Porcelain Cooking Grills should be cleaned regularly. Use a brass bristle brush to lightly clean off the excess build-up on both sides of the grill. Use care not to scratch or chip the porcelain finish. Do not use abrasives!

To thoroughly clean the grills:

Step 1. Lightly brush off excess build-up with brass brush on both sides.

Step 2. Remove grills from BBQ.

Step 3. Wash grills in warm water.

Step 4. With grills still wet, sprinkle baking soda very liberally over surfaces on both sides.

Step 5. Take a wet sponge and vigorously rub and clean off surfaces.

NOTE: Tough spots may need second application of baking soda and rubbing.

Step 6: Rinse well and dry. Oil lightly.

Cast Iron Burners: Burners need to be cleaned periodically. Take each individual burner out of the BBQ and brush it down very thoroughly using a stiff wire brush (Use care on Porcelainized Coated Burners - do not damage enamel coating). Make sure every port hole is open. If the holes are obstructed, they may be cleaned using an open paper clip or small drill bit (#31 drill size) on a drill.

Use a fine tooth hacksaw blade or sharp knife to clean out cross over slot on bottom of burner. Tap the open end of burner gently on a hard surface to dislodge any rust, etc. inside.

To visually check that the burner is operating, look at the burner flame between the tray and BBQ frame. The flame should be approximately 1/2"-3/4" long with the high setting (see Figure 17).

Cast Iron Burners ONLY - Do not season Porcelainized Coated Burners.

After thorough cleaning, it is recommended that the Cast Iron Burners are "Seasoned" again (see page 6) *TIP: Rotate the burners every few months.*

A Venturi Tube Cleaner should be used to clean the venturi section.

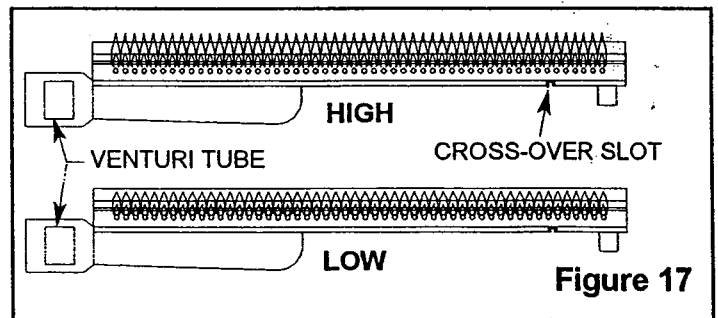

Hood: The Hood should be periodically cleaned as, over time, the material (baked-on grease) inside the Hood will appear to be flaking off. This is residue only and can be cleaned using Simple Green Barbecue Cleaner. The unit has a Porcelain Enamel Finish, exactly like an oven and in extreme cases an oven cleaner can be used...rinse well.

Note: Baking Soda is an ideal cleaner.

Note: Do not use abrasives on any porcelain finish.

INFORMATION REGARDING REPLACEMENT PARTS

Replacement parts for this barbecue unit are available from your Barbeques Galore retailer or if you have any questions call your friends at Barbeques Galore: phone #(800) GRILL UP.



America's Largest Chain of Barbecue Stores

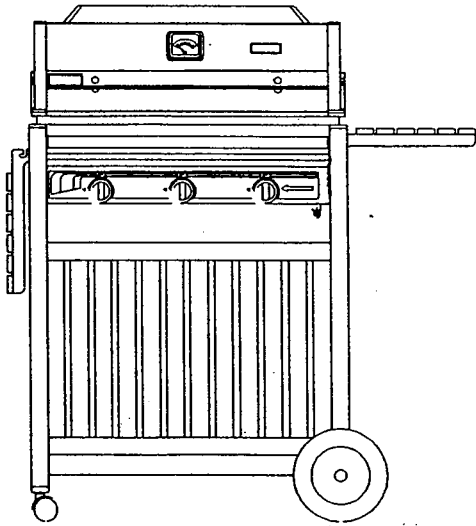

105520 Deluxe Steel Cart for 3 Burner
105560 Deluxe Steel Cart for 4 Burner
105595 Deluxe Steel Cart for 5 Burner

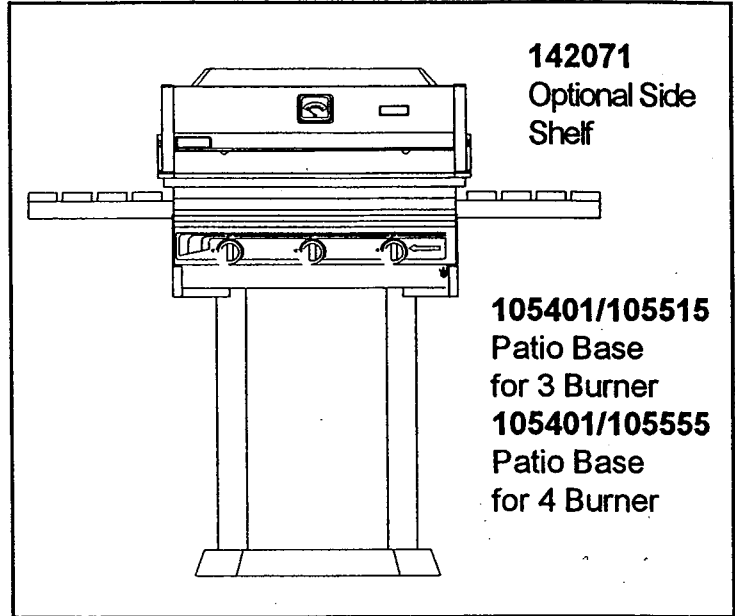

142071
 Optional Side Shelf

105401/105515
 Patio Base
 for 3 Burner
105401/105555
 Patio Base
 for 4 Burner

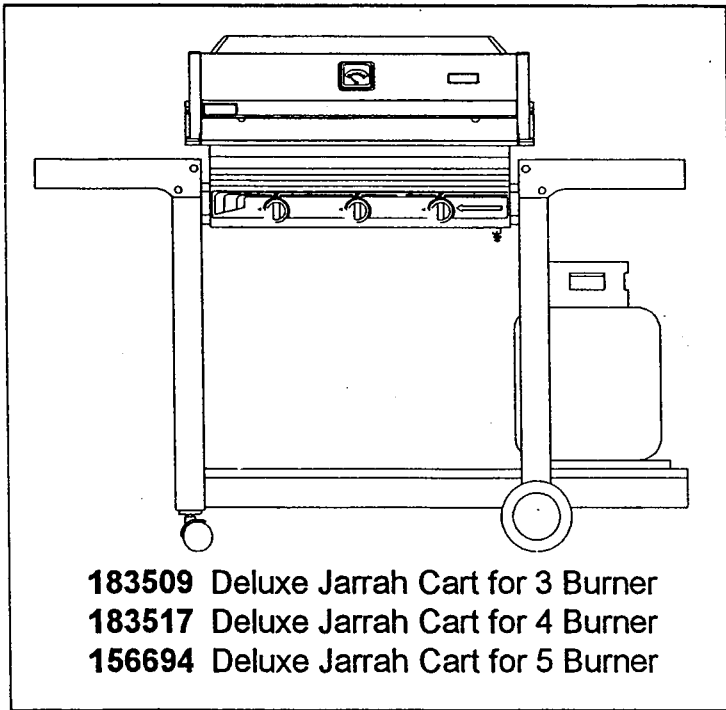

183509 Deluxe Jarrah Cart for 3 Burner
183517 Deluxe Jarrah Cart for 4 Burner
156694 Deluxe Jarrah Cart for 5 Burner

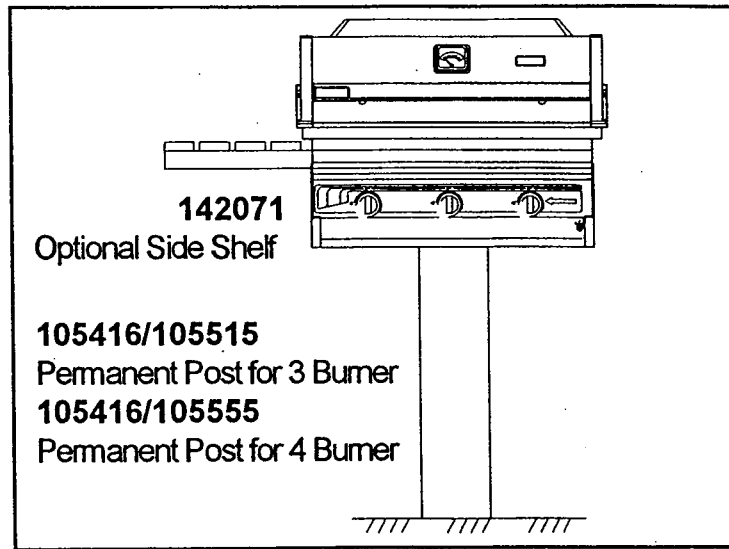

142071
 Optional Side Shelf

105416/105515
 Permanent Post for 3 Burner
105416/105555
 Permanent Post for 4 Burner

#SKU	#195172	#195412	#195180	#195420	#195198	#195438	Bill of Material for Capt'n Cook Barbecues	
MODEL	XG3CKW	XG3CKWN	XG4CKW	XG4CKWN	XG5CKW	XG5CKWN	SKU#	DESCRIPTION
ITEM	QTY	QTY	QTY	QTY	QTY	QTY		
1	1	1					161410	"G" Frame - 3 Burner Black
2			1	1			161425	"G" Frame - 4 Burner Black
3					1	1	161430	"G" Frame - 5 Burner Black
4	1	1					196733	Front Panel S/S (no decal) - 3 Brnr Capt'n Cook
5			1	1			196741	Front Panel S/S (no decal) - 4 Burner Capt'n Cook
6					1	1	196758	Front Panel S/S (no decal) - 5 Burner Capt'n Cook
7	1	1					196766	Decal - S/Steel 3 Burner Capt'n Cook
8			1	1			196774	Decal - S/Steel 4 Burner Capt'n Cook
9					1	1	196782	Decal - S/Steel 5 Burner Capt'n Cook
10	3	3	4	4	5	5	206045	Control Knob - Capt'n Cook
11	1	1					104897	Drip Tray Porcelainized - 3 Burner
12			1	1			104901	Drip Tray Porcelainized - 4 Burner
13					1	1	104916	Drip Tray Porcelainized - 5 Burner
14		3		4		5	195966	90° Flame Throw Valve - Natural Gas
15	2	2	3	3	4	4	100248	90° Valve Assembly (optional)
16	1	1					155332	Manifold - suit 3 Burner Flat Face "G" Frame
17			1	1			155347	Manifold - suit 4 Burner Flat Face "G" Frame
18					1	1	162158	Manifold - suit 5 Burner Flat Face "G" Frame
19	3		4		5		195974	90° Flame Throw Valve - Propane
20		3		4		5	125791	Orifice - Natural Gas
21	3		4		5		125726	Orifice - Propane
22	1	1					112306	Rock Grate - 3 Burner (Alternate)
23			1	1			112311	Rock Grate - 4 Burner (Alternate)
24					1	1	112326	Rock Grate - 5 Burner (Alternate)
25	2	2	2	2	3	3	124840	Lava Rock (Alternate)
26	3	3	4	4	5	5	196048	Burner Porcelain Cast Iron
27	2	2					143610	Cooking Grill - 13" Standard Porcelain
28			4	4	5	5	143605	Cooking Grill - 8" Standard Porcelain
29	1	1	1	1	1	1	161485	Side Panel - Left (Style 3)
30	1	1	1	1	1	1	161490	Side Panel - Right (Style 3)
31	1	1					161504	Back Panel - 3 Burner (Style 3)
32			1	1			161519	Back Panel - 4 Burner (Style 3)
33					1	1	161524	Back Panel - 5 Burner (Style 3)
34	1	1					172414	Shroud, Maroon - 3 Burner (Style 3)
35			1	1			172429	Shroud, Maroon - 4 Burner (Style 3)
36					1	1	195263	Shroud, Maroon - 5 Burner (Style 3)
37	1	1					126444	Handle - 3 Burner
38			1	1			127805	Handle - 4 Burner
39					1	1	130087	Handle - 5 Burner
40	2	2	2	2	2	2	155169	Handle Spacer
41	2	2	2	2	2	2	155149	Bolt Assembly for Handle
42	2	2	2	2	2	2	155154	Plastic Cap
43	1	1	1	1	1	1	161564	Barbeques Galore Badge
44	1	1	1	1	1	1	161579	Hood Hardware Pack Assembly (Style 3)
45	1	1	1	1	1	1	120776	Hood Thermometer
46	2	2	2	2	2	2	161450	Hinge Top
47	2	2	2	2	2	2	161465	Hinge Bottom
48	2	2	2	2	2	2	161470	Warming Rack Bracket
49	2	2	2	2	2	2	161599	Retaining Clip (Style 3)
50	2	2	2	2	2	2	161584	Hinge Pivot Pin (Style 3)
51	1	1					161603	Crossfire - Stainless Steel 3 Burner
52			1	1			161618	Crossfire - Stainless Steel 4 Burner
53					1	1	161623	Crossfire - Stainless Steel 5 Burner
54	1	1	1	1	1	1	163207	Lighting Instruction Decal
55	2	2	2	2	2	2	162772	Hood Buffer
56	2	2	2	2	2	2	163133	Clip for Crossfire
57	8	8	8	8	8	8	183434	S/Steel Bolts for S/Steel Hinges
58	1	1					171330	26" Warming Rack - Porcelainized
59			1	1			172197	31" Warming Rack - Porcelainized
60					1	1	196071	39" Warming Rack - Porcelainized
61	4	4	4	4	4	4	161876	Stainless Steel Flat Washer - Black
62	8	8	8	8	8	8	161881	Lock Washer #10 - Zinc
63	8	8	8	8	8	8	196063	Dome Nut
64	2	2	1	1			144170	12" Cast Iron Rock Grate
65			1	1	2	2	112272	18" Cast Iron Rock Grate
66	2	2	1	1			144190	30 piece Ceramic Rock
67			1	1	2	2	144204	50 piece Ceramic Rock
68	3	3	4	4	5	5	187070	Bezel, Chrome

3 Burner Capt'n Cook

Model #XG3CKWA, Sku# 195172

Model #XG3CKWAN, Sku# 195412

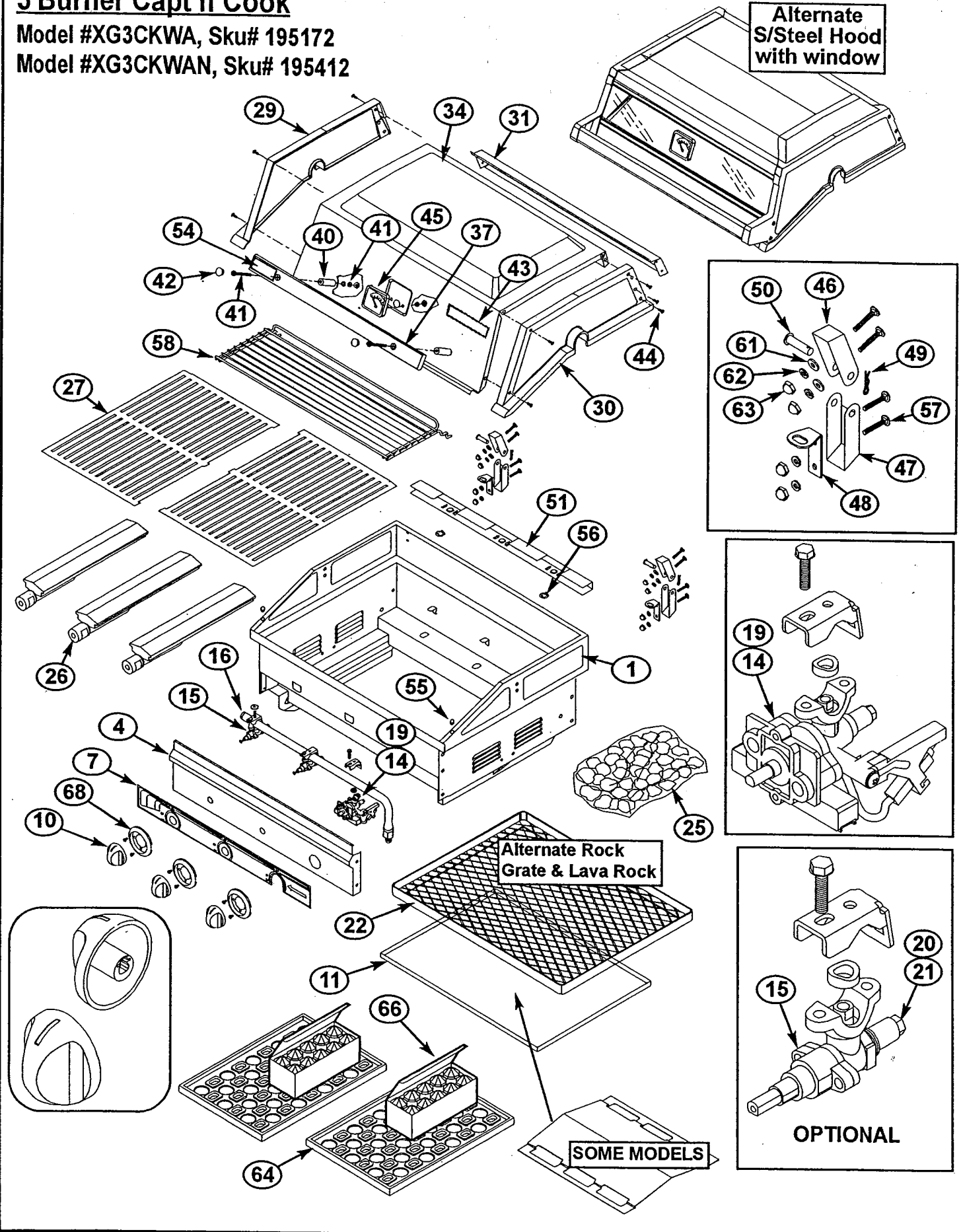

4 Burner Capt'n Cook

Model #XG4CKWA, Sku# 195180

Model #XG4CKWAN, Sku# 195420

