

This Owner's Manual is provided and hosted by [Appliance Factory Parts](#).



Rexair D2 Owner's Manual

[Shop genuine replacement parts for Rexair D2](#)



[Find Your Rexair Vacuum Cleaner Parts - Select From 21 Models](#)

----- Manual continues below -----

REXAIR Original

Model D2

Start Date 1960

Figure A

Cap & Baffle Ass'y

KEY	PART NO.	DESCRIPTION
1	NLA	Handle
2	NLA	Rainbow Disc
3	R-2939	Cap Only (Replaces R-640)
4	NLA	Cap Insulation
5	NLA	Screw, Sheet Metal
6	NLA	Baffle Ass'y
7	R-H451	Hi-Lo Screw
8	NLA	Speed Nut
9	NLA	Gasket, Closure Cover
10	NLA	Closure Ass'y

Figure A

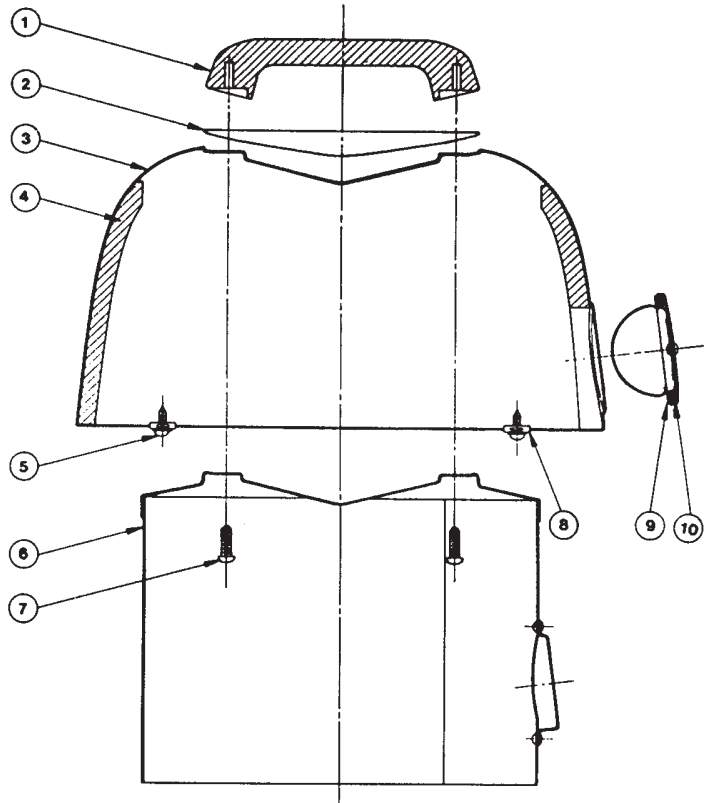
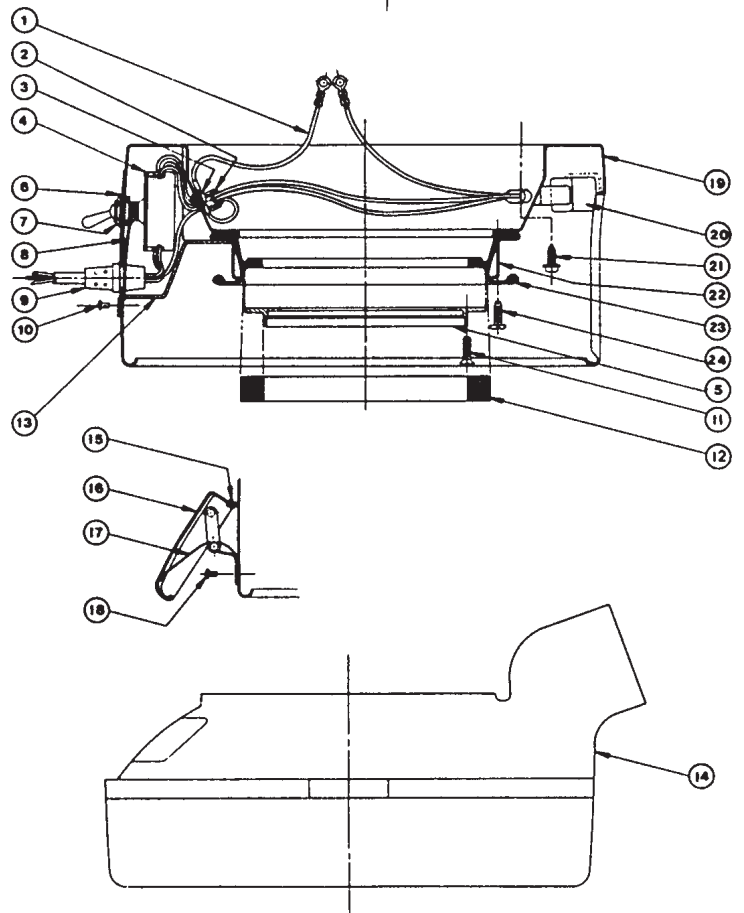

Figure B

Main Housing Sub Ass'y & Water Pan

KEY	PART NO.	DESCRIPTION
	NLA	Main Housing Sub Ass'y
1	R-1848	Ground Lead Ass'y
2	R-1158	Open/Close Bushing
3	R-H25	Lockwasher Screw
4	R-625	Switch Ass'y
5	R-747	Motor Gasket Flange
6	NLA	Washer
7	R-408	Hex Nut (Included with R-625)
8	NLA	Strain Relief Support
9	R-1030	Electric Cord (3 Wire)
10	NLA	Rivet
11	R-H378	Machine Screw
12	R-912	Motor Gasket
13	R-750	Switch Cover
14	NLA	Water Pan
15	NLA	Fastener Bumper
16	NLA	Fastener Ass'y
17	NLA	Fastener Spring
18	R-H303	Rivet
19	R-1279	Main Housing Only
20	R-1761	Receptacle Ass'y (3 Wire)
21	NLA	Sheet Metal Screw
22	R-598	Outer Clamp Ring
23	R-599	Motor Support Ring
24	NLA	Sheet Metal Screw

Figure B



NLA = No Longer Available

REXAIR Original

Model D2A Motor Assembly R-1405

Three Conductor Sealed By-Pass Motor

Replace with R-2104

KEY	PART NO.	DESCRIPTION
1	R-1423	Stage Housing Clip
2	R-1419	Stage Ass'y
3	R-1418	Air Guide
4	R-1411	Bearing Plate Ass'y
5	R-665	Grommet
6	R-1853	Terminal, Insulated
7	R-H487	Cable Clamp
8	NLA	Field Ass'y
9	R-1454	Field Insulator
10	R-1426*	Armature Ass'y
11	R-1180	Ball Bearing
12	R-147	Slinger Ring
13	R-146	Bearing Shield
14	R-H306	Shaft Nut
15	R-1486	Spacer
16	R-1421	Stage Ass'y, Upper
17	NLA	Fan Spacer, Middle
18	R-675	Fan Ass'y
19	R-1416	Fan Spacer, Lower
20	R-H475	Screw, Bearing Plate
21	R-1415	Gasket, Bearing Plate
22	R-1469	Fan, Armature Cooling
23	R-H474	Screw, Motor Field
24	R-1578	Terminal, Brush Flag
25	R-1455	Gasket, Brush Holder
26	NLA	Brush & Holder Kit
27	R-H309	Screw, Brush Holder
28	R-1552	Carbon Brush & Spring
29	NLA	Screw Cap
30	R-1448	Motor Housing
31	R-1449	Insulator, Fld. Scr. Insert
32	R-1424	Air Deflector
33	R-H308	Screw, Lower Bearing
34	R-1425	Spider
35	R-H13	Shaft Nut
36	NLA***	Separator, Low Profile
	RR-6250	Separator, All Models
		Prior To D4C, D4CSE
37	R-3450	Separator Screw
38	R-1752	Stage Ass'y (Lower w/Grid)
39	R-1473	Retainer, Cover Plate
40	R-1471	Cover Plate
41	R-1470	Gasket, Cover Plate
42	R-1794	Gasket, Upper Shell
43	R-1407	Shell Motor Housing
44	R-1795	Gasket, Lower Shell

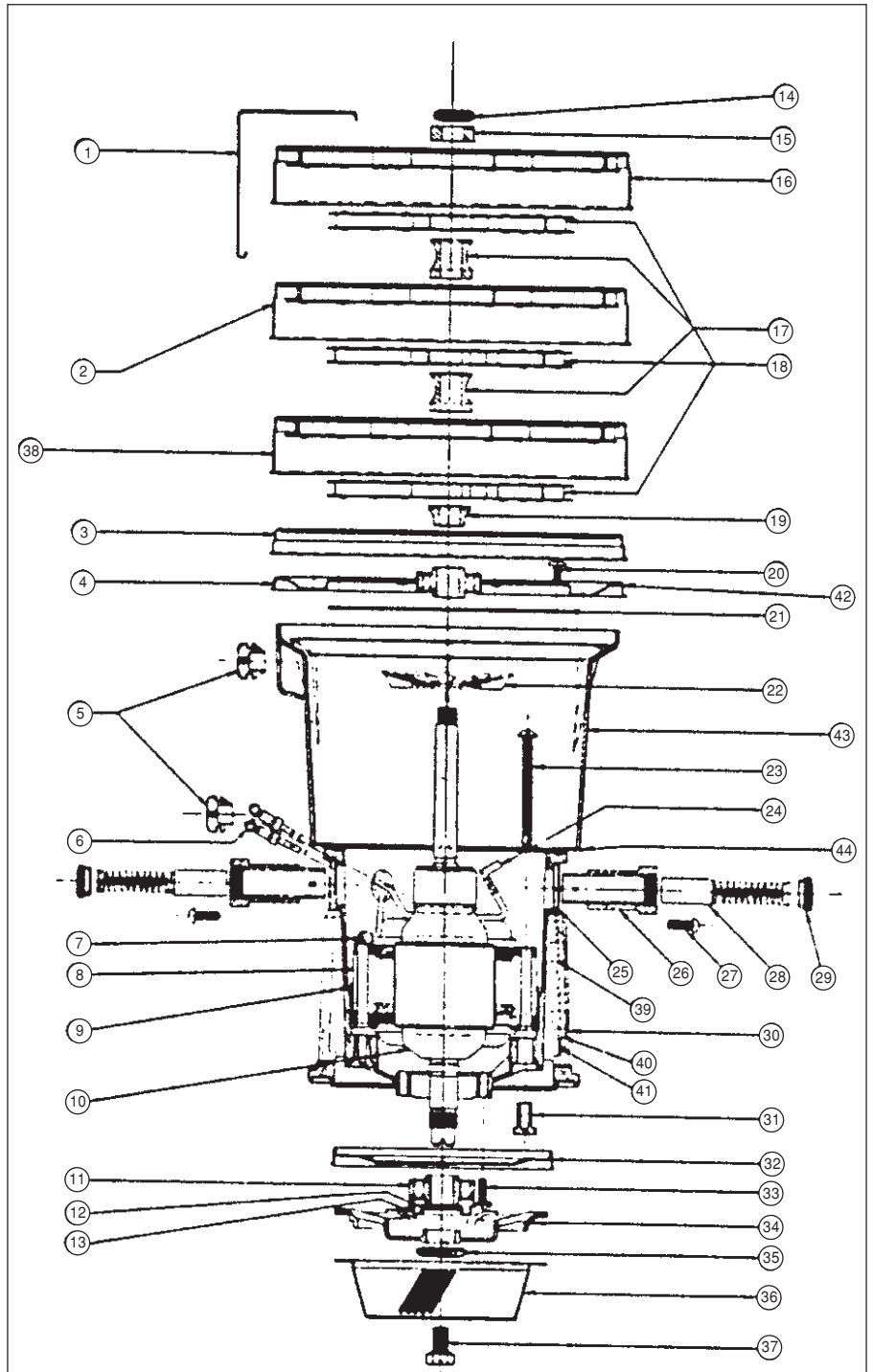

*ARMATURE NOTE:

R-692 ARMATURE FITS: D2 WITH R-1395 MOTOR
 R-1426 ARMATURE FITS: D2A-D3C WITH
 R-1405 MOTOR - FROM SN. 4388126
 R-1909 ARMATURE FITS: D2-D3C WITH
 R-1767 MOTOR FROM SN. 4545550
 R-1974 ARMATURE FITS: D2-D3C WITH
 R-2104 MOTOR FROM SN. 46072000

*** THE R-312 LOW PROFILE SEPARATOR AND R-1976
 SPIDER ARE NO LONGER AVAILABLE FROM REXAIR.
 WHEN REPLACING THE SEPARATOR OR SPIDER
 ON D3 THRU EARLY D4 MOTORS YOU MUST REPLACE
 THE R-4100 SEPARATOR, R-4101 SPIDER AND THE
 R-H555 NUT.