

TROUBLESHOOTING		
No. of Red Light Blinks	Fault Description	Steps to Fix To be Performed by Professional HVAC Technician Only
3	Failure to fill tank with water.	<ul style="list-style-type: none"> <li>Ensure inlet water is on.</li> <li>Check for leaks around the tank seal and solenoid valve.</li> <li>Turn off water supply and replace in-line water filter.</li> <li>Press/hold RESET button until the red Call Service light turns off.</li> <li>If tank still fails to fill, press and hold the EMPTY button for 3 seconds (if unit fails to drain, unplug unit and make sure water in tank is cool).</li> <li>Follow tank cleaning instructions in the Professional Installation Guide. Ensure you have a firm grip of the tank prior to releasing the tank, especially if water is present.</li> <li>Clear any excess debris from the tank's bottom orifice to the solenoid valve.</li> <li>Reassemble tank and plug unit back in. Press the RESET button.</li> <li>If water still fails to flush into the tank, replace the solenoid valve.</li> </ul>
4	Heating element overheated.	<ul style="list-style-type: none"> <li>Press and hold the EMPTY button for 3 seconds.</li> <li>Follow tank cleaning steps in the Professional Installation Guide.</li> <li>Reassemble tank and press the RESET button.</li> <li>If fault returns, replace with applicable unit.</li> </ul>
5	Input voltage insufficient.	<ul style="list-style-type: none"> <li>Problem most likely due to voltage variation from service provider, or faulty wiring in the home. If problem is due to TrueSTEAM service alone, the fault should correct itself when voltage levels return to normal.</li> <li>Press and hold the RESET button until CALL SERVICE light shuts off.</li> <li>Initiate a humidistat call for humidity and monitor for fault light to return.</li> <li>If fault returns, check the line cord input voltage before and during humidistat call. Line voltage should not drop below 102Vrms to ensure TrueSTEAM operates properly.</li> </ul>

TROUBLESHOOTING		
No. of Red Light Blinks	Fault Description	Steps to Fix To be Performed by Professional HVAC Technician Only
6	Water overflow sensed.	<ul style="list-style-type: none"> <li>Ensure drain hose is not kinked or submerged in water at the drain. Check functionality of condensate pump if used.</li> <li>Check for water coming out of drain/overflow line. If continuous water flow is present, follow the cleaning steps in the Professional Installation Guide (69-2036).</li> <li>After cleaning, set humidistat on and monitor operation.</li> <li>If fault returns, unplug TrueSTEAM.</li> <li>Loosen cover screw and remove cover.</li> <li>Disconnect water level sensor wiring and lift snap-hinge clamp to remove water sensor assembly. See image on page 5.</li> <li>Clean probes using warm soapy water so that the metal is exposed. It is OK to use steel wool or brush.</li> <li>Reassemble the sensor assembly in the unit, reattach and secure cover.</li> <li>Plug unit in, and press RESET button.</li> <li>If fault reappears, replace water sensor assembly and/or solenoid valve.</li> </ul>
7	HVAC power not present.	<ul style="list-style-type: none"> <li>Turn humidistat off.</li> <li>At thermostat, validate that the FAN setting turns the blower on. If not, check the circuit breaker. If circuit is tripped, reset or replace fuse.</li> <li>If fault persists, unplug TrueSTEAM and remove cover.</li> <li>Validate proper TrueSTEAM wiring to R and C terminals, using installation guide (69-2036).</li> <li>Ensure proper connection quality of the wires.</li> <li>Inspect R and C wires at the HVAC equipment board, ensuring no breaks and good connection if wire nuts are used.</li> <li>Hook AC volt meter across R and C to validate 20-30VAC is present. To measure, it may be necessary to close furnace interlock switch.</li> <li>Secure TrueSTEAM cover and plug unit in. Press the RESET button.</li> <li>If fault persists, recheck wiring or replace unit.</li> </ul> <p><b>Note:</b> If using VisionPRO IAQ to control TrueSTEAM, it is not necessary to monitor HVAC power. DIP 4 may be turned on to disable monitor.</p>

TROUBLESHOOTING		
No. of Red Light Blinks	Fault Description	Steps to Fix To be Performed by Professional HVAC Technician Only
8-11	The backup weld monitor input is active when the backup heater relay is off.	<ul style="list-style-type: none"> <li>Replace the TrueSTEAM unit.</li> </ul>
12	Temperature of the electronic circuit board is too high.	<ul style="list-style-type: none"> <li>Ensure ventilation holes in the cover are clear of obstruction, and that 1 foot of clearance is maintained around the cover's ventilation holes.</li> <li>Ensure the TrueSTEAM is installed in a location with conditioned air 32°F (0°C) to 104°F (40°C).</li> <li>Turn humidistat off and allow time for electronic board to cool. Unplugging unit and removing cover will facilitate this.</li> <li>Turn humidistat on and press RESET button.</li> <li>Confirm humidity call starts (HUMIDIFYING light turns on).</li> <li>Allow unit to run and check for steam leaks around tank and ventilation holes.</li> <li>If steam is present, replace TrueSTEAM.</li> </ul>
13	Tank failed to drain.	<ul style="list-style-type: none"> <li>Water in tank may be hot (&gt;140°F [60°C]) and can cause burns.</li> <li>Press and hold the EMPTY button for 3 seconds.</li> <li>If unit fails to drain, turn humidistat to OFF, or unplug the humidifier and wait for water in tank to cool. Ensure tank water is cool before proceeding.</li> <li>Once cool, follow tank cleaning steps in the Professional Installation Guide (69-2036EFS).</li> <li>Reassemble tank and press the RESET button.</li> <li>If fault persists, replace the solenoid valve.</li> </ul>
14	Heater failed to boil water.	<ul style="list-style-type: none"> <li>Press and hold EMPTY button for 3 seconds, and follow tank cleaning steps in the Professional Installation Guide.</li> <li>Reassemble tank and press the RESET button.</li> <li>Initiate humidistat call.</li> <li>If fault returns, replace the unit.</li> </ul>

TROUBLESHOOTING		
No. of Red Light Blinks	Fault Description	Steps to Fix To be Performed by Professional HVAC Technician Only
15	No Airflow.	<ul style="list-style-type: none"> <li>Unplug TrueSTEAM and remove cover</li> <li>Validate proper wiring to terminals R and C, using the diagrams in the installation guide (69-2036).</li> <li>Ensure proper connection quality of the wires.</li> <li>Inspect R and C wires at the HVAC equipment board, ensuring no breaks and good connection if wire nuts are used.</li> <li>Hook AC volt meter across airflow switch normally-open (N.O.) terminal and R.</li> <li>Set thermostat FAN to off and reduce system setpoint.</li> <li>Validate 0 VAC reading on AC Volt Meter</li> <li>Set thermostat FAN to on.</li> <li>Once blower starts, validate 20-30VAC reading on AC volt meter.</li> <li>If voltage is not present, check wiring and switch functionality. Differential pressure switch may require a new install location (away from duct bends, etc), or it may need to be replaced.</li> <li>If voltage is present, continue to troubleshoot to validate proper airflow monitoring.</li> <li>Keep AC volt meter across airflow switch N.O. terminal and R from HVAC unit.</li> <li>Turn humidistat off.</li> <li>Ensure DIP 4 and 5 are in off (down) position.</li> <li>Secure TrueSTEAM cover and plug in unit. Press the RESET button.</li> <li>Set thermostat FAN to off and reduce system set point.</li> <li>Set humidistat call and monitor device. (may take 15-20 minutes)</li> <li>When sound of blower clears, validate within 2 minutes that the AC volt meter reads 20-30VAC.</li> <li>If time for switch to change state takes longer than 2 minutes, try a new install location for the switch, where state change is faster.</li> </ul>

# Honeywell

## TrueSTEAM

### HM512, HM509, and HM506

### TROUBLESHOOTING AND PARTS REPLACEMENT GUIDE



## SOLENOID VALVE REPLACEMENT



**CAUTION:** Ensure outside of tank is cool before removing to prevent possible injury.

1. Ensure the TrueSTEAM is empty, and unplug.
2. Shut off and disconnect the water line from the bottom of the unit.
3. Unlock the red lever and disengage the tank from the valve assembly and remove tank.
4. Remove TrueSTEAM from the mounting bracket.
5. Remove the cover with a flathead or Torx screwdriver.
6. Disconnect the valve wire plug from the circuit board.
7. Using a flathead screwdriver, disengage the frame's backplate at the four locations.
8. Slide the valve out of the back of the frame, and ease the wiring out of the TrueSTEAM frame.
9. Reassemble with the new solenoid valve, following steps 2–8 in reverse order.

## IN-LINE WATER FILTER

1. Turn off water supply at the source (i.e. saddle valve)
2. Push in on the filter's compression snap-lock fittings where the 1/4-in. water line connects.
3. Pull out the water line as you are pushing in the snap-locks.
4. Install the new water filter, ensuring directional water flow is accurate per the filter label, by inserting the water lines on either end of the filter.
5. Initiate a call for humidity by turning the humidistat on.
6. Check the filter after 5 minutes of humidifier operation to ensure no water leakage.

## WATER TANK

1. Press and hold the EMPTY button for 3 seconds.
2. Water will drain from the tank and the CLEAN TANK light will blink as it drains.
3. When the CLEAN TANK is on solid, the tank is empty.
4. Turn the water valve arm to the UNLOCK position. Grip the solenoid toggle valve and slide it back to disengage.
5. Hold bottom of the tank while pressing down the safety release button on the cover and slide the handle forward.
6. The sediment screen is on the inside of the tank at the bottom. Push the release button away from the tank wall to disengage the screen.
7. Pull out and clean or replace the screen.
8. Clean tank and reattach.

## WATER SENSOR ASSEMBLY

1. Unplug the TrueSTEAM.
2. Remove the cover with a flathead or Torx screwdriver.
3. Disconnect the water sensor wire from the electric circuit board.
4. Remove the Torx screw holding down the water sensor assembly.
5. Lift the metal hinge and remove the sensor assembly.
6. Replace with the new sensor assembly and connect the new wires to the assembly and the circuit board.
7. Reattach the cover.
8. Plug in the TrueSTEAM.

**A B**

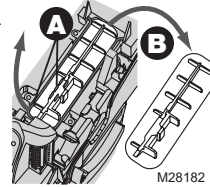

## REPLACEMENT PARTS

Part	Part Number	Fig. Ref
10-foot Remote Hose and Nozzle Kit	50024917-001	1
20-foot Remote Hose and Nozzle Kit	50024917-002	1
Cover	50028004-001	2
Duct Nozzle	50028003-001	3
Remote Nozzles	50028001-001	4
Mounting Bracket	50020012-001	5
Solenoid Valve	50027997-001	6
In-Line Water Filter	50028044-001	7
HM512/HM509 Water Tank	50033181-001	8
HM506 Water Tank	50033182-001	9
Water Level Sensor Assembly	50027998-001	10
Saddle Valve	32001616-001	11
Back-flow Water Valve	50030142-001	12
Differential Pressure Switch	50027910-001	13

## REPLACEMENT PARTS

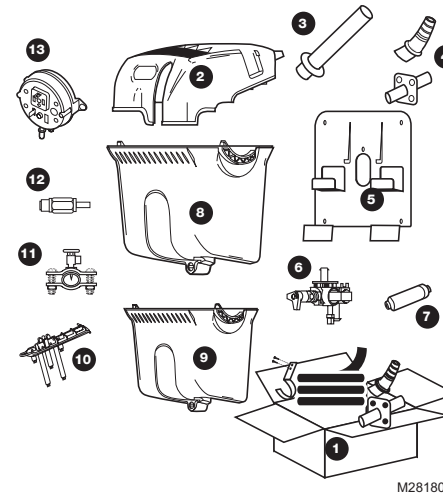

## TROUBLESHOOTING

TrueSTEAM has internal diagnostics that monitor system operation, maintenance schedules, and faults. If a system fault is detected, the system will attempt to recover itself up to five times in a 24 hour period. If unable to recover in that time, the red Call Service LED light will activate.

If the TrueSTEAM Call Service light is red, a system fault has occurred from which the humidifier can not recover by itself. The table below shows the possible faults, along with steps to fix TrueSTEAM.

If the red Call Service LED light is on, press/release the RESET button. The red Call Service LED light will begin blinking in a series that indicates what fault occurred. Refer to the table below for the fault signified by the number of blinks that occur.

Press/hold the RESET button to clear the Service Timer light.

Press and hold the EMPTY button for 3 seconds to drain the tank.

## TROUBLESHOOTING

No. of Red Light Blinks	Fault Description	Steps to Fix To be Performed by Professional HVAC Technician Only
1	Water/Heater temperature sensor failed.	<ul style="list-style-type: none"> <li>• Unplug TrueSTEAM and remove cover.</li> <li>• Check water sensor connection to electronic board.</li> <li>• Reattach cover and plug TrueSTEAM in.</li> <li>• If fault reappears, press and hold the EMPTY button for 3 seconds and follow tank cleaning steps in the Professional Installation Guide (69-2036).</li> <li>• Reassemble tank and press the RESET button.</li> <li>• If fault returns, replace the unit.</li> </ul>
2	Water sensors failed.	<ul style="list-style-type: none"> <li>• Unplug TrueSTEAM and remove cover.</li> <li>• <b>A</b> Disconnect water level sensor wiring, remove screw and lift clamp.</li> <li>• <b>B</b> Remove water sensor assembly.</li> <li>• Clean sensor probes using warm soapy water so that the metal is exposed. It is OK to use steel wool or brush.</li> <li>• Reassemble the sensor assembly in the unit, reattach and secure cover.</li> <li>• Plug unit back in and press the RESET button.</li> <li>• If fault reappears, replace sensor assembly.</li> </ul>

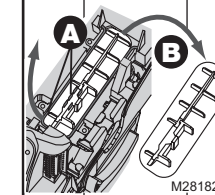

*Continued on other side...*



Printed in U.S.A. on recycled paper containing at least 10% post-consumer paper fibers.

## Automation and Control Solutions

Honeywell International Inc.  
1985 Douglas Drive North  
Golden Valley, MN 55422

Honeywell Limited-Honeywell Limitée

35 Dynamic Drive  
Toronto, Ontario M1V 4Z9  
<http://yourhome.honeywell.com>

© U.S. Registered Trademark  
© 2008 Honeywell International Inc.  
All Rights Reserved  
69-2144-03 M.S. 06-08

**Honeywell**