

This Owner's Manual is provided and hosted by [Appliance Factory Parts](#).



Coleman 9998 Owner's Manual

[Shop genuine replacement parts for Coleman 9998](#)



[Find Your Coleman Grill Parts - Select From 255 Models](#)

----- Manual continues below -----



Gas Barbecue Use, Care & Assembly Manual With Grill Lighting Instructions

Model 9998 Series (LP Gas)

ASSEMBLER/INSTALLER:
Leave these instructions with the consumer.

CONSUMER/USER:
Read all instructions and keep in a safe place for future reference.



www.coleman.com

NOTE:
Propane tank is not included.

IMPORTANT

Read this manual carefully before assembling, using or servicing this grill. Keep this manual for future reference. If you have questions about assembly, operation, servicing or repair of this grill, please call Coleman at 1-800-356-3612 or TDD: 316-832-8707. In Canada call 1 800 387-6161.

For Outdoor Use Only





ANSI Z21.58-2007 • CSA 1.6-2007
Outdoor Cooking Gas Appliances

Contents

General Safety Information	2
General Installation	3
Electrical Attachments	3
Portable L.P. Gas Barbecue Cylinders	4
L.P. Gas Cylinder	4
Hose and Regulator	5
Transporting the Refillable Cylinder	5
Grill Features	6
Parts Identification	7
Grill Assembly	8
20# LP Cylinder Installation	11
Leak Testing - Refillable Cylinders	12
Fixing a Fuel Leak	13
Start-Up Check List	13
Lighting Instructions	14
Shutting Off the Grill	15
General Use and Correct Burner Flames	15
Grilling Tips and Hints	16
In Case of Grease Fire	16
Cooking Methods	16
Care, Maintenance, and Cleaning	16
Moving and Storage	19
Troubleshooting	19
For Your Additional Safety	20
Registration Card	21
Replacement Parts List	23
Warranty	24

General Safety Information

This manual contains important information about the assembly, operation and maintenance of this product and system. General safety information is presented in these first few pages and is also located throughout the manual. Particular attention should be paid to information accompanied by the safety alert symbols: “ DANGER”, “ WARNING”, “ CAUTION”.

Keep this manual for future reference and to educate new users of this product. This manual should be read in conjunction with the labeling on the product.

Safety precautions are essential when any mechanical or propane fueled equipment is involved. These precautions are necessary when using, storing, and servicing. Using this equipment with the respect and caution demanded will reduce the possibilities of personal injury or property damage.

The following symbols shown below are used extensively throughout this manual. Always heed these precautions, as they are essential when using any mechanical or fueled equipment.

DANGER

DANGER indicates an imminently hazardous situation which, if not avoided, will result in death or serious injury.

WARNING

WARNING indicates a potentially hazardous situation which, if not avoided, could result in death or serious injury.

CAUTION

CAUTION indicates a potentially hazardous situation which, if not avoided, may result in minor or moderate personal injury, or property damage.

DANGER

If you smell gas:

- 1. Shut off gas to the appliance.**
- 2. Extinguish any open flame.**
- 3. Open lid.**
- 4. If odor continues, keep away from the appliance and immediately call your gas supplier or your fire department.**

WARNING

- 1. Do not store or use gasoline or other flammable liquids or vapors in the vicinity of this or any other appliance.**
- 2. An LP cylinder not connected for use shall not be stored in the vicinity of this or any other appliance.**

WARNING

Combustion by-products produced when using this product contain chemicals known to the State of California to cause cancer, birth defects, or other reproductive harm.

DANGER

- **FOR OUTDOOR USE ONLY.** NEVER operate grill in enclosed areas, as this could lead to gas accumulating from a leak, causing an explosion or a carbon monoxide buildup which could result in injury or death. DO NOT use in garages, breezeways, sheds or any enclosed area.
- **NOT FOR USE BY CHILDREN.**
- If these instructions are ignored, a hazardous fire or explosion could result in physical injury, death or property damage!

WARNING

- DO NOT move grill while it is lit.
- Keep outdoor cooking gas appliance area clear and free from combustible materials, gasoline and other flammable vapors and liquids.

WARNING

- NEVER place more than 10 pounds on a side table. DO NOT lean on grill.
- NEVER use charcoal briquettes or lighter fluid in a gas grill.
- Grill is hot when in use; to avoid burns, DO NOT touch any hot grill surface. Keep children and pets away from hot grill.
- NEVER leave the grill unattended while it is in use.
- It is your responsibility to assemble, install, operate and care for your gas grill properly.
- DO NOT vent propane vapor from the cylinder before taking it to be refilled.
- DO NOT use gas grill indoors or store any propane cylinder(s) indoors, including in the garage, breezeways, sheds or enclosed areas.
- Under some circumstances, propane may lose the distinctive odor that was added. Keep the service valve closed and plugged or capped (as recommended by the manufacturer) when the cylinder is not connected to the appliance, including "empty" cylinders. Other strong odors may hide or mask the odor of propane. Colds, allergies, sinus congestion, and the use of tobacco, alcohol or drugs may impair your ability to detect the odor of propane.

General Installation

- Installation must conform with local codes or, in the absence of local codes, with either the [National Fuel Gas Code](#), ANSI Z223.1/NFPA 54, [Natural Gas and Propane Installation Code](#), CSA B149.1, or [Propane Storage and Handling Code](#), CSA B149.2, as applicable.
- To check local codes, see your local L.P. gas dealer listed in the Yellow Pages for recommended installation procedures and regulations.

WARNING

This appliance is not to be installed in or on a recreational vehicle and/or boat.

Follow these safety rules before each use:

1. A minimum clearance of 36 inches from the left, right and back sides of the grill must be maintained between the grill and any combustible construction such as wood siding of a building.
2. Never locate the grill under an unprotected combustible material or overhang.
3. Do not obstruct the flow of combustion and ventilation air. Maintain a minimum clearance of 3 inches from the back of the grill and non-combustible construction such as a concrete or brick wall.
4. Keep the ventilation opening(s) of the cylinder enclosure free and clear from debris.
5. The grill should be level and not facing directly into the wind.

WARNING

Keep any electrical supply cord and the fuel supply hose away from any heated surfaces. During assembly of grill and when attaching or replacing the L.P. gas cylinder, insure that the gas supply hose is free of kinks and is at least 3 inches away from hot surfaces such as the grill housing.

WARNING

A liquid propane tank, not connected for use with this gas barbecue, shall not be stored in the vicinity of this or any other appliance.

Connections must comply with local requirements and are the sole responsibility of the person performing the work.

A certified plumber must make connection to gas source.

Electrical Attachments

The maximum sum total amperage rating of electrical accessories attached to the 9998 Series Coleman Grill must not exceed **10 amps**.

When using an electric attachment with the grill, follow the specification and warning statements accompanying the attachment.

IMPORTANT: If using an external electrical source, the installed appliance must be electrically grounded according to local codes or, in the absence of local codes, with the [National Electrical Code](#), ANSI/NFPA 70 or the [Canadian Electrical Code](#) CSA C22.1.

1. To protect against electric shock, do not immerse cord or plugs in water or other liquid.
2. Unplug from the outlet when not in use and before cleaning. Allow to cool before putting on or taking off parts.
3. Do not operate any outdoor cooking gas appliance with a damaged cord, plug, or after the appliance malfunctions or has been damaged in any manner. Contact Coleman for repair.
4. Do not let the cord hang over the edge of a table or touch hot surfaces.
5. Do not use an outdoor cooking gas appliance for purposes other than intended.
6. When connecting, first connect accessories to the electrical receptacle in the rear of the grill, next connect the short service cord on the grill to the extension cord, and finally connect the extension cord to the power supply.
7. Use only a Ground Fault Interrupter (GFI) protected circuit with this outdoor cooking gas appliance.
8. Never remove the grounding plug or use with an adapter of 2 prongs.
9. Use only extension cords with a 3 prong grounding plug, rated for the power of the equipment, and approved for outdoor use with a W-A marking.

WARNING

Electrical Grounding Instructions

This outdoor cooking gas appliance is equipped with a three-prong (grounding) plug for your protection against shock hazard and must be plugged directly into a Ground Fault Circuit Interrupter (GFCI) system. Do not cut or remove the grounding prong from this plug.

Longer detachable power-supply cords or extension cords must be used with care. The marked electrical rating of the cord set or extension cord must be at least as great as the electrical rating of the appliance. Keep the connection to an extension cord away from water and off the ground. Arrange the cord so that it will not drape over the countertop or tabletop where it can be pulled on by children or tripped over unintentionally.

Never clean any electrical product with water or cleaning fluids. Store electrical products indoors and out of reach of children when not in use. DO NOT allow cord to touch any hot surfaces which could melt insulation.

Portable L.P. Gas Barbecue Cylinders

Liquefied Petroleum gas (abbreviated L.P. gas or propane), is highly flammable. It becomes liquid when stored under high pressure inside a cylinder and vaporizes when released. L.P. gas is heavier than air and tends to collect in low areas. It is important that there are no leaking connections on your gas grill that could cause a fire or explosion (see the section titled "LEAK TESTING").

Portable LP gas grills require a fuel delivery system which is comprised of a valve [A], a hose [B], a regulator [C] with vent hole [G], an L.P. gas supply cylinder [D], a Type 1 coupling nut [E] and a Type 1 cylinder valve [F], (Fig. 1).

⚠ WARNING

Your new barbecue grill is equipped with a Type 1 coupling nut [E]. DO NOT attempt to connect to any other refillable L.P. cylinder not equipped with a mating Type 1 cylinder valve [F]. This grill may only be used with cylinder connecting devices approved by Coleman.

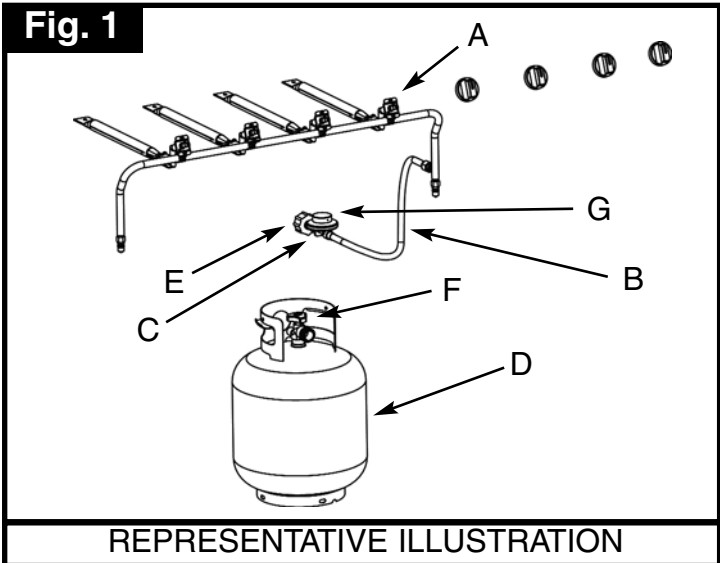

L.P. Gas Cylinder

⚠ DANGER

- DO NOT insert any foreign objects into the valve outlet. You may damage the valve. A damaged valve can cause a leak, which could result in explosion, fire, severe personal injury or death.

⚠ WARNING

- Refillable cylinders must be stored outdoors out of the reach of children and must not be stored in a building, garage or any other enclosed area (Fig. 2).

Cylinder Specifications

- Any refillable L.P. gas supply cylinder used with this grill must be approximately 12 inches diameter and 18 inches high. The maximum fuel capacity is 80% and is approximately 20 pounds of propane.
- The maximum weight of a properly filled cylinder will be approximately 38 pounds (47.7 lbs. nominal water capacity).
- The L.P. cylinder must have a shut-off valve terminating in a Type 1 L.P. gas cylinder valve outlet (see item [F], Fig. 1).



- A Type 1 compatible cylinder with a Type 1 cylinder valve has a back-check valve which does not permit gas flow, until a positive seal has been obtained.
- The cylinder must be arranged in an upright position for vapor withdrawal. It must also include a collar to protect the cylinder valve. A safety relief device having direct communication with the vapor space of cylinder must be provided. This will expel high pressure gas if the cylinder is over filled or overheated which could result in fire or explosion.
- All refillable L.P. gas cylinders used with this appliance shall be constructed and marked in accordance with the Specifications for L.P. Gas Cylinders of the U. S. Department of Transportation (DOT) or the National Standard of Canada, CAN/CSA-B339, Cylinders, Spheres and Tubes for Transportation of Dangerous Goods; and Commission, as applicable; and shall be provided with a listed overfilling prevention device, and a cylinder connection device compatible with the connection for outdoor cooking appliances.
- Read labels on the L.P. Gas Supply Cylinder.
- New refillable cylinders are always shipped empty for safety.
- Allow only qualified L.P. gas dealers to fill or repair your refillable L.P. gas supply cylinder.
- Inform the gas dealer if it is a new or used cylinder to be filled.
- Caution the gas dealer not to overfill the cylinder.
- After filling, have the gas dealer check for leaks and to see that the relief valve remains free to function.

⚠ CAUTION

Have the gas dealer weigh the cylinder after filling to ensure that the cylinder is not over filled.

Hose and Regulator

The Type 1 connection system has the following features:

1. The system will not allow gas to flow until a positive connection has been made.

NOTE: The cylinder control valve must be turned off before any connection is made or removed.

2. The system has a thermal element that will shut off the flow of gas in the event of a fire.
3. The system has a flow limiting device which, when activated, will limit the flow of gas to 10 cubic feet per hour.
4. NEVER use grill without leak testing this connection.

⚠ WARNING

- DO NOT attempt to adjust the regulator as this could create a situation causing personal injury or property damage.

The pressure regulator and hose assembly with the Type 1 fitting supplied with the appliance must be used. Do not use another hose and regulator assembly other than the one supplied with the grill or a Coleman® replacement pressure regulator assembly. The pressure regulator and hose assembly provided is factory set at an outlet pressure of 11 inches water column (1/2 psi).

- Keep the small vent hole in the regulator clean of dirt and debris (see item [G], Fig. 1).
- Consult your L.P. gas dealer if you think the regulator is not working properly.

⚠ WARNING

During assembly of the grill and when attaching or replacing the L.P. gas cylinder, insure that the gas supply hose is free of kinks and/or damage and is at least 3 inches away from hot surfaces such as the grill housing.

Transporting the Refillable Cylinder

- Transport only one refillable cylinder at a time.
- Transport the cylinder in an upright and secure manner with a control valve turned off and the cap in place.
- DO NOT transport the cylinder in the passenger compartment, unless you have an open window ventilation.
- DO NOT leave the cylinder in direct sunlight or in a high heat area such as a closed car trunk. High heat areas could cause the relief valve to vent gas.
- Use a cylinder cap on the cylinder valve outlet during transport and when the cylinder is not connected to the grill.
- Keep the cylinder valve closed when not in use.
- Take the cylinder directly home after it has been filled.

Transporting the Refillable Cylinder (continued)

⚠ WARNING

Handle a full cylinder with care. Gas is under high pressure.

⚠ DANGER

- NEVER store a spare L.P. gas supply cylinder under the grill body or inside the grill enclosure or in the vicinity of any heat producing appliance. (Fig. 3)
- NEVER fill the cylinder beyond 80% full.

Failure to follow this information exactly could result in an explosion and/or fire causing death or serious injury.

Fig. 3

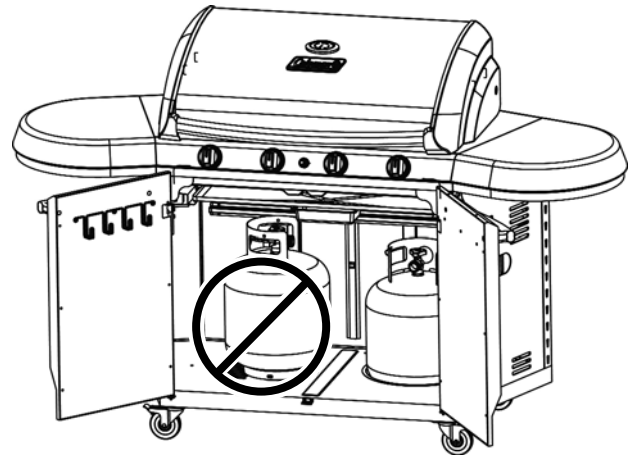

REPRESENTATIVE ILLUSTRATION

Grill Features – 9998 Series

Fig. 4

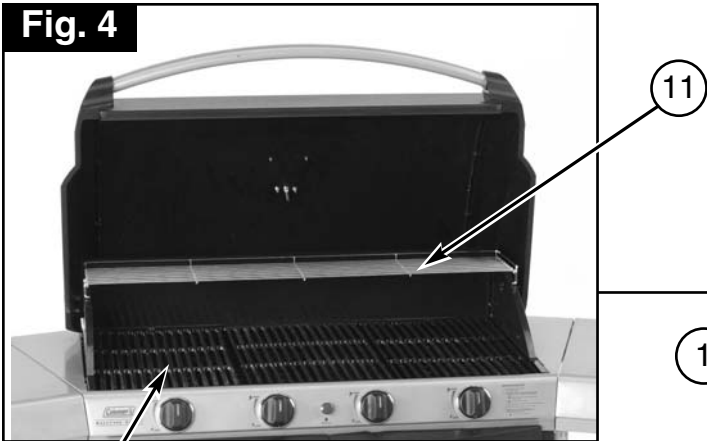

Fig. 5

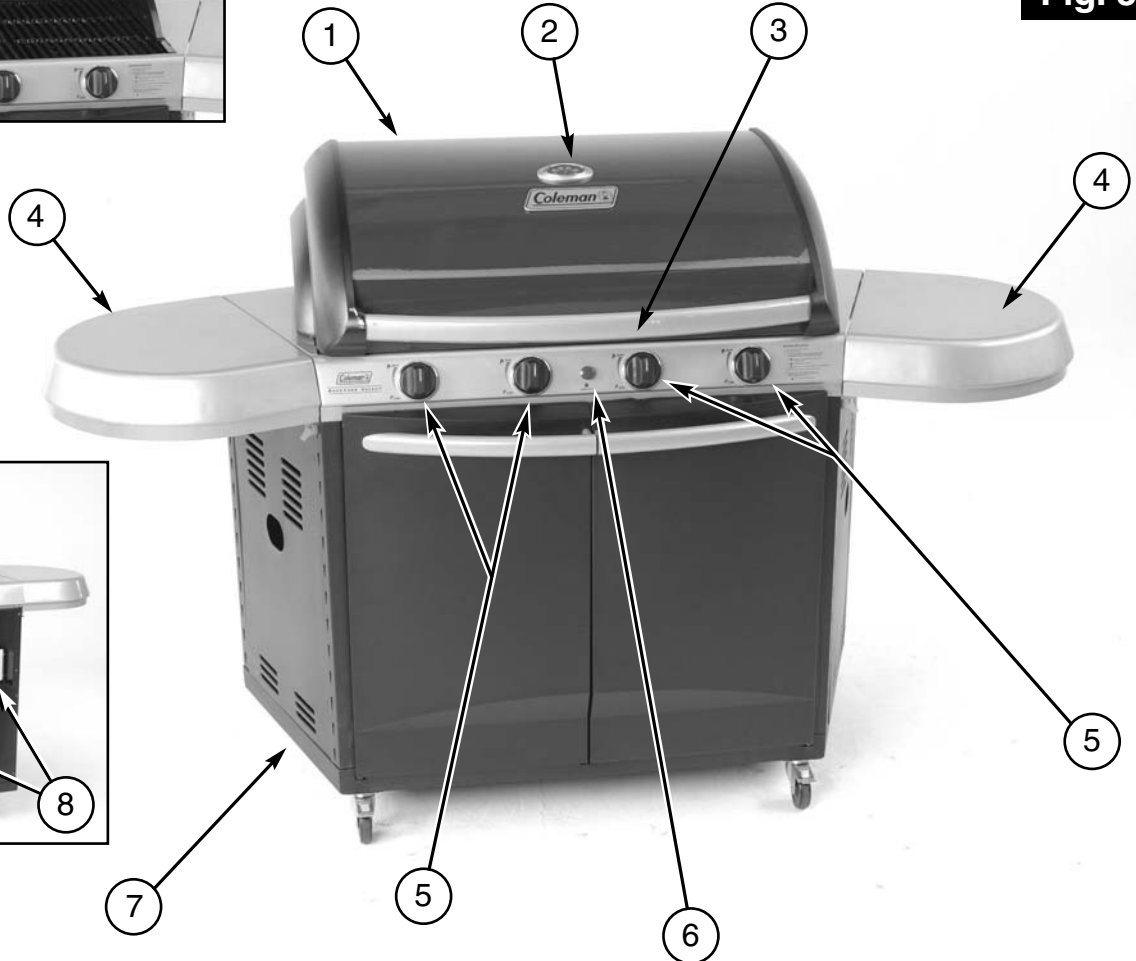
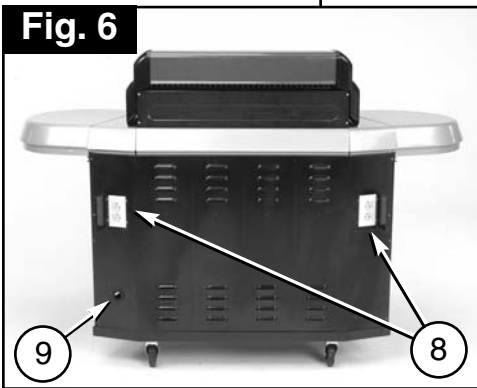

Fig. 6



- | | |
|-----------------------|----------------------------------|
| 1. Grill Hood | 7. Cart with Doors |
| 2. Thermometer | 8. 120 VAC Electrical Outlet |
| 3. Hood Handle | 9. 120 VAC Electrical Cord Inlet |
| 4. Side Shelf | 10. Grilling/Cooking Surface |
| 5. Control Knobs | 11. Warming Shelf |
| 6. Electronic Igniter | |

NOTE: See your dealer for Side Solution™ accessories that are purchased separately.

IMPORTANT: Remove all packing material prior to assembly/use. If your grill has stainless steel components, remove all protective plastic film from stainless steel parts prior to assembly/use. This film is installed at the factory to prevent damage that could occur during shipment and handling.

Fig. 7

NOTE: On some models, some of the parts illustrated are pre-assembled at the factory.



Grill Assembly

Assemble the Wheels

1. Place part of the shipping carton behind the grill for protection. Lay the grill on its back to assemble the four wheels (Fig. 8).
2. Assemble the locking wheels at the front of the grill. Secure each wheel with four metal washers and four screws. The washers assemble next to the heads of the screws.
3. Carefully lift the grill cart upright onto the wheels.

Fig. 8

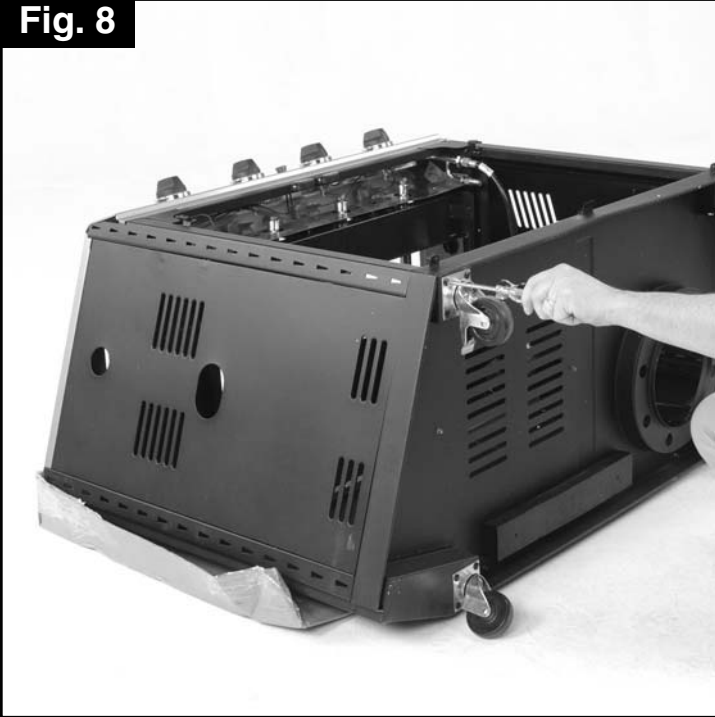

Assemble the Wind Screen

1. Remove three screws and lockwashers at location "A". These are the mounting screws for the rear windscreen (Fig. 9).

Fig. 9

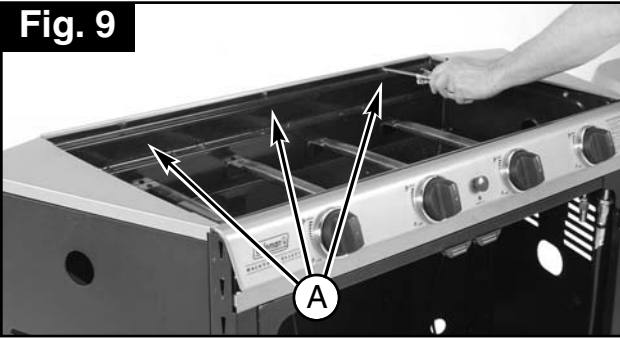

2. Attach the rear windscreen with three screws. The lockwashers assemble next to the heads of the screws (Fig. 10).

Fig. 10



3. Assemble the side windbaffles. Each side windbaffle is held in place with four screws and lockwashers. The lockwashers assemble next to the heads of the screws (Fig. 11, 12, and 13).

Fig. 11

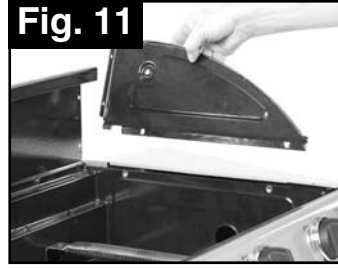
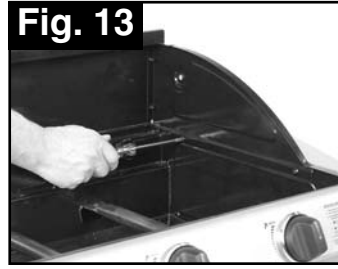

Fig. 12



Fig. 13



Assemble the Grease Diverter

NOTE: On some models, the Grease Diverter is pre-assembled at the factory.

1. The Grease Diverter is installed without tools. It is to be located right below the burners with tabs inserted into slots (Fig. 17).
2. Install the Grease Diverter from above by slipping it down between the burners and through the opening in the grill firebox (Fig. 14).
3. Once it is below all the burners, position it horizontally (Fig. 15) and align the tabs with the slots. A slight amount of spring tension in the diverter will hold it in place when the tabs are positioned in the slots (Fig. 16).

Fig. 14



Fig. 15

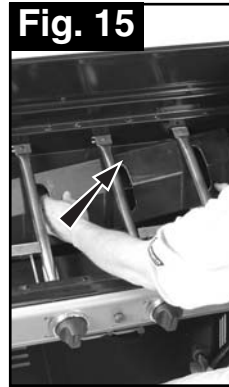

Fig. 16



Assemble the Heat Tents and the Cooking Grates

Fig. 17



Fig. 18



Grill Assembly

Assemble the Grill Lid

1. Hardware to attach the grill lid are two pins and hairpin cotters (Fig. 19).
2. Carefully place the Grill Lid onto the grill frame in the closed position (Fig. 20).



3. Insert each pin through the lid and windscreen (Fig. 21). Raise the lid slightly to help align the holes.



5. Install one hairpin cotter on each pin (Fig. 23).



Assemble the Thermometer

1. Hardware to attach the thermometer are two wing nuts. Finger tighten the wing nuts on the inside of the lid. DO NOT OVERTIGHTEN the wing nuts (Fig. 24 and 25).



Assemble the Warming Rack and the Grease Tray



4. Carefully raise the lid to the open position (Fig. 22).



Assemble the Propane Tank Retainer

1. Insert the ends of the Propane Tank Retainer into the holes provided in the right side panel (Fig. 29). Use the pins provided with the Retainer to secure the Retainer in place.

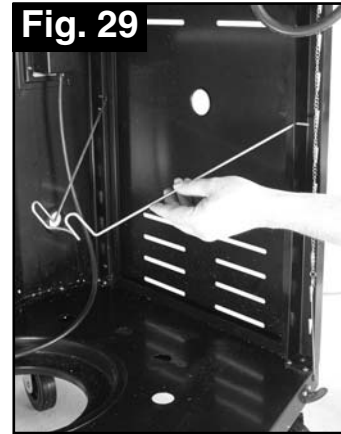

Assemble the Wire Shelf

1. Insert the ends of the Wire Shelf into the holes provided in the back panel. Use a screwdriver to attach the shelf to the base with two screws (Fig. 30).

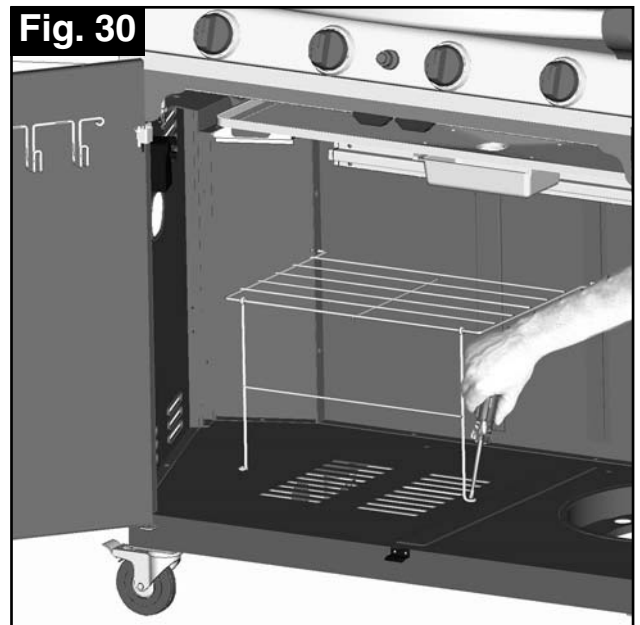

Assemble the Doors and the Tool Hook

NOTE: On some models, the Doors and the Tool Hook are pre-assembled at the factory.

1. Install both doors by first inserting the lower pin and the upper pin in the hinge holes at the same time (Fig. 31).
2. Assemble the Tool Hook to the left door using three screws. Tighten the screws with a screwdriver (Fig. 32).

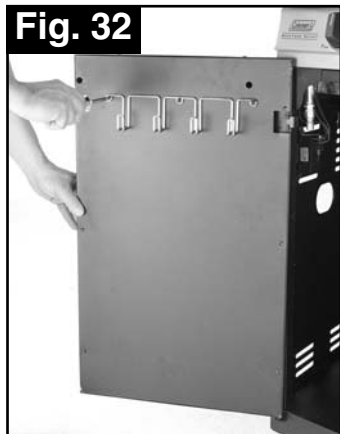
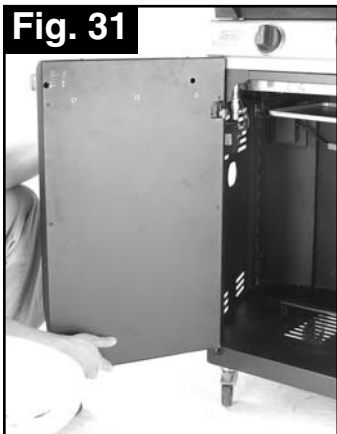

Assemble the Doors Handles

1. Assemble two sets of handles with parts illustrated in (Fig. 33).

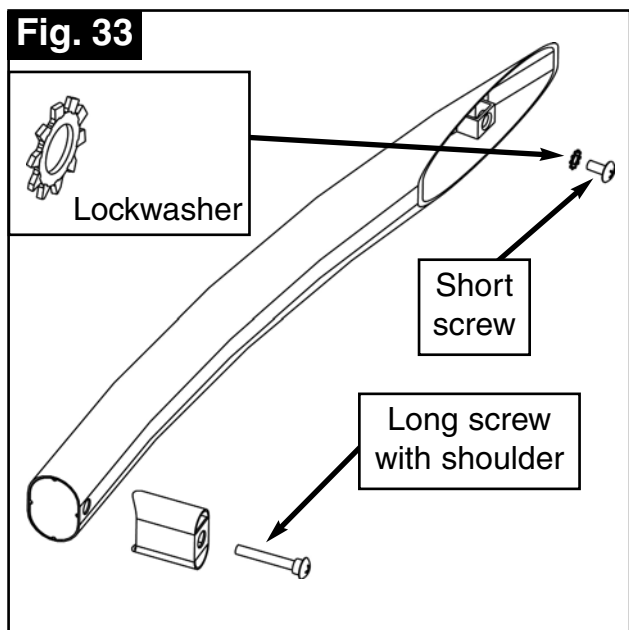

2. Loosely engage the screws only several turns (Fig. 34). In the next step, the screw heads will engage slots in the doors before they are tightened.

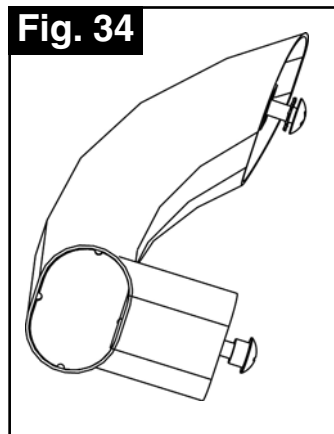

3. Insert the screw heads into the slots in the outside of the door. The screws must be inserted in sequence. First, slide the short screw into the slot. The lockwasher must touch the screw head. Next, insert the long screw (Fig. 35). **PLEASE NOTE:** Only the slender portion of the long screw will slide past the narrow part of the slot. This feature locks the shoulder screw in place.

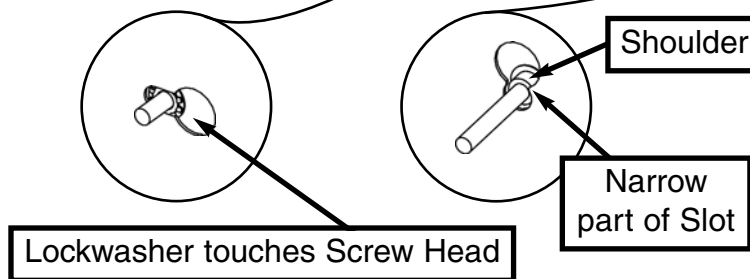
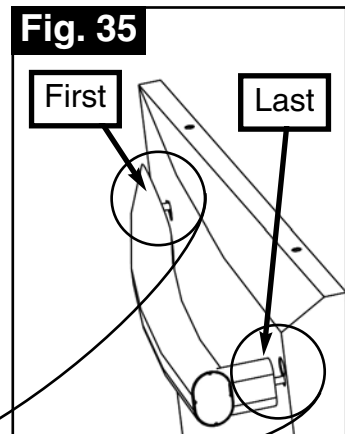

4. Tighten both screws with a screwdriver. Access holes are provided on the inside of each door (Fig. 36).

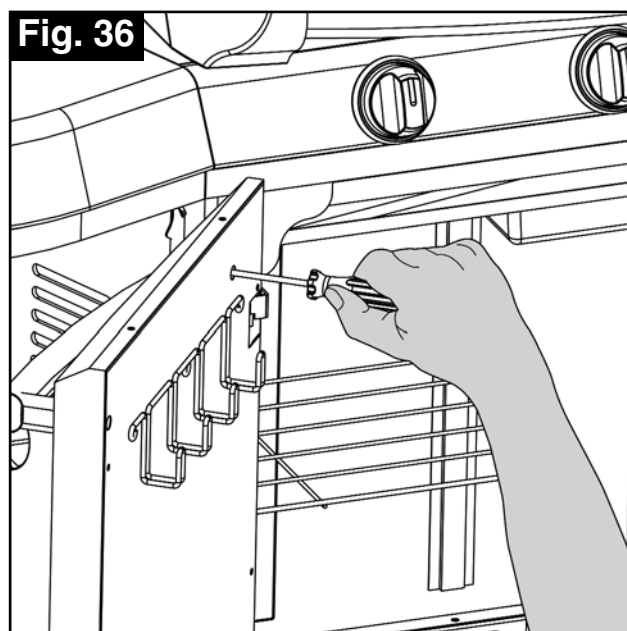

Grill Assembly (continued)

Assemble the Side Tables

1. Align the tabs on the Side Tables with the slots on the side of the grill (Fig. 37).
2. Use firm pressure to push the Side Tables down and into place (Fig. 38). The joint between the Side Tables and the Grill will be even.



3. Engage the locks by firmly pushing the tabs into the slots (Fig. 39). Be sure to engage two locks on each side table.



20# LP Cylinder Installation

NOTE: Your 9998 Series grill is set up from the factory to use a 20# refillable LP cylinder. You may purchase a 20# LP cylinder from the store where you bought your grill, or from your local propane dealer.

! WARNING

This procedure **MUST** be performed **OUTDOORS** only! Be sure the L.P. cylinder valve is closed. Attach to the grill. Read and follow the directions on the cylinder.

20# LP Cylinder Installation (continued)

1. Set the LP Cylinder in the Cylinder Support location with the outlet valve facing toward the door opening of the grill. Lower the Tank Support to engage the Cylinder Collar (Fig. 40).



! WARNING: During assembly of the grill and when attaching or replacing the L.P. gas cylinder, insure that the gas supply hose is free of kinks and/or damage and is at least 3 inches away from hot surfaces such as the grill casting.

! CAUTION

In the connection process, the grill side of the connection will seal on the back-check in the valve, resulting in a slight resistance. The connection requires about one-half to three-quarters additional turn to complete the connection. To disconnect, turn counterclockwise. Tighten by hand only. **DO NOT** use tools.

IMPORTANT!

TO ENSURE PROPER GAS FLOW, BURNER CONTROL VALVES MUST BE "OFF" BEFORE OPENING THE GAS CYLINDER VALVE.

3. Check that the cylinder valve is closed by turning the cylinder knob clockwise to a full stop (Fig. 41).

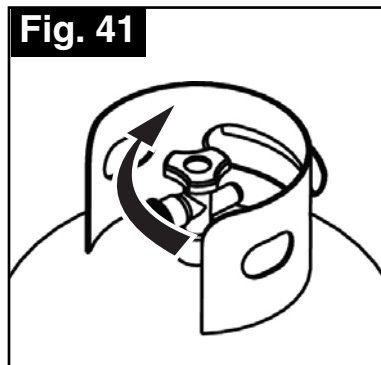

20# LP Cylinder Installation (continued)

4. Check that all grill burner knobs are in the off position (Fig. 42).



5. Remove the protective caps from the cylinder valve and coupling nut. NOTE: The coupling nut connects to the large outside threads on the valve outlet.

6. Hold the hose in one hand and insert the nipple into the valve outlet. Be sure the nipple is centered in the valve outlet. Hand-tighten the coupling nut, taking care not to cross-thread the connection (Fig. 43).



7. Turn the coupling nut clockwise, tighten to a full stop. If you cannot complete the final connection, disconnect the coupling nut and repeat steps 6 and 7. If you are still unable to complete the connection, DO NOT use this hose and valve!
8. Check that the hose has no kinks or sharp bends and clears areas that will become hot during use. Never put strain on the hose where it joins a fitting.
9. **BEFORE** lighting grill, check all connections for leaks using the procedure as shown in the section titled "LEAK TESTING".

Leak Testing - Refillable Cylinders

⚠ DANGER

To PREVENT FIRE OR EXPLOSION HAZARD:

- NO SMOKING. DO NOT use or permit sources of ignition in the area while doing a leak test.
- Perform leak tests outdoors only.
- NEVER perform a leak test with fire or flame.

How to Check for Leaks

1. Make a soapy solution of equal parts mild liquid dishwashing detergent and water.
2. Turn off all burner control knobs.
3. Turn on the fuel supply by turning the cylinder valve knob counterclockwise (right to left) one rotation.
4. Apply a soap solution to the connections indicated with the arrows in Fig. 44. If bubbles appear at these areas, a leak is indicated.

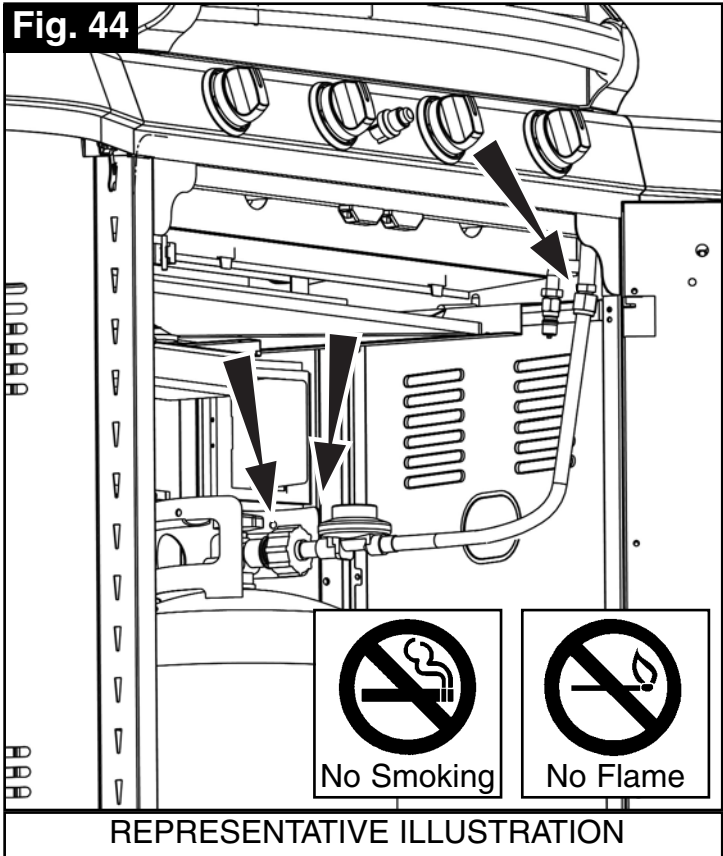

Fixing A Fuel Leak

If you detect a leak:

1. Turn off the fuel supply. Push in and turn on the control knobs to release pressure in the hose, then turn the control knobs back to off.
2. Wash off soapy solutions with cold water and towel dry.
3. Stop a leak by tightening the loose joint, or by replacing the faulty part with a replacement part recommended by Coleman. DO NOT attempt to repair the cylinder valve if it should become damaged; the cylinder MUST be replaced.
4. If you are unable to stop a leak, shut off the gas supply at the cylinder valve. Remove the cylinder from the grill. Call a gas appliance serviceman or L.P. gas dealer. DO NOT use grill until the leak is corrected.

When to test for leaks:

1. Perform a leak test each time the gas supply cylinder is connected to the hose end. Leak test anytime a part of the gas system is replaced.
2. Perform a leak test at least once each year whether the L.P. gas supply cylinder has been disconnected or not.
3. Have a dealer check the cylinder for deterioration after 12 years, according to DOT regulations. Immediately replace the cylinder if any deterioration is found.

CAUTION

Inspect the gas supply hose before each use. Look underneath the grill to inspect the hose assembly below the grill. If there are cuts, damage, excessive abrasion or wear, replace the hose prior to operating the appliance. During assembly of the grill and when attaching or replacing the L. P. gas cylinder, insure that the gas supply hose is free of kinks and/or damage and is at least three inches away from hot surfaces such as the grill housing. Use only hose replacements specified in the parts list.

Start-Up Check List

WARNING

Failure to follow these safety steps before using the grill each time could result in a fire that could be hazardous to you, your appliance or property. It is especially important to observe these steps after the grill has been stored, moved or cleaned.

- 1. Regularly check the burner venturi tubes for blockage from an insect nest. Read "Cleaning the Venturi" in the section titled "Care, Maintenance, and Cleaning", and also the section titled "Troubleshooting".
- 2. Check that all the burner venturi [H] are set over the valve outlets [J] correctly. The valve orifice [K] must be inside the venturi (Fig. 45).
- 3. Inspect the gas supply hoses before each use. Hoses can be burned or chafed if they are routed improperly. See that the hoses have no kinks, sharp bends or tension. Insure that the hoses are at least 3 inches away from any hot surface.
- 4. Use only the gas specified.
- 5. Keep the grill on a level surface.
- 6. Keep the grease pan empty at start up.

Fig. 45

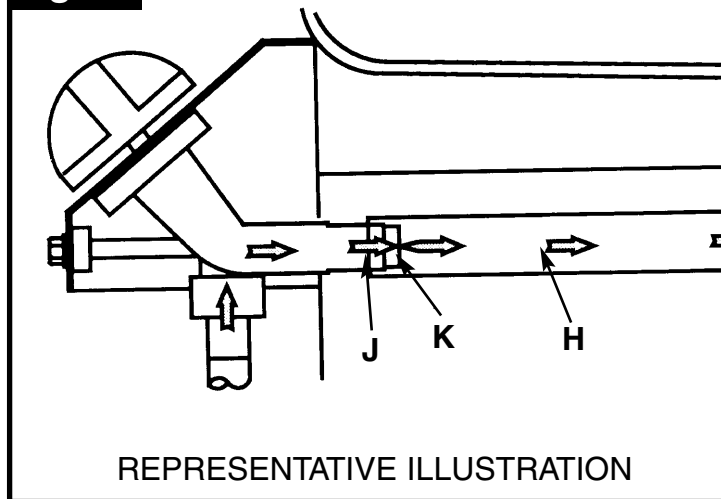

CAUTION

DO NOT add charcoal or lighting fluid!

Lighting Instructions

⚠ WARNING

THE FOLLOWING RULES MUST ALWAYS BE FOLLOWED IN THIS ORDER (Fig. 46):

1. OPEN THE GRILL LID! Any attempt to light the grill with the lid down could cause an explosion.
2. Check that the burner control knobs are turned to "OFF".
3. Turn on the fuel supply. For an L.P. gas cylinder, turn the top cylinder valve knob counterclockwise one rotation to open.
4. DO NOT stand with your head or arms over the grill.

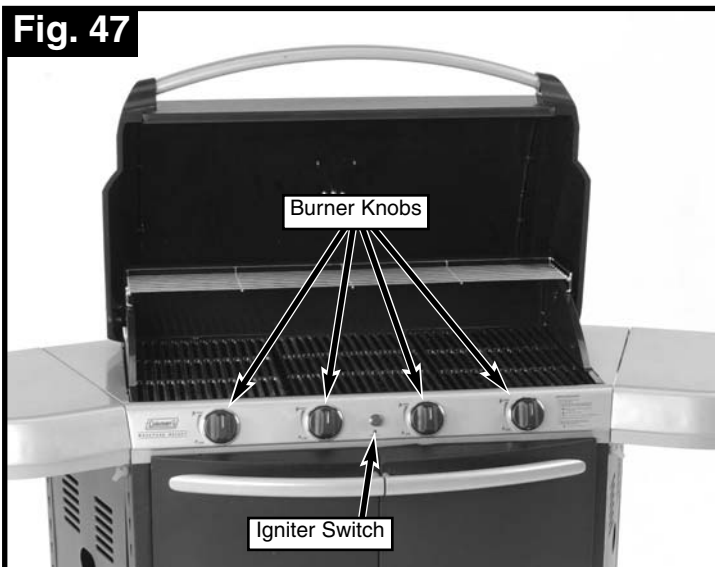
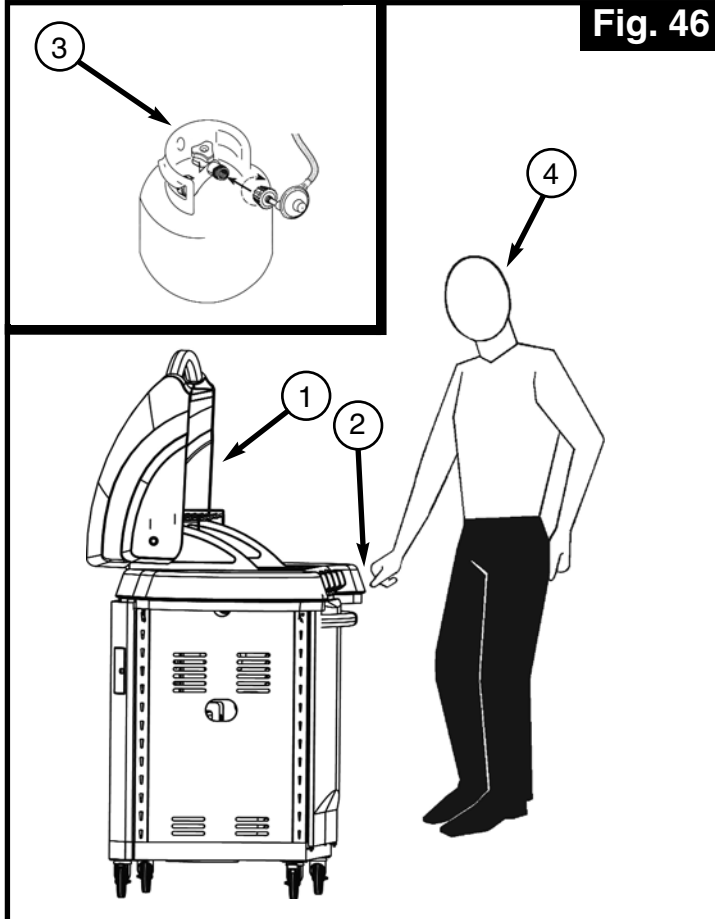

Lighting the Burners

1. Push and turn one of the main burner control knobs counterclockwise to the "HIGH" position. **Wait 5 seconds** (Fig. 47 and 48).
2. Push and hold the igniter button until burner lights. You will hear a snapping sound (Fig. 49).
3. If the burner does not light in 4 seconds, turn the control knob to OFF and wait 5 minutes for the gas to clear before trying again.
4. Repeat steps 1 through 3 to light the remaining burners.
5. If the burner does not light on the second try, turn the control knob to OFF and wait 5 minutes for the gas to clear, and then try match-lighting the burner.

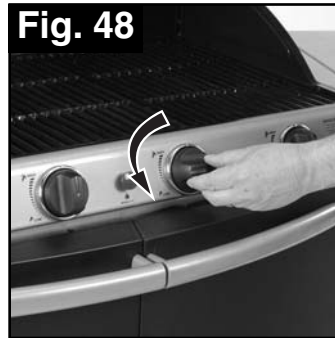

Match Lighting

1. Strike and place the burning long wooden match (or butane lighter with extension) through the spaces in the grill grates near the ports of the burner between the heat tents (Fig. 50).
2. Push and turn the control knob counterclockwise to the "HIGH" position.
3. Repeat steps 1 and 2 to light the remaining burners.

⚠ CAUTION

Use a LONG wooden match or a butane lighter with an extension. Make sure all burner controls are off except for the burner being lighted. If a long-reach match or lighter is not accessible, use the match extension. The match extension is located inside the doors. Insert a match in the holder end of the extension, strike and place the burning match near the BURNER being operated.



Shutting Off the Grill

⚠ CAUTION

DO NOT touch hot grill parts with your bare hands!
You MUST use protective gloves.

1. Turn all burner control knobs to off.
2. After the burner flame goes out, turn off the fuel supply. Turn the L.P. cylinder knob in a clockwise direction until it stops.

⚠ CAUTION

Be certain the gas is shut off at the L.P. cylinder valve anytime the grill is not in use.

General Use and Correct Burner Flames

⚠ WARNING

- Keep the grill area clean and free from combustible materials, gasoline and other flammable vapors, liquids, and spare L.P. cylinders.
- To avoid the possibility of tipping over the grill, NEVER place more than 10 pounds on the side table. A filled 4-quart aluminum pot weighs approximately 10 pounds.
- DO NOT obstruct the flow of combustion and ventilation air.
- Keep the ventilation opening(s) of the L.P. cylinder enclosure free and clear of debris.
- A barbecue grill becomes hot during use. DO NOT touch grates, or cooking surfaces.
- Be sure to tighten all hardware (screws, nuts, bolts, etc.) at least once a year or before each grilling season.

Condition The Grill

- Before using the grill for the first time, or after storage, operate the grill 15 minutes on the high setting with the lid closed, to burn away oil.
- Once the oil has burned away, check the burner flame per the next step.

The Burner Flame

- Open the grill lid. The cooking grates should be in place.
- Keep your arms and face away from being directly above the cooking area. Look through the cooking grates and observe the burner's flame below the heat tents.
- Flames should appear similar to the good flame shown in Fig. 51 and as follows:
- A good flame should be blue with a yellow tip.
- Some yellow tips on flames up to 1 inch in length are acceptable as long as no carbon or soot deposits appear.
- If flames are excessively yellow and irregular, the oil residue may not be completely burned off, or the venturi may be clogged or may not be properly positioned over the orifices. Allow the grill to cool before repositioning the venturi over the valve and orifices.

The Burner Flame (continued)

- Grills that have been in use for a while sometimes begin to show more yellow flame. A build-up of food deposits, fats or cooking seasonings can cause yellowing flames. Clean the burner to remove residue and check for clogged burner holes or a blocked venturi. Refer to the section titled "Cleaning the Venturi".
- Regular use of your grill will actually help keep it operating more smoothly.
- Each grill may heat differently. Some units will heat somewhat more to the center and back of the grill. The flavor of grilled food will improve the more you use the grill and as you become familiar with it.

Fig. 51

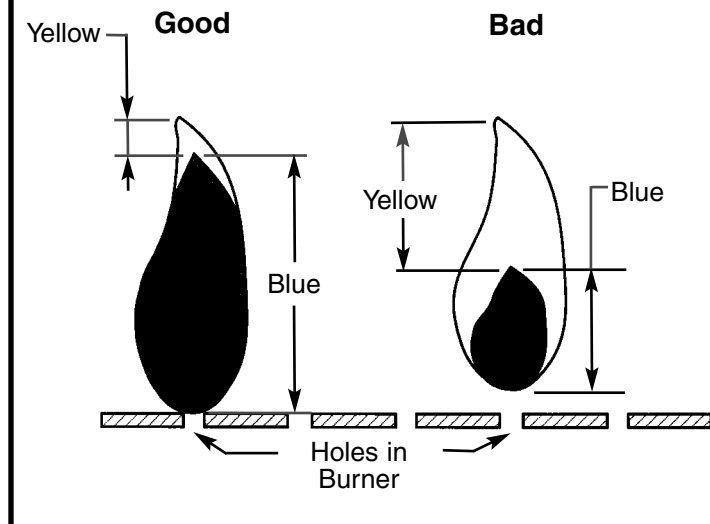

Grilling Tips and Hints

Burner Control Setting Tips

- The high flame setting is too hot for direct cooking. The high flame setting is good for quick searing of meat, then finish cooking on medium or low flame settings.
- Use the high flame setting with the lid closed to preheat the grill for 5 minutes before cooking and with the lid closed for a maximum of 5 minutes after cooking to burn off grease drippings.
- Use a medium flame setting for direct cooking of steaks, pork chops, chicken and hamburgers.
- Use a low flame setting for roasts and rotisserie foods.
- Thick steaks will finish with a better texture and more juice if first seared on high flame setting and then cooked on a low flame setting.

Safe Grill Operation

- NEVER leave cooking food unattended. Continually observing the food will help in maintaining an even temperature, conserve fuel, improve the food's flavor and lessen flare-ups.
- To open the grill lid, slowly lift the handle to avoid burning in case of a grease fire flare-up.
- DO NOT expose any part of your body directly above the cooking area.

Food Preparation Hints

Your grill can cook a variety of foods. For best results, follow these instructions:

- Trim excess fat from meat and poultry. Slash any remaining fat to stop curling, but take care not to cut the meat.
- Frozen meat and poultry should be thawed prior to cooking.
- Frozen fish and vegetables will cook without thawing.
- Salt food after cooking to help prevent drying out the food.
- Brush naturally lean meats with cooking oil or margarine.
- Cook small pieces of tender foods in foil or on special delicate-food cooking grates (see the section titled "Cooking Methods").
- Apply barbecue, tomato or sugar-based sauces no sooner than the last 10 minutes of cooking.
- Turn food with tongs or a spatula; piercing food (especially meat), tends to dry it out.

In Case of Grease Fire

Follow These Steps:

1. Shut off the gas at the burner valve(s) and stay away!
2. Allow the fire to burn itself out.
3. Once the fire is out and the appliance has cooled, shut off the L.P. cylinder valve.
4. Clean all parts and inspect for damage. Parts to check for damage are the L.P. cylinder, cylinder valve, regulator, gas supply hose, burner valve(s) and burner(s).
5. If any of the above mentioned components are damaged, seek replacement from Coleman before operating the grill again. Locate your nearest service center by calling 1-800-356-3612.

Note:

- Some flare-up adds a smoky flavor and sears food. Excessive grease fires can cause a potentially hazardous situation and damage the grill.
- Avoid excessive flare-ups by preheating the grill with the lid closed for 5 minutes on the high setting to burn off grease from previous cooking.
- Cook with the lid down and continually monitor cooking food to avoid grease fires and flare-ups.
- Trimming excess fat from meat will reduce grease fires and flare-ups. Cook fatty meat in smaller amounts over indirect heat on a low setting.
- Be sure to follow the instructions in the section titled "Care, Maintenance, and Cleaning".

Cooking Methods

Direct Method:

- The heat source is directly below the food.
- Use for browning meat or cooking hot dogs and hamburgers, but check food frequently.
- Use for skillet and stir-fry cooking, but limit the amount of oil and heat to be used.
- Cook roasts, turkey or duck on low heat. Place meat with water in a foil pan with a corrugated bottom. Replenish water as needed.

Indirect Method:

- Light only one side of the burner and place food on the opposite side for cooking.
- Allow food to cook at a lower temperature which increases tenderness and reduces grease flare-ups.
- It is a good method for cooking foods that burn easily (vegetables, fish, etc.).
- Cook casseroles in ovenware or foil pans much like cooking in a conventional oven.
- Also try placing a pan of water above the lit burner side to help meat retain its juices. Replenish the water as needed.

Care, Maintenance and Cleaning

DRIP TRAY

The drip tray is located below the grill and should be cleaned periodically to prevent heavy buildup of debris.

NOTE: Allow the drip tray to cool before attempting to clean.

Important: Do not leave the grill outside during inclement weather unless it is covered (cover sold separately). Rain water can collect inside of the grill, the grill cart or the drip tray if left uncovered. If the drip tray is not cleaned after use and the grill is left uncovered, the drip tray will fill with water causing grease and water to spill into the grill cart. We recommend cleaning and storing the drip tray after every use.

COOKING GRATES

The cooking grates can be cleaned immediately after cooking is completed and after turning off the grill. Wear a barbecue mitt and scrub the cooking grates with a damp cloth. If the grill is allowed to cool down, cleaning the grates will be easier if removed from the grill and cleaned with a mild detergent.

STAINLESS STEEL

After initial usage, areas of the grill may discolor from the intense heat given off by the burners, this is normal and not considered a defect.

Purchase a mild stainless steel cleaner and rub in the direction of the grain of the metal. Specks of grease can gather on the surface of the stainless steel and bake on to the surface and give a worn appearance. For removal, use a non-abrasive oven cleaner in conjunction with a stainless cleaner.

NOTE: Always scrub in the direction of the grain.

BATTERY REPLACEMENT (FOR IGNITER):

The igniter is powered by a standard 9 Volt battery. To replace the battery, locate the igniter module by opening the left side door. The igniter module is located near the top edge of the left side panel. When installing a fresh battery, observe polarity as marked on the igniter module and push in firmly (Fig. 52).

Fig. 52

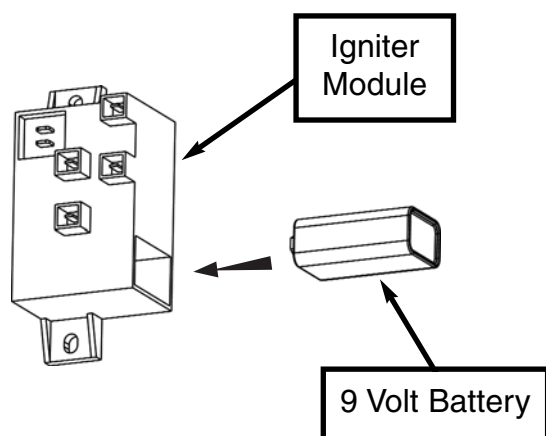

CAUTION

All cleaning and maintenance should be done only when the grill is cool & with the fuel supply turned off at the cylinder.

Suggested Cleaning Materials:

- Mild dishwashing liquid detergent
- Hot water
- Wire brush
- Paper clip
- Nylon cleaning pad
- Soft brass-bristled brush
- Putty knife
- Scraper

Component Cleaning:

- **BURNER:** Wire-brush loose corrosion from the burner exterior. Clean clogged gas port holes with an opened paper clip. Replace corroded or damaged burners that would emit excess gas.
- **STAINLESS STEEL:** Clean with any multipurpose (low abrasive, non phosphorous) metal polish or stainless steel polish and a soft cloth to prevent marring or scratching the surface. **NEVER USE OVEN CLEANER!**
- **COOKING GRATES:** Clean cooking grates with mild soap and hot water. Remove stubborn residue with a mild cleanser or scrub brush. **DO NOT** use a commercial oven cleaner.
- **HEAT TENTS:** Wipe off grease residue using a cleaning pad and a brass-bristle brush to knock off residue. Replace heat tents to their correct position.
- **GRILL INTERIOR:** Remove grates and heat tents. Scrape side with tools and remove excess grease and cooking residue.

Cleaning the Venturi

WARNING

Spider's nests or wasp's mud inside the venturi may cause fire at the valve. If a fire occurs, immediately turn off the gas supply at the L.P. cylinder valve (see representative illustration in Fig. 53).

Fig. 53

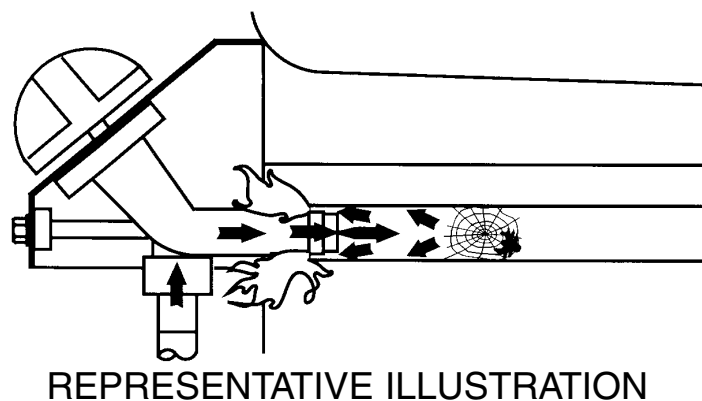

Note:

Spiders and small insects can spin webs and build nests inside the venturi tubes. This especially occurs in late summer and fall before frost when spiders are most active. These nests can obstruct gas flow and cause a fire in and around the burner valves. Such a fire can cause operator injury and serious damage to the grill. To help prevent a blockage and ensure full heat output, clean and inspect the venturi tubes often (once or twice a month). **NOTE:** Water or air pressure will not normally clear a spider web.

Steps For Cleaning Venturi:

1. To remove the above obstructions, use an accessory flexible venturi brush or bend a small hook on one end of a 20-inch long flexible wire such as the one shown in Fig. 54.

Fig. 54

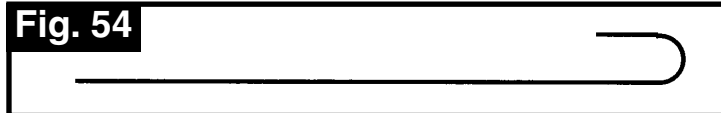

2. Remove the cooking grates and heat tents and set aside. Using a screwdriver, remove the single screw holding each burner tube. There is a hex nut under each burner bracket. It is necessary to hold the hex nut when removing the screw. Lift the burner tube away from the valve and remove from the grill. Repeat for the other burners and set aside (Fig. 55).

Fig. 55

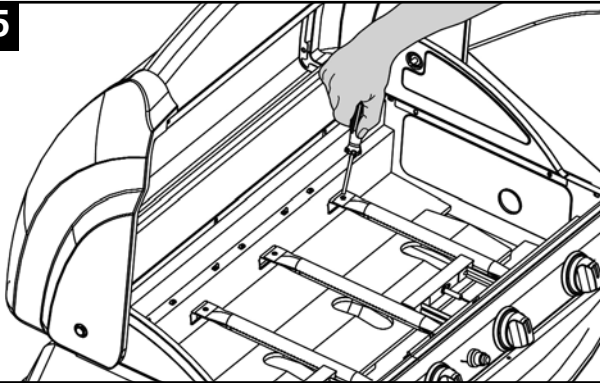

REPRESENTATIVE ILLUSTRATION

3. Look inside end of venturi tubes for nests, webs or mud. If present, clean as shown in Step 1, Fig. 54.
4. Inspect and clean the burner if needed.
5. Replace the burners in the operating position.
6. Make sure the venturi is properly positioned on the burner tube, and that the venturi is properly positioned over the valve orifice (Fig 56).

Fig. 56

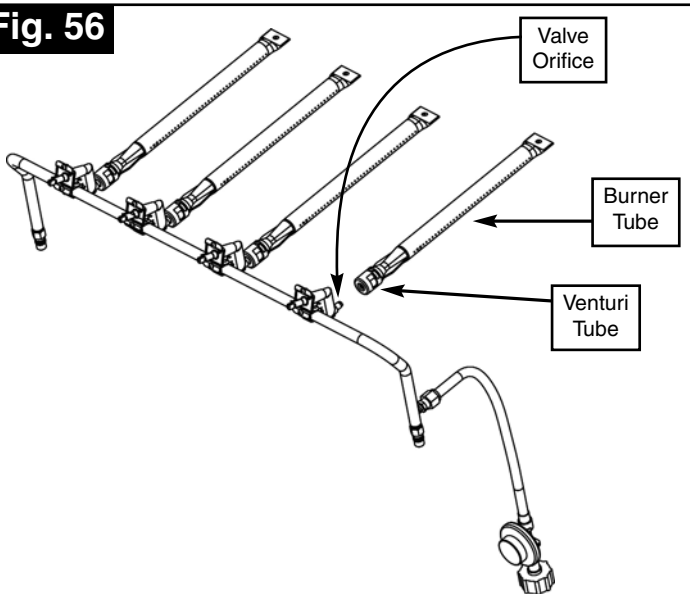

REPRESENTATIVE ILLUSTRATION

7. Reinstall the burners, heat tents and the cooking grates.

Moving and Storage

⚠ CAUTION

A collision with the grill, as with any metal object, could cause injury. Use care when moving a portable gas grill.

Moving the grill:

- Move the grill slowly. DO NOT run with or pull the grill behind you; it could hit you from behind causing injury.
- DO NOT move the grill while it is lit or hot, or with objects on the cooking surface(s) or side table(s).

After moving the grill:

- Check all gas connections for leaks that could occur from the movement.
- Check the venturi tubes to be sure they are still over the orifices.

Steps to follow before storing grill:

- Clean the grill.
- Coat the burner lightly with cooking oil to retard rusting.
- For outdoor use only. If the grill is stored indoors, detach and leave the cylinder outdoors. If left outdoors, turn off the fuel supply to the L.P. cylinder and cover the grill for protection from the weather. Grill covers may be purchased from a grill dealer or manufacturer.

⚠ WARNING

If the grill is not in use, the gas MUST be turned off at the fuel supply cylinder.

Place the dust cap on the cylinder valve outlet whenever the cylinder is not in use. Only install the type of dust cap on the cylinder valve outlet that is provided with the cylinder valve. Other types of caps or plugs may result in leakage of propane.

Troubleshooting

Problem: Grill will not light when the Igniter button is pushed or has incomplete burner flame.

Possible Causes and Solutions:

1. Dead Battery. Install a fresh 9 volt battery in the electrode module.
2. Lack of fuel. Check to see that the cylinder valve is open and the cylinder has fuel.
3. Make sure one of the burners is turned on. Allow up to five seconds for gas flow to ignite.
4. If burner lights with match but not Igniter, check the ceramic electrode position near the burner, the condition of the Igniter wire and its connections. Perform Igniter test and replace any damaged parts.
5. Check for spider webs or insect nest in venturi and clean venturi.
6. Misalignment of venturi on orifices. Position venturi over orifices.
7. Burner ports, orifices, valves or hose have blockage. Clean the components.
8. Crimped fuel supply hose needs straightened.
9. Regulator failure or damaged hose need to be replaced by an authorized service dealer.
10. Make sure the hose to the cylinder is properly assembled. See the section titled "Connecting Type 1 L.P. Gas Cylinders".

Problem: Yellow flame.

Possible Causes and Solutions:

1. Check for spider webs or insect nest in the venturi and clean the venturi.
2. Clean off any food residue, grease or seasoning salts on the burner.
3. Air may be in the cylinder if the cylinder was not properly purged. Use up remaining gas; the yellow flame may disappear with use.
4. The venturi may be misaligned and needs to be lined up over the orifice.

Troubleshooting (continued)

Problem: Flame blows out on low setting or has uneven heat distribution.

Possible Causes and Solutions:

1. Check for spider webs or insect nests in the venturi and clean the venturi.
2. Cold grill needs to be preheated for 5 minutes on high setting.
3. The venturi may be misaligned and needs to be lined up over the orifices.
4. Cold and windy weather will require you to move the grill away from the wind.
5. Lack of fuel. Check to see that the cylinder valve is open and that the cylinder has fuel.

Problem: Grill too hot.

Possible Causes and Solutions:

1. Excessive flareups which require the maintenance described in the section titled "IN CASE OF GREASE FIRE".
2. A damaged orifice or regulator which requires replacement with factory authorized parts.
3. Buildup of grease inside the grill will require cleaning and emptying the grease tray.
4. Choose a lower cooking temperature if using excessively high settings.

Problem: Fire at any connection.

Possible Causes and Solutions:

IMMEDIATELY shut off cylinder valve and allow grill to cool.

1. Gas is leaking from a faulty connection. Tighten connections with an adjustable wrench and replace damaged parts. Perform a leak test on all connections before cooking on the grill again.

Problem: Flame behind control panel or control knob area.

Possible Causes and Solutions:

IMMEDIATELY shut off cylinder valve and allow grill to cool.

1. Check for spider webs or insect nest in the venturi and clean the venturi.
2. Gas is leaking from a faulty connection. Tighten connections with an adjustable wrench and replace damaged parts. Perform a leak test on all connections before cooking on the grill again.
3. The venturi may be misaligned and needs to be lined up over the orifices.

⚠ DANGER

If a fire occurs at the cylinder valve, **DO NOT** attempt to move the cylinder. **IMMEDIATELY** call the fire department and clear the area.

For Your Additional Safety

Current refillable L.P. gas cylinders are fitted with an Overfill Protection Device (O.P.D.). To insure that you retain this safety-device, take your cylinder to an L.P. gas service station for filling, or when exchanging your cylinder at a cylinder exchange station, request that your replacement cylinder be fitted with the O.P.D. feature.

YOUR NEW GAS GRILL IS EQUIPPED WITH A TYPE 1 CONNECTION DEVICE WHICH HAS 3 SAFETY FEATURES (FIG. 57):

1. Proof of gas seal between the connector and the cylinder before gas flow takes place.
2. A flow-limiting device designed to limit the flow of gas in the event of a regulator or hose failure.
3. The connection has a thermal shut-off which will stop the flow of gas if the connection reaches a certain temperature.

Fig. 57

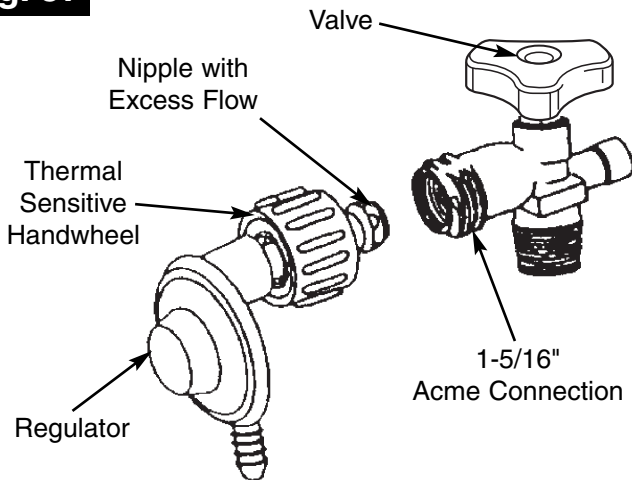

TYPE 1 CONNECTION ILLUSTRATION

For Your Additional Safety (continued)

CURRENT GAS CYLINDERS ARE ALSO EQUIPPED WITH AN OVERFILL PROTECTION DEVICE (O.P.D.) WHICH GREATLY REDUCES THE CHANCE OF ACCIDENTALLY OVERFILLING THE CYLINDER.

SPECIAL NOTE CONCERNING L.P. GAS CYLINDERS:

It is important to insure that your gas cylinder is properly purged before it is filled. If you purchase a new cylinder, please inform your propane gas dealer that this is a new cylinder and needs to be properly purged before being filled.

SPECIAL NOTE CONCERNING TYPE 1 CONNECTION DEVICES:

If you notice very small flames on the burner(s), you may have accidentally activated the flow-limiting device in the Type 1 connection device. Besides a rupture in the gas hose, the flow-limiting device may activate for one of the two following reasons:

1. Opening the burner valves before opening the cylinder valve. SOLUTION: Shut off the burner valves and the L.P. cylinder valve and open in the proper order:
 - a). Open the L.P. cylinder valve first, then
 - b). Open burner valve and ignite the burner according to the instructions in this manual for your grill.

IF YOU STILL HAVE A PROBLEM, THEN THERE MAY BE AIR IN THE CYLINDER DUE TO IMPROPER PURGING.

2. The L.P. cylinder was not properly purged before it was filled. SOLUTION: See your L.P. gas supplier.

ATTN: DEPT 586

PRODUCT REGISTRATION DEPARTMENT
PO BOX 2931
WICHITA, KS 67201



Please
Place
First-Class
Stamp
Here

Please do not send other
correspondence to the address below.

PLEASE FOLD AND SEAL WITH TAPE. DO NOT STAPLE.

Coleman® Grill Warranty Registration Card



IMPORTANT!

**COMPLETE THE ATTACHED REGISTRATION CARD AND RETURN WITHIN 10
DAYS TO RECEIVE THESE IMPORTANT BENEFITS:**

- ▶ **CONFIRM YOUR WARRANTY:**
Your prompt product registration confirms your right to the protection available under the terms and conditions of your Coleman® warranty.
- ▶ **PROTECT YOUR PRODUCT:**
We will keep the model number and date of purchase of your new Coleman® product on file to help you refer to this information in the event of an insurance claim such as fire or theft.
- ▶ **PROMOTE BETTER PRODUCTS:**
We value your input. Your responses will help us develop products designed to best meet your needs.

Replacement Parts List — 9998 Series

No.	Part Number	Description
1	9998-1551	Thermometer Assembly
2	9998-5021	Lid Handle Assembly
3	9998-5631	Lid Assy Complete
4	"Please Call"	Hood Hinge Pin
5	9998-1261	Hood Cotter Pin
6	9998-1541	Hood Bumper Pads (2 pk)
7	9998-1531	Warming Rack
8	9998-1731	Grill Grate
9	9998-1661	Heat Tent
10	9998-1651	Burner Assembly
11	"Please Call"	Electrode/wire Assembly
12	"Please Call"	Side Table Complete
13	9998-1371	Pulse Igniter
14	9998-5161	Grease Tray Assembly
15	9998-1861	Grease Tray Pan
16	9998-1891	Grease Tray Liner
17	9998-4311	Caster
18	9998-4051	Caster With Lock
19	"Please Call"	Door Assembly Right
20	"Please Call"	Door Assembly Left
21	9998-5551	Door Handle Assembly
22	9998-5251	Regulator Assembly
23	9998-1491	Knob
24	9998-1401	Knob Bezel

Unless noted otherwise,
all repair parts listed are
for one item only.

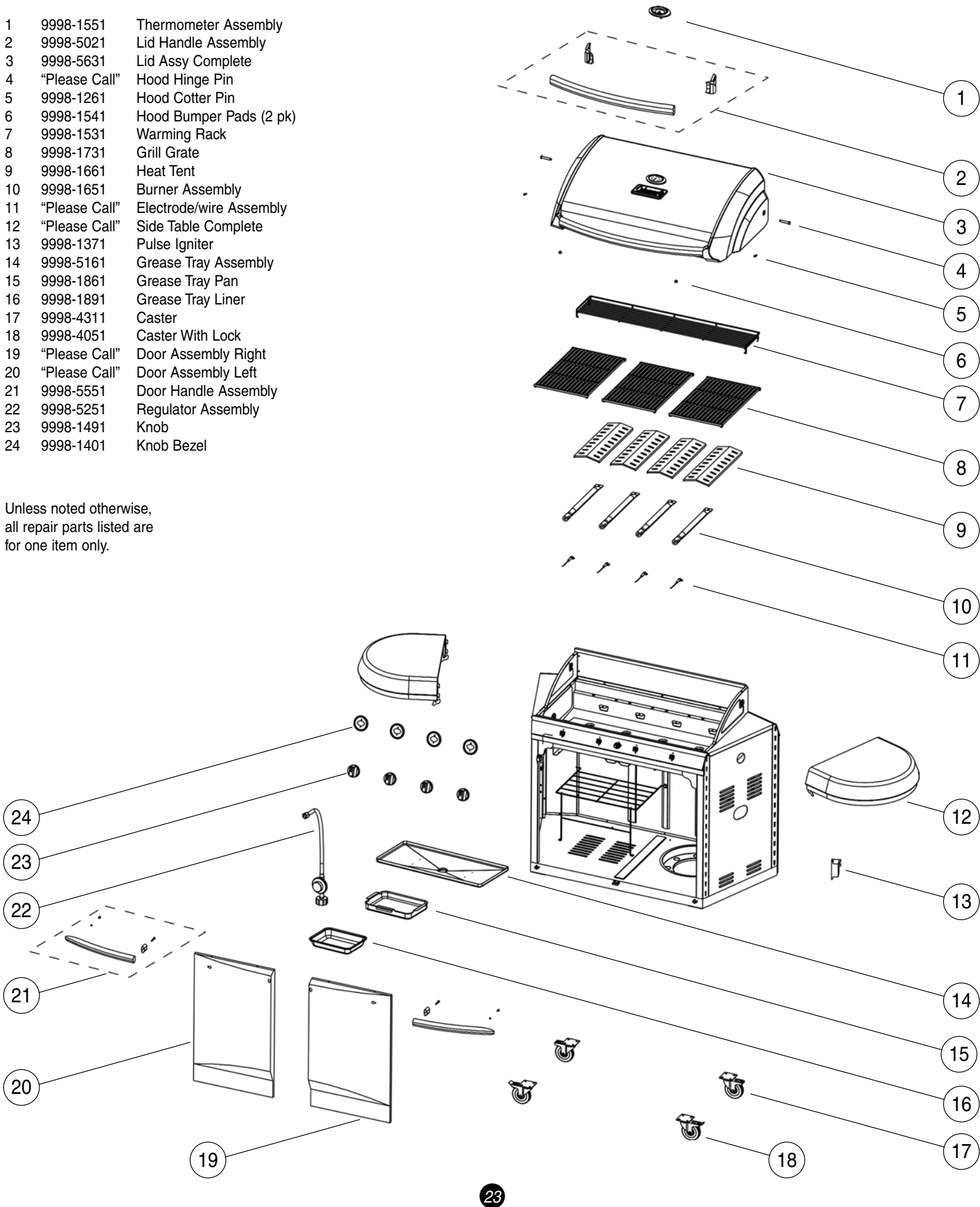

Limited Three Year Warranty

The Coleman Company, Inc. ("Coleman") warrants that for a period of three years from the date of original retail purchase, this product will be free from defects in material and workmanship. Coleman, at its option, will repair or replace this product or any component of the product found to be defective during the warranty period. Replacement will be made with a new or remanufactured product or component. If the product is no longer available, replacement may be made with a similar product of equal or greater value. This is your exclusive warranty.

This warranty is valid for the original retail purchaser from the date of initial retail purchase and is not transferable. Keep the original sales receipt. Proof of purchase is required to obtain warranty performance. Coleman dealers, service centers, or retail stores selling Coleman® products do not have the right to alter, modify or in any way change the terms and conditions of this warranty.

What This Warranty Does Not Cover

This warranty does not cover normal wear of parts, parts that are not genuine Coleman® parts, or damage resulting from any of the following: negligent use or misuse of the product; use on improper voltage or current; commercial use of the product; use contrary to the operating instructions; disassembly, repair or alteration by anyone other than Coleman or an authorized service center. Further, the warranty does not cover Acts of God, such as fire, flood, hurricanes and tornadoes. Warranty void if damage to product results from the use of a part other than a genuine Coleman® part.

COLEMAN SHALL NOT BE LIABLE FOR DEFECTS THAT ARE CAUSED BY THE USE OF UNAUTHORIZED PARTS OR SERVICE. COLEMAN SHALL NOT BE LIABLE FOR ANY INCIDENTAL OR CONSEQUENTIAL DAMAGES CAUSED BY THE BREACH OF ANY EXPRESS OR IMPLIED WARRANTY OR CONDITIONS. EXCEPT TO THE EXTENT PROHIBITED BY APPLICABLE LAW, ANY IMPLIED WARRANTY OF MERCHANTABILITY OR FITNESS FOR A PARTICULAR PURPOSE IS LIMITED IN DURATION TO THE DURATION OF THE ABOVE WARRANTY OR CONDITIONS. SOME STATES, PROVINCES, OR JURISDICTIONS DO NOT ALLOW THE EXCLUSION OR LIMITATION OF INCIDENTAL OR CONSEQUENTIAL DAMAGES OR LIMITATIONS ON HOW LONG AN IMPLIED WARRANTY LASTS, SO THE ABOVE LIMITATIONS OR EXCLUSION MAY NOT APPLY TO YOU. THIS WARRANTY GIVES YOU SPECIFIC LEGAL RIGHTS, AND YOU MAY ALSO HAVE OTHER RIGHTS THAT VARY FROM STATE TO STATE OR PROVINCE TO PROVINCE.

How to Obtain Warranty Service

Take the product to an authorized Coleman service center. You can find the nearest authorized Coleman service center by visiting www.coleman.com or calling 1-800-356-3612 or TDD 316-832-8707 in the United States or 1 800 387-6161 in Canada. If a service center is not conveniently located, attach to the product a tag that includes your name, address, daytime telephone number and description of the problem. Include a copy of the original sales receipt. Carefully package the product and send either by **courier** or **insured mail** with shipping and insurance prepaid to:

For products purchased in the United States:
The Coleman Company, Inc.
3600 North Hydraulic
Wichita, KS, 67219

For products purchased in Canada:
Sunbeam Corporation (Canada) Limited • DBA Jarden Consumer Solutions
20B Hereford Street
Brampton, ON L6Y 0M1

This warranty does not include transportation or shipping costs. If you ship your product, shipping and insurance must be prepaid.

DO NOT RETURN THIS PRODUCT TO THE PLACE OF PURCHASE.

If you have any questions regarding this warranty please call 1-800-356-3612 or TDD 316-832-8707.

For Warranty, Service and Parts
Locate your model number and serial number on the
label found on the grill.



The Coleman Company, Inc. • 3600 North Hydraulic • Wichita, KS 67219 U.S.A. • 1-800-356-3612 • TDD: 316-832-8707
Sunbeam Corporation (Canada) Limited • DBA Jarden Consumer Solutions • 20B Hereford Street • Brampton, ON L6Y 0M1 • 1 800 387-6161

©2007 The Coleman Company, Inc. All rights reserved.
Coleman® and  are registered trademarks and Side Solution™ is a trademark of The Coleman Company, Inc.

4010001333 (20070620)