

This Owner's Manual is provided and hosted by Appliance Factory Parts.

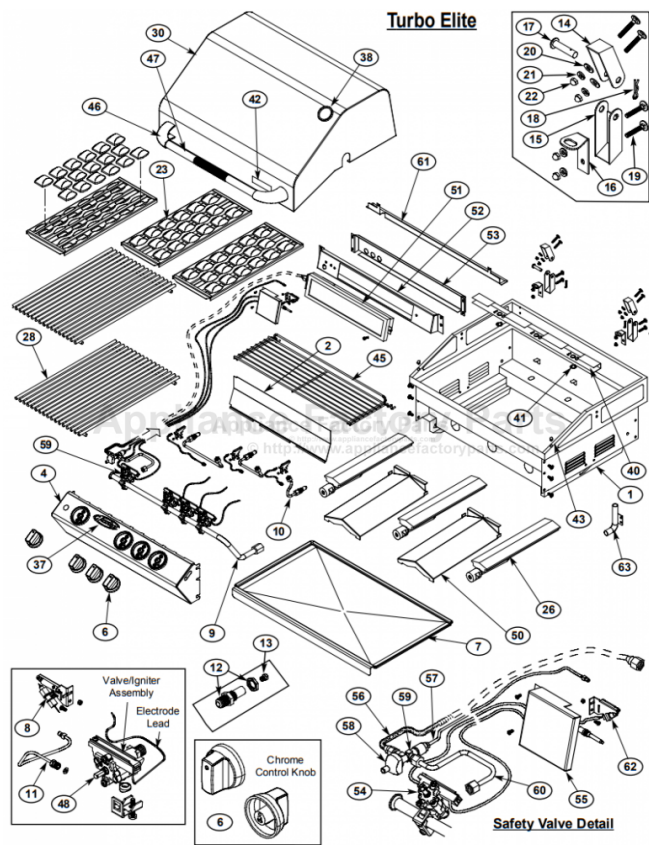

Turbo CG3TDBRN Owner's Manual

[Shop genuine replacement parts for Turbo CG3TDBRN](#)



[Find Your Turbo Grill Parts - Select From 93 Models](#)

----- Manual continues below -----



Instruction Manual For Models

CG3TCBN, CG3TDBRN

CG4TCBN, CG4TDBRN

CG5TCBN, CG5TDBRN

Note: We highly recommend you always cover this barbecue when it is not in use which will prolong the life of the barbecue and protect it from the elements.

FOR YOUR SAFETY, IF YOU SMELL GAS :

- | | |
|---|---|
| 1. Shut off gas to the appliance. | 5. Do not store or use gasoline or other flammable vapors and liquids in the vicinity of this or any other appliance. |
| 2. Extinguish any open flame. | |
| 3. Open lid. | |
| 4. If odor continues, immediately call your gas supplier. | 6. An LP cylinder not connected for use should not be stored in the vicinity of this or any other appliance. |

⚠ WARNING

Failure to comply with these instructions could result in a fire or explosion that could cause serious bodily injury, death, or property damage.

All barbecues and carts are designed for outdoor use only!

All barbecues are not intended for commercial use.

This outdoor gas grill is not intended to be installed in or on recreational vehicles and/or boats.



America's Barbecue Grill Superstores

NOTE TO INSTALLER:

Leave these instructions with the consumer for future reference.



Design Certified
Unit approved by

CSA Laboratories under standard
ANSI Z21-58b-2002/CGA 1.6b-2002

Safety Information

WARNING

Fuels used in gas or oil-fired appliances and the products of combustion of such fuels, contain chemicals known to the State of California to cause cancer, birth defects and/ or other reproductive harm.

This warning is issued pursuant to California Health & Safety Code Sec. 25249.6.

You have bought a quality gas product from Barbeques Galore. All gas products require careful installation and or assembly and pre-operational testing. We recommend that our trained staff assemble, test and if necessary install your new purchase for you.

Barbeques Galore cannot be held responsible for any damages to persons or property resulting from improper assembly or installation.

If you chose to assemble, test and install your own unit, please follow the manufacturer's instructions explicitly.

This Outdoor Cooking Gas Appliance is not intended to be installed in or on recreational vehicles and/or boats.

GAS PRESSURE

This propane grill is designed to operate on propane at a gas pressure regulated at 11" water column (W.C.) when equipped with the correct Propane Orifices on the valves and a **Propane Regulator** on the supply line. The Natural Gas Grill is designed to operate on Natural Gas at a gas pressure regulated at 4" water column (W.C.) when equipped with the correct Natural Gas Orifice on the valves and a **Natural Gas Regulator** on the supply line.

GENERAL INFORMATION

The installation of your Gas grill must meet all local codes and/or gas utility requirements or, in the absence of local codes, with the National Fuel Gas Code, ANSI Z223.1.

CAUTION: LEAK CHECKING

Check all gas connections with a soap solution to be sure they are tight and leakproof. To make soap solution, mix one part water with one part liquid detergent. With heat control knobs at "OFF position, turn gas supply on. Apply the mixture to all gas pipe connections. Soap bubbles will appear if connections are not properly sealed; repair as necessary. Never test for gas leaks with a lighted match or open flame.

Self-contained Propane Gas System -Mobile Cart

The Self-Contained Gas System Gas grill is designed to be used with a standard 20 lbs. gas cylinder. Do not connect to a Propane gas cylinder exceeding this capacity. The cylinder should not exceed 18 inches in height and 12 inches in diameter, and must be constructed and marked in accordance with specifications of the U.S. Department of Transportation for Propane gas cylinders.

The cylinder must also be equipped with:

- A) A collar to protect the Propane gas valve.
- B) A shutoff valve terminating a Propane gas cylinder valve outlet **QCC-1** (Quick Connect Coupling Type 1) as specified in the American National Standard for Compressed Gas Cylinder Valve Outlets and Inlet Connections, ANSI Z.21-58.

- C) A safety relief valve having direct communications with the vapor space of the cylinder;
- D) An arrangement for vapor withdrawal; and
- E) A bottom rim with holes for securing tank support assembly.

Propane is safe to use when properly handled, careless handling of the Propane gas cylinder could result in a fire and/or an explosion. Therefore:

- A) Always keep cylinder securely fastened in an upright position.
- B) Avoid tipping cylinder on its side when connected to a regulator since this may cause damage to diaphragm in regulator.
- C) Handle tank valves with care.
- D) Never connect an unregulated Propane gas cylinder to the grill.
- E) Do not subject Propane cylinders to excessive heat.
- F) Tightly close the gas shut-off valve on the Propane gas cylinder after each use.
- G) The QCC-1 Fitting must be protected when disconnected from the Propane tank. If fitting is allowed to drag on the ground, nicks and scratches could occur resulting in a leak when connected to the tank. Retain and use the plastic protector cap provided.

H) CAUTION:

Never store a Propane gas cylinder inside a building or in the vicinity of any gas burning apparatus. Between cookouts, when the Propane gas supply cylinder is not disconnected from the Gas grill, the cylinder and grill must be stored outdoors in a well ventilated area, out of the reach of children. If for any reason the Gas grill is to be stored indoors, the cylinder must be disconnected and removed from the grill cart and stored outdoors in a well ventilated area out of the reach of children. The plastic cylinder valve plug supplied with your Barbecue must be tightly installed when the cylinder is disconnected from the unit. **THE DISCONNECTED CYLINDER MUST NEVER BE STORED IN A BUILDING, GARAGE OR ANY OTHER ENCLOSED AREA.**

WARNING

Your grill will get very hot. Never lean over the cooking area while using your grill. Do not touch cooking surfaces, grill housing, grill lid or any other grill parts while the grill is in operation, or until the grill has cooled down after use.

Failure to comply with these instructions may result in serious bodily injury.

The LP gas pressure regulator and hose assembly supplied with this unit must be used without alteration. If this assembly needs to be replaced, use only the type specified by Barbeques Galore for this appliance.

When connecting the LP gas regulator to the supply cylinder, please remember that the threaded fittings on the QCC-1 valve tightens clockwise (**Figure 1**). This connection must be tightened fully to prevent leakage.

- I) If your Propane tank should ever require repainting use a light colored paint to allow heat reflection. Never use a dark color to repaint the Propane tank.

This appliance is for outdoor use in a well-ventilated area only. This unit must not be used in a building, garage or any other enclosed area.

BUILT-IN UNITS UTILIZING NATURAL GAS

When connecting a built-in unit to the natural gas supply in your home, please ensure the pipe joint compound is resistant to the action of natural gas. In addition, please observe the following:

The barbecue and its individual shut-off valve must be disconnected from the gas supply piping system during any pressure testing of that system at test pressures in **excess** of ½ psi (3.5 kPa).

The barbecue must be isolated from the gas supply piping system by closing its individual manual shut-off valve during any pressure testing of the gas supply piping system at test pressures **equal to or less than** ½ psi (3.5 kPa)

The units are supplied from the factory equipped for use with natural gas and includes a natural gas regulator. If operation with propane gas is desired, simply follow the instructions found on **page 4** of this manual. In addition, a **propane gas regulator MUST** be installed in the gas supply line from the propane gas tank.

Please remember to check all gas connections for leaks after the piping is completed. Follow the procedure found on **page 2**, under the heading "**CAUTION: LEAK CHECKING.**"

CAUTION: ELECTRICAL WARNING

If your grill incorporates electrical components they must be installed in accordance with local codes or in the absence of local codes, with the **National Electrical Code, ANSI/NFPA No.70-1987.**

The electric cord for the optional rotisserie motor is equipped with a three-prong 115v plug, and must be used with a grounded outlet. If it is not designed for a three wire plug, you must obtain an adapter and properly ground it before using the rotisserie. Do not cut or remove the grounding prong from the plug.

KEEP ANY ELECTRICAL SUPPLY CORD AND THE FUEL SUPPLY HOSE AWAY FROM ANY HEATED SURFACE.

Barbeques Galore Limited Warranty

Barbeques Galore hereby warrants to the ORIGINAL PURCHASER of this Barbeques Galore Gas Barbecue that it will be free of defects in material and workmanship from the date of purchase as follows:

Porcelainized Cast Iron Grills, Steel and Wood Carts	2 years
Porcelainized Steel Frame, Housing, Solid & Porcelain Coated Cast Iron Burners	5 years
Solid Cast Stainless Steel Burners	15 years
All Stainless Steel exterior parts.....	15 years
Painted BBQ Frames, Igniter Assemblies and All Remaining Parts	1 year

...when assembled and operated in accordance with the printed instructions that accompany it.

High cooking temperatures, excessive humidity, chlorine, fertilizers, lawn pesticides and salt can affect the Stainless Steel components and for these reasons, the limited warranties DO NOT COVER DISCOLORATION OR RUST, unless there is a loss of structural integrity on the grill component.

Barbeques Galore shall not be liable under this or any implied warranty for incidental or consequential damages and Barbeques Galore's liability is limited to the purchase price of this barbecue. This warranty gives you specific legal rights, and you may also have other rights which vary from state to state. This warranty is applicable in the United States and Canada. No one else is authorized to perform any obligations under this warranty.

Barbeques Galore requires reasonable proof of your date of purchase. THEREFORE YOU SHOULD RETAIN YOUR SALES SLIP OR INVOICE AND RETURN THE BARBEQUES GALORE PRODUCT REGISTRATION CARD IMMEDIATELY.

This limited warranty shall be limited to the repair or replacement of parts which prove defective under normal use and service and which on examination shall indicate to Barbeques Galore's satisfaction they are defective. Before returning any parts to Barbeques Galore, contact our **Customer Service Center** at (800) 752-3085 or email us at customerservice@bbqgalore.com If Barbeques Galore confirms the defect and approves the claim, Barbeques Galore will elect to repair or replace such part without charge. Parts returned to Barbeques Galore must be sent freight prepaid to Barbeques Galore, Inc. Customer service center 10 Orchard Road #200, Lake Forest, CA. 92630 (www.bbqgalore.com) or to the nearest Barbeques Galore Store. Barbeques Galore will return parts to the purchaser freight or postage prepaid.

The LP tank manufacturer is solely responsible for the materials, workmanship and performance of the tank. If the tank has a defect, malfunctions, or you have questions regarding the tank, call the tank manufacturer's customer service center. The phone number is on the warning decal which is permanently attached to the tank. If the tank manufacturer has not resolved the issue to your satisfaction, then call the Barbeques Galore store nearest you.

Model Number _____ Serial Number _____

Date of Purchase _____ Purchase From _____

REFILLING THE PROPANE GAS CYLINDER

ALL NEW CYLINDERS MUST BE PURGED BEFORE THE FIRST FILLING.

IMPORTANT:

This barbecue is intended for use with LP cylinders equipped with a QCC-1 / OPD valve (Quick Connect Coupling Type 1 with Overfill Prevention Device).

WARNING

Purging and filling of LP-Gas cylinders must be performed by personnel who have been thoroughly trained in accepted LP-Gas industry procedures. Failure to follow this instruction may result in explosion, fire, severe personal injury, or death.

1. Turn heat control knobs and Gas Cylinder valve to "OFF" position.
2. Propane cylinder equipped with QCC-1 valve (**Figure 1**) is equipped with a right handed thread. Turn Black plastic nut counter-clockwise to loosen.
3. Remove cylinder from Grill. Have cylinder filled by your local Propane gas dealer.
4. Some Propane Cylinders have a bleed-off valve (**Figure 1**) This bleed-off valve should be inspected for leaks after each refilling of the tank. Turn clockwise to reseal.
5. Fasten full Propane tank to Grill and connect **QCC-1** fitting to tank valve (**Figure 1**) by turning clockwise.
6. With heat control knobs still at "OFF" position, turn on Cylinder valve.

Figure 1

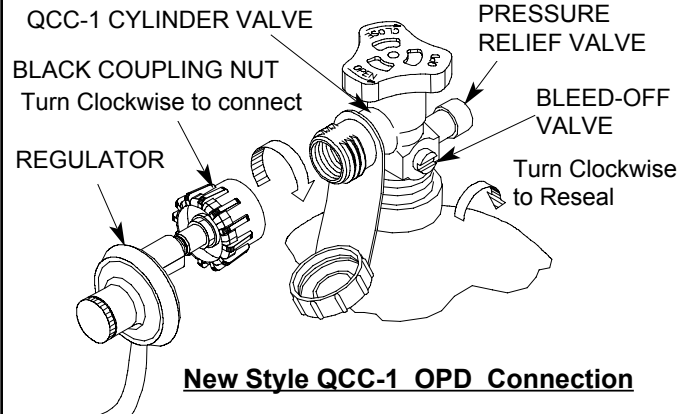

USING SOAP SOLUTION, TEST THE GAS CONNECTION FOR LEAKS. (See Page 2 for information on mixing and applying soap solution.) If bubbles appear, there is a leak; tighten or correct gas connections as necessary. After checking for leaks, turn valve off.

Assembly Instructions

1. Remove unit from carton carefully, ensuring drip tray does not fall out.
2. Check barbecue for damage.
3. Check that proper orifices are installed in the valves.

IMPORTANT: The **Turbo** barbecue is supplied from the factory setup for **Natural Gas** and fitted with **Natural Gas orifices** stamped **1.75** (**Figure 2a**).

Rear burner units are supplied from the factory setup for **Natural Gas** and fitted with **Natural Gas Orifices** (see **Figure 2b**) stamped as follows:

- 3 Burner: 1.68mm (rear burner)**
4 & 5 Burner: 1.80mm (rear burner)

NOTE: Ensure barbecue is connected to a **regulated** gas supply. Failure to use the appropriate gas regulator voids all warranties.

Should it be necessary, your Barbeques Galore Store can convert your barbecue from **Natural Gas** to **Propane**.

Figure 2a

Main Burner



LP Gas:
stamped **1.13**



Natural Gas:
stamped **1.75**

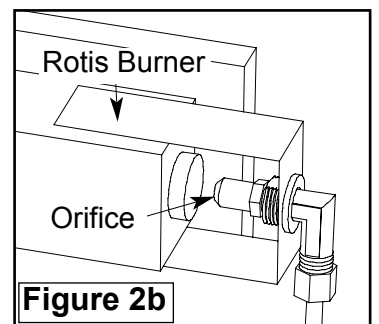

Figure 2b

**Rear Burner on
CG(3,4,5)TDBRN
Models Only**

Important Note: This grill is manufactured to exact specifications. LP models are certified for use with LP gas and NG models are certified for use with Natural Gas. You cannot convert this grill from one fuel type to the other. For your safety, conversion kits are available but can only be installed by a BBQ Galore technician. Any attempt to convert your grill will void your warranty.

Turbo Elite: Stainless Steel Hood Installation

- 4a. Remove the Hood Assembly from the carton carefully. The Top Hinges have been aligned and fastened to the hood section prior to delivery.

Turbo Classic: Aluminum-Sided Hood Installation

- 4b. Remove aluminum-sided hood from carton carefully. Assemble hinge top to hood using stainless steel bolts, fiber washers, stainless washers, lock washers and dome nuts (Figure 3).

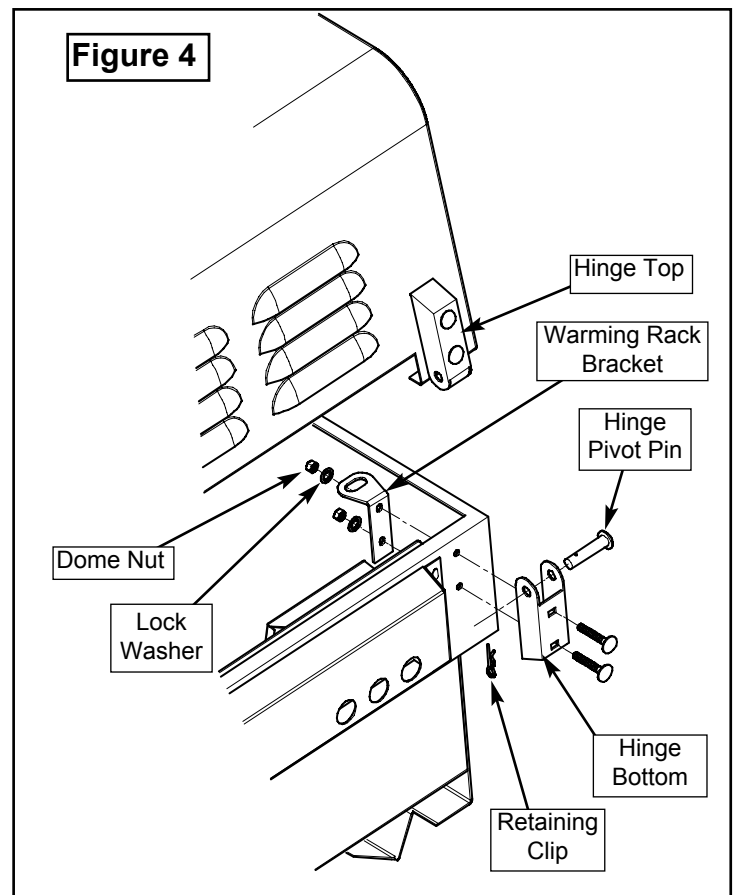
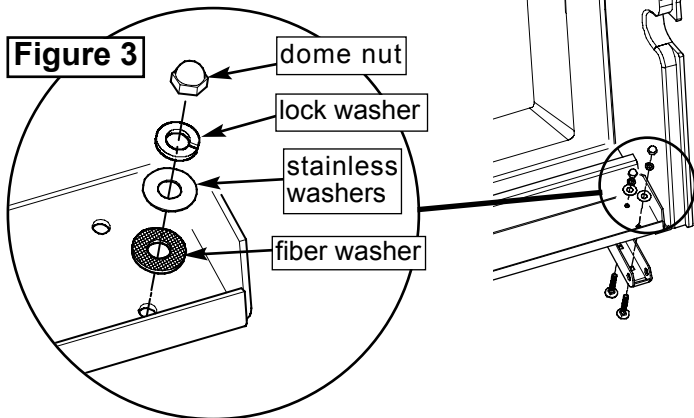

5. Place barbecue on a stable flat surface and fit the Bottom Hinges with Warming Rack Brackets on the inside of the barbecue frame using the bolts, lock washers, and nuts provided (Figure 4).

DO NOT TIGHTEN NUTS AT THIS STAGE. FINGER TIGHT IS SUFFICIENT.

IMPORTANT: IF BARBECUE IS TO BE INSTALLED ON A CART, ASSEMBLE TO CART PRIOR TO ASSEMBLING HOOD TO BBQ FRAME TO MAKE CART ASSEMBLY EASIER.

6. Place the hood section onto the barbecue in the closed position. Align holes on Top and Bottom Hinges and insert Hinge Pivot Pins into position (you may have to move the bottom halves of the hinge assemblies to achieve alignment). Now fit the retaining clips into the hinge pivot pins (Figure 4).
7. Roll the assembled barbecue and hood onto its back edge while holding the hood closed with one hand, tighten the four (4) nuts, securing the hinge and warming rack bracket with the other hand (Figure 5).
8. If your barbecue is equipped with a rear rotisserie burner, the bottom hinges are pre-attached to the rear rotisserie burner mount and there is no need to attach them.

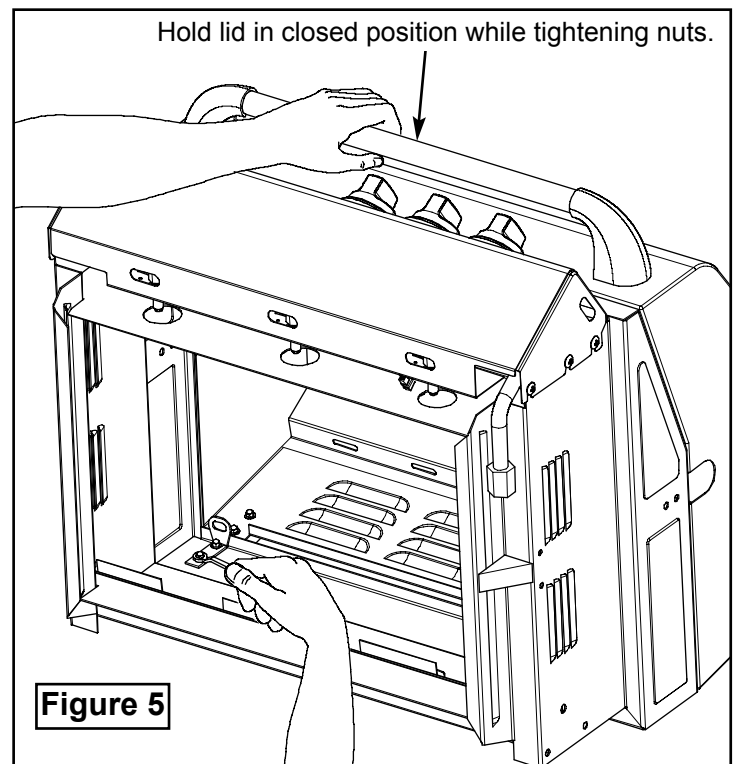

Installing Barbecue Components

9. This Gas Grill must be connected to an appropriate REGULATED gas supply - refer to Safety Information.

10. Install Heat Shields between burners as shown in **Figures 6a & 6b**. There are 2 shields required for the 3 burner barbecue, 3 shields for the 4 burner model and 4 shields for the 5 burner model.

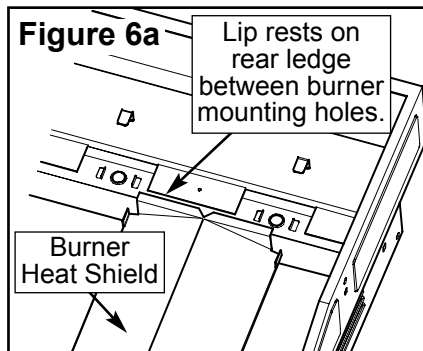

We recommend that you fill the drip tray with *Ultrisorb* approximately 1/4" deep. This will help absorb any grease or residues from the barbecuing process. Change the *Ultrisorb* on a regular basis. A fire may occur if the grease level rises to the top of the *Ultrisorb*. Sand can be used as an alternative to *Ultrisorb*.

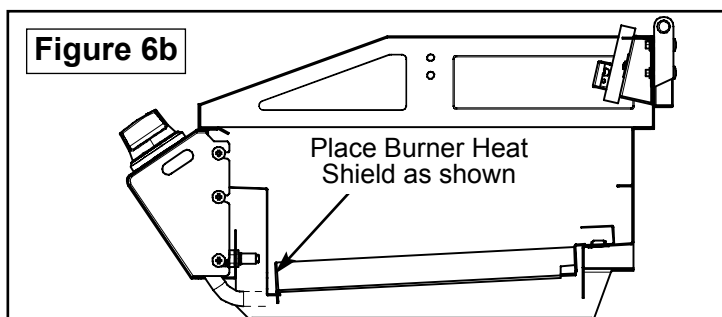

11. Remove the porcelain coated cast iron or Stainless Steel burners (depending on model) from packaging and place into Barbecue. The open end of the burner has to be installed over brass stem of valve and then the rear of the burner is lowered down onto the back bracket locating the cast peg into the appropriate hole (**Figure 7**).

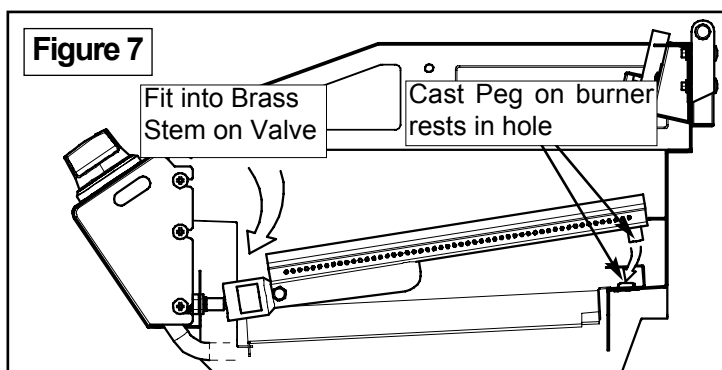

Note: Air Adjustment - The bolt on the side of each burner should be screwed half way in and secured with the locking nut prior to installation.

Figure 8

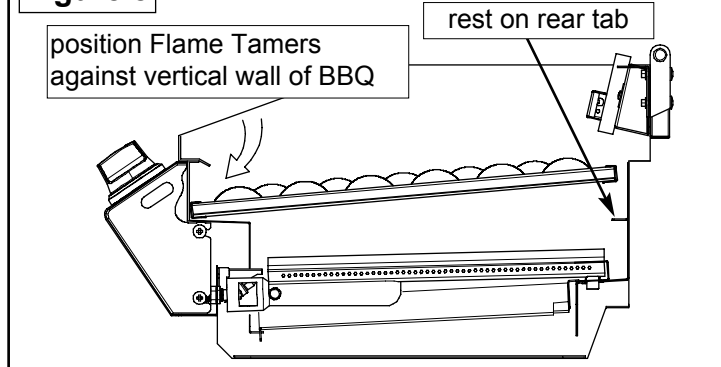

12. Remove the Stainless Flame Tamers from carton and install them into the barbecue above the Burners (**Figure 8**). Place the ceramic briquettes in position as shown in (**Figure 9**). The Flame Tamers must sit level if correctly installed.

Figure 9

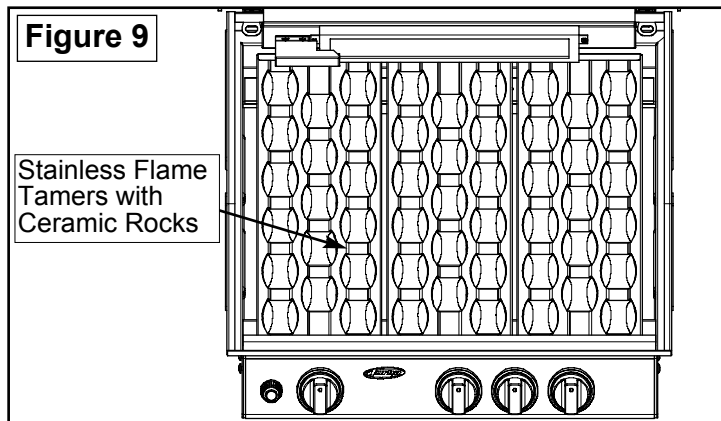

Note: If installing the alternate Lava Rock Grate (Turbo Classic models only), layer the lava rocks evenly - DO NOT PILE (**Figure 10**).

13. Place the Porcelain Cast Iron or Stainless Steel Cooking Grids in place.

Tip: - A light coating of vegetable oil will prevent food from sticking to the grills.

Figure 10

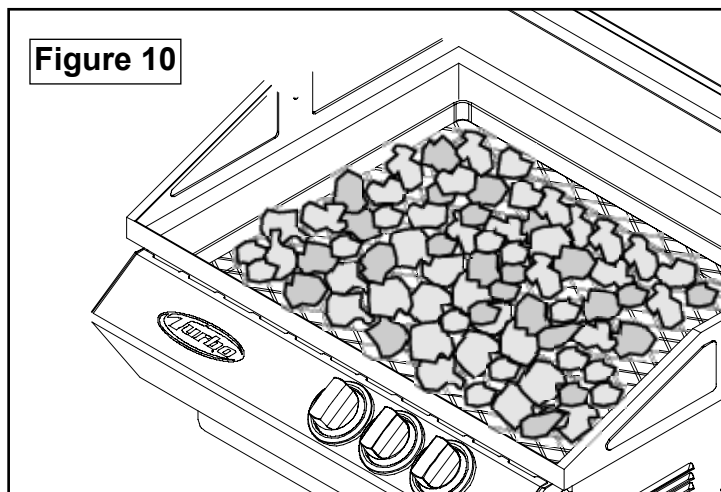

Using Your Gas Grill

Location

THE GAS GRILL IS DESIGNED FOR OUTDOOR INSTALLATION ONLY.

It may be installed on a covered or open patio provided the **sides** and **bottom** are at least **14"** away and the **back** at least **16"** away from **any combustible construction**. The grill must not be located under any overhead unprotected combustible construction.

WARNING

Failure to comply with these instructions could result in a fire or explosion that could cause serious bodily injury, death, or property damage.

Before each use, carefully and thoroughly check regulator hose. If it is evident there is excessive abrasion or wear, or the hose is cut, it must be replaced prior to the appliance being put into operation. Contact your BBQ Galore retailer or by calling BBQ's Galore at (800) 474-5587.

Lighting Instructions

Important: Do not bend directly over grill when lighting the burner. **Lid must be in open position before lighting.**

The gas controls are fitted with a pilot flame ignition system. Push any knob in and turn **slowly** (counterclockwise) to **HIGH** (see Figure 11).

Figure 11

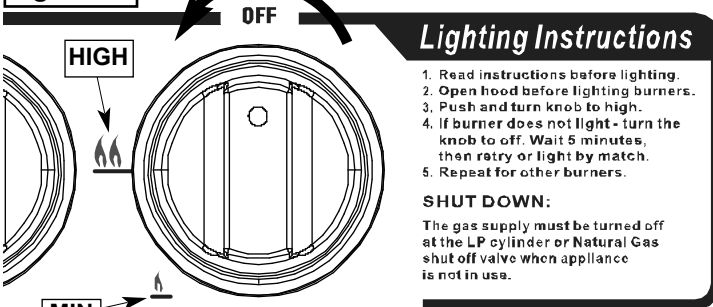

If you have difficulty lighting the burner it may be necessary to turn and hold the knob for 1 (one) second at the point prior to the Ignitor "clicking". If the burner does not light, turn the control knob to OFF, wait 5 minutes for gas to clear, then retry.

If the knob is turned fully counterclockwise the lowest flame setting will occur. To visually check that the burner is operating look between the frame and tray at the flame.

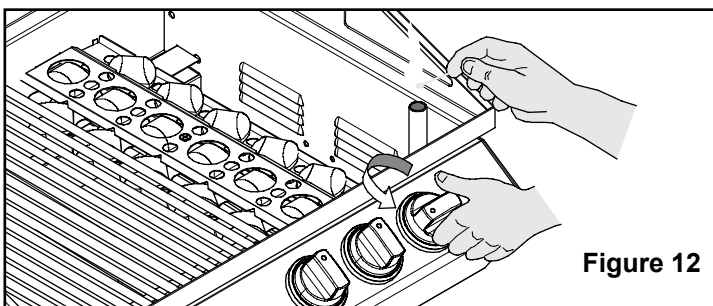

Figure 12

NOTE: If grill does not light with a valve, try an adjacent valve, once ignition is achieved, the other burners will light off the lit burner or the Flash Tube may be used (Figure 12).

Using Your Rotisserie Burner (if equipped):

The Turbo Rotis model is equipped with a rear infrared rotis burner which allows for slow rotis cooking of meats and poultry. Infrared burners radiate heat onto to the outer surface of the food. This allows cooking without the grease drippings burning on the main burner radiants.

Rotisserie Burner Lighting Instructions (Elite Rear Burner Models Only)

Note: The location of the Rotisserie burner makes it more susceptible to winds that will decrease the performance of your rotisserie cooking. For this reason you should not operate the back burner during windy weather conditions.

1. Open the Grill Lid. Failure to do so can result in fire or explosion.
2. Set Rotisserie Burner control knob to OFF and open gas supply.
3. Push down and hold Rotisserie Burner Safety button. Then push and turn Rear Burner Control Knob to high (Figure 13).

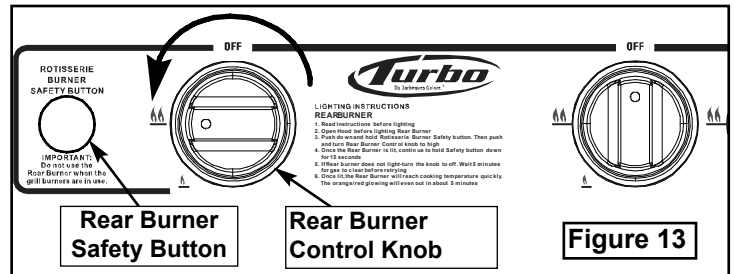

4. Once the Rear Burner is lit, continue to hold Safety button down for 15 seconds.
5. If Rear Burner does not light, turn the knob to off. Wait 15 minutes for gas to clear before re-trying.
6. Once lit, the Rear Burner will reach cooking temperature quickly. The orange/red glowing will even out in about 5 minutes.
7. For best results, always rotisserie cook with the grill lid down and the Rotisserie Burner control knob set to "HIGH". **IMPORTANT: Do not use the Rear Burner when the grill burners are in use.**

Do not attempt to regulate the rotisserie burner by using the control knob. This control has a fixed setting and is not adjustable.

Shutting Your Grill Down

After you have finished using the Gas grill turn all knobs to the OFF position. Close the valve on the gas supply.

Preheating the Grill

Light the burners as previously directed, turn to high and allow the grill to **preheat for 5 minutes maximum**. Lower the lid during this preheating period.

Heat Control

IMPORTANT: When cooking with hood closed, never exceed temperatures of 480°F (250°C).

Direct Cooking: Your Gas grill is equipped with a number of burners which can be regulated easily. This feature gives you the flexibility to cook enough hamburgers to feed the whole gang with all the burners at the same setting, or slow cook a casserole over low heat on one side of the grill while you sear a steak over a high flame on the other side, or just light one or two of the burners for a small meal.

Indirect Cooking: Cook large cuts of meat to golden perfection with indirect heat (Hood must be closed for indirect cooking). By using indirect heat, your food doesn't come in direct contact with flame, instead, the heat from the lighted side of the grill gently circulates throughout the grill (see **Figure 14**).

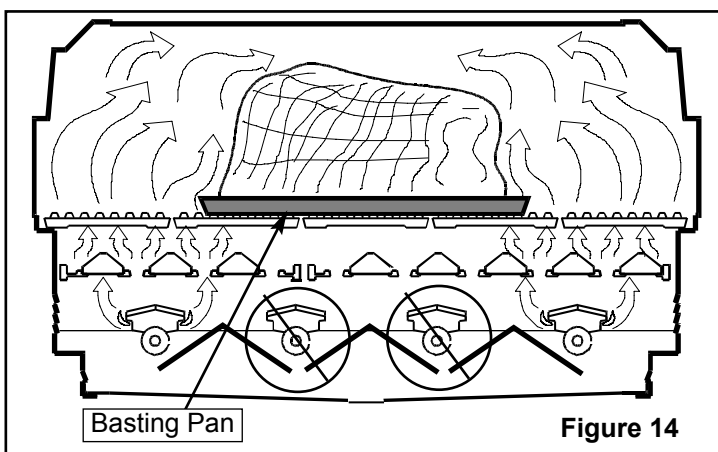

Closed Hood Saves Money

When the smoker hood is closed you have a more constant temperature. Your food will cook faster, with fewer flare-ups, and you will use less energy. Make sure basting pan is in place at all times especially when cooking roasts, whole fish, chickens and ALL rotisserie cooking (see **Figure 18**). Use of a basting pan eliminates manual basting, since the juices drop into the pan, vaporize, rise and self-baste. Water, beer, wine, fruit juices or herbs in the basting pan adds flavor. Gravy or sauce can be made from the drippings. Disposable basting pans prevent flare-ups.

Flare-up Control

Anytime you cook meat above an open flame you will have flare-ups, since flare-ups are caused when the natural juices from the meat fall on the hot Ceramic Rock. Flare-ups, and the resulting smoke, are what give meat cooked over an open flame the delicious outdoor flavor, so expect and encourage some flare-up. However, excessive flare-ups can be caused by cooking extra fatty foods directly on the grill, or by cooking with too high a temperature. These types of flare-ups should be controlled or your food will burn.

To prevent excessive flare-ups, trim off excess fat from meat and poultry before putting it on the grill, or cook particularly fatty meat such as duck, in a basting pan (or put the basting pan on the ceramic rocks directly under the meat). To control excessive flare-ups caused by too high a heat setting, turn the heat control knob to a lower setting.

Optional Rotisserie

The Rotisserie is equipped with a heavy duty motor to turn the solid rotisserie rod. The Warming Rack needs to be removed when using the rotisserie. It also may be necessary to remove Cooking Grills if the rotisserie is used to gain greater depth (see **Figure 18**).

NOTE: When installing Warming Rack, make sure back legs fit into Warming Rack Bracket holes and rest against the back of the barbecue frame (**Figure 15**).

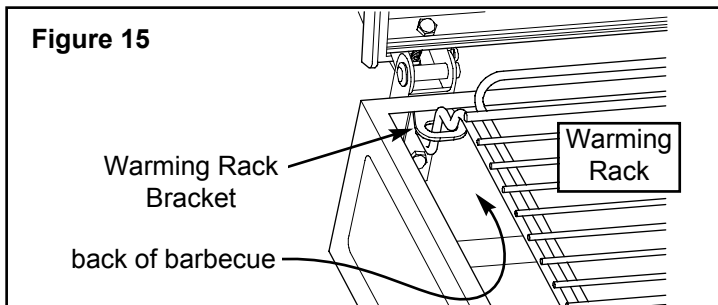

Cleaning Up After Using Your Grill

To keep your grill ready for the next time you want to use it, turn the grill off, then take a long handled soft brass bristle brush and brush off the cooking grills. Be careful, they're hot! Protect your hand from the heat by using an oven mitt to hold the brush.

The **Turbo Classic Barbecue** (**Figure 16**) has been designed and manufactured from heavy gauge porcelain steel for long life, just like an oven. If cleaning is necessary, please use a soft, damp cloth and some mild household detergent. Refer to maintenance instructions.

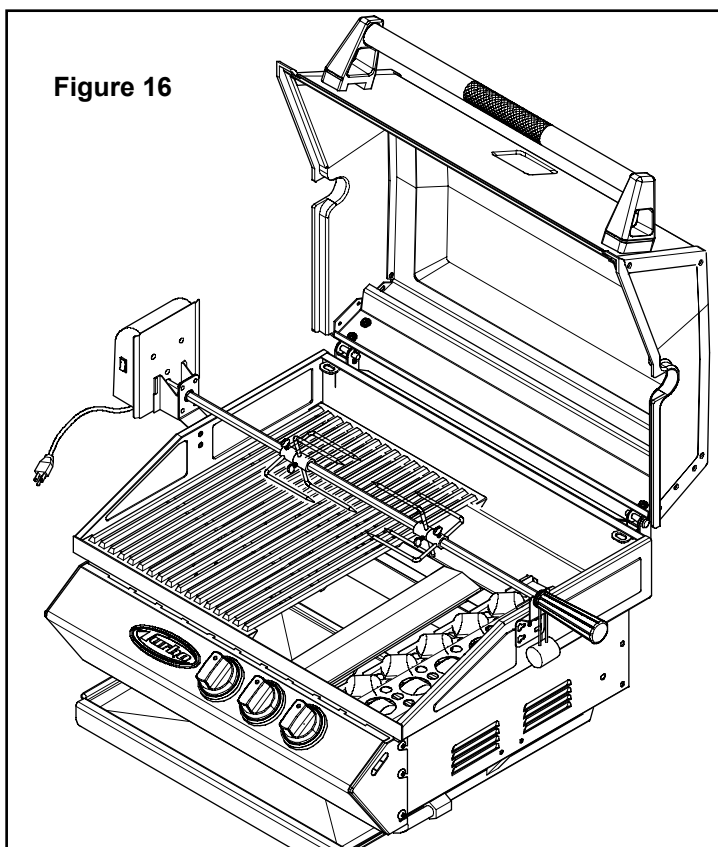

The **Turbo Elite Barbecue (Figure 17)** has been designed and manufactured from heavy gauge porcelain steel for long life. Daily weathering and high heat associated with grill cooking can cause the hood's exterior stainless surfaces to "tan".

Cooking Tips & Care Of Your Gas Grill

Food Preparation

Preparing food to be cooked on your gas grill requires no more effort than if you were preparing it to be cooked on your indoor range. The following tips will help you get the best results right from the start.

1. Trim off excess fat from meat, leaving a thin strip round the edges. To prevent meat from curling up while it cooks, slash the remaining fat at two-inch intervals, taking care not to cut into the meat. Trim off all excess fat from poultry before cooking.
2. Use tongs instead of a fork when turning meat or poultry. The prongs of a fork pierce the meat or poultry, causing it to lose its natural juices.
3. If you use a tomato or sugar base sauce for basting, do not apply until the last five or ten minutes of cooking period. Use over a longer period of time will result in over-browning or charring.
4. Poultry, fish and natural lean meats should be brushed with cooking oil, butter, or margarine several times during the cooking period to avoid their drying out.
5. Meats and poultry should be brought to room temperature before cooking. Frozen foods such as fish and vegetables should be put on the grill without thawing.
6. Salt meat, fish or poultry after cooking, not before or during cooking periods. Other spices including pepper and garlic may be freely applied.

SMOKE COOKING

Smoke cooking is an exceptionally slow method of cooking in which a flavoring source is added to the barbecue in order to impart its own delectable flavor to the meal for a deep smoke flavor.

Soak a flavoring source such as hickory chips, green twigs of apple-wood or wild cherry, garlic cloves or bay leaves in water for 30 minutes prior to use. Loosely wrap in a single layer of aluminum foil, leaving one end slightly open and place on top of the Flame Tamer assembly at the beginning of the cooking period.

For a lighter smoke flavor, add the pre-moistened wrapped flavor source during the last half hour of the cooking period. Remember, smoke cooking is slow cooking. You can't hurry it along without unsatisfactory results. Keep the heat control knobs set at LOW and the lid closed.

Figure 17

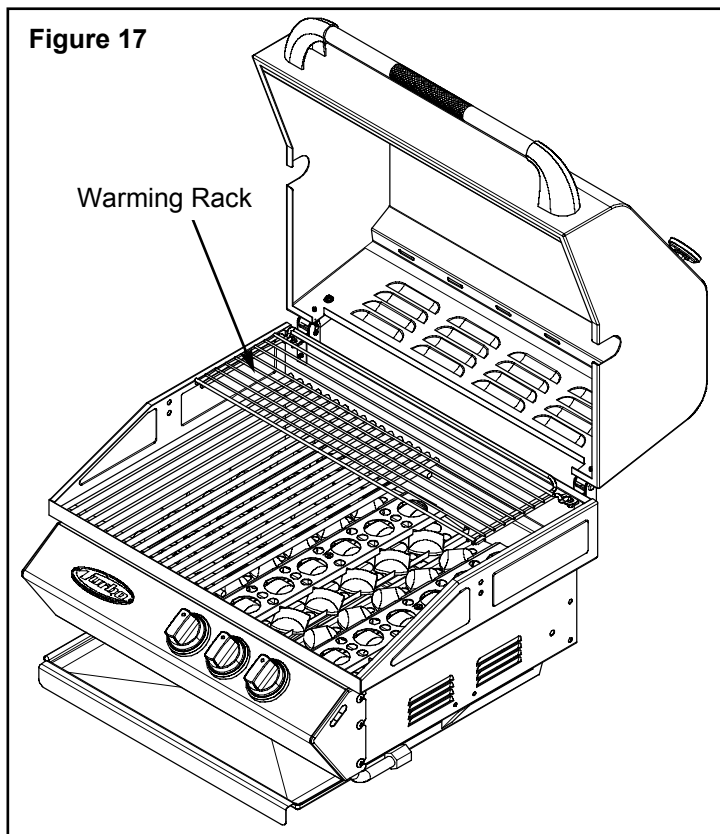

To clean the stainless steel surfaces of your grill, follow these directions;

1. NEVER clean a grill while hot.
2. Shut off gas supply at source and disconnect fuel line from gas valve manifold. Protect fuel line fitting.
3. Remove dirt or grease using a soft cloth, then polish stainless surfaces with a Foam Spray cleaner designed for stainless steel. Never use an abrasive cleaner or scrubber that may scratch your stainless surfaces.
4. Dry with a soft cloth and let air dry before restarting grill.

Note: Warming Rack must be removed for rotisserie cooking. It may be necessary to remove a Cooking Grill to gain greater depth when cooking large cuts of food.

Rotisserie Cooking (non-rear burner models)

A rotisserie is mostly used to cook large pieces of meat and poultry to assure slow, even cooking. The constant turning provides a self-basting action, making food cooked on a rotisserie exceptionally moist and juicy.

Since indirect heat is used in cooking on this type of rotisserie cooking, a foil or aluminum basting pan is advisable to prevent excessive flare-ups. Place the basting pan directly on top of the Flame Tamer. Pan can be emptied with a bulb baster (**Figure 18**).

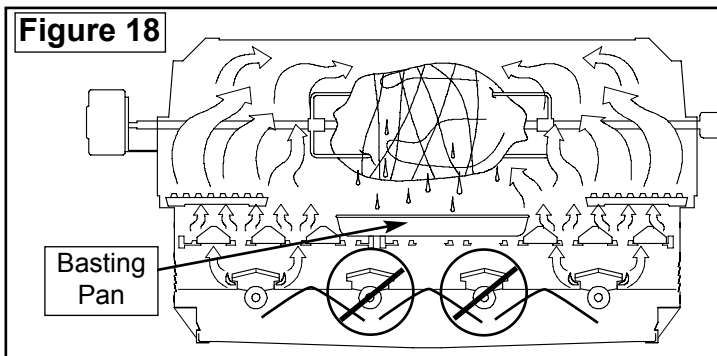

For successful rotisserie cooking, the meat should be centered and balanced as evenly as possible on the spit rod to avoid overworking the rotisserie motor. Center meat on spit, then secure in place with the fork-like skewers. Test the loaded spit for proper balance by supporting both ends in your palms. Roll spit. If spit does not turn easily, the meat is not properly balanced and will need to be repositioned. If your food isn't balanced, use the **Counterbalance** to correct this condition to assure trouble-free rotisserie cooking by always maintaining the perfect balance, see **Page 12**.

Remember, keep lid closed and operate burner on **LOW** when rotisserie cooking.

Rotisserie Cooking (rear burner Elite models)

Rotisserie cooking produces foods that are moist, flavorful and attractive. The optional rotisserie system is most commonly used for cooking meat or poultry and is designed to cook food from the back burner using infrared heat. The location of the burner allows the placement of a cooking pan beneath the food to collect juices for basting and gravy (**Figure 19**).

To flavor the contents of the cooking pan you may add herbs, onions, or other spices of your choice. The back burner is an infrared type, which provides intense searing radiant heat. The intense heat sears in the natural juices and nutrients found in quality cuts of meat.

The cooking times on a rotisserie will be approximately the same as for oven cooking.

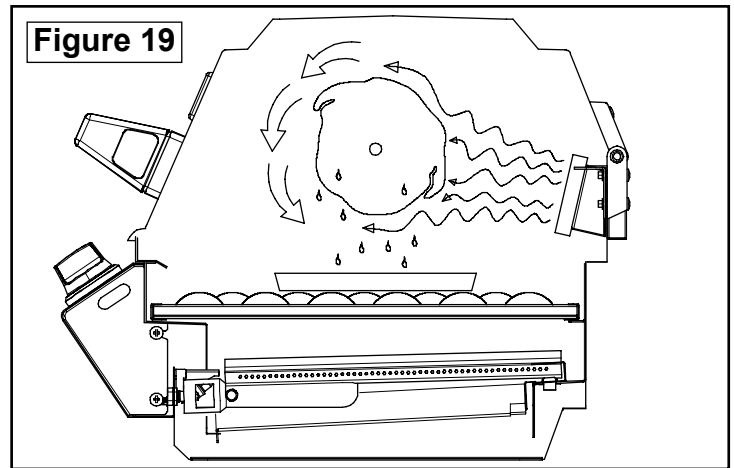

Balancing the Food

In rotisserie cooking, balancing the food is of utmost importance. The rotisserie must turn evenly or the stopping and starting action will cause the food to cook unevenly and possibly burn the heavier side.

The easiest foods to balance are those of uniform shape and texture. To test if the food is balanced correctly when secured, place the ends of the rotisserie spit loosely in the palms of your hands. If there is no tendency to roll, give the spit a quarter turn. If it is still stable, give it a final quarter turn. It should rest without turning in each of these positions. It can then be attached to your grill.

Food Preparation

When preparing poultry, truss the birds tightly so that wings and drumsticks are close to the body of the bird. The cavity of the bird may be stuffed prior to this. Pull the neck skin down and, using a small skewer, fix it to the back of the bird. Push the rotisserie spit through lengthwise, catching the bird in the fork of the wishbone. Center the bird and tighten with the holding forks. Test the balance as described before.

A rolled piece of meat requires the rotisserie skewer to be inserted through the center of the length of meat, then secured and balanced.

For meats that contain bones, it is best to secure the rotisserie skewer diagonally through the meaty sections. If protruding bones or wings brown too quickly, cover with pieces of foil.

Tips for Using The Back Burner

For back burner lighting instructions refer to **page 6** of this Owner's Manual.

The location of the back burner makes it more susceptible to winds that will decrease the performance of your rotisserie cooking. For this reason you should not operate the back burner during windy weather conditions.

For best results, always rotisserie cook with the grill lid down and the Back Burner control knob set to **HIGH**. **Do not use the main grill burners when the Back Burner is in operation.**

Energy Conservation

You'll be pleased to know that by cooking outdoors on your Gas grill you'll be using no more of our nation's precious energy than if you were cooking indoors. And, on hot summer days, cooking outdoors takes the heat out of the kitchen and cuts down on the energy needed to air condition your home.

Maintenance Guide

On at least a monthly basis during times when the BBQ is in use, and at least every other week during high usage periods, the following items must be inspected:

1. Clear the area surrounding the BBQ of ALL combustible materials, gasoline and other flammable vapors and liquids.
2. Ensure that the free flow of combustion and ventilating air is not obstructed.

Porcelain Cooking Grills (Classic Turbo):

The Porcelain Cooking Grills should be cleaned regularly. Use a brass bristle brush to lightly clean off the excess build-up on both sides of the grill. Use care not to scratch or chip the porcelain finish. **Do not use abrasives!**

Stainless Steel Cooking Grills (Elite Turbo):

Use a brass bristle brush to clean off the excess build-up on both sides of the grill.

To thoroughly clean the grills:

1. Lightly brush off excess build-up with brass brush on both sides.
2. Remove grills from BBQ.
3. Wash grills in warm water.
4. With grills still wet, sprinkle baking soda very liberally over surfaces on both sides.
5. Take a wet sponge and vigorously rub and clean off surfaces. *NOTE:* Tough spots may need second application of baking soda and rubbing.
6. Rinse well and dry. Oil lightly.

Porcelain Cast Iron Burners (Classic Turbo):

Burners need to be cleaned periodically. Take each burner out of the BBQ and brush it down very carefully using a brass bristle brush (Use care on Porcelainized Coated Burners - do not damage enamel coating). Make sure every port hole is open. If the holes are obstructed, they may be cleaned using an open paper clip or small drill bit (#31 drill size) on a drill.

Use a fine tooth hacksaw blade or sharp knife to clean out cross over slot on bottom of burner. Tap the open end of burner gently on a hard surface to dislodge any rust, etc. inside.

To visually check that the burner is operating, look at the burner flame between the tray and BBQ frame. The flame should be approximately 1/2"-3/4" long with the high setting (**Figure 20**).

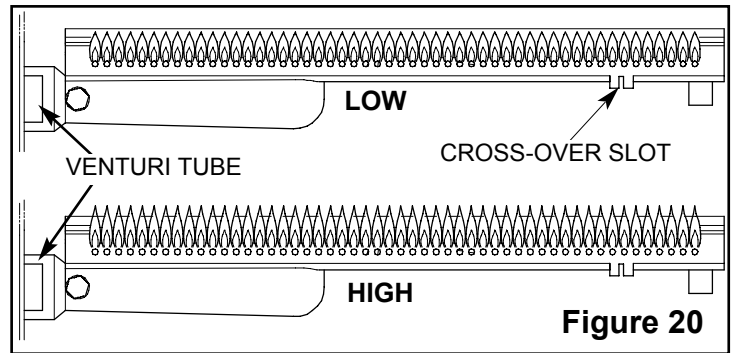

Stainless Burners (Elite Turbo models) should be rotated every 6 months.

⚠ CAUTION: BEWARE OF FLASHBACK

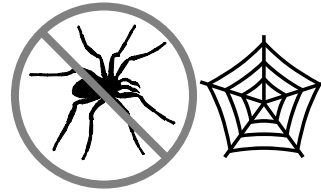

CAUTION: Spiders and small insects occasionally spin webs or make nests in the grill burner tubes during transit and warehousing. These webs can lead to a gas flow obstruction which could result in a fire

in and around the burner tubes. This type of fire is known as a "FLASHBACK" and can cause serious damage to your grill and create an unsafe operating condition for the user.

Although an obstructed burner tube is not the only cause of "FLASHBACK", it is the most common cause. To reduce the chance of "FLASHBACK", you must clean the burner tubes before assembling your grill, and at least once a month in late summer or early fall when spiders are most active. Also perform this burner tube cleaning procedure if your grill has not been used for an extended period of time. A venturi tube cleaner should be used to clean the venturi section (Fig.18).

Porcelain Hood (Classic Turbo models): The Hood should be periodically cleaned as, over time, the material (baked-on grease) inside the Hood will appear to be flaking off. This is residue only and can be cleaned using Simple Green Barbecue Cleaner. The unit has a Porcelain Enamel Finish, exactly like an oven and in extreme cases an oven cleaner can be used, rinse well.

Note: Baking Soda is an ideal cleaner.

Note: Do not use abrasives on any porcelain finish.

Stainless Steel Hood (Elite Turbo models): There are many different stainless steel cleaners available. Always use the mildest cleaning procedure first, scrubbing in the direction of the grain. To touch-up noticeable scratches, sand very lightly with 100 grit sand paper in the direction of the grain. Specks of grease which gather on the surfaces of the grill may give the appearance of rust, these may be removed using a scotch-brite pad in conjunction with a good stainless cleaner. Remember to rub in the direction of the grain.

DO'S & DON'TS

DO..

- ✓ Have propane cylinder (LP units) filled by authorized LP supplier.
- ✓ Record your grill model number on your instructions and keep the instructions and parts list in a convenient place.
- ✓ Check all gas line connections for leaks with soapy solution prior to lighting, tighten until bubbles disappear.
- ✓ Raise the hood before lighting the burner.
- ✓ Preheat the grill 5 minutes maximum before cooking.
- ✓ After cooking, turn the grill off, then take a long handled soft brass bristle brush and brush off the cooking grills. Then turn off gas at the Propane tank or main valve.
- ✓ Use a mitt to turn off tank valve, it can get hot. Cook with hood down when possible. It is generally faster and more efficient. Trapped smoke adds to the flavor.
- ✓ Turn the gas off promptly should you be unable to light the grill immediately. Wait a full 5 minutes before attempting to light grill again.
- ✓ Have proper tools, tongs, mittens and hot pads ready prior to removing foods.
- ✓ Trim excess fats from meats to minimize flare-ups.
- ✓ Let the grill cool before removing any parts for cleaning.
- ✓ Be careful of the control valve setting. LP gas is hotter and the lower setting may be generally preferred.
- ✓ Cover the barbecue when not in use.
- ✓ Use a mitt or glove when opening BBQ lid or turning off Propane tank valve after use.



DON'T..

- ✗ Install grill closer than 14" on the sides or 16" on the back to any combustible construction.
- ✗ Attempt any adjustment of the regulator, it has been preset and tested.
- ✗ Allow the LP tank to lie on its side. Keep in an upright position.
- ✗ Turn a control knob on until a lighted match is inserted in the lighting hole.
- ✗ Use plastics or untempered glass utensils on the grill.
- ✗ Attempt to move an aluminum foil pan while it is hot. Let it cool first before moving it.
- ✗ Cover or block any air openings in the bottom of the grill with foil.
- ✗ Wear long, loose flowing clothing around the grill. Long flowing hair is also easily ignited especially by unexpected flare-ups. Tie hair back or wear a hat or a scarf.
- ✗ Put food on the grill and leave it unattended or unwatched for long periods. Most fats can catch fire even on the lower setting.
- ✗ Use caustic materials, i.e., lye, to clean grill parts.
- ✗ Store any additional Propane gas tanks under barbecue
- ⚠ Wooden Carts not intended for commercial use.
- ⚠ When cooking with hood closed NEVER exceed temperatures of 480°F (250°C).

Wood Chips In A Gas Grill

Wood chips should be soaked for a minimum of 30 minutes. Presoaked chips or chunks may be thrown directly onto a charcoal fire, but they must be in a container or wrapped in foil, log fashion, for use in gas grills.

If smoking is expected to last for a long period of time, you should keep chips soaking in the event you need to throw more on the fire or to add to the container or make another foil log.

INFORMATION REGARDING REPLACEMENT PARTS

Replacement parts for this barbecue unit are available from your Barbeques Galore retailer or if you have any questions call your friends at Barbeques Galore: (800) 752-3085 or email customersevice@bbqgalore.com.

**Stainless Steel Turbo Rotisserie
Assembly Instructions**

26" - SKU# 287904
31" - SKU# 287912
39" - SKU# 287920

Figure 21

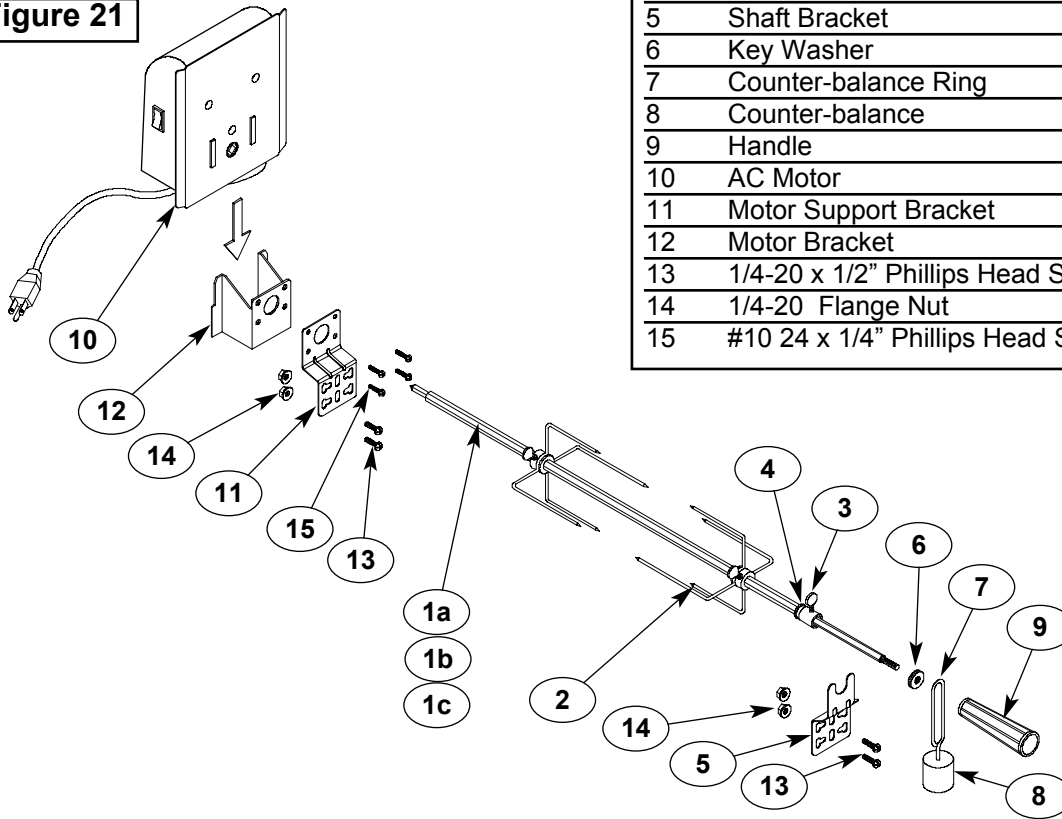

Turbo Rotisserie Parts List			
Item	Description	Part#	Qty
1a	Spit Rod 3 Burner	P05508065A	1
1b	Spit Rod 4 Burner	P05508066A	1
1c	Spit Rod 5 Burner	P05508067A	1
2	Holding Fork	P05508077A	2
3	Thumbscrew 1/4" X 1/2"	S196G04081	3
4	Shaft Collar	P05508061A	1
5	Shaft Bracket	P03308003C	1
6	Key Washer	P05508064A	1
7	Counter-balance Ring	P05508062A	1
8	Counter-balance	P05508063A	1
9	Handle	P05508068E	1
10	AC Motor	P07101016B	1
11	Motor Support Bracket	P03308004C	1
12	Motor Bracket	P03308005C	1
13	1/4-20 x 1/2" Phillips Head Screw	S112G04081	4
14	1/4-20 Flange Nut	S	4
15	#10 24 x 1/4" Phillips Head Screw	S223G03041	4

IMPORTANT SAFEGUARDS:

When using electrical appliances, basic safety precautions should always be followed, including the following:

- 1. READ ALL INSTRUCTIONS BEFORE INITIAL USE!**
- 2.** Always attach the assembled Rotisserie to your grill first, then plug the Cord into an outlet. To disconnect, turn the Rotisserie "OFF" then remove the Plug from outlet.
- 3.** Most grill surfaces and Rotisserie parts are hot during and after cooking, so use reasonable care around your grill and wear protective mitts. Only maneuver the Rotisserie by its handle.
- 4.** To protect against electrical shock, do not immerse Electrical Cord, Plug or Motor in water or expose to rain. Protect electrical cord from burners, hot grill surfaces and grease
- 5.** Do not operate Rotisserie if the cord or plug becomes damaged, or if the Rotisserie malfunctions or has been damaged in any manner.
- 6.** Do not let children operate your grill or Rotisserie, and do not let children play nearby.
- 7.** Unplug the Rotisserie from electrical outlet when not in use and before cleaning. Allow to cool before adding or removing parts. When Rotisserie is not in use, store indoors in a dry place.
- 8.** The use of accessory attachments is not recommended by the manufacturer and may cause injuries. Do not use this Rotisserie for other than its' intended use.
- 9.** When Rotisserie cooking, place a Cooking Pan under the food to be cooked. This will capture the drippings and keep your grill clean from excess grease which could cause a fire. Use caution when moving a Cooking Pan containing hot oils.
- 10.** Should a grease fire occur, turn the burners and gas off and leave the grill CLOSED until the fire is out.
- 11.** The Rotisserie Motor is set for 110/120V, 60Hz AC current.
- 12.** This Rotisserie is for outdoor use only.

Rotisserie Assembly Instructions

1. Assemble Motor Support Bracket (11) and Motor Bracket (12) using four screws (15) as shown in Figure 22.
2. Attach Motor Bracket Assembly to side of barbecue frame (can be mounted on either the left or right side of the frame) using two screws (13), and two nuts (14) (Figure 23).
3. Attach Shaft Support Bracket (5) to opposite side and secure with two screws (13), and two nuts (14) (Figure 24).
4. Insert Rotisserie Motor (10) onto Motor Bracket Assembly (Figure 21).
5. Assemble Key Washer (6), Counter-balance (7,8), and Handle (9) to Spit Rod (1)..Slide Shaft Collar (4) with long end towards handle as shown in Figure 24.
6. Slide Holding Forks (2) onto Spit Rod (1). Place food onto Spit and secure with Holding Forks. Secure with Thumbscrews (3). Place Spit assembly over Shaft Bracket (5) and position into Motor. Secure position with Thumbscrew (3).

NOTE: Close Hood carefully and align the Motor (10) and Motor Bracket (12) so that the Rotisserie Spit is centered in the Lid openings allowing 1/16" clearance to allow Spit to turn (see Figure 25).

7. Ensure that all Bolts are tightened securely.

NOTE: Cooking Grates and Warming Rack are removed from Barbecue for all Rotisserie Cooking. (Drip Trays are recommended for use in all Rotisserie Cooking).

Figure 22

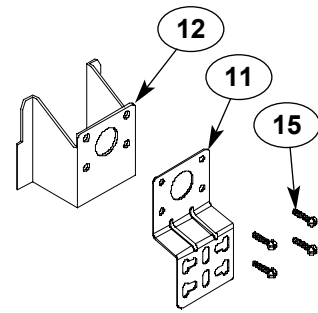

Figure 23

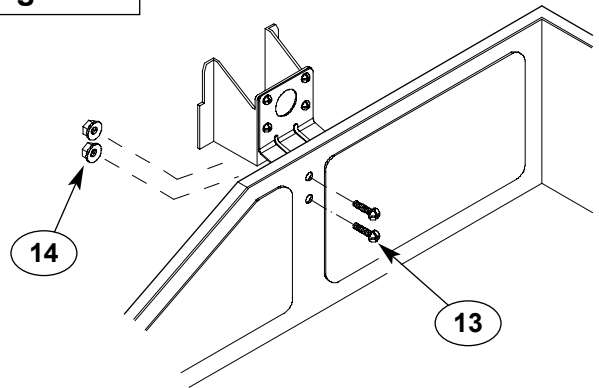

Figure 24

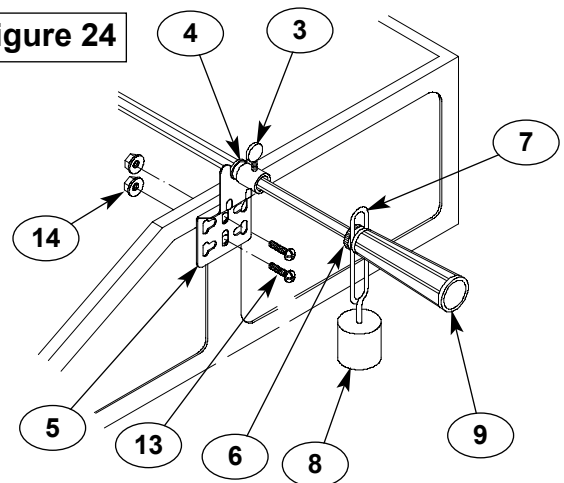
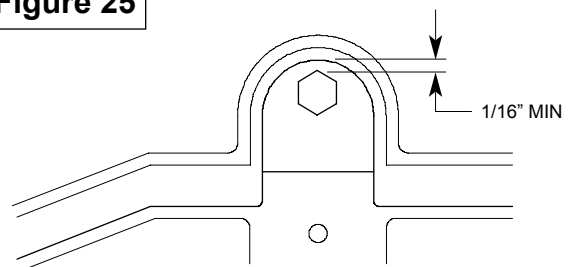
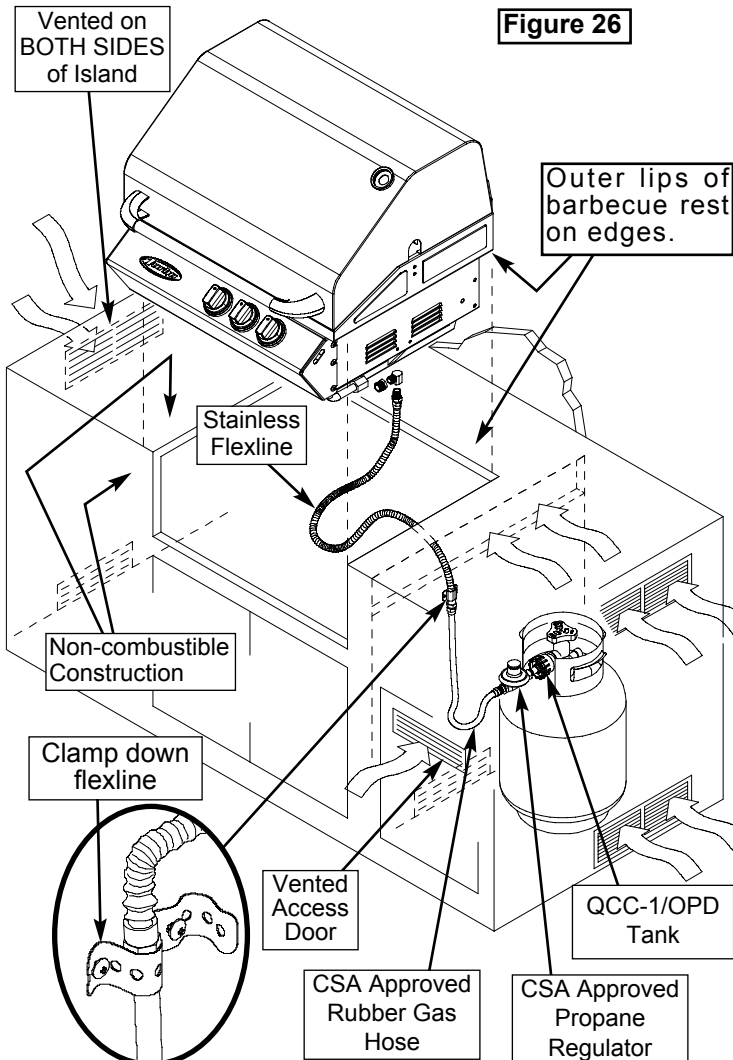

Figure 25



Outdoor Propane BBQ Built-in Installation Specifications

WARNING: When using Propane, **EXTREME CAUTION** should be used to provide ample ventilation of vapor from the enclosure. LP Gas vapor is heavier than air and **SERIOUS INJURY** from a **DANGEROUS EXPLOSION** could occur if LP Gas is allowed to accumulate in an enclosure and then ignited. Both the Barbecue enclosure and LP cylinder enclosure require venting that must be provided at the floor level of the enclosure to allow any leaking LP Gas vapor to escape.



NOTE: When installing a barbecue equipped for liquid propane in an island, the propane tank must be in a separate enclosure that is completely isolated from the barbecue. It must be cross-ventilated in accordance with the current standard. The propane tank **MUST NEVER** be installed directly under the barbecue.

NOTE: Upper & lower ground-level vents (20 sq. in. minimum each) **MUST BE PROVIDED** for combustion air on both sides of built-in construction. Please ask a Barbeques Galore associate for full details.

Barbecues must be installed in accordance with CSA specifications and all local building codes.

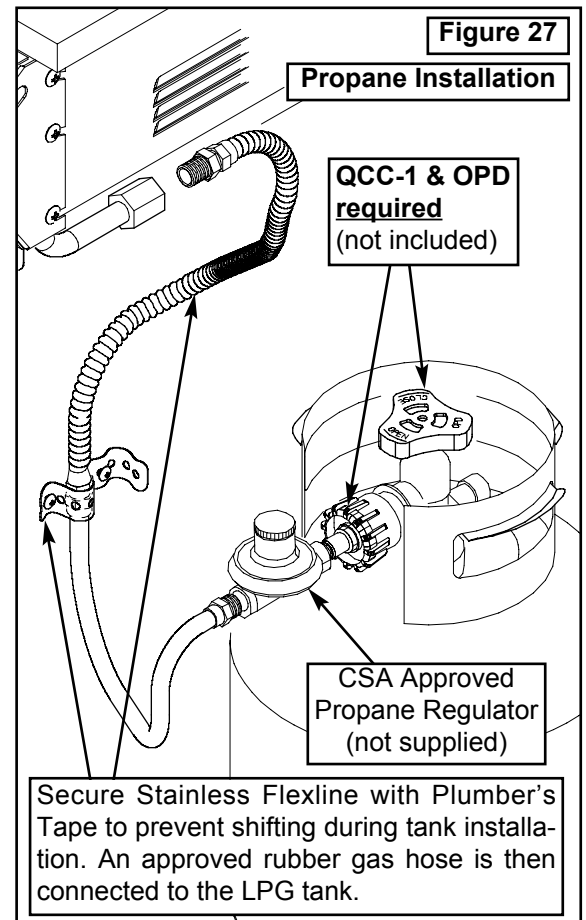

⚠ WARNING

Failure to comply with these instructions may result in a fire or explosion that could cause property damage, serious bodily injury or death. This gas grill is intended for outdoor use only and is **not** intended to be installed in or on recreational vehicles or boats.

⚠ WARNING Vapors from products containing Chlorine and other caustic chemicals can cause Stainless Steel flexible connectors to corrode. THESE PRODUCTS SHOULD NOT BE STORED IN AN ISLAND OR NEAR THE connector. Cleaning solutions, Household Chemicals and Solder fluxes can also cause pinholes if they come in contact with these connectors and **MUST** be washed off immediately with water.

NOTE: When choosing a location for your Gas grill, keep in mind that it should not be located under any overhead combustible construction. The side and bottom of the grill should not be any closer than 14 inches to combustible construction, and the back of the grill should not be any closer than 16 inches to combustible construction.

Barbecues must be installed in accordance with CSA specifications and all local building codes.

Questions? Call our Grill Information Center: 1-800-752-3085 Monday thru Friday 8am-4:30pm PST

Outdoor Natural Gas BBQ Built-in Installation Specifications

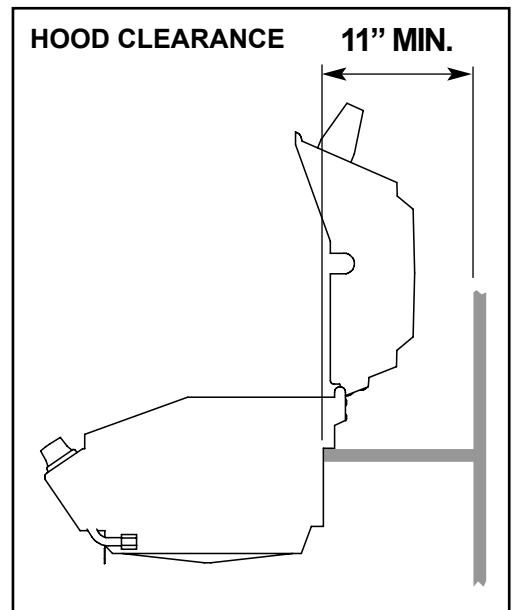
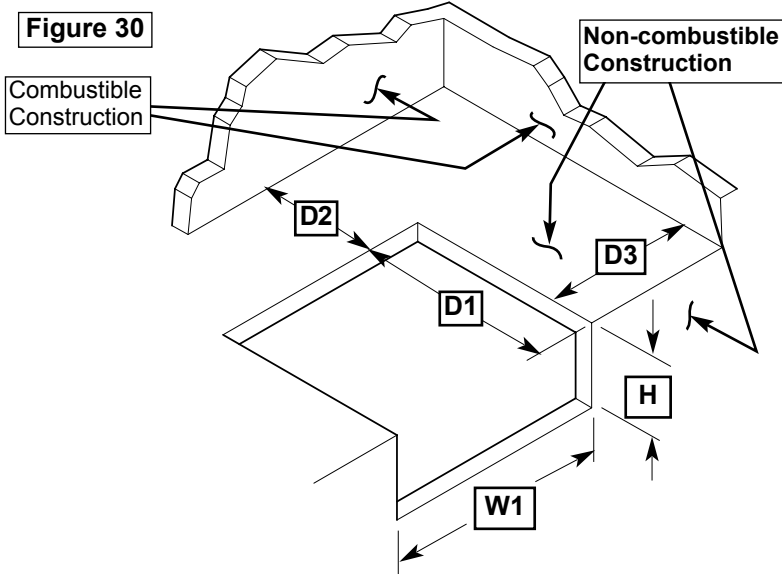
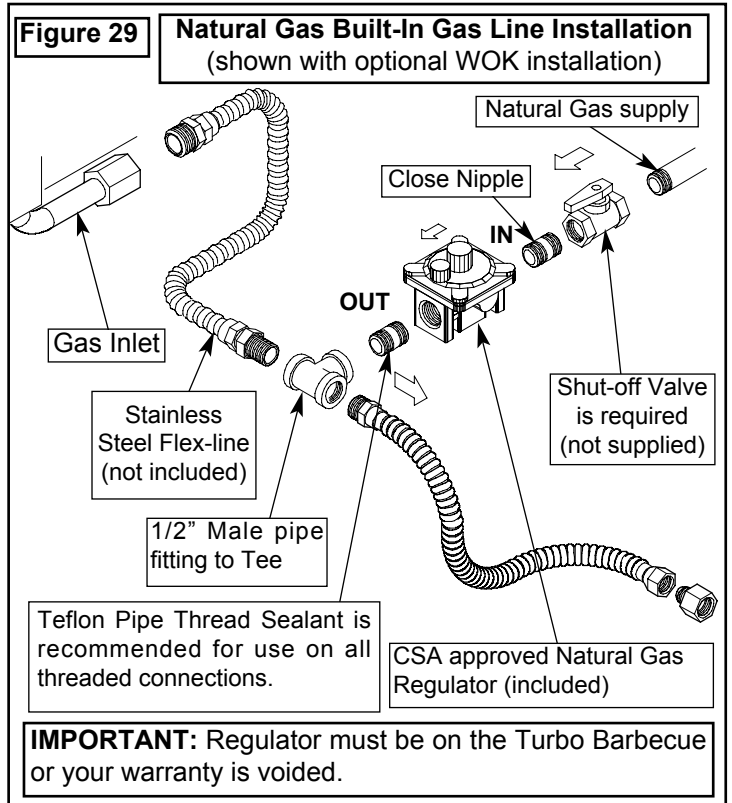
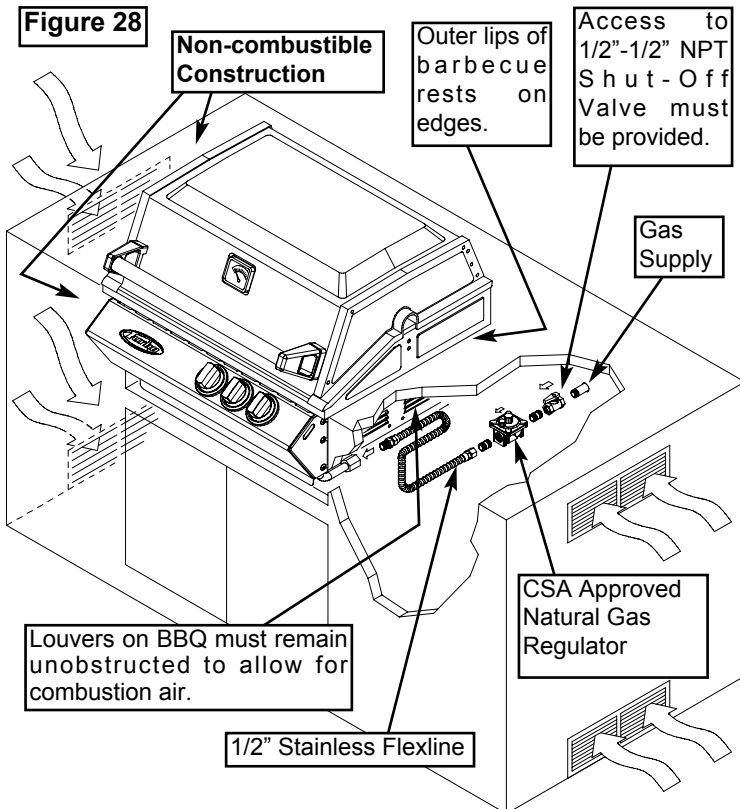

BUILT-IN CUTOUT DIMENSIONS TO NON-COMBUSTIBLE CONSTRUCTION					
MODEL	W1	D1	D2	D3	H
CG3TCBN (Classic)	24-1/2"	19-3/4"	16"	14"	9-1/2"
CG3TDBRN (Elite)	24-1/2"	19-3/4"	16"	14"	9-1/2"
CG4TCBN (Classic)	30-1/2"	19-3/4"	16"	14"	9-1/2"
CG4TDBRN (Elite)	30-1/2"	19-3/4"	16"	14"	9-1/2"
CG5TCBN (Classic)	38-1/2"	19-3/4"	16"	14"	9-1/2"
CG5TDBRN (Elite)	38-1/2"	19-3/4"	16"	14"	9-1/2"
Turbo Classic WOK	12"	19"	16"	14"	9"

Figure 31

Turbo Classic
Models: XG(3/4/5)TCN

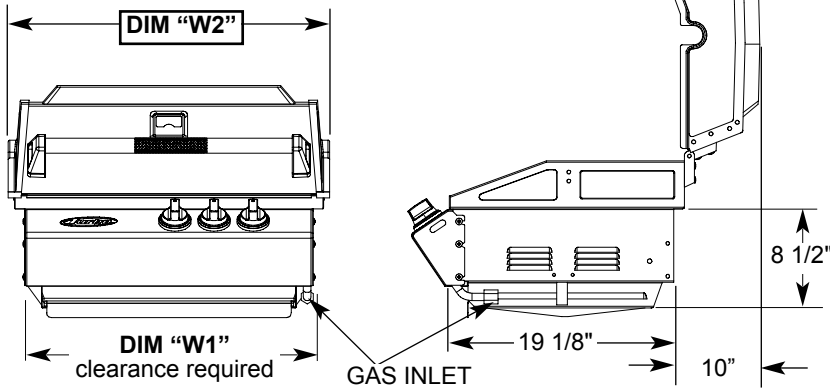

Figure 32

Turbo Classic Built-in WOK

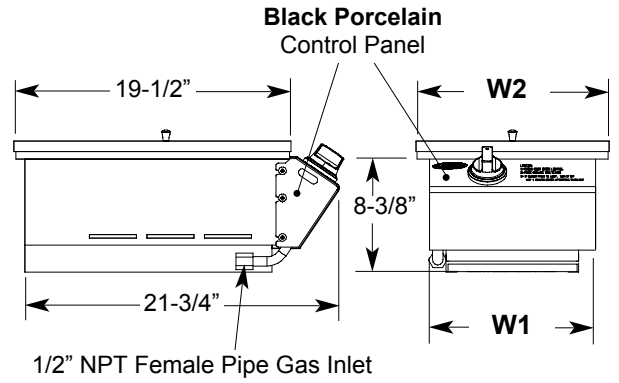

Figure 33

Turbo Elite
Models: XG(3/4/5)TDN

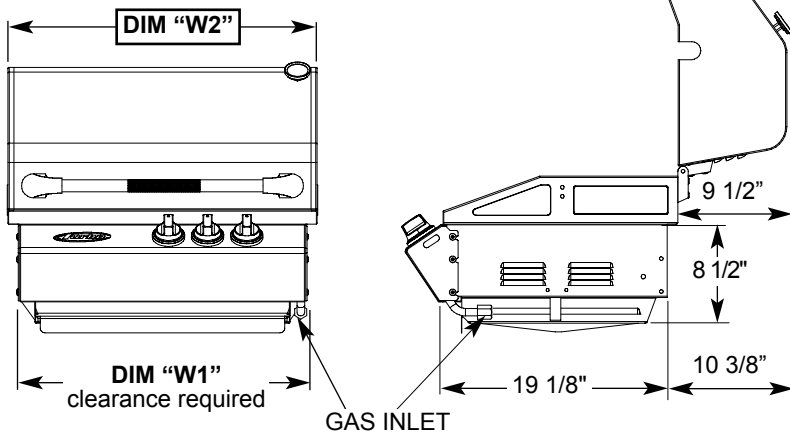
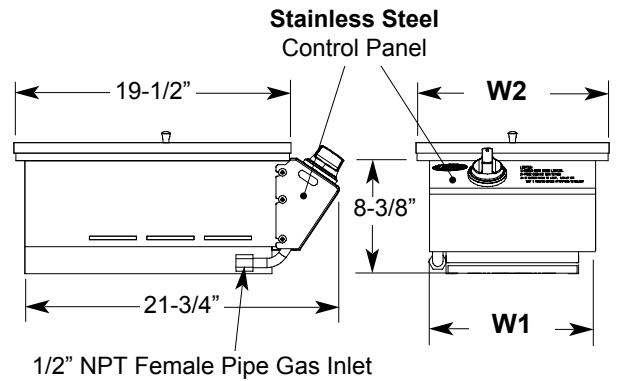

Figure 34

Turbo Elite Built-in Wok



MODEL	W1	W2
CG3TCN	24-1/2"	25-5/8"
CG3TCBRN	24-1/2"	25-5/8"
CG3TDN	24-1/2"	25-3/4"
CG3TDBRN	24-1/2"	25-3/4"
CG4TCN	30-1/2"	31-5/8"
CG4TCBRN	30-1/2"	31-5/8"
CG4TDN	30-1/2"	31-3/4"
CG4TDBRN	30-1/2"	31-3/4"
CG5TCN	38-1/2"	39-3/8"
CG5TCBRN	38-1/2"	39-3/8"
CG5TDN	38-1/2"	39-1/2"
CG5TDBRN	38-1/2"	39-1/2"
Classic & Elite WOK	11-3/4"	13-1/4"

ITEM	QTY						SKU#	Description
	CG3TCBN	CG3TDBRN	CG4TCBN	CG4TDBRN	CG5TCBN	CG5TDBRN		
1	1						161410	G Frame - 3 Burner Black
			1				161425	G Frame - 4 Burner Black
					1		161430	G Frame - 5 Burner Black
		1					293548	G Frame - 3 Burner Black - Rear Burner
				1			293555	G Frame - 4 Burner Black - Rear Burner
						1	293563	G Frame - 5 Burner Black - Rear Burner
2	1	1	1	1	1	1	100743	Baffle for Turbo Control Panel
3	1						293571	Control Panel - 3 Burner Black Turbo Classic
			1				293589	Control Panel - 4 Burner Black Turbo Classic
					1		293597	Control Panel - 5 Burner Black Turbo Classic
4		1					297036	3 Bnr Elite RB Ctrl Panel#2
				1			297044	4 Bnr Elite RB Ctrl Panel#2
						1	297051	5 Bnr Elite RB Ctrl Panel#2
5	3		4		5		260158	Control Knob Large Black -Turbo Classic
6		3		4		5	269597	Control Knob Large Plated -Turbo Elite
7	1	1					266619	Drip Tray S/S 26" - No Holes
			1	1			266627	Drip Tray S/S 31" - No Holes
					1	1	266635	Drip Tray S/S 39" - No Holes
8	3	3	4	4	5	5	269605	Flame Thrower Bracket w/Electrode
9	1						269662	Manifold Assembly 3 Burner Turbo NG
			1				269670	Manifold Assembly 4 Burner Turbo NG
					1		269688	Manifold Assembly 5 Burner Turbo NG
		1					293639	Manifold Assembly 3 Burner Turbo NG-R/Bnr
				1			293647	Manifold Assembly 4 Burner Turbo NG-R/Bnr
						1	293654	Manifold Assembly 5 Burner Turbo NG-R/Bnr
10	1	1	1	1	1	1	269696	Manifold Tube,Turbo,#1NG
	1	1	1	1	1	1	269704	Manifold Tube,Turbo,#2NG
	1	1	1	1	1	1	269712	Manifold Tube,Turbo,#3NG
			1	1	1	1	269720	Manifold Tube,Turbo,#4NG
					1	1	269738	Manifold Tube,Turbo,#5NG
11	1	1	1	1	1	1	269613	Flame Thrower Tube, Turbo, 150mm
	1	1	1	1	1	1	269621	Flame Thrower Tube, Turbo, 210mm
	1	1	1	1	1	1	269639	Flame Thrower Tube, Turbo, 310mm
			1	1	1	1	269647	Flame Thrower Tube, Turbo, 410mm
					1	1	269654	Flame Thrower Tube, Turbo, 510mm
12	3	3	4	4	5	5	154179	Orifice Holder with Nut
13	3	3	4	4	5	5	242321	Orifice - Natural Gas
							242305	Orifice - Propane Gas
14	2	2	2	2	2	2	161450	Hinge Top
15	2	2	2	2	2	2	161465	Hinge Bottom
16	2	2	2	2	2	2	161470	Warming Rack Bracket
17	2	2	2	2	2	2	161584	Hinge Pivot Pin (Style 3)
18	2	2	2	2	2	2	161599	Retaining Clip (Style 3)
19	8	8	8	8	8	8	183434	S/Steel Bolts for S/Steel Hinge
20	4		4		4		161876	Stainless Steel Flat Washer
21	8	8	8	8	8	8	161881	Lock Washer #10 - Zinc
22	8	8	8	8	8	8	196063	Dome Nut
23	3	3	4	4	5	5	293696	S/S Flame Tamer (New) W/Ceramics
24	1						112306	Rock Grate - 3 Burner (Alternate)
			1				112311	Rock Grate - 4 Burner (Alternate)
					1		112326	Rock Grate - 5 Burner (Alternate)
25	2		2		3		124840	Lava Rock (Alternate)
26		1				1	259895	3 Bnr Stainless Burner Pack
				2		1	259887	2 Bnr Stainless Burner Pack
27	1				1		186676	3 Bnr Porcelain C I Burner Pack
			2		1		255521	2 Bnr Porcelain C I Burner Pack
28		2					210161	Cooking Grill 13" Stainless Steel
				4		5	210153	Cooking Grill 8" Stainless Steel
29	2						291906	Cooking Grill 13" (W style) M/Enml.
			4		5		291914	Cooking Grill 8" (W style) M/Enml.
30		1					249284	Stainless Hood 3 Burner - Turbo Elite
				1			246090	Stainless Hood 4 Burner - Turbo Elite
						1	269761	Stainless Hood 5 Burner - Turbo Elite

ITEM	QTY						SKU#	Description
	CG3TCBN	CG3TDBRN	CG4TCBN	CG4TDBRN	CG5TCBN	CG5TDBRN		
31	1		1		1		161485	Side Panel - Left (Style 3)
32	1		1		1		161490	Side Panel - Right (Style 3)
33	1						161504	Back Panel - 3 Burner (Style 3)
			1				161519	Back Panel - 4 Burner (Style 3)
					1		161524	Back Panel - 5 Burner (Style 3)
34	1						253161	Shroud Black w/Compts - 3 Burner
			1				253179	Shroud Black w/Compts - 4 Burner
					1		266189	Shroud Black w/Compts - 5 Burner
35	1		1		1		161579	Hood Hardware Pack Assy (Style 3)
36	1						254011	26" S/Steel Handle
			1				254029	31" S/Steel Handle
					1		254037	39" S/Steel Handle
37	1	1	1	1	1	1	156733	Turbo Badge
38		1		1		1	218347	Hood Thermometer - Turbo Elite
39	1		1		1		120776	Hood Thermometer - Turbo Classic
40	1	1	1	1	1	1	161603	Crossfire-Stainless Steel 3 Burner
	1	1	1	1	1	1	161618	Crossfire-Stainless Steel 4 Burner
	1	1	1	1	1	1	161623	Crossfire-Stainless Steel 5 Burner
41	2	2	2	2	2	2	163133	Clip for Crossfire
42	1	1	1	1	1	1	163207	Lighting Instruction Decal
43	2	2	2	2	2	2	162772	Hood Buffer
44	1						171330	26" Warming Rack - Porcelain Enamel
			1				172197	31" Warming Rack - Porcelain Enamel
					1		196071	39" Warming Rack - Porcelain Enamel
45		1					269787	26" Warming Rack - Stainless Steel
				1			269795	31" Warming Rack - Stainless Steel
						1	269803	39" Warming Rack - Stainless Steel
46		2		2		2	269811	Handle Brackets for S/Steel Hood
47		1					269829	Handle 3 Bnr S/Steel Hood
				1			269837	Handle 4 Bnr S/Steel Hood
						1	269845	Handle 5 Bnr S/Steel Hood
48	3	3	4	4	5	5	269928	Valve- Turbo Flame Thrower
49	1		1		1		244061	Black Handle Bracket Assembly
50	2	2	3	3	4	4	287326	Heat Shield S/Steel
51		1					297150	Rear Burner Small - Black
				1		1	297168	Rear Burner Large - Black
			1				297176	Rear Burner Surround-3Bnr - black
52				1			297184	Rear Burner Surround-4Bnr - black
						1	297192	Rear Burner Surround-5Bnr - black
			1				297127	Rear Burner Cover-3 Bnr - black
53				1			297135	Rear Burner Cover-4 Bnr - black
						1	297143	Rear Burner Cover-5 bnr - black
54		1		1		1	297200	Rear Burner Valve
55		1		1		1	297119	Rear Burner Collector Box - black
56		1		1		1	293803	Rear Burner S/S Flexline
57		1		1		1	297069	Safety Thermocouple Tube
58		1		1		1	297101	Safety Button Nut
59		1		1		1	297010	Safety Valve Rear Burner
60		1		1		1	297036	Gas Supply Tube - Safety Valve
61							295808	Rear Trim f/Turbo 3B w/RB
				1			295816	Rear Trim f/Turbo 4B w/RB
						1	297226	Rear Trim f/Turbo 5B w/RB
62			1	1			297077	3 & 4 R/Bnr F/Thrower Gas Line
						1	297085	5 R/Bnr F/Thrower Gas Line
63	1	1	1	1	1	1	297093	Lighting Tube

Turbo Classic

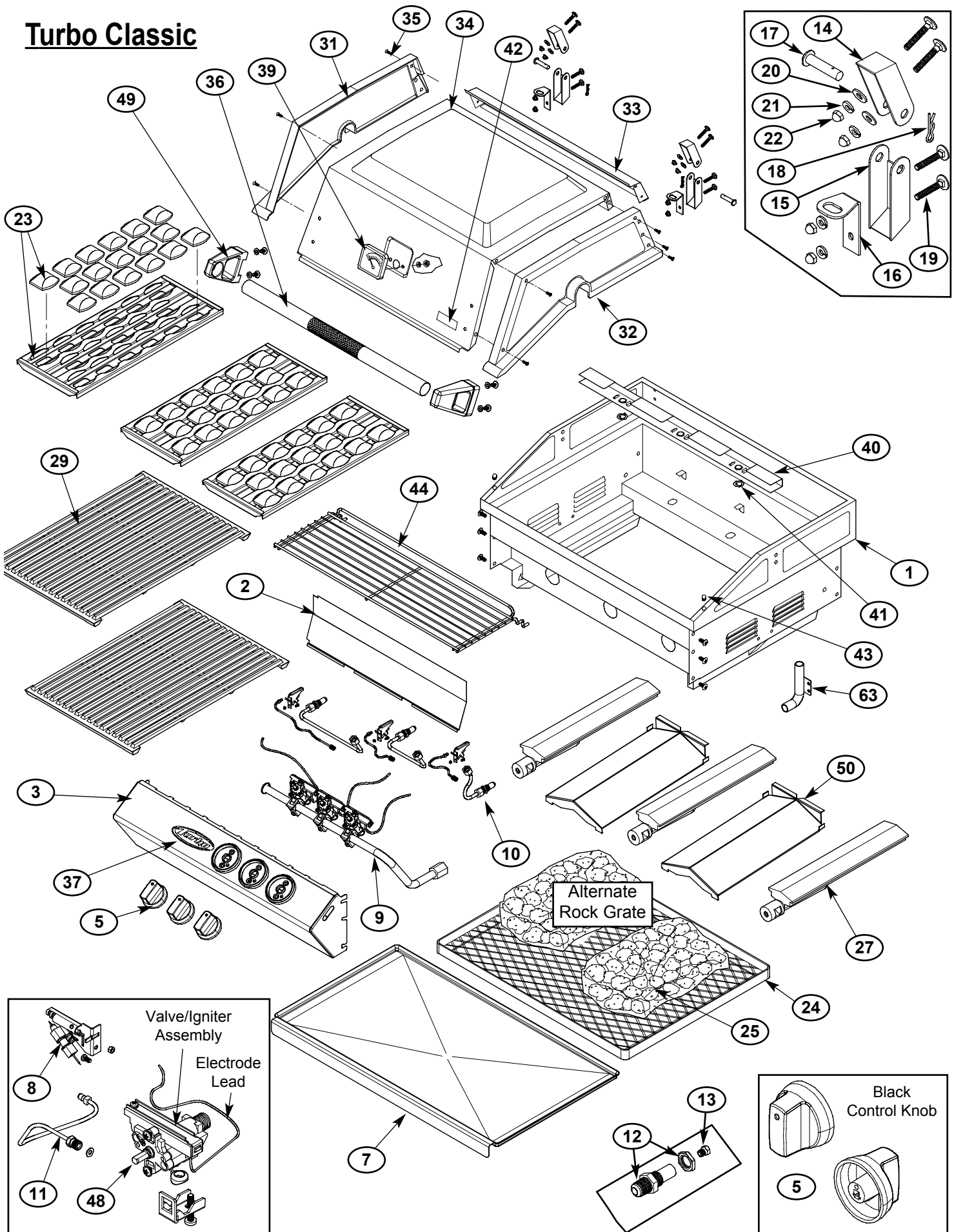

Turbo Elite

