



**ELECTRIC DEEP FRYER**  
***FRITEUSE ELECTRIQUE***  
**FREIDORA ELECTRICA**  
***FRITADEIRA ELÉTRICA***



**Instructions for use**

***Mode d'emploi***

**Instrucciones para el uso**

***Instruções de uso***



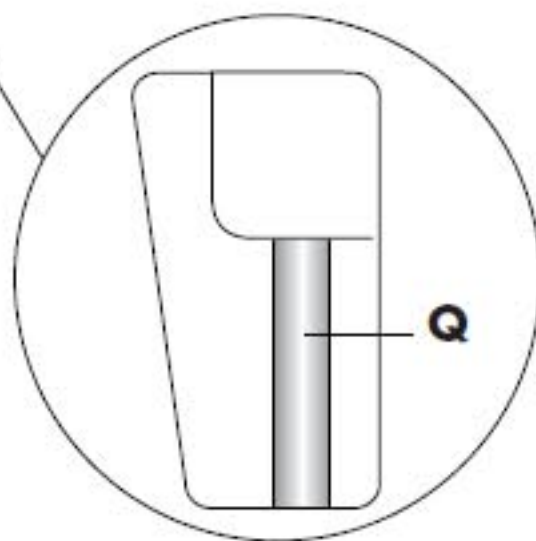
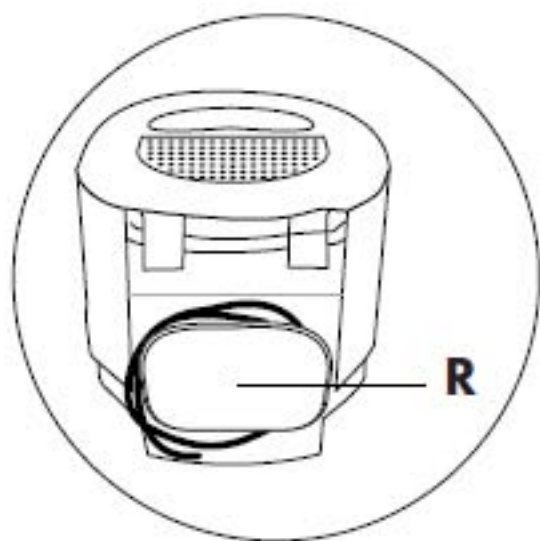
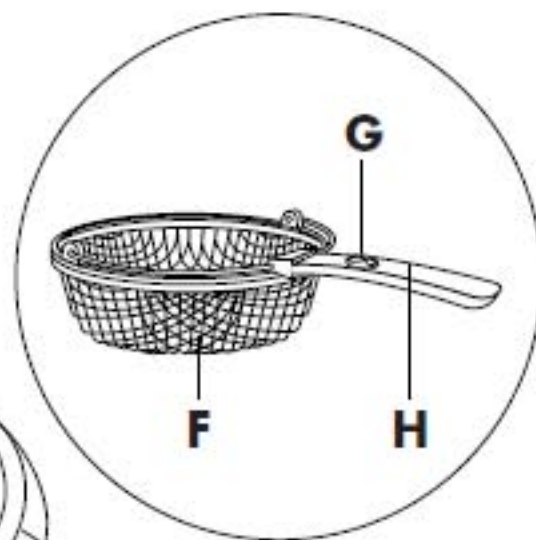
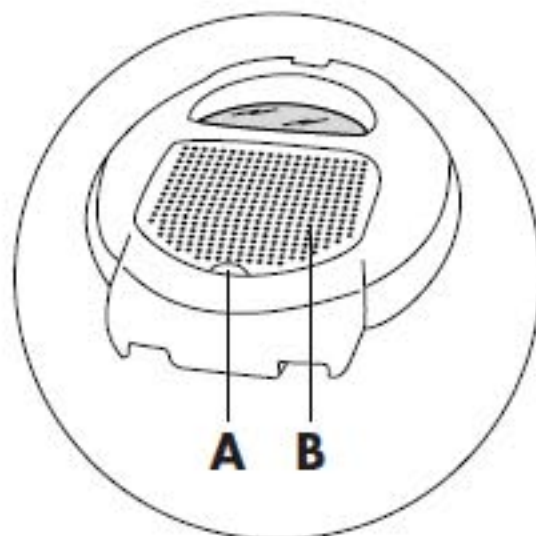
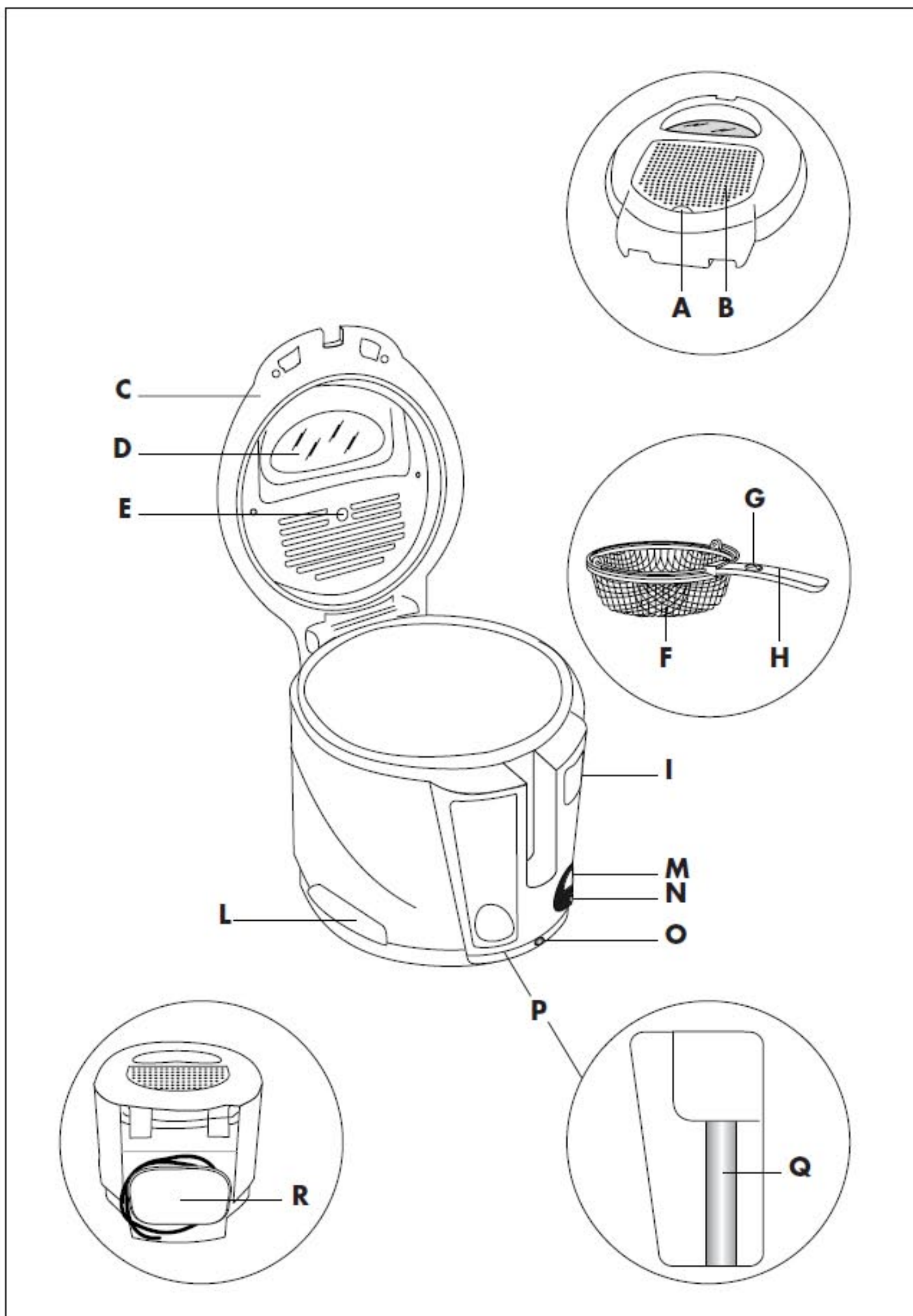

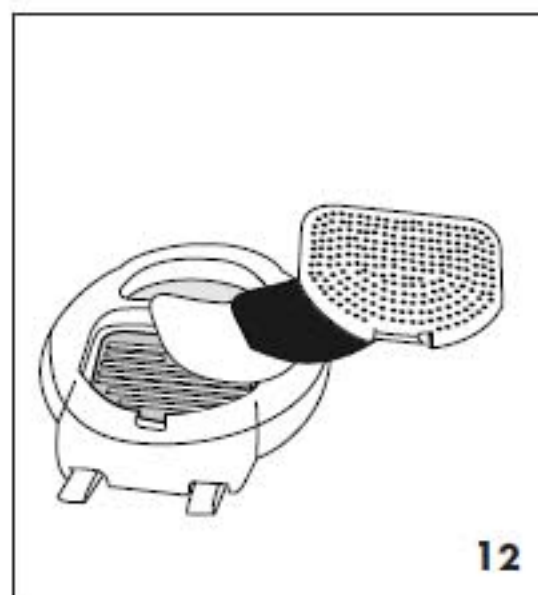
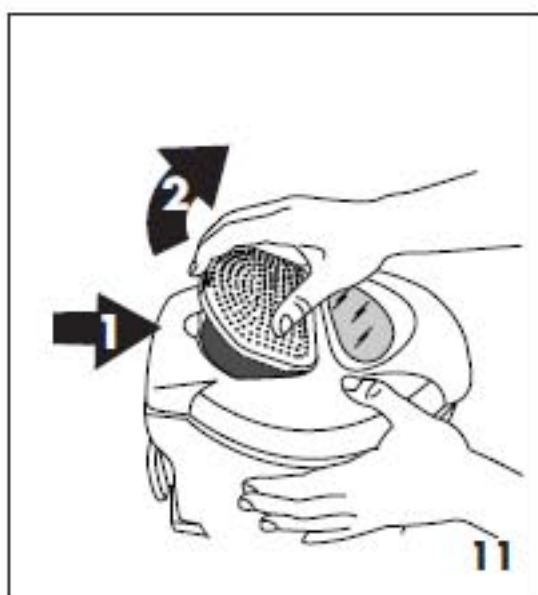
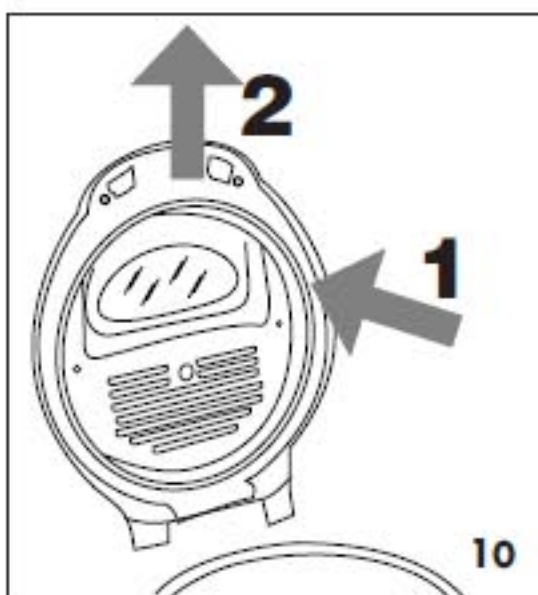
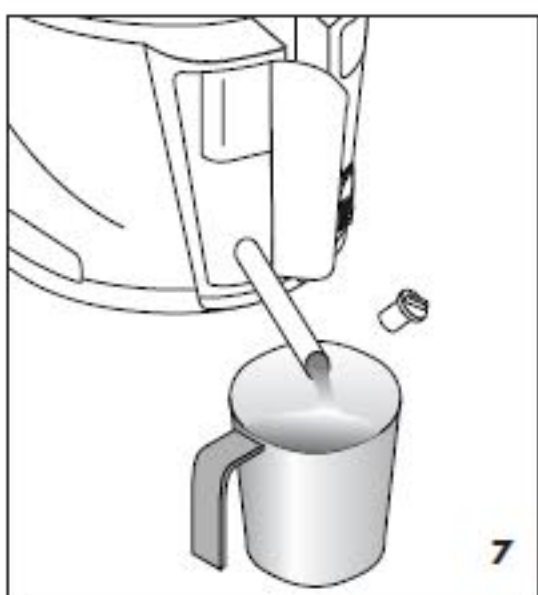
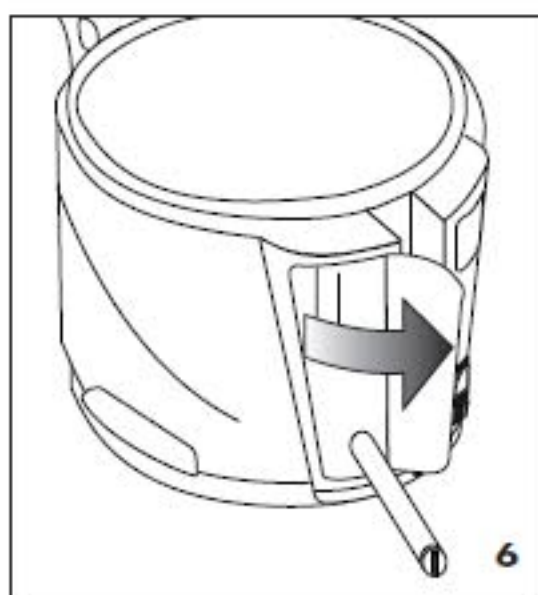
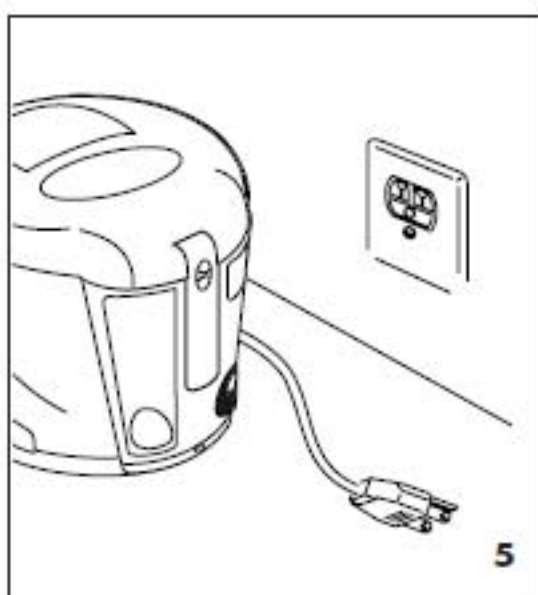
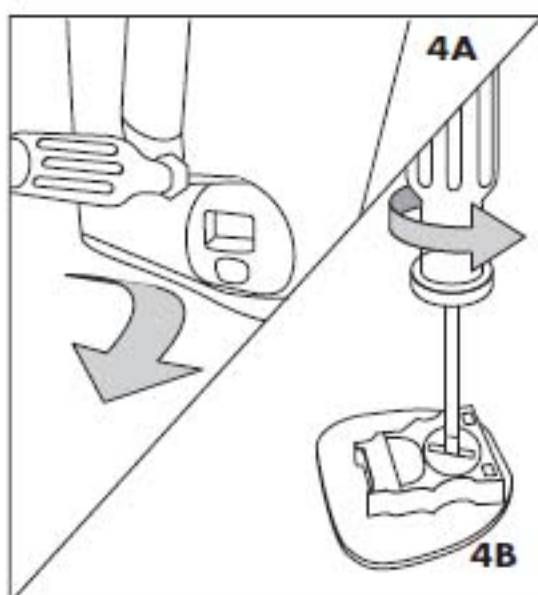
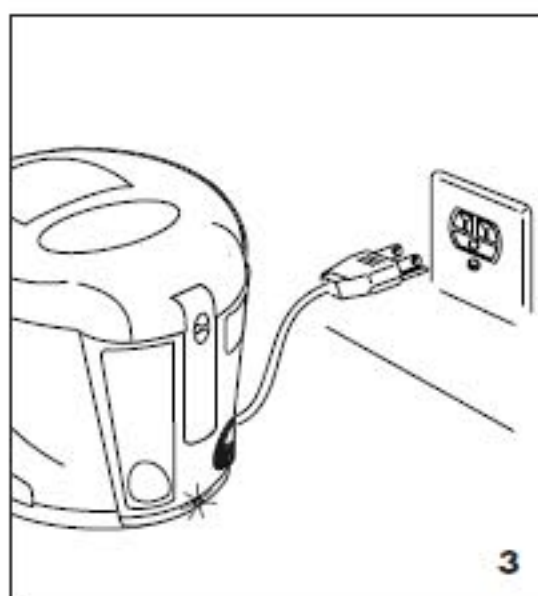
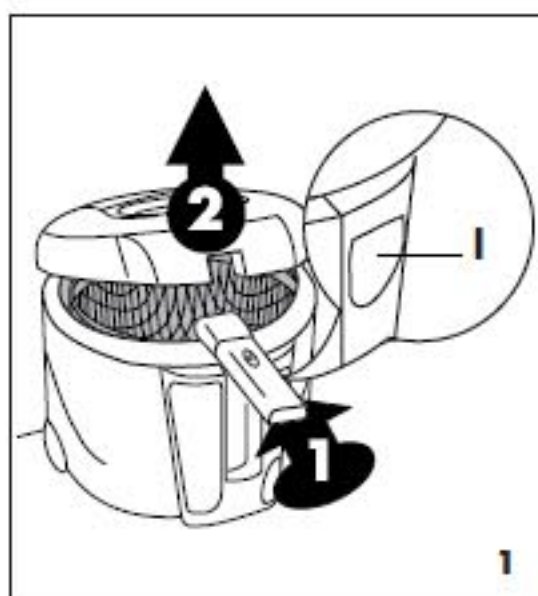
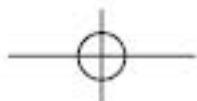



## IMPORTANT SAFEGUARDS

When using electrical appliances, basic safety precautions should always be followed, including the following:

1. Read all instructions.
2. Do not touch hot surfaces. Use handles and knobs.
3. To protect against electric shock do not immerse cord, plug and fryer in water or other liquid.
4. Close supervision is necessary when any appliance is used by or near children.
5. Unplug from outlet when not in use and before cleaning. Allow to cool before putting on or taking off parts, and before cleaning the appliance.
6. Do not operate any appliance with a damaged cord or plug or after the appliance malfunctions, or has been damaged in any manner. Return appliance to the nearest authorized service facility for examination, repair or adjustment.
7. The use of accessory attachments not recommended by the appliance manufacturer may cause injuries.
8. Do not use outdoors.
9. Do not let cord hang over edge of table or counter, or touch hot surfaces.
10. Do not place on or near a hot gas or electric burner or in a heated oven.
11. Extreme caution must be used when moving an appliance containing hot oil or other liquids.
12. Always attach plug to appliance first, then plug cord into the wall outlet. To disconnect, turn the thermostat to the "OFF" position, then remove plug from wall outlet.
13. Do not use appliance for other than intended use.
14. Be sure handle is properly assembled to basket and locked in place. See detailed assembly instructions.

## SAVE THESE INSTRUCTIONS THIS PRODUCT IS FOR HOUSEHOLD USE ONLY

### WARNING

- Do not use the fryer without oil. The fryer will be severely damaged if heated dry.
- This fryer has a thermal cut-out, thus preventing overheating.
- Plug cord into a 120 volt AC outlet.
- If your product is provided with a polarized alternating current plug (a plug having one blade wider than the other), this plug will fit into the power outlet only one way. This is a safety feature. If you are unable to insert the plug fully into the outlet, try reversing the plug. If the plug should still fail to fit, contact your electrician to replace your obsolete outlet. Do not defeat the safety purpose of the polarized plug.
- Before using the fryer for the first time, wash the aluminum pot, basket and lid (remove the filter) thoroughly with hot soapy water, carefully dry the aluminum pot to maintain its attractive finish.
- Should the fryer leak, contact your nearest Service Center or authorized Dealer for qualified assistance.
- To assure safe operation, oversized foods or utensils must not be inserted into the fryer.
- Children or infirm persons should not be allowed to use this product unsupervised.
- Children should not be allowed to play with this appliance.
- During use and when the oil is hot, the pipe compartment inspection door must always be closed.
- It is totally normal that, on first use, the appliance emits a "new appliance" smell. If this happens, aerate the room.
- To avoid injury or burns, do not touch any metal parts on the deep fryer because they may be hot!

### DO NOT USE AN EXTENSION CORD

A short power supply cord is provided to reduce the risks resulting from being entangled in or tripping over a longer cord.



## DESCRIPTION OF THE APPLIANCE (pag. 2)

- |   |   |
|---|---|
| <ul style="list-style-type: none"> <li>A Filter cap fastening hook</li> <li>B Anti-odour filter cap</li> <li>C Lid</li> <li>D Inspection window (if provided)</li> <li>E Filter inspection opening</li> <li>F Basket</li> <li>G Handle slider</li> <li>H Basket handle</li> <li>I Lid opening button</li> </ul> | <ul style="list-style-type: none"> <li>L Handle for lifting appliance</li> <li>M Minute timer (if supplied)</li> <li>N Minute timer key (if supplied)</li> <li>O Pilot lamp</li> <li>P Drainage tube panel (if provided)</li> <li>Q Drainage tube "easy clean system" (if provided)</li> <li>R Cord holder (if provided)</li> </ul> |
|---|---|

### WARNING

SERIOUS HOT-OIL BURNS MAY RESULT FROM A DEEP FRYER BEING PULLED OFF A COUNTERTOP. DO NOT ALLOW THE CORD TO HANG OVER THE EDGE OF THE COUNTER WHERE IT MAY BE GRABBED BY CHILDREN OR BECOME ENTANGLED WITH THE USER. DO NOT USE EXTENSION CORD.

**DO NOT DRAPE  
CORD!**



**KEEP FROM  
CHILDREN!**

### IF YOUR DEEP FRYER IS SUPPLIED WITH A CORD SET WITH MAGNETIC CONNECTOR:

First fit the magnetic connector to the appliance, as seen in Figure 13, making sure that the protruding part of the connector (X) is correctly inserted in the corresponding slot on the appliance, and then plug the cable into the power outlet.

#### Warning

Never leave the appliance plugged into the power outlet if the magnetic connector is not fitted to the deep fryer, Figure 14.

If the magnetic connector does not remain in place, check that it has been inserted correctly, see Figure 13. If the problem persists, contact an authorised service centre.

When the appliance is powered, always leave some free space around the magnetic connector, so as to prevent it from becoming detached.

Only use a type TA-35PA cord set supplied by De'longhi authorised service centres.

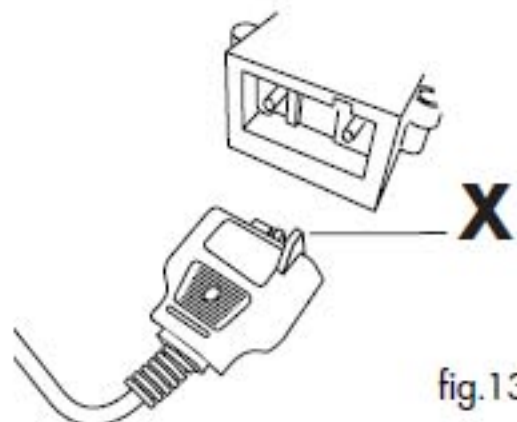

fig.13

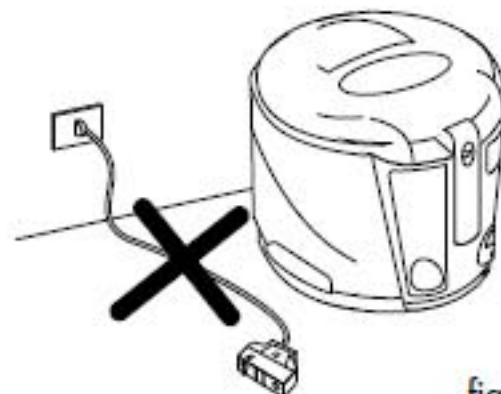

fig.14





## OPERATING INSTRUCTIONS

### FILLING THE BOWL

- Raise the basket into its upper position by lifting upwards on the handle (Fig. 1).
- Push on the (I) button (Fig. 1) and open the lid.
- Remove the basket by pulling it up (Fig. 2).  
The cover must **ALWAYS** be closed whenever the basket is raised or lowered.
- Pour 2 lt. of oil into the bowl (or approx. 1,8 kg./4 lb fat).

*The level of oil in the bowl must always be between the minimum and maximum marks.*

*The maximum level mark should never be exceeded.*

For best results use a good **peanut seed oil**. Olive oil is optimal due to its slower degradation, but prolonged use accentuates its flavour. Above all, avoid mixing different oils.

If using blocks of solid fat, cut into small pieces to avoid fryer heating dry in the first few minutes. The temperature must be set to 150°C until the fat has melted completely. The required temperature can then be set.

Melt solid fat directly in pot. Only when completely melted, should the basket be lowered.

### PRE-HEATING

Turn the appliance on by inserting the plug in the socket and wait for the signal lamp to go off (fig. 3).

1. Place the food to be fried in the basket. Do not overfill the basket (maximum 1 kg/2,2 lb of fresh potatoes).
2. Replace the basket in the bowl in the raised position and close lid by lightly pushing down until catch snaps shut.

### FRYING

As soon as the pilot lamp switches off, move the handle slider in the handle (G) backwards, then move the handle downwards to lower the basket into the oil.

- A considerable quantity of steam will escape from the filter cover, when the basket is lowered into the oil. This is perfectly normal.
- It is also normal for drops of condensation to fall from the lid onto the plastic sides and around the basket handle while in use.
- When basket is lowered into the oil, the inside of the inspection window (if provided) will immediately become steam up. This steam will disappear gra-

dually as the food is cooked.

For models with viewing window, grease the glass door with a little oil before cooking to reduce the accumulation of condensate and thereby improve visibility.

- **Never move the appliance while the oil is still hot.**
- **To move the appliance, use the special lifting handles (L). (Never lift by the basket handle).**

### IN THE MODELS FITTED WITH THE ELECTRONIC MINUTE TIMER

1. Set the cooking time by pressing key (N); display (M) will show the minutes set.
2. The figures will begin flashing immediately afterwards, signifying that the cooking time has started. The last minute will be visualised in seconds.
3. In the event of error, the new cooking time can be set by keeping the button pressed down for more than 2 seconds. The display will reset itself, then repeat as for point 1 (above).
4. The minute timer will show the end of the cooking time with two series of beeps at an interval of about 20 seconds. In order to switch off the audible alarm you only need press minute timer key (N).

**WARNING: the minute timer does not switch the appliance off.**

### REPLACING THE MINUTE TIMER BATTERY (FIG.4)

- Remove the minute timer from its compartment by prying it from the upper side (see fig. 4A).
- Turn the battery cover (fig. 4B) placed on the back in an anticlockwise direction until it is released.
- Replace the battery with another of the same type.
- Remember to dispose of the battery in accordance with the laws currently in force regarding the disposal of toxic products.

### END OF FRYING TIME

When the selected frying time is elapsed, raise the basket and check that food is golden brown as desired. This can be done without opening the lid in models with window.

When the food is cooked, **switch the appliance off by unplugging it** (fig.5). Leave the contents to drip for a moment and then open the lid and remove the basket without shaking it too vigorously.

**For two-stage frying (e.g. potatoes), lift the basket at the**





*end of the first stage, wait for the indicator light to go off and then lower the basket into the oil a second time (see enclosed table).*

### **FILTERING OF OIL OR FAT**

It is advisable to filter the oil or fat after frying in order to remove any food particles, especially if the food is coated in breadcrumbs or flour. Food particles remaining in the oil tend to burn, which causes the oil to deteriorate more quickly.

### **FOR MODELS FITTED WITH A DRAINAGE TUBE**

Proceed as follows:

1. Raise the lid of the fryer and remove the basket. **Check that the oil is sufficiently cool** (about 2 hours).
2. Open the panel (P) and remove the drainage tube (Q) as shown in fig. 6.
3. Remove the cap (fig. 7). Take care to pinch the end of the tube with two fingers so that the oil does not drain until the tube has been placed in a receptacle.
4. Drain the oil into a suitable receptacle (fig. 7)
5. Use a sponge or a paper kitchen towel to remove any deposits from the bowl.
6. Replace the drainage tube in its compartment. **Do not forget to replace the cap.**
7. Place the filter supplied with the appliance in the bottom of the basket (fig. 8). Spare filters can be obtained from your dealer or from our service centres.
8. Pour the oil very slowly into the basket, ensuring that it does not overflow from the filter (fig. 9).

**Note:** After filtering the oil, it can be left in the fryer. However, should a long period of time pass between one frying and the next, it is advisable to store the oil in a closed container, not exposed to direct light in order to avoid its deterioration.

To drain the oil into the receptacle, remove the drainage tube and proceed as shown in fig. 7.

Oil used for frying fish should be stored separately from oil used for other foods.

**If fat is used for frying, this should not be allowed to cool too much, otherwise it may solidify.**

### **CHANGING THE ANTI-ODOUR FILTERS**

With time the odour-eater filters placed inside the lid lose their effectiveness. A change of colour in the filter, visible through hole (E) on the inside cover, shows that the filter needs to be changed. To replace it, remove plastic filter cover (fig. 11) by pressing hook in the direction of arrow 1, then raise it in the direction of arrow 2. Replace the filters.

**Note:** The white filter must be inserted first with the black filter on top. The filter cover must be placed over the black filter (fig. 12).

### **CLEANING**

Before cleaning, always remove the plug from the electrical socket.

- **Never immerse the deep fryer in water or hold it under the tap. By getting inside the water would cause short circuiting.**

Do not immerse the lid in water without having first removed the filters.

To clean the boiler pan, proceed as follows:

- **Check that the oil is sufficiently cold (wait about 2 hours)**, then empty out the oil or fat as previously described in the paragraph headed "filtering the oil or fat".
- Remove any deposit from the bottom of the bowl using a sponge or a paper towel.
- Wash the tank with hot water and washing up liquid, then rinse.
- We advise regular cleaning of the basket, with care being taken to eliminate any deposits.
- The basket can be washed in a dishwasher.
- After frying, wipe the outside of the fryer with a soft damp cloth in order to remove any oil smears and condensation.
- Remove the lid by pushing it gently backwards (see arrow 1 fig. 10) and pulling upwards (see arrow 2 fig. 10).
- After washing, dry thoroughly. Remove any water left in the bottom of the container and, in particular, inside the oil drainage pipe. This avoids dangerous spurts of hot oil during use.

### **MODEL WITH NON-STICK BOILER PAN**

To clean the boiler pan use a soft cloth with a neutral detergent never using objects or abrasive detergents.





## COOKING HINTS

### HOW LONG THE OIL OR FAT LASTS

When oil goes below minimum level mark, add new oil. It is advisable to remove the oil from time to time in order to preserve not only the quality of its flavour, but also the digestibility of the fried food.

The number of times the oil can be used depends on the type of food you fry. For example, the oil must be changed more often if food coated in breadcrumbs is fried frequently.

We advise that the oil be completely changed every 5/8 times or it should be completely changed in the following circumstances:

- unpleasant odour
- smoke when frying
- becomes dark in colour.

### FOR PERFECT FRYING

- **The food to be fried should not be lowered into the oil until the the pilot lamp switches off.**
- Do not overfill the basket. Too much food in the basket lowers the temperature of the oil suddenly, with the result that the food will be greasy and unevenly-fried.
- When frying small quantities of food, the temperature of the oil must be set lower than the temperature indicated to avoid the oil boiling too violently.
- Check that the food is sliced thinly and evenly. Thick slices will not be fried throughout, although they will look very attractive on the outside. If the food is evenly sliced, each slice will be perfectly fried at the same time.
- **Be sure to dry the food carefully before frying.** Damp foods - especially potatoes - remains soggy after frying. Foods with a high water content (e.g. fish, meat and vegetables) should be dipped in breadcrumbs or flour. Remember to shake off any excess flour or breadcrumbs before frying.

### FRYING NON-FROZEN FOOD

Bear in mind that the cooking times and temperatures are approximate and must regulated according to the amount of food which is to be fried and to personale taste.

Type of food		Max. Quantity		Time in Minutes
		gr	lb	
Fried potatoes	half portion	500	1,1	1 <sup>a</sup> phase 5 - 6 2 <sup>a</sup> phase 2 - 3
	whole portion	1000	2,2	1 <sup>a</sup> phase 8-10 2 <sup>a</sup> phase 4 - 6
Fish	Squid	500	1,1	8 - 10
	"Canestrelli"	500	1,1	8 - 10
	Scampi	500	1,1	6 - 8
	Sardines	500	1,1	9 - 11
	Baby cuttlefish	500	1,1	8 - 12
	Soles (2)	400	0,9	4 - 6
Meat	Beef cutlets (2)	300	0,6	6 - 8
	Chicken cutlets (2)	300	0,6	4 - 7
	Meatballs (13)	550	1,2	3 - 6
Vegetables	Artichokes	250	0,5	6 - 9
	Cauliflower	400	0,9	7 - 9
	Mushrooms	400	0,9	5 - 8
	Aubergines (4 slices)	100	0,2	5 - 7
	Courgettes	300	0,6	8 - 10







## FRYING FROZEN FOODS

1. Due to their extremely low temperature, frozen foods inevitably lower the temperature of the oil. For good results each time you fry, we recommend you don't exceed the maximum quantities set out in the following table.
2. Frozen foods are frequently covered with a coating of ice crystals, which should be removed before frying. Lower the basket very slowly into the oil in order to ensure that the oil does not boil over. **Before lowering the basket into the oil, ensure that the lid is securely closed.**
3. To obtain best results, do not exceed recommended max. quantity of food.

The cooking time shown in this table are approximate, and may vary according to the initial temperature of the food and to the cooking temperature recommended on the packet.

Food		Max. quantity		Time (minutes)
		gr	lb	
Pre-cooked frozen potatoes		300(*)	0,6(*)	1 <sup>st</sup> phase 5 - 6 2 <sup>nd</sup> phase 2 - 3
Potato croquettes		500	1,1	8 - 9
Fish	Fish-fingers	300	0,6	6 - 7
	Prawns	300	0,6	6 - 7
Meat	Chicken cutlets (2)	200	0,4	7 - 8

(\*) This is the recommended quantity for excellent results. Naturally a larger quantity of frozen potatoes can be fried, taking into consideration that they will be a little more greasy due to the sudden drop in the temperature of the oil, upon immersion.

## TROUBLESHOOTING

Anomaly	Cause	Solution
Unpleasant odours	Anti-odour filter saturated The oil or fat has deteriorated The oil or fat is not suitable	Change the filter Change the oil (or fat) Use a good-quality peanut oil
The oil overflows	The basket has been lowered too quickly into the oil  Too much oil in the fryer  Food not dried sufficiently before immersing in the oil  Recommended max. quantity exceeded	Lower the basket slowly  Reduce quantity of oil in the fryer  Dry the food thoroughly  1 kg/2,2 lb (fresh potatoes)
Oil does not heat	Fryer has been previously switched on without oil in pot causing the thermal cut-out failure. The magnetic connector is not correctly inserted	Contact Service Centre (fuse change necessary) Insert the connector with the jut (X) on the top side Contact the Service Centre





### Limited Warranty

**What Does This Warranty Cover?** We warrant each appliance to be free from defects in material and workmanship. Our obligation under this warranty is limited to replacement or repair, free of charge at our factory or authorized service centers, of any defective part or parts thereof other than parts damaged in transit, which shall be returned to us, transportation prepaid. PLEASE BE ADVISED THAT ANY SHIPPING COST FOR REPLACEMENT ITEMS WILL BE CHARGED TO THE CONSUMER. This warranty shall apply only if the appliance is used in accordance with the factory directions which accompany it, and on an Alternating Current (AC) circuit.

**How Long Does The Coverage Last?** This warranty runs for one year from the date of delivery and applies only to the original purchaser.

**What Does This Warranty Not Cover?** This warranty does not cover defects or damage of the appliance which result from repairs or alterations to the machine outside our factory or authorized service centers, nor shall it apply to any appliance which has been subject to abuse, misuse, negligence or accidents. Also, consequential and incidental damages resulting from the use of this product or arising out of any breach of contract or breach of this warranty are not recoverable under this warranty. Some states do not allow the exclusion or limitation of incidental or consequential damages, so the above limitation may not apply to you.

**How Do You Get Service?** If repairs become necessary or spare parts are needed, please write to:

De'Longhi America Inc.  
Park 80 West Plaza One 4th floor  
Saddle Brook, NJ 07663  
or call Service Tel. No. 1-800-322-3848  
www.delonghiusa.com

De Longhi Canada  
1040 Ronsa Court  
Mississauga, Ontario  
L4w 3y4 CANADA

The above warranty is in lieu of all other express warranties and representations; All implied warranties are limited to the applicable warranty period set forth above. This limitation does apply if you enter into an extended warranty with De'Longhi. Some states do not allow limitations on how long an implied warranty lasts, so the above exclusions connection with the sale or use of its appliance.

**How Does State Law Apply?** This warranty gives you specific legal rights, and you may also have other rights which vary from state to state.

