



GB

DIRECTIONS FOR USE TOASTER-OVEN-BROILER

De'Longhi products are the finest and most versatile products available. Please read this booklet carefully to ensure that you obtain the fullest benefit from your appliance.

F

MODE D'EMPLOI GRILLE- PAIN - FOUR - GRIL

Les produits De' Longhi sont les meilleurs et les plus polyvalents électroménagers disponibles dans le commerce. Nous vous prions de bien vouloir lire attentivement ce mode d'emploi afin de tirer les meilleurs avantages de votre nouvel appareil.

E

INSTRUCCIONES PARA EL USO TOSTADOR - HORNO - GRILL

Los productos De' Longhi son los mejores y los más versátiles del comercio. Les rogamos que lean atentamente este manual, para poder utilizar lo mejor posible este electrodoméstico.

P

INSTRUÇÕES PARA A UTI- LIZAÇÃO DA TORRADEIRA - FORNO - GRELHADOR

Os aparelhos da De'Longhi são os produtos mais requintados e versáteis que existem. Aconselhamos a leitura atenta destas instruções para assegurar a melhor utilização deste aparelho.



De'Longhi



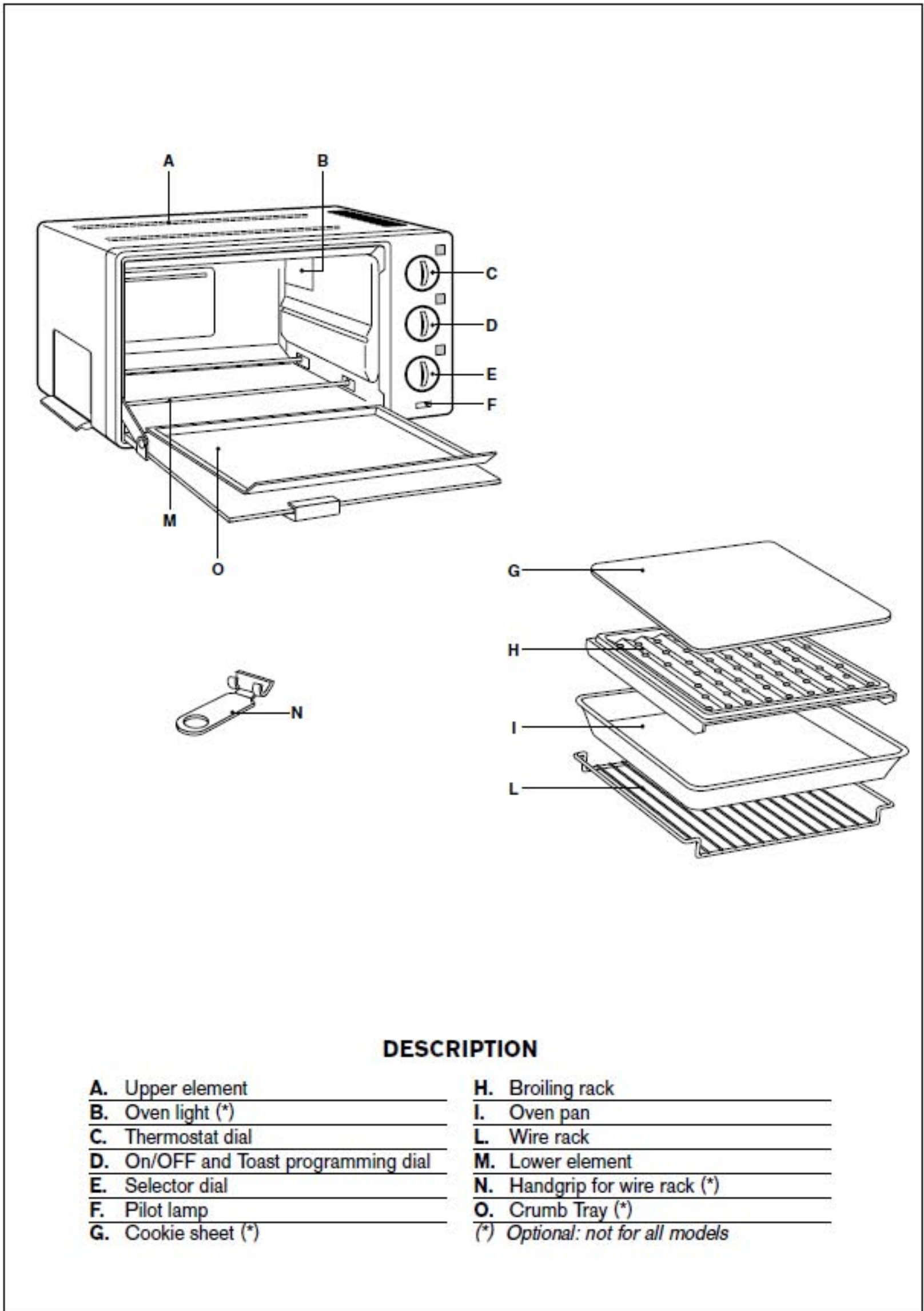

DESCRIPTION

A. Upper element	H. Broiling rack
B. Oven light (*)	I. Oven pan
C. Thermostat dial	L. Wire rack
D. On/OFF and Toast programming dial	M. Lower element
E. Selector dial	N. Handgrip for wire rack (*)
F. Pilot lamp	O. Crumb Tray (*)
G. Cookie sheet (*)	

(*) *Optional: not for all models*





IMPORTANT SAFEGUARDS

When using electrical appliances, basic safety precautions should always be followed, including the following:

1. **READ ALL INSTRUCTIONS.**
2. Do not touch hot surfaces. Use handles or dials.
3. Before using this appliance, move it two to four inches away from the wall or any object on the counter top. **Remove any object that may have been placed on top of the appliance.** Do not use on surfaces where heat may cause a problem.
4. To protect against electrical shock, do not place unit in or under water. See instructions for cleaning.
5. Close supervision is necessary when any appliance is used by or near children.
6. Unplug from outlet when not in use and before cleaning. Always turn the ON/OFF dial to "OFF" and the temperature dial to "●" before unplugging.
7. Do not operate any appliance with a damaged cord or plug or after the appliance malfunctions, or has been damaged in any manner. Return appliance to the nearest authorized service facility for examination, repair or adjustment.
8. The use of accessory attachments not recommended by the appliance manufacturer may cause injuries.
9. Do not use outdoors.
10. Do not let cord hang over edge of table or counter, or touch hot surfaces.
11. Do not place on or near a hot gas or electric burner.
12. Extreme caution must be used when moving an appliance containing hot oil or other hot liquids.
13. If the plug gets hot, please call a qualified electrician.
14. Do not use this appliance for other than intended use.
15. Use extreme caution when removing the oven pan or disposing of hot grease.
16. Do not clean with metal scouring pads. Pieces can break off the pad and touch electrical parts, creating a risk of electric shock.
17. To assure safe operation, oversized foods or utensils must not be inserted into the oven.
18. A fire may occur if this appliance is covered or touching flammable material, including curtains, draperies, walls, etc., when in operation.
19. **CAUTION:** Never leave the toaster-oven-broiler unattended when in use (especially when broiling and toasting).
20. When broiling, the oven-pan, the broiling rack and wire rack must be used according to the instructions on page 7.
21. Extreme caution should be exercised when using containers other than oven proof metal glass or ceramic.
22. Do not store any materials, other than the manufacturer's recommended accessories, in the oven when not in use.
23. Do not place any of the following materials in the oven: paper, cardboard, plastic and the like.
24. Do not cover any part of the oven with metal foil. This will cause overheating of the oven.
25. To switch off the toaster-oven broiler, turn the ON/OFF dial to "OFF" and the temperature dial to "●".

THIS PRODUCT IS FOR HOUSEHOLD USE ONLY
SAVE THESE INSTRUCTIONS

WARNING: Once having removed the appliance from the packaging, check that the door is intact. As the door is made from glass, it is fragile, and should be replaced if visibly chipped, scored or scratched. Furthermore, when using, cleaning or moving the appliance, do not slam or bang the door or pour cold liquids on the glass when the appliance is hot.





SUMMARY OF OPERATION

Program	Position ON/OFF and toast programming dial	Position of thermostat dial	Position of function selector dial	Position of wire rack/accessories	Notes and tips
Keep warm	ON	KEEP WARM	BAKE/TOAST		Turn to this setting to keep hot food warm. Do not hold food more than an hour or reheat cold food. If not hot enough for serving turn temperature dial up.
Bake	ON	UP TO 470 °F	BAKE/TOAST		Ideal for meat, pizza, cakes, bake casseroles, fruit desserts, fish, stuffed vegetables, puddings and other moist foods that do not require browning and crisping.
Broil	ON	BROIL	Broil	 Lower position Upper position	Always use the broiling rack (H) set in the oven pan (I). The oven pan with the broiling rack are shown in the two broiling positions: Use the UPPER POSITION when a faster browning and broiling time is required. Place the broiling rack with side well turned downwards to rest in the pan. Allow 1 inch between the food and the upper element (A). Ideal for foods such as hamburgers, steaks, kebabs. Use the LOWER POSITION for foods that require a longer broiling time such as chicken. For the lower position, turn the broiling rack so that it rests in the pan with its side walls upwards.
Top broiling	ON or Up to 7 minutes	BROIL	Broil		Use the broil settings to top-brown open-face sandwiches, cheese toppings, hors d'oeuvres. When using for the first time keep an eye on the food and reduce the operating time so that over browning is thus avoided.
Toast	Up to 7 minutes	TOAST	BAKE/TOAST		Set the ON/OFF dial to the color desired. Some breads, muffins etc. will take longer than others. Reset dial if results are too light.
Sandwich	Up to 7 minutes	TOAST	BAKE/TOAST		Place the bread to be toasted following instructions on page 8.





- Your product is equipped with a polarized alternating current line plug (a plug having one blade wider than the other). This plug will fit into the power outlet only one way. This is a safety feature. If you are unable to insert the plug fully into the outlet, try reversing the plug. If the plug should still fail to fit, contact your electrician to replace your obsolete outlet. Do not defeat the safety purpose of the polarized plug.
- Plug the cord into a 120 volt AC outlet.
- The cord length of this product has been selected to reduce the possibility of tangling in or tripping over a longer cord. If more cord length is needed, an extension cord may be used. It should be rated no less than 15 amps., 120 volts, and have Underwriters Laboratories/CSA listing.
- A six feet long, 15 amp. extension cord may be purchased from your local authorized service facility. When using a longer cord, be sure not to let it drape over the working area or dangle where someone could accidentally pull or trip over it.
- Handle the cord carefully for longer life; avoid jerking or straining the cord at the plug and appliance connections.

- **Note:**

Initial start up operation may result in minimal smell and smoke (about 15 min.). This is normal. It is due to the protective substance on heating elements which protects them from salt effects during shipping from factory.

OPTIONAL ACCESSORIES

- **COOKIE SHEET (G)**

Must be placed directly on the wire rack. Indispensable for baking biscuits and pastries.

- **OVEN LIGHT (B) AND PILOT LAMP (F)**

- If the oven light (B) has been provided for, said light will remain turned ON when the oven is in function. The pilot lamp (F) will turn OFF once the selected baking temperature inside the oven is reached and will turn on and off during cooking.
- If your oven is not provided with the oven light (B), the pilot lamp (F) will light continuously when the oven is switched on (it will not have the function of a temperature indicator).

- **HANDGRIP FOR WIRE RACK (N)**



Use handgrip to bring the wire rack out of the oven when it is hot.

COOKING PROGRAMMES

1. HOW TO KEEP FOOD WARM

Place the food to be kept warm on the wire rack

- Set the thermostat dial (C) to the "KEEP WARM" position.
- Set the ON/OFF (D) dial to the "ON" position.
- Set the function selector dial to the "TOAST BAKE" position.

Once the "keep warm" function is no longer needed, turn the thermostat dial to "●" and the ON/OFF dial to OFF.

This feature is designed to keep foods warm, after they are cooked for short periods of time without overcooking. We do not recommend keeping foods warm for prolonged periods or using this feature to reheat frozen or cold foods.

2. INSTRUCTIONS FOR BAKING

You can bake foods in your oven, just as in your regular oven. Casseroles or baking dishes may be placed directly on the removable wire rack (L). Use the oven pan (I) (or cookie sheet, if provided) to bake such items as cookies, biscuits, rolls and uncovered casserole dishes. Place the oven pan or the cookie sheet directly on the removable wire rack (please refer to the table on page 4 for wire rack position).

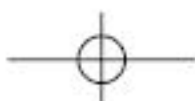

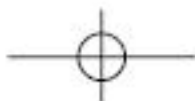

1. Close the door
2. Set the thermostat dial (C) to the desired position/ temperature
3. Turn the ON/OFF timer dial to "ON"
4. Turn the function selector dial to the TOAST/BAKE position.
5. **When baking is finished turn the thermostat dial to the " ● " position and the ON/OFF dial to the "OFF" position.**

• **NOTE:**

We do not recommend the use of glass covers on casseroles. Glass cooking dishes should never be closer than one inch from the heating element.



- **During the bake and toast function, do not put the oven pan (or any other accessory/container) directly on the lower heating element.**

• **HELPFUL BAKING HINTS**

To obtain best performance from this toaster-oven-broiler:

- Do not overfill the oven. Whenever possible, place foods in center of oven.
- Avoid opening the door too frequently to prevent heat loss.
- Foil may be used to cover the baking dish or pan. Be sure the ends of foil are tucked closely against the edge of the baking dish/pan.

• **TEMPERATURE AND TIME FOR TYPICAL FOODS (baking and roasting)**

The suggested temperature and times will vary depending on the temperature of the food placed in the oven, the quantity and personal preference. Times given for meat and poultry are for refrigerator temperature. **Add five minutes for preheating the oven.** In order to avoid overcooking when using for the first time we suggest you to set a low temperature. As you use the oven, the best settings will become familiar.

Food	Temperature setting	Approximate time	Notes and tips. (For wire rack position refer to table on page 4)
Whole chicken 2,5-3 lbs. Unstuffed	400 °F	80-90 min. or until internal temperature of 175 °F in thigh and breast	Turning at half of cooking time is not required. It is possible to cook also above the broiling rack inverted (lower position) inside the oven pan, in order to reduce spattering.
Pork loin or Rib Roast 2-3 lbs	400 °F	80-90 min. or until internal temperature of 170 °F is reached	Roast as for whole chicken.
Beef Sirloin or Rib Roast 3 lbs	400 °F	60-70 min. or until tender and brown	No turning is needed.
Meat loaf 2-2,5 lbs	350 °F	50-60 min.	Use the oven pan. No turning is needed. Mix and beat together 1,5 -2 lbs of minced meat (beef). With eggs, bread-crumbs, salt, pepper and flavouring.
Baking potatoes 3-4 large cut into pieces	400 °F	50-60 min.	Cut the potatoes into small pieces, use the oven pan, mix three times when cooking and after at least 20 minutes.
Loaf cakes	350 °F	Follow traditional recipe timing (slightly lowered)	Use metal rectangular moulds.
Pies, uncovered	350 °F	Follow traditional recipe timing (slightly lowered)	Use metal moulds for cakes
Cookies: drop rolled and cut, sliced, formed	375 °F	10-15 min.	Insert the rack as for TOASTING function. Use the cookie sheet (G) (if provided) or the oven pan.





• TOP BROWNING

Top browning is ideal for melting, crisping and toasting food surfaces. Use it for open face sandwiches, pre-buttered muffins or browning cooked casseroles.

1. Place the food on the oven pan (or on the cookie sheet, if provided) and place it on the wire rack.
2. Close the door, set both the selector and temperature dials to BROIL.
3. Turn the ON/OFF timer knob to MEDIUM or to ON (for longer browning times)

When experimenting with new uses, watch the food to avoid overbrowning.

When the browning cycle is completed (top surface with desired colour) turn the thermostat dial to "●" and the ON/OFF dial to OFF.

3. INSTRUCTIONS FOR BROILING

Always use the oven pan with the broiling rack for broiling. No preheating of the broiler is necessary.

Do not leave the broiler unattended when in use. Before using the broiler for the first time and after use, wash the pan and the rack with warm, sudsy water. Do not cover the oven wire rack with foil.

This prevents fat and oils from draining, causing spatter and smoking, and also restricts air circulation for proper ventilation.

• BROILING

1. Place the oven wire rack as shown in the table on page 4.
2. Place the food to be broiled on the broiling rack (H) (set inside the oven pan), then put the assembly on the wire rack.
3. **Always leave the oven door open to the stop position (as shown below).**
4. Turn the thermostat dial (C) and the selector dial (E) to "BROIL".
5. Turn the ON/OFF dial to "ON".
6. Turn the function control knob to "BROIL".
7. When broiling is finished, turn the ON/OFF dial to the "OFF" position and the thermostat dial to the "●" position. Care should be taken when turning food, removing the oven pan and disposing of the grease collected while broiling. Use hot pads.

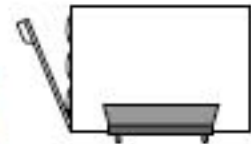

• Note:

While smoke is an inherent characteristic of good broiling, the following tips should eliminate or greatly reduce smoking:

- Trim excess fat from meat and score the edges to prevent curling. Dry meat, fish and poultry surfaces with paper towel.
- For best results, thaw frozen meats before broiling. These two precautions will reduce or eliminate smoke from the broiler.
- Placing the food on the broiling rack allows the juices and fat to drip into the oven pan and decreases spattering while broiling.
- If frozen steaks and chops are broiled, allow 1 and a half to 2 times the required broiling time as that required for unfrozen meat.
- If grease "pops" during broiling, turn the temperature control dial to a lower setting.
- Remove grease from the pan and wash the pan and broiling rack after use.
- The broiler should be cleaned inside after each use. Too much grease accumulation causes smoking. Use any non-abrasive cleaner and hot water.
- For very thick steaks and other thick foods, we recommend using the lower broiling rack position.
- Since fish is non-fatty it can be broiled directly on the oven pan. Broil until it flakes easily with a fork. Thin fillets need not to be turned.



4. DIRECTIONS FOR AUTOMATIC TOASTING

- The capacity of the wire rack (L) is such as to allow the toasting of 6 slices of bread at the same time. In any case better results are obtained with 4 slices.
- For toasting, place the slices of bread as shown below:

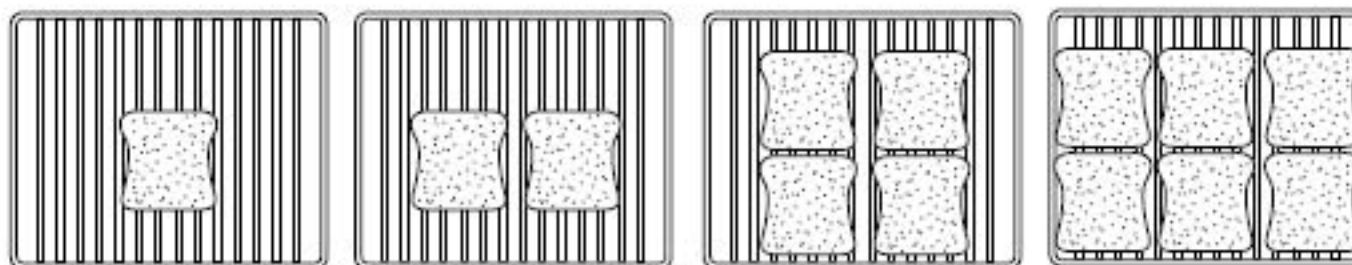

Toasting one slice

Toasting two slices

Toasting four slices

Toasting six slices

For consecutive toasting, turn the toast programming dial to a lower setting.

• INSTRUCTIONS FOR TOASTING

Always use the oven wire rack for toasting bread, sandwiches, English muffins, shelf foods and frozen waffles automatically.

1. Place the wire rack as shown in the table on page 4.
2. Center the food to be toasted on the wire rack. Close the door.
3. Set the thermostat dial to TOAST/BROIL position and the function selector dial to TOAST/BAKE.
4. The toast programming dial (D) can be set clockwise for light, medium or dark toast or any shade desired in between.

When using the toaster-oven-broiler for the first time, set the dial (D) to a medium setting. Toast a few pieces of bread to check for desired brownness. If necessary, adjust the control to suit your preference.

5. When toasting, both the top and bottom heating element switch on to brown both sides of the food at the same time. Condensation may build up on the inside of the glass door. This is normal.

The condensation will evaporate during the toasting cycle.

6. A ring indicates the end of the set time. The toasting cycle has been completed and the heating elements will shut off automatically. Turn the thermostat dial to the "●" position.

• Note:

This toaster-oven-broiler is capable of toasting in a wide range of colours, automatically from light to dark. However, if you prefer a lighter shade of toast, simply interrupt the automatic toast cycle by turning the ON/OFF knob to "OFF". This will shut the unit off without damaging the oven.

If you prefer a darker shade, restart the toasting cycle by turning the dial (D) clockwise until the desired colour is obtained.

Then switch off manually the thermostat dial and the toast programming dial as described earlier.

As you use the oven, the best settings for favourite breads will become familiar.

• HINTS FOR TOASTING SUCCESS

Heavier breads and frozen breads will require a darker setting. One slice of bread will require a lighter setting than several slices.





CLEANING AND MAINTENANCE

Always unplug the toaster-oven-broiler and allow it to cool before cleaning. This unit has been designed and engineered with your safety in mind. To assure maximum safe operation, keep unit clean free of grease and build up of food particles.

1. Remove the wire oven rack.
2. To clean the inside walls, use a damp cloth and a mild liquid soap solution. Never use harsh abrasives, corrosive products or spray detergents.

- **Note:**

Do not clean interior with metal scouring pads. Pieces can break off and touch electrical parts, creating risk of electrical shock.

3. To clean the glass door, use a glass cleaner or a damp cloth. Wipe dry with a clean cloth.
4. To clean the exterior finish, use a damp, sudsy cloth. For stubborn stains, a non-abrasive liquid cleaner or spray glass cleaner may be used. Do not use metal scouring pads, as they might mar the finish. Always remove cleaning agents by polishing with a dry cloth.
5. The wire rack, the oven pan and the broiling rack may be washed as other kitchen ware.

- **CLEANING THE BOTTOM OF THE OVEN**

If your oven has a bottom that can be opened:

To clean the bottom of the oven, open the access panel by pressing the latch spring then pull the access panel downwards. (see fig. A/B). Place the oven on its rear panel. This will make cleaning easier.

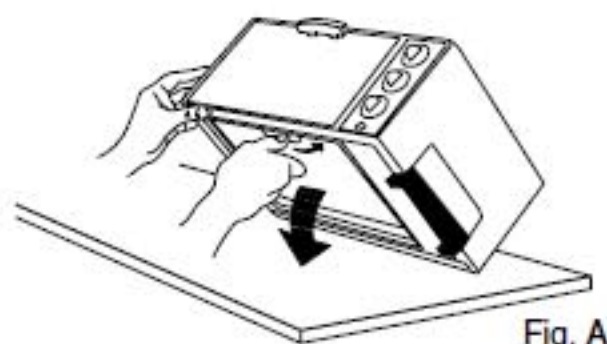

Fig. A



Fig. B

Clean the oven floor after use to avoid build-up of residue, as this will affect the cooking performance. Brush off crumbs or wipe the oven floor with a damp cloth. For stubborn stains, use a nylon or plastic scouring pad or a non-caustic cleaner, dry thoroughly before closing.

After cleaning, close the access panel and check that it is locked securely into position.

If your oven has a crumb tray:

Slide the crumb tray out from under the bottom of your oven (see Fig. C). Wash by hand. Should the soilage be difficult to remove, rinse the crumb tray with hot soapy water and if necessary, scour it delicately, without scratching it.

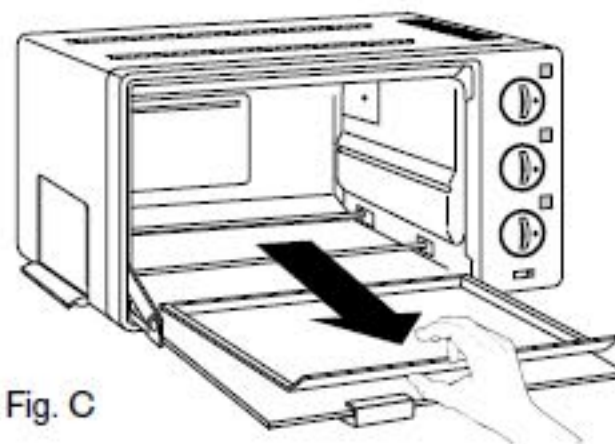

Fig. C

- **OTHER SERVICING**

Any servicing requiring disassembly should be performed by an authorized service representative.

- **OVEN LIGHT (optional)**

The oven may be used safely even if the oven light is not working. Contact an authorized service representative for bulb replacement.



**DeLonghi**

Limited Warranty

What Does This Warranty Cover? We warrant each appliance to be free from defects in material and workmanship. Our obligation under this warranty is limited to replacement or repair, free of charge at our factory or authorized service centers, of any defective part or parts there of other than parts damaged in transit, which shall be returned to us, transportation prepaid. This warranty shall apply only if the appliance is used in accordance with the factory directions which accompany it, and on an Alternating Current (AC) circuit.

How Long Does The Coverage Last? This warranty runs for one year from the date of delivery and applies only to the original purchaser for use.

What Does This Warranty Not Cover? This warranty does not cover defects or damage of the appliance which result from repairs or alterations to the machine outside our factory or authorized service centers, nor shall it apply to any appliance which has been subject to abuse, misuse, negligence or accidents. Also, consequential and incidental damages resulting from the use of this product or arising out of any breach of contract or breach of this warranty are not recoverable under this warranty. Some states do not allow the exclusion or limitation of incidental or consequential damages, so the above limitation may not apply to you.

How Do You Get Service? If repairs become necessary or spare parts are needed, please write to:

De'Longhi America Inc.

Park 80 West Plaza One 4th floor
Saddle Brook, NJ 07663
or call Service Tel. No. 1-800-322-3848

De' Longhi CANADA

1040 Ronsa Court
MISSISSAUGA, ONTARIO
L4W 3Y4 CANADA

The above warranty is in lieu of all other express warranties and representations; All implied warranties are limited to the applicable warranty period set forth above. This limitation does apply if you enter into an extended warranty with De'Longhi. Some states do not allow limitations on how long an implied warranty lasts, so the above exclusions may not apply to you. De' Longhi does not authorize any other person or company to assume for it any liability in connection with the sale or use of its appliance.

How Does State Law Apply? This warranty gives you specific legal rights, and you may also have other rights which vary from state to state.

