

This Owner's Manual is provided and hosted by [Appliance Factory Parts](http://www.appliancefactoryparts.com).

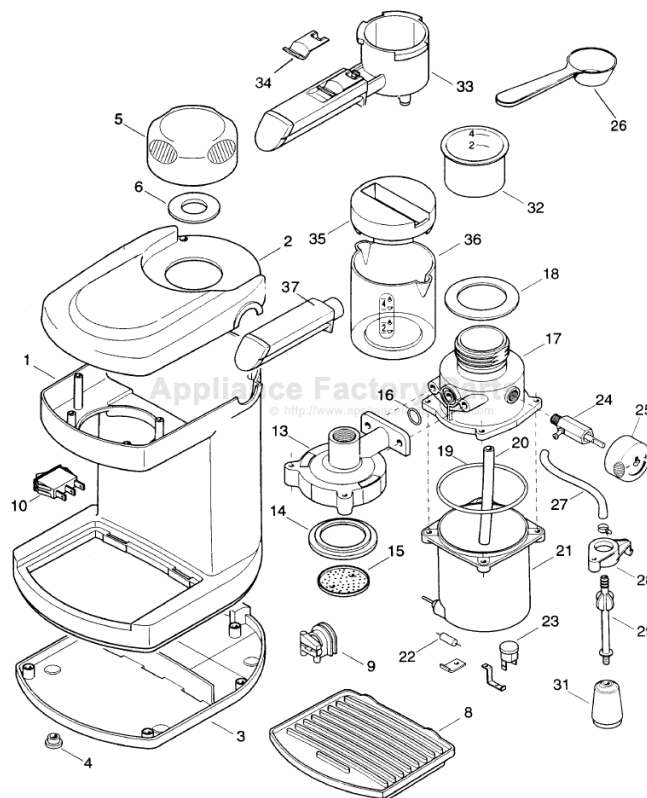

# DE'LONGHI BAR4U Owner's Manual

[Shop genuine replacement parts for DE'LONGHI BAR4U](#)



[Find Your DE'LONGHI Coffee Maker Parts - Select From 289 Models](#)

----- Manual continues below -----

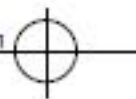

# COFFEE MACHINE



Owner's

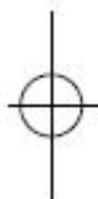

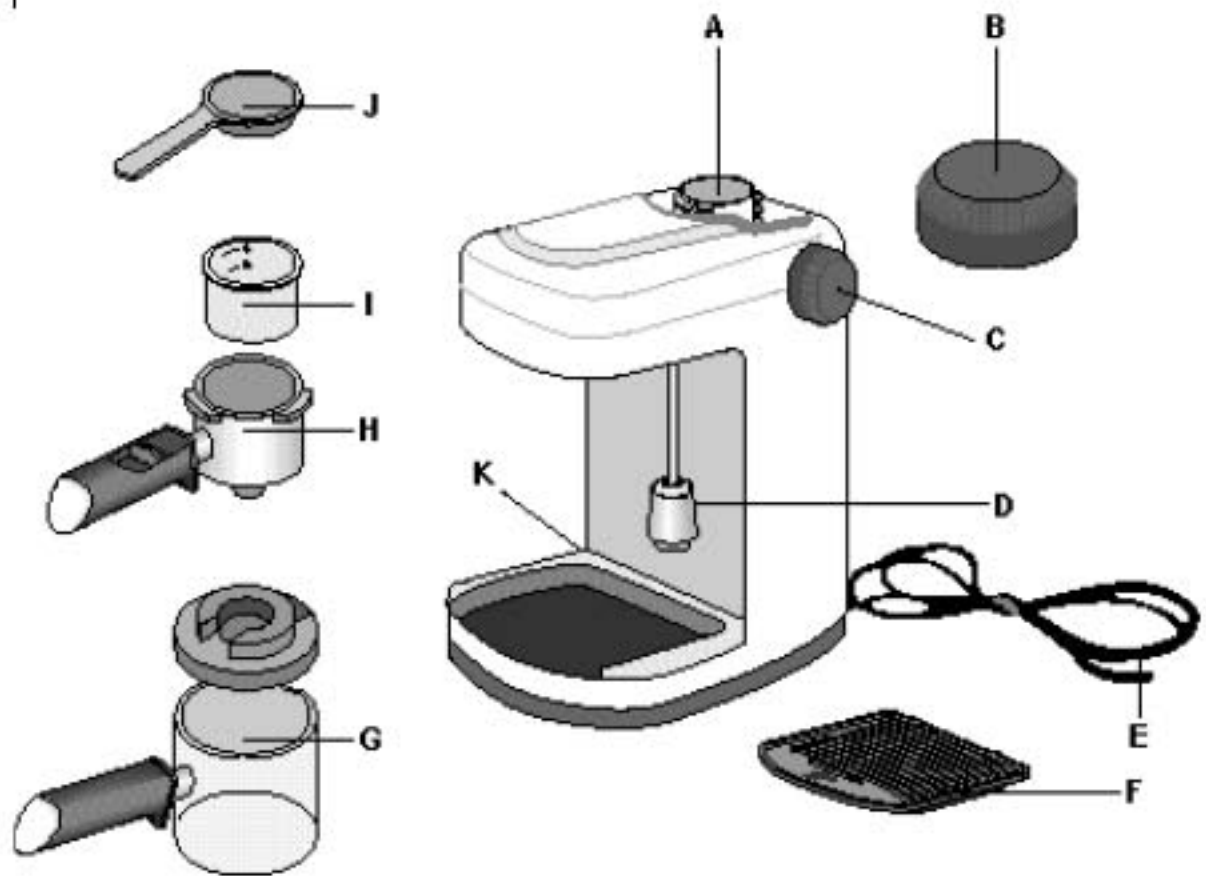

## DESCRIPTION OF THE APPLIANCE

(the following terminology and letters of reference will be used continuously in the following pages:)

- |    |                                   |    |                 |
|----|-----------------------------------|----|-----------------|
| A. | Boiler                            | G. | Carafe with lid |
| B. | Boiler cap                        | H. | Filter holder   |
| C. | Steam knob                        | I. | Filter          |
| D. | Steam tube with cappuccino nozzle | J. | Measuring spoon |
| E. | Power cable                       | K. | ON/OFF Switch   |
| F. | Drip tray                         |    |                 |

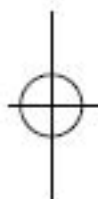
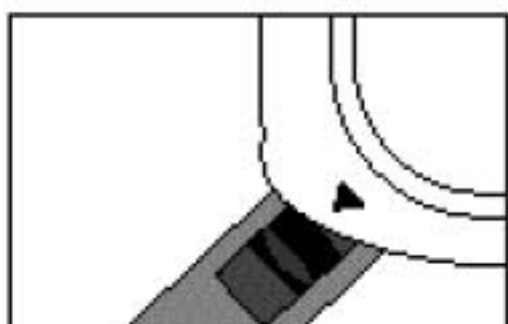
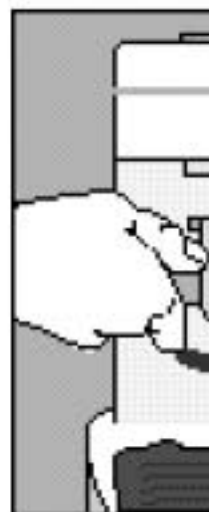
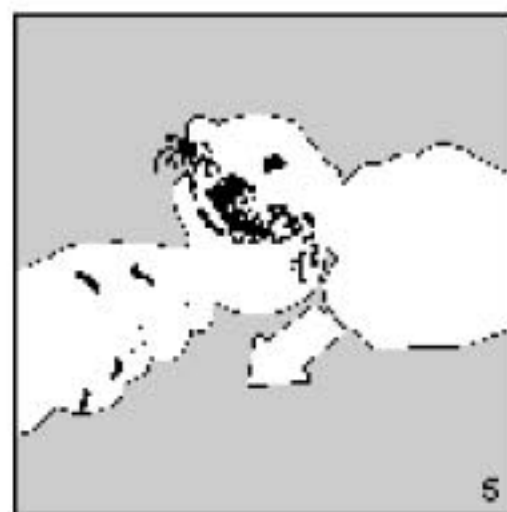
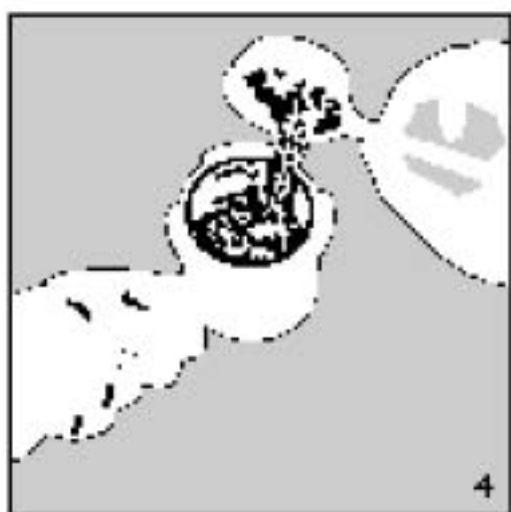
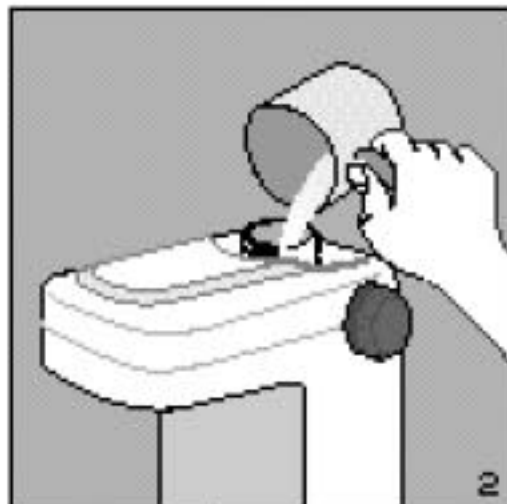
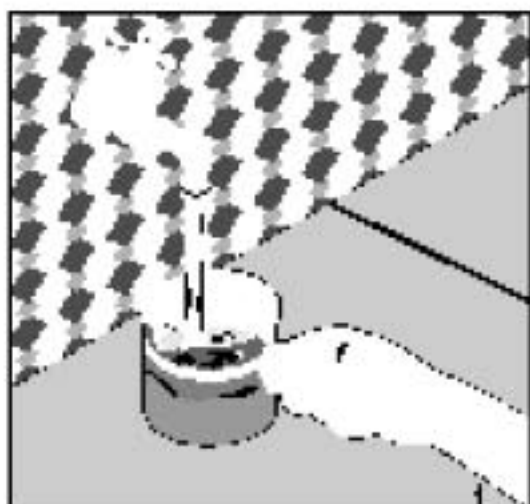
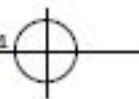

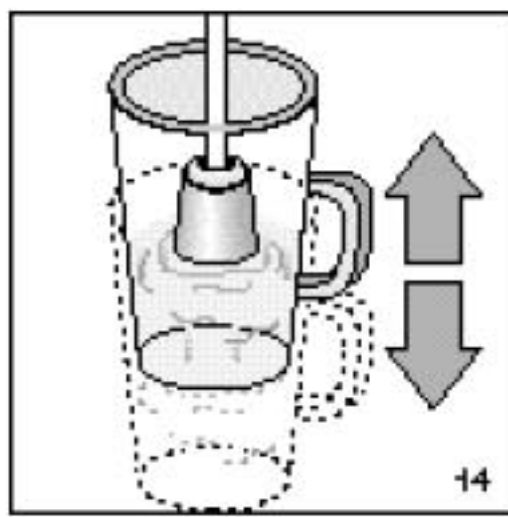
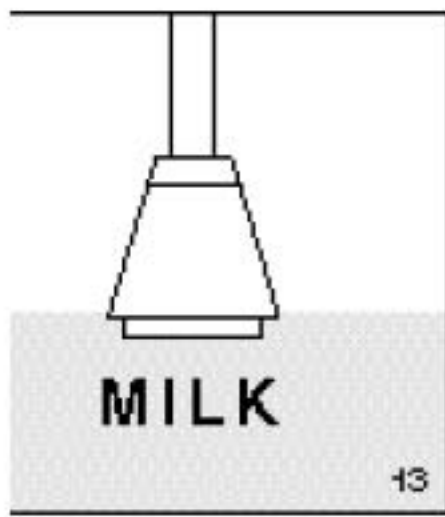
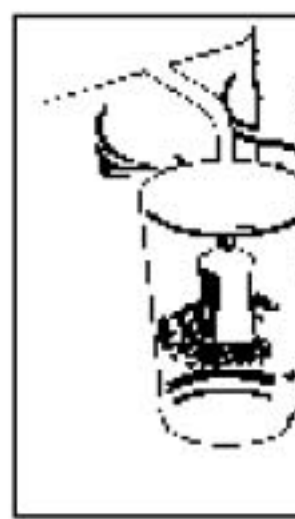
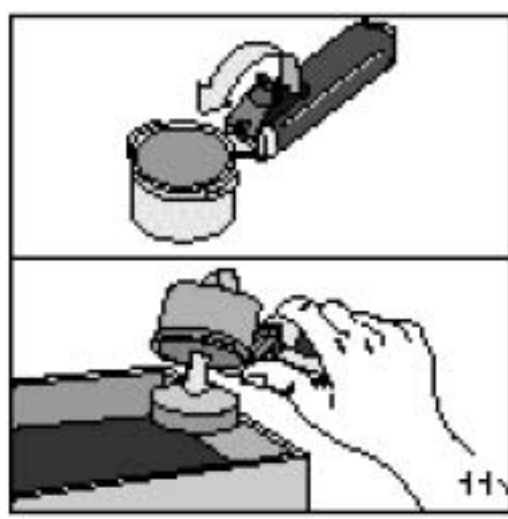



## IMPORTANT SAFEGUARDS

When using electrical appliances, basic safety precautions should always be followed. The following:

- Read all instructions.
- Do not touch hot surfaces. Use handles and knobs.
- To protect against fire, electrical shock and personal injury, do not immerse cord, plug, water or other liquid.
- Close supervision is necessary when any appliance is used by or near children.
- Unplug from the outlet when not in use and before cleaning. Allow to cool before fitting parts, and before cleaning the appliance.
- Do not operate with a damaged cord or plug, or after the appliance malfunctions or is damaged in any manner. Return the appliance to the nearest authorized service facility for repair or adjustment.
- The use of accessory attachments or spare parts not recommended by the appliance manufacturer may result in fire, electrical shock or personal injury.
- Do not use outdoors.
- Do not let the cord hang over the edge of the table or counter, or touch hot surfaces.
- Do not place on or near a hot gas or electrical burner, or in a heated oven.
- To disconnect the appliance, turn any control to "off", then remove plug from wall outlet.
- Do not use the appliance for other than the intended use.
- This appliance is for household use only.

## SAVE THESE INSTRUCTIONS

## SHORT CORD INSTRUCTIONS

- A short power cord is provided to reduce risks resulting from becoming entangled in a longer cord.
- Longer, detachable power supply cords or extension cords are available and may be used when exercised in their use.
- If an extension cord is used, the marked electrical rating should be at least as great as that of the appliance. The longer cord should be arranged so that it will not drape over the counter top where it can be pulled on by children or tripped over.
- Your product is equipped with a polarized alternating current line plug (a plug having one flat blade the other). This plug will fit into the power outlet only one way. This is a safety feature. If the plug will not insert the plug fully into the outlet, try reversing the plug. If the plug should still fail to insert, call an electrician to replace your obsolete outlet. Do not defeat the safety purpose of the polarized plug.

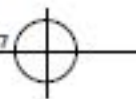

## PREPARING EXPRESS COFFEE

- 1 Remove boiler cap by turning it counter-clockwise.
- 2 Using the carafe supplied (fig. 1) pour water in the boiler (fig. 2) according to the quantities shown in the table at the end of the text. **Do not exceed the quantities shown as this could cause malfunctioning of the appliance.**  
While filling the boiler make sure switch is in the OFF position.
- 3 Carefully close the boiler cap by turning it clockwise.
- 4 Insert filter into the filter-holder. (fig. 3).
- 5 Place coffee evenly into the filter according to the quantities shown in the table at the end of the text (fig. 4). It is important to use middle grounded coffee. (Avoid using too fine grounded coffee otherwise the filter could be obstructed, MOKA coffee is suitable).
- 6 Remove excess coffee from filter-rim (fig. 5).
- 7 To attach filter holder to machine place to filter holder under the heater-faucet (fig. 6) and line up with the arrow marked on the machine's cover (fig. 7). At this point press filter-holder upwards and at the same time rotate clockwise all the way. It does not matter if the filter holder's handle is not centrally aligned with the machine. It is important that the filter holder be firmly set in its housing.
- 8 The carafe with the lid must be positioned under the filter holder so that the sprout is inside the opening on the pot's lid (fig. 8).  
Make sure that the steam knob is closed.
- 9 Insert the plug and press the power switch. The

pressure must be released by turning the steam knob (fig. 1) that the residual steam can escape.

- To remove coffee grounds from the holder, turn up-side-down repeatedly until all grounds are removed (fig. 11), or rinse the group under running water.

**NOTE** To eliminate the "new time you use the coffee machine" number of coffee cycles without

## MAKING CAPPUCCINO

A cappuccino is an espresso coffee topped with milk.

- 1 Using the table following a the required amount of milk the best results will be achieved not boiled or warm.
- 2 Transfer the milk into a jug. be large enough to allow the to around treble its volume.
- 3 Then follow steps 1-9 in the Espresso Coffee".  
**Note** that the amount of v make 2 cups of cappuccino that required for 2 cups of r it also necessary to produce emulsify the milk.
- 4 When the coffee starts to dr holder, place the steam no (fig. 12) ensuring that the n just under the surface of the in fig. 13 and open the s turning the steam knob count
- 5 Move the jug up and down nozzle fig. 14 (this will give When sufficient milk fr

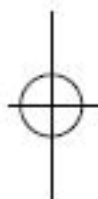

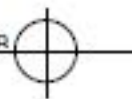

**released by slowly turning the steam knob so that the residual steam can escape.**

- 7 Pour the coffee into cups, gently pour, or preferably spoon the frothy milk onto the coffee, then sprinkle on a little chocolate powder for perfect cappuccino coffee.
- 8 Clear the steam tube (with the cappuccino nozzle) of milk immediately after use, as dried milk can be difficult to remove.

**Remember: You do this by turning the steam knob counter clockwise.**

Take care as the steam tube may be hot:

- unscrew the cappuccino nozzle by turning gently to the left (fig. 15) and wash it carefully in hot water.
- clean the steam tube and replace the cappuccino nozzle.  
(from time to time, use a pin to clean the holes in the cappuccino nozzle (fig. 16).

## HINTS

Making good espresso and cappuccino is not difficult however it does require practice. The following tips will help you get the best results from your machine:

- Warm the cups before filling with coffee.
- Use a dedicated espresso coffee for best results they are now widely available from supermarkets.
- Freshly ground coffee provides the best flavour. To maintain flavour, fresh coffee is best stored in an airtight container in a cool place, even in the fridge.

## CLEANING AND MAINTENANCE

- Before carrying out any cleaning or maintenance operations, switch the machine off, remove the plug from the socket and leave the machine to cool.

an electrical appliance.

- Never wash components or the machine in a dishwasher.







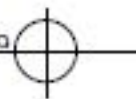

## DESCALING

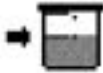
If you live in a hard-water area, the calcium found in the water will affect the operation of the machine. Approximately every six months (depending on the hardness of the water), your machine should be cleaned with vinegar and water.

1. Before cleaning your Espresso machine, switch to OFF and remove the plug from the wall socket.
2. Fill the carafe with vinegar and water.
3. Replace the boiler cap.
4. Fit the filter and filter-holder (with the filter) into the carafe.
5. Place the carafe on the drip tray.
6. Insert the plug into the wall socket.
7. Turn the switch to ON. After a few minutes the hot vinegar will begin to flow through the filter-holder into the carafe.
8. Place the steam tube in a glass and turn the steam knob for a few seconds. The hot vinegar flows through the filter-holder and will clear any milk residue from the tube.
9. Close the steam knob (the hot vinegar will continue to flow into the carafe).
10. When no more vinegar flows, turn the switch to OFF and allow the machine to cool. Remove the filter-holder from the carafe and rinse with hot water.
12. Repeat the last two steps using water in order to remove any residual vinegar.





To make	Water quantity in the carafe	Coffee quantity in the filter	Milk quantity
2 ESPRESSO'S			
2 CAPPUCCINO'S	WATER LEVEL MUST COINCIDE WITH STEAM SYMBOL ON THE CARAFE 		
4 ESPRESSO'S			
4 CAPPUCCINO'S	WATER LEVEL MUST COINCIDE WITH BOTTOM PART OF METAL BAND. 		

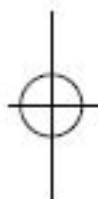



## Limited Warranty

**What Does This Warranty Cover?** We warrant each Espresso Coffee Machine to be free from defects in material and workmanship. Our obligation under this warranty is limited to replacement or repair, without charge at our factory or authorized service centers, of any defective part or parts there of other than those damaged in transit, which shall be returned to us, transportation prepaid. This warranty shall apply only if the Espresso Coffee Machine is used in accordance with the factory directions which accompany it.

**How Long Does The Coverage Last?** This warranty runs for one year from the date of delivery. The warranty applies only to the original purchaser.

**What Does This Warranty Not Cover?** This warranty does not cover defects or damage to the Espresso Coffee Machine which result from repairs or alterations to the machine outside our factory or authorized service centers, nor shall it apply to any Espresso Coffee Machine which has been subjected to abuse, misuse, negligence or accidents. Also, consequential and incidental damages resulting from the use of this product or arising out of any breach of contract or breach of this warranty are not recoverable under this warranty. Some states do not allow the exclusion or limitation of incidental or consequential damages, so the above limitation may not apply to you.

**How Do You Get Service?** If repairs become necessary or spare parts are needed, please write to:

De'Longhi America Inc.  
Park 80 West Plaza One-4th Floor  
Saddle Brook, NJ 07663