

COFFEE MACHINE

Owner's instructions

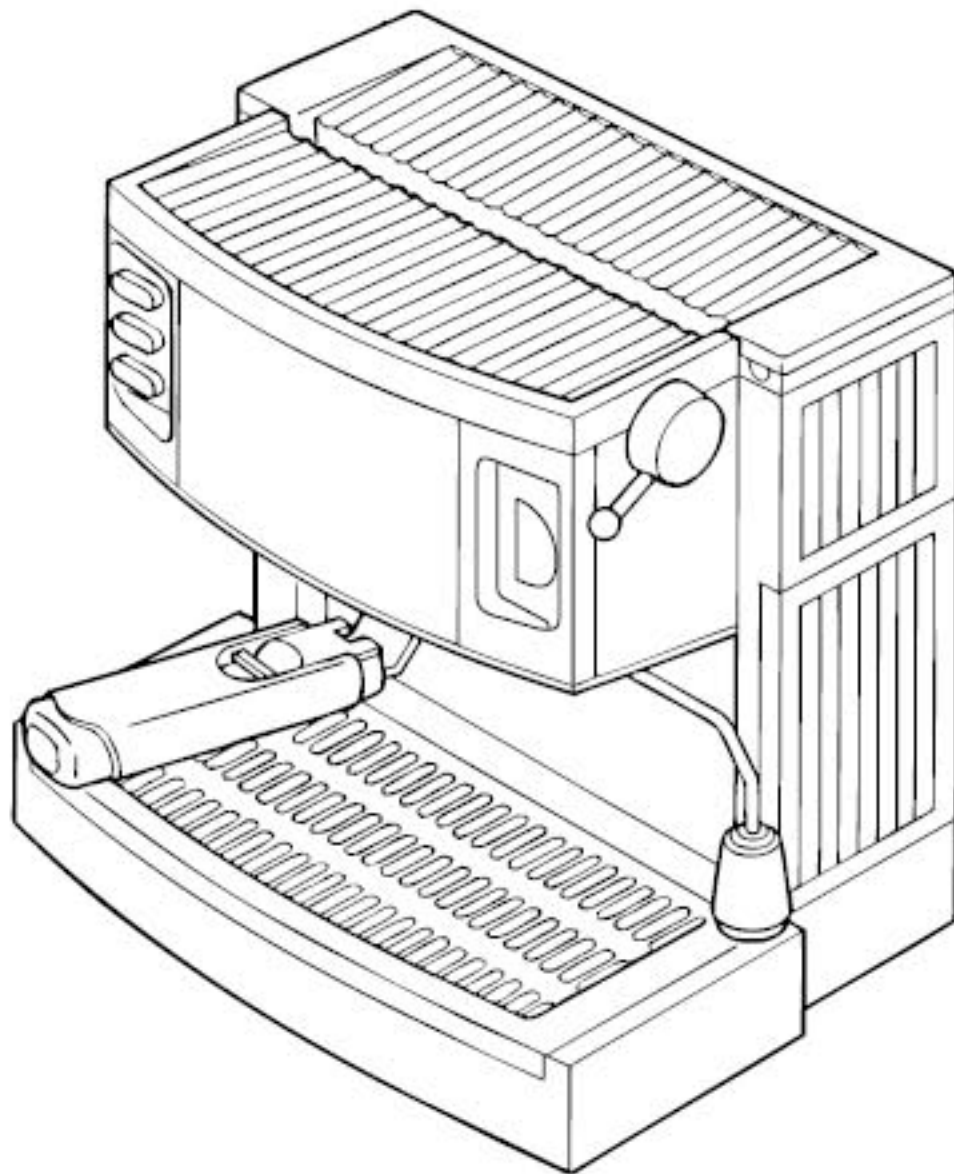

READ AND SAVE THESE INSTRUCTIONS

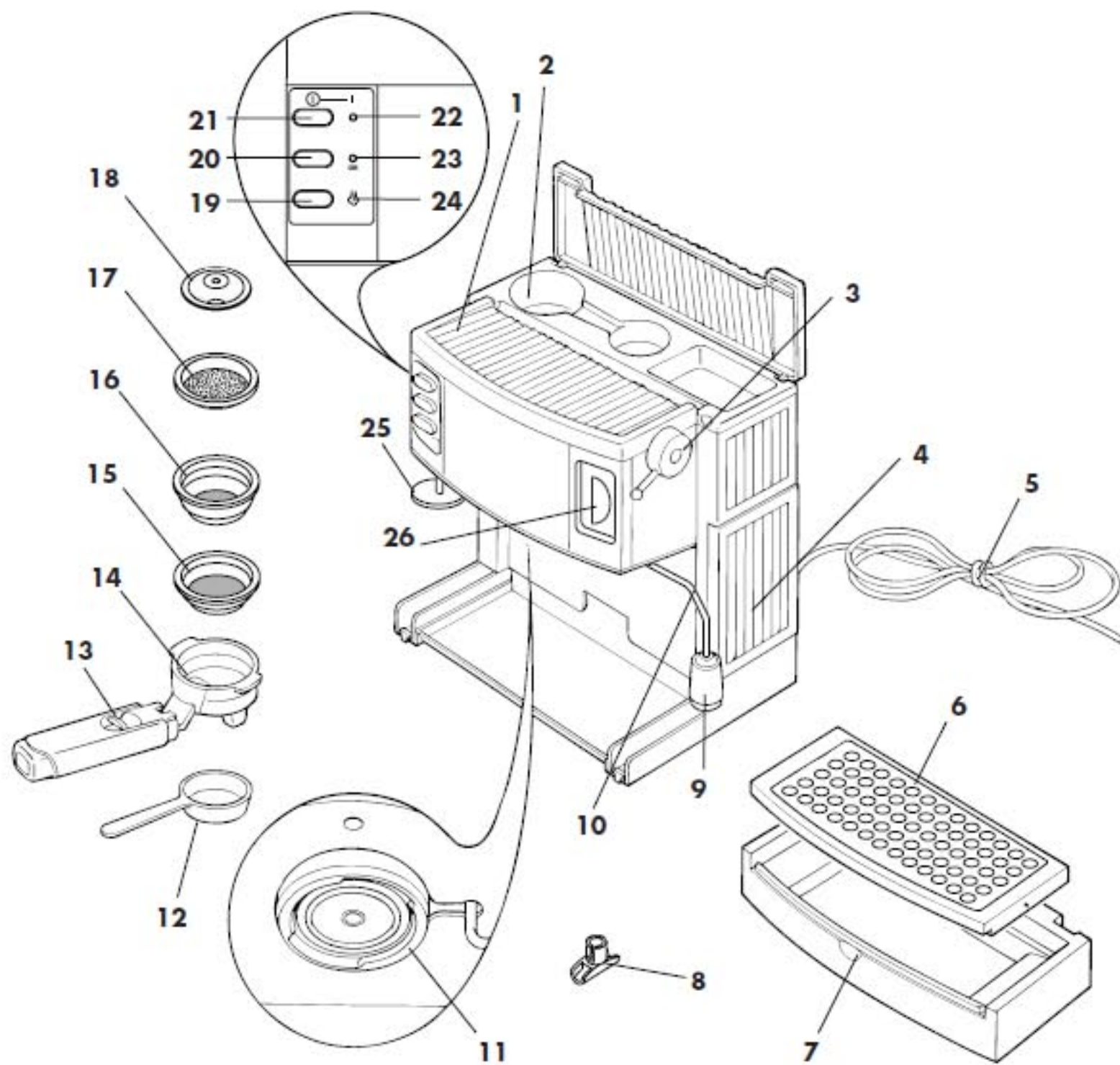

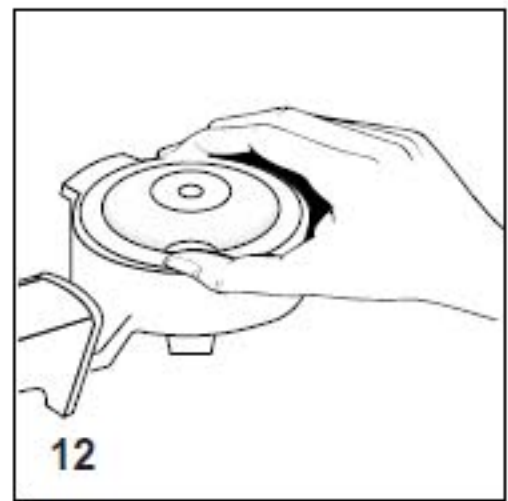
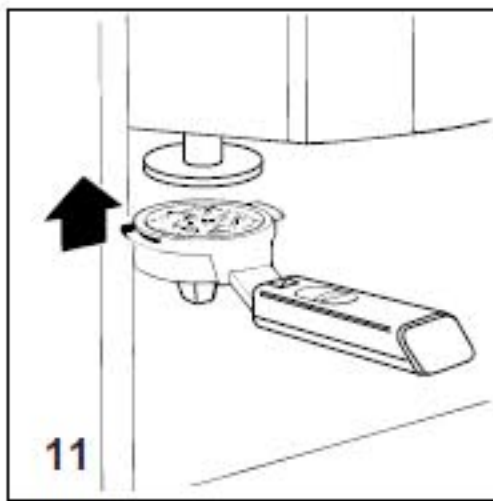
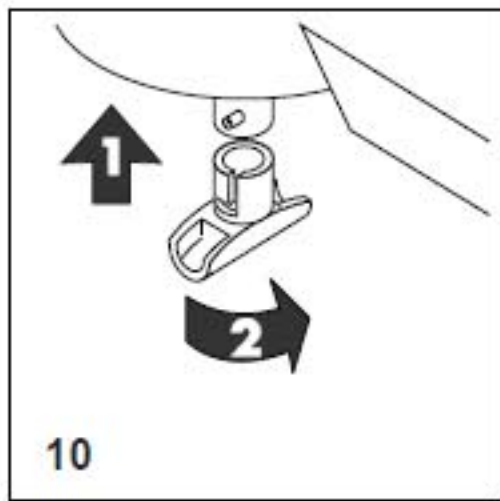
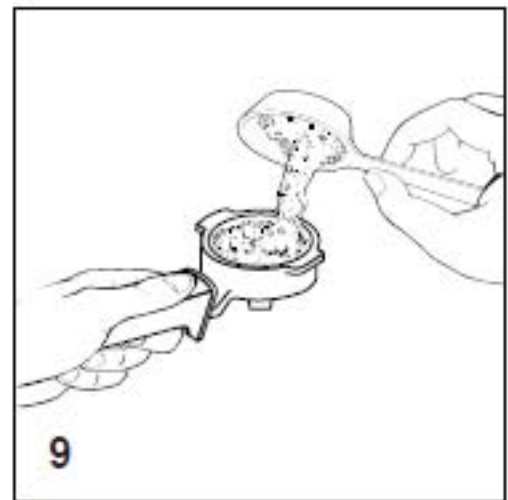
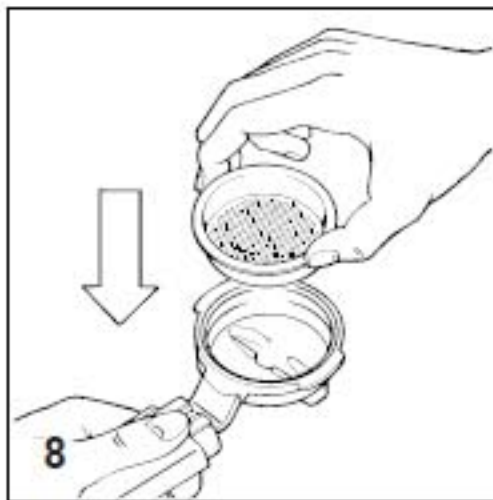
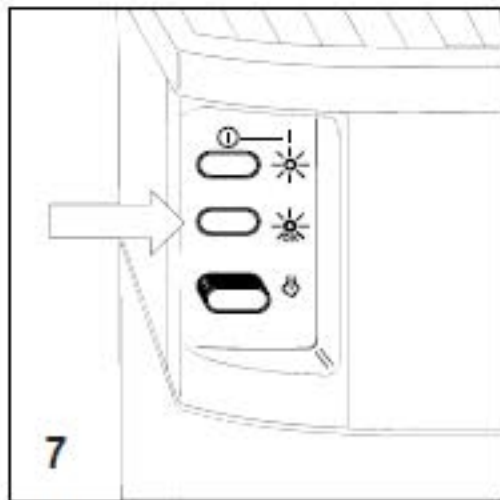
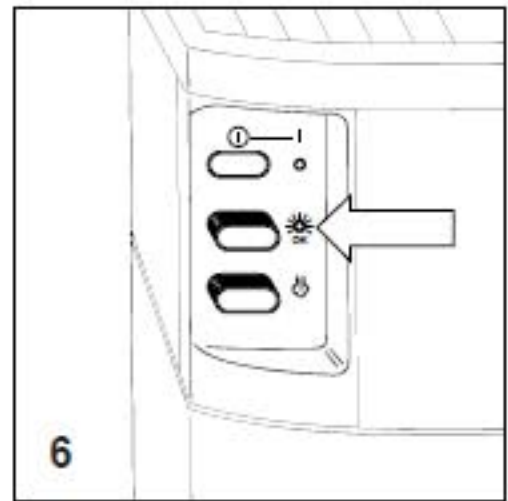
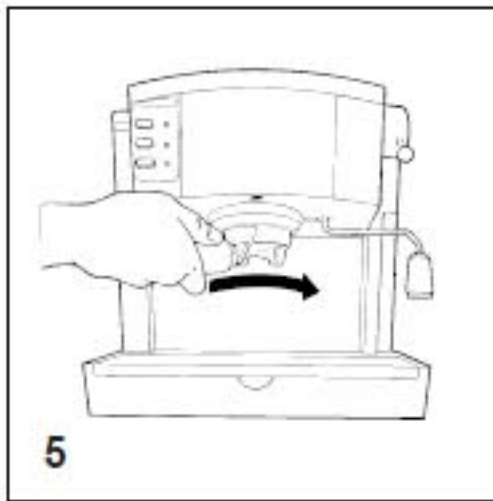
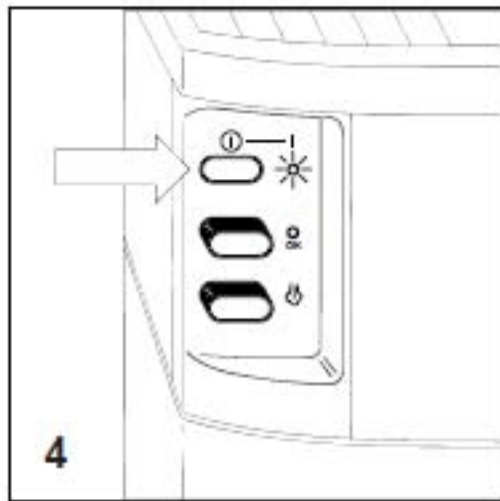
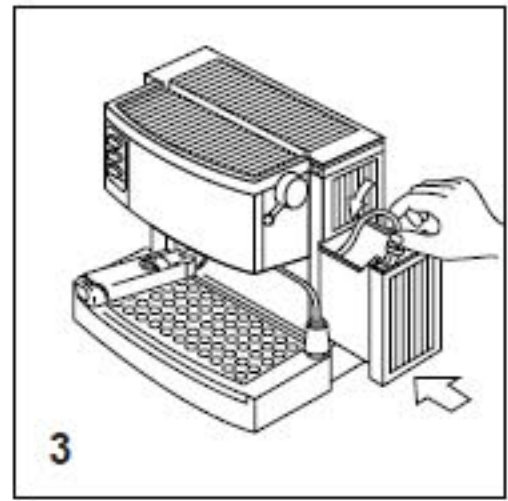
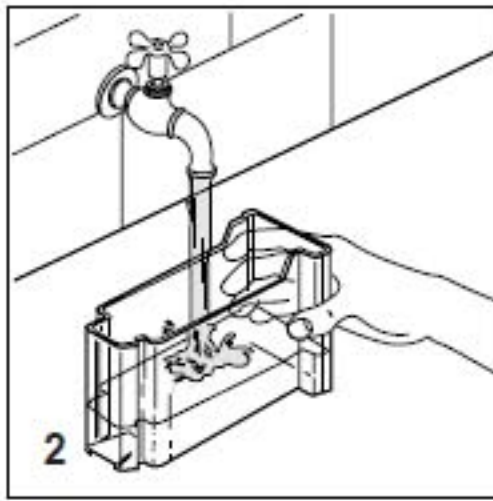
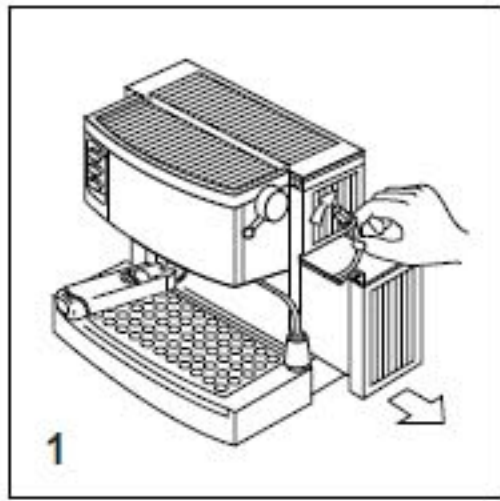

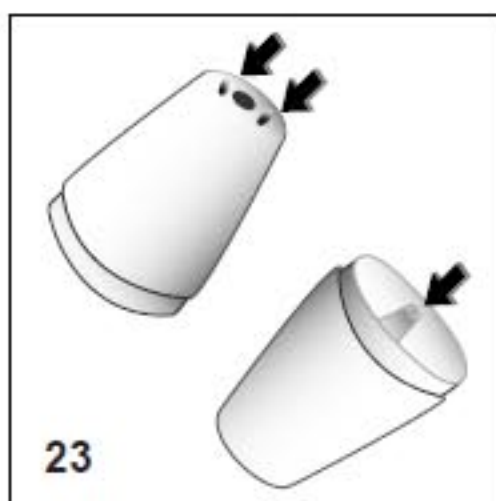
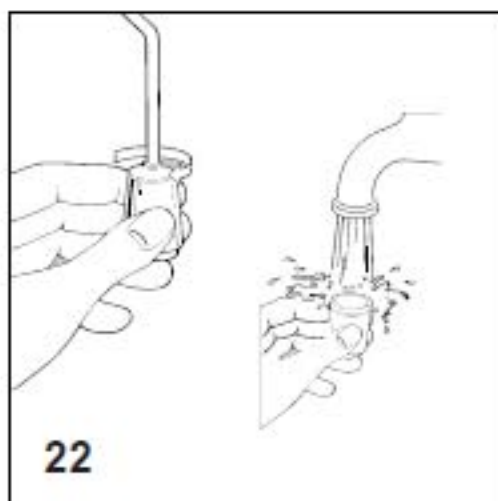
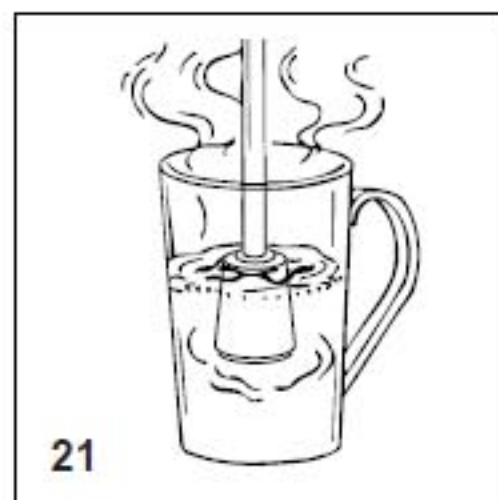
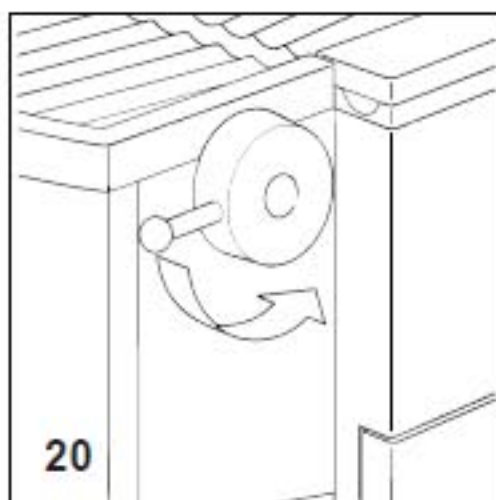
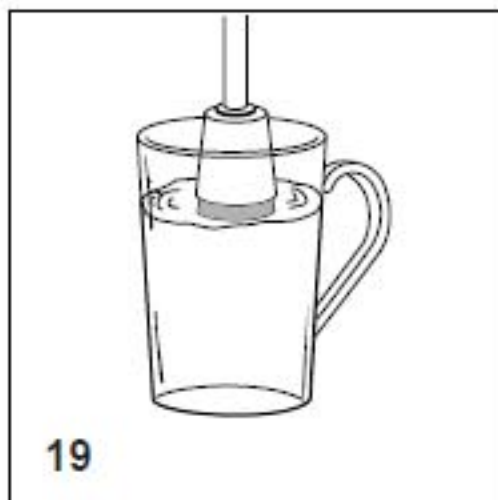
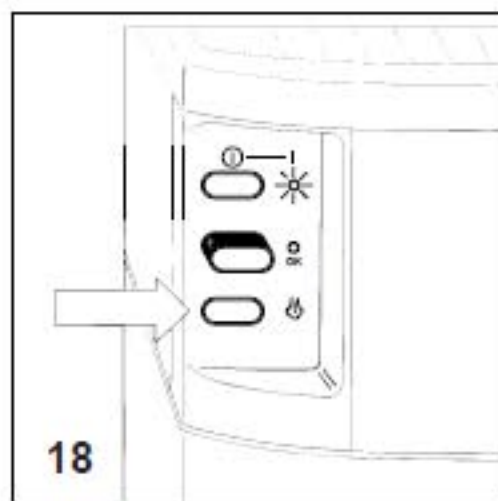
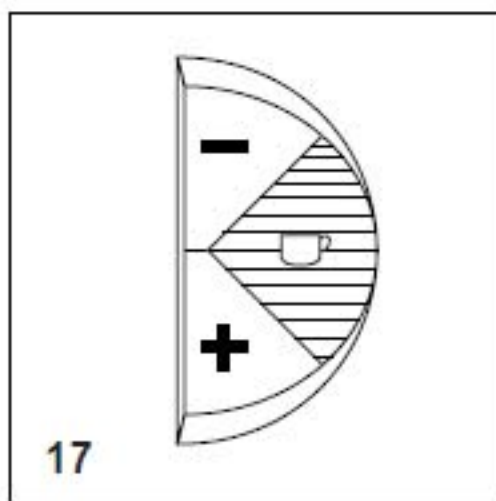
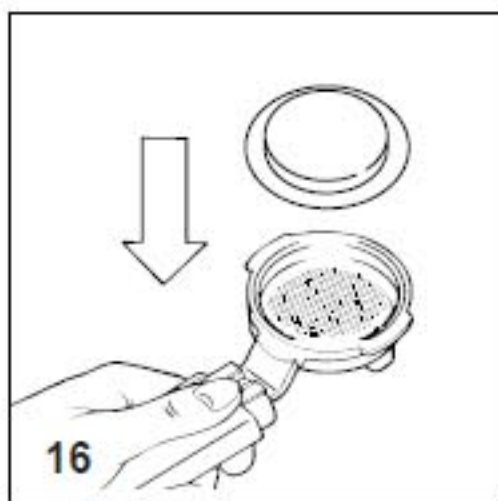
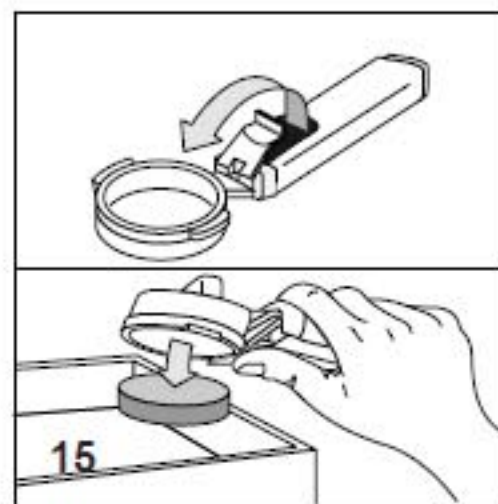
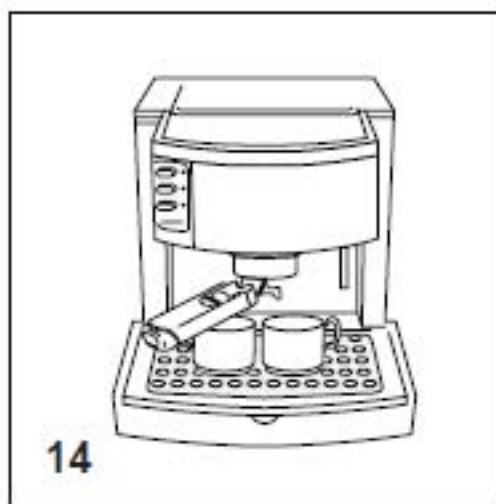
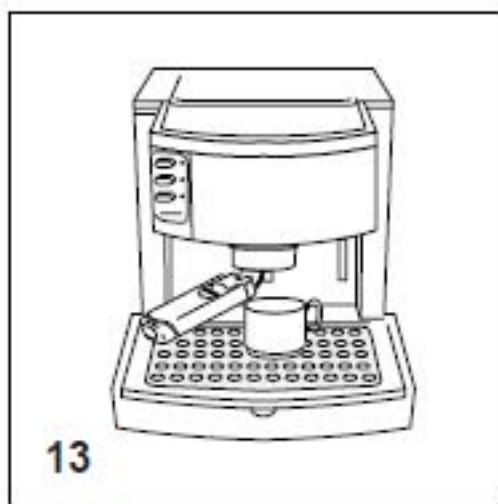



IMPORTANT SAFEGUARDS

When using electrical appliances, basic safety precautions should always be followed, including the following:

- Read all instructions.
- Do not touch hot surfaces. Use handles and knobs.
- To protect against fire, electrical shock and personal injury, do not immerse cord, plug or appliance in water or other liquid.
- Close supervision is necessary when any appliance is used by or near children.
- Unplug from the outlet when not in use and before cleaning. Allow to cool before fitting or taking off parts, and before cleaning the appliance.
- Do not operate with a damaged cord or plug, or after the appliance malfunctions, or has been damaged in any manner. Return the appliance to the nearest authorized service facility for examination, repair or adjustment.
- The use of accessory attachments or spare parts not recommended by the appliance manufacturer may result in fire, electrical shock or personal injury.
- Do not use outdoors.
- Do not let the cord hang over the edge of the table or counter, or touch hot surfaces.
- Do not place on or near a hot gas or electrical burner, or in a heated oven.
- Plug cord into the wall outlet. To disconnect, turn any control to "off", then remove plug from wall outlet.
- Do not use the appliance for other than the intended use.
- DO NOT unscrew or remove boiler cap while the machine is in operation. Wait until brewing cycle is completed and all water and steam has been used up.
- Appliances with Glass Containers:
 - A. The container is designed for use with this appliance. It must never be used on a range top.
 - B. Do not set a hot container on a wet or cold surface.
 - C. Do not use a cracked container or a container having a loose or weakened handle.
 - D. Do not clean container with cleansers, steel wool pads, or other abrasive material.

SAVE THESE INSTRUCTIONS

SHORT CORD INSTRUCTIONS

- A short power cord is provided to reduce risks resulting from becoming entangled in or tripping over a longer cord.
- Longer, detachable power supply cords or extension cords are available and may be used if care is exercised in their use.
- If an extension cord is used, the marked electrical rating should be at least as great as the electrical rating of the appliance. If the appliance is provided with 3-wire, grounding type cord, the extension should be a GROUNDING TYPE 3 - WIRE CORD. The longer cord should be arranged so that it will not drape over the counter-top or table top where it can be pulled on by children or tripped over.
- Your product is equipped with a polarized alternating current line plug (a plug having one blade wider than the other). This plug will fit into the power outlet only one way. This is a safety feature. If you are unable to insert the plug fully into the outlet, try reversing the plug. If the plug should still fail to fit, contact your electrician to replace your obsolete outlet. Do not defeat the safety purpose of the polarized plug.

Read this instruction booklet carefully before installing and using the machine. In this way, you will obtain the best possible results and maximum operating safety.

DESCRIPTION OF THE APPLIANCE

The following terms are used throughout the instructions manual.

1. Cup stand
2. Accessories holder
3. Steam control knob
4. Water tank
5. Power cord
6. Cup holder grill
7. Drip tray
8. 2-cup adaptor
9. "Cappuccino" nozzle
10. Steam and hot water nozzle
11. Boiler outlet
12. Measuring spoon
13. Filter thumb guard
14. Filter holder
15. 1-cup filter
16. 2-cup filter
17. Pod filter
18. Automatic coffee press
19. Steam switch
20. Coffee dispenser switch
21. ON/OFF switch (①)
22. ON/OFF indicator light (①)
23. "OK" indicator light
24. Steam indicator light
25. Coffee press
26. Pressure gauge (if fitted)

INSTALLATION

- Place the appliance on a flat work surface away from water sources such as taps or sinks.
- Check that the voltage of the electrical power line corresponds to the voltage indicated on the appliance label. Connect the appliance only to a power source having a minimum load capacity of 10 amps and having a proper grounding feature. The manufacturer takes no responsibility for any accidents caused by the lack of a grounding device for the appliance.
- In case of incompatibility between the plug and

your socket, have the socket replaced by a qualified electrician. The supply cable must not be replaced by the user, as this requires the use of special tools. If the supply cable is damaged, contact an authorized Service Centre.

- Never install the machine in an environment which can reach a temperature of less than or equal to 0°C (if the water inside the machine freezes, the machine might be damaged):

FILLING THE TANK

Remove the reservoir by pulling it sideways, at the same time lifting the tubes (fig. 1).

Rinse the reservoir and fill with fresh water (fig. 2). Replace the reservoir in its housing, ensuring that the tubes are immersed in the water (fig. 3). A simpler way of filling the reservoir is to pull it out just enough to be able to pour in water directly from a jug. Never start up the appliance without water in the tank.

PRE-HEATING OF THE MACHINE

In order to obtain a coffee at the right temperature, it is necessary to pre-heat the machine by keeping it on by pushing the ON/OFF switch (fig.4), for at least a half-hour before making coffee. During this time, **it is necessary to leave the filter holder attached to the boiler.** To attach the filter holder, position it under the boiler shower with the handle towards the left - see fig. 5; push upwards and at the same time rotate the handle towards the right; always rotate as far as it will go).

After a half-hour the coffee can then be made as described below.

To speed up this operation, it is also possible:

- 1 To turn the machine on by pushing the ON/OFF switch (fig.4).
2. To insert the filter holder in the boiler without coffee or coffee pod. Place a coffee cup beneath the filter holder.
3. To wait until the light "OK" turns on (fig. 6) and press the delivery switch (fig.7), letting the water exit until the "OK" light goes off; then stop the dispensing by pressing the coffee dispenser switch.
4. Then empty the water from the cup, wait until the "OK" light turns back on and repeat the same operation again.

HOW TO OPERATE WITH GROUND COFFEE

1. After having carried out the pre-heating of the machine, as described in the previous section, insert the 1-cup filter (the medium-sized one of the three provided) in the filter holder (fig. 8) and fill it up with 1 even measuring spoon of ground coffee – about 7 grams (fig. 9). If you need to prepare 2 cups, use the 2-cup filter (the largest of the three filters provided), fill it with two less-than-even measuring spoons of ground coffee (about 6+6 grams) and attach the 2-cup adaptor.

In order to attach the adaptor to the filter holder, insert it into the spout, push the adaptor up and turn it (see fig. 10).

2. Spread the coffee evenly and press by using the tamper (fig. 11). **NOTE:** pressing the ground coffee is very important in order to obtain a good espresso coffee. If you press too hard, the coffee comes out slowly and the cream is dark in colour. If, on the other hand, the coffee is not pressed enough, it will come out too quickly and the cream will be light in colour.
3. Remove any excess of coffee from the filter rim, put the automatic coffee press on the ground coffee (fig. 12) and attach the filter holder (remembering to rotate it, as far as it will go).
4. Place the pre-warmed cup or cups on the drip tray under the filterholder spout (fig. 13 or 14).
5. When the "OK" pilot lamp lights (fig. 6), press the delivery switch. When the desired quantity of coffee is obtained, turn the delivery switch (fig.7) off.
6. Wait a few seconds before detaching the filter holder by turning the handle from right to left. **ATTENTION: to avoid squirts, never detach the filter holder while the machine is dispensing.**
7. To remove the used coffee grounds retain the filter in position using the thumb guard fitted to the handle; turn the filter-holder upside down and knock the coffee grounds out (fig. 15).
8. Switch off the machine by pushing the ON/OFF switch (fig. 4).

HOW TO OPERATE WITH PODS

1. Carry out the pre-heating of the machine as described in the "PRE-HEATING OF THE MACHINE" section.
Insert the pod filter (the smallest of the three filters provided) in the filter holder.
2. Insert the pod in the pod filter (fig. 16).
3. Attach the filter holder, remembering to rotate it, as far as it will go.
4. Place the pre-warmed cup on the drip tray under the filter holder spout (fig. 13) and proceed as described in points 5 and 8 of the previous section.

ATTENTION: The first time that coffee is prepared, it is necessary to wash all of the accessories and the internal circuits allowing at least a half litre of hot water to flow through, as described below in the PRODUCING HOT WATER section.

USING THE PRESSURE GAUGE (if fitted)

In order to obtain a good espresso coffee, it is necessary that the delivery take place with the boiler at its optimum pressure. This pressure is attained when the pointer of the pressure gauge is within the grey-coloured section (fig. 17).

HOW TO PREPARE CAPPUCCINO

1. Prepare one or two espresso coffee, using 2 sufficiently large cups
2. Press the steam switch (fig. 18) and wait until the "OK" light (fig. 6) turns on, meaning the boiler has reached the ideal temperature for producing steam.
3. Pour approximately 100 grams of milk into the container for each cappuccino to be made. It is important to use fresh milk which has not been boiled (not UHT) and especially not preheated. When choosing the container to use for the milk, keep in mind that the frothed milk will increase by two or three times its original volume.
4. Place the recipient under the cappuccino maker.
5. Immerse the frother into the milk by about 5 mm (fig. 19) and turn the steam release knob in a counter clockwise direction, fig. 20 (by turning the knob more or less, it is possible to vary the

amount of steam which will come out of the frother tube). At this point, the milk should begin to increase in volume and assume a dense and creamy texture.

6. When the volume of milk has doubled, immerse the frother deeper into the milk to continue to froth and heat the milk (fig. 21).

Once the desired temperature has been reached (the optimum temperature is 60°C), in order to interrupt the release of steam, turn the handle in a clockwise direction and press the steam switch, as indicated in figure 18.

7. Pour the frothed milk over the coffee, with the aid of a spoon. Then, as a final touch, sprinkle a bit of cocoa powder over the frothy milk to have a perfect cappuccino.

IMPORTANT: The milk frother for cappuccinos must be thoroughly cleaned after each use. Proceed as follows:

1. Release the steam for few seconds by opening the steam control knob (fig. 20).
- Unscrew the milk frothing bit from the tube by turning in a clockwise direction (fig. 22) and wash it carefully with warm water.
 - Make sure that the three holes of the milk frother, illustrated in fig. 23, are not plugged. If necessary, clean the holes with a pin or needle and soaking the frother bit in warm water.
 - Clean the steam release tube carefully so as to not get burned.
 - Screw the milk frothing bit back into place.

PRODUCING HOT WATER

1. Press the ON/OFF switch (fig. 4) and wait until the "OK" pilot lamp lights (fig. 6).
2. Place a cup or glass under the steam nozzle.
3. Press the delivery switch (fig.7) and, at the same time, open the steam control knob (fig. 19). Hot water will flow from the nozzle.
4. As soon as the desired quantity of hot water has been obtained, close the knob and turn the delivery switch off.

CLEANING AND MAINTENANCE

1. To clean the machine, do not use solvents or abrasive detergents. A soft damp cloth should be used to clean the surfaces.
2. Clean the filter holder, drip tray, boiler and water tank regularly.
3. Check from time to time that the 3 filters for espresso coffee are not obstructed. If necessary, carefully clean the filter with hot water, scrubbing with an abrasive pad.

LIME REMOVAL

It is advisable to de-scale the **espresso coffee machine** every 4 to 8 months (depending on the hardness of the water and the frequency of use) using white wine vinegar.

Proceed as follows:

1. Fill the water reservoir with water and add 8 large spoonfuls of vinegar.
2. Operate the appliance, as if making coffee, until the tank is empty, then rinse thoroughly. Sometimes open the steam tap.
3. Repeat this procedure 2 - 3 times with fresh water only in order to remove any residual de-scaling agent.

PROBLEM	PROBABLE CAUSES	RESOLUTION
Espresso coffee no longer drips out	No water in the tank; The hole in the spout of the filter holder is plugged; The filter is obstructed;	Fill the water tank Clean the hole in the filter holder; Clean the filter with hot water, scrubbing with an abrasive pad;
The espresso coffee drips from the rim of the filter holder instead of from the holes	The filter holder is not inserted correctly; The hole in the filter holder spout is blocked; The filter is obstructed	Attach the filter holder correctly and rotate it as far as it will go; Clean the hole in the spout; Clean the filter with hot water, scrubbing with an abrasive pad;
The espresso coffee is cold	The espresso coffee is cold. The "OK" light for the temperature is not turned on when preparing the espresso coffee; The pre-heating phase is not carried out; The cups are not pre-heated;	Wait until the "OK" light comes on; Carry out the pre-heating as described in the "PRE-HEATING OF THE MACHINE" section; Pre-heat the cups;
The pump is making too much noise	The water tank is empty; Suction tube not immersed in the water;	Fill the tank; Immerse the suction tube in the tank water;
The milk froth does not form properly when making cappuccinos	The milk is not cold enough; The milk frother bit is dirty	Always use milk cold from the refrigerator; Carefully clean the holes of the milk frother;



Limited Warranty

What Does This Warranty Cover? We warrant each Espresso Coffee Machine to be free from defects in material and workmanship. Our obligation under this warranty is limited to replacement or repair, free of charge at our factory or authorized service centers, of any defective part or parts there of other than parts damaged in transit, which shall be returned to us, transportation prepaid. This warranty shall apply only if the Espresso Coffee Machine is used in accordance with the factory directions which accompany it.

How Long Does The Coverage Last? This warranty runs for one year from the date of delivery and applies only to the original purchaser.

What Does This Warranty Not Cover? This warranty does not cover defects or damage of the Espresso Coffee Machine which result from repairs or alterations to the machine outside our factory or authorized service centers, nor shall it apply to any Espresso Coffee Machine which has been subject to abuse, misuse, negligence or accidents. Also, consequential and incidental damages resulting from the use of this product or arising out of any breach of contract or breach of this warranty are not recoverable under this warranty. Some states do not allow the exclusion or limitation of incidental or consequential damages, so the above limitation may not apply to you.

How Do You Get Service? If repairs become necessary or spare parts are needed, please write to:

De'Longhi America Inc.
Park 80 West Plaza One, 4th floor
Saddle Brook NJ 07663
or call Service Tel. No 1-800-322-3848
or visit our internet site:
www.delonghiusa.com

The above warranty is in lieu of all other express warranties and representations; All implied warranties are limited to the applicable warranty period set forth above. This limitation does apply if you enter into an extended warranty with De'Longhi. Some states do not allow limitations on how long an implied warranty lasts, so the above exclusions connection with the sale or use of its Espresso Coffee Machine.

How Does State Law Apply? This warranty gives you specific legal rights, and you may also have other rights which vary from state to state.



GARANTIE

Nous garantissons que tous les APPAREILS ELECTRIQUES DE' LONGHI sont exempts de tout défaut de matériaux et de manufacture. Notre obligation sous cette garantie est limitée au remplacement ou à la réparation gratuite dans notre usine de toutes les pièces défectueuses autre que les pièces endommagées durant le transport, qui nous seront retournées - transport pré-payé - en dedans d'un an après la livraison à l'acheteur - utilisateur. Cette garantie ne sera applicable que si l'appareil a été utilisé selon les instructions du fabricant qui accompagnent l'appareil, et sur courant alternatif (AC). Cette garantie remplace toutes les autres garanties et représentations, exprimées ou impliquées, et toute autre obligation ou responsabilité de notre part. Nous n'autorisons aucune autre personne ou compagnie à assumer pour nous une quelconque responsabilité en relation avec la vente ou l'utilisation de nos appareils.

Cette garantie ne s'appliquera ni aux appareils qui seront réparés ou endommagés hors de notre usine, ni aux appareils qui auront été sujets à une mauvaise utilisation, à une négligence ou à un accident.

Si des réparations ou des pièces de rechange sont nécessaires, vous êtes priés d'écrire à:

De'Longhi America Inc.
Park 80 West Plaza One, 4th floor
Saddle Brook NJ 07663
Tel. No 1-800-322-3848
ou bien contacter notre site Internet:
www.delonghiusa.com