

This Owner's Manual is provided and hosted by [Appliance Factory Parts](#).



DE'LONGHI EC330 Owner's Manual

[Shop genuine replacement parts for DE'LONGHI EC330](#)



[Find Your DE'LONGHI Coffee Maker Parts - Select From 289 Models](#)

----- Manual continues below -----

IMPORTANT INSTRUCTIONS SAVE THESE INSTRUCTIONS

COFFEE MAKER TYPE EC330/

ELECTRONIC CHARACTERISTICS:

120V-60HZ - 1100W



Register this product on-line and receive a free trial issue of Cook's Illustrated. Visit www.delonghiregistration.com. Visit www.delonghi.com for a list of service centers near you. (U.S. and Canada)

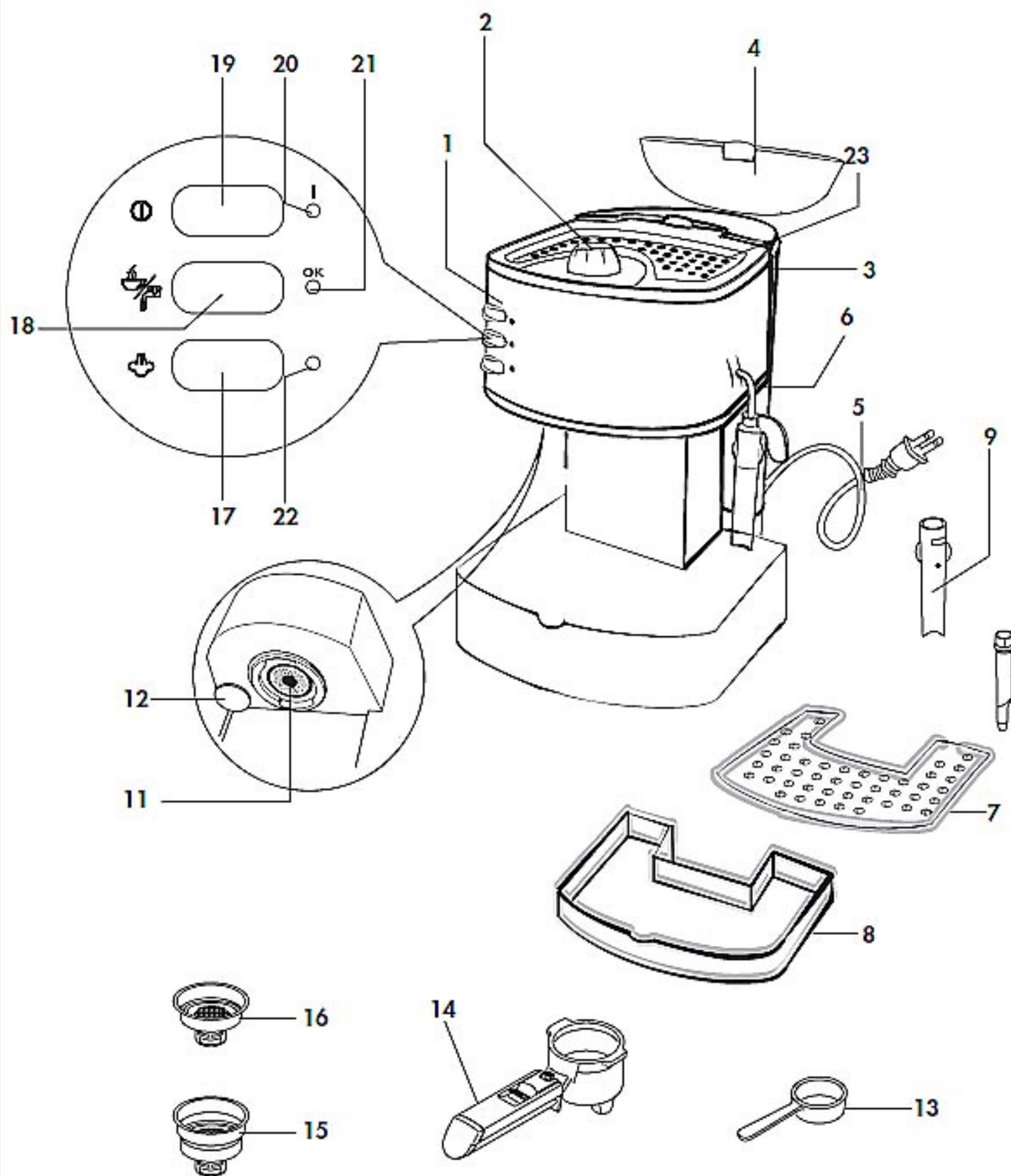

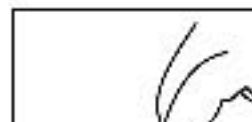
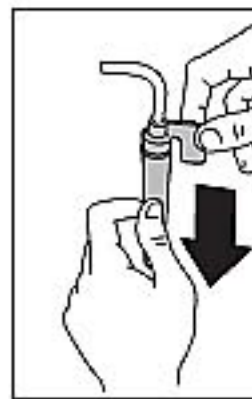
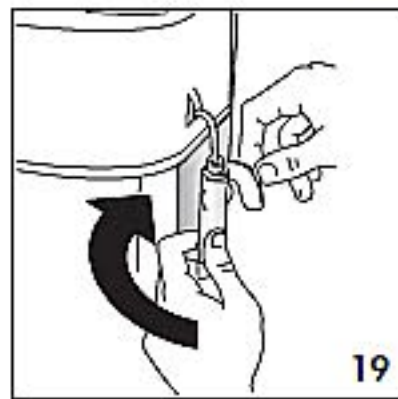
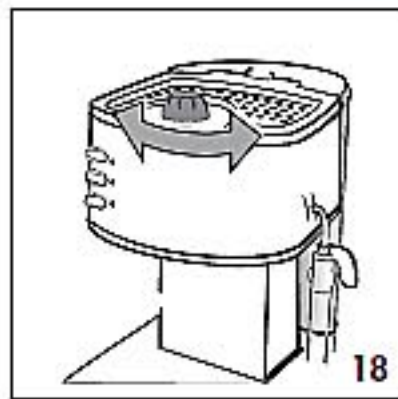
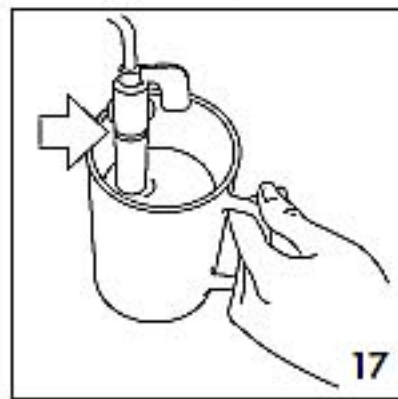
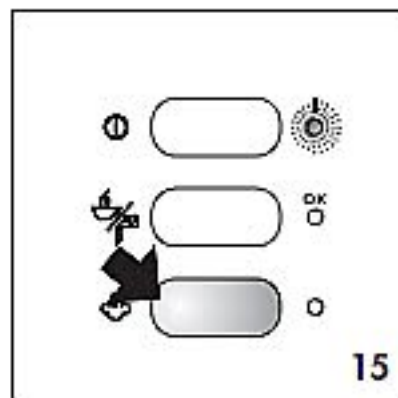
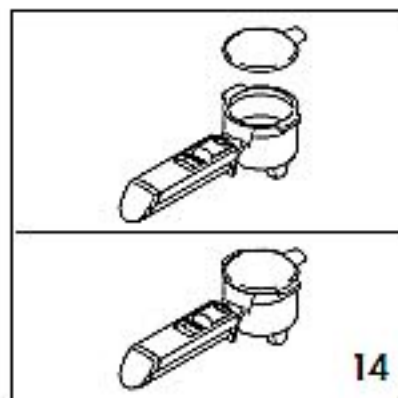
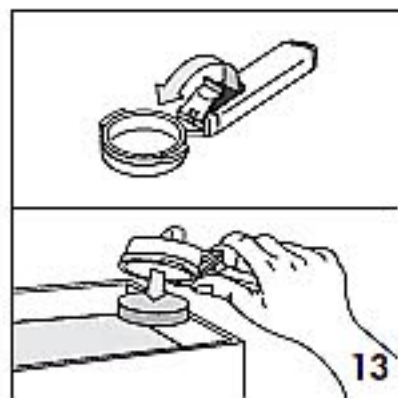
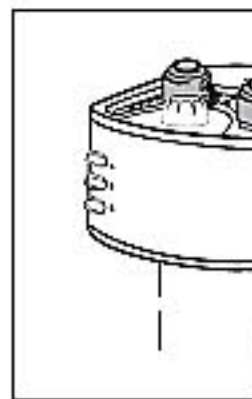
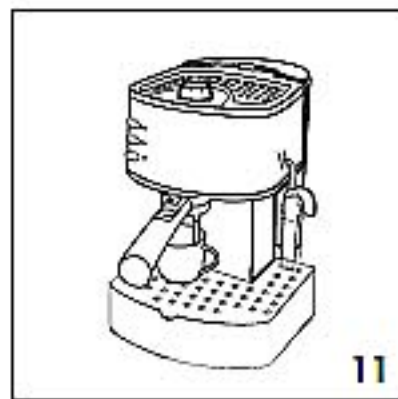
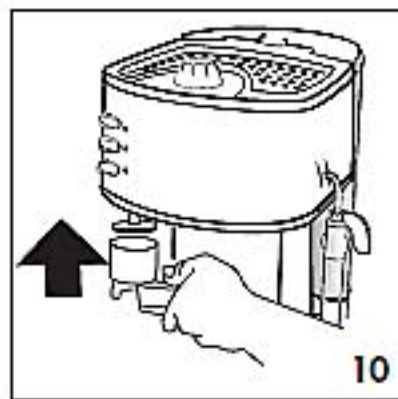
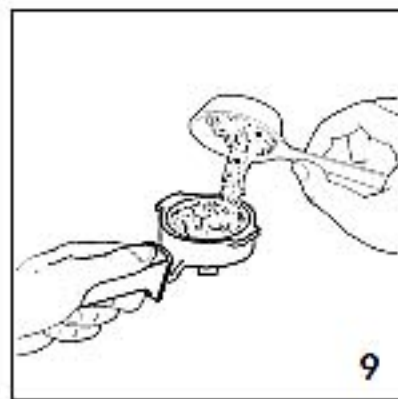
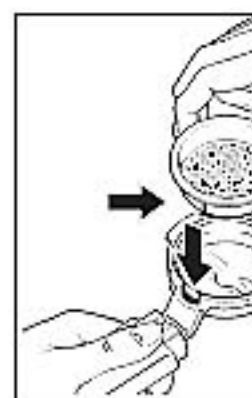
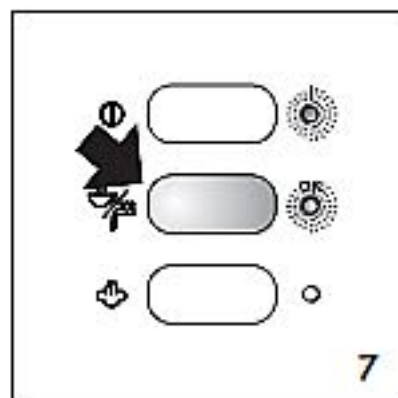
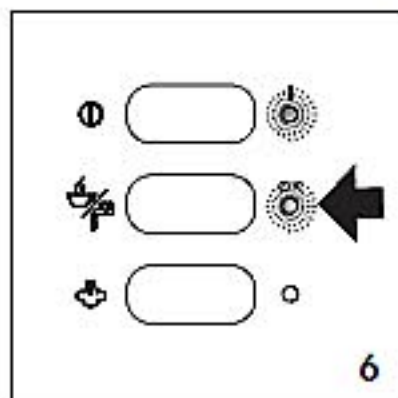
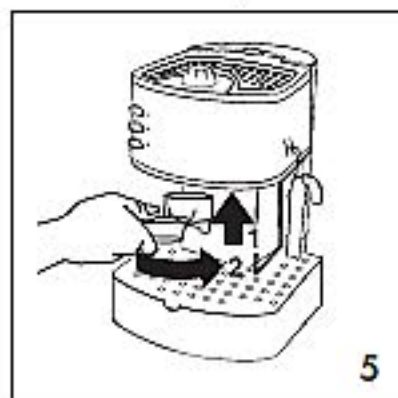
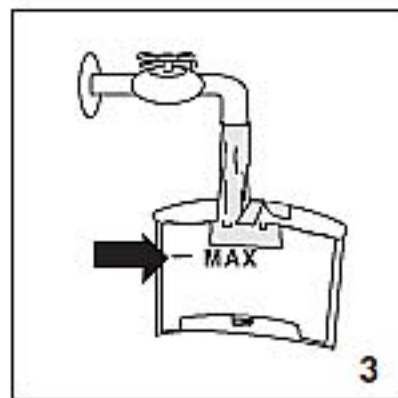
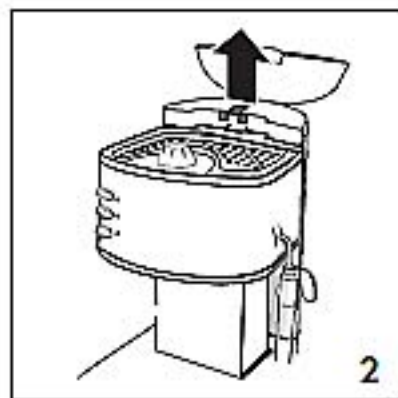

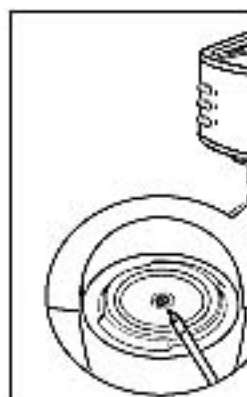
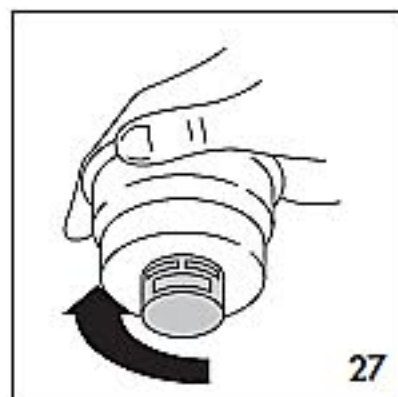
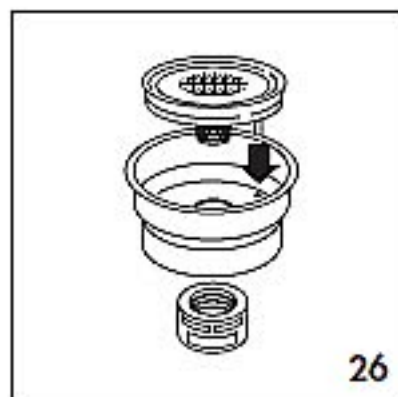
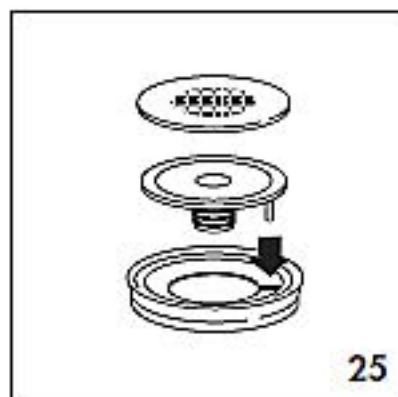

IMPORTANT SAFEGUARDS

When using electrical appliances, basic safety precautions should always be followed, including the following:

- Read all instructions.
- Do not touch hot surfaces. Use handles and knobs.
- To protect against fire, electrical shock and personal injury, do not immerse cord, plug or appliance in water or other liquid.
- Never allow the appliance to be used by children.
- Unplug from the outlet when not in use and before cleaning. Allow to cool before fitting or taking parts, and before cleaning the appliance.
- Do not operate with a damaged cord or plug, or after the appliance malfunctions, or has been damaged in any manner. Return the appliance to the nearest authorized service facility for examination, repair or adjustment.
- The use of accessory attachments or spare parts not recommended by the appliance manufacturer may result in fire, electrical shock or personal injury.
- Do not use outdoors.
- Do not let the cord hang over the edge of the table or counter, or touch hot surfaces.
- Do not place on or near a hot gas or electrical burner, or in a heated oven.
- Plug cord into the wall outlet. To disconnect, turn any control to "off", then remove plug from wall outlet.
- Do not use the appliance for other than the intended use. This appliance is to be utilized for domestic use only. Any other use is to be considered improper and therefore, dangerous.

WARNING: To reduce the risk of fire or electric shock, do not remove the cover.

No user serviceable parts inside. Repair should be done by authorized service personnel only!

SAVE THESE INSTRUCTIONS
THIS PRODUCT IS FOR HOUSEHOLD USE ONLY

SHORT CORD INSTRUCTIONS

- A short power cord is provided to reduce risks resulting from becoming entangled in or tripping over a longer cord.
- Longer, detachable power supply cords or extension cords are available and may be used if care is exercised in their use.
- If an extension cord is used, the marked electrical rating should be at least as great as the electrical rating of the appliance. If the appliance is provided with 3-wire, grounding type cord, the extension should be a GROUNDING TYPE 3 - WIRE CORD. The longer cord should be arranged so that it will not drape over the counter-top or table top where it can be pulled on by children or tripped over.
- Your product is equipped with a polarized alternating current line plug (a plug having one blade wider than the other). This plug will fit into the power outlet only one way. This is a safety feature. If you are unable to insert the plug fully into the outlet, try reversing the plug. If the plug should still fail to fit, consult your electrician to replace your obsolete outlet. Do not defeat the safety purpose of the polarized plug.

Read this manual thoroughly before installing and using the appliance.

This is the only way to ensure best results and maximum safety for the user.

DESCRIPTION

(see figure on fig. 3)

The terminology below will be used repeatedly on the following pages.

1. Control panel
2. Steam knob
3. Water tank
4. Water tank lid
5. Power cable
6. Steam/hot water tube
7. Cup tray
8. Drip tray
9. Cappuccino maker
10. Nozzle
11. Boiler outlet
12. Pusher
13. Measure for ground coffee
14. Filter holder
15. Large two-cup filter
16. Small one-cup or pod filter
17. Steam selector button
18. Coffee/hot water button
19. ON/OFF button
20. ON light
21. Temperature OK light (coffee, hot water or steam)
22. STEAM indicator light
23. Cup warming plate

SAFETY WARNINGS

- This appliance is designed to make coffee or heat drinks. Be careful to avoid being scalded by sprays of water or steam or due to improper use of the appliance.
- This appliance is intended for domestic use only. Any other use is considered improper and thus dangerous.
- The manufacturer cannot be held responsible for any damage caused through incorrect, wrong or unreasonable use.
- When using the appliance, do not touch the hot surfaces. Use the knobs or handles.
- Never touch the appliance with wet or damp hands

knowledge, unless they have been given supervision or instruction concerning use of the appliance. A person responsible for their safety. Children should be supervised to ensure that they do not play with the appliance.

- In the event of failure or malfunction, unplug the appliance from the mains. For repairs, contact an authorized Service Centre only and request only spare parts. Failure to respect the above instructions may reduce the safety of the appliance.

INSTALLATION

- After removing the packaging, make sure the product is complete.
If in doubt, do not use the appliance and contact a qualified professional.
- The packing elements (plastic bags, polystyrene, etc.) should be kept out of reach of children as they are a safety hazard.
- Place the appliance on a work surface far away from water taps, basins and sources of heat.
- After positioning the appliance on the work top, leave a space of at least 5 cm between the surfaces of the appliance and the side and rear walls and at least 5 cm above the coffee maker.
- Never install the appliance in environments where the temperature may reach 0°C or lower (the appliance may be damaged if the water freezes).
- Check that the voltage of the mains power supply corresponds to the value indicated on the appliance rating plate.

Connect the appliance to an efficiently earthed power supply with a minimum current rating of 10A only.

The manufacturer may not be considered liable for possible incidents caused by the failure to adequately earth the mains.

- If the power socket does not match the plug of the appliance, have the socket replaced with a suitable one by a qualified professional.
- The power cable on this appliance must not be repaired by the user as this operation requires the use of special tools.

If the cable is damaged or requires replacing, contact an authorised service centre only to avoid all risks.

HOW TO MAKE ESPRESSO COFFEE

FILLING THE WATER TANK

1. Open the water tank lid (fig. 1) and then take out the tank by pulling upwards (fig. 2).
2. Fill the tank with fresh clean water taking care not to exceed the MAX level. (fig. 3).

Replace the tank, pressing lightly to open the valve located on the bottom of the tank.

3. More simply, the tank can also be filled without removing it, pouring the water directly from a jug.

IMPORTANT: It is normal for there to be water in the space under the tank. This should therefore be dried regularly with a clean sponge.

NB: Never use the appliance without water in the tank and always remember to top up when the level drops to a couple of centimetres from the bottom.

PREHEATING THE COFFEE UNIT

To obtain espresso coffee at the right temperature, the coffee machine must be preheated. Press the ON/Off button ① (fig. 4) at least 15 to 30 minutes before making the coffee, **making sure the filter holder is attached to the appliance** (check that the steam knob is closed). To attach the filter holder, position it under the boiler outlet with the handle towards the left (see fig. 5), push it upwards and at the same time rotate the handle firmly towards the right.

Wait for half an hour, then make the coffee as described in the following section.

Alternatively, you can preheat more rapidly by proceeding as follows:

1. Turn the appliance on by pressing the ON/OFF button (fig. 4) and attach the filter holder to the appliance without adding ground coffee.
2. Place a cup under the filter holder.
Use the same cup as will be used to prepare the coffee in order to preheat it.
3. Wait for the OK indicator light to come on (fig. 6), then immediately press the coffee knob (fig. 7). Run the water off until the OK indicator light goes out, then interrupt delivery by pressing the coffee button again (fig. 7).
4. Empty the cup. Wait until the OK indicator light comes on again then repeat the same operation.
(It is normal for a small and harmless puff of steam to be given off when removing the filter holder).

HOW TO PREPARE ESPRESSO COFFEE USING FILTER HOLDER FOR GROUND COFFEE

1. After preheating the appliance as described above, place the ground coffee filter in the filter holder, making sure the projection is correctly inserted into the slot as shown in fig. 8. Use the smaller filter to make one coffee or the larger filter to make two coffees.
2. To make a single coffee only, place one measure (about 7 g) of ground coffee in the filter holder (fig. 9). To prepare two coffees, place two measures (about 6+6 g) of ground coffee in the filter holder. Fill the filter a little at a time to prevent the ground coffee from overflowing.

IMPORTANT: for correct operation, before adding ground coffee to the filter holder, clean the filter holder of residues of ground coffee from the previous infusion.

3. Distribute the ground coffee evenly and press it down with the presser (fig. 10). *NB: Correct pressing of the ground coffee is essential to obtain a good espresso. If pressing is excessive, coffee delivery will be too slow and the froth will be dark. If pressing is too light, coffee delivery will be too rapid and the froth will be skimpy and light coloured.*
4. Remove any excess coffee from the rim of the filter holder and attach the filter holder to the appliance. Rotate firmly (fig. 5) to avoid leaks of water.
5. Place the cup or cups under the filter holder (fig. 11). You are recommended to heat the cups before making the coffee by rinsing them with hot water or placing them to warm on the top of the appliance for at least 15-20 minutes (fig. 12).
6. Make sure the OK light (fig. 6) is on (if off, wait until it comes on), then press the coffee button (fig. 7). When the required quantity of coffee has been delivered, press the same button again (fig. 7). (You must not run off coffee for more than 45 seconds at a time).
7. To remove the filter holder, rotate the handle from right to left.
IMPORTANT: to avoid splashes, never remove the filter holder while the appliance is delivering coffee.
8. To eliminate the used coffee grounds, block the lever in place using the lever incorporated in the filter holder and empty the coffee by turning the filter holder upside down and tapping (fig. 13).
9. To turn the coffee machine off, press the ON/OFF button (fig. 4).

HOW TO PREPARE ESPRESSO COFFEE USING PODS

1. Preheat the appliance as described in the section "PREHEATING THE COFFEE UNIT", making sure the filter holder is attached. This obtains a hotter coffee.

NB: Use pods conforming to the ESE standard indicated on the pack with the following logo:



The ESE standard is a system accepted by leading pod producers and enables espresso coffee to be prepared simply and cleanly.

2. Place the small filter (1 cup or pods) in the filter holder, making sure the projection is correctly inserted in the slot as shown in fig. 8.
3. Insert a pod, centring it as far as possible on the filter (fig. 14).
Always follow the instructions on the pod pack to position the pod on the filter correctly.
4. Attach the filter holder to the appliance. Always rotate as far as it will go (fig. 5).
5. Proceed as in points 5, 6 and 7 in the previous paragraph.

HOW TO MAKE CAPPUCCINO COFFEE

1. Prepare the espresso coffees as described in the previous paragraphs, using sufficiently large cups.
2. Press the steam button (fig. 15) and wait for the OK light to come on (fig. 6). This indicates that the boiler has reached the ideal temperature for steam production.
3. In the meantime, fill a recipient with about 100 grams of milk for each cappuccino to be prepared. The milk must be at refrigerator temperature (not hot!). In choosing the size of the recipient, bear in mind that the milk doubles or triples in volume.

NB: YOU ARE RECOMMENDED TO USE SEMI-SKIMMED MILK AT REFRIGERATOR TEMPERATURE.

4. Place the recipient containing the milk under the cappuccino maker (fig. 16).
5. Dip the cappuccino maker into the milk for about 5 mm and turn the steam knob anticlockwise (fig. 17), taking care not to immerse the raised line on the cappuccino maker (indicated by the arrow in fig.

appearance. To obtain a creamier froth, dip the cappuccino maker into the milk and rotate the container with slow movements from the bottom upwards.

6. When the required temperature is reached (60°C ideal), interrupt steam delivery by rotating the steam knob clockwise and at the same time pressing the steam button (fig. 15).
7. Pour the frothed milk into the cups containing the espresso coffee prepared previously. The cappuccino is ready. Sweeten to taste and, if desired, sprinkle the froth with a little cocoa powder.

NB: To prepare more than one cappuccino, first prepare all the coffees then at the end prepare the froth for all the cappuccinos.

NB: to make coffee again after the milk has been frothed, cool down the boiler first or the coffee will be burnt.

To cool it, place a container under the boiler and press the steam button and run off water until the OK light goes out.

Make the coffee as described in the previous paragraphs.

NOTE: A maximum of 60 seconds steam delivery is recommended and do not froth milk more than 3 times in sequence.

IMPORTANT: always clean the cappuccino maker after use. Proceed as follows:

1. Discharge a little steam for a few seconds by rotating the steam knob (fig. 18). This empties the milk left inside the steam spout.
IMPORTANT: To ensure hygiene, you are recommended to follow this procedure each time you make cappuccino to avoid milk stagnating in the circuit.
2. With one hand, hold the cappuccino tube firmly with the other unscrew the cappuccino maker by rotating clockwise and extracting downwards (fig. 19).
3. Remove the nozzle from the steam tube by pulling it downwards (fig. 20).
4. Wash the cappuccino maker and steam tube thoroughly with warm water.
5. Make sure the two holes shown in fig. 21 are not blocked. If necessary, clean with a pin.
6. Replace the steam nozzle by inserting it on the steam tube and rotating firmly towards the top.

HOT WATER PRODUCTION

1. Turn the appliance on by pressing the ON/OFF button (fig. 4). Wait until the OK indicator light comes on (fig. 6).
2. Place a recipient under the cappuccino maker.
3. Press the coffee button (fig. 7) and at the same time turn the steam knob anticlockwise (fig. 18). Water comes out of the cappuccino maker;
4. To interrupt delivery of hot water, close the steam knob by rotating clockwise and press the coffee button again (fig. 7). (You should not run off hot water for more than 45 seconds at a time).

CLEANING AND MAINTENANCE

1. Before performing any cleaning operations, leave the appliance to cool down and unplug from the mains socket.
2. Do not use solvents or abrasive cleaning products to clean the appliance. A soft, damp cloth is sufficient.
3. Empty and wash the drip tray and cup tray frequently.
4. Clean the water tank regularly.

IMPORTANT: Never immerse the appliance in water. It is an electrical appliance.

CLEANING THE FILTER HOLDER

About every 200 coffees, clean the filter holder for ground coffee as follows:

- Remove the filter with frother.
- Clean the inside of the filter holder. Never wash in a dishwasher.
- Unscrew the cap of the frother by turning anticlockwise (fig. 22).
- Remove the frother from the container by pushing it from the cap end.
- Remove the gasket.
- Rinse all components and clean the metal filter thoroughly in hot water using a brush (fig. 23). Make sure the holes in the metal filter are not blocked. If necessary, clean with a pin (see fig. 24).
- Replace the filter and gasket on the plastic disk as shown in fig. 25.

Make sure to insert the pin on the plastic disk into the hole in the gasket indicated by the arrow in fig. 25.

- Replace the assembly in the steel filter container (fig. 26), making sure the pin is inserted in the hole in the support (see arrow in fig. 26).
- Finally, screw on the cap by turning clockwise (fig. 27).

CLEANING THE BOILER OUTLET

About every 300 coffees, the espresso boiler must be cleaned as follows:

1. Make sure the appliance is not hot and the boiler is unplugged from the mains;
2. Using a screwdriver, unscrew the screw fixing the espresso boiler outlet filter (fig. 28);
3. Clean the boiler with a damp cloth;
4. Clean the outlet thoroughly in hot water using a brush. Make sure the holes are not blocked. If necessary, clean with a pin (fig. 24).
5. Rinse under running water, rubbing all the time;
6. Screw the boiler outlet back on.

Failure to clean as described above invalidates the guarantee.

DESCALING

You are recommended to descale the coffee machine about every 200 coffees or a maximum of every 6 months.

You should use a commercially available product specifically for descaling espresso coffee machines. If such a product is not available, proceed as follows:

1. Fill the tank with half a litre of water;
2. Dissolve 2 spoonfuls (about 30 grams) of citric acid (obtainable from chemist's or drug stores);
3. Press the ON/OFF button and wait for the OK indicator light to come on.
4. Make sure the filter holder is not attached. Place a recipient under the boiler outlet.
5. Press the coffee button, empty for about 1/4 capacity the tank by turning the steam knob clockwise now and then to run off a little solution.
6. Turn the appliance off and leave the solution to work for 5 minutes.
7. Repeat step 5 for other 3 times to empty the tank completely.
8. To eliminate residues of solution and scale, rinse the tank well, fill with clean water (without citric acid) and replace in position.
9. Press the coffee button and run the water off until the tank is completely empty;
10. Interrupt water run-off and repeat operations from step 9 again.

Repair of damage to the coffee machine caused by scale is **not covered by the guarantee unless descaling is performed regularly as described above.**

PROBLEM

POSSIBLE CAUSES

SOLUTION

No espresso coffee is delivered

- No water in the tank
- The holes in the filter holder spouts are blocked.
- The espresso boiler outlet is blocked
- The filter is blocked
- The tank is incorrectly inserted and the valve on the bottom is not open

- Fill the tank with water
- Clean the spout holes.
- Clean as described in the chapter "Cleaning the boiler outlet"
- Clean as described in the section "cleaning the filter".
- Press the tank down lightly to open the valve on the bottom.

The espresso coffee drips from the edges of the filter holder rather than the holes

- The filter holder is inserted incorrectly
- The espresso boiler gasket has lost elasticity
- The holes in the filter holder spouts are blocked.

- Attach the filter holder correctly rotate firmly as far as it will go.
- Have the espresso boiler gasket replaced at a service centre
- Clean the spout holes.

The espresso coffee is cold

- The espresso OK indicator light was not on when the coffee switch was pressed.
- No preheating performed
- The cups were not preheated

- Wait until the OK light comes on
- Preheat as described in the part "Preheating the appliance".
- Preheat the cups by rinsing them in water or leaving them to rest for a few minutes on the cup warmer tray or

The pump is excessively noisy

- The water tank is empty
- The tank is incorrectly inserted and the valve on the bottom is not open

- Fill tank
- Press the tank down lightly to open the valve on the bottom.

The coffee froth is too light (delivered from the spout too fast)

- The ground coffee is not pressed down firmly enough
- There is not enough ground coffee
- The ground coffee is too coarse
- Incorrect type of ground coffee.

- Press the ground coffee down more firmly (fig. 10).
- Increase the quantity of ground coffee
- Use ground coffee for espresso coffee machines only
- Change the type of ground coffee

The coffee froth is too dark (delivered from the spout too slowly)

- The ground coffee is pressed down too firmly
- There is too much ground coffee
- The espresso boiler outlet is blocked
- The filter is blocked
- The ground coffee is too fine
- The coffee is damp or ground too fine.
- Incorrect type of ground coffee.

- Press the coffee down less firmly (fig. 6).
- Reduce the quantity of ground coffee
- Clean as described in the chapter "Cleaning the espresso boiler outlet"
- Clean as described in the section "cleaning the filter".
- Use ground coffee for espresso coffee machines only
- Use only ground coffee for espresso coffee machines. Make sure it is not damp.
- Change the type of ground coffee



This warranty applies to all products with De'Longhi or Kenwood brand names.

Limited Warranty

What does the warranty cover?

We warrant each appliance to be free from defects in material and workmanship. Our obligation under this warranty is limited to repair at our factory or authorized service center of any defective parts or parts thereof, other than parts damaged in transit. In the event of a products replacement or return, the unit must be returned transportation prepaid. The repaired or new model will be returned at the company expense. This warranty shall apply only if the appliance is used in accordance with the factory directions, which accompany it, and on an Alternating current (AC) circuit.

How long does the coverage last?

This warranty runs for one year (1) from the purchase date found on your receipt and applies only to the original purchaser for use.

What is not covered by the warranty?

The warranty does not cover defects or damage of the appliance, which result from repairs or alteration of the appliance outside our factory or authorized service centers, nor shall it apply to any appliance, which has been subject to abuse, misuse, negligence or accidents. Also, consequential and incidental damages resulting from the use of this product or arising out of any breach of contract or breach of this warranty are not recoverable under this warranty. Some states do not allow the exclusion or limitation of incidental or consequential damage, so the above limitation may not apply to you.

How do you get service?

If repairs become necessary, see contact information below:

U.S. Residents:

Please contact our toll free hotline at 1-800-322-3848 or log onto our website at www.delonghi.com. For all accessories, spare parts or replacement parts, please contact our parts division at 1-800-865-6300.

Residents of Canada: Please contact our toll free hotline at 1-888-335-6644 or log onto our website at www.delonghi.com.

Residents of Mexico: Please refer to the Limited Warranty statement for Mexico.

Please refer to the back page of the manual for De'Longhi addresses.

The above warranty is in lieu of all other express warranties and representations. All implied warranties are limited to the applicable warranty period set forth above. This limitation does not apply if you enter into an extended warranty with De'Longhi. Some states do not allow limitations on how long an implied warranty lasts, so the above exclusions may not apply to you. De'Longhi does not authorize any other person or company to assume for it any liability in connection with the sale or use of its appliance.

How does state law apply?

This warranty gives you specific legal rights, and you may also have other rights, which vary from state to state.