

This Owner's Manual is provided and hosted by [Appliance Factory Parts](http://www.appliancefactoryparts.com).

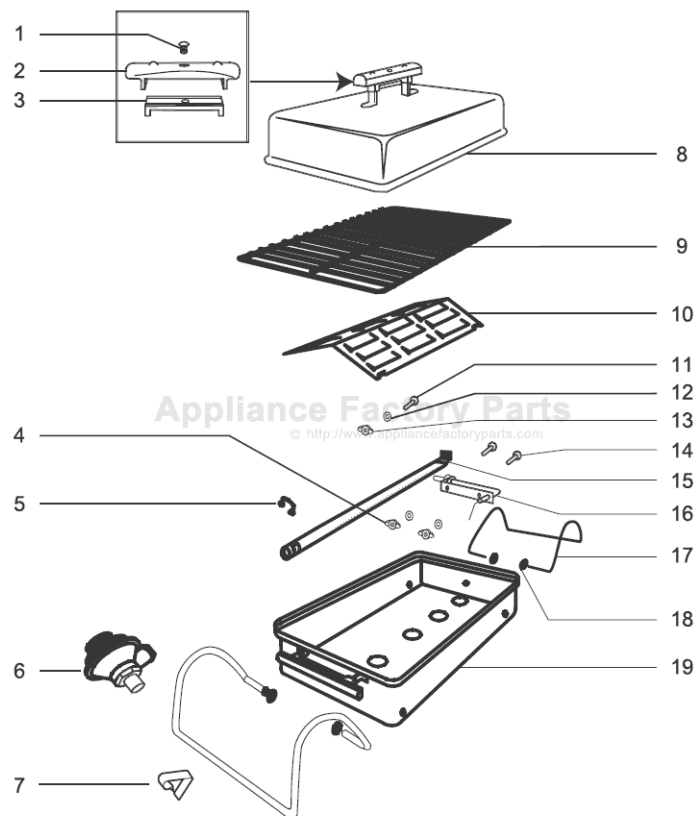

Weber 1520 GO ANYWHERE GAS Owner's Manual

Shop genuine replacement parts for Weber 1520 GO
ANYWHERE GAS



[Find Your Weber Grill Parts - Select From 2037 Models](#)

----- Manual continues below -----



WWW.WEBER.COM

© 2004 Weber-Stephen Products Co. Weber, the kettle silhouette, RapidFire® and the kettle configuration are registered trademarks of Weber-Stephen Products Co., 200 East Daniels Road, Palatine, Illinois 60067 USA. Printed in the U.S.A.



**CHARCOAL & GO-ANYWHERE® GRILL
OWNER'S GUIDE & RECIPES**

**MANUEL DE L'UTILISATEUR
ET DE RECETTES POUR
WEBER GO-ANYWHERE®
& GRILS DE CHARBONS**

**GUÍA DEL PROPIETARIO Y RECETAS
PARA LOS ASADORES DE CARBÓN Y
GO-ANYWHERE®**

Do not discard. This contains important product dangers, warnings, and cautions.



TABLE OF CONTENTS

General Safety	2-3
Helpful Hints.....	4-5
Go-Anywhere® Helpful Hints	6
Charcoal Grill Cooking, Direct Method.....	7
Charcoal Grill Cooking, Indirect Method	8
Grilling Guide	9-10
Recipes.....	11-15

Consignes de Sécurité Générales ...	16-17
Conseils Utiles	18-19
Indices utiles pour le Weber Go-Anywhere®	20
Cuisson au Charbon de Bois, Méthode Directe	21
Cuisson au Charbon de Bois, Méthode Indirecte	22
Guide de Cuisson au Barbecue ...	23-24
Recettes.....	25-29

Instrucciones Generales de Seguridad.....	
Sugerencias Prácticas ...	
Sugerencias Prácticas para Asadores Go-Anywhere® ..	
Cocinando en Asador de Carbón, Método Directo. ...	
Cocinando en Asador de Carbón, Método Indirecto ...	
Guía para Asar.....	
Guía para Cocinar en el Asador	
Recetas	

If you need replacement parts or have questions about the assembly, use or maintenance of your grill, please call Weber Customer Service.

For purchases made in the U.S.
1-800-446-1071

For purchases made in Canada
1-800-265-2150

For purchases made in Mexico
(33) 31 22 12 23

Si vous avez besoin de pièces de rechange ou si vous avez des questions sur le montage, l'utilisation ou l'entretien de votre grill, veuillez consulter le Service Client de Weber.

Pour les achats effectués aux États-Unis:
1-800-446-1071

Pour les achats effectués au Canada:
1-800-265-2150

Pour les achats effectués au Mexique:
(33) 31 22 12 23

Si necesita partes de repuesto o tiene preguntas acerca del ensamblaje, uso o mantenimiento del asador, por favor llame al Departamento de Servicio al Cliente de Weber.

Para compras hechas en los Estados Unidos:
1-800-446-1071

Para compras hechas en Canadá:
1-800-265-2150

Para compras hechas en México:
(33) 31 22 12 23

GENERAL SAFETY

SAFETY SYMBOLS will alert you to important **SAFETY** information.

Signal words **DANGER**, **WARNING**, or **CAUTION** will be used with the **SAFETY SYMBOL**.

DANGER will identify the most serious hazard.

Please carefully read all safety information contained in this Owner's Guide.

DANGER

- This grill is designed for outdoor use only. If used indoors, toxic fumes will accumulate and cause serious bodily injury or death.
- Do not add charcoal starter fluid or charcoal impregnated with charcoal starter fluid to hot or warm charcoal.
- Do not use gasoline, alcohol, or other highly volatile fluids to ignite charcoal. If using charcoal starter fluid, remove any fluid that may have drained through the bottom vents before lighting the charcoal.
- Do not leave infants, children, or pets unattended near a hot grill.
- Do not attempt to move a hot grill.
- Do not use grill within five feet of any combustible material. Combustible materials include, but are not limited to wood or treated wood decks, patios or porches.
- Do not use grill unless all parts are in place. Make sure the ash catcher is properly attached to the legs underneath the bowl of the grill.

- Do not remove ashes until they are completely burned out and extinguished.
- Do not wear clothing with sleeves while lighting or cooking.
- Do not use grill in high winds.

GO-ANYWHERE®

- Discard used and empty fuel tanks in a safe place.
- Store spare fuel tanks in a well-ventilated area away from heat.
- Do not puncture or burn fuel tanks.
- Always remove lid before lighting your grill.
- Do not operate the grill if a gas leak is present.
- Do not use a flame to check for gas leaks.
- Do not attempt to disconnect the regulator or any gas fitting until the unit is in operation.
- Do not place barbecue grill on a combustible surface, he

GENERAL SAFETY

conducted through the legs of portable grills.

- Do not enlarge orifice or burner ports when cleaning the valves or burner.
- Do not use charcoal or lava rock in your gas barbecue grill.
- Use the regulator that is supplied with the barbecue.

WARNING

- Keep the grill in a level position at all times.
- Remove the lid from the grill while lighting and getting the charcoal started.
- Always put charcoal on top of the charcoal grate and not directly into the bottom of the bowl.
- Never touch the cooking or charcoal grate or the grill to see if they are hot.
- Use barbecue mitts or hot pads to protect hands while cooking or adjusting the vents.
- Use proper barbecuing tools with long, heat-resistant handles.
- Use the hook on the inside of the lid to

hang the lid on the side of the bowl of the grill. Avoid placing a hot lid on carpet or grass. Do not hang the lid on the bowl handle.

- To extinguish the coals, place the lid on the bowl and close all of the vents (dampers). Make sure that the vents/dampers on the lid and the bowl are completely closed. Do not use water because it will damage the porcelain finish.
- To control flare-ups, place the lid on the grill. Do not use water.
- Handle and store hot electric starters carefully.
- Keep electrical cords away from the hot surfaces of the grill.

GO-ANYWHERE® WARNING

Combustion byproducts produced when using this product contain chemicals known to the State of California to cause cancer, birth defects, or other reproductive harm.

CAUTION

- Lining the bowl with aluminum foil can obstruct the air flow. Insert a drip pan to catch drippings from cooking by the Indirect method.
- Using sharp objects to clean the cooking grate or remove the grill can damage the finish.
- Using abrasive cleaners to clean the cooking grate or the grill itself will damage the finish.

**FAILURE TO HEED
DANGER, WARNING,
CAUTION STATEMENTS
MAY CAUSE SERIOUS
BODILY INJURY OR
OR A FIRE OR EXPLOSION
RESULTING IN DEATH
PROPERTY.**

TO START A CHARCOAL GRILL

- Remove the lid and open all air vents before building the fire. NOTE: For proper airflow, remove accumulated ashes from the bottom of the grill if present (only after the coals are fully extinguished). Charcoal requires oxygen to burn, so be sure nothing clogs the vents.
- Mound the briquets into a pyramid-shaped pile or pile the charcoal into a Weber® RapidFire® chimney starter.
- Place either Weber® FireStarters™ lighter cubes (they are non-toxic, odorless and tasteless) or crumpled newspaper under the pile of briquets and light. NOTE: We purposely left out instructions for using lighter fluid. That's because we think the choices previously outlined are superior. Lighter fluid is messy and can impart a chemical taste to your food unless it is thoroughly burned off. If you choose to use lighter fluid, follow the manufacturer's instructions and NEVER add lighter fluid to a burning fire.

- When coals are covered with a light grey ash (usually 25 to 30 minutes), arrange the coals with long-handled tongs according to the cooking method you are going to use.
- For additional smoke flavor, consider adding hardwood chips or chunks (soaked in water for at least 30 minutes and drained) or moistened fresh herbs such as rosemary, thyme, or bay leaves. Place the wet wood or herbs directly on the coals just before you begin cooking.
- When removing the grill lid during cooking, lift to the side, rather than straight up. Lifting straight up may create suction, drawing ashes up onto your food.

EASY STEPS TO GRILLING GREATNESS

Follow these tips and you won't go wrong. And neither will your dinner.

- Direct, Indirect, or a little of both? Read the recipe and look for the instructions for setting up your grill. There are two methods of cooking in a Weber® grill—

Direct and Indirect. See the following pages for specific instructions.

- Don't try to save time by cooking on a grill that's not quite ready. Let the charcoal burn until it has a light ash coating (keep the lid closed until the fire does not go out).
- Use a spatula and tongs instead of a fork. You've probably seen people poking their meat with a fork, which causes juices and flavor to be lost. That can dry out your food.
- Make sure the food fits on the grill. The lid down. At least 1 inch of space between the food and the grill.
- Resist the urge to open the grill lid on your dinner every couple of minutes. Every time you lift the lid, you lose heat, which means it will take longer to cook dinner on the table.
- Unless the recipe calls for it, don't turn food over only once.
- You will control flare-ups by adjusting cooking time, and get the best results if you grill with the lid closed.

HELPFUL HINTS

- Resist the urge to use a spatula to press down on foods such as burgers. You'll squeeze out all that wonderful flavor.
- A light coating of oil will help brown your food evenly and keep it from sticking to the cooking grate. Always brush or spray oil on your food, not the cooking grate.

FOOD SAFETY TIPS

- Wash your hands thoroughly with hot, soapy water before starting any meal preparation and after handling fresh meat, fish, and poultry.
- Do not defrost meat, fish, or poultry at room temperature. Defrost in the refrigerator.
- Never place cooked food on the same plate the raw food was on.
- Wash all plates and cooking utensils which have come into contact with raw meats or fish with hot, soapy water and rinse.

USE OF WEBER RECIPES

- All recipes in this book have been developed on the basis of 70°F/21°C weather and little or no wind. Therefore, if you are cooking on a cold and/or windy day or at high altitudes, it may be necessary to allow more time.
- The cooking times in this book should be used as guidelines, not exact cooking times, as much depends upon the size and thickness of the food.

EASY GRILL CARE

Add years to the life of your grill by giving it a thorough cleaning once a year.

IT'S EASY TO DO:

- Make sure the grill is cool and the coals are totally extinguished.
- Remove the cooking and warming grates.
- Remove ashes.
- Wash your grill with a mild detergent and water. Rinse well with clean water and wipe dry.
- It is not necessary to wash the cooking grate after each use. To loosen residue with a brush or crumpled aluminum foil, then wipe off with paper towels.

ATTACHING THE LP CYLINDER

- Turn burner control valve clockwise to the LOCK/OFF position. Push the cylinder slightly into valve while turning clockwise until a snug fit is obtained.
- Check the gas connection for leaks. Mix a couple tablespoons of liquid detergent with an equal amount of water. Be sure to leave the burner control valve to the LOCK/OFF position. Wet the connections with the detergent solution, turn heat control valve on and watch for bubbles. If bubbles form or if a bubble grows, there is a leak.
- If there is a leak, check the fitting, make sure it is tight and recheck the connections.
- Check for gas leaks each time you disconnect and reconnect the gas supply.

LIGHTING YOUR GAS GRILL

- Always remove the lid before lighting your grill.
- With Flavorizer® Bar in place, turn the burner control valve to the HIGH

position and push the igniter button repeatedly until a flame appears on the burner. Check to see if both sides of the burner are lit by looking through the viewing hole in the Flavorizer Bar.

- Replace lid and preheat for 10 minutes.

WARNING: If the burner does not light, turn the burner control valve to OFF and wait five minutes to let the gas clear before you try again or try to light with a match.

Manual lighting - with a lit match in one hand, turn burner control valve to the HIGH position and place match into one of the four holes underneath the grill.

EASY GAS GRILL CARE

Your gas grill is equipped with the advanced Flavorizer® System that eliminates messy, grease-collecting lava rocks. Gas grill care (and delicious gas grill cooking) was never easier. Follow these easy steps frequently:

- While lid is warm, wipe inside with paper towels to prevent grease build-up.

- After cooking, burn grease off by turning burner control valve to OFF for several minutes with lid closed.
- Do not wash cooking grate with detergent. Use a stiff bristle grill brush or crumpled aluminum foil. Then wipe with paper towel.

Thoroughly clean your gas grill once a year.

IT'S EASY TO DO:

- Remove cooking grate and Flavorizer® Bar.
- Remove tubular burner (refer to Assembly Instructions). To remove: Take out burner nut and lock washer (on inside unit). Lift tubular burner slide out of grill.
- Wash with a mild detergent. Rinse well. Wash Flavorizer® Bar and cooking grate with warm water. Rinse, then wipe dry with paper towel.
- Reinstall tubular burner, burner nut and lock washer, and cooking grate.

CHARCOAL GRILL COOKING

DIRECT METHOD

The Direct Method means that the food is cooked directly over prepared coals. For even cooking, food should be turned once, halfway through the grilling time. Use the Direct Method for foods that take less than 25 minutes to cook: steaks, chops, kabobs, vegetables, and the like.

1. Open all vents.
2. Heap the recommended amount of charcoal briquets in the center of the charcoal grate (refer to the chart below).
3. Ignite the charcoal briquets. Leave the lid off until the briquets have a light coating of grey ash, about 25 to 30 minutes.
4. Spread prepared briquets evenly across the charcoal grate.
5. Position the cooking grate over the coals.
6. Place food on the cooking grate.
7. Place the lid on the grill. Consult your recipe for recommended cooking times.



Grill Diameter	Briquets Needed
14 1/2" (37 cm)	30
18 1/2" (47 cm)	40
22 1/2" (57 cm)	50
37 1/2" (95 cm)	150

CHARCOAL GRILL COOKING

INDIRECT METHOD

Use the Indirect Method for foods that require 25 minutes or more of grilling time or for foods so delicate that direct exposure to the heat source would dry them out or scorch them. Examples include roasts, bone-in poultry pieces, and whole fish as well as delicate fish fillets. To set up for Indirect cooking, prepared charcoal briquets are set on either side of the food. Heat rises, reflects off the lid and inside surfaces of the grill, and circulates to slowly cook the food evenly on all sides. There's no need to turn the food over.

NOTE: For meats that require more than one hour to cook, additional briquets must be added to each side as indicated in the chart below.

1. Open all vents.
2. Place the recommended amount of charcoal briquets on each side of the charcoal grate (refer to the chart below). Leave enough room for a drip pan between the coals.

3. Ignite the charcoal briquets, remove the lid off until the coals are covered with a thin coating of grey ash, about 15-20 minutes.
4. Place a drip pan between the charcoal briquets in the center of the charcoal grate.
5. Position the cooking grate over the coals.
6. Place food on the cooking grate above the drip pan.
7. Place the lid on the grill. Refer to the recipe for recommended cooking time.



Charcoal Briquet Guide for the Indirect Method of Cooking

Grill Diameter	Standard Briquets for first hour	Standard Briquets to add for each additional hour
14 1/2" (37 cm)	9 per side	6 per side
18 1/2" (47 cm)	20 per side	7 per side
22 1/2" (57 cm)	25 per side	8 per side
37 1/2" (95 cm)	75 per side	22 per side

GRILLING GUIDE

The following cuts, thicknesses, weights, and grilling times are meant to be guidelines rather than hard and fast rules. Cooking times are affected by such factors as altitude, wind, outside temperature, and desired doneness. Two rules of thumb: Grill steaks, fish fillets, boneless chicken pieces, and vegetables

using the Direct Method for the time given on the chart or to the desired doneness, turning once halfway through grilling time. Grill roasts, whole poultry, bone-in poultry pieces, whole fish, and thicker cuts using the Indirect Method for the time given on the chart or until an instant-read thermometer reaches the desired

internal temperature. Cook beef and lamb are for the definition of medium done otherwise noted. Let roast meat, and thick chops and 5 to 10 minutes before ca internal temperature of the by 5 to 10 degrees during

Beef	Thickness/Weight	Approximate Grilling Time
Steak: New York, porterhouse, rib-eye, T-bone, or tenderloin	1 inch thick	6 to 8 minutes (medium rare) Direct High
	1-1/2 inches thick	12 to 16 minutes; sear 8 to 10 minutes Direct High grill 4 to 6 minutes (medium rare) Indirect High
	2 inches thick	18 to 22 minutes; sear 8 to 10 minutes Direct High grill 10 to 12 minutes (medium rare) Indirect High
Flank Steak	1-1/2 to 2 pounds, 3/4 inch thick	12 to 15 minutes Direct Medium
Ground beef patty	3/4 inch thick	8 to 10 minutes Direct Medium

Pork	Thickness/Weight	Approximate Grilling Time
Chop: rib, loin, or shoulder	3/4 to 1 inch thick	10 to 15 minutes Direct Medium
	1-1/4 to 1-1/2 inches thick	14 to 18 minutes; sear 8 minutes Direct High, grill 6 to 8 minutes Indirect Medium
Loin chop, boneless	3/4 to 1 inch thick	10 to 12 minutes Direct Medium
Ribs: country-style, baby back, or spare ribs	3 to 4 pounds	1-1/2 to 2 hours Indirect Medium

GRILLING GUIDE

Poultry	Thickness/Weight	Approximate Grilling Time
Chicken breast, boneless, skinless	6 ounces	8 to 12 minutes Direct Medium
Chicken thigh, boneless, skinless	4 ounces	8 to 10 minutes Direct Medium
Chicken pieces, bone-in breast/wing		30 to 40 minutes Indirect Medium
Chicken pieces, bone-in leg/thigh		40 to 50 minutes Indirect Medium
Chicken, whole	3-1/2 to 5 pounds	1 to 1-1/2 hours Indirect Medium
Cornish game hen	1-1/2 to 2 pounds	30 to 45 minutes Indirect Medium
Turkey, whole, unstuffed	10 to 11 pounds	1-3/4 to 2-1/2 hours Indirect Medium
	12 to 14 pounds	2-1/4 to 3 hours Indirect Medium
	15 to 17 pounds	2-3/4 to 3-3/4 hours Indirect Medium

Fish & Seafood	Thickness/Weight	Approximate Grilling Time
Fish, fillet or steak	1/4 to 1/2 inch thick	3 to 5 minutes Direct High
	1 to 1-1/4 inches thick	10 to 12 minutes Direct High
Fish, whole	1 pound	15 to 20 minutes Indirect Medium
	3 pounds	30 to 45 minutes Indirect Medium
Note: General rule for grilling fish: 4 to 5 minutes per 1/2 inch thickness; 8 to 10 minutes per 1 inch thickness.		

Vegetables	Approximate Grilling Time
Asparagus	6 to 8 minutes Direct Medium
Corn, in husk/husked	25 to 30 minutes Direct Medium, in husk / 10 to 12 minutes Direct Medium, husked
Mushroom, shiitake or button / portabello	8 to 10 minutes Direct Medium, shiitake or button / 12 to 15 minutes Direct Medium, portabello
Onion, halved / 1/2-inch slices	35 to 40 minutes Indirect Medium / 8 to 12 minutes Direct Medium
Potato, whole / 1/2-inch slices	45 to 60 minutes Indirect Medium / 14 to 16 minutes Direct Medium

RECIPES

WHOLE ROAST CHICKEN

Indirect/Medium

- 1 whole chicken, 4 - 5 lbs.
- Olive oil
- Kosher salt
- Freshly ground black pepper

Rinse chicken and pat dry with paper towels. Twist wing tips under back and tie legs together with string. Brush entire outer surface of chicken with oil and lightly season with salt and pepper.

Grill chicken, breast side up, over *Indirect Medium* heat until the internal temperature reaches 180°F/82°C in the thickest part of the thigh and 170°F/77°C in the breast, 1-1/4 to 1-1/2 hours. Transfer chicken to serving platter; let stand 10 minutes before carving.

Makes 4 to 6 servings.

TURKEY

Indirect/Medium

- 1 turkey, 10 to 12 pounds
- Olive oil
- Kosher salt
- Freshly ground black pepper

Remove neck and giblets. Rinse turkey thoroughly and pat dry with paper towels.

Brush outer surface of turkey with oil and season with salt and pepper inside and out. Pull turkey skin over neck and fasten behind back with a skewer. Twist wings under back and tie legs and tail together securely, or tuck legs under band of skin. Grill turkey, breast side up, over *Indirect Medium* heat until turkey is tender; 11 to 13 minutes per pound or to an internal temperature of 180°F/82°C in the thickest part of the thigh and 170°F/77°C in the breast. When turkey is about two-thirds done, cut the band of skin or string holding the legs together.

Remove turkey from cooking grate and let stand 10 minutes before carving.

Makes 10 to 12 servings.

SPICY LAMB KABOBS

Direct/Medium

For the marinade:

- 1/2 cup olive oil
- 1/4 cup red wine vinegar
- 2 tablespoons grated orange zest
- 1 tablespoon lemon juice
- 1 green onion and top, chopped
- 1/4 teaspoon ground cinnamon
- 1/8 teaspoon ground cloves

- 2 pounds lean lamb, cut into 1-1/2" cubes

To make the marinade: Combine marinade ingredients in a shallow dish or plastic bag. Add the lamb and cover, 4 to 6 hours. Drain lamb and discard marinade. Pour reserved marinade into a sauce pan. Bring to a boil over medium heat for 1 full minute.

Arrange lamb on 4 to 6 skewers. Grill over *Direct Medium* heat to medium rare, 10 minutes, turning and basting with marinade once halfway through.

Makes 4 to 6 servings.

BASIC BURGERS

Direct/Medium

- 1-1/2lbs. ground beef (80% lean)
- Kosher salt
- Freshly ground black pepper
- 4 hamburger buns
- Ketchup (optional)
- Mustard (optional)

Gently shape the ground beef into four burgers of equal size and thickness (about 3/4" thick). Season with salt and pepper. Grill the burgers over *Direct Medium* heat until the internal temperature reaches 160°F/73°C for medium, 8 to 10 minutes, turning once halfway through grilling time. During the last 30 seconds, grill the buns over *Direct Medium* heat until lightly toasted.

Serve the burgers hot on the buns with ketchup and mustard, if desired.

Makes 4 servings.

SIMPLE STEAKS

Direct/High

- 4 New York strip, tenderloin, sirloin, or rib-eye beef steaks, about 3/4 lb. each and 1" thick
- Kosher salt
- Freshly ground black pepper
- Extra-virgin olive oil

Season both sides of the steaks with salt and pepper, pressing the spices into the meat. Allow to stand at room temperature for 20 to 30 minutes before grilling. Lightly spray or brush both sides of the steaks with olive oil. Grill the steaks over *Direct High* heat until the internal temperature reaches 145°F/62°C for medium rare, 6 to 8 minutes, turning once halfway through grilling time.

Remove from the grill and stand for 3 to 5 minutes. Serve warm.

Makes 4 servings.

CLASSIC BONELESS PORK CHOPS

Direct/Medium

- 4 boneless pork loin chops about 1" thick
- Kosher salt
- Freshly ground black pepper
- Extra-virgin olive oil

Season the pork chops with salt and pepper. Lightly brush or spray both sides with olive oil. Allow to stand at room temperature for 20 minutes before grilling.

Grill the chops over *Direct Medium* heat until the juices run clear, 10 to 12 minutes, turning once halfway through grilling time. Serve warm.

Makes 4 servings.

RECIPES

CLASSIC BONELESS CHICKEN BREASTS

Direct/Medium

- 4 boneless, skinless chicken breast halves, about 6 oz. each
- Kosher salt
- Freshly ground black pepper
- Extra-virgin olive oil

Rinse the chicken breasts under cold water, pat dry with paper towels, and season with salt and pepper. Lightly brush or spray both sides with olive oil. Grill the chicken over *Direct Medium* heat until the juices run clear and the meat is no longer pink in the center, 8 to 10 minutes, turning once halfway through grilling time. Serve warm.

Makes 4 servings.

CLASSIC BONE-IN CHICKEN BREASTS

Indirect/Medium

- 4 chicken breast halves (with bone and skin), 10-12 oz. each
- Kosher salt
- Freshly ground black pepper
- Extra-virgin olive oil

Rinse the chicken breasts under cold water, pat dry with paper towels, and season with salt and pepper. Lightly brush or spray both sides with olive oil. Grill the chicken, skin side up, over *Indirect Medium* heat until the juices run clear and the meat is no longer pink at the bone, 30 to 40 minutes. For crispier skin, grill the breasts, skin side down, over *Direct Medium* heat during the last 5 minutes of grilling time. Serve warm.

Makes 4 servings.

FABULOUS FISH FILET

Direct/High

- 4 swordfish or halibut fillets, about 1" thick
- Kosher salt
- Freshly ground black pepper
- Extra-virgin olive oil
- Lemon wedges (optional)

Lightly brush or spray both sides with olive oil and season with salt and pepper. Grill over *Direct High* heat until opaque, 8 to 10 minutes, turning once halfway through grilling time. Serve warm with lemon wedges if desired.

Makes 4 servings.

SALMON STEAK KYOTO

Direct/Medium

For the marinade:

- 1/3 cup soy sauce
- 1/4 cup orange juice concentrate
- 2 tablespoons olive oil
- 2 tablespoons tomato sauce
- 1 tablespoon spring onion and top, minced
- 1 teaspoon lemon juice
- 1/2 teaspoon prepared mustard
- 1/2 teaspoon minced ginger root
- 1 clove garlic, minced

- 4 salmon steaks, about 1" thick
- Olive oil

To make the marinade: In a shallow, glass baking dish, combine the marinade ingredients. Add the salmon and turn to coat each side. Cover and refrigerate 30 to 60 minutes. Remove the salmon and reserve the marinade. Pour the reserved marinade into a small saucepan. Bring to a boil over high heat and boil for 1 full minute.

Lightly brush or spray salmon with oil. Grill over *Direct Medium* heat until fish is tender and flakes with a fork, 5 to 10 minutes, depending upon thickness of fish. Turn salmon and brush with marinade once halfway through grilling time.

Makes 4 servings.

SHRIMP KABOBS WITH CURRY BUTTER

Direct/High

For the curry butter:

- 1/2 cup butter
- 2 tablespoons finely chopped onion
- 1 teaspoon snipped fresh dill
- 1 to 1-1/2 teaspoons curry powder
- Dash garlic powder

- 16 to 20 jumbo shrimp (1-1/2 to 2 pounds), peeled and deveined
- Olive oil
- Lime or lemon wedges
- Fresh dill or parsley sprigs

To make the curry butter: In a small pan, melt the butter over medium-high heat. Stir in the onion, dill, curry powder, and garlic powder; cook 5 minutes.

Thread shrimp on skewers, leaving space between pieces. Lightly brush or spray the shrimp with olive oil. Grill over *Direct High* heat until the shrimp turn pink and are tender, 2 to 5 minutes, turning and brushing with the curry butter once halfway through grilling time. Arrange shrimp on serving plate. Garnish with lime wedges and dill.

Makes 4 servings.

SWEET CORN IN HULL

Direct/Medium

Trim excess silk off end of corn cobs with shears. Place corn in a deep container with cold water and soak at least 1 hour. When ready to grill, remove corn from water and remove excess water.

Grill over *Direct Medium* heat until tender, 15 to 20 minutes, turning 3 times. Use gloves to remove corn and silk before serving.

GRILLED RED PEPPERS STUFFED WITH MOZZARELLA

Indirect/Medium

- 1 small loaf crusty Italian bread
- 3 tablespoons olive oil
- 3 medium sweet red bell peppers
- 1 cup fresh mozzarella cheese,
cut into small cubes
- 1-1/2 teaspoons dried basil
- 1 clove garlic, finely chopped
- 1 tablespoon olive oil
- Kosher salt
- Freshly ground black pepper

Thinly slice bread, remove crusts and cut into enough 1/2" croutons to make 1 cup.

In a skillet, warm the olive oil, add the croutons, and sauté until golden; drain on paper towels. Cut tops off peppers about 1/2" from top, and reserve tops. Carefully remove seeds and membranes.

In a bowl combine croutons, mozzarella, basil, garlic, and oil. Mix well, adding salt and pepper to taste. Stuff peppers with mixture, replace tops and secure with toothpicks. Grill peppers, top sides up, over *Indirect Medium* heat until peppers are soft but still hold their shape, 12 to 15 minutes. Remove tops and cut in half lengthwise.

Makes 6 servings.

PARADISE GRILLED

from *Weber's Big Book of Grilling™*

Indirect/Medium

For the glaze:

- 3/4 cup fresh orange juice
- 1 tablespoon honey
- 1 tablespoon fresh lime juice
- 2 teaspoons cornstarch

- 4 slices fresh pineapple, about
1/2 inch thick each
- 1 teaspoon cracked dried
green peppercorns
or cracked black peppercorns

- 4 scoops vanilla ice cream

To make the glaze: In a small saucepan combine the glaze ingredients and whisk until smooth. Bring to a boil over *Medium High* heat and cook until thickened, 1 to 2 minutes. Keep the glaze warm or reheat when ready to serve.

Season both sides of the pineapple slices with the peppercorns. Grill over *Indirect Medium* heat until well marked, 6 to 8 minutes, turning once halfway through grilling time. Serve each pineapple slice with a scoop of ice cream and some of the glaze drizzled over the top.

Makes 4 servings.