

This Owner's Manual is provided and hosted by [Appliance Factory Parts](#).



HERRMIDIFIER 707U Owner's Manual

[Shop genuine replacement parts for HERRMIDIFIER
707U](#)



[Find Your HERRMIDIFIER Humidifier Parts - Select From 41 Models](#)

----- Manual continues below -----



Duct Mount Centrifugal Atomizer Humidifier

707U

Model 356686-001C (115/60/1)

707U-UK

Model 356686-002C (220/50-60/1)



Manual for:

- **Installation**
- **Operation**
- **Maintenance**

Table of Contents

Introduction	1
Specifications	1
Capacity Selection Guide	2
Operation of Humidifier	2
Installation	
Selecting a Location	3
Physical Installation	5
Final Installation	9
Electrical Installation	10
Humidistat Installation	11
Maintenance.....	12
Unit Diagram and Parts List	14
Warranty	Back cover

CAUTION: Read installation, operation, and maintenance instructions carefully for safe operation. Exercise the usual precautions when working with electricity.

Introduction

Dear Owner:

Congratulations on your choice of a Herrmidifier brand humidification system. Your family can now look forward to breathing more comfortable air, winter after winter. We are committed to providing advanced products that improve the quality of the air you breathe.

The following information will familiarize you with the operation of your new humidifier and provide helpful tips on how to obtain maximum performance from your unit.

Introduction

The benefits of a properly humidified environment (35-50% Relative Humidity) are many. They include both personal comfort as well as the preservation of furniture, draperies, carpets, wooden floors and cabinets, paintings, pianos, etc.. Your home will be more comfortable at a lower temperature (i.e.: 68° F) at 30-40% Relative Humidity (RH) than at 71° to 72° F without controlled humidity. Since every degree of temperature setback represents about 3% of your heating costs, this can possibly represent a significant annual savings.

During the heating season, cold air is brought into the home and heated. When heated, this air dries out and greatly increases its capacity to hold more moisture. By using a humidifier, a source of water is provided to satisfy this increased moisture holding capability, rather than having it drawn from our body surface and the surrounding furnishings in the home.

A properly maintained and efficiently operating humidifier is a source of improved Indoor Air Quality and personal comfort. We hope you will enjoy the benefits of your humidifier.

Specifications

Type of Unit	Centrifugal atomizing
Duct Mounting	Return
GPD @ 140 ° F	6.0 maximum
GPD @ 120 ° F	6.0 maximum
GPD @ 100 ° F	6.0 maximum
Voltages	120V/ 240V
Unit Dimensions	10 1/2" DIA x 12 1/2" H
Standard Equipment	Wall / duct mount humidistat (707U only) Self piercing saddle valve
Features	Centrifugal atomizer Operates on low current, less than a 100w bulb All brass valve assembly Universal mounting options 2 year warranty
Installation Options	
Duct Side Mount	Mounts on face of vertical or side of horizontal return duct Includes independent mounting bracket
Free Standing Wall Mount (707U only)	Mounts behind wall Includes independent mounting bracket Includes discharge extension to extend through wall

Capacity Selection Guide

Sq. Footage of Home	Tight Home (GPD*)	Average Home (GPD*)	Loose Home (GPD*)
1000	0.5	5.0	10.0
1500	3.0	10.0	16.5
2000	5.0	14.0	24.0
2500	7.5	19.0	30.5
3000	10.0	23.5	37.5
4000	14.5	33.0	51.5

* GPD= Gallons Per Day (humidifier capacity)

The above calculations are for reference only and are based on the following:

- Inside temperature 70° F/35% relative humidity
- Outside Temp 20° F /70% relative humidity
- 8 foot ceiling height
- Internal moisture gain of one pound per hour
- Furnace on-time of 70%

This chart uses A.R.I. standard designations:

A "Tight Home" is assumed to be well insulated with vapor barriers, tight storm windows and doors, and a dampered fireplace. Air exchange rate of .50 changes per hour.

An "Average Home" is insulated and has a dampered fireplace, but there are no vapor barriers, storm doors, or storm windows. Air exchange rate of 1.0 change per hour.

A "Loose Home" is generally one constructed before 1930, has little or no insulation, no storm doors, storm windows, weather stripping or vapor barriers, and often no effective dampering of fireplaces. Air exchange rate is as high as 1.5 changes per hour.

Operation

Your centrifugal atomizer type humidifier operates on the principle of breaking down water droplets into a fine mist and atomizing the moisture into the air.

If applicable, set the humidistat in the recommended range of 30-40% relative humidity for automatic humidity control during the heating season (a lower setting may be used to control condensation on single pane windows). During the first heating season, check the mineral buildup in the humidifier every month to establish the proper cleaning schedule. Clean the unit at the end of each heating season, or whenever mineral deposits appear to be impeding the discharge of the water mist.

When shutting the humidifier down for the summer months, start with cleaning any mineral accumulation from the unit. Leave the water turned off and the unit dry. If the furnace fan is to be used for cooling purposes, disconnect power to the humidifier or turn the humidistat to the OFF position.

Selecting a location for the unit

Mounting on face of vertical return duct or side of horizontal return duct

When mounting your humidifier on the face of a horizontal return duct, or on the face of a vertical return duct, certain conditions must be met for its proper operation:

- Mount the humidifier on the vertical or horizontal cold air return duct.
- Locate the humidifier at least four (4) linear feet upstream of either the furnace fan and /or filter and any turn in the duct. This will ensure that condensation does not collect within the duct and cause oxidation (rust).
- Mount the humidifier at least six (6) linear feet (preferably 10 feet) upstream from any electronic air cleaner. Failure to follow this recommendation can cause excessive nuisance arcing and or power supply failure.
- If the duct seams inside the duct are not flat, locate the humidifier at least three (3) linear feet upstream from the seam.
- If the humidification needs of the home require more than one humidifier, each unit should be installed a minimum of (3) linear feet apart.
- DO NOT use this humidifier on the discharge or warm air supply side of a forced air heating system. This will reduce the efficiency of the humidifier and may cause operational problems.
- DO NOT mount the humidifier in a furnace jacket.
- DO NOT install the humidifier where freezing conditions could occur.
- DO NOT install on gravity hot air systems.

Selecting a location for the unit

Mounting behind a wall using the discharge extension (707U only)

When selecting a location for the installation of your humidifier as a free standing unit, certain conditions must be met for its proper operation:

Locate the humidifier in a convenient spot where the working part of the humidifier can be hidden (i.e. closet, stairway, garage, utility room, etc.)

When deciding on the location of the humidifier, please keep in mind the following points:

- The discharge nozzle should be at least two (2) feet below the ceiling and from a vertical wall along the side.
- The discharge nozzle should be about six and a half (6 1/2) feet from the floor. If this is not possible, locate the humidifier in the area of least traffic.
- The humidifier should be located between wall studs to facilitate cutting the discharge hole through the wall.
- No obstructions should be directly in the path of the discharge mist for six (6) feet. This includes, but is not limited to ceiling lights, light cords and ceiling fans.
- DO NOT install the humidifier where freezing conditions could occur.

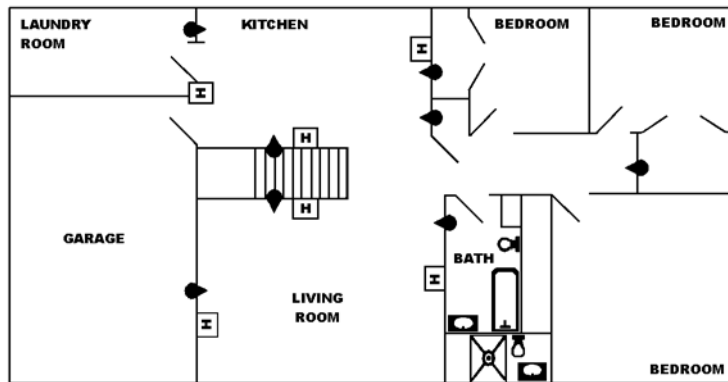

◆ Indicates recommended locations for free standing humidifiers

◻H Indicates humidistat locations

Physical installation

Caution:

Only a trained HVAC servicer or contractor should install this humidifier. Do not connect the unit to the power source until installation is complete. A thorough checkout of the unit installation should be completed before operation. Failure to follow these directions may void the manufacturer's original warranty.

Remember to select a location that is readily accessible for periodic inspection and cleaning of your humidifier. Allow a minimum of 2" clearance in front of the humidifier and 2" below the water pan to allow for maintenance and repair.

Prior to installing this product:

- Read the instructions carefully to ensure safe operation. Failure to follow them could damage the product or cause a hazardous condition.
- Check the ratings given on the product to make sure it is suitable for your application.

Mounting on the face of a vertical return duct or side of a horizontal return

1. Mount the installation template on the side of the cold air return air duct with the center line of the template lined up with the center line of the return air duct. The narrow side of the duct may be used if space permits.
2. Check the template with a level to ensure proper installation of the humidifier.
3. Drill (4) 1/8" diameter holes (as shown on the template) for mounting the wire bracket with sheet metal screws and flat washers provided.
4. Cut out the circle marked on the template. Do not cut this opening undersized.
5. With a hammer and a heavy piece of metal, straighten the metal edges to prevent injury to yourself and damage to the humidifier.
6. Fit the rubber channel around the cut-out to cover the rough edges of the hole and trim to fit.
7. Attach the wire mounting bracket to the duct with (4) #10 sheet metal screws and flat washers (provided).
8. Move the side adjusting arms vertically until the shelf of the wire mounting bracket is level.
9. Mark the duct for securing adjusting arms and drill (2) 1/8" holes. Fasten the arms in this position with (2) #10 sheet metal screws and flat washers (provided).
10. The float and valve assembly have been factory adjusted to maintain 1-1 1/2" of water in the water reservoir pan at normal water pressure. If necessary, bend the float arm to the required position to maintain the water level at other water pressures.
11. Before mounting the humidifier in its final position, carefully rotate the impeller assembly by hand to ensure it rotates freely. Position the humidifier on the wire mounting bracket with the float and valve assembly connection facing the most convenient location. Be sure that the water reservoir pan feet do not rest on the wire bracket and that the water reservoir pan is level.
12. The discharge dome should approach the opening in the duct, however, it should not extend into the duct. There will be no heat loss, due to the negative pressure of the cold air return duct (the air flow will create a vacuum in the duct).

NOTE:

The following items are located in the carton:

- Bottom pan
- Atomizing assembly
- Discharge dome (plastic)
- Wire mounting bracket

The following items are located in the bag identified

"707 SM/STD Hardware Kit":

- Template
- (6) #10 x 3/4" screws
- (6) #10 flat washers
- Rubber channel

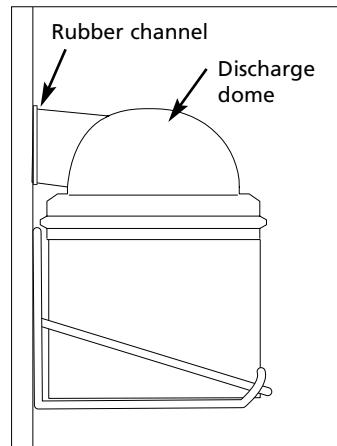
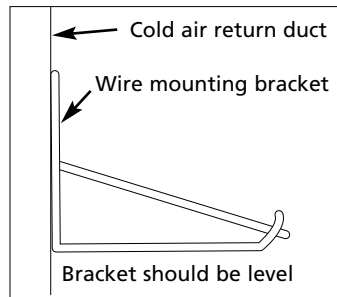

Mounting behind a wall using discharge extension (707U only)

1. Locate the inside wall template and mount on inside wall. The inside wall opening must be cut first. Be sure to follow the limitations noted as A, B, and C printed on the template.
2. Check the template with a level to ensure proper installation of the humidifier.
3. Drill (6) 5/16" diameter holes through the inside wall only as shown on the template for mounting the wire bracket on the wall using the anchor bolts and flat washers provided. Drill a saw access hole through the inside wall only in Area I as shown on the template.
4. Cut out Area I of the inside wall using a saber saw or equivalent. Do NOT cut out Area II at this time. Do NOT cut through the entire wall as the discharge hole on the other side of the wall will be higher up.
5. Measure the thickness of the wall studs using the cutout portion (Area I) on the template. This measurement is used to drill a pilot hole for locating the hole in the outside wall.
6. Drill (1) 1/4" pilot hole through the inside and outside wall at the proper point in Area II on the template. This will mark the proper center for the discharge hole on the outside of the wall.
7. Cut out Area II of the inside wall using a saber saw or equivalent. Do NOT cut through the entire wall.
8. Remove the template from the wall. In the (6) 5/16" diameter holes previously drilled into the inside wall, install the (6) anchor bolts provided. Remove each one of the bolts, and mount the wire mounting bracket to the wall with (6) removed bolts and flat washers.
9. The float and valve assembly have been factory adjusted to maintain 1-1 1/2" of water in the water reservoir pan at normal water pressure. If necessary, bend the float arm to the required position to maintain the water level at other water pressures.
10. When installing the atomizing assembly into the water reservoir pan, be sure that the drip tubes do not interfere with the operation of the float and valve assembly. Interference can be eliminated by rotating the entire atomizing assembly within the water reservoir pan.

NOTE:

The following items are located in the carton:

- Bottom pan
- Extension discharge nozzle
- Atomizing assembly
- Discharge dome (plastic)
- Wire mounting bracket

The following items are located in the bag identified :

"707 TW Hardware Kit":

- Inside wall template
- Outside wall template
- (6) anchor bolts
- (1) flexible connector sleeve
- (2) hose clamps
- (1) bezel

The following items are located in the bag identified :

"707 SM/STD Hardware Kit":

- (6) #10 flat washers

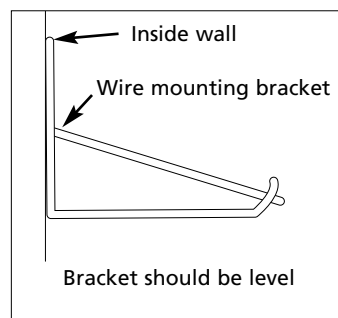

Physical installation

11. Before mounting the humidifier in its final position, carefully rotate the impeller assembly by hand to ensure it rotates freely. Mount the humidifier on the wire mounting bracket with the float and valve assembly connection facing the most convenient location, but providing the least obstruction to traffic. Be sure that the water reservoir pan feet do not rest on the wire bracket and that the water reservoir pan is level.
12. Locate the discharge hole on the outside wall. Mount the outside wall hole template using the center of the pilot hole for reference. A pencil may also be used to find the previously drilled pilot hole. When the outside wall hole template is secured, cut the hole in the outside wall, using a saber saw or equivalent, for the discharge nozzle.
13. Measure the total thickness of the wall, not the stud thickness, but the distance between the surfaces of the inside and outside walls.
14. The length of the discharge extension nozzle (provided) will be 2 5/8" long PLUS the total wall thickness as determined in the previous step. Cut the extension nozzle to length on the square end. The opposite end of the extension nozzle is angled to provide the correct fit with the outside wall.
15. Fit the flexible connector sleeve onto the discharge dome and fasten securely with one (1) hose clamp provided.
16. Insert the angle cut end of the extension discharge nozzle into the hole cut into the inside wall, making sure the white line is pointed UP. Connect the extension discharge nozzle to the discharge dome's flexible connector sleeve. The angle cut end of the extension discharge nozzle should be adjusted so that 5/8" of the tube extends past the outside wall. Secure in position with one (1) hose clamp.
17. Install the cosmetic bezel onto the discharge side of the extension discharge nozzle. Making sure that the bezel sits flat against the wall, 1/4" of the extension discharge nozzle should extend past the bezel. This setup is necessary to prevent excessive condensation.

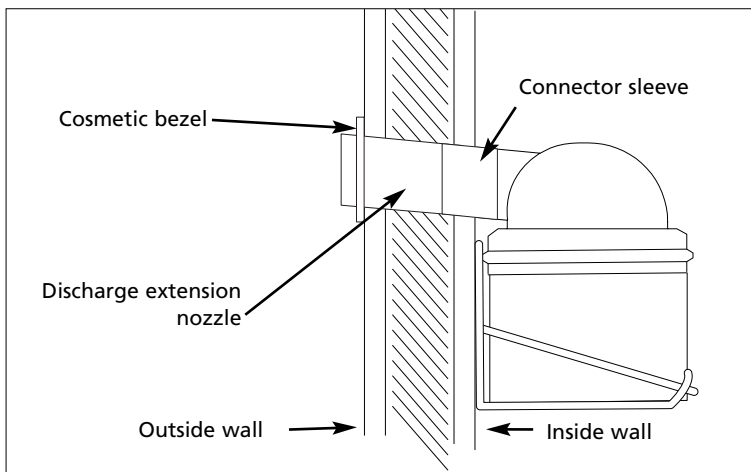

Physical installation

Final installation steps for all mounting locations

- Install the saddle valve on the nearest cold water supply pipe (see the instructions on the package). If applicable, connect the saddle valve upstream of any type of water softener.
- After the saddle valve has been installed and 1/4" copper tubing fitted to the valve, but before attaching the copper tubing to the float and valve assembly, turn the saddle valve to the open position and discharge the water into a bucket or pan. This will allow the water to void the line of any debris that may have accumulated during the installation process.
- Attach the 1/4" copper tubing to the float and valve assembly with the ferrule and compression nut (provided).

Caution: The float and valve assembly must not turn when tightening the copper tubing compression fittings to the humidifier water reservoir pan fitting.

- Turn the water supply on at the saddle valve.
- Check the water level in the water reservoir pan to ensure it is 1-1 1/2" deep.

IMPORTANT:

In installations where accidental overflow could cause water damage, connect a drain hose from the humidifier water reservoir pan overflow tube to a drain. Do NOT use a soldered joint because the overflow tube will become heated and warp the water reservoir pan.

NOTE:

The following items are located in the bag identified:

"707 SM/STD Hardware Kit":

- Saddle valve assembly

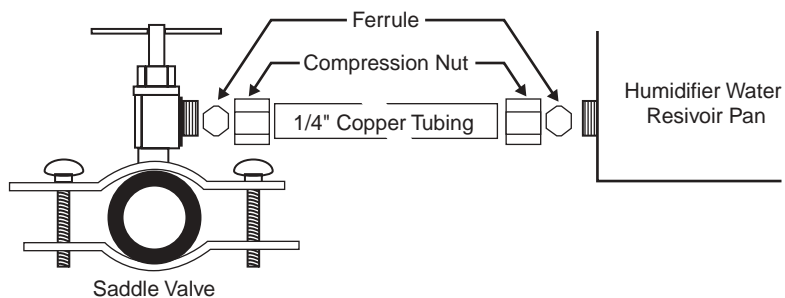

Electrical installation

This humidifier is intended to be wired directly to the integrated control panel on your furnace. The electrical tap will provide power to the humidifier whenever the circulating air blower is in operation.

Read the instructions in the furnace installation manual carefully before attempting installation or operation of this humidifier. Failure to follow these instructions may result in improper installation and therefore, void the manufacturer's warranty.

1. Remove the cover from the junction box in the furnace jacket.
2. Connect the humidifier input leads to the two (2) leads that run to the furnace blower motor. This connection provides for the automatic operation of the humidifier during the heating season.
3. The humidifier will only operate when the furnace blower is in operation.
4. It is recommended to install a humidistat (provided with model 707U) in the system to provide optimum performance when continuous air circulation is desired.
5. If a humidistat is not used in the installation, install an ON/OFF switch in its place. This provides a simple, yet effective, method of turning the humidifier off during the summer months when humidification is not desired.

⚠ WARNING ⚠

Improper electrical wiring can cause personal shock, injury, or property damage. It is required that the unit be installed by a properly qualified HVAC technician or electrician, following NEC and any other local codes.

Wiring diagram for humidifier installation - Return Duct Installation

Furnace wiring connection

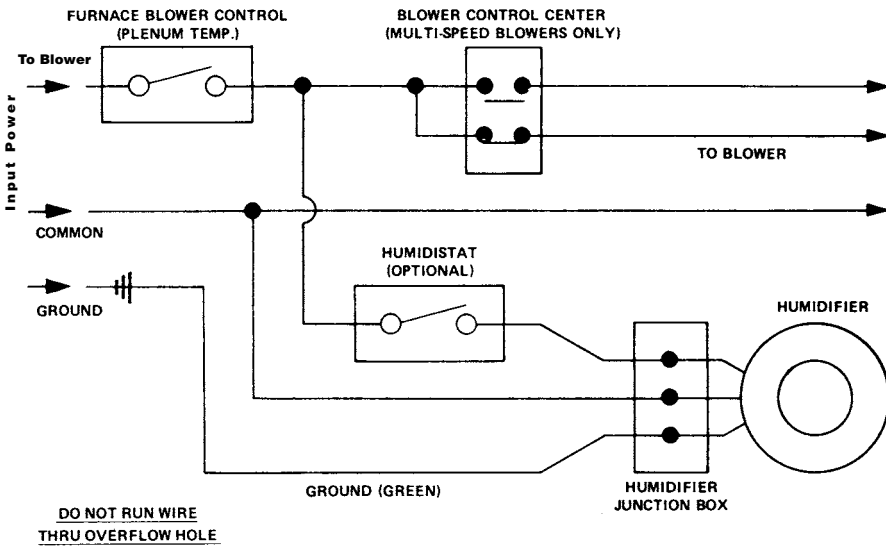

Electrical installation

Wiring diagram for humidifier installation - Free standing installation - (707U only)

-Dedicated wiring connection

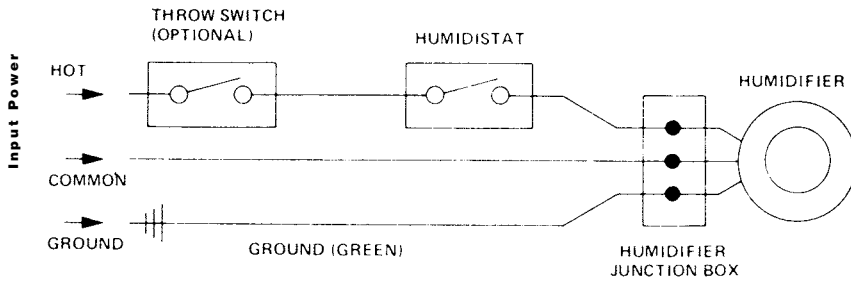

Humidistat installation

Humidistat:

1. Locate the humidistat in the living area (see location of humidifier diagram on page 4), making sure that it is at least five (5) feet from a supply register (duct mounted installation) or discharge nozzle (free standing installation).
2. The humidistat should be installed four and a half (4 1/2) feet above the floor, out of the direct sun and not subject to damage from traffic within the room.
3. If you would like the ability to cut off the electricity to the humidifier for maintenance, a throw -switch may be installed.
4. Turn the humidistat to the highest level (past 60%) and the humidifier should begin to run. The humidifier should stop when the humidistat is turned off.
5. Set the furnace controls and humidistat for the desired conditions (30-40% RH is recommended). Operation of this unit is automatic.
6. If condensation occurs on single pane windows, lower the humidistat setting until the condensation has disappeared.

NOTE: It may take several days for the humidity level in your home to reach comfortable levels.

To enjoy the benefits of a properly humidified environment, periodic cleaning is necessary to control both water and household impurities. Film or scum, which can contain bacteria or fungi, may appear on the water surface, the sides, or bottom of your humidifier. A crusty deposit or scale may also appear and is composed of minerals that have settled out of the water.

To improve the efficiency of your humidifier, and to reduce the possibility of a health hazard, it is recommended that you take the following precautions:

- Follow the manufacturer's recommended cleaning and maintenance instructions below and on the next page.
- The amount of minerals and other impurities in a water source can vary greatly, therefore, the frequency of cleaning the unit also varies.
- During the heating season, check for film or scale build-up in the unit, or any moving part. Establish a proper cleaning schedule to ensure the efficiency of the humidifier.
- An algaecide, such as a humidifier cleaning tablet or bacteriostatic liquid/powder, can be used to combat algae build-up, should it become evident.
- At the end of the winter humidification season, drain and thoroughly clean your humidifier as part of the summer shutdown.

Like your heating system and air conditioning unit, periodic maintenance and cleaning are required to ensure the safe and efficient operation of your humidifier. Due to the operation cycle of the furnace and humidifier, it may require 2 to 5 days to reach the proper humidification level.

⚠ CAUTION ⚠

Before cleaning or servicing this unit, it is recommended that the unit be disconnected from any electrical supply outlet.

Maintenance instructions for models mounted on the face of a vertical return duct, side of a horizontal return duct, or mounted behind a wall using discharge extension

Your humidifier is constructed from quality materials to assure superior performance during normal operation. The motor bearings are permanently lubricated and do not require oiling. The motor is also thermal overload protected against extreme conditions.

To clean the unit:

1. Turn the power to the furnace OFF or turn off the electric switch to the humidifier, if provided.
2. Disconnect the humidifier motor leads.
3. Turn off the humidifier water supply from the saddle valve and remove water line from humidifier.
4. Remove the humidifier from the wire mounting bracket.
5. Remove the discharge dome from the humidifier by pressing on the sides of the dome and lifting upward.
6. Lift the entire atomizing assembly from the water reservoir pan.
7. Remove the pump from the end of the impeller shaft. If the pump is stuck in the motor drive shaft, run hot water over the end of the shaft for a few seconds to loosen the pump.
8. Flush water through the impeller tube, ensuring that the six holes at the top of the impeller tube are open and clear of mineral deposits. A pipe cleaner works well for this cleaning operation.

Note: The impeller tube and pump can become clogged by algae formations prevalent in certain water sources. The addition of 10 drops of bleach to the water reservoir pan each week is advisable.
9. Replace the pump into the impeller shaft.
10. Carefully rotate the impeller to ensure it turns freely. Do not force the impeller shaft to turn or breakage could result.
11. With the atomizing assembly removed, clean the water reservoir pan thoroughly. We suggest either a water/white vinegar solution or liquid humidifier cleaner.
12. Reassemble and remount the humidifier by reversing steps 6, 5, and 4.
13. Reconnect the water line and motor leads to the humidifier, turn on the water supply from the saddle valve and restore electrical power.

Parts List

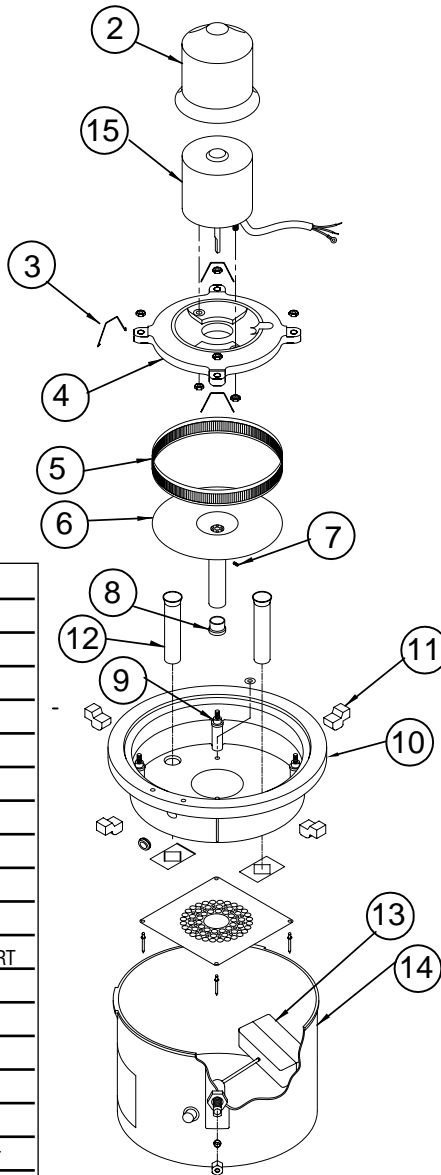
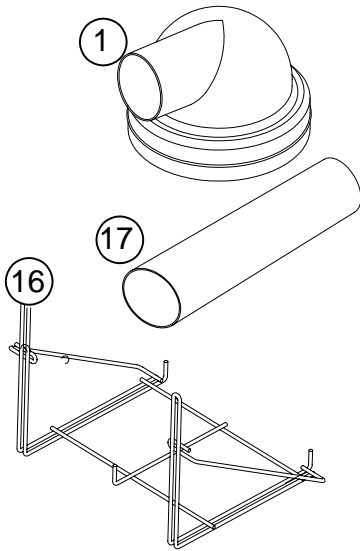

ITEM	707U-UK	707U	PART NO.	DESCRIPTION
1	1	1	40	DISCHARGE DOME
2	1	1	252413-001	MOTOR COVER
3	4	4	19	RETAINER CLIP
4	1	1	352728-001	MOTOR BASE
5	1	1	45	DIFFUSING SCREEN
6	1	1	D9P	IMPELLER
7	1	1	M3	SCREW, SET CUP
8	1	1	8A	IMPELLER PUMP
9	4	4	90	VIBRATION DAMPER
10	1	1	35P	CENTER PAN
11	4	4	23	CENTER PAN SUPPORT
12	2	2	27	DRIP TUBE
13	1	1	92P	FLOAT & VALVE ASM
14	1	1	47BP	PAN
15		1	252596-001	MOTOR 115 VOLT
15A	1		252596-002	MOTOR 220 VOLT
16	1	1	186	MOUNTING BRACKET
17		1	53	EXTENSION NOZZLE
NI		1	3526BO-002C	HUMIDISTAT
NI	1	1	IN-2ST	SADDLE VALVE
NI		1	54	BEZEL

NI = NOT ILLUSTRATED

Warranty

Humidifier Limited Two Year Warranty

This limited warranty covers Herrmidifier Residential Type Humidifiers, excluding duct work, wiring and installation. The manufacturer warrants that all new Herrmidifier Humidifiers are free from defects in material and workmanship under normal, non-commercial use and service. The manufacturer will remedy any covered defects if they appear within 24 months from the date of original installation as evidenced by proof of purchase, subject to the terms and conditions of this Limited Two-Year Warranty stated below:

1. THIS LIMITED TWO-YEAR WARRANTY is granted by CareCo, 415 W. Wabash Ave., P.O. Box 200, Effingham, IL 62401.
2. This warranty shall extend only to any non-commercial owner who has purchased the residential humidifier other than for purposes of resale.
3. All components are covered by this limited warranty except expendable items, such as evaporative pads, media filter pads and nozzles.
4. If, within the warranty period, any Herrmidifier residential humidifier unit or component requires service, it must be performed by a competent heating and/or air conditioning contractor (preferably the installing contractor). CareCo will not pay shipping charges or labor charges to remove or replace such defective parts or components. If the part or component is found by inspection to contain such defective material and workmanship it will be either repaired or exchanged free of charge at CareCo's option, and returned freight collect.
5. In order to obtain the benefits of this limited two-year warranty, the owner must notify the dealer or distributor of any defect within 30 days of its discovery. If after reasonable time you have not received an adequate response from the dealer or distributor, notify in writing **CareCo Service Dept., 415 Wabash Ave., P.O. Box 200, Effingham, Illinois, 62401, or call 1-866-829-2440 or email fiacustomerservice@fedders.com**. Humidifiers which have been installed or become part of real estate cannot be returned. CareCo will receive, freight prepaid, only removable parts or components of such defective humidifiers.
6. This limited warranty does not apply to any part or component that is damaged in transit or in handling, has been subject to misuse, neglect or accident; has not been installed, operated and serviced according to Herrmidifier's instructions; has been operated beyond the factory rated capacity; or altered in any such way that its performance is affected. There is no warranty due to neglect, alteration or ordinary wear and tear. Herrmidifier's liability is limited to replacement of defective parts or components and does not include the payment of the cost of labor charges to remove or replace such defective components or parts.
7. CareCo will not be responsible for loss of use of any product; loss of time, inconvenience, or any other indirect, incidental or consequential damages with respect to person or property, whether as a result of breach of warranty, neglect or otherwise. SOME STATES DO NOT ALLOW THE EXCLUSION OR LIMITATION OF INCIDENTAL OR CONSEQUENTIAL DAMAGES, SO THE LIMITATION OR EXCLUSION IN THE PRECEDING SENTENCE MAY NOT APPLY TO YOU.
8. THIS WARRANTY GIVES YOU SPECIFIC RIGHTS, AND YOU MAY ALSO HAVE OTHER RIGHTS WHICH VARY FROM STATE TO STATE.
9. Any warranty by CareCo of merchantability, fitness for use or any other warranty (express, implied or statutory), representation or guarantee other than those set forth herein, shall expire at the expiration date of this express limited warranty. SOME STATES DO NOT ALLOW LIMITATIONS ON HOW LONG AN IMPLIED WARRANTY LASTS, SO THE LIMITATION IN THE PRECEDING SENTENCE MAY NOT APPLY TO YOU.
10. Herrmidifier reserves the right to make changes in the design and material of its products without incurring any obligation to incorporate such changes in units completed on the effective date of such change.

**CareCo Service Dept.,
415 Wabash Ave., P.O. Box 200, Effingham, Illinois, 62401
Phone: 1-866-829-2440
E-mail: fiacustomerservice@fedders.com**