

This Owner's Manual is provided and hosted by Appliance Factory Parts.

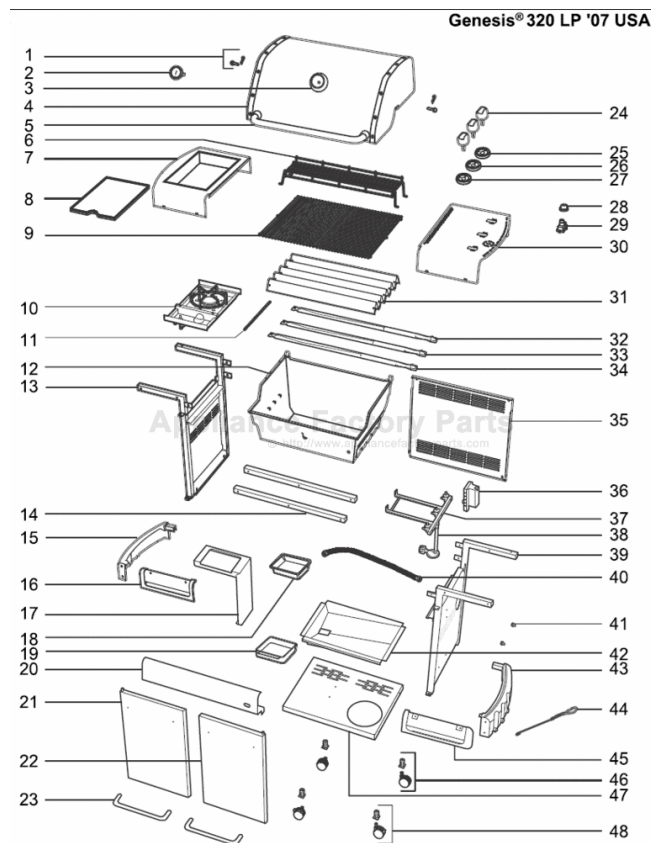

Weber GENESIS ESP-320 LP SS (2007) Owner's Manual

[Shop genuine replacement parts for Weber GENESIS
ESP-320 LP SS \(2007\)](#)



[Find Your Weber Grill Parts - Select From 2037 Models](#)

----- Manual continues below -----

GENESIS[®]

GAS GRILL

LP Gas Grill Owner's Guide

Guía del propietario del asador de gas licuado de propano - Pg 34

Guide de l'utilisateur du grill à gaz PL - Pg 34

E/S -310/320, EP -310/320

#89555

**YOU MUST READ THIS OWNER'S GUIDE
BEFORE OPERATING YOUR GAS GRILL**

⚠ DANGER

If you smell gas:

1. Shut off gas to the appliance.
2. Extinguish any open flames.
3. Open lid.
4. If odor continues, keep away from the appliance and immediately call your gas supplier or your fire department.

Leaking gas may cause a fire or explosion which can cause serious bodily injury or death, or damage to property.

⚠ WARNING: Follow all procedures carefully to barbecue operation. Barbecue was dealer.

NOTICE TO INSTALLER: Instructions must be left with the owner. Owner should keep them for future use.

**THIS GAS APPLIANCE IS FOR
OUTDOOR USE ONLY.**

⚠ WARNING: Do not try to operate the appliance without reading the "Instructions" section.

⚠ DANGER

Failure to follow the Dangers, Warnings and Cautions contained in this Owner's Manual may result in death, or in a fire or an explosion causing damage to property.

⚠ WARNINGS

- ⚠ Do not store a spare or disconnected liquid propane cylinder under or near this barbecue.
- ⚠ Improper assembly may be dangerous. Please follow the assembly instructions carefully.
- ⚠ After a period of storage, and/or nonuse, the Weber® gas barbecue should be checked for gas leaks before use. See instructions in this manual for correct procedures.
- ⚠ Do not operate the Weber® gas barbecue if there is a gas leak present.
- ⚠ Do not use a flame to check for gas leaks.
- ⚠ Combustible materials should never be within 24 inches (61 cm) of the back or sides of your Weber® gas barbecue.
- ⚠ Do not put a barbecue cover or anything flammable on, or in the storage area under the barbecue.
- ⚠ Your Weber® gas barbecue should never be used by children. Accessible parts of the barbecue should be kept away from children while it is in use.
- ⚠ You should exercise reasonable care when operating your Weber® gas barbecue. It will be hot and should never be left unattended, or moved while in operation.
- ⚠ Should the burners go out while in operation, turn all gas valves off. Open the lid and wait five minutes before relighting, using the lighting instructions.
- ⚠ Do not use charcoal or lava rock in your Weber® gas barbecue.
- ⚠ Never lean over open grill or place hands or fingers on the front edge of the cooking box.
- ⚠ Should a grease fire occur, turn off all burners and leave lid closed until fire is out.
- ⚠ Do not enlarge valve orifices or burner ports when cleaning the valves or burners.
- ⚠ The Weber® gas barbecue should be thoroughly cleaned on a regular basis.
- ⚠ Liquid propane gas is not natural gas. The conversion or attempted use of natural gas in a liquid propane gas unit is dangerous and will void your warranty.
- ⚠ Do not attempt to disconnect any gas fitting while your barbecue is in operation.
- ⚠ Use heat-resistant barbecue mitts or gloves when operating barbecue.
- ⚠ Keep any electrical supply cord and the fuel supply hose away from any heated surfaces.
- ⚠ Combustion byproducts produced when using this product contain chemicals known to the State of California to cause birth defects, or other reproductive harm.
- ⚠ Do not use this barbecue unless all parts are in place. The unit must be properly assembled according to the instructions.

LIQUID PROPANE GAS UNITS ONLY:

- ⚠ Use the pressure regulator and hose assembly that is supplied with your Weber® gas barbecue.
- ⚠ Do not attempt to disconnect the gas regulator and hose assembly or any gas fitting while your barbecue is in operation.
- ⚠ A dented or rusty liquid propane cylinder may be hazardous and should be checked by your local fire department. Do not use a liquid propane cylinder with a damaged valve.
- ⚠ Although your liquid propane cylinder may appear to be empty, gas may still be present, and should be transported and stored accordingly.
- ⚠ If you see, smell or hear the hiss of escaping gas from the liquid propane cylinder:
 1. Move away from liquid propane cylinder.
 2. Do not attempt to correct the problem yourself.
 3. Call your fire department.

WARRANTY, GARANTÍA, GARANTIE

Weber-Stephen Products Co. (Weber) hereby warrants to the ORIGINAL PURCHASER of this Weber® gas grill that it will be free of defects in material and workmanship from the date of purchase as follows:

Aluminum castings -2 year on paint excludes fading,	25-years
Stainless steel Shroud,	25-years
Porcelain-enameled shroud,	25-years
Cookbox Assembly -2 year on paint excludes fading,	10-years
Stainless steel burners tubes,	10-years
Stainless steel cooking grates,	5-years no rust through or burn through
Stainless steel Flavorizer bars,	5-years no rust through or burn through
Porcelain-enameled cast-iron cooking grates,	5-year no rust through or burn through
Porcelain-enameled cooking grates,	3-years no rust through or burn through
Porcelain-enameled Flavorizer bars,	2-years no rust through or burn through
Infrared Rotisserie Burner,	2-years
All remaining parts,	2-years

When assembled and operated in accordance with the printed instructions accompanying it. Weber may require reasonable proof of your date of purchase. THEREFORE, YOU SHOULD RETAIN YOUR SALES SLIP OR INVOICE.

This Limited Warranty shall be limited to the repair or replacement of parts that prove defective under normal use and service and which on examination shall indicate, to Weber's satisfaction, they are defective. Before returning any parts, contact the Customer Service Representative in your area using the contact information on our website. If Weber confirms the defect and approves the claim, Weber will elect to replace such parts without charge. If you are required to return defective parts, transportation charges must be prepaid. Weber will return parts to the purchaser, freight or postage prepaid.

Weber-Stephen Products Co., (Weber) mediante la presente le garantiza al COMPRADOR ORIGINAL de esta barbacoa de gas Weber® que la misma estará libre de defectos en cuanto a materiales y fabricación a partir de la fecha de compra según lo siguiente:

Piezas coladas de aluminio-2 años para la pintura excluyendo la decoloración,	25-años
Cubierta de acero inoxidable,	25-años
Cubierta porcelanizada,	25-años
Cámara para aser-2 años para la pintura excluyendo la decoloración,	10-años
Tubos de acero inoxidable de los quemadores,	10-años
Parrillas de cocción de acero inoxidable,	5-años sin perforación por fuego u oxidación
Baras Flavorizer de acero inoxidable,	5-años sin perforación por fuego u oxidación
Parrillas de cocción de hierro esmaltado porcelanizado,	5-años sin perforación por fuego u oxidación
Parrillas de cocción porcelanizadas,	3-años sin perforación por fuego u oxidación
Baras Flavorizer porcelanizadas,	2-años sin perforación por fuego u oxidación
Quemador infrarrojo del asador giratorio,	2-años
Todas la demás partes,	2-años

cuando se ensambla y opera de acuerdo a las instrucciones impresas que la acompañan. Weber pudiese requerir prueba razonable de la fecha de compra. POR LO TANTO, DEBERÁ GUARDAR SU RECIBO O FACTURA DE VENTA.

Esta garantía limitada está limitada a la reparación o reemplazo de piezas que resultasen defectuosas bajo uso y servicio normal y las cuales al examinarse indiquen, a plena satisfacción de Weber, que efectivamente son piezas defectuosas. Antes de devolver cualquier parte, contacte al Representante de Atención al Cliente en su área, cuya información de contacto la encontrará en nuestro sitio web. Si Weber confirma el defecto y aprueba el reclamo, ésta elegirá reparar o reemplazar tal pieza sin cargo alguno. Si usted tiene que retornamos las partes defectuosas, los gastos de transporte deben ser

Weber-Stephen Products Co. (Weber) garantit par le présent document à l'ACHETEUR D'ORIGINE de ce grill à gaz Weber® que celui-ci ne comportera aucun défaut de pièce ni de main d'oeuvre à compter de la date d'achat comme suit :

Fonte d'aluminium (2 ans pour la peinture à l'exception de toute décoloration),	25 ans
Structure en acier inoxydable,	25 ans
Structure émaillée,	25 ans
Cuve (2 ans pour la peinture à l'exception de toute décoloration),	10 ans
Tubes du brûleur en acier inoxydable,	10 ans

This Limited Warranty does not cover any failures due to misuse, alteration, misapplication, vandalism, improper service, or failure to perform normal and routine maintenance caused by insects within the burner tubes, as set forth. Deterioration or damage due to severe weather conditions or tornadoes, discoloration due to exposure to chemicals not covered by this Limited Warranty.

There are no other express warrants except as set forth. The implied warranties of merchantability and fitness are limited in duration by this Limited Warranty. Some regions do not allow limitation of the implied warranty. This limitation may not apply to you.

Weber is not liable for any special, indirect or consequential damages, or exclusion or limitation of incidental or consequential damages that may apply to you.

Weber does not authorize any person or company to make any representation in connection with the sale, installation, use, removal, or return of the grill. Such representations are binding on Weber.

This Warranty applies only to products sold at retail prices.

WEBER-STEPHEN PRODUCTS CO.
Customer Service Center
1890 Roselle Road, Suite 308
Schaumburg, IL 60195
USA

For replacement parts call:

1-800-446-1071
www.weber.com

prepagados. Weber retomará las partes al comprador. Esta Garantía Limitada no cubre ninguna falla o deterioro causado por abuso, mal uso, alteración, uso en aplicaciones no autorizadas, mantenimiento o servicio inapropiados, o por no seguir las instrucciones entre los que se incluyen, pero sin limitación, los quemadores, según se detalla en este manual de instrucciones. Esta Garantía Limitada no cubre el deterioro o daño causado por tales como granizo, huracanes, terremotos o tornados, sustancias químicas bien sea por contacto directo.

No existe ninguna otra garantía expresa que no sea implícitas de comerciabilidad y aptitud de uso establecidas por esta expresa Garantía Limitada por escrito. Aunque el tiempo que una garantía implícita pueda durar, por el presente Weber no se hace responsable de cualesquier daños o lesiones que en algunas regiones no permiten la exclusión o limitación de la garantía o exclusión pudieran no aplicarle a usted. Weber no autoriza a persona o empresa alguna a hacer cualquier representación en relación con la venta, instalación, uso, mantenimiento, o reparación de los equipos, y ninguna tal representación será vinculante. Esta Garantía aplica solo a aquellos productos vendidos al público.

WEBER-STEPHEN PRODUCTS CO.
Customer Service Center
1890 Roselle Road, Suite 308
Schaumburg, IL 60195
USA

Para partes de repuesto llame a:

1-800-446-1071
www.weber.com

La présente Garantie limitée ne couvre pas toute détérioration ou dommage résultant de l'accident, une utilisation abusive, une mauvaise utilisation, un acte de vandalisme, une installation incorrecte ou l'absence d'entretien normal et régulier, y compris les dommages causés par les insectes à l'intérieur des tubes du brûleur, tel que mentionné. Toute détérioration ou tout dommage résultant de conditions météorologiques extrêmes, des ouragans, des séismes ou des tornades, des agents chimiques directement ou dans l'atmosphère n'est pas couverte par la présente Garantie limitée.

Il n'existe aucune autre garantie expresse homologue.

VISION ÉCLATÉE, DIAGRAMA DE DESPIECE

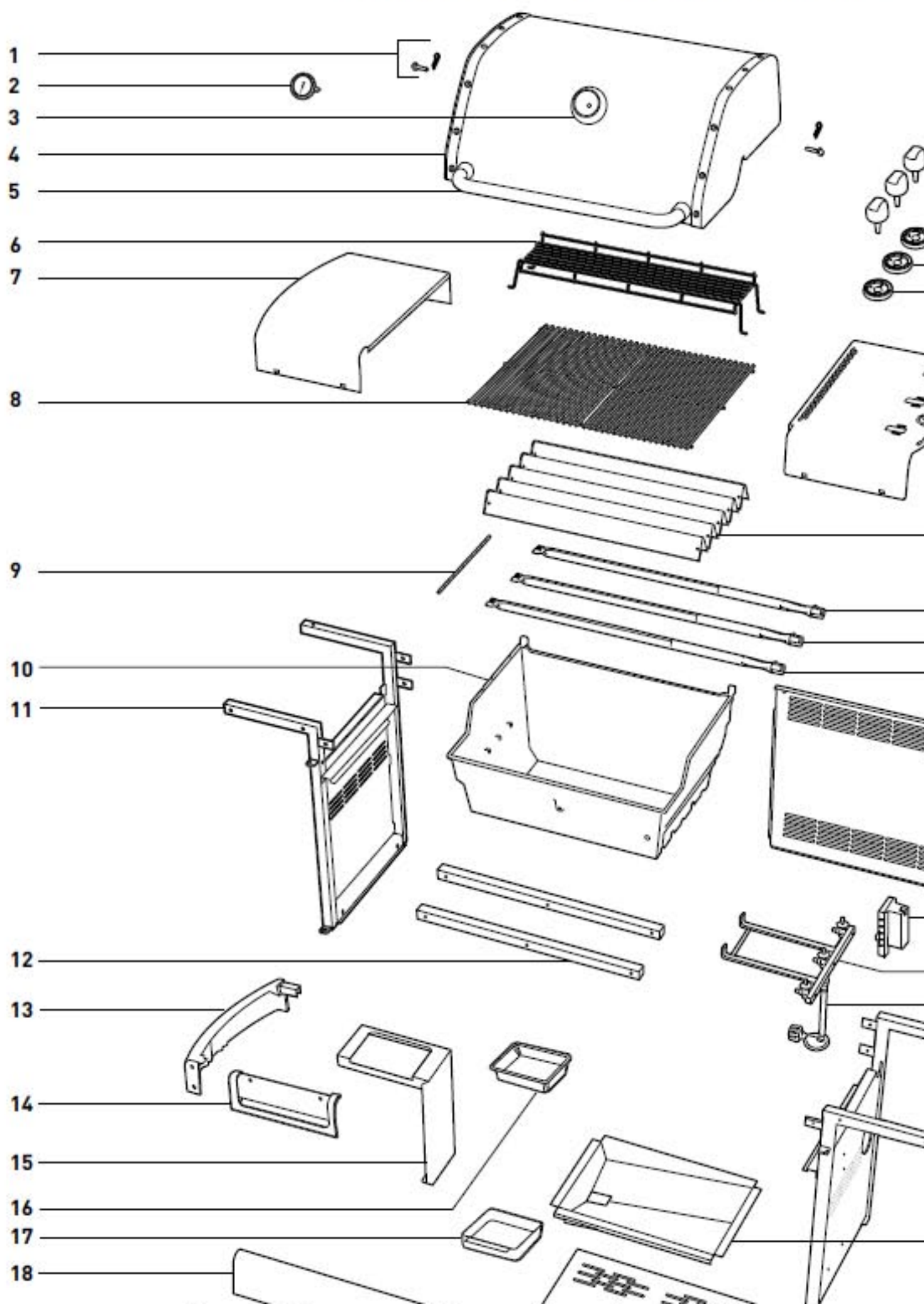

LISTA DEL DIAGRAMA DE DESPIECE, LISTE DE LA VISION É

- | | | |
|--|---|---------------------------------|
| 1. Shroud Hardware
Accesorios de la cubierta
Structure de protection | 18. Front Panel
Panel frontal
Panneau avant | 35. Mar
Múlt
Coll |
| 2. Thermometer
Termómetro
Thermomètre | 19. Left Door
Puerta izquierda
Porte gauche | 36. Hos
Ma
Tuya |
| 3. Thermometer Bezel
Moldura decorativa del termómetro
Plaque indicatrice du thermomètre | 20. Right Door
Puerta derecha
Porte droite | 37. Righ
Pan
Pan |
| 4. Shroud
Cubierta
Tôle de protection | 21. Door Handle
Asa de la puerta
Poignée de porte | 38. Tan
Des
Gliss |
| 5. Handle
Asa
Poignée | 22. Control Knob
Perilla de control
Bouton de commande | 39. Drip
Ban
Ego |
| 6. Warming Rack
Rejilla de calentamiento
Grille de réchauffage | 23. Bezel #3
Moldura decorativa #3
Plaque indicatrice N° 3 | 40. Righ
Piez
Pièc |
| 7. Left Side Table
Mesa lateral izquierda
Tablette latérale gauche | 24. Bezel #2
Moldura decorativa #2
Plaque indicatrice N° 2 | 41. Mat
Port
Port |
| 8. Cooking Grates
Parrillas de cocción
Grilles de cuisson | 25. Bezel #1
Moldura decorativa #1
Plaque indicatrice N° 1 | 42. Righ
Piez
Pièc |
| 9. Crossover® Tube
Tubo Crossover®
Tuyau Crossover® | 26. Igniter Button
Botón de encendido
Bouton d'allumage | 43. Cas
Rue
Rou |
| 10. Cookbox
Caja de cocción
Boîtier de cuisson | 27. Igniter Module
Módulo de encendido
Module d'allumage | 44. Bot
Pan
Pan |
| 11. Left Frame Panel
Panel izquierdo del bastidor
Panneau du cadre gauche | 28. Right Side Table
Mesa lateral derecha
Tablette latérale droite | 45. Loc
Rue
Rou |
| 12. Frame Support
Soporte del bastidor
Support de cadre | 29. Flavorizer® Bar
Barra Flavorizer®
Barre Flavorizer® | |
| 13. Left Trim Piece
Pieza de guarnición izquierda
Pièce de garniture gauche | 30. Rear Burner Tube
Tubo quemador posterior
Tube du brûleur arrière | |
| 14. Left Front Trim Piece
Pieza de guarnición frontal izquierda
Pièce de garniture avant gauche | 31. Middle Burner Tube
Tubo quemador del medio
Tube du brûleur du milieu | |

VISION ÉCLATÉE, DIAGRAMA DE DESPIECE

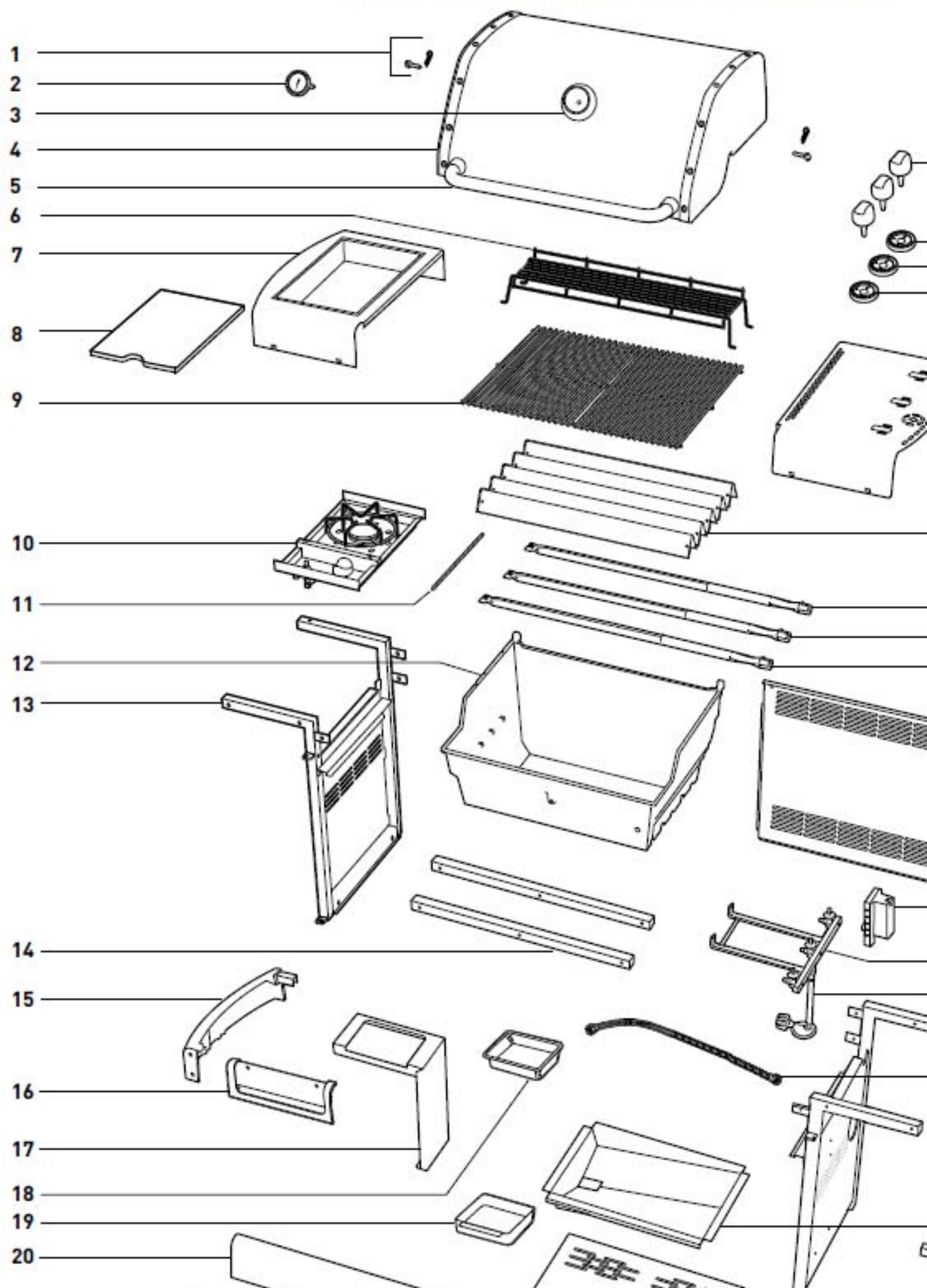

LISTA DEL DIAGRAMA DE DESPIECE, LISTE DE LA VISION É

- | | | |
|---|--|--|
| 1. Shroud Hardware
Accesorios de la cubierta
Structure de protection | 18. Disposable Drip Pan
Bandeja de goteo desechable
Egouttoir jetable | 35. Back Panel
Panel trasero
Panneau arrière |
| 2. Thermometer
Termómetro
Thermomètre | 19. Catch Pan
Plato recolector
Egouttoir | 36. Top Panel
Panel superior
Plaque supérieure |
| 3. Thermometer Bezel
Moldura decorativa del termómetro
Plaque indicatrice du thermomètre | 20. Front Panel
Panel frontal
Panneau avant | 37. Main Control Panel
Panel de control principal
Tablette de commande |
| 4. Shroud
Cubierta
Tôle de protection | 21. Left Door
Puerta izquierda
Porte gauche | 38. Hot Gas Inlet
Entrada de gas caliente
Tuyau d'entrée des gaz chauds |
| 5. Handle
Asa
Poignée | 22. Right Door
Puerta derecha
Porte droite | 39. Right Side Panel
Panel lateral derecho
Panneau latéral droit |
| 6. Warming Rack
Rejilla de calentamiento
Grille de réchauffage | 23. Door Handle
Asa de la puerta
Poignée de porte | 40. Main Control Panel
Panel de control principal
Tablette de commande |
| 7. Side Burner Table
Mesa del quemador lateral
Tablette du brûleur latéral | 24. Control Knob
Perilla de control
Bouton de commande | 41. Top Panel
Panel superior
Plaque supérieure |
| 8. Side Burner Lid
Tapa del quemador lateral
Couvercle du brûleur latéral | 25. Bezel #3
Moldura decorativa #3
Plaque indicatrice N° 3 | 42. Drip Pan
Bandeja de goteo
Egouttoir |
| 9. Cooking Grates
Parrillas de cocción
Grilles de cuisson | 26. Bezel #2
Moldura decorativa #2
Plaque indicatrice N° 2 | 43. Right Side Panel
Panel lateral derecho
Panneau latéral droit |
| 10. Side Burner
Quemador lateral
Brûleur latéral | 27. Bezel #1
Moldura decorativa #1
Plaque indicatrice N° 1 | 44. Main Control Panel
Panel de control principal
Tablette de commande |
| 11. Crossover Tube
Tubo Crossover
Tuyau Crossover | 28. Igniter Button
Botón de encendido
Bouton d'allumage | 45. Right Side Panel
Panel lateral derecho
Panneau latéral droit |
| 12. Cookbox
Caja de cocción
Boîtier de cuisson | 29. Igniter Module
Módulo de encendido
Module d'allumage | 46. Cookbox
Caja de cocción
Boîtier de cuisson |
| 13. Left Frame Panel
Panel izquierdo del bastidor
Panneau du cadre gauche | 30. Right Side Table
Mesa lateral derecha
Tablette latérale droite | 47. Bottom Panel
Panel inferior
Panneau inférieur |
| 14. Frame Support
Soporte del bastidor
Support de cadre | 31. Flavorizer® Bar
Barra Flavorizer®
Barre Flavorizer® | 48. Location
Rueda de localización
Roue de positionnement |

Your Weber® gas barbecue is a portable outdoor cooking appliance. With the Weber® gas barbecue you can grill, barbecue, roast and bake with results that are difficult to duplicate with indoor kitchen appliances. The closed lid and Flavorizer® Bars produce that "outdoor" flavor in the food.

The Weber® gas barbecue is portable so you can easily change its location in your yard or on your patio. Portability means you can take your Weber® gas barbecue with, if you move.

Liquid Propane (LP) gas supply is easy to use and gives you more cooking control than charcoal fuel.

- These instructions will give you the minimum requirements for assembling your Weber® gas barbecue. Please read the instructions carefully before using your Weber® gas barbecue. Improper assembly can be dangerous.
- Not for use by children.
- If there are local codes that apply to portable gas grills, you will have to conform to them. Installation must conform with local codes or, in the absence of local codes, with either the National Fuel Gas Code, ANSI Z223.1/NFPA 54, Natural Gas and Propane Installation Code, CSA B149.1, or Propane Storage and Handling Code, B149.2, or the Standard for Recreational Vehicles, ANSI A 119.2/NFPA 1192, and CSA Z240 RV Series, Recreational Vehicle Code, as applicable.
- The pressure regulator supplied with the Weber® gas barbecue must be used. This regulator is set for 11 inches of water column (pressure).
- This Weber® gas barbecue is designed for use with liquid propane (LP) gas only. Do not use with natural (piped in city) gas. The valves, orifices, hose and regulator are for LP gas only.
- Do not use with charcoal fuel.
- Check that the area under the control panel and the bottom tray are free from debris that might obstruct the flow of combustion or ventilation air.
- The areas around the LP cylinder must be free and clear from debris.
- Replacement pressure regulators and hose assemblies must be those specified by Weber-Stephen Products Co.

FOR INSTALLATION IN CANADA

These instructions, while generally acceptable, do not necessarily comply with the Canadian Installation codes, particularly with piping above and below ground. In Canada the installation of this appliance must comply with local codes and/or Standard CSA-B149.2 (Propane Storage and Handling Code).

OPERATING

- ⚠ **WARNING: Only use this barbecue outdoors in a well-ventilated area. Do not use in a garage, building, breezeway or any other enclosed area.**
- ⚠ **WARNING: Keep ventilation openings for cylinder enclosure free and clear from debris.**

- ⚠ **WARNING: Your Weber® gas barbecue should not be used under overhead combustible materials.**
- ⚠ **WARNING: Your Weber® gas barbecue should not be installed in or on recreational vehicles.**
- ⚠ **WARNING: Do not use the barbecue for drying or burning combustible materials to the point of ignition.**
- ⚠ **WARNING: The entire cooking area should not be left unattended.**
- ⚠ **WARNING: Keep any electrical wiring and supply hose away from any heat source.**
- ⚠ **WARNING: Keep the cooking area free of grease and liquids such as gasoline and oil.**
- ⚠ **WARNING: Never store an LP cylinder near the Weber® gas barbecue.**
- ⚠ **WARNING: The LP cylinder must be with a listed OPD (Overhead Protection Device) or a QCC1 or Type 1 (CGA810) cylinder connection must be used for the connection.**

STORAGE AND/OR NONUSE

- The gas must be turned off at the liquid propane cylinder when the barbecue is not in use.
- When the Weber® gas barbecue is stored, the LP cylinder must be DISCONNECTED and the LP cylinder must be stored outdoors in a well-ventilated area. A disconnected LP cylinder must not be stored in an enclosed area.
- When the LP cylinder is not disconnected from the barbecue, the appliance and LP tank must be kept outdoors.
- The Weber® gas barbecue should be cleaned after each use. Burner tubes before using. (See Section: "Maintenance/Annual Maintenance")
- Check that the areas under the control panel and the bottom tray are free from debris that might obstruct the flow of combustion or ventilation air.
- The Spider /Insect Screens should also be cleaned after each use. (See Section: "Maintenance/Annual Maintenance")

COOKING

- ⚠ **WARNING: Do not move the Weber® gas barbecue when operating or while barbecue is hot.**

You can adjust BURNER 1, 2, and 3 as desired. The control settings: High (H), Medium (M), Low (L), or Off (O) are described in your Weber® cookbook. The cookbook uses these notations to describe the settings of BURNER 1, 2, and 3. For example, to sear steaks, you would set all burners at H (high). Then to complete cooking, you would set BURNER 1 and BURNER 3 at M (medium). Refer to your Weber® cookbook for detailed cooking instructions.

Note: The temperature inside your cooking box for the first few uses, while surfaces are still very reflective, may be hotter than those shown in your cookbook. Cooking conditions such as wind and weather, may require the adjustment of the burner controls to obtain the correct cooking temperatures.

- ⚠ **WARNING: Check the bottom tray after each use. Remove excess grease and the slide out bottom tray.**

CLEANING

- ⚠ **WARNING: Turn your Weber® gas barbecue off and allow it to cool before cleaning.**
- ⚠ **CAUTION: Do not clean your grill grates in a self-cleaning oven.**

For availability of replacement cooking...

GENERAL INSTRUCTIONS

Slide out Bottom tray - Remove excess grease, then wash with warm soapy water, then rinse.

Flavorizer® bars and Cooking grates - Clean with a suitable brass bristle brush. As needed, remove from grill and wash with warm soapy water, then rinse with water.

Catch pan - Disposable foil trays are available, or you can line the catch pan with aluminum foil. To clean the catch pan, wash with warm soapy water, then rinse.

Thermometer - Wipe with warm soapy water; clean with plastic scrub ball.

Inside cooking module - Brush any debris off of burner tubes. **DO NOT ENLARGE BURNER PORTS (OPENINGS)**. Wash inside of cooking box with warm soapy water and a water rinse.

Inside Lid - While lid is warm, wipe inside with paper towel to prevent grease build-up. Flaking built-up grease resembles paint flakes.

Stainless steel surfaces - Wash with a soft cloth and a soap and water solution. Be careful to scrub with the grain direction of the stainless steel.

Do not use cleaners that contain acid, mineral spirits or xylene. Rinse well after cleaning.

Preserve Your Stainless Steel

Your grill or its cabinet, lid, control panel and burners are made of stainless steel. To keep the stainless steel looking its best, wash with warm soapy water, rinse with clear water and wipe dry. A stainless steel or nylon metallic brush can be used.

⚠ IMPORTANT: Do not use a wire brush on the stainless steel surface to remove scratches.

⚠ IMPORTANT: When cleaning, always scrub in the direction of the grain to prevent scratches in the steel.

GAS INSTRUCTIONS

IMPORTANT LP CYLINDER INFORMATION

Failure to follow these **DANGER** statements exactly may result in a fire causing death or serious injury.

⚠ DANGER

⚠ NEVER store a spare LP Cylinder under or near this barbecue.

⚠ NEVER fill the tank beyond 80% full.

Your Weber® gas grill is equipped for a cylinder supply system designed for vapor withdrawal.

⚠ WARNING: Only use this grill outdoors in a well-ventilated area. Do not use in a garage, building, breezeway or any other enclosed area.

The proper filling methods for the filling of LP cylinders are described in NFPA 58. Please make sure you are filling to the correct weight or volume. Ask your filling station for the correct LP cylinder before attempting to fill.

LEAK CHECK PREPARATION

CHECK THAT ALL BURNER VALVES

Valves are shipped in the "OFF" position. Check by pushing down and turning clockwise. Proceed to the next step. If they do not turn, stop, then they are off. Proceed to the next step.

CONNECTING THE LIQUID PROPANE CYLINDER

All Weber® liquid propane gas grill regulators are equipped with a UL-listed tank connection as per the latest edition of ANSI Z21.58. This will require a liquid propane tank that is similarly equipped with a Type 1 connection in the tank valve. This Type 1 coupling allows you to make a fast and totally safe hookup between your gas grill and your liquid propane tank. It eliminates the chance of leaks due to a POL fitting that is not properly tightened. Gas will not flow from the tank unless the Type 1 coupling is fully engaged into the coupling.

⚠ WARNING: Make sure that the LP cylinder valve is closed. Close by turning valve clockwise.

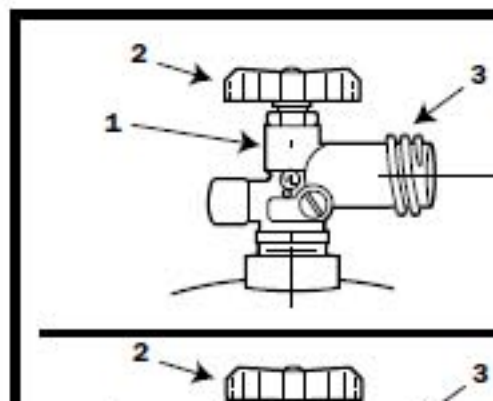

To Connect the hose to the cylinder:

- 1) Pass the regulator hose through the side panel opening to the inside of the base cabinet.

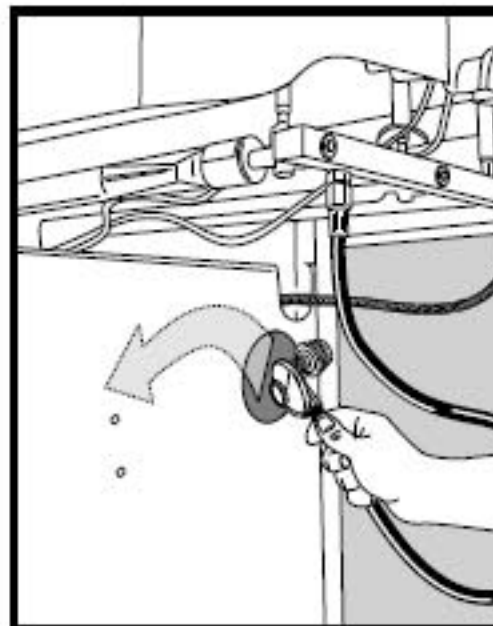

- 2) Locate hose retention clip (a) on regulator hose. Secure into slot (b) on underside of tank scale.

⚠ WARNING: The hose must be secured to the tank scale with the Hose Retention Clip. Failure to do so could cause damage to the hose resulting in a fire or explosion which can cause serious bodily injury or death, and damage to property.

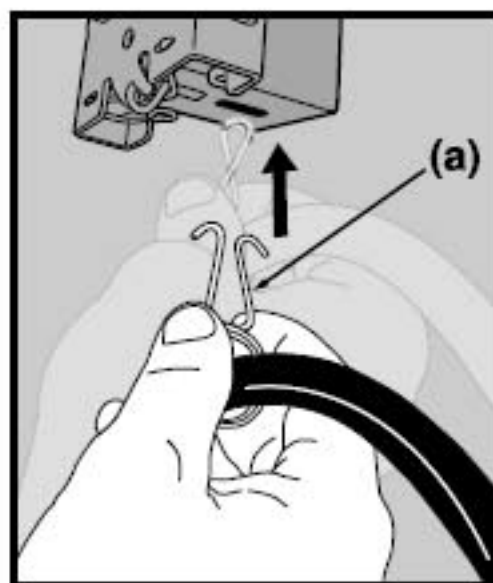

The LP cylinder is installed inside the base cabinet, on the tank scale (right side).

- 3) Open base cabinet doors.
- 4) Turn the LP cylinder so the opening of the valve is either to the front, side or rear of the Weber® gas barbecue. Lift and hook the cylinder onto the fuel gauge.
- 5) Lift tank up into position on the tank scale.
- 6) Loosen the cylinder lock wing nut. Swing the cylinder lock down. Tighten the wing nut.

Some LP tanks have differing top collar assemblies. (The top collar is the metal protective ring around the valve.) One series of tanks mount with the valve facing front (a). The other tanks mount with the valve facing away from the fuel scale (b). Weber recommends the use of cylinder manufacturer's Manchester and Worthington, with a 47.6 lb water capacity. Other cylinders may be acceptable for use with the appliance provided they are compatible with the appliance retention means (see illustrations).



- 7) Remove the plastic dust cover from the valve.
- 8) Screw the regulator coupling onto the tank valve, clockwise, or to the right. Hand-tighten only.

Note: This is a new type of connection. It tightens clockwise and will not allow gas to flow unless the connection is tight. The connection requires tightening by hand only.

⚠ WARNING: Do not use a wrench to tighten the connection. Using a wrench could damage the regulator coupling and



GAS INSTRUCTIONS

REMOVE CONTROL KNOBS & CONTROL PANEL FOR LEAK TESTING

You will need: Phillips screwdriver.

- 1) Remove control knobs.
- 2) Remove screw and washer from back of control panel with a Phillips screwdriver.
- 3) Tilt the back edge of the control panel up. Push in on the front edge to release locking tabs. Carefully pull control panel away from frame.
- 4) Disconnect the igniter wires from the ignition module.
- 5) Replace control panel when Leak Check is completed.

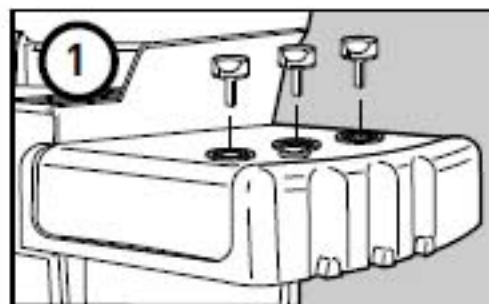

CHECK FOR GAS LEAKS

⚠ DANGER

Do not use an open flame to check for gas leaks. Be sure there are no sparks or open flames in the area while you check for leaks. Sparks or open flames will result in a fire or explosion, which can cause serious bodily injury or death and damage to property.

⚠ WARNING: You should check for gas leaks every time you disconnect and reconnect a gas fitting.

Note: All factory-made connections have been thoroughly checked for gas leaks. The burners have been flame-tested. As a safety precaution however, you should recheck all fittings for leaks before using your Weber® Gas Barbecue. Shipping and handling may loosen or damage a gas fitting.

⚠ WARNING: Perform these leak checks even if your barbecue was dealer or store assembled.

You will need: a soap and water solution, and a rag or brush to apply it.

Note: Since some leak test solutions, including soap and water, may be slightly corrosive, all connections should be rinsed with water after checking for leaks.

If your grill has a side burner make sure the side burner is off.

To perform leak checks: open cylinder valve by turning the cylinder valve hand-wheel counterclockwise.

⚠ WARNING: Do not ignite burners when leak checking.

Check for leaks by wetting the connections with the soap and water solution and watching for bubbles. If bubbles form or if a bubble grows, there is a leak.

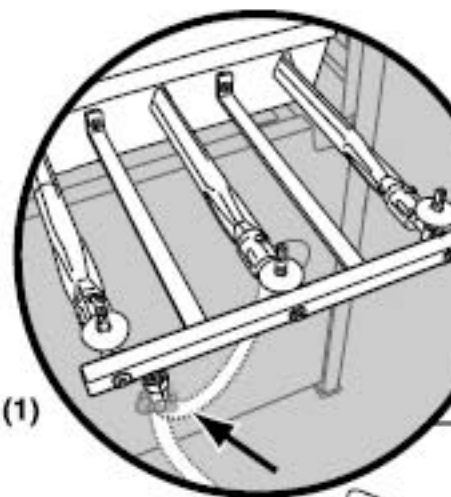

Check:

- 1) Hose-to-manifold connection.

⚠ WARNING: If there is a leak at connection (1), retighten the fitting with a wrench and recheck for leaks with soap and water solution. If a leak persists after retightening the fitting, turn OFF the gas. DO NOT OPERATE THE GRILL. Contact the Customer Service Representative in your area using the contact information on our web site. Log onto www.weber.com.

- 2) Regulator-to-Cylinder connection.



Check:

- 1) Hose to manifold connection.
- 2) Side burner hose to manifold connection and side burner hose to side burner gas line connection.
- 3) Side burner hose to side burner connection, side burner valve and orifice connections.

⚠ WARNING: If there is a leak at connection (1, 2, or 3), retighten the fitting with a wrench and recheck for leaks with soap and water solution. If a leak persists after re-tightening the fitting, turn **OFF** the gas. **DO NOT OPERATE THE GRILL.** Contact the Customer Service Representative in your area using the contact information on our web site. Log onto www.weber.com®.

- 4) Regulator to cylinder connection.
- 5) Hose to regulator connection.
- 6) Valves to manifold connections.

⚠ WARNING: If there is a leak at connections (4, 5 or 6), turn **OFF** the gas. **DO NOT OPERATE THE GRILL.** Contact the Customer Service Representative in your area using the contact information on our web site. Log onto www.weber.com®.

When leak checks are complete, turn gas supply **OFF** at the source and rinse connections with water.

REFILLING THE LIQUID PROPANE CYLINDER

We recommend that you refill the LP cylinder before it is completely empty.

Removal of the LP cylinder

- 1) Close cylinder valve (turn clockwise).
- 2) Unscrew regulator coupling by turning counterclockwise, by hand only.
- 3) Loosen cylinder lock wing nut and turn cylinder lock up out of the way.
- 4) Lift cylinder off.

To fill, take the LP cylinder to a gas propane dealer, or look up "gas-propane" in the phone book for other sources of LP gas.

⚠ WARNING: We recommend that your LP cylinder be filled at an authorized LP gas dealer, by a qualified attendant, who fills the cylinder by weight. **IMPROPER FILLING IS DANGEROUS.**

⚠ CAUTION: Place dust cap on cylinder valve outlet whenever the cylinder is not in use. Only install the type of dust cap on the cylinder valve outlet that is provided with the cylinder valve. Other types of caps or plugs may result in leakage of propane.

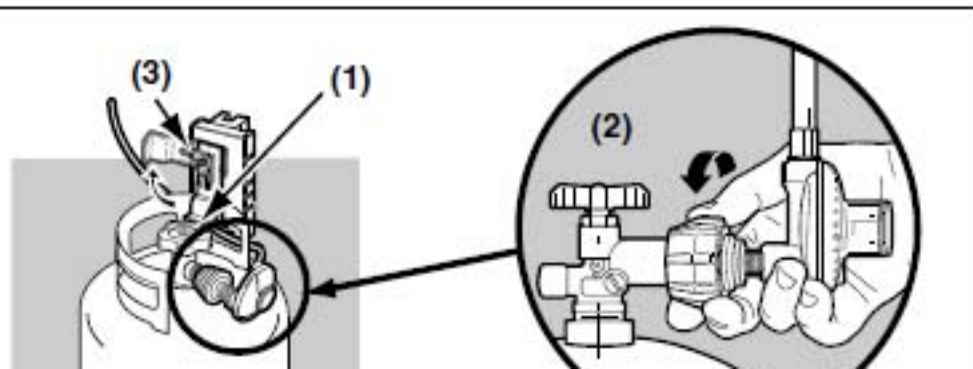
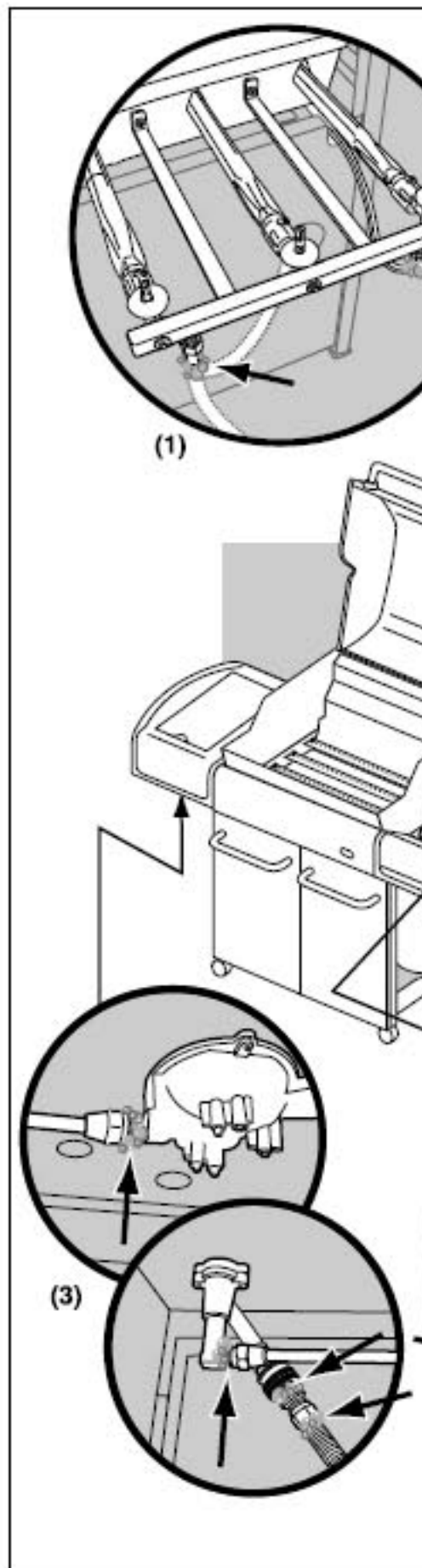

GAS INSTRUCTIONS

SAFE HANDLING TIPS FOR LIQUID PROPANE GAS CYLINDERS

- Liquid Propane (LP) gas is a petroleum product as are gasoline and natural gas. LP gas is a gas at regular temperatures and pressures. Under moderate pressure, inside a cylinder, LP gas is a liquid. As the pressure is released, the liquid readily vaporizes and becomes gas.
- LP gas has an odor similar to natural gas. You should be aware of this odor.
- LP gas is heavier than air. Leaking LP gas may collect in low areas and prevent dispersion.
- To fill, take the LP cylinder to a gas propane dealer, or look up "gas-propane" in the phone book for other sources of LP gas.

⚠ WARNING: We recommend that your LP cylinder be filled at an authorized LP gas dealer, by a qualified attendant, who fills the tank by weight. IMPROPER FILLING IS DANGEROUS.

- Air must be removed from a new LP cylinder before the initial filling. Your LP dealer is equipped to do this.
- The LP cylinder must be installed, transported and stored in an upright position. LP cylinders should not be dropped or handled roughly.
- Never store or transport the LP cylinder where temperatures can reach 125° F (too hot to hold by hand - for example: do not leave the LP cylinder in a car on a hot day).

Note: A refill will last about 18-20 hours of cooking time at normal use. The fuel scale will indicate the propane supply so you can refill before running out. You do not have to run out before you refill.

- Treat "empty" LP cylinders with the same care as when full. Even when the LP tank is empty of liquid there still may be gas pressure in the cylinder. **Always close the cylinder valve before disconnecting.**

⚠ CAUTION: Place dust cap on cylinder valve outlet whenever the cylinder is not in use. Only install the type of dust cap on the cylinder valve outlet that is provided with the cylinder valve. Other types of caps or plugs may result in leakage of propane.

- Do not use a damaged LP cylinder. Dented or rusty LP cylinders or LP cylinders with a damaged valve may be hazardous and should be replaced with a new one immediately.

Liquid Propane (LP) Cylinder(s)

- The joint where the hose connects to the LP cylinder must be leak tested each time the LP cylinder is reconnected. For example, test each time the LP cylinder is refilled.
- Be sure the regulator is mounted with the small vent hole pointed downward so that it will not collect water. This vent should be free of dirt, grease, bugs etc.
- The gas connections supplied with your Weber® gas barbecue have been designed and tested to meet 100% CSA and ANSI requirements.

⚠ WARNING: Replacement LP tanks must match the regulator connection supplied with this barbecue.

Liquid Propane Cylinder requirements

- Check to be sure cylinders have a D.O.T. stamp within five years. Your LP gas supplier can help.
- All LP tank supply systems must include a flashback arrestor.
- The LP cylinder must be a 20-lb. size (14" in diameter).
- The cylinder should be constructed according to the Specifications for LP - Gas Cylinders (D.O.T.) or the National Standard of Containers and Tubes or Transportation of Dangerous Goods.

In Canada

Liquid Propane Cylinder requirements

Note: Your retailer can help you match a cylinder to your equipment.

- The LP cylinder must be constructed according to the specifications for LP gas cylinders, T.C. 113.

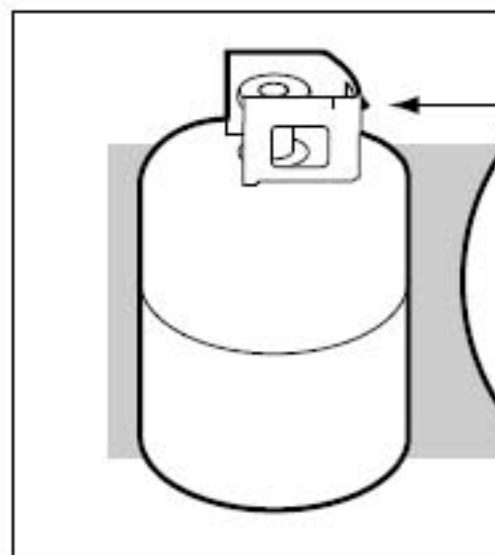

OPERATING INSTRUCTIONS

LIGHTING

Summary lighting instructions are inside the left hand cabinet door.

⚠ DANGER

Failure to open the lid while igniting the barbecue's burners, or not waiting 5 minutes to allow the gas to clear if the barbecue does not light, may result in an explosive flame-up

Crossover® Ignition System

Note: The Crossover® Ignition System ignites the spark electrode inside the Gas Catcher™ ignition by pushing the electronic ignition button.

⚠ WARNING: Check hose before use for cracking, abrasions or cuts. If damaged in any way, do not use the barbecue. Replace with a Weber® authorized replacement hose.

MAIN BURNER LIGHTING

- 1) Open the lid.
- 2) Make sure all burner control knobs are turned OFF. (Push control knob down and turn clockwise to ensure that it is in the OFF position.)

⚠ WARNING: The burner control knobs must be in the OFF position before turning on the liquid propane cylinder tank valve. If they are not in the OFF position, when you turn on the LP cylinder valve, the “excess gas flow control” feature will activate, limiting the flow of gas from the LP cylinder. If this should occur, turn OFF the LP cylinder valve and burner control knobs. Start over.

⚠ DANGER:

When the “excess gas flow control” feature is activated, a small amount of gas is still flowing to the burners. After turning OFF the cylinder valve, wait at least 5 minutes for the gas to clear before attempting to light the barbecue. Failure to do so may result in an explosive flame-up, which can cause serious bodily injury or death.

- 3) Turn the cylinder on by slowly turning the cylinder valve counterclockwise.

⚠ WARNING: Do not lean over the open barbecue. Keep your face and body at least one foot away from the matchlight hole when lighting the barbecue.

- 4) Push BURNER 1 control knob down and turn to START/HI.
- 5) Push the electronic ignition button several times. You will hear it spark.
- 6) Check that the burner is lit by looking through the matchlight hole on the front of the cooking box. You should see a flame.

⚠ WARNING: If the burner does not light, turn the Burner 1 control knob to OFF and wait 5 minutes to let the gas clear before you try again or try to light with a match.

- 7) After BURNER 1 is lit you can turn on BURNER 2 and BURNER 3.
- Note - Always light BURNER 1 first. The other burners ignite from BURNER 1.*

TO EXTINGUISH

Push down and turn each burner control knob clockwise to the OFF position. Turn gas supply OFF at the source.

MAIN BURNER MANUAL LIGHTING

⚠ DANGER

Failure to open the lid while igniting the barbecue’s burners, or not waiting 5 minutes to allow the gas to clear if the barbecue does not light, may result in an explosive flame-up which can cause serious bodily injury or death.

- 1) Open the lid.
- 2) Make sure all burner control knobs are turned OFF. (Push each knob down and turn clockwise to ensure they are in the “OFF” position.)

⚠ WARNING: The burner control knobs must be in the OFF position before turning on the liquid propane cylinder valve. If they are not in the OFF position, when you turn on the LP

MAIN BURNER LIGHTING

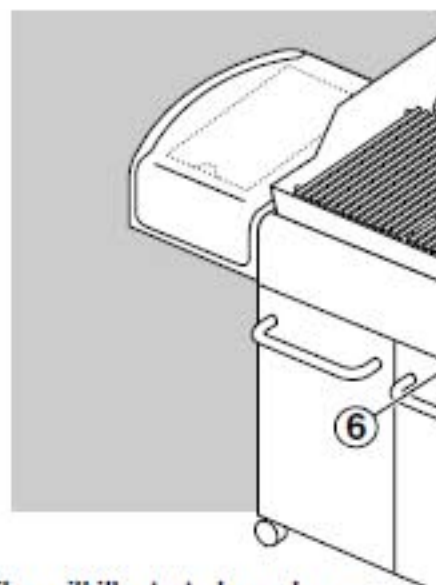
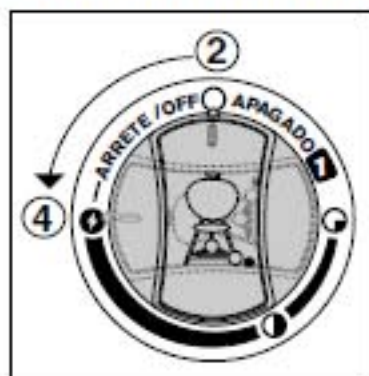

*The grill illustrated may have slight differences than the model purchased.

MAIN BURNER MANUAL LIGHTING

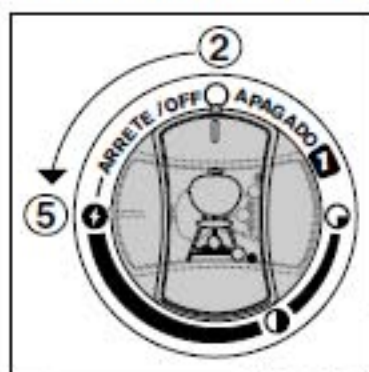

⚠ DANGER

When the "excess gas flow control" feature is activated, a small amount of gas is still flowing to the burners. After turning OFF the cylinder and burner control knobs, wait at least 5 minutes for the gas to clear before attempting to light the barbecue. Failure to do so may result in an explosive flame-up, which can cause serious bodily injury or death.

- 3) Turn the cylinder on by turning the cylinder valve counterclockwise.
 - 4) Insert match holder with lit match into the matchlight hole in the front of the cooking box.
- ⚠ **WARNING:** Do not lean over open barbecue. Keep your face and body at least one foot away from the matchlight hole when lighting the barbecue.
- 5) Push BURNER 1 control knob down and turn to START/HI.
 - 6) Check that the burner is lit by looking through the matchlight hole on the front of the cooking box. You should see a flame.
- ⚠ **WARNING:** If the burner does not light, turn the Burner 1 control knob to OFF and wait 5 minutes to let the gas clear before you try again or try to light with a match.
- 7) After BURNER 1 is lit you can turn on BURNER 2 and BURNER 3.
- Note - Always light BURNER 1 first. The other burners ignite from BURNER 1.*

TO EXTINGUISH

Push down and turn each burner control knob clockwise to the OFF position. Turn gas supply OFF at the source.

MAIN BURNER MANUAL LIGHTING

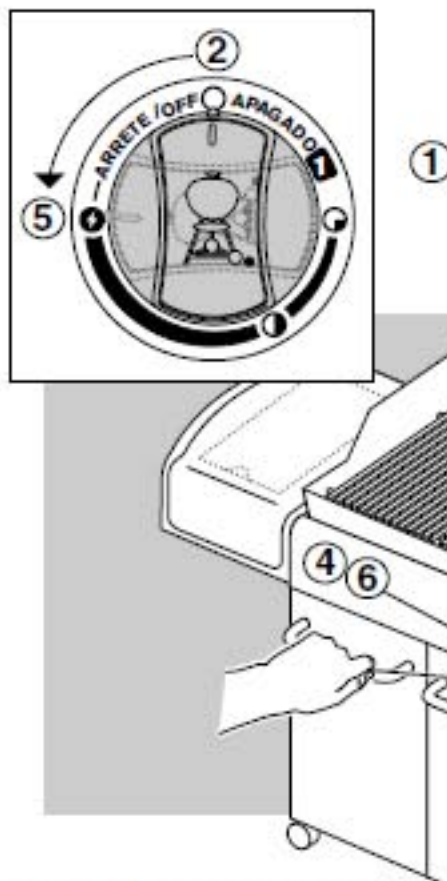

*The grill illustrated may have slight differences than the model purchased.

LIGHTING THE SIDE BURNER

⚠ DANGER

Failure to open the lid while igniting the side burner, or not waiting 5 minutes to allow the gas to clear if the side burner does not light, may result in an explosive flame-up which can cause serious bodily injury or death.

- ⚠ **WARNING:** Check hose before each use of barbecue for nicks, cracking, abrasions or cuts. If the hose is found to be damaged in any way, do not use the barbecue. Replace using only Weber® authorized replacement hose. Contact the Customer Service Representative in your area using the contact information on our web site. Log onto www.weber.com®.

- 1) Open the side burner lid.
- 2) Check that the side burner valve is turned off (Push control knob in and turn clockwise to ensure that it is in the "OFF" position) and all main burner control valves are off (push in and turn clockwise).
- 3) Turn the gas supply valve on.
- 4) Push down and turn the side burner control valve to "HI".
- 5) Press the igniter button several times so it clicks each time.

320

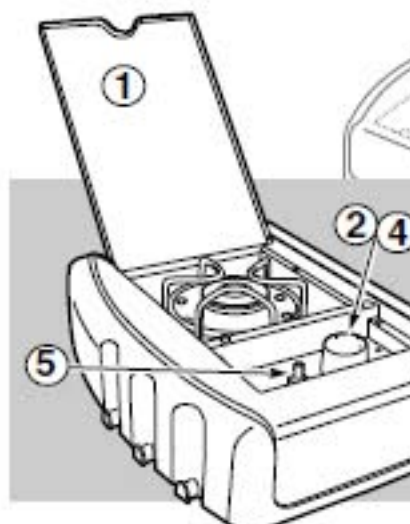

MANUALLY LIGHTING THE SIDE BURNER

⚠ DANGER

Failure to open the lid while igniting the side burner, or not waiting 5 minutes to allow the gas to clear if the side burner does not light, may result in an explosive flare-up that can cause serious bodily injury or death.

- 1) Open the side burner lid.
- 2) Check that the side burner valve is turned off (Push control knob in and turn clockwise to ensure that it is in the "OFF" position) and all main burner control valves are off (push in and turn clockwise).
- 3) Turn the gas supply valve on.
- 4) Put match in a match holder and strike match.
- 5) Hold match holder and lit match by either side of the side burner.
- 6) Push down and turn the side burner control valve to "HI".

⚠ CAUTION: Side burner flame may be difficult to see on a bright sunny day.

⚠ WARNING: If the side burner does not light:

- a) Turn off the side burner control valve, main burners and gas supply at source.
- b) Wait 5 minutes to let the gas clear before you try again.

320

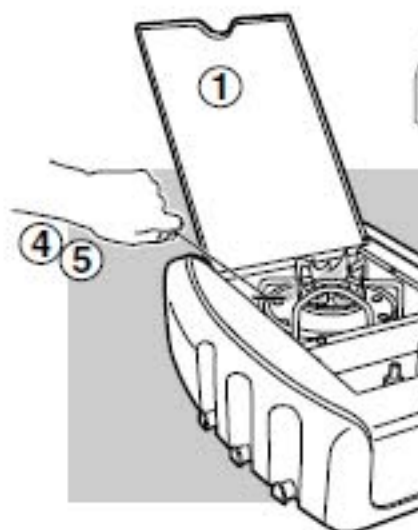

TROUBLESHOOTING

PROBLEM	CHECK	
Burners burn with a yellow or orange flame, in conjunction with the smell of gas.	Inspect Spider/Insect Screens for possible obstructions. (Blockage of holes.)	Clean Spider/Insect Screens
<i>Symptoms:</i> Burners do not light. -or- Burners have a small flickering flame in the "HI" position. -or- Barbecue temperature only reaches 250° to 300° in the "HI" position.	The excess flow safety device, which is part of the barbecue to cylinder connection, may have activated.	To reset the excess flow device, turn the control knobs and the gas supply valve off for 1 minute. Reconnect the gas supply and turn on slowly. Refill LP cylinder.
Burner does not light, or flame is low in "HI" position.	Is LP fuel low or empty?	Refill LP cylinder.
	Is fuel hose bent or kinked?	Straighten fuel hose.
	Does Burner 1 light with a match?	If you can light Burner 1, the Crossover® igniter may be faulty.
Experiencing flare-ups:	Are you preheating barbecue in the prescribed manner?	All burners on for 5 minutes.
	Are the cooking grates and Flavorizer® bars heavily coated with burned-on grease?	Clean thoroughly.
	Is the bottom tray "dirty" and not allowing grease to flow into catch pan?	Clean bottom tray.
⚠ CAUTION: Do not line the bottom tray with aluminum foil.		
Burner flame pattern is erratic. Flame is low when burner is on "HI" Flames do not run the whole length of the burner tube.	Are burners clean?	Clean burners.

SIDE BURNER TROUBLESHOOTING

PROBLEM	CHECK	
Side Burner does not light.	Is gas supply off? The excess flow safety device, which is part of the barbecue to cylinder connection, may have activated.	Turn supply on. To reset the excess flow safety device, turn the valve off. Disconnect the regulator from the START/Hi. Wait at least 1 minute. Turn the regulator to the cylinder. Turn cylinder on.
Flame is low in "HI" position.	Is the fuel hose bent or kinked?	Straighten hose.
Push button ignition does not work.	Does burner light with a match?	If match lights burner, check igniter (see instructions).

If problems cannot be corrected by using these methods, please contact the Customer Service Representative in your area or visit our web site. Log onto www.weber.com.

SIDE BURNER MAINTENANCE

SIDE BURNER MAINTENANCE

⚠ WARNING: All gas controls and supply valves should be in the "OFF" position.

Make sure black wire is connected between the igniter and electrode.
Make sure white wire is connected between the igniter and grounding clip.
Spark should be a white/blue color, not yellow.

- 1) Igniter Wire
- 2) Ground wire
- 3) Burner

- Side Burner Grate
- Side Burner cap
- Side Burner Ring & Head
- Igniter Electrode
- Control Knob
- Igniter

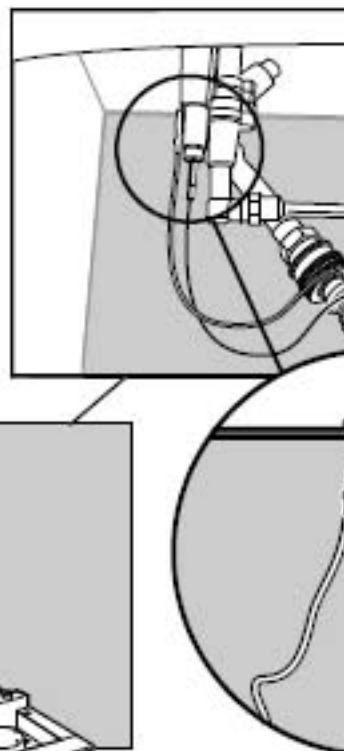
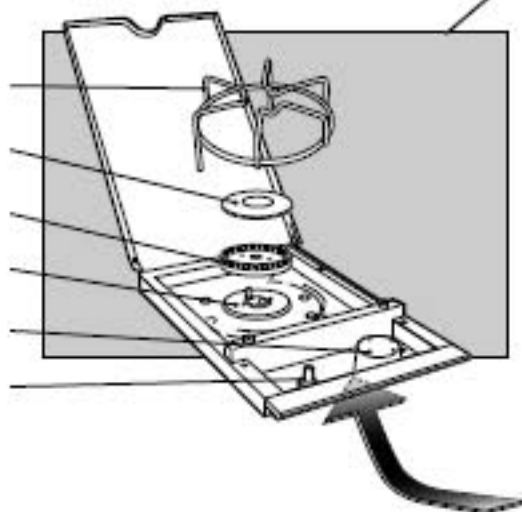

MAINTENANCE

WEBER® SPIDER /INSECT SCREENS

Your Weber® gas barbecue, as well as any outdoor gas appliance, is a target for spiders and other insects. They can nest in the venturi section (1) of the burner tubes. This blocks the normal gas flow, and can cause the gas to flow back out of the combustion air opening. This could result in a fire in and around the combustion air openings, under the control panel, causing serious damage to your barbecue.

The burner tube combustion air opening is fitted with a stainless steel screen (2) to prevent spiders and other insects access to the burner tubes through the combustion air

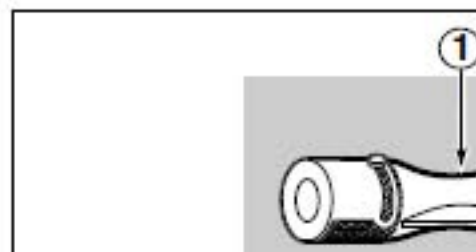

ANNUAL MAINTENANCE

Inspection and cleaning of the Spider/Insect screens

To inspect the Spider/Insect screens, remove the control panel. If there is dust or dirt on the screens, remove the burners for cleaning. Brush the Spider/Insect screens lightly with a soft bristle brush (i.e. an old toothbrush).

⚠ CAUTION: Do not clean the Spider/Insect screens with hard or sharp tools. Do not dislodge the screens or enlarge the screen openings.

Lightly tap the burner to get debris and dirt out of the burner tube. Once the Spider/Insect screens and burners are clean replace the burner. If the Spider/Insect screen becomes damaged or cannot be cleaned, please contact the Customer Service Representative in your area. Log onto www.weber.com.

MAIN BURNER FLAME PATTERN

The Weber® gas barbecue burners have been factory set for the correct air and gas mixture. The correct flame pattern is shown.

- 1) Burner tube
- 2) Tips occasionally flicker yellow
- 3) Light blue
- 4) Dark blue

If the flames do not appear to be uniform throughout the burner tube, follow the burner cleaning procedures.

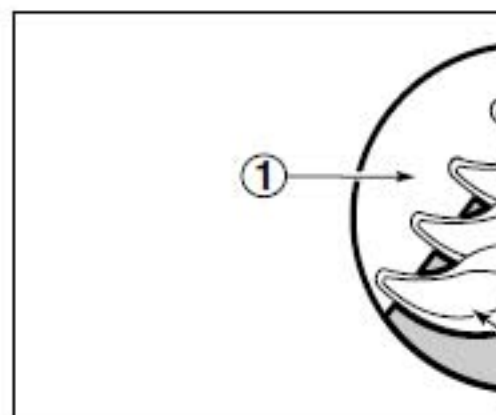

MAIN BURNER CLEANING PROCEDURE

Turn off the gas supply.

Remove the manifold (See "Replace Main Burners").

Look inside each burner with a flashlight.

Clean the inside of the burners with a wire (a straightened-out coat hanger will work).

Check and clean the air shutter opening at the ends of the burners. Check and clean the valve orifices at the base of the valves. Use a Steel bristle brush to clean outside of burners. This is to make sure all the burner ports are fully open.

⚠ CAUTION: Do not enlarge the burner ports when cleaning.

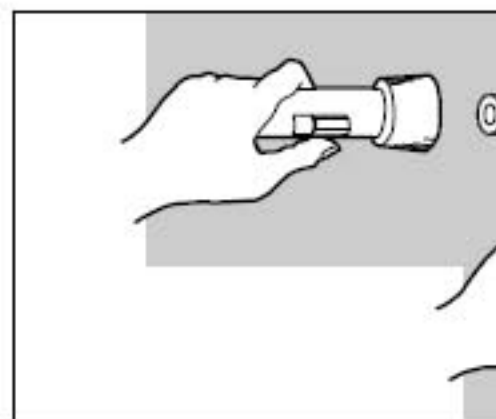

REPLACING MAIN BURNERS

- 1) Your Weber® gas barbecue must be OFF and cool.
- 2) Turn gas OFF at source.
- 3) To remove control panel:
 - (a) Take off the burner control knobs.
 - (b) Remove screw and washer from back of control panel with a Phillips screwdriver.
 - (c) Tilt the back edge of the control panel up. Push in on the front edge to release locking tabs.
 - (d) Disconnect the igniter wires from the ignition module.
 - (e) Carefully pull control panel away from frame.

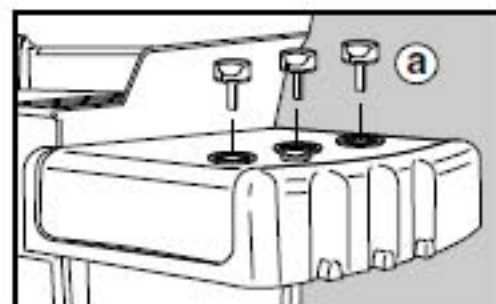

- 4) Loosen the two nuts (a) that hold the manifold to the cooking box. Pull the manifold and valve assembly out of the burners (b) and carefully set it down.

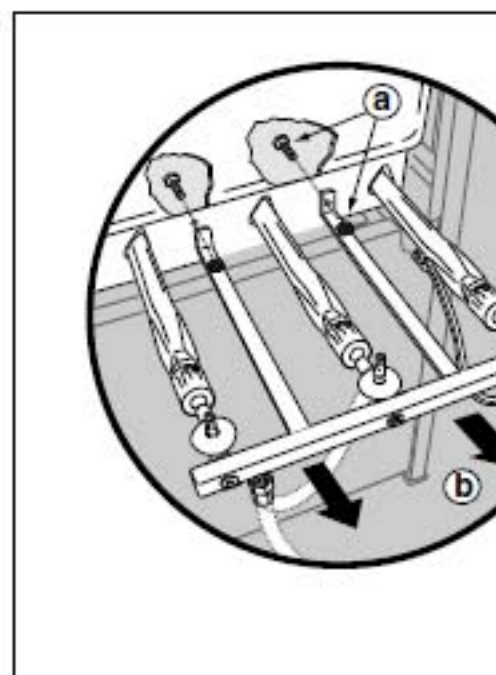

- 5) Slide the burner assembly out from under the guide screw and washer (a) in the corners of the cooking box.
6) Lift and twist the burner assembly slightly, to separate the crossover tube (b) from the burners. Remove the burners from the cooking box.
7) To reinstall the burners, reverse 3) through 7).

⚠ CAUTION: The burner openings (c) must be positioned properly over the valve orifices (d).

Check proper assembly before fastening manifold in place.

⚠ WARNING: After reinstalling the gas lines, they should be leak checked with a soap and water solution before using the barbecue. (See Step: "Check for gas leaks.")

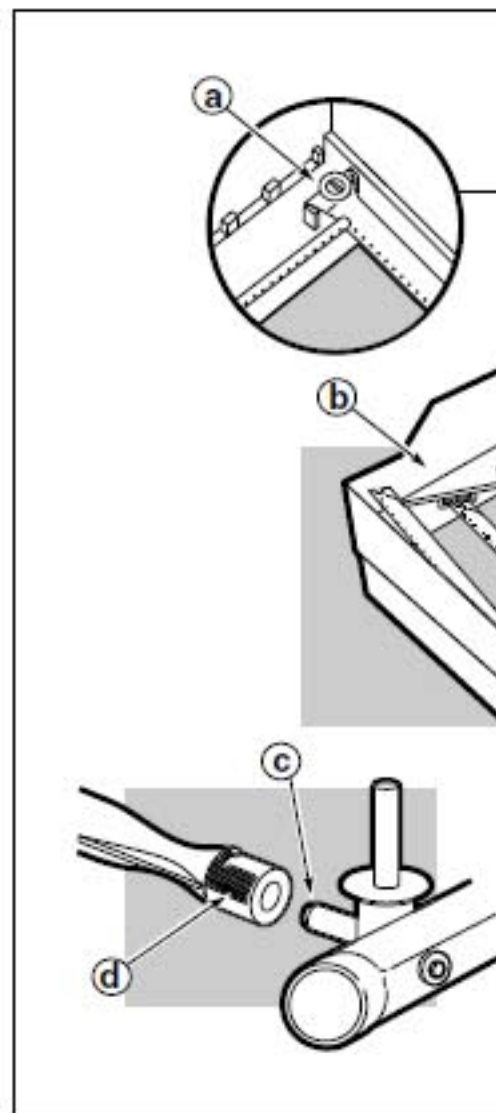

CROSSOVER® IGNITION SYSTEM OPERATIONS

If The Crossover® Ignition System fails to ignite the BURNER 1, light BURNER 1 with a match. If BURNER 1 lights with a match, then check the Electronic Ignition System.

- Check that both of the ignition wires are attached properly.

