

This Owner's Manual is provided and hosted by [Appliance Factory Parts](http://www.appliancefactoryparts.com).



Weber GENESIS SILVER A NG SWE PREMIUM (2005) Owner's Manual

[Shop genuine replacement parts for Weber GENESIS
SILVER A NG SWE PREMIUM \(2005\)](#)



[Find Your Weber Grill Parts - Select From 2037 Models](#)

----- Manual continues below -----

GENESIS® GAS GRILL



Natural Gas Grill Owner's Guide

#55827



**YOU MUST READ THIS OWNERS GUIDE
BEFORE OPERATING YOUR GAS GRILL**

⚠ DANGER

If you smell gas:

1. Shut off gas to the appliance.
 2. Extinguish any open flames.
 3. Open lid
 4. If odor continues, keep away from the appliance and immediately call your gas supplier or your fire department.
- Leaking gas may cause a fire or explosion which can cause serious bodily injury or death, or damage to property.

⚠ WARNING

1. Do not store spare liquid propane cylinder within 10 feet (3m) of this appliance.
2. Do not store or use gasoline or other flammable liquids or vapors within 25 feet (8m) of this appliance.

⚠ WARNING: Follow all leak-check procedures carefully in this manual prior to barbecue operation. Do this even if the barbecue was dealer-assembled.

NOTICE TO INSTALLER: These instructions must be left with the owner and the owner should keep them for future use.

**THIS GAS APPLIANCE IS DESIGNED FOR
OUTDOOR USE ONLY.**

⚠WARNING: Do not try to light this appliance without reading the "Lighting" Instructions section of this manual.



55827 US 10/02/04
NG
US ENGLISH

CONTENTS

DANGERS AND WARNINGS	3
WARRANTY	4
GENERAL INSTRUCTIONS	5
For Installation in Canada.....	5
Storage.....	5
Operating.....	5
Cooking	6
Cleaning.....	6
GAS INSTRUCTIONS	7
Install Gas Supply	7
Check that all burner valves are off	8
Remove control panel and burner control knobs	8
Check the flexible hose to manifold connection.....	9
Check for gas leaks	10
OPERATING INSTRUCTIONS	12
Lighting.....	12
Manual Lighting.....	13
Lighting the Side Burner	14
TROUBLESHOOTING	15
SIDE BURNER TROUBLESHOOTING	16
Side Burner maintenance.....	16
MAINTENANCE	17
Weber® Spider /Insect screens	17
Annual Maintenance	17
Main Burner Flame Pattern	18
Main Burner Cleaning Procedure	18
Replacing Main Burners.....	18
Crossover® Ignition System Operations.....	19

⚠ DANGER

Failure to follow the Dangers, Warnings and Cautions contained in this Owner's Manual may result in serious bodily injury or death, or in a fire or an explosion causing damage to property.

⚠ WARNINGS

- ⚠ Do not store a spare or disconnected liquid propane cylinder under or near this barbecue.
- ⚠ Improper assembly may be dangerous. Please follow the assembly instructions carefully.
- ⚠ After a period of storage, and/or nonuse, the Weber® gas barbecue should be checked for gas leaks and burner obstructions before use. See instructions in this manual for correct procedures.
- ⚠ Do not operate the Weber® gas barbecue if there is a gas leak present.
- ⚠ Do not use a flame to check for gas leaks.
- ⚠ Combustible materials should never be within 24 inches of the top, bottom, back or sides of your Weber® gas barbecue.
- ⚠ Do not put a barbecue cover or anything flammable on, or in the storage area under the barbecue.
- ⚠ Your Weber® gas barbecue should never be used by children. Accessible parts of the barbecue may be very hot. Keep young children away while it is in use.
- ⚠ You should exercise reasonable care when operating your Weber® gas barbecue. It will be hot during cooking or cleaning and should never be left unattended, or moved while in operation.
- ⚠ Should the burners go out while in operation, turn all gas valves off. Open the lid and wait five minutes before attempting to relight, using the lighting instructions.
- ⚠ Do not use charcoal or lava rock in your Weber® gas barbecue.
- ⚠ Never lean over open grill or place hands or fingers on the front edge of the cooking box.
- ⚠ Should a grease fire occur, turn off all burners and leave lid closed until fire is out.
- ⚠ Do not enlarge valve orifices or burner ports when cleaning the valves or burners.
- ⚠ The Weber® gas barbecue should be thoroughly cleaned on a regular basis.
- ⚠ Liquid propane gas is not natural gas. The conversion or attempted use of natural gas in a liquid propane unit or liquid propane gas in a natural gas unit is dangerous and will void your warranty.
- ⚠ Do not attempt to disconnect any gas fitting while your barbecue is in operation.
- ⚠ Use heat-resistant barbecue mitts or gloves when operating barbecue.
- ⚠ Keep any electrical supply cord and the fuel supply hose away from any heated surfaces.
- ⚠ Combustion byproducts produced when using this product contain chemicals known to the state of California to cause cancer, birth defects, or other reproductive harm.
- ⚠ Do not use this barbecue unless all parts are in place. The unit must be properly assembled according to the instructions outlined in the "Assembly Instruction" section of the Owner's Guide.

LIQUID PROPANE GAS UNITS ONLY:

- ⚠ Use the regulator that is supplied with your Weber® gas barbecue.
- ⚠ Do not attempt to disconnect the gas regulator or any gas fitting while your barbecue is in operation.
- ⚠ A dented or rusty liquid propane cylinder may be hazardous and should be checked by your liquid propane supplier. Do not use a liquid propane cylinder with a damaged valve.
- ⚠ Although your liquid propane cylinder may appear to be empty, gas may still be present, and the cylinder should be transported and stored accordingly.
- ⚠ If you see, smell or hear the hiss of escaping gas from the liquid propane cylinder:
 1. Move away from liquid propane cylinder.
 2. Do not attempt to correct the problem yourself.
 3. Call your fire department.

4

WARRANTY

Weber-Stephen Products Co. (Weber) hereby warrants to the ORIGINAL PURCHASER of this Weber® gas grill that it will be free of defects in material and workmanship from the date of purchase as follows:

when assembled and operated in accordance with the printed instructions accompanying it.

Aluminum Castings, lifetime,	1 year paint
Stainless Steel Hood Section,	25 years
Porcelain Hood Section,	25 years
Burners,	10 years
Igniter,	3 years
Porcelain Enameled	
Cooking Grates,	3 years no rust through
Porcelain Enameled Cast Iron	
Cooking Grates,	5 years no rust through
Stainless Steel Cooking Grates,	7 years no rust through
Porcelain Enameled	
Flavorizer® Bars,	1 year no rust through
Stainless Steel	
Flavorizer® Bars,	5 year no rust through
Thermoplastic/Thermoset Parts,	10 years Excluding fading
Rotisserie and all related components,	1 year
All Remaining Parts,	5 years

Weber may require reasonable proof of your date of purchase. THEREFORE, YOU SHOULD RETAIN YOUR SALES SLIP OR INVOICE.

This Limited Warranty shall be limited to the repair or replacement of parts that prove defective under normal use and service and which on examination shall indicate, to Weber's satisfaction, they are defective. Before returning any parts, contact the Customer service representative in your area using the contact information on our website. If Weber confirms the defect and approves the claim, Weber will elect to replace such parts without charge. If you are required to return defective parts, transportation charges must be prepaid. Weber will return parts to the purchaser, freight or postage prepaid. This Limited Warranty does not cover any failures or operating difficulties due to accident, abuse, misuse, alteration, misapplication, vandalism, improper installation or improper maintenance or service, or failure to perform normal and routine maintenance, including but not limited to damage caused by insects within the burner tubes, as set out in this owner's manual. Deterioration or damage due to severe weather conditions such as hail, hurricanes, earthquakes or tornadoes, discoloration due to exposure to chemicals either directly or in the atmosphere, is not covered by this Limited Warranty.

There are no other express warrants except as set forth herein and any applicable implied warranties of merchantability and fitness are limited in duration to the period of coverage of this express written Limited Warranty. Some regions do not allow limitation on how long an implied warranty lasts, so this limitation may not apply to you.

Weber is not liable for any special, indirect or consequential damages. Some regions do not allow the exclusion or limitation of incidental or consequential damages, so this limitation or exclusion may not apply to you.

Weber does not authorize any person or company to assume for it any other obligation or liability in connection with the sale, installation, use, removal, return, or replacement of its equipment; and no such representations are binding on Weber.

This Warranty applies only to products sold at retail.

WEBER-STEPHEN PRODUCTS CO.

Customer Service Center
1890 Roselle Road, Suite 308
Schaumburg, IL 60195
USA

For replacement parts call:

1-800-446-1071
www.weber.com®

Your Weber® gas barbecue is a portable outdoor cooking appliance. With the Weber® gas barbecue you can grill, barbecue, roast and bake with results that are difficult to duplicate with indoor kitchen appliances. The closed lid and Flavorizer® bars produce that “outdoor” flavor in the food.

The Weber® gas barbecue is portable so you can easily change its location in your yard or on your patio. Portability means you can take your Weber® gas barbecue with you if you move.

The natural gas supply is easy to use and gives you more cooking control than charcoal fuel.

- These instructions will give you the minimum requirements for assembling your Weber® gas barbecue. Please read the instructions carefully before using your Weber® gas barbecue. Improper assembly can be dangerous.
- Not for use by children.
- If there are local codes that apply to portable gas grills, you will have to conform to them. If there are no local codes, you must conform to the latest edition of the National Fuel Gas Code: ANSI Z 223.1/NFPA 54, or CAN/CGA-B149.1, Natural Gas and Propane Installation Code.
- This Weber® gas barbecue is designed for natural (piped in city) gas only. Do not use liquid propane (LP) bottled gas. The valves, orifices and hose are for natural gas only.
- Do not use with charcoal fuel.
- Check that the area under the control panel and the bottom tray are free from debris that might obstruct the flow of combustion or ventilation air.

FOR INSTALLATION IN CANADA

These instructions, while generally acceptable, do not necessarily comply with the Canadian Installation codes, particularly with piping above and below ground. In Canada the installation of this appliance must comply with local codes and/or Standards CAN/CGA-B149.1 (Installation Code for Natural Gas Burning Appliances and Equipment).

STORAGE

- The gas must be turned OFF at the natural gas supply when the Weber® gas barbecue is not in use.
- When the Weber® gas barbecue is stored indoors, the gas supply must be disconnected.
- The Weber® gas barbecue should be checked for gas leaks and any obstructions in the burner tubes before using. (See Sections: “General Maintenance and Annual Maintenance.”)
- Check that the areas under the control panel and the slide out bottom tray are free from debris that might obstruct the flow of combustion or ventilation air.
- The Spider /Insect Screens should also be checked for any obstructions. (See Section: “Annual Maintenance.”)

OPERATING

- ⚠ **WARNING: Only use this barbecue outdoors in a well-ventilated area. Do not use in a garage, building, breezeway or any other enclosed area.**
- ⚠ **WARNING: Your Weber® gas barbecue shall not be used under overhead combustible construction.**
- ⚠ **WARNING: Your Weber® gas barbecue is not intended to be installed in or on recreational vehicles and/or boats.**
- ⚠ **WARNING: Do not use the barbecue within 24 inches of combustible materials, top, bottom, back or sides of the grill.**
- ⚠ **WARNING: The entire cooking box gets hot when in use. Do not leave unattended.**
- ⚠ **WARNING: Keep any electrical supply cord and the fuel supply hose away from any heated surface.**
- ⚠ **WARNING: Keep the cooking area clear of flammable vapors and liquids, such as gasoline, alcohol, etc., and combustible materials.**
- ⚠ **WARNING: The LP cylinder used with your barbecue must be with an OPD (Overfilling Prevention Device) and a QCC1 or Type 1 (CGA810) cylinder connection. The cylinder connection must be compatible with the barbecue connection.**

Gas Supply Testing

- Disconnect your Weber® gas barbecue when the gas supply is being tested at high pressures. This appliance and its individual shutoff valve must be disconnected from the gas supply piping system during any pressure testing of that system at test pressures in excess of 1/2 psig (3.5 kPa).
- Turn OFF your Weber® gas barbecue when the gas supply is being tested at low pressures. This appliance must be isolated from the gas supply piping system by closing its individual manual shutoff valve during any pressure testing of the gas supply piping system at the pressure equal to or less than 1/2 psig (3.5 kPa).

6

GENERAL INSTRUCTIONS

COOKING

⚠ WARNING: Do not move the Weber® gas barbecue when operating or while barbecue is hot.

You can adjust the FRONT and BACK burners as desired. The control settings: High (H), Medium (M), Low (L), or Off (O) are described in your Weber® cookbook. The cookbook uses these notations to describe the settings of the FRONT and BACK burners. For example, to sear steaks, you would set all burners at H (high). Then to complete cooking, you would set FRONT and BACK at M (medium). Refer to your Weber® cookbook for detailed cooking instructions.

Note: The temperature inside your cooking box for the first few uses, while surfaces are still very reflective, may be hotter than those shown in your cookbook. Cooking conditions. Such as wind and weather, may require the adjustment of the burner controls to obtain the correct cooking temperatures.

If burners go out during cooking, open lid, turn off all burners and wait five minutes before relighting.

Preheating - Your Weber® gas barbecue is an energy-efficient appliance. It operates at an economical low BTU rate. To preheat: after lighting, close lid and turn all burners to high (HH). Preheating to between 500° and 550° F (260° and 290° C) will take 10 to 15 minutes depending on conditions such as air temperature and wind.

Drippings and grease - The Flavorizer® bars are designed to “smoke” the correct amount of drippings for flavorful cooking. Excess drippings and grease will accumulate in the catch pan under the slide out bottom tray. Disposable foil drip pans are available that fit the catch pan.

⚠ WARNING: Check the bottom tray for grease build-up before each use. Remove excess grease to avoid a grease fire in the slide out bottom tray.

CLEANING

⚠ WARNING: Turn your Weber® gas barbecue OFF and wait for it to cool before cleaning.

⚠ CAUTION: Do not clean your Flavorizer® bars or cooking grates in a self-cleaning oven.

For availability of replacement cooking grates and Flavorizer® bars Contact the Customer Service Representative in your area using the contact information on our web site. Log onto www.weber.com.

Outside surfaces - Use a warm soapy water solution to clean, then rinse with water.

⚠ CAUTION: Do not use oven cleaner, abrasive cleansers (kitchen cleansers) cleaners that contain citrus products, or abrasive cleaning pads on barbecue or cart surfaces.

Slide out Bottom tray - Remove excess grease, then wash with warm soapy water, then rinse

Flavorizer® bars and Cooking grates - Clean with a suitable brass bristle brush. As needed, remove from grill and wash with warm soapy water, then rinse with water.

Catch pan - Disposable foil trays are available, or you can line the catch pan with aluminum foil. To clean the catch pan, wash with warm soapy water, then rinse.

Thermometer - Wipe with warm soapy water; clean with plastic scrub ball. Do not put in dishwasher or submerge in water.

Inside cooking module - Brush any debris off of burner tubes. **DO NOT ENLARGE BURNER PORTS (OPENINGS)**. Wash inside of cooking box with warm soapy water and a water rinse.

Inside Lid - While lid is warm, wipe inside with paper towel to prevent grease build-up. Flaking built-up grease resembles paint flakes.

Stainless steel surfaces - Wash with a soft cloth and a soap and water solution. Be careful to scrub with the grain direction of the stainless steel.

Thermoset surfaces - Wash with a soft cloth and a soap and water solution.

Do not use cleaners that contain acid, mineral spirits or xylene. Rinse well after cleaning.

Thermoset work surfaces are not to be used as cutting boards.

INSTALL GAS SUPPLY

General Specifications for Piping

Note - Contact your local municipality for building codes regulating outdoor gas barbecue installations. In absence of Local Codes, you must confirm to the latest edition of ANSI Z223.1. WE RECOMMEND THAT THIS INSTALLATION BE DONE BY A PROFESSIONAL.

Some of the following are general requirements taken from ANISI Z223.1 latest edition for complete specifications.

- This barbecue is designed to operate at 7 inches of water column pressure (.2526 psi).
A manual shut-off valve must be installed outdoors, immediately ahead of the quick disconnect.
- An additional manual shut-off valve indoors should be installed in the branch fuel line in an accessible location near the supply line
- The quick disconnect connects to a 3/8 inch NPT thread from the gas source. The quick disconnect fitting is a hand-operated device that automatically shuts OFF the flow of gas from the source when the barbecue is disconnected
- The quick disconnect fitting can be installed horizontally, or pointing downward. Installing the fitting with the open end pointing upward can result in collecting water and debris.
- The dust covers (supplied plastic plugs) help keep the open ends of the quick disconnect fitting clean while disconnected.
- Pipe compound should be used which is resistant to the action of natural gas when connections are made.
- The outdoor connector must be firmly attached to rigid, permanent construction.

⚠ WARNING: Do not route the 10 foot hose under a deck. The hose must be visible.

Gas Line Piping

- If the length of the line required does not exceed 50 feet, use a 5/8" O.D. tube. One size larger should be used for lengths greater than 50 feet.
- Gas piping may be copper tubing, type K or L; polyethylene plastic tube, with a minimum wall thickness of .062 inch; or standard weight (schedule 40) steel or wrought iron pipe.
- Copper tubing must be tin-lined if the gas contains more than 0.3 grams of hydrogen sulfide per 100 cubic feet of gas.
- Plastic tubing is suitable only for outdoor, underground use.
- Gas piping in contact with earth, or any other material which may corrode the piping, must be protected against corrosion in an approved manner.
- Underground piping must have a minimum of 18" cover

Test Connections

All connections and joints must be thoroughly tested for leaks in accordance with local codes and all listed procedures in the latest edition of ANSI Z223.1

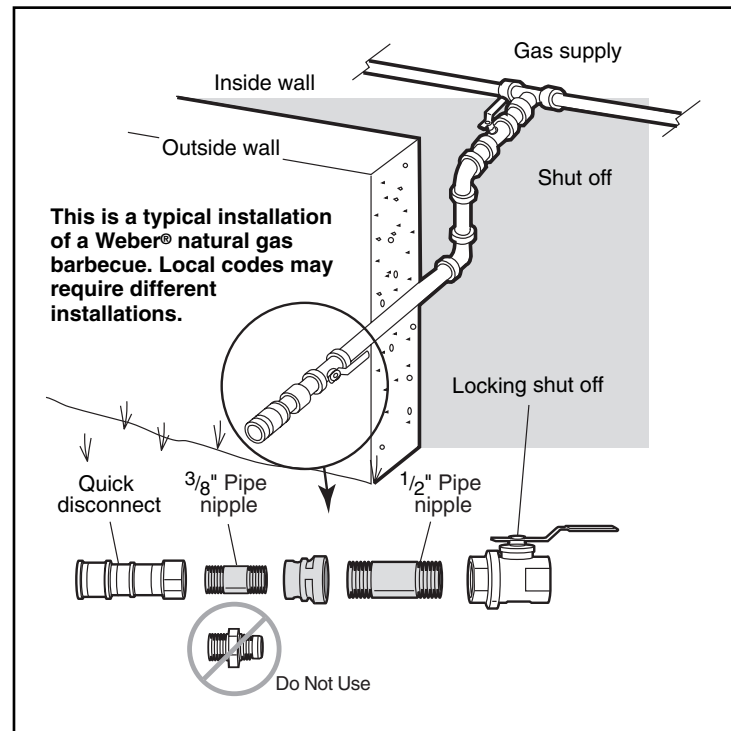

⚠ DANGER

Do not use an open flame to check for gas leaks. Be sure there are no sparks or open flames in the area while you check for gas leaks. This will result in a fire or explosion which can cause serious bodily injury or death and damage to property.

8

GAS INSTRUCTIONS

CHECK THAT ALL BURNER VALVES ARE OFF

Valves are shipped in the OFF position, but you should check to be sure that they are turned OFF. Check by pushing down and turning clockwise. If they do not turn, they are off. Proceed to the next step. If they do turn continue turning them clockwise until they stop, then they are off. Proceed to the next step.

REMOVE CONTROL PANEL AND BURNER CONTROL KNOBS

You will need: *Phillips screwdriver.*

- 1) Remove control knobs.

SILVER, GOLD AND PLATINUM C MODELS

- 2a) Unhook side burner from Cookbox Frame.

- 2) Remove screws with a Phillips screwdriver
- 3) Pull up igniter button until it sticks in the up position and remove control panel from grill.
- 4) Replace control panel when Leak Check is completed.

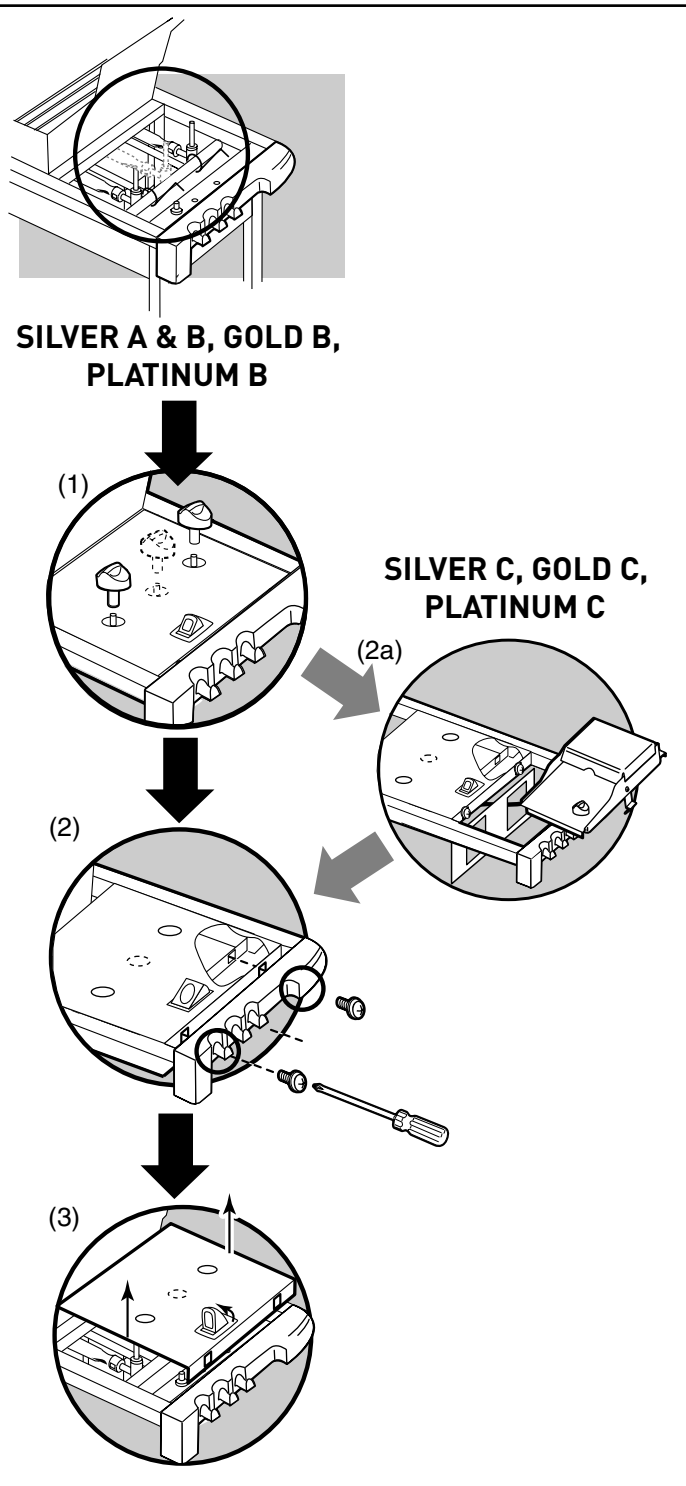

CHECK THE FLEXIBLE HOSE TO MANIFOLD CONNECTION

The Natural gas hose has been attached during the manufacturing process. We do recommend that the hose to gas manifold connection be leak tested, following guidelines in this Owners Guide, prior to barbecue operation.

Check:

1) Hose to manifold connection.

⚠ WARNING: If there is a leak at connection(1), retighten the fitting with a wrench and recheck for leaks with soap and water solution. If a leak persists after retightening the fitting, turn OFF the gas. DO NOT OPERATE THE GRILL. Contact the Customer Service Representative in your area using the contact information on our web site. Log onto www.weber.com.

SILVER A & B, GOLD B, PLATINUM B

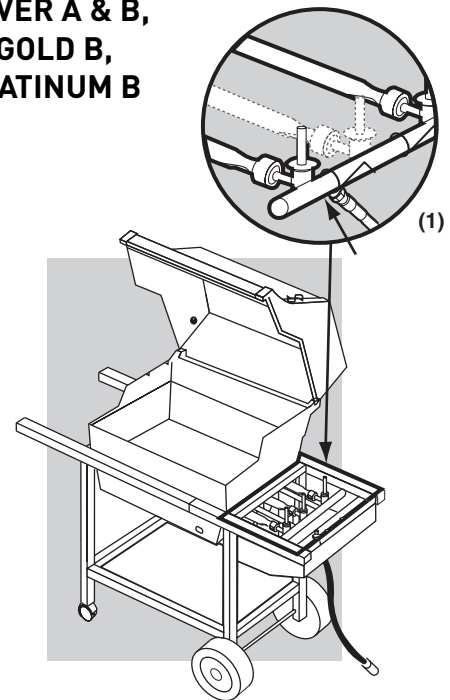

**The grill illustrated may have slight differences than the model purchased.*

SILVER C, GOLD C, PLATINUM C

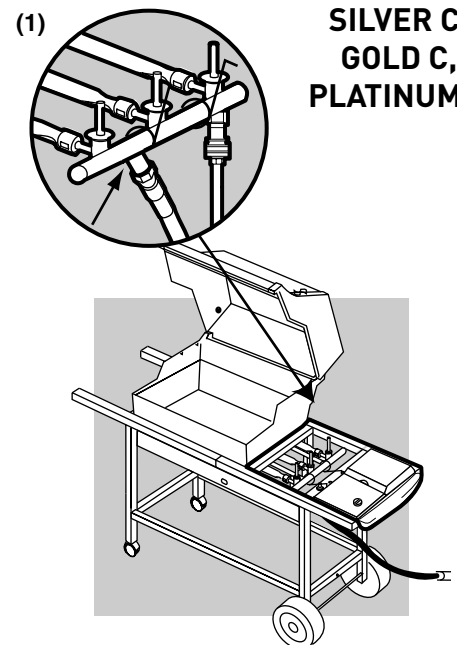

**The grill illustrated may have slight differences than the model purchased.*

10

GAS INSTRUCTIONS

CHECK FOR GAS LEAKS

⚠ DANGER

Do not use an open flame to check for gas leaks. Be sure there are no sparks or open flames in the area while you check for leaks. Sparks or open flames will result in a fire or explosion which can cause serious bodily injury or death and damage to property.

⚠ WARNING: You should check for gas leaks every time you disconnect and reconnect a gas fitting.

Note - All factory-made connections have been thoroughly checked for gas leaks. The burners have been flame-tested. As a safety precaution however, you should recheck all fittings for leaks before using your Weber® gas barbecue. Shipping and handling may loosen or damage a gas fitting.

⚠ WARNING: Perform these leak checks even if your barbecue was dealer or store assembled.

You will need: a soap and water solution, and a rag or brush to apply it.
Make sure side burner is OFF. Remove valve control knob and screws.
Remove porcelain top.

To perform leak checks: Slide back the collar of the quick disconnect. Push male fitting of the hose into the quick disconnect, and maintain pressure(1). Slide the collar closed(2). If it does not engage or lock, repeat procedure. Gas will not flow unless the quick disconnect is properly engaged.

Turn on gas supply.

Check for leaks by wetting the connections with the soap and water solution and watching for bubbles. If bubbles form or if a bubble grows, there is a leak.

Note - Since some leak test solutions, including soap and water, may be slightly corrosive, all connections should be rinsed with water after checking for leaks.

⚠ WARNING: Do not ignite burners when leak checking.

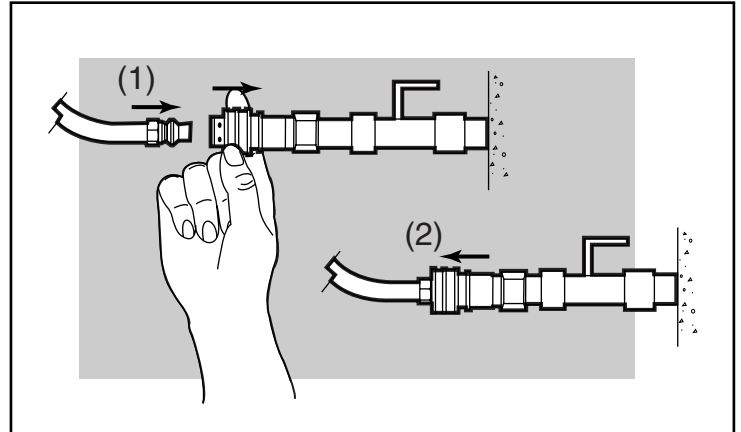

Check:

1) Hose to manifold connection.

⚠ WARNING: If there is a leak at connection(1), retighten the fitting with a wrench and recheck for leaks with soap and water solution. If a leak persists after retightening the fitting, turn OFF the gas. DO NOT OPERATE THE GRILL. Contact the Customer Service Representative in your area using the contact information on our web site. Log onto www.weber.com.

2) Valves to manifold connection

3) Hose to quick disconnect connection

⚠ WARNING: If there is a leak at connections(1) or(2) turn OFF the gas. DO NOT OPERATE THE GRILL. Contact the Customer Service Representative in your area using the contact information on our web site. Log onto www.weber.com.

When leak checks are complete, turn gas supply OFF at the source and rinse connections with water.

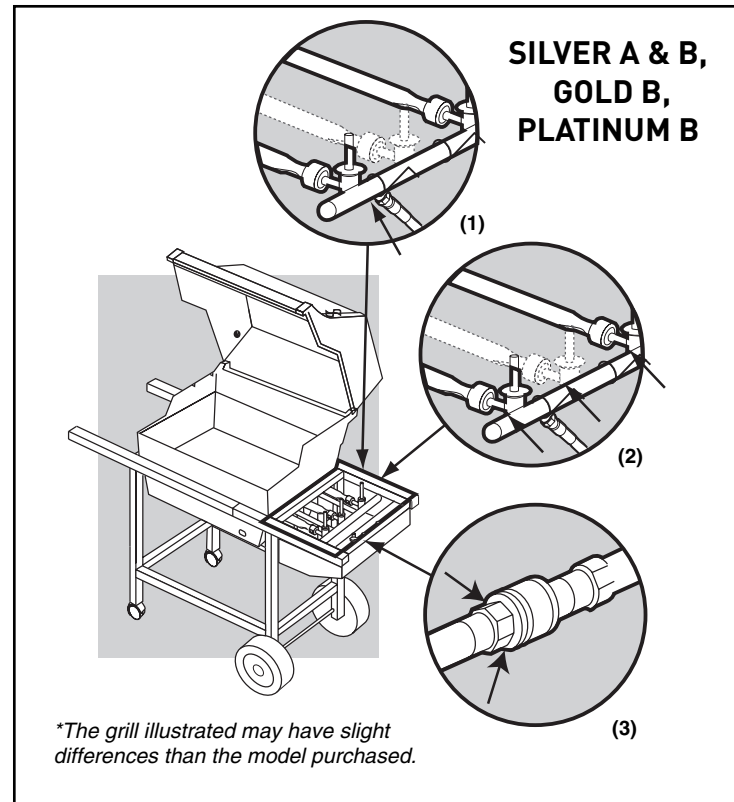

Check:

1) Hose to manifold connection

2) Manifold to side burner hose connection

⚠ WARNING: If there is a leak at connection(1), retighten the fitting with a wrench and recheck for leaks with soap and water solution. If a leak persists after retightening the fitting, turn OFF the gas. DO NOT OPERATE THE GRILL. Contact the Customer Service Representative in your area using the contact information on our web site. Log onto www.weber.com.

3) Side burner hose to side burner connection

4) Valves to manifold connections

5) Hose to quick disconnect connection

⚠ WARNING: If there is a leak at connections(2),(3),(4) or(5), turn OFF the gas. DO NOT OPERATE THE GRILL. Contact the Customer Service Representative in your area using the contact information on our web site. Log onto www.weber.com.

When leak checks are complete, turn gas supply OFF at the source and rinse connections with water.

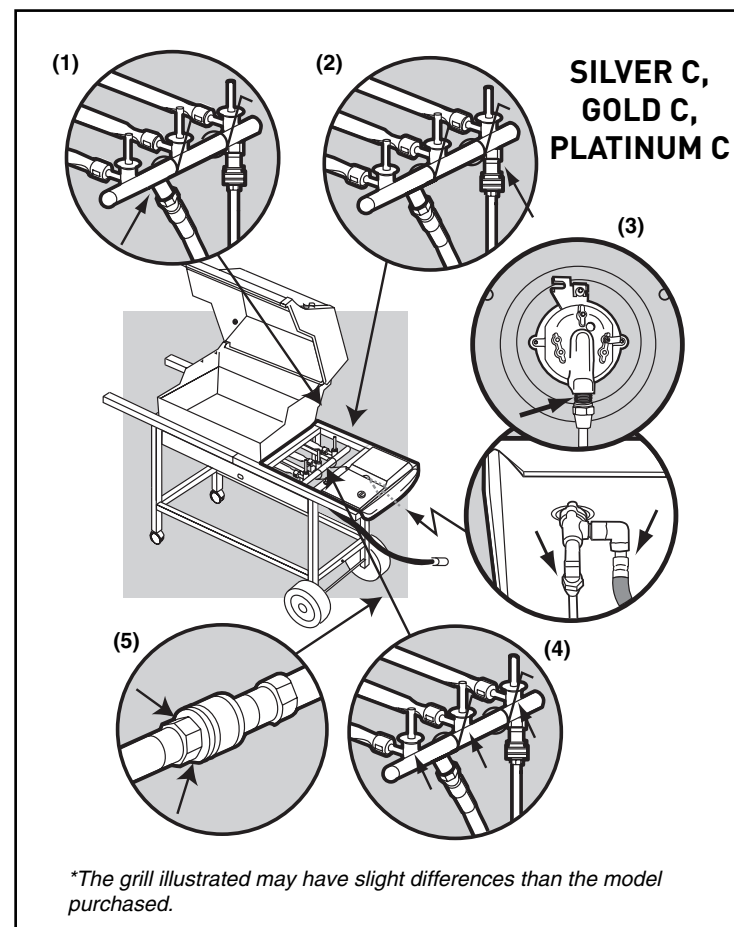

12

OPERATING INSTRUCTIONS

LIGHTING

Summary lighting instructions are on the control panel.

⚠ DANGER

Failure to open the lid while igniting the barbecue's burners, or not waiting 5 minutes to allow the gas to clear if the barbecue does not light, may result in an explosive flame-up which can cause serious bodily injury or death.

Crossover® Ignition System

Note - The Crossover® ignition system ignites the Front burner with a spark from the igniter electrode inside the Gas Catcher™ ignition chamber. You generate the energy for the spark by pushing the Crossover® ignition button until it clicks.

⚠ **WARNING:** Check hose before each use of barbecue for nicks, cracking, abrasions or cuts. If the hose is found to be damaged in any way, do not use the barbecue. Replace using only Weber® authorized replacement hose. Contact the Customer Service Representative in your area using the contact information on our web site. Log onto www.weber.com.

- 1) Open the lid.
- 2) Make sure all burner control knobs are turned OFF. (Push each burner control knob down and turn clockwise to ensure that they are in the off position.)
- 3) Turn the gas supply valve on.

⚠ **WARNING:** Do not lean over the open barbecue. Keep your face and body at least one foot away from the matchlight hole when lighting the barbecue.

- 4) Push Front burner control knob down and turn to START/Hi.
- 5) Push the Crossover® Ignition Button several times, so it clicks each time.
- 6) Check that the burner is lit by looking through the matchlight hole on the front of the cooking box. You should see flame.

⚠ **WARNING:** If the burner does not light, turn the Front burner control knob to OFF and wait 5 minutes to let the gas clear before you try again, or try to light with a match.

- 7) After the FRONT burner is lit you can turn on the other burner or burners.

Note - Always light the FRONT burner first. The other burner or burners ignite from the FRONT burner.

MAIN BURNER LIGHTING

SILVER A & B

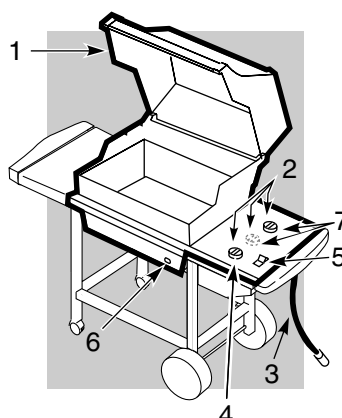

SILVER C GOLD B & C PLATINUM B & C

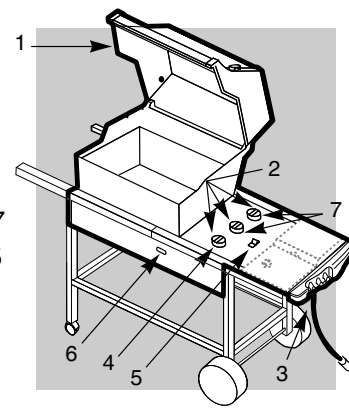

*The grill illustrated may have slight differences than the model purchased.

TO EXTINGUISH

Push down and turn each burner control knob clockwise to the OFF position. Turn gas supply OFF at the source.

MANUAL LIGHTING

⚠ DANGER

Failure to open lid while igniting the barbecue's burners, or not waiting 5 minutes to allow the gas to clear if the barbecue does not light, may result in an explosive flame-up which can cause serious bodily injury or death.

- 1) Open the lid.
- 2) Make sure all burner control knobs are turned OFF. (Push each burner control knob down and turn clockwise to ensure they are in the off position.)
- 3) Turn the gas supply valve on.
- 4) Strike a match and put the flame into the matchlight hole in the front of the cooking box.

⚠ WARNING: Do not lean over the open barbecue. Keep your face and body at least one foot away from the matchlight hole when lighting the barbecue.

- 5) Push Front burner control knob down and turn to START/Hi.
- 6) Check that the burner is lit by looking through the matchlight hole on the front of the cooking box. You should see a flame.

⚠ WARNING: If the burner does not light, turn the Front burner control knob to OFF and wait 5 minutes to let the gas clear before you try again or try to light with a match.

- 7) After the FRONT burner is lit you can turn on the other burner or burners.

Note - Always light the FRONT burner first. The other burner or burners ignite from the FRONT burner.

MAIN BURNER LIGHTING

SILVER A & B

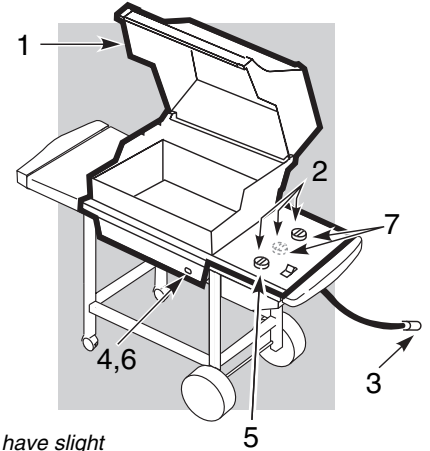

**The grill illustrated may have slight differences than the model purchased.*

MAIN BURNER LIGHTING

SILVER C GOLD B & C PLATINUM B & C

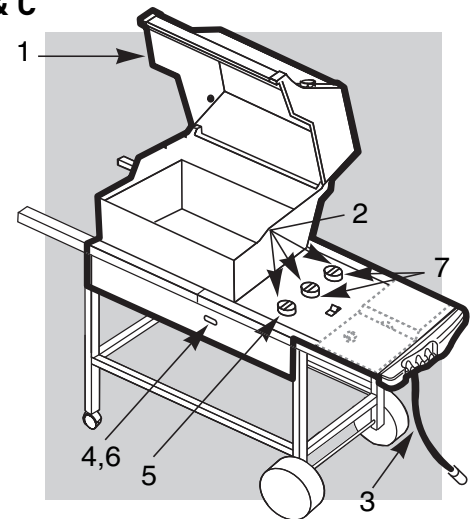

**The grill illustrated may have slight differences than the model purchased.*

TO EXTINGUISH

Push down and turn each burner control knob clockwise to the OFF position. Turn gas supply OFF at the source.

14

OPERATING INSTRUCTIONS

LIGHTING THE SIDE BURNER

⚠ DANGER

Failure to open the lid while igniting the side burner, or not waiting 5 minutes to allow the gas to clear if the side burner does not light, may result in an explosive flame-up which can cause serious bodily injury or death.

Lighting only the side burner.

- 1) Open the side burner lid.
- 2) Check that the side burner valve is turned OFF. (Push each knob down and turn clockwise to ensure they are in the off position.), and all main burner control valves are OFF (push down and turn clockwise).
- 3) Turn the LP tank valve on (turn counter-clockwise).
- 4) Push down and turn the side burner control valve to HI.
- 5) Press the igniter button several times so it clicks each time.

⚠ **CAUTION: Side burner flame may be difficult to see on a bright sunny day.**

⚠ **WARNING: If the side burner does not light:**

- 1) Turn OFF the side burner control valve.
- 2) Wait 5 minutes to let the gas clear before you try again or try to light with a match.

Lighting the side burner if the main burners are lit.

- 1) Open the side burner lid.
- 2) Push down and turn the side burner control to HI.
- 3) Press the igniter button several times so it clicks each time.

⚠ **CAUTION: Side burner flame may be difficult to see on a bright sunny day.**

⚠ **WARNING: If the side burner does not light:**

- 1) Turn OFF the side burner control valve.
- 2) Wait 5 minutes to let the gas clear before you try again or try to light with a match.

LIGHTING WITH IGNITER

FOR SIDE BURNER MODELS

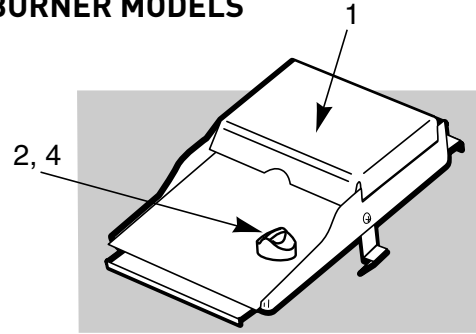

**The grill illustrated may have slight differences than the model purchased.*

MANUAL LIGHTING

FOR SIDE BURNER MODELS

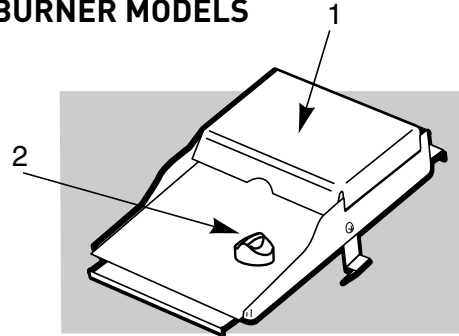

**The grill illustrated may have slight differences than the model purchased.*

PROBLEM	CHECK	CURE
Burners burn with a yellow or orange flame, in conjunction with the smell of gas.	Inspect Spider / Insect Screens for possible obstructions. (Blockage of holes.)	Clean Spider / Insect Screens. (See Section "Annual Maintenance")
Burner does not light, or flame is low in HIGH position.	Is LP fuel low or empty?	Refill LP cylinder.
	Is fuel hose bent or kinked?	Straighten fuel hose.
	Does the Left burner light with a match?	If you can light the Left burner with a match, then check the Crossover [®] ignition system.
Experiencing flare-ups: ⚠ CAUTION: Do not line the bottom tray with aluminum foil.	Are you preheating barbecue in the prescribed manner?	All burners on high for 10 to 15 minutes for preheating.
	Are the cooking grates and Flavorizer [®] bars heavily coated with burned-on grease?	Clean thoroughly. (See Section "Cleaning")
	Is the bottom tray "dirty" and not allowing grease to flow into catch pan?	Clean bottom tray
Burner flame pattern is erratic. Flame is low when burner is on HIGH. Flames do not run the whole length of the burner tube.	Are burners clean?	Clean burners. (See Section "Maintenance".)
Inside of lid appears to be "peeling." (Resembles paint peeling.)	The lid is stainless steel, not paint. It cannot "peel". What you are seeing is baked on grease that has turned to carbon and is flaking off. THIS IS NOT A DEFECT.	Clean thoroughly. (See Section "Cleaning".)
If problems cannot be corrected by using these methods, please contact the Customer Service Representative in your area using the contact information on our web site. Log onto www.weber.com[®].		

16

SIDE BURNER TROUBLESHOOTING

PROBLEM	CHECK	CURE
Side Burner does not light.	Is gas supply off?	Turn supply on.
Flame is low in HIGH position	Is the fuel hose bent or kinked?	Straighten hose.
Push button ignition does not work.	Does burner light with a match?	If match lights burner, check igniter (see below).

If problems cannot be corrected by using these methods, please contact the Customer Service Representative in your area using the contact information on our web site. Log onto www.weber.com®.

SIDE BURNER MAINTENANCE

⚠WARNING: All gas controls and supply valves should be in the OFF position.

Make sure black wire is connected between the igniter and electrode

(1). Make sure white wire is connected between the igniter and grounding clip

(2). Spark should be a white/blue color, not yellow.

- 1) Igniter Wire
- 2) Ground wire
- 3) Burner

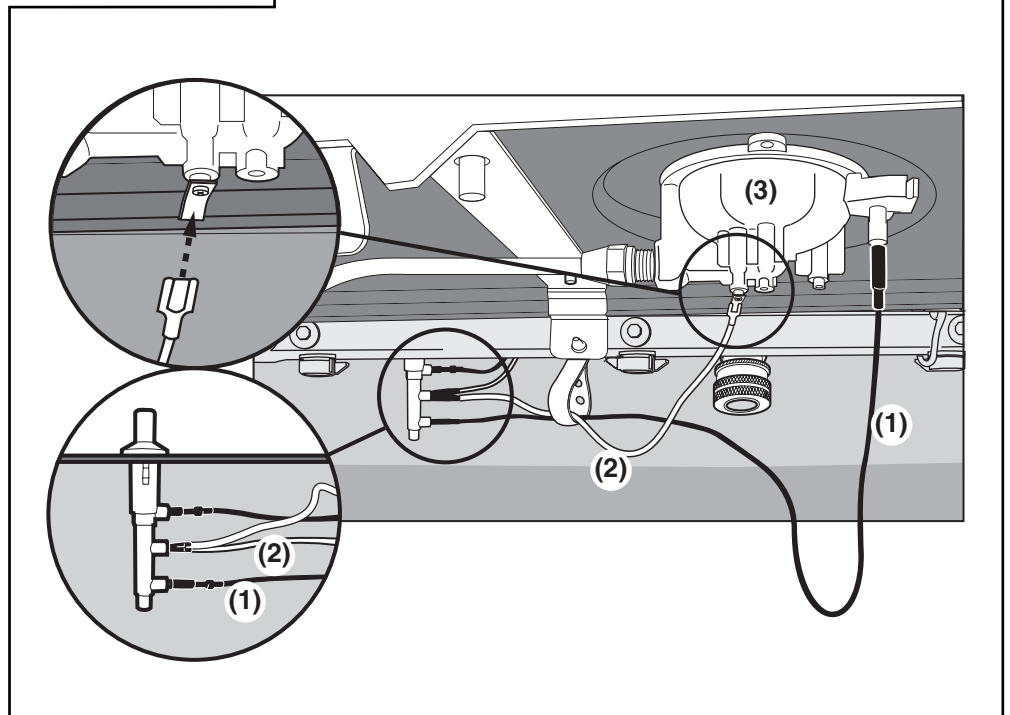
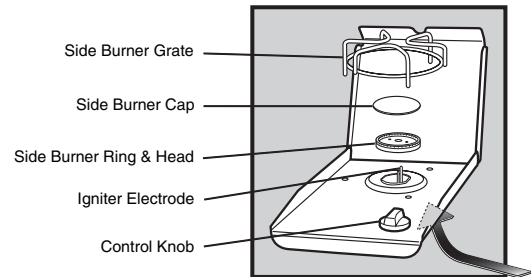

WEBER® SPIDER /INSECT SCREENS

Your Weber® gas barbecue, as well as any outdoor gas appliance, is a target for spiders and other insects. They can nest in the venturi section(1) of the burner tubes. This blocks the normal gas flow, and can cause the gas to flow back out of the air shutter. This could result in a fire in and around the air shutters, under the control panel, causing serious damage to your barbecue. The burner tube air shutter is fitted with a stainless steel screen(1) to prevent spiders and other insects access to the burner tubes through the air shutter openings.

We recommend that you inspect the Spider/Insect screens at least once a year. (See Section “Annual Maintenance”.) Also inspect and clean the the Spider/Insect screens if any of the following symptoms should ever occur:

- 1) The smell of gas in conjunction with the burner flames appearing yellow and lazy.
- 2) Barbecue does not reach temperature.
- 3) Barbecue heats unevenly.
- 4) One or more of the burners do not ignite.

⚠DANGER

Failure to correct the above mentioned symptoms may result in a fire, which can cause serious bodily injury or death, and cause damage to property.

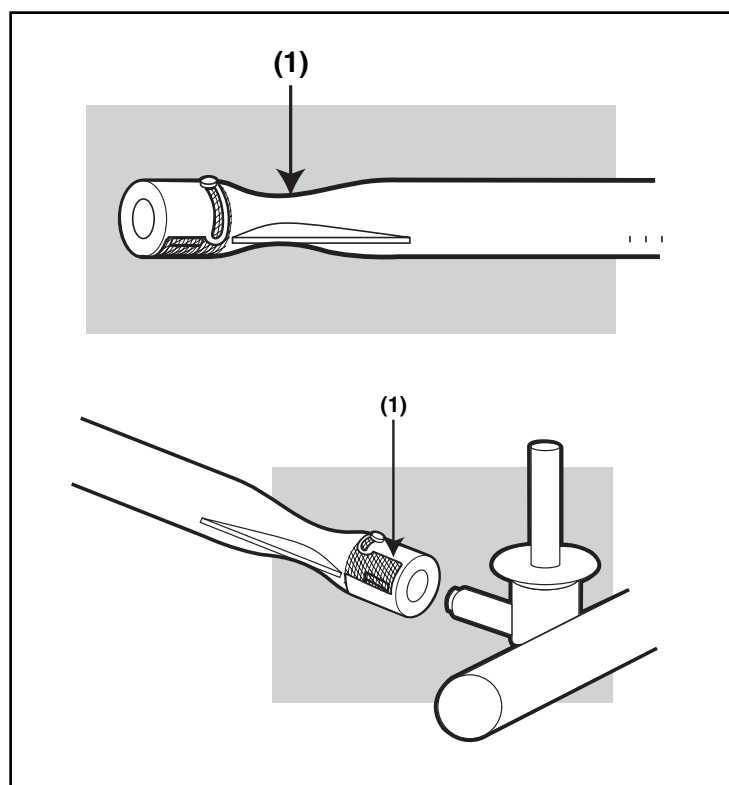

ANNUAL MAINTENANCE

Inspection and cleaning of the Spider/Insect screens

To inspect the spider/insect screens, remove the control panel. If there is dust or dirt on the screens, remove the burners for cleaning the screens.

Brush the spider/insect screens, lightly, with a soft bristle brush (i.e. an old toothbrush).

⚠ CAUTION: Do not clean the spider/insect screens with hard or sharp tools. Do not dislodge the spider/insect screens or enlarge the screen openings.

Lightly tap the burner to get debris and dirt out of the burner tube. Once the spider/insect screens and burners are clean replace the burners.

If the spider/insect screen becomes damaged or cannot be cleaned, call Weber-Stephen Products Customer Service for replacement parts.

MAIN BURNER FLAME PATTERN

The Weber® gas barbecue burners have been factory set for the correct air and gas mixture. The correct flame pattern is shown.

- 1) Burner tube
- 2) Tips occasionally flicker yellow
- 3) Light blue
- 4) Dark blue

If the flames do not appear to be uniform throughout the burner tube, follow the burner cleaning procedures.

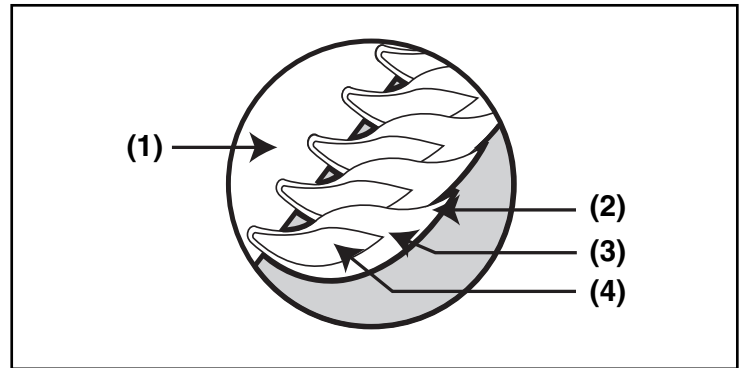

MAIN BURNER CLEANING PROCEDURE

Turn off the gas supply.

Remove the manifold.

Look inside each burner with a flashlight.

Clean the inside of the burners with a wire (a straightened-out coat hanger will work). Check and clean the air shutter opening at the ends of the burners. Check and clean the valve orifices at the base of the valves. Use a Steel bristle brush to clean outside of burners. This is to make sure all the burner ports are fully open.

⚠ CAUTION: Do not enlarge the burner ports when cleaning.

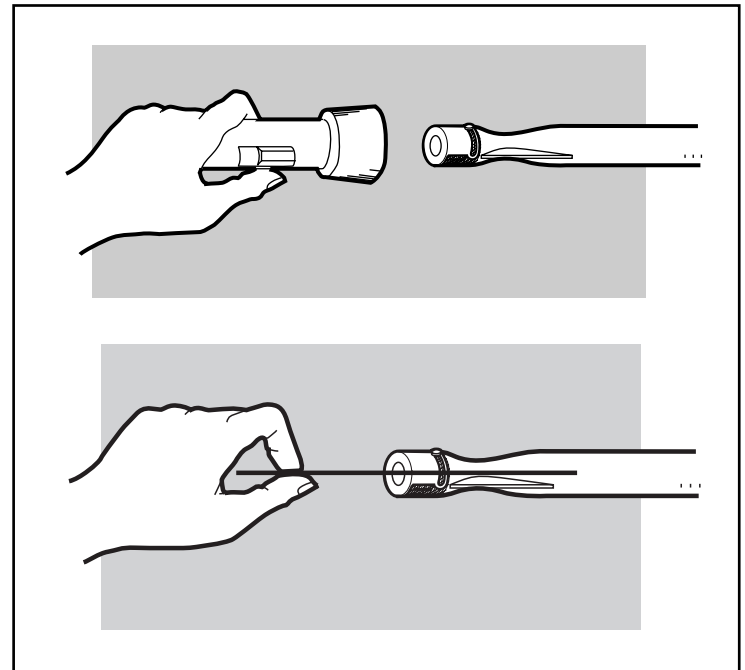

REPLACING MAIN BURNERS

- 1) Your Weber® gas barbecue must be OFF and cool.
- 2) Turn gas OFF at source.
- 3) To remove control panel: take off the burner control knobs. Remove the screws holding the control panel in place. Lift off the control panel.
- 4) Unhook the manifold bracket(1) and unscrew the two wing nuts(2) that hold the manifold to the cooking box. Pull the manifold and valve assembly out of the burners and carefully set it down.

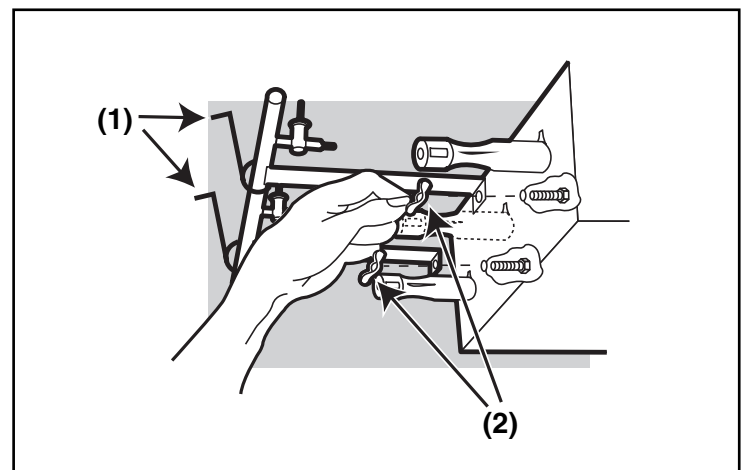

- 5) Slide the burner assembly out from under the guide screw and washer(1) in the corners of the cooking box.
 - 6) Lift and twist the burner assembly slightly, to separate the crossover tube(1) from the burners. Remove the burners from the cooking box.
 - 7) To reinstall the burners, reverse 3) through 7).
- ⚠ CAUTION: The burner openings(1) must be positioned properly over the valve orifices(2).**
- Check proper assembly before fastening manifold in place.

⚠ WARNING: After reinstalling the gas lines, they should be leak checked with a soap and water solution before using the barbecue. (See Step: "Check for gas leaks.")

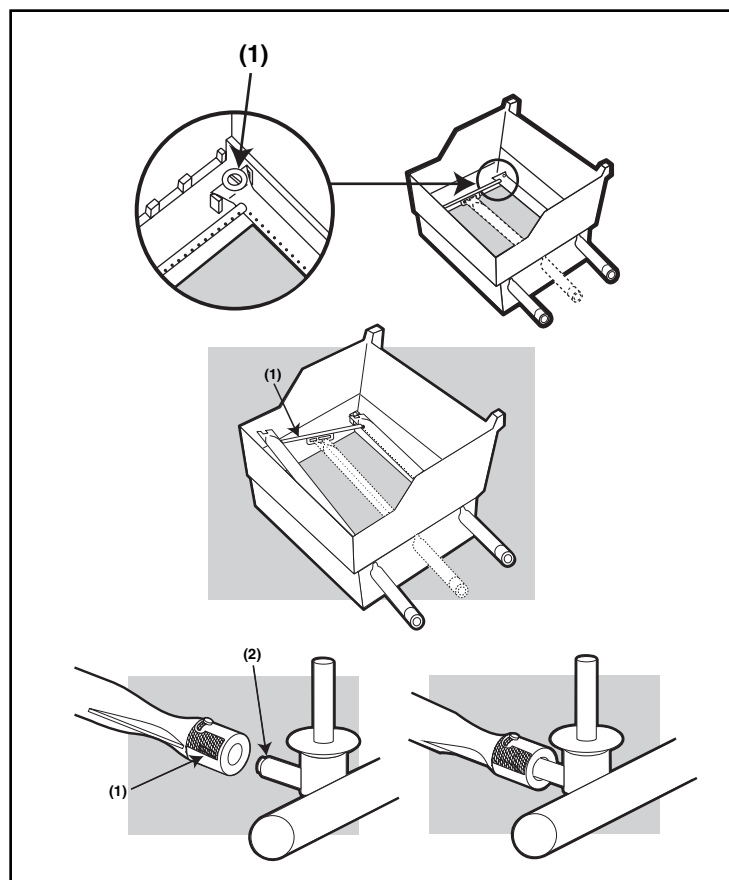

CROSSOVER® IGNITION SYSTEM OPERATIONS

If the Crossover® ignition system fails to ignite the Left burner, light the Left burner with a match. If the Left burner lights with a match, then check the Crossover® ignition system.

- Check that both the white(1) and black(2) ignition wires are attached properly.
- Check that the Crossover® ignition button pushes the igniter (button) down, and returns to the up position.

If the Crossover® ignition system still fails to light, contact the Customer Service Representative in your area using the contact information on our web site. Log onto www.weber.com®.

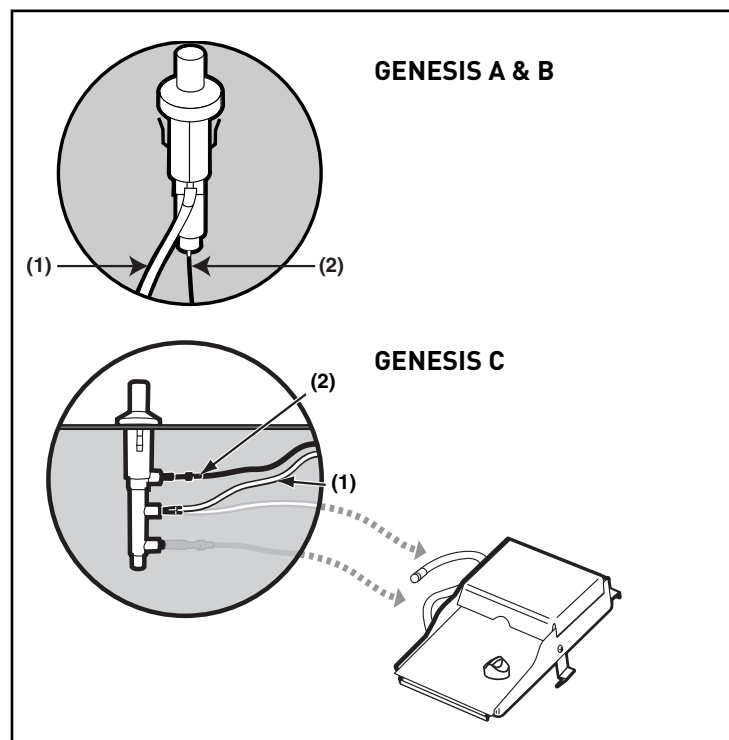



WEBER-STEPHEN PRODUCTS CO.
www.weber.com[®]

©2003 The following trademarks are registered in the name of Weber-Stephen Products Co., an Illinois corporation, located at 200 East Daniels Road, Palatine, Illinois 60067 U.S.A. Australia: Smokey Joe, Weber, Kettle Silhouette[®], Genesis, Austria; Kettle Silhouette[®], Smokey Joe, Weber, Benelux; Kettle Silhouette[®], Smokey Joe, Weber, Compact Grill Configuration, Botswana; Weber, Canada; Smokey Joe, Genesis, China; Kettle Silhouette[®], Denmark; Kettle Silhouette[®], Smokey Joe, Weber, Finland; Smokey Joe, France; Kettle Silhouette[®], Smokey Joe, Weber, One-Touch, Germany; Smokey Joe, Weber, One-Touch, Greece; Smokey Joe, Ireland; Kettle Silhouette[®], Smokey Joe, Italy; Smokey Joe, Weber, Japan; Smokey Joe, Weber, Korea; Smokey Joe, Weber, New Zealand; Weber, Smokey Joe, Nigeria; Weber, Norway; Smokey Joe, Weber, Portugal; Weber, South Africa; Smokey Joe, Weber, Kettle Configuration, Spain; Smokey Joe, Weber, Sweden; Kettle Silhouette[®], Smokey Joe, Switzerland; Kettle Silhouette[®], Smokey Joe, Weber, United Kingdom; Smokey Joe, Weber, Weber One-Touch, U.S.A.; Kettle Configuration, Kettle Silhouette[®], Smokey Joe, Weber, One-Touch, Firespice, Go-Anywhere, U.S.A.; Kettle Configuration, Kettle Silhouette, Genesis, Flavorizer, Crossover, Flamgo, Performer, Rapidfire, Tuck 'N Carry, Jumbo Joe, Bar-B-Kettle, Master-Touch, Spirit, Grill Out, Summit, Platinum, 1-800-Grill-Out, Ranch, Matchless Flame, Zimbabwe; Weber, Kettle Configuration, Kettle Silhouette[®].