

This Owner's Manual is provided and hosted by [Appliance Factory Parts](http://www.appliancefactoryparts.com).



# Weber GENESIS SILVER B SWE (2005) Owner's Manual

[Shop genuine replacement parts for Weber GENESIS  
SILVER B SWE \(2005\)](#)



[Find Your Weber Grill Parts - Select From 2037 Models](#)

----- Manual continues below -----

# GENESIS® GAS GRILL



## LP Gas Grill Owner's Guide

#55826



**YOU MUST READ THIS OWNERS GUIDE  
BEFORE OPERATING YOUR GAS GRILL**

**⚠ DANGER**

If you smell gas:

1. Shut off gas to the appliance.
  2. Extinguish any open flames.
  3. Open lid
  4. If odor continues, keep away from the appliance and immediately call your gas supplier or your fire department.
- Leaking gas may cause a fire or explosion which can cause serious bodily injury or death, or damage to property.

**⚠ WARNING**

1. Do not store spare liquid propane cylinder within 10 feet (3m) of this appliance.
2. Do not store or use gasoline or other flammable liquids or vapors within 25 feet (8m) of this appliance.

**⚠ WARNING:** Follow all leak-check procedures carefully in this manual prior to barbecue operation. Do this even if the barbecue was dealer-assembled.

**NOTICE TO INSTALLER:** These instructions must be left with the owner and the owner should keep them for future use.

**THIS GAS APPLIANCE IS DESIGNED FOR  
OUTDOOR USE ONLY.**

**⚠ WARNING:** Do not try to light this appliance without reading the "Lighting" Instructions section of this manual.



55826 US 10/03/04  
LP  
US ENGLISH

# CONTENTS

<b>DANGERS AND WARNINGS</b> .....	<b>3</b>
<b>WARRANTY</b> .....	<b>4</b>
<b>GENERAL INSTRUCTIONS</b> .....	<b>5</b>
For Installation in Canada .....	5
Operating .....	5
Storage and/or Nonuse .....	5
Cooking .....	6
Cleaning .....	6
<b>GAS INSTRUCTIONS</b> .....	<b>7</b>
Important LP Cylinder Information .....	7
Connecting the Liquid Propane Cylinder .....	7
Check that all burner valves are off .....	7
Remove control panel and burner control knobs .....	8
Check for gas leaks .....	9
Refilling the Liquid Propane Cylinder .....	10
Checking the fuel level in your tank .....	10
Safe handling tips for Liquid Propane Gas Cylinders .....	11
<b>OPERATING INSTRUCTIONS</b> .....	<b>12</b>
Lighting .....	12
Manual Lighting .....	13
Lighting the Side Burner .....	14
<b>TROUBLESHOOTING</b> .....	<b>15</b>
<b>SIDE BURNER TROUBLESHOOTING</b> .....	<b>16</b>
Side Burner maintenance .....	16
<b>MAINTENANCE</b> .....	<b>17</b>
Weber® Spider /Insect screens .....	17
Annual Maintenance .....	17
Main Burner Flame Pattern .....	18
Main Burner Cleaning Procedure .....	18
Replacing Main Burners .....	18
Crossover® Ignition System Operations .....	19

## ⚠DANGER

Failure to follow the Dangers, Warnings and Cautions contained in this Owner's Manual may result in serious bodily injury or death, or in a fire or an explosion causing damage to property.

## ⚠WARNINGS

- ⚠ Do not store a spare or disconnected liquid propane cylinder under or near this barbecue.
- ⚠ Improper assembly may be dangerous. Please follow the assembly instructions carefully.
- ⚠ After a period of storage, and/or nonuse, the Weber® gas barbecue should be checked for gas leaks and burner obstructions before use. See instructions in this manual for correct procedures.
- ⚠ Do not operate the Weber® gas barbecue if there is a gas leak present.
- ⚠ Do not use a flame to check for gas leaks.
- ⚠ Combustible materials should never be within 24 inches of the top, bottom, back or sides of your Weber® gas barbecue.
- ⚠ Do not put a barbecue cover or anything flammable on, or in the storage area under the barbecue.
- ⚠ Your Weber® gas barbecue should never be used by children. Accessible parts of the barbecue may be very hot. Keep young children away while it is in use.
- ⚠ You should exercise reasonable care when operating your Weber® gas barbecue. It will be hot during cooking or cleaning and should never be left unattended, or moved while in operation.
- ⚠ Should the burners go out while in operation, turn all gas valves off. Open the lid and wait five minutes before attempting to relight, using the lighting instructions.
- ⚠ Do not use charcoal or lava rock in your Weber® gas barbecue.
- ⚠ Never lean over open grill or place hands or fingers on the front edge of the cooking box.
- ⚠ Should a grease fire occur, turn off all burners and leave lid closed until fire is out.
- ⚠ Do not enlarge valve orifices or burner ports when cleaning the valves or burners.
- ⚠ The Weber® gas barbecue should be thoroughly cleaned on a regular basis.
- ⚠ Liquid propane gas is not natural gas. The conversion or attempted use of natural gas in a liquid propane unit or liquid propane gas in a natural gas unit is dangerous and will void your warranty.
- ⚠ Do not attempt to disconnect any gas fitting while your barbecue is in operation.
- ⚠ Use heat-resistant barbecue mitts or gloves when operating barbecue.
- ⚠ Keep any electrical supply cord and the fuel supply hose away from any heated surfaces.
- ⚠ Combustion byproducts produced when using this product contain chemicals known to the state of California to cause cancer, birth defects, or other reproductive harm.
- ⚠ Do not use this barbecue unless all parts are in place. The unit must be properly assembled according to the instructions outlined in the "Assembly Instruction" section of the Owner's Guide.

### LIQUID PROPANE GAS UNITS ONLY:

- ⚠ Use the regulator that is supplied with your Weber® gas barbecue.
- ⚠ Do not attempt to disconnect the gas regulator or any gas fitting while your barbecue is in operation.
- ⚠ A dented or rusty liquid propane cylinder may be hazardous and should be checked by your liquid propane supplier. Do not use a liquid propane cylinder with a damaged valve.
- ⚠ Although your liquid propane cylinder may appear to be empty, gas may still be present, and the cylinder should be transported and stored accordingly.
- ⚠ If you see, smell or hear the hiss of escaping gas from the liquid propane cylinder:
  1. Move away from liquid propane cylinder.
  2. Do not attempt to correct the problem yourself.
  3. Call your fire department.

# 4

# WARRANTY

Weber-Stephen Products Co. (Weber) hereby warrants to the ORIGINAL PURCHASER of this Weber® gas grill that it will be free of defects in material and workmanship from the date of purchase as follows:

Aluminum Castings, lifetime,	1 year paint
Stainless Steel Hood Section,	25 years
Porcelain Hood Section,	25 years
Burners,	10 years
Igniter,	3 years
Porcelain Enameled	
Cooking Grates,	3 years no rust through
Porcelain Enameled Cast Iron	
Cooking Grates,	5 years no rust through
Stainless Steel Cooking Grates,	7 years no rust through
Porcelain Enameled	
Flavorizer® Bars,	1 year no rust through
Stainless Steel	
Flavorizer® Bars,	5 year no rust through
Thermoplastic/Thermoset Parts,	10 years Excluding fading
Rotisserie and all related components,	1 year
All Remaining Parts,	5 years

There are no other express warrants except as set forth herein and any applicable implied warranties of merchantability and fitness are limited in duration to the period of coverage of this express written Limited Warranty. Some regions do not allow limitation on how long an implied warranty lasts, so this limitation may not apply to you.

Weber is not liable for any special, indirect or consequential damages. Some regions do not allow the exclusion or limitation of incidental or consequential damages, so this limitation or exclusion may not apply to you.

Weber does not authorize any person or company to assume for it any other obligation or liability in connection with the sale, installation, use, removal, return, or replacement of its equipment; and no such representations are binding on Weber.

This Warranty applies only to products sold at retail.

## **WEBER-STEPHEN PRODUCTS CO.**

**Customer Service Center**  
**1890 Roselle Road, Suite 308**  
**Schaumburg, IL 60195**  
**USA**

### **For replacement parts call:**

**1-800-446-1071**  
**[www.weber.com](http://www.weber.com)**

when assembled and operated in accordance with the printed instructions accompanying it.

Weber may require reasonable proof of your date of purchase. **THEREFORE, YOU SHOULD RETAIN YOUR SALES SLIP OR INVOICE.**

This Limited Warranty shall be limited to the repair or replacement of parts that prove defective under normal use and service and which on examination shall indicate, to Weber's satisfaction, they are defective. Before returning any parts, contact the Customer service representative in your area using the contact information on our website. If Weber confirms the defect and approves the claim, Weber will elect to replace such parts without charge.

If you are required to return defective parts, transportation charges must be prepaid. Weber will return parts to the purchaser, freight or postage prepaid.

This Limited Warranty does not cover any failures or operating difficulties due to accident, abuse, misuse, alteration, misapplication, vandalism, improper installation or improper maintenance or service, or failure to perform normal and routine maintenance, including but not limited to damage caused by insects within the burner tubes, as set out in this owner's manual.

Deterioration or damage due to severe weather conditions such as hail, hurricanes, earthquakes or tornadoes, discoloration due to exposure to chemicals either directly or in the atmosphere, is not covered by this Limited Warranty.

Your Weber® gas barbecue is a portable outdoor cooking appliance. With the Weber® gas barbecue you can grill, barbecue, roast and bake with results that are difficult to duplicate with indoor kitchen appliances. The closed lid and Flavorizer® Bars produce that “outdoor” flavor in the food. The Weber® gas barbecue is portable so you can easily change its location in your yard or on your patio. Portability means you can take your Weber® gas barbecue with, if you move. Liquid Propane (LP) gas supply is easy to use and gives you more cooking control than charcoal fuel.

- These instructions will give you the minimum requirements for assembling your Weber® gas barbecue. Please read the instructions carefully before using your Weber® gas barbecue. Improper assembly can be dangerous.
- Not for use by children.
- If there are local codes that apply to portable gas grills, you will have to conform to them. If there are no local codes, you must conform to the latest edition of the National Fuel Gas Code: ANSI Z 223.1/NFPA 54, or CAN/CGA-B149.1, Natural Gas and Propane Installation Code.
- The pressure regulator supplied with the Weber® gas barbecue must be used. This regulator is set for 10.5 inches of water column (pressure).
- This Weber® gas barbecue is designed for use with liquid propane (LP) gas only. Do not use with natural (piped in city) gas. The valves, orifices, hose and regulator are for LP gas only.
- Do not use with charcoal fuel.
- Check that the area under the control panel and the bottom tray are free from debris that might obstruct the flow of combustion or ventilation air.
- The areas around the LP cylinder must be free and clear from debris.
- Replacement pressure regulators and hose assemblies must be those specified by the outdoor cooking gas appliance manufacturer.

## FOR INSTALLATION IN CANADA

These instructions, while generally acceptable, do not necessarily comply with the Canadian Installation codes, particularly with piping above and below ground. In Canada the installation of this appliance must comply with local codes and/or Standard CAN/CGA-B149.2 (Installation Code for Propane Burning Appliances and Equipment).

## STORAGE AND/OR NONUSE

- The gas must be turned off at the liquid propane cylinder when the Weber® gas barbecue is not in use.
- When the Weber® gas barbecue is stored indoors, the gas supply must be DISCONNECTED and the LP cylinder stored outdoors in a well-ventilated space.
- LP cylinder must be stored outdoors in a well-ventilated area out of reach of children. Disconnected LP cylinder must not be stored in a building, garage or any other enclosed area.
- When the LP cylinder is not disconnected from the Weber® gas barbecue, the appliance and LP tank must be kept outdoors in a well-ventilated space.
- The Weber® gas barbecue should be checked for gas leaks and any obstructions in the burner tubes before using. (See Sections: “General Maintenance and Annual Maintenance.”)
- Check that the areas under the control panel and the slide out bottom tray are free from debris that might obstruct the flow of combustion or ventilation air.
- The Spider /Insect Screens should also be checked for any obstructions. (See Section: “Annual Maintenance.”)

## OPERATING

- ⚠ **WARNING: Only use this barbecue outdoors in a well-ventilated area. Do not use in a garage, building, breezeway or any other enclosed area.**
- ⚠ **WARNING: Your Weber® gas barbecue shall not be used under overhead combustible construction.**
- ⚠ **WARNING: Your Weber® gas barbecue is not intended to be installed in or on recreational vehicles and/or boats.**
- ⚠ **WARNING: Do not use the barbecue within 24 inches of combustible materials, top, bottom, back or sides of the grill.**
- ⚠ **WARNING: The entire cooking box gets hot when in use. Do not leave unattended.**
- ⚠ **WARNING: Keep any electrical supply cord and the fuel supply hose away from any heated surface.**
- ⚠ **WARNING: Keep the cooking area clear of flammable vapors and liquids such as gasoline, alcohol, etc., and combustible materials.**
- ⚠ **WARNING: Never store an extra (spare) LP cylinder under or near the Weber® gas barbecue.**
- ⚠ **WARNING: The LP cylinder used with your barbecue must be with an OPD (Overfilling Prevention Device) and a QCC1 or Type 1 (CGA810) cylinder connection. The cylinder connection must be compatible with the barbecue connection.**

# 6

## GENERAL INSTRUCTIONS

### COOKING

**⚠ WARNING: Do not move the Weber® gas barbecue when operating or while barbecue is hot.**

You can adjust the FRONT and BACK burners as desired. The control settings: High (H), Medium (M), Low (L), or Off (O) are described in your Weber® cookbook. The cookbook uses these notations to describe the settings of the FRONT and BACK burners. For example, to sear steaks, you would set all burners at H (high). Then to complete cooking, you would set FRONT and BACK at M (medium). Refer to your Weber® cookbook for detailed cooking instructions.

*Note: The temperature inside your cooking box for the first few uses, while surfaces are still very reflective, may be hotter than those shown in your cookbook. Cooking conditions. Such as wind and weather, may require the adjustment of the burner controls to obtain the correct cooking temperatures.*

**If burners go out during cooking, open lid, turn off all burners and wait five minutes before relighting.**

**Preheating** - Your Weber® gas barbecue is an energy-efficient appliance. It operates at an economical low BTU rate. To preheat: after lighting, close lid and turn all burners to high (HH). Preheating to between 500° and 550° F (260° and 290° C) will take 10 to 15 minutes depending on conditions such as air temperature and wind.

**Drippings and grease** - The Flavorizer® bars are designed to “smoke” the correct amount of drippings for flavorful cooking. Excess drippings and grease will accumulate in the catch pan under the slide out bottom tray. Disposable foil drip pans are available that fit the catch pan.

**⚠ WARNING: Check the bottom tray for grease build-up before each use. Remove excess grease to avoid a grease fire in the slide out bottom tray.**

### CLEANING

**⚠ WARNING: Turn your Weber® gas barbecue OFF and wait for it to cool before cleaning.**

**⚠ CAUTION: Do not clean your Flavorizer® bars or cooking grates in a self-cleaning oven.**

**For availability of replacement cooking grates and Flavorizer® bars Contact the Customer Service Representative in your area using the contact information on our web site. Log onto [www.weber.com](http://www.weber.com).**

**Outside surfaces** - Use a warm soapy water solution to clean, then rinse with water.

**⚠ CAUTION: Do not use oven cleaner, abrasive cleansers (kitchen cleansers) cleaners that contain citrus products, or abrasive cleaning pads on barbecue or cart surfaces.**

**Slide out Bottom tray** - Remove excess grease, then wash with warm soapy water, then rinse

**Flavorizer® bars and Cooking grates** - Clean with a suitable brass bristle brush. As needed, remove from grill and wash with warm soapy water, then rinse with water.

**Catch pan** - Disposable foil trays are available, or you can line the catch pan with aluminum foil. To clean the catch pan, wash with warm soapy water, then rinse.

**Thermometer** - Wipe with warm soapy water; clean with plastic scrub ball. Do not put in dishwasher or submerge in water.

**Inside cooking module** - Brush any debris off of burner tubes. **DO NOT ENLARGE BURNER PORTS (OPENINGS).** Wash inside of cooking box with warm soapy water and a water rinse.

**Inside Lid** - While lid is warm, wipe inside with paper towel to prevent grease build-up. Flaking built-up grease resembles paint flakes.

**Stainless steel surfaces** - Wash with a soft cloth and a soap and water solution. Be careful to scrub with the grain direction of the stainless steel.

**Thermoset surfaces** - Wash with a soft cloth and a soap and water solution.

**Do not use cleaners that contain acid, mineral spirits or xylene. Rinse well after cleaning.**

**Thermoset work surfaces are not to be used as cutting boards.**

## IMPORTANT LP CYLINDER INFORMATION

Failure to follow these **DANGER** statements exactly may result in a fire causing death or serious injury.

### ⚠ DANGER

- ⚠ **NEVER** store a spare LP Cylinder under or near this barbecue.
- ⚠ **NEVER** fill the tank beyond 80% full.

Your Weber® gas grill is equipped for a cylinder supply system designed for vapor withdrawal.

- ⚠ **WARNING:** Only use this grill outdoors in a well-ventilated area. Do not use in a garage, building, breezeway or any other enclosed area.

The proper filling methods for the filling of your cylinder are by weight or volume, as described in NFPA 58. Please make sure your filling station fills your LP cylinder by weight or volume. Ask your filling station to read purging and filling instructions on the LP cylinder before attempting to fill.

## CHECK THAT ALL BURNER VALVES ARE OFF

Valves are shipped in the OFF position, but you should check to be sure that they are turned OFF. Check by pushing down and turning clockwise. If they do not turn, they are off. Proceed to the next step. If they do turn continue turning them clockwise until they stop, then they are off. Proceed to the next step.

## CONNECTING THE LIQUID PROPANE CYLINDER

- ⚠ **WARNING:** Make sure that the LP cylinder valve is closed. Close by turning valve clockwise.

### ⚠ DANGER

Do not use an open flame to check for gas leaks. Be sure there are no sparks or open flames in the area while you check for leaks. Sparks or flames will result in a fire or explosion which can cause serious bodily injury or death, and damage to property.

Some LP tanks have differing top collar assemblies. (The top collar is the metal protective ring around the valve.) One series of tanks mount with the valve facing front. The other tanks mount with the valve facing away from the fuel scale. These types of tanks are illustrated below.

You will need: LP cylinder, a soap and water solution and a rag or brush to apply it.

- 1) Turn the LP cylinder so the opening of the valve is either to the front, side or rear of the Weber® gas barbecue. Lift and hook the cylinder onto the fuel gauge.
- 2) Loosen the cylinder lock wing nut. Swing the cylinder lock down. Tighten the wing nut.

### To Connect the hose to the cylinder:

- 3) Remove the plastic dust cover from the valve.
- 4) Screw the regulator coupling onto the tank valve, clockwise, or to the right. Hand-tighten only.

*Note: This is a new type of connection. It tightens clockwise and will not allow gas to flow unless the connection is tight. The connection requires tightening by hand only.*

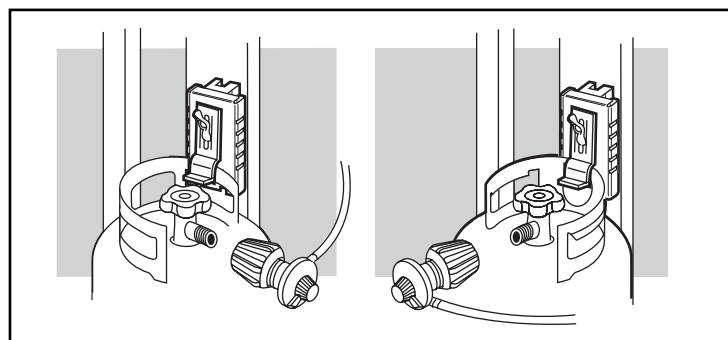
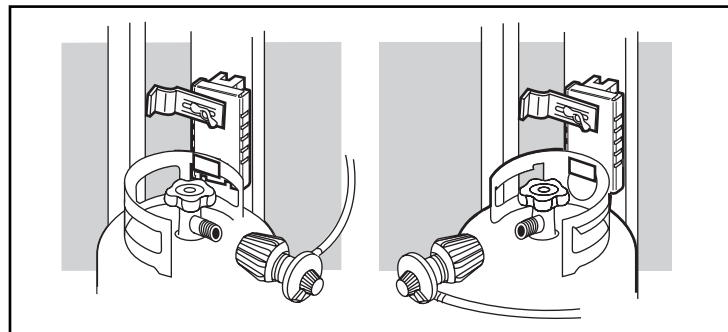

# 8

## GAS INSTRUCTIONS

**⚠ WARNING: Do not use a wrench to tighten the connection. Using a wrench could damage the regulator coupling and could cause a leak.**

- 5) Mix soap and water.
- 6) Turn on the cylinder valve.
- 7) Check for leaks by wetting the fitting with the soap and water solution and watching for bubbles. If bubbles form, or if a bubble grows, there is a leak.

If there is a leak, turn off the gas and tighten the fitting. Turn the gas back on and recheck with the soap and water solution.

If leak does not stop, Contact the Customer Service Representative in your area using the contact information on our web site. Log onto [www.weber.com](http://www.weber.com)®. Do not use the barbecue.

- 8) When leak checking is complete, turn gas supply OFF at the source and rinse connections with water.

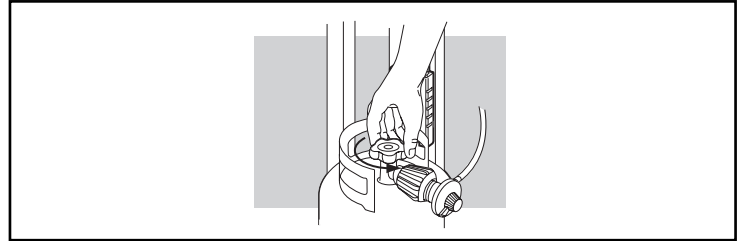
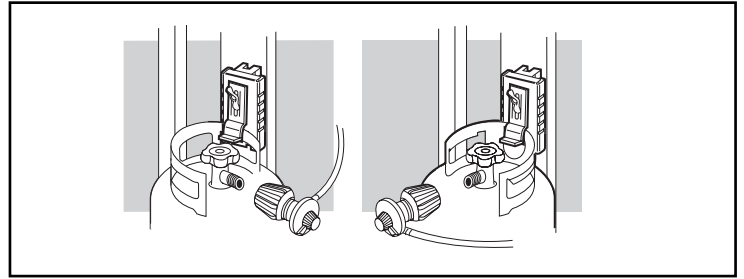

### REMOVE CONTROL PANEL AND BURNER CONTROL KNOBS

*You will need: Phillips screwdriver.*

- 1) Remove control knobs.

### SILVER, GOLD AND PLATINUM C MODELS

- 2a) Unhook side burner from Cookbox Frame.
- 2) Remove screws with a Phillips screwdriver
- 3) Pull up igniter button until it sticks in the up position and remove control panel from grill.
- 4) Replace control panel when Leak Check is completed.

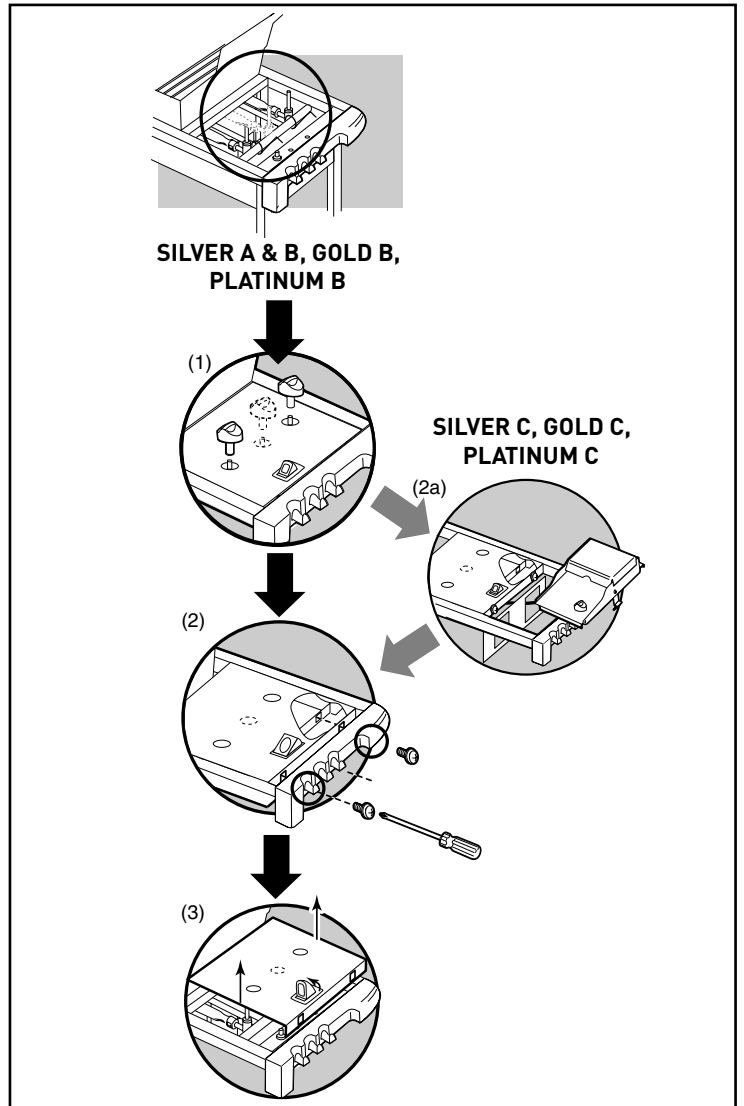

## CHECK FOR GAS LEAKS

### ⚠ DANGER

**Do not use an open flame to check for gas leaks. Be sure there are no sparks or open flames in the area while you check for leaks. Sparks or open flames will result in a fire or explosion, which can cause serious bodily injury or death and damage to property.**

### ⚠ WARNING: You should check for gas leaks every time you disconnect and reconnect a gas fitting.

*Note - All factory-made connections have been thoroughly checked for gas leaks. The burners have been flame-tested. As a safety precaution however, you should recheck all fittings for leaks before using your Weber Gas Barbecue. Shipping and handling may loosen or damage a gas fitting.*

### ⚠ WARNING: Perform these leak checks even if your barbecue was dealer or store assembled.

*You will need: a soap and water solution, and a rag or brush to apply it.*

*Note - Since some leak test solutions, including soap and water, may be slightly corrosive, all connections should be rinsed with water after checking for leaks.*

Make sure side burner is OFF.

To perform leak checks: open cylinder valve by turning the cylinder valve hand-wheel counterclockwise.

### ⚠ WARNING: Do not ignite burners when leak checking. Check for leaks by wetting the connections with the soap and water solution and watching for bubbles. If bubbles form or if a bubble grows, there is a leak.

#### Check:

- 1) Hose-to-manifold connection.
- 2) Regulator-to-Cylinder connection.

⚠ **WARNING: If there is a leak at connection (1), retighten the fitting with a wrench and recheck for leaks with soap and water solution. If a leak persists after retightening the fitting, turn OFF the gas. DO NOT OPERATE THE GRILL. Contact the Customer Service Representative in your area using the contact information on our web site. Log onto [www.weber.com](http://www.weber.com).**

#### Check:

- 3) Valves-to-manifold connections.
- 4) The hose-to-regulator connection.

⚠ **WARNING: If there is a leak at connections (2), (3) or (4), turn OFF the gas. DO NOT OPERATE THE GRILL. Contact the Customer Service Representative in your area using the contact information on our web site. Log onto [www.weber.com](http://www.weber.com).**

When leak checks are complete, turn gas supply OFF at the source and rinse connections with water.

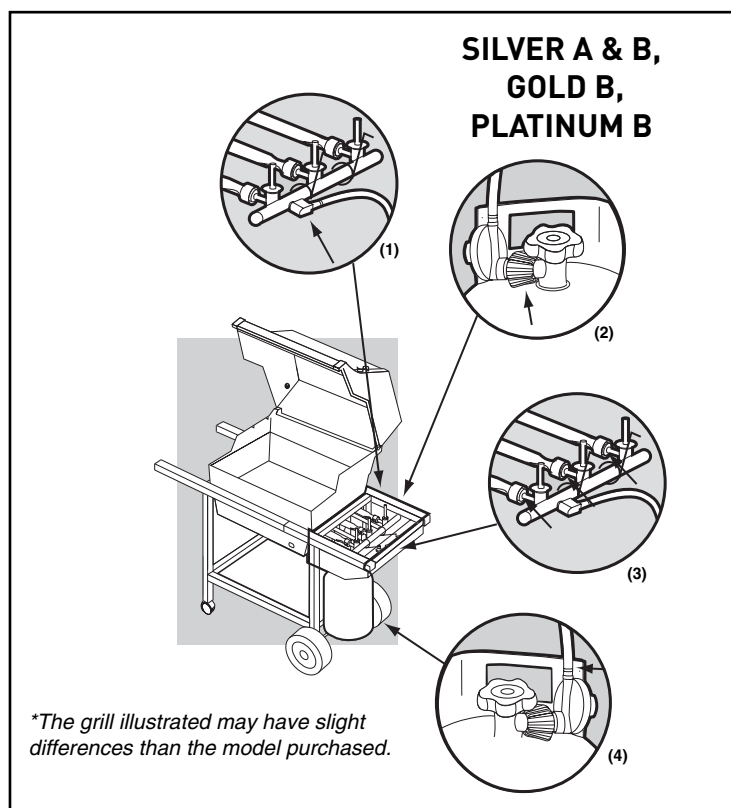

# 10

## GAS INSTRUCTIONS

Check:

1) Hose to manifold connection.

**⚠ WARNING: If there is a leak at connection (1), retighten the fitting with a wrench and recheck for leaks with soap and water solution. If a leak persists after re-tightening the fitting, turn OFF the gas. DO NOT OPERATE THE GRILL. Contact the Customer Service Representative in your area using the contact information on our web site. Log onto [www.weber.com](http://www.weber.com).**

2) Regulator to cylinder connection.

3) Manifold to side burner hose connection.

4) Side burner hose to side burner connection, side burner valve and orifice connections

5) Valves to manifold connections.

6) Hose to regulator connection.

**⚠ WARNING: If there is a leak at connections (2,3,4,5 or 6), turn OFF the gas. DO NOT OPERATE THE GRILL. Contact the Customer Service Representative in your area using the contact information on our web site. Log onto [www.weber.com](http://www.weber.com).**

When leak checks are complete, turn gas supply OFF at the source and rinse connections with water.

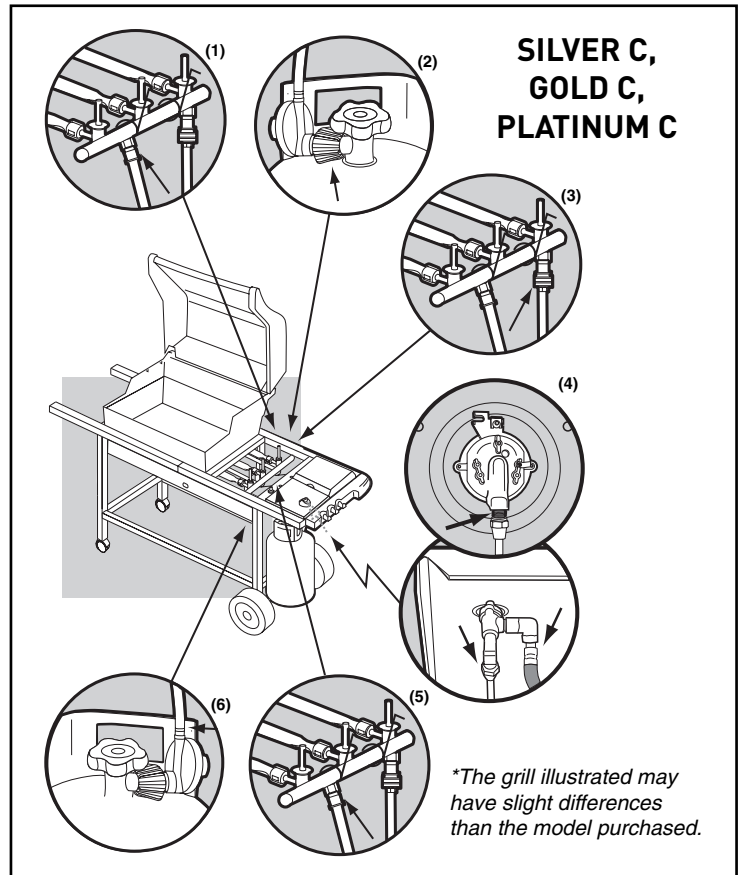

### REFILLING THE LIQUID PROPANE CYLINDER

We recommend that you refill the LP cylinder before it is completely empty.

#### Removal of the LP cylinder

- 1) Close cylinder valve (turn clockwise).
- 2) Unscrew regulator coupling by turning counterclockwise, by hand only.
- 3) Loosen cylinder lock wing nut and turn cylinder lock up out of the way.
- 4) Lift cylinder off.

To refill, take LP cylinder to a "Gas Propane" dealer.

**⚠ WARNING: We recommend that your LP cylinder be filled at an authorized LP gas dealer, by a qualified attendant, who fills the cylinder by weight. IMPROPER FILLING IS DANGEROUS.**

**⚠ CAUTION: When transporting the LP cylinder make sure the plastic dust cover is in place over the valve. This will keep dust and dirt from the threaded portion of the valve.**

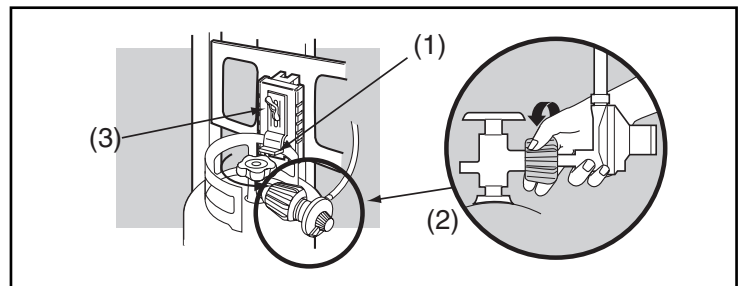

### CHECKING THE FUEL LEVEL IN YOUR TANK

Check the fuel level by viewing the color indicator level line on the side of the tank scale.

- 1) Empty
- 2) Medium
- 3) Full

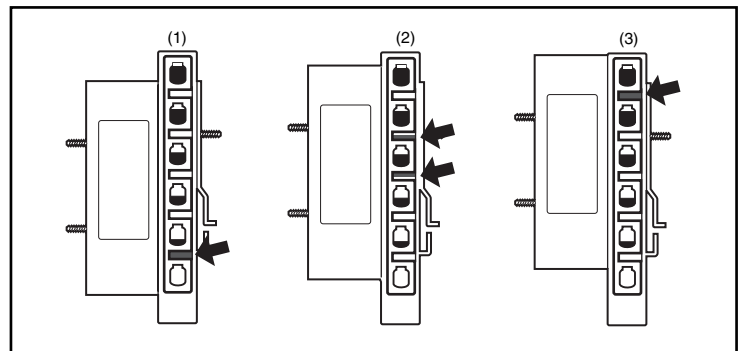

## SAFE HANDLING TIPS FOR LIQUID PROPANE GAS CYLINDERS

- Liquid Propane (LP) gas is a petroleum product as are gasoline and natural gas. LP gas is a gas at regular temperatures and pressures. Under moderate pressure, inside a cylinder, LP gas is a liquid. As the pressure is released, the liquid readily vaporizes and becomes gas.
- LP gas has an odor similar to natural gas. You should be aware of this odor.
- LP gas is heavier than air. Leaking LP gas may collect in low areas and prevent dispersion.
- To fill, take the LP cylinder to an RV center, or look up “gas-propane” in the phone book for other sources of LP gas.

**⚠ WARNING: We recommend that your LP cylinder be filled at an authorized LP gas dealer, by a qualified attendant, who fills the tank by weight. IMPROPER FILLING IS DANGEROUS.**

- Air must be removed from a new LP cylinder before the initial filling. Your LP dealer is equipped to do this.
- The LP cylinder must be installed, transported and stored in an upright position. LP cylinders should not be dropped or handled roughly.
- Never store or transport the LP cylinder where temperatures can reach 125° F (too hot to hold by hand - for example: do not leave the LP cylinder in a car on a hot day).

*Note - A refill will last about 20 hours of cooking time at normal use. The fuel scale will indicate the propane supply so you can refill before running out. You do not have to run out before you refill.*

- Treat “empty” LP cylinders with the same care as when full. Even when the LP tank is empty of liquid there still may be gas pressure in the cylinder. **Always close the cylinder valve before disconnecting.**

**⚠ CAUTION: When transporting the LP cylinder make sure the plastic dust cover is in place over the valve. This will keep dust and dirt from the threaded portion of the valve.**

- Do not use a damaged LP cylinder. Dented or rusty LP cylinders or LP cylinders with a damaged valve may be hazardous and should be replaced with a new one immediately.

### Liquid Propane (LP) Cylinder(s)

- The joint where the hose connects to the LP cylinder must be leak tested each time the LP cylinder is reconnected. For example, test each time the LP cylinder is refilled.

- Be sure the regulator is mounted with the small vent hole pointed downward so that it will not collect water. This vent should be free of dirt, grease, bugs etc.
- The gas connections supplied with your Weber® gas barbecue have been designed and tested to meet 100% CSA and ANSI requirements.

**⚠ WARNING: Replacement LP tanks must match the regulator connection supplied with this barbecue.**

### Liquid Propane Cylinder requirements

- Check to be sure cylinders have a D.O.T. certification (1), and date tested (2) is within five years. Your LP gas supplier can do this for you.
- All LP tank supply systems must include a collar to protect the cylinder valve.
- The LP cylinder must be a 20-lb. size approximately (18 1/4 inches high, 12 1/4 inches in diameter).
- The cylinder should be constructed and marked in accordance with the Specifications for LP - Gas Cylinders of the U.S. Department of Transportation (D.O.T.) or the National Standard of Canada, CAN/CSA-B339, Cylinders, Spheres and Tubes or Transportation of Dangerous Goods; and Commission, as applicable.

### In Canada

### Liquid Propane Cylinder requirements

*Note: Your retailer can help you match a replacement tank to your barbecue*

- The LP cylinder must be constructed and marked in accordance with the specifications for LP gas cylinders, T.C.

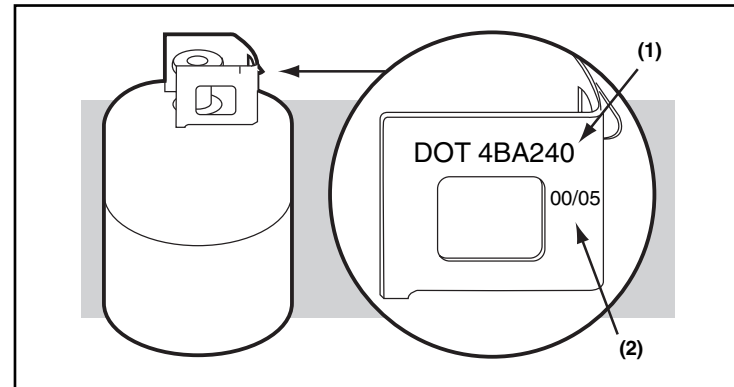

# 12

# OPERATING INSTRUCTIONS

## LIGHTING

Summary lighting instructions are on the control panel.

### ⚠ DANGER

Failure to open the lid while igniting the barbecue's burners, or not waiting 5 minutes to allow the gas to clear if the barbecue does not light, may result in an explosive flame-up which can cause serious bodily injury or death.

### Crossover® Ignition System

Note - The Crossover® ignition system ignites the Front burner with a spark from the igniter electrode inside the Gas Catcher™ ignition chamber. You generate the energy for the spark by pushing the Crossover® ignition button until it clicks.

⚠ **WARNING:** Check hose before each use of barbecue for nicks, cracking, abrasions or cuts. If the hose is found to be damaged in any way, do not use the barbecue. Replace using only Weber® authorized replacement hose. Contact the Customer Service Representative in your area using the contact information on our web site. Log onto [www.weber.com](http://www.weber.com)®.

- 1) Open the lid.
- 2) Make sure all burner control knobs are turned OFF. (Push control knob down and turn clockwise to ensure that it is in the OFF position.)

⚠ **WARNING:** The burner control knobs must be in the OFF position before turning on the liquid propane cylinder tank valve. If they are not in the OFF position, when you turn on the LP cylinder valve, the “excess gas flow control” feature will activate, limiting the flow of gas from the LP cylinder. If this should occur, turn OFF the LP cylinder valve and burner control knobs. Then start over.

### ⚠ DANGER:

When the “excess gas flow control” feature is activated, a small amount of gas is still flowing to the burners. After turning OFF the cylinder valve, wait at least 5 minutes for the gas to clear before attempting to light the barbecue. Failure to do so may result in an explosive flame-up, which can cause serious bodily injury or death.

- 3) Turn the cylinder on by slowly turning the cylinder valve counterclockwise.
- ⚠ **WARNING:** Do not lean over the open barbecue. Keep your face and body at least one foot away from the matchlight hole when lighting the barbecue.
- 4) Push Front burner control knob down and turn to START/HI.
- 5) Push the Crossover® ignition button several times, so it clicks each time.
- 6) Check that the burner is lit by looking through the matchlight hole on the front of the cooking box. You should see a flame.
- ⚠ **WARNING:** If the burner does not light, turn the Front burner control knob to OFF and wait 5 minutes to let the gas clear before you try again or try to light with a match.
- 7) After the FRONT burner is lit you can turn on the other burner or burners.

Note - Always light the FRONT burner first. The other burner or burners ignite from the FRONT burner.

## MAIN BURNER LIGHTING

### SILVER A & B

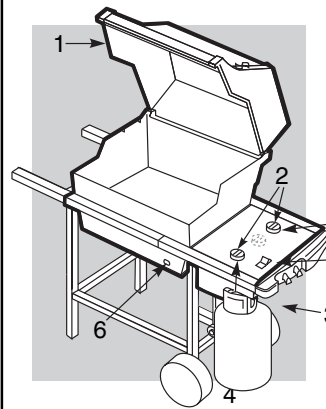

### SILVER C GOLD B & C PLATINUM B & C

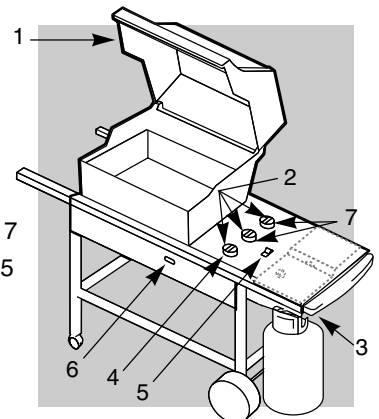

\*The grill illustrated may have slight differences than the model purchased.

## TO EXTINGUISH

Push down and turn each burner control knob clockwise to the OFF position. Turn gas supply OFF at the source.

## MANUAL LIGHTING

### ⚠ DANGER

Failure to open the lid while igniting the barbecue's burners, or not waiting 5 minutes to allow the gas to clear if the barbecue does not light, may result in an explosive flame-up which can cause serious bodily injury or death.

- 1) Open the lid.
- 2) Make sure all burner control knobs are turned OFF. (Push each knob down and turn clockwise to ensure they are in the off position.)

⚠ **WARNING:** The burner control knobs must be in the OFF position before turning on the liquid propane cylinder valve. If they are not in the OFF position, when you turn on the LP cylinder valve, the "excess gas flow control" feature will activate, limiting the flow of gas from the LP cylinder. If this should occur, turn OFF the LP tank valve and burner control knobs. Then start over.

### ⚠ DANGER

When the "excess gas flow control" feature is activated, a small amount of gas is still flowing to the burners. After turning OFF the cylinder and burner control knobs, wait at least 5 minutes for the gas to clear before attempting to light the barbecue. Failure to do so may result in an explosive flame-up, which can cause serious bodily injury or death.

- 3) Turn the cylinder on by turning the cylinder valve counterclockwise.
- 4) Strike a match and put the flame into the matchlight hole in the front of the cooking box.

⚠ **WARNING:** Do not lean over open barbecue. Keep your face and body at least one foot away from the matchlight hole when lighting the barbecue.

- 5) Push Front burner control knob down and turn to START/HI.
- 6) Check that the burner is lit by looking through the matchlight hole on the front of the cooking box. You should see a flame

⚠ **WARNING:** If the burner does not light, turn the Front burner control knob to OFF and wait 5 minutes to let the gas clear before you try again or try to light with a match.

- 7) After the FRONT burner is lit you can turn on the other burner.  
Note - Always light the FRONT burner first. The other burner or burners ignite from the FRONT burner.

## MAIN BURNER LIGHTING

### SILVER A & B

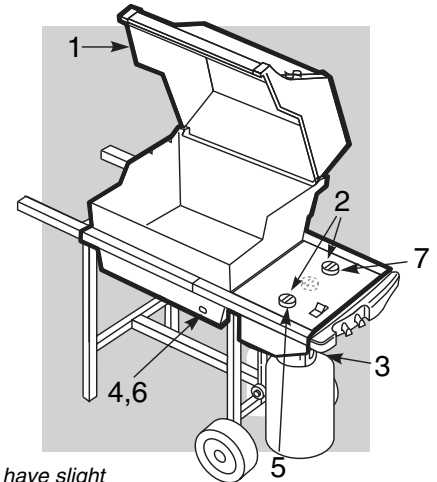

\*The grill illustrated may have slight differences than the model purchased.

## MAIN BURNER LIGHTING

### SILVER C GOLD B & C PLATINUM B & C

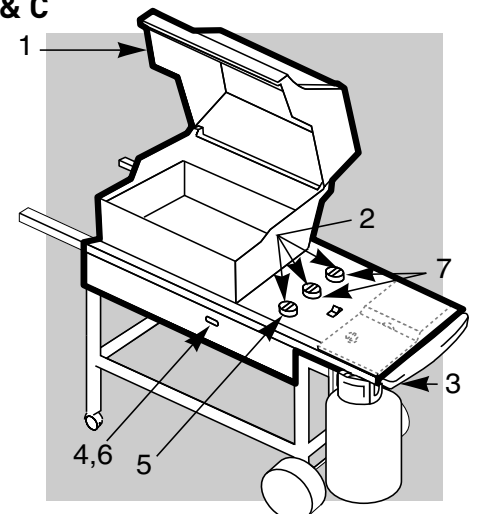

\*The grill illustrated may have slight differences than the model purchased.

## TO EXTINGUISH

Push down and turn each burner control knob clockwise to the OFF position. Turn gas supply OFF at the source.

# 14

# OPERATING INSTRUCTIONS

## LIGHTING THE SIDE BURNER

### ⚠ DANGER

Failure to open the lid while igniting the side burner, or not waiting 5 minutes to allow the gas to clear if the side burner does not light, may result in an explosive flame-up which can cause serious bodily injury or death.

#### Lighting only the side burner.

- 1) Open the side burner lid.
- 2) Check that the side burner valve is turned OFF. (Push each knob down and turn clockwise to ensure they are in the off position.), and all main burner control valves are OFF (push down and turn clockwise).
- 3) Turn the LP tank valve on (turn counter-clockwise).
- 4) Push down and turn the side burner control valve to HI.
- 5) Press the igniter button several times so it clicks each time.

⚠ **CAUTION: Side burner flame may be difficult to see on a bright sunny day.**

⚠ **WARNING: If the side burner does not light:**

- 1) Turn OFF the side burner control valve.
- 2) Wait 5 minutes to let the gas clear before you try again or try to light with a match.

#### Lighting the side burner if the main burners are lit.

- 1) Open the side burner lid.
- 2) Push down and turn the side burner control to HI.
- 3) Press the igniter button several times so it clicks each time.

⚠ **CAUTION: Side burner flame may be difficult to see on a bright sunny day.**

⚠ **WARNING: If the side burner does not light:**

- 1) Turn OFF the side burner control valve.
- 2) Wait 5 minutes to let the gas clear before you try again or try to light with a match.

## LIGHTING WITH IGNITER

### FOR SIDE BURNER MODELS

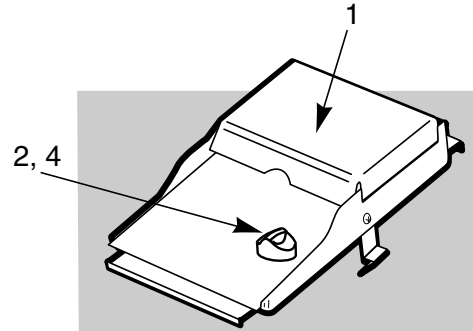

*\*The grill illustrated may have slight differences than the model purchased.*

## MANUAL LIGHTING

### FOR SIDE BURNER MODELS

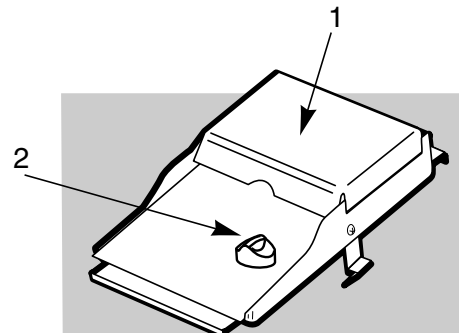

*\*The grill illustrated may have slight differences than the model purchased.*

PROBLEM	CHECK	CURE
<b>Burners burn with a yellow or orange flame, in conjunction with the smell of gas.</b>	Inspect Spider / Insect Screens for possible obstructions. (Blockage of holes.)	Clean Spider / Insect Screens. (See Section "Annual Maintenance")
<b>Burners do not light. -or- Burners have a small flickering flame in the HIGH position. -or- Barbecue temperature only reaches 250° to 300° in the HIGH position.</b>	The excess flow safety device, which is part of the barbecue to cylinder connection, may have activated.	To reset the excess flow safety device turn all burner control knobs and the cylinder valve OFF. Disconnect the regulator from the cylinder. Turn burner control knobs to HIGH. Wait at least 1 minute. Turn burner control knobs OFF. Reconnect the regulator to the cylinder. Turn cylinder valve on slowly. Refer to "Lighting Instructions".
<b>Burner does not light, or flame is low in HIGH position.</b>	Is LP fuel low or empty?	Refill LP cylinder.
	Is fuel hose bent or kinked?	Straighten fuel hose.
	Does the Left burner light with a match?	If you can light the Left burner with a match, then check the Crossover® ignition system.
<b>Experiencing flare-ups:</b>  ⚠ <b>CAUTION: Do not line the bottom tray with aluminum foil.</b>	Are you preheating barbecue in the prescribed manner?	All burners on high for 10 to 15 minutes for preheating.
	Are the cooking grates and Flavorizer® bars heavily coated with burned-on grease?	Clean thoroughly. (See Section "Cleaning")
	Is the bottom tray "dirty" and not allowing grease to flow into catch pan?	Clean bottom tray
<b>Burner flame pattern is erratic. Flame is low when burner is on HIGH. Flames do not run the whole length of the burner tube.</b>	Are burners clean?	Clean burners. (See Section "Maintenance".)
<b>Inside of lid appears to be "peeling." (Resembles paint peeling.)</b>	The lid is stainless steel, not paint. It cannot "peel". What you are seeing is baked on grease that has turned to carbon and is flaking off. <b>THIS IS NOT A DEFECT.</b>	Clean thoroughly. (See Section "Cleaning".)
<b>If problems cannot be corrected by using these methods, please contact the Customer Service Representative in your area using the contact information on our web site. Log onto <a href="http://www.weber.com">www.weber.com</a>®.</b>		

# 16

# SIDE BURNER TROUBLESHOOTING

PROBLEM	CHECK	CURE
Side Burner does not light.	Is gas supply off?  The excess flow safety device, which is part of the barbecue to cylinder connection, may have activated.	Turn supply on.  To reset the excess flow safety device turn all burner control knobs and the cylinder valve OFF. Disconnect the regulator from the cylinder. Turn burner control knobs to HIGH. Wait at least 1 minute. Turn burner control knobs OFF. Reconnect the regulator to the cylinder. Turn cylinder valve on slowly. Refer to "Lighting Instructions".
Flame is low in HIGH position	Is the fuel hose bent or kinked?	Straighten hose.
Push button ignition does not work.	Does burner light with a match?	If match lights burner, check igniter (see below).

If problems cannot be corrected by using these methods, please contact the Customer Service Representative in your area using the contact information on our web site. Log onto [www.weber.com](http://www.weber.com)®.

## SIDE BURNER MAINTENANCE

**⚠WARNING: All gas controls and supply valves should be in the OFF position.**

Make sure black wire is connected between the igniter and electrode  
**(1)**. Make sure white wire is connected between the igniter and grounding clip  
**(2)**. Spark should be a white/blue color, not yellow.

- 1) Igniter Wire
- 2) Ground wire
- 3) Burner

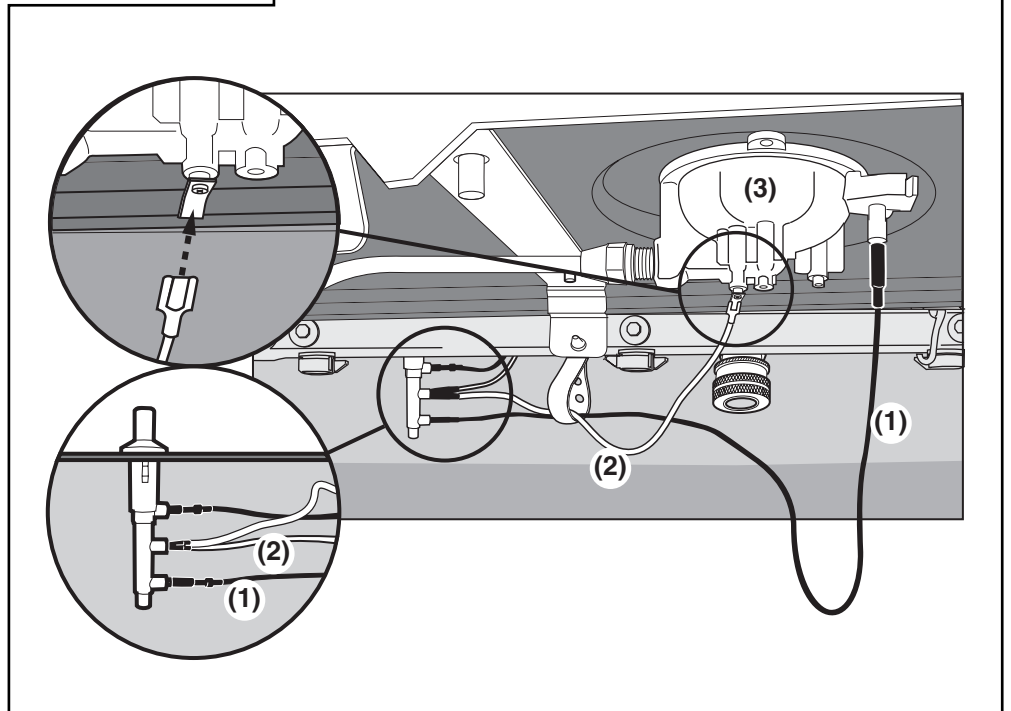
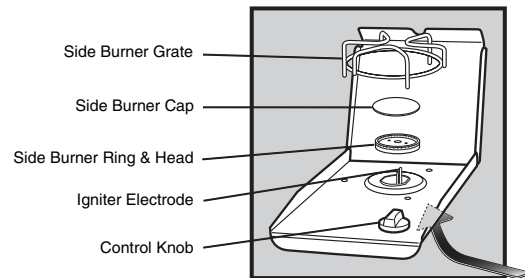

## WEBER® SPIDER /INSECT SCREENS

Your Weber® gas barbecue, as well as any outdoor gas appliance, is a target for spiders and other insects. They can nest in the venturi section(1) of the burner tubes. This blocks the normal gas flow, and can cause the gas to flow back out of the air shutter. This could result in a fire in and around the air shutters, under the control panel, causing serious damage to your barbecue. The burner tube air shutter is fitted with a stainless steel screen(1) to prevent spiders and other insects access to the burner tubes through the air shutter openings.

**We recommend that you inspect the Spider/Insect screens at least once a year. (See Section “Annual Maintenance”.) Also inspect and clean the the Spider/Insect screens if any of the following symptoms should ever occur:**

- 1) The smell of gas in conjunction with the burner flames appearing yellow and lazy.
- 2) Barbecue does not reach temperature.
- 3) Barbecue heats unevenly.
- 4) One or more of the burners do not ignite.

### ⚠DANGER

**Failure to correct the above mentioned symptoms may result in a fire, which can cause serious bodily injury or death, and cause damage to property.**

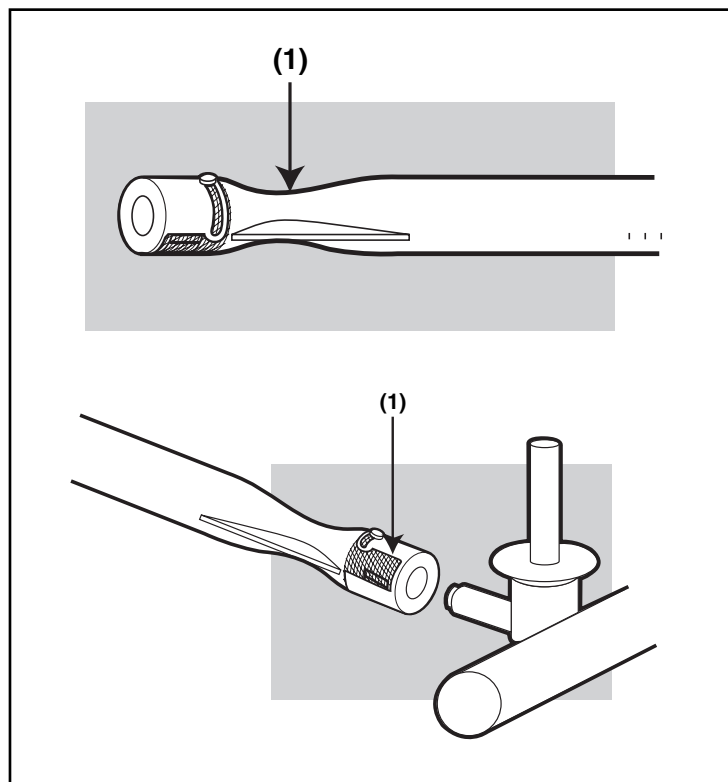

## ANNUAL MAINTENANCE

### Inspection and cleaning of the Spider/Insect screens

To inspect the spider/insect screens, remove the control panel. If there is dust or dirt on the screens, remove the burners for cleaning the screens.

Brush the spider/insect screens, lightly, with a soft bristle brush (i.e. an old toothbrush).

**⚠ CAUTION: Do not clean the spider/insect screens with hard or sharp tools. Do not dislodge the spider/insect screens or enlarge the screen openings.**

Lightly tap the burner to get debris and dirt out of the burner tube. Once the spider/insect screens and burners are clean replace the burners.

If the spider/insect screen becomes damaged or cannot be cleaned, call Weber-Stephen Products Customer Service for replacement parts.

**MAIN BURNER FLAME PATTERN**

The Weber® gas barbecue burners have been factory set for the correct air and gas mixture. The correct flame pattern is shown.

- 1) Burner tube
- 2) Tips occasionally flicker yellow
- 3) Light blue
- 4) Dark blue

If the flames do not appear to be uniform throughout the burner tube, follow the burner cleaning procedures.

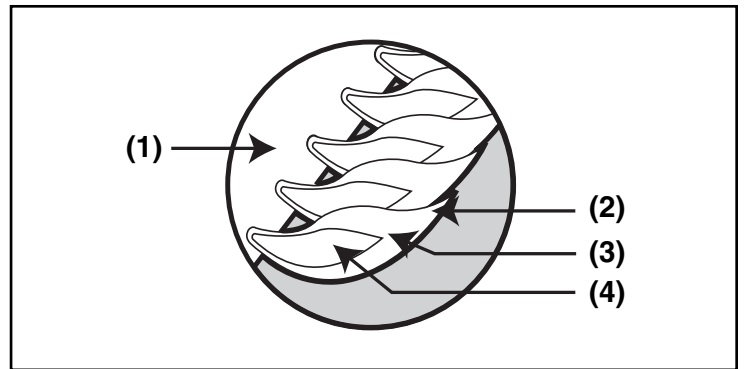
**MAIN BURNER CLEANING PROCEDURE****Turn off the gas supply.**

Remove the manifold.

Look inside each burner with a flashlight.

Clean the inside of the burners with a wire (a straightened-out coat hanger will work). Check and clean the air shutter opening at the ends of the burners. Check and clean the valve orifices at the base of the valves. Use a Steel bristle brush to clean outside of burners. This is to make sure all the burner ports are fully open.

**⚠ CAUTION: Do not enlarge the burner ports when cleaning.**

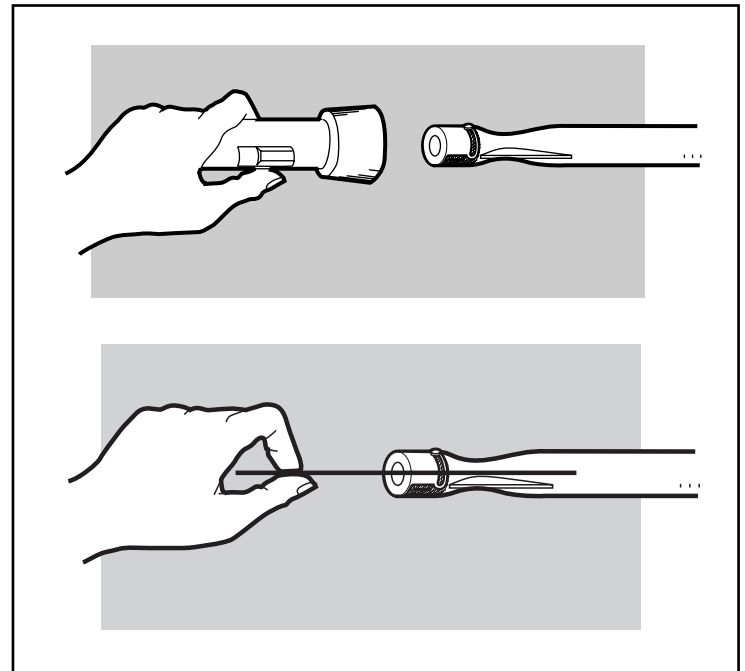
**REPLACING MAIN BURNERS**

- 1) Your Weber® gas barbecue must be OFF and cool.
- 2) Turn gas OFF at source.
- 3) To remove control panel: take off the burner control knobs. Remove the screws holding the control panel in place. Lift off the control panel.
- 4) Unhook the manifold bracket(1) and unscrew the two wing nuts(2) that hold the manifold to the cooking box. Pull the manifold and valve assembly out of the burners and carefully set it down.

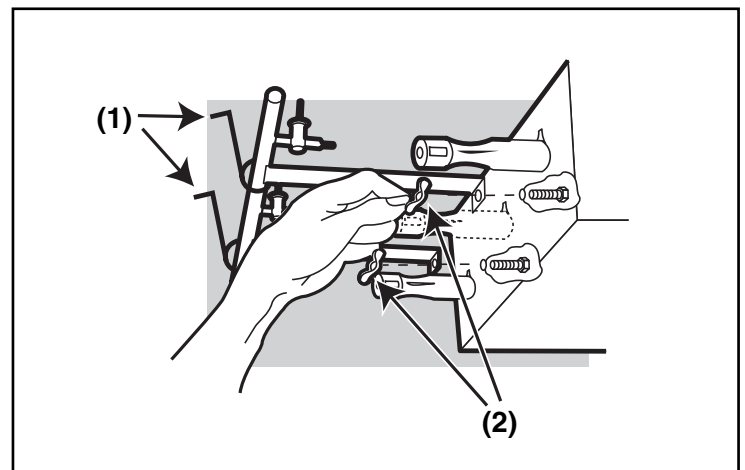

- 5) Slide the burner assembly out from under the guide screw and washer(1) in the corners of the cooking box.
- 6) Lift and twist the burner assembly slightly, to separate the crossover tube(1) from the burners. Remove the burners from the cooking box.
- 7) To reinstall the burners, reverse 3) through 7).

**⚠ CAUTION: The burner openings(1) must be positioned properly over the valve orifices(2).**

Check proper assembly before fastening manifold in place.

**⚠ WARNING: After reinstalling the gas lines, they should be leak checked with a soap and water solution before using the barbecue. (See Step: "Check for gas leaks.")**

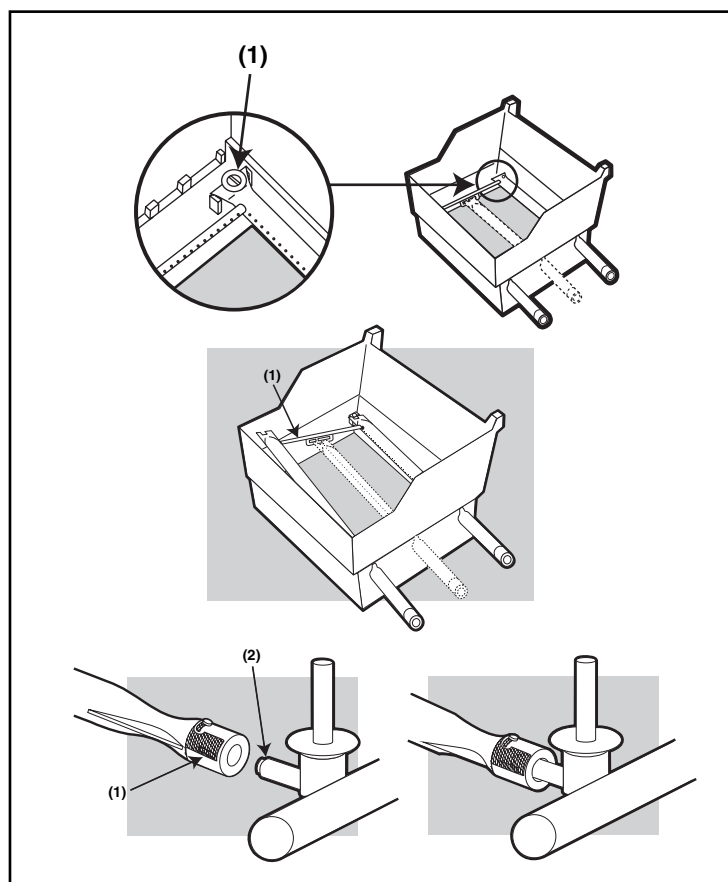

## CROSSOVER® IGNITION SYSTEM OPERATIONS

If the Crossover® ignition system fails to ignite the Left burner, light the Left burner with a match. If the Left burner lights with a match, then check the Crossover® ignition system.

- Check that both the white(1) and black(2) ignition wires are attached properly.
- Check that the Crossover® ignition button pushes the igniter (button) down, and returns to the up position.

**If the Crossover® ignition system still fails to light, contact the Customer Service Representative in your area using the contact information on our web site. Log onto [www.weber.com](http://www.weber.com)®.**

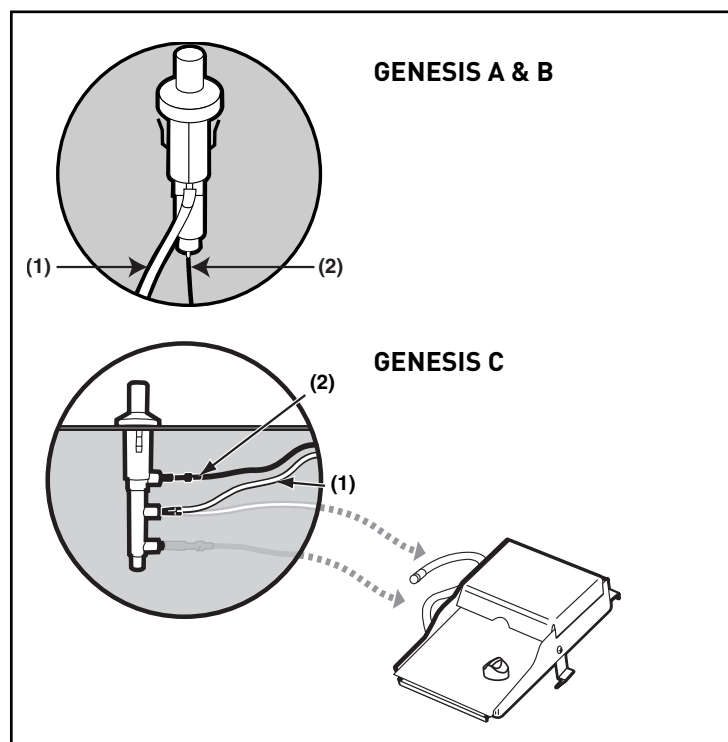



WEBER-STEPHEN PRODUCTS CO.  
[www.weber.com](http://www.weber.com)<sup>®</sup>

©2003 The following trademarks are registered in the name of Weber-Stephen Products Co., an Illinois corporation, located at 200 East Daniels Road, Palatine, Illinois 60067 U.S.A. Australia; Smokey Joe, Weber, Kettle Silhouette<sup>®</sup>, Genesis, Austria; Kettle Silhouette<sup>®</sup>, Smokey Joe, Weber, Benelux; Kettle Silhouette<sup>®</sup>, Smokey Joe, Weber, Compact Grill Configuration, Botswana; Weber, Canada; Smokey Joe, Genesis, China; Kettle Silhouette<sup>®</sup>, Denmark; Kettle Silhouette<sup>®</sup>, Smokey Joe, Weber, Finland; Smokey Joe, France; Kettle Silhouette<sup>®</sup>, Smokey Joe, Weber, One-Touch, Germany; Smokey Joe, Weber, One-Touch, Greece; Smokey Joe, Ireland; Kettle Silhouette<sup>®</sup>, Smokey Joe, Italy; Smokey Joe, Weber, Japan; Smokey Joe, Weber, Korea; Smokey Joe, Weber, New Zealand; Weber, Smokey Joe, Nigeria; Weber, Norway; Smokey Joe, Weber, Portugal; Weber, South Africa; Smokey Joe, Weber, Kettle Configuration, Spain; Smokey Joe, Weber, Sweden; Kettle Silhouette<sup>®</sup>, Smokey Joe, Switzerland; Kettle Silhouette<sup>®</sup>, Smokey Joe, Weber, United Kingdom; Smokey Joe, Weber, Weber One-Touch, U.S.A.; Kettle Configuration, Kettle Silhouette<sup>®</sup>, Smokey Joe, Weber, One-Touch, Firespice, Go-Anywhere, U.S.A.; Kettle Configuration, Kettle Silhouette, Genesis, Flavorizer, Crossover, Flamgo, Performer, Rapidfire, Tuck 'N Carry, Jumbo Joe, Bar-B-Kettle, Master-Touch, Spirit, Grill Out, Summit, Platinum, 1-800-Grill-Out, Ranch, Matchless Flame, Zimbabwe; Weber, Kettle Configuration, Kettle Silhouette<sup>®</sup>.