



# PLATINUM™ SERIES II LP Gas Barbecues

## Operating Guide

**Read before assembly**



Platinum Series II  
2200 LP

Serial Number

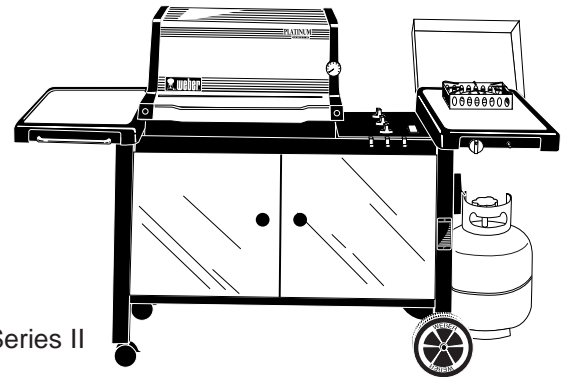

Platinum Series II  
3400 LP

Serial Number

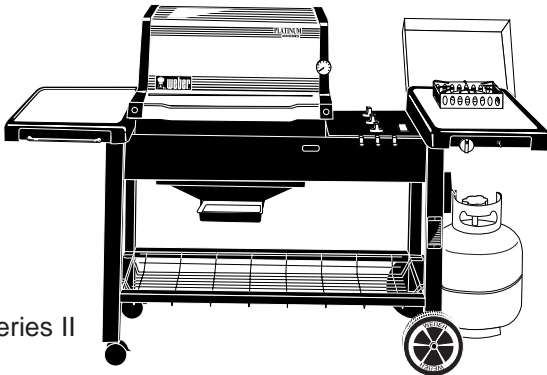

Platinum Series II  
3200 LP

Serial Number



**WARNING: Do not operate this barbecue without reading the entire operating guide.**

**THIS GAS APPLIANCE IS DESIGNED FOR OUTDOOR USE ONLY.**

**WARNING: Follow all leak check procedures carefully in this manual prior to barbecue operation. Do this even if barbecue was dealer assembled.**

**NOTICE TO INSTALLER: These instructions must be left with the owner and the owner should keep them for future use.**

### FOR YOUR SAFETY

Do not store or use gasoline or other flammable vapors and liquids in the vicinity of this or any other appliance.

### FOR YOUR SAFETY

If you smell gas:

1. Shut off gas to the appliance.
2. Extinguish any open flame.
3. Open lid.
4. If odor continues, immediately call your gas supplier or your fire department.

# TABLE OF CONTENTS

<b>Warnings</b>	<b>3</b>	<b>Maintenance</b>	<b>11-13</b>
<b>Warranty</b>	<b>4</b>	Spider Stopper Guards	11
<b>A Word of Thanks</b>	<b>4</b>	Inspection and Cleaning of the Spider Stopper Guards	11
<b>Standards and Codes Information</b>	<b>5</b>	Main Burner Flame Pattern	12
Operation	5	Main Burner Cleaning Procedure	12
Storage	5	Replacing the Main Burners	12
<b>*REFER TO YOUR STEP-BY-STEP SECTION AT THIS TIME</b>		Crossover Ignition System Operations	13
<b>Lighting</b>	<b>6</b>	<b>Troubleshooting</b>	<b>14</b>
Crossover Ignition System	6	<b>Side Burner Troubleshooting</b>	<b>15</b>
To Extinguish	6	<b>Side Burner Maintenance</b>	<b>16-17</b>
<b>Manual Lighting</b>	<b>7</b>	To Clean the Burner Head	17
To Extinguish	7	To reassemble the Burner Head	17
<b>Lighting the Side Burner</b>	<b>8</b>	<b>Side Burner Exploded View</b>	<b>17</b>
<b>Cooking</b>	<b>9</b>	<b>Exploded Views and Replacement Parts List</b>	<b>18-23</b>
<b>Cleaning</b>	<b>9</b>	Platinum Series II 2200 LP	18-19
<b>Using the Steam-N-Chips Smoker</b>	<b>10</b>	Platinum Series II 3200 LP	20-21
Cleaning the Steam-N-Chips Smoker	10	Platinum Series II 3400 LP	22-23
		<b>Patents and Trademarks</b>	<b>24</b>

# WARNINGS

## **⚠ DANGER**

**Failure to follow the Dangers, Warnings and Cautions contained in this Owner's Manual may result in serious bodily injury or death, or in a fire or an explosion causing damage to property.**

- Do not store a spare or disconnected LP tank under or near this barbecue.
- Improper assembly may be dangerous. Please carefully follow the assembly instructions in this manual.
- After a period of storage, and/or nonuse, the Weber Gas Barbecue should be checked for gas leaks and burner obstructions before using. See instructions in this manual for correct procedures.
- Do not operate the Weber Gas Barbecue if there is a gas leak present.
- Do not use a flame to check for gas leaks.
- Combustible materials should never be within 24 inches of the top, bottom, back or sides of your Weber Gas Barbecue.
- Do not put a barbecue cover or anything flammable on or in the storage area under the barbecue.
- Your Weber Gas Barbecue should never be used by children.
- You should exercise reasonable care when operating your Weber Gas Barbecue. It will be hot during cooking or cleaning, and should never be left unattended.
- Should the burners go out during operation, turn all gas valves off. Open the lid and wait five minutes before attempting to relight, using the lighting instructions.
- Do not use charcoal or lava rock in your Weber Gas Barbecue.
- Never lean over open grill or place hands or fingers on the front edge of the cooking box.
- Should a grease fire occur, turn off all burners and leave lid closed until fire is out.
- Do not enlarge valve orifices or burner ports when cleaning the valves or burners.
- The Weber Gas Barbecue should be thoroughly cleaned on a regular basis.
- LP gas is not natural gas. The conversion or attempted use of natural gas in an LP unit or LP gas in a natural gas unit is dangerous and will void your warranty.
- Do not attempt to disconnect any gas fitting while your barbecue is in operation.
- Use heat-resistant barbecue mitts or gloves when operating barbecue.
- This barbecue is for residential use only.

### **LP GAS UNITS ONLY:**

- Use the regulator that is supplied with your Weber Gas Barbecue.
- Do not attempt to disconnect the gas regulator or any gas fitting while your barbecue is in operation.
- A dented or rusty LP tank may be hazardous and should be checked by your liquid propane supplier. Do not use an LP tank with a damaged valve.
- Although your LP tank may appear to be empty, gas may still be present, and the tank should be transported and stored accordingly.
- If you see, smell or hear the hiss of escaping gas from the LP tank:
  1. Get away from LP tank.
  2. Do not attempt to correct the problem yourself.
  3. Call your fire department.

# WARRANTY

Weber-Stephen Products Co. (Weber) hereby warrants to the ORIGINAL PURCHASER of this Weber Gas Barbecue that it will be free of defects in material and workmanship from the date of purchase as follows:

- Aluminum Castings, 10 years,
- Cooking Grates, 3 years
- Flavorizer Bars, 5 years,
- All Remaining Parts, 5 years,

when assembled and operated in accordance with the printed instructions accompanying it.

Weber may require reasonable proof of your date of purchase. THEREFORE, YOU SHOULD RETAIN YOUR SALES SLIP OR INVOICE.

This Limited Warranty shall be limited to the repair or replacement of parts which prove defective under normal use and service and which on examination shall indicate, to Weber's satisfaction, they are defective. Before returning any parts, contact Weber-Stephen Products Co. Customer Service Center. If Weber confirms the defect and approves the claim, Weber will elect to replace such parts without charge. If you are required to return defective parts, transportation charges must be prepaid. Weber will return parts to the purchaser, freight or postage prepaid.

This Limited Warranty does not cover any failures or operating difficulties due to accident, abuse, misuse, alteration, misapplication, vandalism, improper installation or improper maintenance or service, or failure to perform normal and routine maintenance, including but not limited to damage caused by insects within the burner tubes, as set out in this owner's manual.

Deterioration or damage due to severe weather conditions such as hail, hurricanes, earthquakes or tornadoes, acid rain, discoloration due to exposure to chemicals either directly or in the atmosphere, is not covered by this Limited Warranty.

There are no other express warrants except as set forth herein and any applicable implied warranties of merchantability and fitness are limited in duration to the period of coverage of this express written Limited Warranty. Some states do not allow limitation on how long an implied warranty lasts, so this limitation may not apply to you.

Weber is not liable for any special, indirect or consequential damages. Some states do not allow the exclusion or limitation of incidental or consequential damages, so this limitation or exclusion may not apply to you.

Weber does not authorize any person or company to assume for it any other obligation or liability in connection with the sale, installation, use, removal, return, or replacement of its equipment; and no such representations are binding on Weber.

This Warranty applies only to products sold at retail.

## A WORD OF THANKS

*Thank you for choosing a Weber Barbecue. Our family here at Weber has worked hard to produce the highest quality products for your satisfaction. While we give much attention to our products, an occasional error may occur. Our knowledgeable Customer Service staff is prepared to help you with any problems with parts or assembly. Call our toll free number. For quicker service, please have your owner's manual and serial number available for reference. We also welcome any comments or suggestions you might have regarding our products. We wish you the best in outdoor cooking enjoyment.*

*Weber-Stephen Products Company  
Customer Service Center  
250 South Hicks Road  
Palatine, IL 60067-6266  
(800) 446-1071*

# STANDARDS AND CODES INFORMATION

Your Weber Gas Barbecue is a portable outdoor cooking appliance. With the Weber Gas Barbecue you can grill, barbecue, roast and bake with results that are difficult to duplicate with indoor kitchen appliances. The closed lid and Flavorizer Bars produce that "outdoor" flavor in the food.

The Weber Gas Barbecue is portable so you can easily change its location in your yard or on your patio. Portability means you can take your Weber Gas Barbecue with you if you move.

Liquid Propane (LP) gas supply is easy to use and gives you more cooking control than charcoal fuel.

- These instructions will give you the minimum requirements for operating and maintaining your Weber Gas Barbecue. Please read the instructions carefully before using your Weber Gas Barbecue. Improper assembly can be dangerous.
- Not for use by children.
- If there are local codes that apply to portable gas grills, you will have to conform to them. If there are no local codes, you must conform to the latest edition of the National Fuel Gas Code: ANSI Z 223.1.
- The pressure regulator supplied with the Weber Gas Barbecue must be used. This regulator is set for 10.5 inches of water column (pressure).
- This Weber Gas Barbecue is designed for use with liquid propane (LP) gas only. Do not use with natural (piped in city) gas. The valves, orifices, hose and regulator are for LP gas only.
- Do not use with charcoal fuel.
- The Weber Gas Barbecue should be checked for gas leaks and any obstructions in the burner tubes before using. (See Maintenance Section.)
- Check that the areas under the control panel and the bottom tray are free from debris that might obstruct the flow of combustion or ventilation air. (See Maintenance Section.)

## For Installation in Canada

These instructions, while generally acceptable, do not necessarily comply with the Canadian Installation codes, particularly with piping above and below ground. In Canada the installation of this appliance must comply with local codes and/or Standard CAN/CGA-B149.2 (Installation Code for Propane Burning Appliances and Equipment).

## Storage

- The gas must be turned OFF at the LP tank when the Weber Gas Barbecue is not in use.
- When the Weber Gas Barbecue is stored indoors, the gas supply must be disconnected and the LP tank stored outdoors in a well-ventilated space.
- LP tanks must be stored outdoors in a well-ventilated area out of the reach of children. Disconnected LP tanks must have threaded valve plugs tightly installed and must not be stored in a building, garage or any other enclosed area.
- When the LP tank is not disconnected from the Weber Gas Barbecue, the appliance and LP tank must be kept outdoors in a well-ventilated space.

## Operating area

**⚠WARNING: Only use this barbecue outdoors in a well ventilated area. Do not use in a garage, building, breezeway or any other enclosed area.**

- Never use your Weber Gas Barbecue under an unprotected combustible roof or overhang.
- Your Weber Gas Barbecue is not intended to be installed in or on recreational vehicles and/or boats.
- Keep this grill away from combustible materials when in use at a minimum of 24 inches of the top, bottom, back or sides.
- The entire cooking box gets hot when in use. Do not leave unattended.
- Keep any electrical supply cord and the fuel supply hose away from any heated surface.
- Keep the cooking area clear of flammable vapors and liquids, such as gasoline, alcohol, etc., and combustible materials.
- Never store an extra (spare) LP tank under or near the Weber Gas Barbecue.

## REFER TO YOUR STEP-BY-STEP SECTION AT THIS TIME FOR BARBECUE ASSEMBLY

**⚠WARNING: Make sure your barbecue is set up properly and leak checked before attempting to operate.**

# LIGHTING THE MAIN BURNERS

Summary lighting instructions are on the control panel.

## **⚠DANGER**

Failure to open lid while igniting the barbecue, or not waiting 5 minutes to allow the gas to clear if the barbecue does not light, may result in an explosive flame-up which can cause serious bodily injury or death.

### Crossover Ignition System

*Note - The Crossover Ignition System ignites the Front burner with a spark from the igniter electrode inside the Gas Catcher Ignition Chamber. You generate the energy for the spark by pushing the Crossover Ignition Button until it clicks.*

**⚠WARNING:** Check hose before each use of barbecue for nicks, cracking, abrasions or cuts. If the hose is found to be damaged in any way, do not use the barbecue. Replace using only Weber authorized replacement manifold assembly. Order from Weber-Stephen Products Co., Customer Service Center or authorized dealer.

Crossover Ignition System

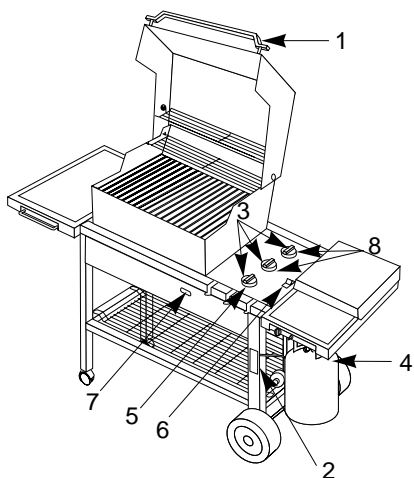

Figure 1

- 1) Open the lid. Figure 1.
- 2) Check that the fuel scale reads more than "E".  
*Note - E = empty; F = full.*
- 3) Make sure all burner control knobs are OFF. (Push each burner control knob down and turn clockwise.)

*For barbecues equipped with a side burner, push the burner control knob in and turn clockwise to OFF.*

**⚠WARNING:** The burner control knobs must be in the OFF position before turning on the LP tank valve. If they are not in the OFF position, when you turn on the LP tank valve, the excess flow control will activate, limiting the flow of gas from the LP tank. If this should occur, turn OFF the LP tank valve and burner control knobs and start over.

## **⚠DANGER**

When the excess flow control is activated, a small amount of gas is still flowing to the burners. After turning OFF the tank and burner control knobs, wait at least 5 minutes for the gas to clear before attempting to light the barbecue. Failure to do so may result in an explosive flame-up which can cause serious bodily injury or death.

- 4) Turn the tank on by turning the tank valve counterclockwise slowly, and open the valve completely.

**⚠WARNING:** Do not lean over open barbecue. Keep your face and body at least one foot away from the matchlight hole when lighting the barbecue.

- 5) Push Front burner control knob down and turn to START/HI.
- 6) Push the Crossover Ignition Button several times, so it clicks each time.
- 7) Check that the burner is lit through the matchlight hole on the front of the cooking box. **(For closed cart models, open the right door to access the matchlight hole.)**

**⚠WARNING:** If the burner does not light, turn the Front burner control knob to OFF and wait 5 minutes to let the gas clear before you try again or try to light with a match.

- 8) After the FRONT burner is lit you can turn on the other burners.

*Note - Always light the FRONT burner first. The other burners ignite from the FRONT burner.*

## TO EXTINGUISH

Turn gas supply OFF at the source, then push down and turn each burner control knob clockwise to OFF.

# MANUAL LIGHTING THE MAIN BURNERS

## ⚠DANGER

Failure to open lid while igniting the barbecue, or not waiting 5 minutes to allow the gas to clear if the barbecue does not light, may result in an explosive flame-up which can cause serious bodily injury or death.

- 1) Open the lid. Figure 2.
- 2) Check that fuel scale reads more than "E".  
Note - E = empty; F = full.
- 3) Make sure all burner control knobs are OFF. (Push each burner control knob down and turn clockwise.)

*For barbecues equipped with a side burner, push the burner control knob in and turn clockwise to OFF.*

**⚠WARNING:** The burner control knobs must be in the OFF position before turning on the LP tank valve. If they are not in the OFF position, when you turn on the LP tank valve, the excess flow control will activate, limiting the flow of gas from the LP tank. If this should occur, turn OFF the LP tank valve and burner control knobs and start over.

## ⚠DANGER

When the excess flow control is activated, a small amount of gas is still flowing to the burners. After turning OFF the tank and burner control knobs, wait at least 5 minutes for the gas to clear before attempting to light the barbecue. Failure to do so may result in an explosive flame-up which can cause serious bodily injury or death.

- 4) Turn the tank on by turning the tank valve counterclockwise slowly, and open the valve completely.
- 5) Strike a match and put the flame into the matchlight hole in the front of the cooking box. **(For closed cart models, open the right door to access the matchlight hole.)**

**⚠WARNING:** Do not lean over open barbecue. Keep your face and body at least one foot away from the matchlight hole when lighting the barbecue.

- 6) Push Front burner control knob down and turn to START/Hi.
- 7) Check that the burner is lit by looking through the matchlight hole on the front of the cooking box. **(For closed cart models, open the right door to access the matchlight hole.)**

**⚠WARNING:** If the burner does not light, turn the Front burner control knob to OFF and wait 5 minutes to let the gas clear before you try again or try to light with a match.

- 8) After the FRONT burner is lit you can turn on the other burners.

*Note - Always light the FRONT burner first. The other burners ignite from the FRONT burner.*

## TO EXTINGUISH

Turn gas supply OFF at the source, then push down and turn each burner control knob clockwise to OFF.

Manual Lighting

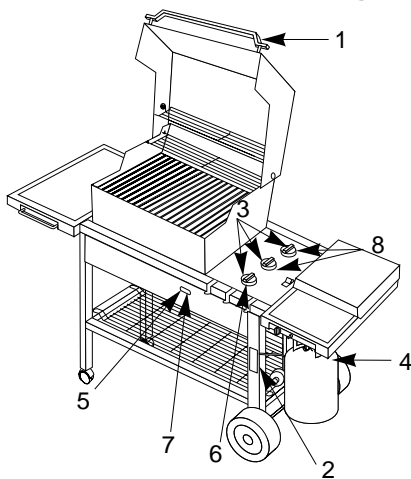

Figure 2



# LIGHTING THE SIDE BURNER

For the Platinum Series II 3200 & 3400

The side burner has a separate ignition system from the main cooking box.

## **⚠DANGER**

**Failure to open lid while igniting the side burner, or not waiting 5 minutes to allow gas to clear if the side burner does not light, may result in an explosive flame-up which can cause serious bodily injury or death.**

**⚠CAUTION:** Side burner flame may be difficult to see on a bright sunny day.

**⚠WARNING:** If the side burner does not light:

- a) Turn off the side burner control valve.
- b) Wait 5 minutes to let the gas clear before you try again or try to light with a match.

**⚠WARNING:** The container and contents used on the side burner should not exceed a maximum of 50 pounds. The container should not exceed 14 inches in diameter.

**Lighting only the side burner. Figure 3.**

- 1) Open the side burner cover.
- 2) Check that the fuel scale reads more than "E".
- 3) Check that the side burner valve is OFF (push in and turn clockwise), and all main burner control valves are OFF (push down and turn clockwise).
- 4) Turn the LP tank valve on (turn counterclockwise).
- 5) Push in and turn the side burner control knob to HI.
- 6) Push the side burner igniter button several times so it clicks each time.

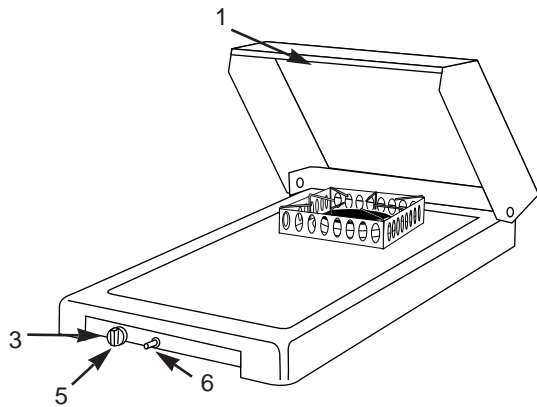

**Figure 3**



## COOKING

The Weber Gas Barbecue should not be moved when operating or hot.

*Note: The temperatures inside your cooking box, for the first few uses, while surfaces are still very reflective, may be hotter than those shown in your cookbook. Cooking conditions may require the adjustment of the burner controls to attain the correct cooking temperatures.*

**⚠CAUTION: Replace thermometer in lid when not in use. Do not leave thermometer in food while cooking. If burners go out during cooking, open lid, turn off all burners and wait 5 minutes before relighting.**

**⚠CAUTION: Check the bottom tray for grease build-up before each use. Remove excess grease to avoid a grease fire in the bottom tray.**

Refer to your cookbook for detailed charts, cooking instructions and recipes. If you did not receive your cookbook, please call our Customer Service Center toll free at (800) 446-1071.

## CLEANING

**⚠CAUTION: Turn your Weber Gas Barbecue OFF and wait for it to cool before cleaning.**

**⚠CAUTION: Do not clean your Flavorizer Bars or cooking grates in a self-cleaning oven. Replacement cooking grates and Flavorizer Bars are available through your retailer or the Weber-Stephen Customer Service Center.**

**Outside surfaces** - Use a warm soapy water solution.

**⚠CAUTION: Do not use oven cleaner, abrasive cleansers (kitchen cleansers) cleaners that contain citrus products or abrasive cleaning pads on barbecue or cart surfaces.**

**Bottom tray** - Remove excess grease and then wash with warm soapy water.

**⚠WARNING: Use heat-resistant barbecue mitts or gloves when cleaning the cooking grates and Flavorizer bars.**

**Flavorizer Bars and Cooking Grates**- Clean with a suitable brass bristle brush. As needed, remove from grill and wash with warm soapy water.

**Flavorizer Bars and Cooking Grates (alternate method)** - After pre-heating the grill, prior to cooking, brush the cooking grates with a brass wire brush or crumpled aluminum foil.

After cooking, turn all main burners on HIGH and let grill heat for 10 minutes, Brush cooking grates and Flavorizer bars with a brass wire brush.

**Catch pan** - Disposable foil trays are available, or you can line the catch pan with aluminum foil. To clean the catch pan, wash with warm soapy water.

**Thermometer** - Wipe with warm soapy water, clean with plastic scrub ball. Do not put in dishwasher or submerge in water.

**Inside cooking box** - Brush any debris off of burners tubes. **DO NOT ENLARGE BURNER PORTS (OPENINGS).** Wash inside of cooking box with warm soapy water.

**Inside Lid** - While lid is warm, wipe inside with paper towel to prevent flaking due to grease build-up.

**Stainless steel surfaces** - Wash with soap and water and a soft cloth.

# USING THE STEAM-N-CHIP SMOKER

The Steam-N-Chips Smoker cooks with both Weber FireSpice Wood Chips and Chunks. For best results with faster cooking foods like steaks, burgers and chops, etc., we recommend using the FireSpice Chips because they ignite and create smoke faster. For longer cooking foods such as roasts, chicken and turkeys, etc., we recommend using FireSpice Chunks because they ignite slowly and provide smoke for a longer period of time. As you gain experience in using your Steam-N-Chips Smoker, we encourage you to experiment with different combinations of FireSpice Chips and Chunks to find the smoke flavor that best suits your taste.

## To use the Steam-N-Chips Smoker

As a starting point, place a handful of FireSpice Chips or a few FireSpice Chunks in the bottom of the smoker body. Figure 4. Since the chunks vary in size, place as many as you can in the smoker allowing room for the water pan. As you gain experience in smoking, increase or decrease the amount of wood to suit your taste. Fill water pan, place it in the smoker and close the smoker lid.

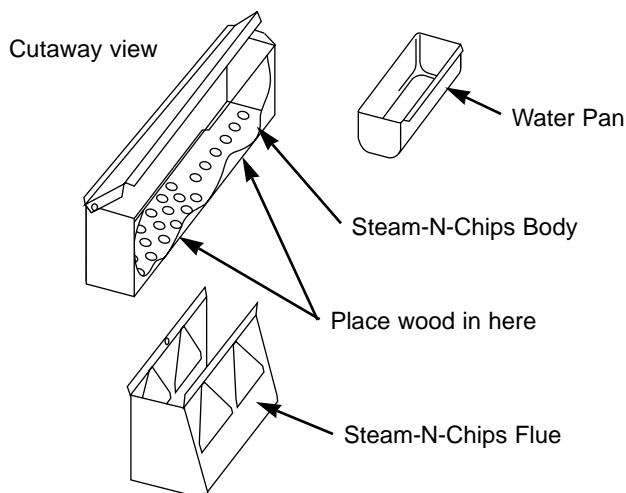

**Figure 4**

Light the barbecue and preheat with all burners on HIGH, lid down, for 10 minutes or until the thermometer registers 500°F - 550°F. Adjust the burners for cooking; MOM or LOL will be your best settings for long duration smoking. Smoke will start in approximately 10 minutes and last as long as 45 minutes. If you require more smoke flavor, refill the smoker with FireSpice Chips and/or Chunks and refill the water pan with water. The Steam-N-Chips Smoker may be used to enhance any of the meat, poultry and fish recipes in the gas barbecue cookbook. Cook with the lid down according to the times indicated in charts or recipes.

*Note - After refilling smoker, smoke will take about 10 to 15 minutes to start again.*

## **⚠ DANGER**

**Do not use any flammable fluid in the Steam-N-Chips Smoker to ignite the wood. This will cause serious bodily injury.**

## Cleaning the Steam-N-Chips Smoker

Before each use, empty the Steam-N-Chips Smoker of ash to allow proper air flow. Accomplish this by lightly tapping the sides of the smoker and stirring the ashes so that they sift through the bottom and fall into the bottom tray of your barbecue. Remove bottom tray and empty.

*Note - Smoking will leave a "smoke" residue on the surface of the smoker. This residue cannot be removed and will not affect the function of the Steam-N-Chips Smoker. To a lesser degree a "smoke" residue will accumulate on the inside of your Weber Gas Barbecue. This residue need not be removed and will not adversely affect the function of your Weber Gas Barbecue.*

# MAINTENANCE

## Spider Stopper Guards

Your Gas Barbecue, as well as any outdoor gas appliance, is a target for spiders and other insects. They can nest in the venturi section of the burner tubes. This blocks the normal gas flow, and can cause the gas to flow back out of the air shutter. Figure 5. This could result in a fire in and around the air shutters, under the control panel, causing serious damage to your barbecue.

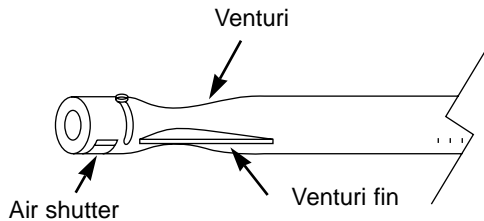

Figure 5

The Spider Stopper Guard is factory installed. It fits tightly around the air shutter section of the burner tube and the valve, thereby preventing spiders and other insects access to the burner tubes through the air shutter openings. Figure 6.

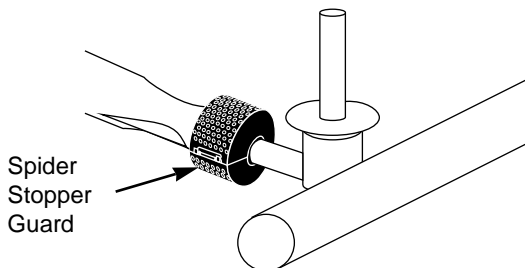

Figure 6

**We recommend that you inspect the Spider Stopper Guards at least once a year. Also inspect and clean the Spider Stopper Guards if any of the following symptoms should ever occur.**

1. The smell of gas in conjunction with the burner flames appearing yellow and lazy.
2. Barbecue does not reach temperature.
3. Barbecue heats unevenly.
4. One or more of the burners do not ignite.

## **⚠ DANGER**

**Failure to correct these symptoms may result in a fire which can cause serious bodily injury or death and cause damage to property.**

## Inspection and Cleaning of the Spider Stopper Guards

To inspect the Spider Stopper Guards, remove the control panel and look to see if they have dust or dirt on their outside surfaces. If they are dirty, brush off the outside surface of the Spider Stopper Guards with a soft bristle brush (an old toothbrush for example). Check that there are no gaps in the Spider Stopper Guards' seams or in the fit around the burners or valves.

# MAINTENANCE

## Main Burner Flame Pattern

The Weber Gas Barbecue burners have been factory set for the correct air and gas mixture. The correct flame pattern is shown in Figure 7.

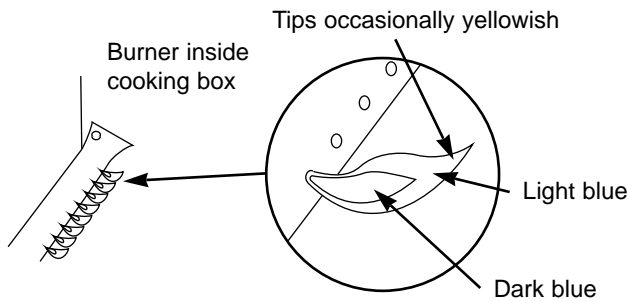

Figure 7

If the flames do not appear to be uniform the length of the burner tube, follow the burner cleaning procedures.

## Main Burner Cleaning Procedure

**Turn off the gas supply.** Remove the manifold.

Look inside each burner with a flashlight. Figure 8.

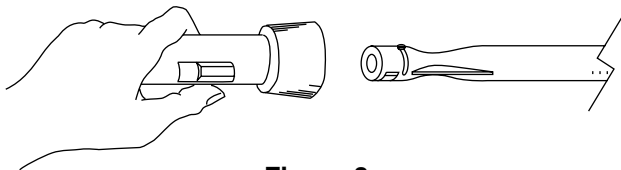

Figure 8

Clean the inside of the burners with a wire (a straightened out coat hanger will work). Figure 9. Check and clean the air shutter opening at the ends of the burners. Check and clean the valve orifices at the base of the valves. Use a brass bristle brush to clean outside of burners. This is to make sure all the burner ports are fully open.

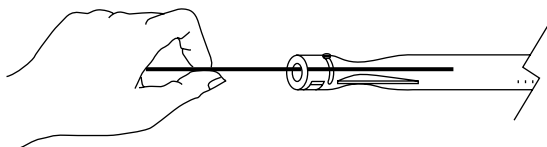

Figure 9

**⚠CAUTION:** Do not enlarge the burner ports when cleaning.

## Replacing Main Burners

- Your Weber Gas Barbecue must be OFF and cool.
- Turn gas OFF at source.
- To remove control panel, see the Step-By-Step Guide.
- Unlatch the Spider Stopper Guards and remove. Figure 10.

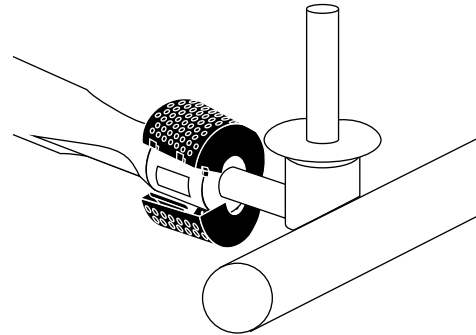

Figure 10

- If your barbecue has a side burner, disconnect the side burner hose.
- Remove the manifold bracket and unscrew the two wing nuts that hold the manifold to the cooking box. Pull the manifold and valve assembly out of the burners and carefully set it down. Figure 11.

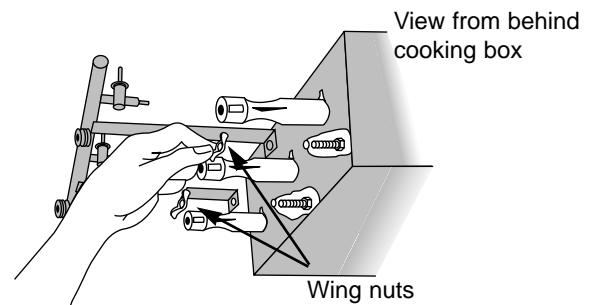

Figure 11

- Slide the burner assembly out from under the guide screw and washer in the corners of the cooking box. Figure 12.

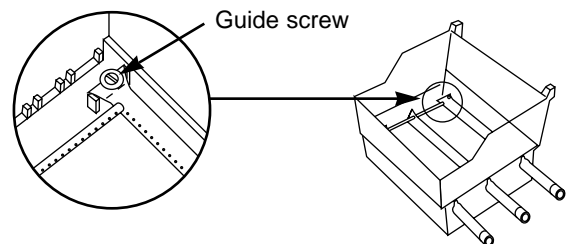

Figure 12

# MAINTENANCE

- h) Lift and twist the burner assembly slightly, to separate the crossover tube from the burners. Figure 13. Remove the burners from the cooking box.

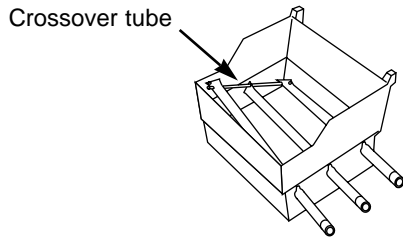

Figure 13

- i) To reinstall the burners, reverse steps c) through h).

**⚠CAUTION: The burner openings must be positioned properly over the valve orifices. Figure 14 (a).**

Check proper assembly before fastening manifold in place. Figure 14 (b).

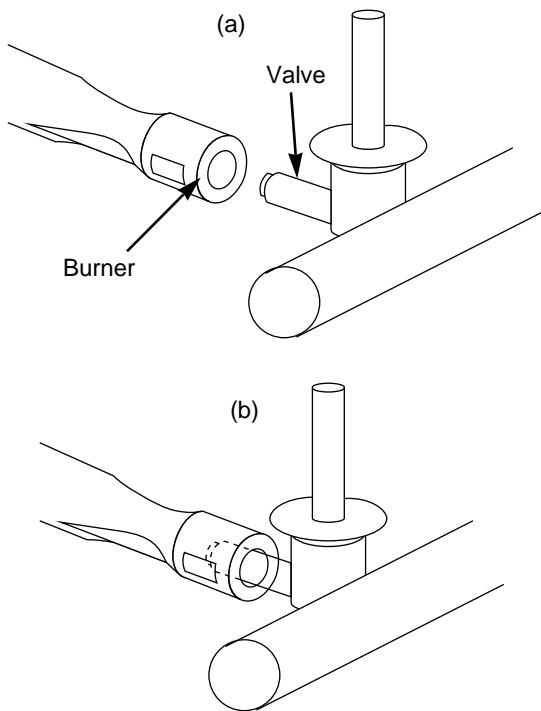

Figure 14

- j) Reinstall the Spider Stopper Guards. Slightly rotate the Spider Stopper Guards so that the seams are in line with the Venturi fins. There should be no gaps in the seams or in the fit around the burners and valves. Figure 15.

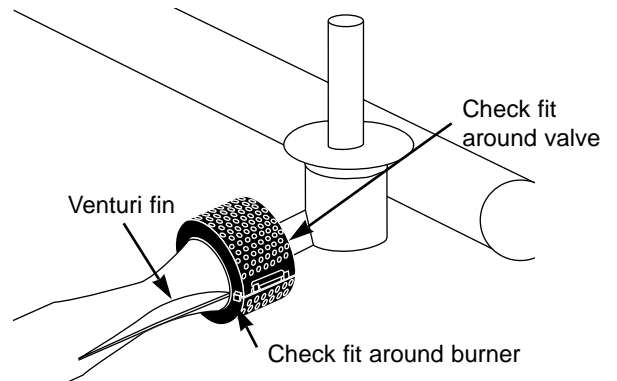

Figure 15

**⚠CAUTION: If the Spider Stopper Guards do not fit tightly, contact Weber-Stephen Customer Service.**

**⚠CAUTION: After reinstalling the gas lines, they should be leak checked with a soap and water solution before using the barbecue.**

## Crossover Ignition System Operations

If the Crossover Ignition System fails to ignite the Front burner, light the Front burner with a match. If the Front burner lights with a match, then check the Crossover Ignition System.

- Check that both the white and black ignition wires are attached properly. Figure 16.
- Check that the Crossover Ignition button pushes the igniter (button) down, and returns to the up position.
- Check to see if the igniter is loose in the frame. Tighten if necessary; See "Check That Items Are Secured" in the Step-By-Step Guide for correct procedure.

If the Crossover Ignition System still fails to light, contact Weber-Stephen Customer Service.

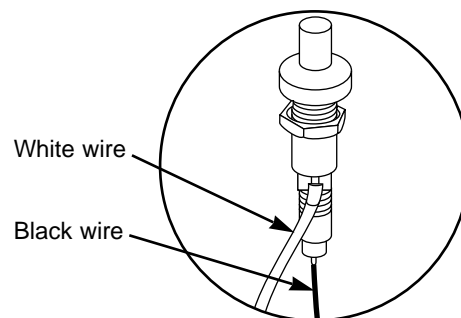

Figure 16

# TROUBLESHOOTING

Problem	Check	Cure
Burners burn with a yellow or orange flame, in conjunction with the smell of gas.	Inspect Spider Stopper Guards for possible obstructions. (Blockage of holes.)	Clean Spider Stopper Guards. (See Maintenance Section.)
Burners do not light. -or- Burners have a small flickering flame in the HIGH position. -or- Barbecue temperature only reaches 250° to 300° degrees in the HIGH position.	The excess flow safety device, which is part of the barbecue to tank connection, may have activated.	To reset the excess flow safety device turn all burner control knobs and the tank valve OFF. Disconnect the regulator from the tank. Turn burner control knobs to HIGH. Wait at least 1 minute. Turn burner control knobs OFF. Reconnect the regulator to the tank. Turn tank valve on slowly. Refer to Lighting Section.
Burner does not light, or flame is low in HIGH position.	Is LP fuel low or empty?	Refill LP tank.
	Is fuel hose bent or kinked?	Straighten fuel hose.
	Does the Front burner light with a match?	If you can light the Front burner with a match, then check the Crossover Ignition System.
Experiencing flare-ups:	Are you preheating barbecue in the prescribed manner?	All burners on high for 10 to 15 minutes for preheating.
	Are the cooking grates and Flavorizer Bars heavily coated with burned-on grease?	Clean thoroughly. (See Cleaning Section.)
⚠CAUTION: Do not line the bottom tray with aluminum foil.	Is the bottom tray "dirty" and not allowing grease to flow into catch pan?	Clean bottom tray.
Burner flame pattern is erratic. Flame is low when burner is on HIGH. Flames do not run the whole length of the burner tube.	Are burners clean?	Clean burners. (See Maintenance Section.)
Inside of lid appears to be "peeling." (Resembles paint peeling.)	The lid is porcelain-on-steel, not paint. It cannot "peel." What you are seeing is baked on grease that has turned to carbon and is flaking off. <b>THIS IS NOT A DEFECT.</b>	Clean thoroughly. (See Cleaning Section.)
Fuel scale shows that there is gas in the LP tank, but tank is empty.	Check adjustment of fuel scale.	Fuel scale must be adjusted with an empty tank.

If problems cannot be corrected by using these methods, please contact Weber-Stephen Customer Service.

# SIDE BURNER TROUBLESHOOTING

For the Platinum Series II 3200 & 3400

**⚠WARNING:** Before attempting any troubleshooting steps, all gas controls and supply valves should be in the OFF position.

<b>Problem</b>	<b>Check</b>	<b>Cure</b>
Side burner does not light.	Is gas supply off?	Turn supply on.
Flame is low in HIGH position.	Is fuel hose bent or kinked?	Straighten hose.
Flame is very yellow in conjunction with the smell of gas,  OR  Burner makes popping noise in conjunction with the smell of gas.	Inspect burner ring slots for obstructions. Inspect burner base for obstructions.	Clean if necessary.
Push button ignition does not work.	Does burner light with a match?	If match lights burner, check igniter (see Side Burner Maintenance).
Flame is large or erratic.	Is the burner ring correctly installed?	See Side Burner Maintenance for correct assembly.



# SIDE BURNER MAINTENANCE

**⚠WARNING: All gas controls and supply valves should be in the OFF position. Figure 17 (a).** Make sure black wire is connected between igniter and electrode. Make sure white wire is connected between igniter and ground. Check that igniter lock nut is tight. Figure 17 (b) and figure 17 (c).

*Note - If the igniter works loose, carefully tighten the igniter lock nut with an adjustable wrench or pliers.*

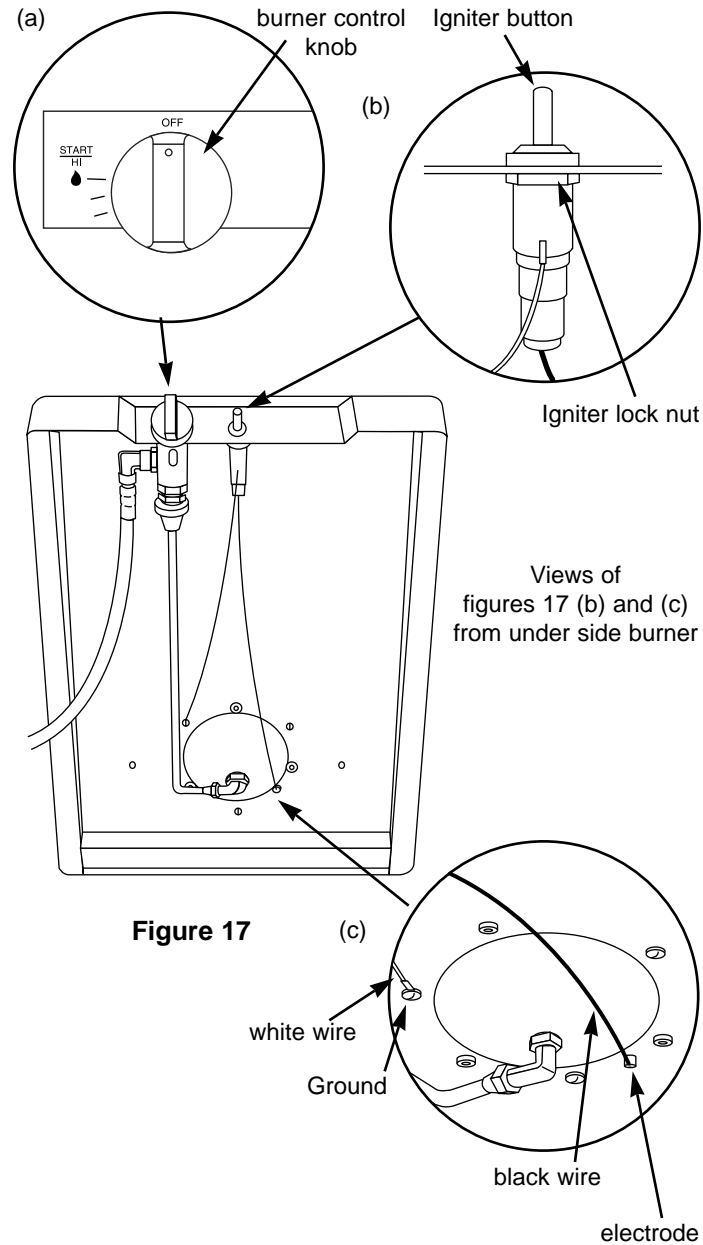

**Figure 17**

The Platinum Series II side burner has been factory set for the correct air and gas mixture. The correct flame pattern is shown in Figure 18.

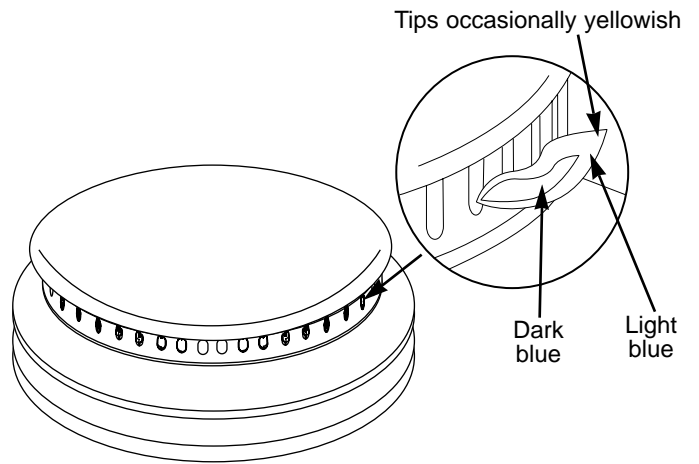

**Figure 18**

# SIDE BURNER MAINTENANCE

## To Clean the Burner Head

Remove the windshield and grate. Remove the burner cap. Figure 19 (a). Clean with soap and water. Soak if necessary.

Remove the burner ring. Figure 19 (b). Clean with soap and water. Soak if necessary.

**⚠CAUTION: Do not enlarge the slots in the burner ring. Only clean with a cloth and soap and water.** Remove the burner head. Figure 19 (c). Clean with soap and water. Soak if necessary.

Wipe out the burner base with a damp cloth and soap and water.

**⚠CAUTION: Avoid getting water or dust in the burner orifice.**

Clean the ignition electrode with a damp cloth and soap and water.

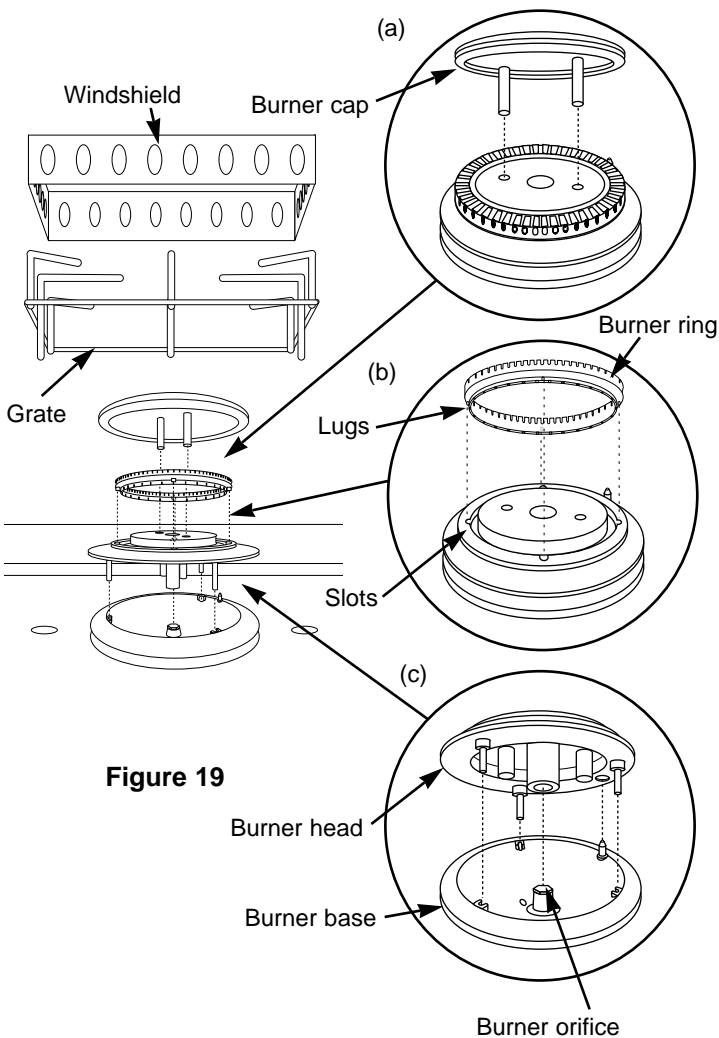

Figure 19

## To Reassemble the Burner Head

Insert the burner head into the burner base. Figure 19 (c). There is a hole in the burner head for the igniter electrode.

Set the burner ring onto the burner head. Rotate the burner ring until the four lugs on the burner ring are seated in the four slots on the burner head. Figure 19 (b).

**⚠WARNING: If the flame pattern is uneven or erratic, turn OFF the burner control knob. Check the position of the burner ring to the burner head. The lugs of the burner ring must be in the slots of the burner head.**

Install the burner cap. Figure 19 (a). Install the grate and the windshield.

## SIDE BURNER EXPLODED VIEW

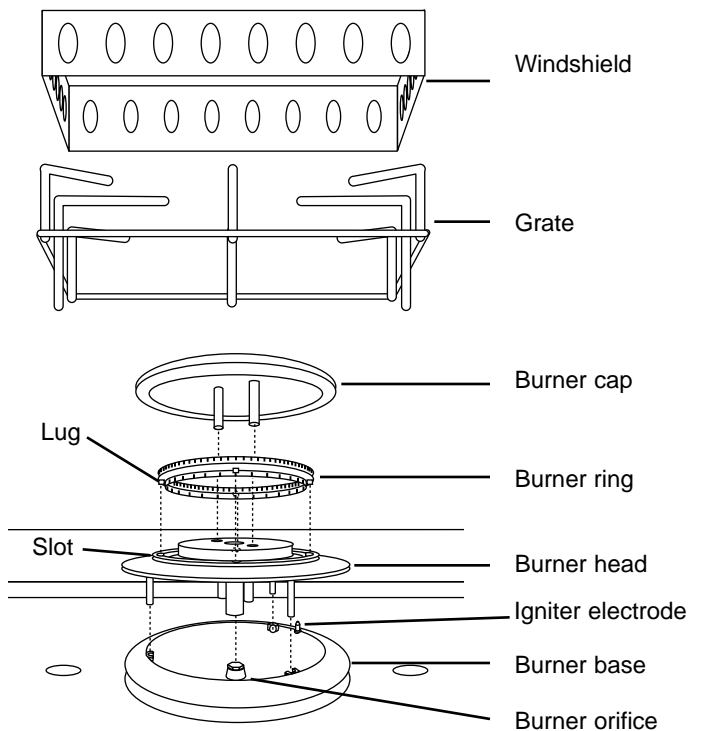

Burner assembly consists of: burner cap, burner ring, burner head, burner base, and burner orifice.

*Note: The burner head has a hole in it that fits over the igniter electrode.*

# PLATINUM SERIES II 2200 LP EXPLODED VIEW

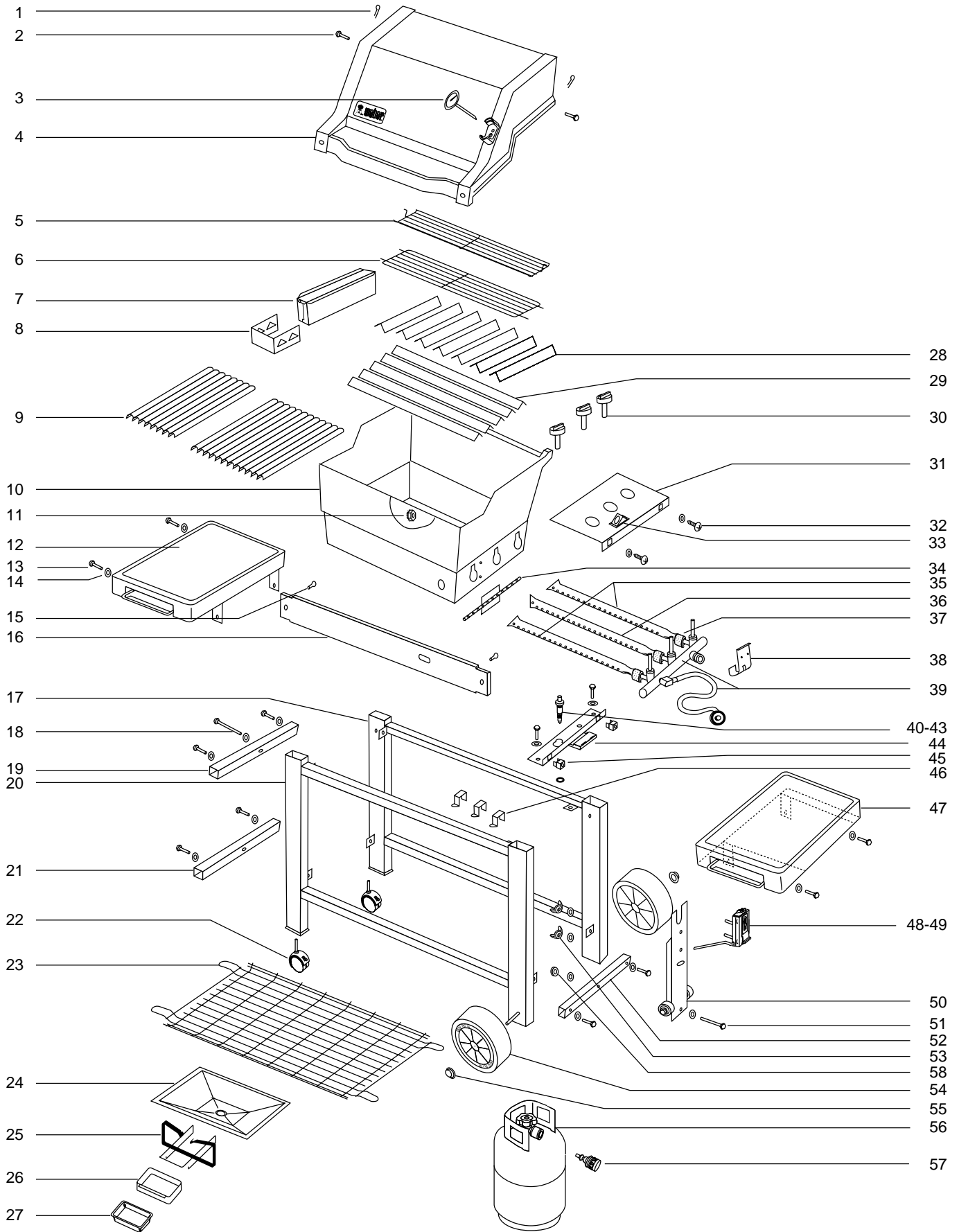

# PLATINUM SERIES II 2200 LP REPLACEMENT PARTS LIST

- |    |                             |    |                   |
|----|-----------------------------|----|-------------------|
| 1  | Hinge pin cotter (2)        | 53 | Wing nut (2)      |
| 2  | Hinge pin (2)               | 54 | Wheel (2)         |
| 3  | Thermometer                 | 55 | Wheel hub cap (2) |
| 4  | Lid (assembly)              | 56 | LP tank           |
| 5  | Weber warm-up basket        | 57 | Filler adapter    |
| 6  | Warming rack                | 58 | 1/4-20 nut        |
| 7  | Steam-N-Chips Smoker        |    |                   |
| 8  | Steam-N-Chips Smoker flue   |    |                   |
| 9  | Cooking grate (2)           |    |                   |
| 10 | Cooking box                 |    |                   |
| 11 | Keys nut                    |    |                   |
| 12 | Left work surface           |    |                   |
| 13 | 1/4-20 x 1/2 inch bolt (12) |    |                   |
| 14 | Nylon washer (19)           |    |                   |
| 15 | Plastic button (2)          |    |                   |
| 16 | Front panel                 |    |                   |
| 17 | Rear frame                  |    |                   |
| 18 | 1/4-20 x 1 1/2 inch bolt    |    |                   |
| 19 | Crossover frame             |    |                   |
| 20 | Front frame                 |    |                   |
| 21 | Crossover frame             |    |                   |
| 22 | Caster (2)                  |    |                   |
| 23 | Bottom rack                 |    |                   |
| 24 | Bottom tray                 |    |                   |
| 25 | Catch pan holder            |    |                   |
| 26 | Catch pan                   |    |                   |
| 27 | Drip pan (2)                |    |                   |
| 28 | Short Flavorizer bars (7)   |    |                   |
| 29 | Long Flavorizer bars (5)    |    |                   |
| 30 | Burner control knobs (3)    |    |                   |
| 31 | Control panel               |    |                   |
| 32 | Phillips screw (2)          |    |                   |
| 33 | Igniter button              |    |                   |
| 34 | Crossover tube              |    |                   |
| 35 | Front or back burner        |    |                   |
| 36 | Middle burner               |    |                   |
| 37 | Spider stopper guards (3)   |    |                   |
| 38 | Manifold bracket            |    |                   |
| 39 | Manifold assembly           |    |                   |
| 40 | Igniter                     |    |                   |
| 41 | Igniter lock nut            |    |                   |
| 42 | Igniter wire (white)        |    |                   |
| 43 | Igniter wire (black)        |    |                   |
| 44 | Igniter bracket             |    |                   |
| 45 | Nylon bracket (2)           |    |                   |
| 46 | Tool holder (3)             |    |                   |
| 47 | Right work surface          |    |                   |
| 48 | Fuel scale assembly         |    |                   |
| 49 | 1/4-20 wing nut (2)         |    |                   |
| 50 | Tank panel assembly         |    |                   |
| 51 | 1/4-20 x 1 3/4 inch bolt    |    |                   |
| 52 | Crossover bar               |    |                   |

All items are single quantities unless otherwise specified.

Parts can be ordered directly from Weber-Stephen Products Company by phone or mail.

*Note - Do not return parts to Weber-Stephen Products Co. without first contacting the Customer Service Center by phone or mail. Returning the part may not be necessary.*

While we give much attention to our products, unfortunately an occasional error may occur. If a part is missing, do not go back to the store. Call the Weber Customer Service Center toll free **1-800-446-1071** to receive immediate assistance. Have your owner's manual and serial number of the barbecue available for reference.

**Weber-Stephen Products Company**  
**Customer Service Center**  
**250 South Hicks Road**  
**Palatine, IL 60067-6241**  
**(800) 446-1071**



**⚠WARNING:**  
**Use only Weber factory authorized parts. The use of any part that is not factory authorized can be dangerous. This will also void your warranty.**

# PLATINUM SERIES II 3200 LP EXPLODED VIEW

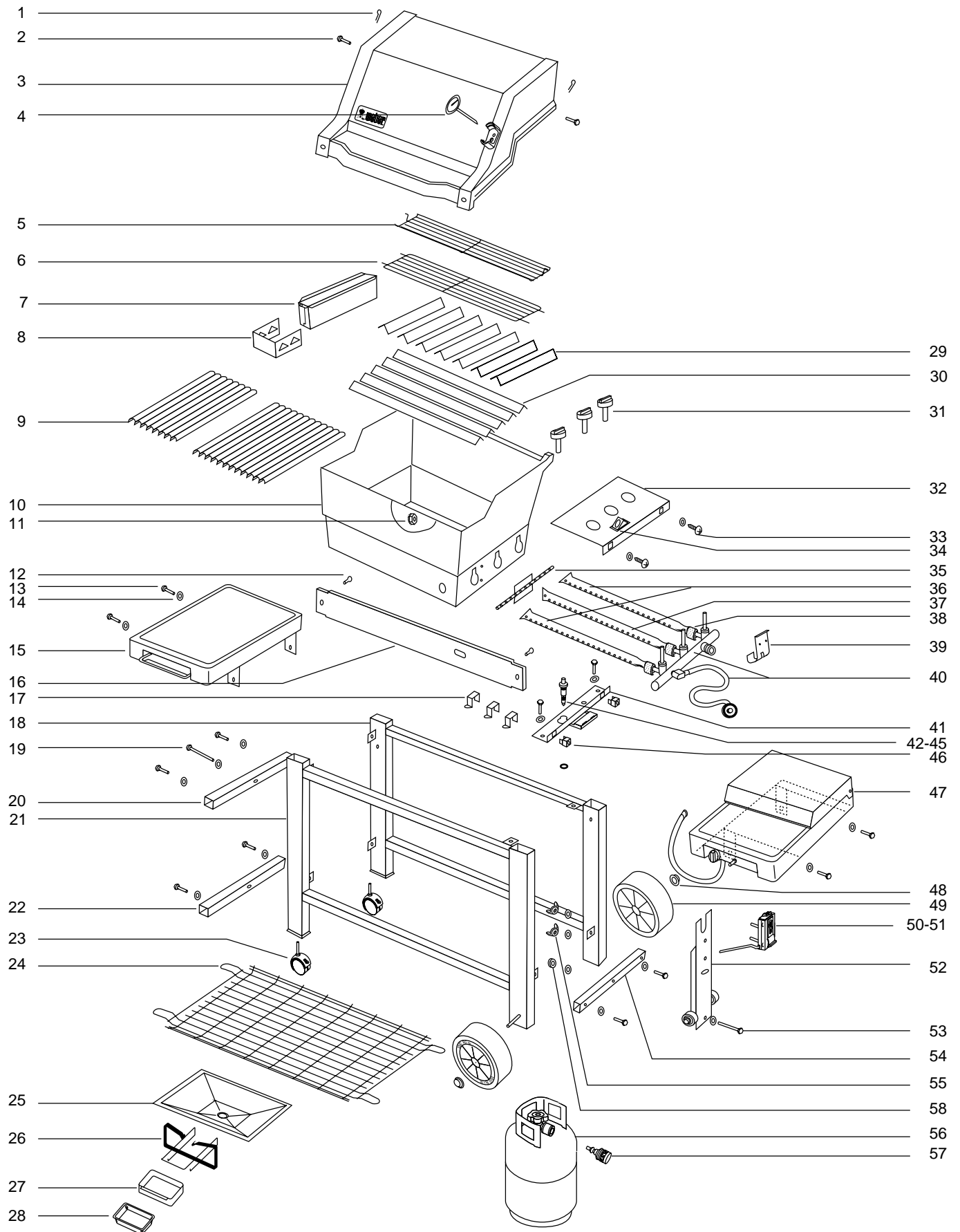

# PLATINUM SERIES II 3200 LP REPLACEMENT PARTS LIST

- |    |                             |    |                          |
|----|-----------------------------|----|--------------------------|
| 1  | Hinge pin cotter (2)        | 53 | 1/4-20 x 1 3/4 inch bolt |
| 2  | Hinge pin (2)               | 54 | Crossover rail           |
| 3  | Lid (assembly)              | 55 | Wing nut                 |
| 4  | Thermometer                 | 56 | LP tank                  |
| 5  | Weber warm-up basket        | 57 | Filler adapter           |
| 6  | Warming rack                | 58 | 1/4-20 nut               |
| 7  | Steam-N-Chips Smoker        |    |                          |
| 8  | Steam-N-Chips Smoker flue   |    |                          |
| 9  | Cooking grate (2)           |    |                          |
| 10 | Cooking box                 |    |                          |
| 11 | Keps nut                    |    |                          |
| 12 | Plastic plug (2)            |    |                          |
| 13 | 1/4-20 x 1/2 inch bolt (12) |    |                          |
| 14 | Nylon washer (19)           |    |                          |
| 15 | Left work surface           |    |                          |
| 16 | Front panel                 |    |                          |
| 17 | Tool holder (3)             |    |                          |
| 18 | Rear frame                  |    |                          |
| 19 | 1/4-20 x 1 1/2 inch bolt    |    |                          |
| 20 | Crossover rail              |    |                          |
| 21 | Front frame                 |    |                          |
| 22 | Crossover rail              |    |                          |
| 23 | Caster (2)                  |    |                          |
| 24 | Bottom rack                 |    |                          |
| 25 | Bottom tray                 |    |                          |
| 26 | Catch pan holder            |    |                          |
| 27 | Catch pan                   |    |                          |
| 28 | Drip pan (2)                |    |                          |
| 29 | Short Flavorizer bars (7)   |    |                          |
| 30 | Long Flavorizer bars (5)    |    |                          |
| 31 | Burner control knobs (3)    |    |                          |
| 32 | Control panel               |    |                          |
| 33 | Phillips screw (2)          |    |                          |
| 34 | Igniter button              |    |                          |
| 35 | Crossover tube              |    |                          |
| 36 | Front or back burner        |    |                          |
| 37 | Middle burner               |    |                          |
| 38 | Spider stopper guards (3)   |    |                          |
| 39 | Manifold bracket            |    |                          |
| 40 | Manifold assembly           |    |                          |
| 41 | Igniter bracket             |    |                          |
| 42 | Igniter                     |    |                          |
| 43 | Igniter wing nut            |    |                          |
| 44 | Igniter wire (white)        |    |                          |
| 45 | Igniter wire (black)        |    |                          |
| 46 | Plastic bracket (2)         |    |                          |
| 47 | Side burner assembly        |    |                          |
| 48 | Wheel hub cap (2)           |    |                          |
| 49 | Wheel (2)                   |    |                          |
| 50 | Fuel scale assembly         |    |                          |
| 51 | 1/4-20 wing nut (2)         |    |                          |
| 52 | Tank panel assembly         |    |                          |

All items are single quantities unless otherwise specified.

Parts can be ordered directly from Weber-Stephen Products Company by phone or mail.

*Note - Do not return parts to Weber-Stephen Products Co. without first contacting the Customer Service Center by phone or mail. Returning the part may not be necessary.*

While we give much attention to our products, unfortunately an occasional error may occur. If a part is missing, do not go back to the store. Call the Weber Customer Service Center toll free **1-800-446-1071** to receive immediate assistance. Have your owner's manual and serial number of the barbecue available for reference.

**Weber-Stephen Products Company**  
**Customer Service Center**  
**250 South Hicks Road**  
**Palatine, IL 60067-6241**  
**(800) 446-1071**



**⚠WARNING:**  
**Use only Weber factory authorized parts. The use of any part that is not factory authorized can be dangerous. This will also void your warranty.**

# PLATINUM SERIES II 3400 LP EXPLODED VIEW

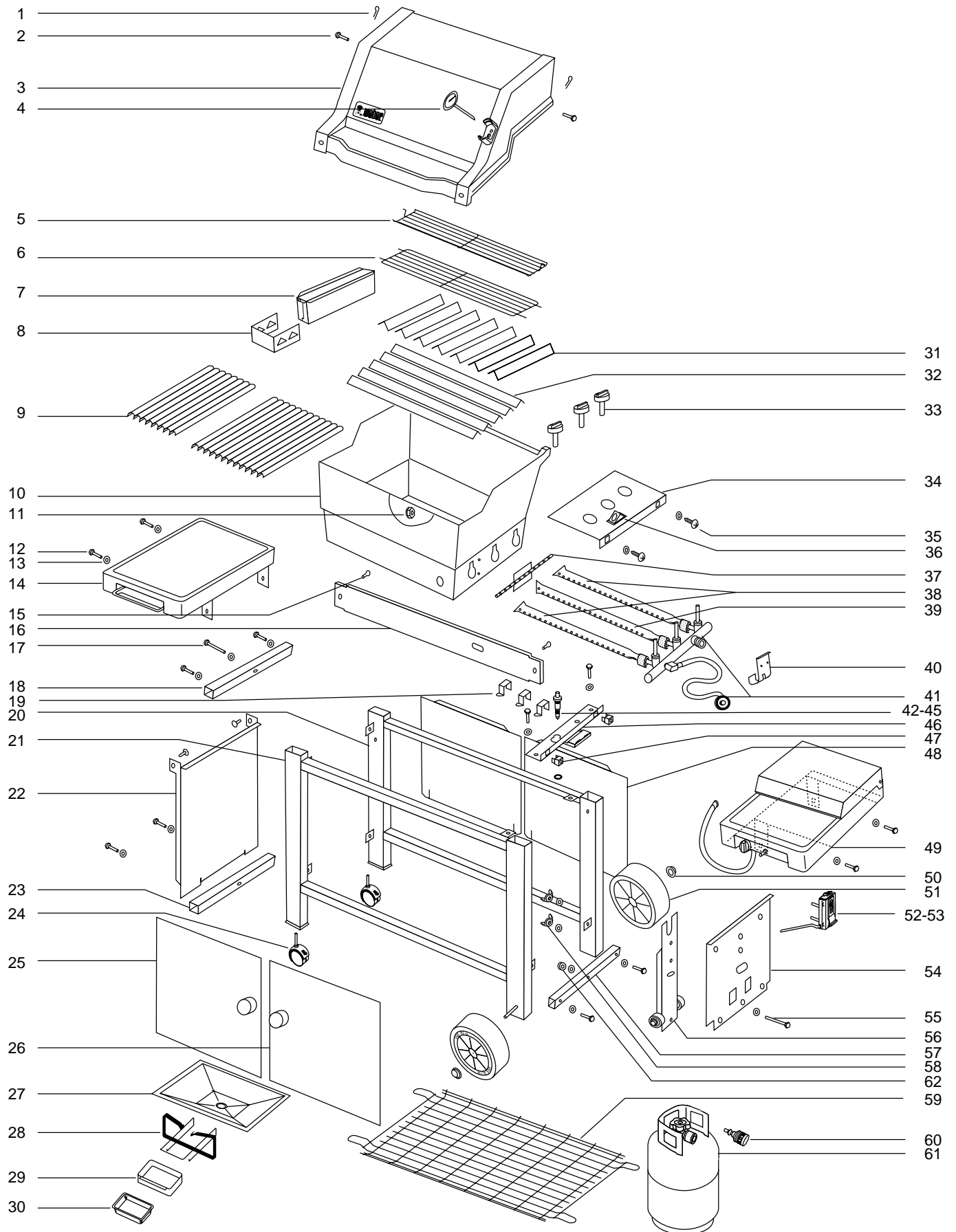



# PLATINUM SERIES II 3400 LP REPLACEMENT PARTS LIST

- 1 Hinge pin cotter (2)
- 2 Hinge pin (2)
- 3 Lid (assembly)
- 4 Thermometer
- 5 Weber warm-up basket
- 6 Warming rack
- 7 Steam-N-Chips Smoker
- 8 Steam-N-Chips Smoker flue
- 9 Cooking grate (2)
- 10 Cooking box
- 11 Keys nut
- 12 1/4-20 x 1/2 inch bolt (12)
- 13 Nylon washer (19)
- 14 Left work surface
- 15 Plastic plug (2)
- 16 Front panel
- 17 1/2-20 x 1 1/2 inch bolt
- 18 Crossover rail
- 19 Tool holder (3)
- 20 Rear frame
- 21 Front frame
- 22 Left end panel
- 23 Crossover rail
- 24 Caster (2)
- 25 Left front door
- 26 Right front door
- 27 Bottom tray
- 28 Catch pan holder
- 29 Catch pan
- 30 Drip pan (2)
- 31 Short Flavorizer bars (7)
- 32 Long Flavorizer bars (5)
- 33 Burner control knobs (3)
- 34 Control panel
- 35 Phillips screw (2)
- 36 Igniter button
- 37 Crossover tube
- 38 Front or back burner
- 39 Middle burner
- 40 Manifold bracket
- 41 Manifold assembly
- 42 Igniter
- 43 Igniter lock nut
- 44 Igniter wire (white)
- 45 Igniter wire (black)
- 46 Igniter bracket
- 47 Nylon bracket (2)
- 48 Back panel (2)
- 49 Side burner assembly
- 50 Wheel hub cap (2)
- 51 Wheel (2)
- 52 Fuel scale assembly
- 53 1/4-20 wing nut (2)
- 54 Right end panel
- 55 1/4-20 x 1 3/4 inch bolt

- 56 Tank panel assembly
- 57 Crossover rail
- 58 Wing nut
- 59 Bottom wire rack
- 60 Filler adapter
- 61 LP tank
- 62 1/4-20 nut

All items are single quantities unless otherwise specified.

Parts can be ordered directly from Weber-Stephen Products Company by phone or mail.

*Note - Do not return parts to Weber-Stephen Products Co. without first contacting the Customer Service Center by phone or mail. Returning the part may not be necessary.*

While we give much attention to our products, unfortunately an occasional error may occur. If a part is missing, do not go back to the store. Call the Weber Customer Service Center toll free **1-800-446-1071** to receive immediate assistance. Have your owner's manual and serial number of the barbecue available for reference.

**Weber-Stephen Products Company**  
**Customer Service Center**  
**250 South Hicks Road**  
**Palatine, IL 60067-6241**  
**(800) 446-1071**

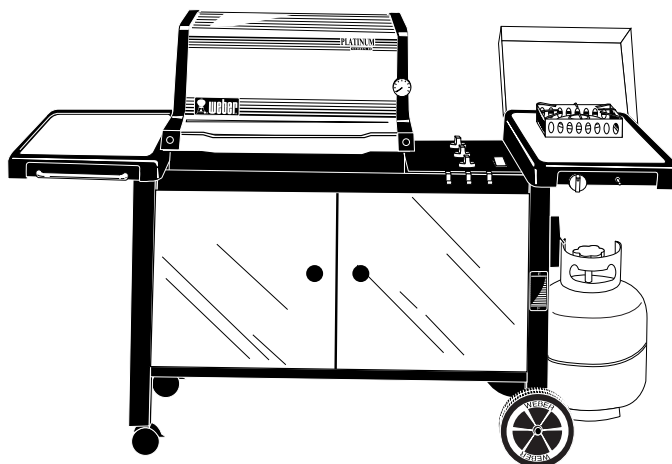

**⚠WARNING:**  
**Use only Weber factory authorized parts. The use of any part that is not factory authorized can be dangerous. This will also void your warranty.**

## **PATENTS & TRADEMARKS**

© 1998 Weber. Weber,  Genesis, Flavorizer and Crossover are registered U.S. trademarks; Perma-Mount, Gas Catcher, FlameCheck, Steam-N-Chips, Spider Stopper, and Warm-Up are U.S. trademarks of Weber-Stephen Products Co., 200 East Daniels Road, Palatine, IL 60067-6266. U.S.A. Genesis Gas Barbecues are covered under the following patent nos.: U.S.A. #4,677,964; 4,727,853; #4,777,927; #4,829,978; #4,860,724; #4,941,817; #4,966,125; #5,070,776; #D293,067; #D316,355; Canada: Rd 1987 Reg. #58,034; #1,279,540; #1,283,586; #1,300,994; #1,300,995. Printed in the U.S.A.