

SPIRIT®



GAS GRILL

Natural Gas Grill Owner's Guide

Guía del Propietario de la Barbacoa de Gas Natural - Pg 17

Guide de l'utilisateur du barbecue au gaz naturel - Pg 28

E/EP - 210/310

#89961



YOU MUST READ THIS OWNER'S GUIDE BEFORE OPERATING YOUR GAS GRILL

⚠ DANGER

If you smell gas:

1. Shut off gas to the appliance.
2. Extinguish any open flames.
3. Open lid.
4. If odor continues, keep away from the appliance and immediately call your gas supplier or your fire department.

Leaking gas may cause a fire or explosion which can cause serious bodily injury or death, or damage to property.

⚠ WARNING:

1. Do not store or use gasoline or other flammable liquids or vapors in the vicinity of this or any other appliance.
2. An LP cylinder not connected for use shall not be stored in the vicinity of this or any other appliance.

⚠ WARNING: Follow all leak-check procedures carefully in this manual prior to barbecue operation. Do this even if the barbecue was dealer-assembled.

NOTICE TO INSTALLER: These instructions must be left with the owner and the owner should keep them for future use.

THIS GAS APPLIANCE IS DESIGNED FOR OUTDOOR USE ONLY.

⚠ WARNING: Do not try to light this appliance without reading the "Lighting Instructions" section of this manual.



⚠ DANGER

Failure to follow the Dangers, Warnings and Cautions contained in this Owner's Manual may result in serious bodily injury or death, or in a fire or an explosion causing damage to property.

⚠ WARNINGS

- ⚠ Do not store a spare or disconnected liquid propane cylinder under or near this barbecue.
- ⚠ Improper assembly may be dangerous. Please follow the assembly instructions carefully.
- ⚠ After a period of storage, and/or nonuse, the Weber® gas barbecue should be checked for gas leaks and burner obstructions before use. See instructions in this manual for correct procedures.
- ⚠ Do not operate the Weber® gas barbecue if there is a gas leak present.
- ⚠ Do not use a flame to check for gas leaks.
- ⚠ Combustible materials should never be within 24 inches (61 cm) of the back or sides of your Weber® gas barbecue.
- ⚠ Do not put a barbecue cover or anything flammable on, or in the storage area under the barbecue.
- ⚠ Your Weber® gas barbecue should never be used by children. Accessible parts of the barbecue may be very hot. Keep young children away while it is in use.
- ⚠ You should exercise reasonable care when operating your Weber® gas barbecue. It will be hot during cooking or cleaning and should never be left unattended, or moved while in operation.
- ⚠ Should the burners go out while in operation, turn all gas valves off. Open the lid and wait five minutes before attempting to relight, using the lighting instructions.
- ⚠ Do not use charcoal or lava rock in your Weber® gas barbecue.
- ⚠ Never lean over open grill or place hands or fingers on the front edge of the cooking box.
- ⚠ Should a grease fire occur, turn off all burners and leave lid closed until fire is out.
- ⚠ Do not enlarge valve orifices or burner ports when cleaning the valves or burners.
- ⚠ The Weber® gas barbecue should be thoroughly cleaned on a regular basis.
- ⚠ Liquid propane gas is not natural gas. The conversion or attempted use of natural gas in a liquid propane unit or liquid propane gas in a natural gas unit is dangerous and will void your warranty.
- ⚠ Do not attempt to disconnect any gas fitting while your barbecue is in operation.
- ⚠ Use heat-resistant barbecue mitts or gloves when operating barbecue.
- ⚠ Keep any electrical supply cord and the fuel supply hose away from any heated surfaces.
- ⚠ Combustion byproducts produced when using this product contain chemicals known to the state of California to cause cancer, birth defects, or other reproductive harm.
- ⚠ Do not use this barbecue unless all parts are in place. The unit must be properly assembled according to the assembly instructions.
- ⚠ Do not build this model of grill in any built-in or slide in construction. Ignoring this Warning could cause a fire or an explosion that can damage property and cause serious bodily injury or death.
- ⚠ Proposition 65 Warning: Handling the brass material on this product exposes you to lead, a chemical known to the state of California to cause cancer, birth defects or other reproductive harm.
(Wash hands after handling this product.)

LIQUID PROPANE GAS UNITS ONLY:

- ⚠ Use the pressure regulator and hose assembly that is supplied with your Weber® gas barbecue.
- ⚠ Do not attempt to disconnect the gas regulator and hose assembly or any gas fitting while your barbecue is in operation.
- ⚠ A dented or rusty liquid propane cylinder may be hazardous and should be checked by your liquid propane supplier. Do not use a liquid propane cylinder with a damaged valve.
- ⚠ Although your liquid propane cylinder may appear to be empty, gas may still be present, and the cylinder should be transported and stored accordingly.
- ⚠ If you see, smell or hear the hiss of escaping gas from the liquid propane cylinder:
 1. Move away from liquid propane cylinder.
 2. Do not attempt to correct the problem yourself.
 3. Call your fire department.

Weber-Stephen Products Co. (Weber) hereby warrants to the ORIGINAL PURCHASER of this Weber® gas grill that it will be free of defects in material and workmanship from the date of purchase as follows:

Aluminum castings	25-years (2 years on paint; excludes fading)
Stainless steel Shroud	25-years
Porcelain-enamelled shroud	25-years
Cookbox Assembly	10-years (2 year on paint excludes fading)
Stainless steel burners tubes	10-years
Stainless steel cooking grates	5-years no rust through or burn through
Stainless steel Flavorizer bars	5-years no rust through or burn through
Porcelain-enamelled cast-iron cooking grates	5-year no rust through or burn through
Porcelain-enamelled cooking grates	3-years no rust through or burn through
Porcelain-enamelled Flavorizer bars	2-years no rust through or burn through
Infrared Rotisserie Burner	2-years
All remaining parts	2-years

When assembled and operated in accordance with the printed instructions accompanying it. Weber may require reasonable proof of your date of purchase. THEREFORE, YOU SHOULD RETAIN YOUR SALES SLIP OR INVOICE.

This Limited Warranty shall be limited to the repair or replacement of parts that prove defective under normal use and service and which on examination shall indicate, to Weber's satisfaction, they are defective. Before returning any parts, contact the Customer Service Representative in your area using the contact information on our website. If Weber confirms the defect and approves the claim, Weber will elect to replace such parts without charge. If you are required to return defective parts, transportation charges must be prepaid. Weber will return parts to the purchaser, freight or postage prepaid.

This Limited Warranty does not cover any failures or operating difficulties due to accident, abuse, misuse, alteration, misapplication, vandalism, improper installation or improper maintenance or

Weber-Stephen Products Co., (Weber) mediante la presente le garantiza al COMPRADOR ORIGINAL de esta barbacoa de gas Weber® que la misma estará libre de defectos en cuanto a materiales y fabricación a partir de la fecha de compra según lo siguiente:

Piezas coladas de aluminio	25-años (2 años para la pintura excluyendo la decoloración)
Cubierta de acero inoxidable	25-años
Cubierta porcelanizada	25-años
Cámara para asar	10-años (2 años para la pintura excluyendo la decoloración)
Tubos de acero inoxidable de los quemadores	10-años
Parrillas de cocción de acero inoxidable	5-años sin perforación por fuego u oxidación
Barras Flavorizer de acero inoxidable	5-años sin perforación por fuego u oxidación
Parrillas de cocción de hierro colado porcelanizado	5-años sin perforación por fuego u oxidación
Parrillas de cocción porcelanizadas	3-años sin perforación por fuego u oxidación
Barras Flavorizer porcelanizadas	2-años sin perforación por fuego u oxidación
Quemador infrarrojo del asador giratorio	2-años
Todas la demás partes	2-años

cuando se ensambla y opera de acuerdo a las instrucciones impresas que la acompañan.

Weber pudiere requerir prueba razonable de la fecha de compra. POR LO TANTO, DEBERÁ GUARDAR SU RECIBO O FACTURA DE VENTA.

Esta garantía limitada está limitada a la reparación o reemplazo de piezas que resultasen defectuosas bajo uso y servicio normal y las cuales al examinarse indiquen, a plena satisfacción de Weber, que efectivamente son piezas defectuosas. Antes de devolver cualquier parte, contacte al Representante de Atención al Cliente en su área, cuya información de contacto la encontrará en nuestro sitio web. Si Weber confirma el defecto y aprueba el reclamo, ésta elegirá reparar o reemplazar tal pieza sin cargo alguno. Si usted tiene que retornamos las partes defectuosas, los gastos de transporte deben ser prepagados. Weber retornará las partes al comprador con transporte o franqueo prepagado.

Esta Garantía Limitada no cubre ninguna falla o problema de operación a causa de accidentes, abuso, mal uso, alteración, uso en aplicaciones indebidas, vandalismo, instalación inapropiada o mantenimiento o servicio inapropiados, o por no llevar a cabo el mantenimiento normal y rutinario,

Weber-Stephen Products Co. (Weber) garantit par le présent document à l'ACHETEUR D'ORIGINE de ce grill à gaz Weber® que celui-ci ne comportera aucun défaut de pièce ni de main d'oeuvre à compter de la date d'achat comme suit :

Fonte d'aluminium	25 ans (2 ans pour la peinture à l'exception de toute décoloration)
Structure en acier inoxydable	25 ans
Structure émaillée	25 ans
Cuve	10 ans (2 ans pour la peinture à l'exception de toute décoloration)
Tubes du brûleur en acier inoxydable	10 ans
Grilles de cuisson en acier inoxydable	5 ans sans trou provoqué par la rouille ou par une brûlure
Barras Flavorizer en acier inoxydable	5 ans sans trou provoqué par la rouille ou par une brûlure
Grilles de cuisson en fonte émaillée	5 ans sans trou provoqué par la rouille ou par une brûlure
Grilles de cuisson émaillées	3 ans sans trou provoqué par la rouille ou par une brûlure
Barras Flavorizer émaillées	2 ans sans trou provoqué par la rouille ou par une brûlure
Brûleur de la rôtissoire à infrarouge	2 ans
Toutes les autres pièces	2 ans

à condition qu'il ait été assemblé et utilisé conformément aux instructions imprimées qui l'accompagnent.

Weber peut exiger une preuve raisonnable de votre date d'achat. VOUS DEVRIEZ DONC CONSERVER VOTRE TICKET DE CAISSE OU VOTRE FACTURE.

La présente Garantie limitée est limitée à la réparation ou au remplacement des pièces qui s'avèrent défectueuses dans le cadre d'une utilisation normale et d'un entretien normal et dont l'examen indique, à la satisfaction de Weber, qu'elles sont défectueuses. Avant de retourner toute pièce, veuillez entrer en contact avec le Représentant du Service clientèle le plus proche grâce aux coordonnées à votre disposition sur notre site Internet. Si Weber confirme le défaut et approuve la demande, Weber choisira de remplacer ces pièces sans frais. S'il vous est demandé de retourner les pièces défectueuses, les frais de transport devront être prépayés. Weber retournera les pièces à l'acheteur, franco de port.

La présente Garantie limitée ne couvre pas toute défaillance ou difficulté d'utilisation provoquée par un accident, une utilisation abusive, une mauvaise utilisation, une altération, une mauvaise application, un acte de vandalisme, une installation incorrecte ou une maintenance ou un entretien incorrects, ou le

service, or failure to perform normal and routine maintenance, including but not limited to damage caused by insects within the burner tubes, as set out in this owner's manual. Deterioration or damage due to severe weather conditions such as hail, hurricanes, earthquakes or tornadoes, discoloration due to exposure to chemicals either directly or in the atmosphere, is not covered by this Limited Warranty.

There are no other express warrants except as set forth herein and any applicable implied warranties of merchantability and fitness are limited in duration to the period of coverage of this express written Limited Warranty. Some regions do not allow limitation on how long an implied warranty lasts, so this limitation may not apply to you.

Weber is not liable for any special, indirect or consequential damages. Some regions do not allow the exclusion or limitation of incidental or consequential damages, so this limitation or exclusion may not apply to you.

Weber does not authorize any person or company to assume for it any other obligation or liability in connection with the sale, installation, use, removal, return, or replacement of its equipment; and no such representations are binding on Weber.

This Warranty applies only to products sold at retail.

WEBER-STEPHEN PRODUCTS CO.

Customer Service Center
1890 Roselle Road, Suite 308
Schaumburg, IL 60195
USA

For replacement parts call:
1-800-446-1071
www.weber.com®

entre los que se incluyen, pero sin limitación, los daños causados por insectos dentro de los tubos quemadores, según se detalla en este manual del propietario.

Esta Garantía Limitada no cubre el deterioro o daños a causa de condiciones de tiempo inclemente tales como granizo, huracanes, terremotos o tornados ni tampoco la decoloración por exposición a sustancias químicas bien sea por contacto directo o por que las mismas contenidas en la atmósfera.

No existe ninguna otra garantía expresa que no sean las las acá indicadas y cualesquier garantías implícitas de comerciabilidad y aptitud de uso están limitadas en duración al tiempo de cobertura de esta expresa Garantía Limitada por escrito. Algunas regiones no permiten limitación alguna en el tiempo que una garantía implícita pueda durar, por lo que esta limitación pudiera no aplicarle a usted. Weber no se hace responsable de cualesquier daños especiales, indirectos o emergentes. Algunas regiones no permiten la exclusión o limitación de daños incidentales o emergentes, por lo que esta limitación o exclusión pudieran no aplicarle a usted.

Weber no autoriza a persona o empresa alguna a asumir en su nombre ninguna obligación o responsabilidad en relación con la venta, instalación, uso, retiro, devolución o reemplazo de sus equipos, y ninguna tal representación será vinculante para Weber.

Esta Garantía aplica solo a aquellos productos vendidos al por menor.

WEBER-STEPHEN PRODUCTS CO.

Customer Service Center
1890 Roselle Road, Suite 308
Schaumburg, IL 60195
USA

Para partes de repuesto llame a:
1-800-446-1071
www.weber.com®

Para compras hechas en México
WEBER-STEPHEN PRODUCTS S.A. de C.V.
Marcella No. 338,
Colonia Americana
44160 México, C.P.
México

Para partes de repuesto llame a:
(52) (33) 3615-0736
www.weber.com®

défaut d'entretien normal et régulier, y compris mais pas seulement les dommages provoqués par des insectes à l'intérieur des tubes du brûleur, tel que décrit dans le présent mode d'emploi.

Toute détérioration ou tout dommage résultant de conditions météorologiques graves comme de la grêle, des ouragans, des séismes ou des tornades, toute décoloration résultant d'une exposition à des agents chimiques directement ou dans l'atmosphère, n'est pas couverte dans le cadre de la présente Garantie limitée.

Il n'existe aucune autre garantie expresse hormis celles exposées dans le présent document et toute garantie de commercialisation et de bon état induite est limitée en durée à la période de couverture de la présente Garantie limitée écrite expresse. Certaines régions n'autorisent pas de limitation de durée de la garantie induite ; il est donc possible que cette limitation ne s'applique pas à vous.

Weber ne peut être tenu pour responsable de tout dommage particulier, induit ou se produisant par voie de conséquence. Certaines régions n'autorisent pas l'exclusion ou la limitation des dommages indirects ou se produisant par voie de conséquence ; il est donc possible que cette limitation ou exclusion ne s'applique pas à vous.

Weber n'autorise aucune personne ou société à présumer en son nom de toute autre obligation ou responsabilité en relation avec la vente, l'installation, l'utilisation, le retrait, le retour ou le remplacement de ses équipements ; et aucune de ces représentations ne lie Weber.

La présente Garantie s'applique uniquement aux produits vendus au détail.

WEBER-STEPHEN PRODUCTS CO.

Product Registration
P.O. Box 40530
Burlington, ON L7P 4W1

Pour des pièces de rechange, appelez le :

1-800-265-2150
www.weber.com®

VISION ÉCLATÉE, DIAGRAMA DE DESPIECE

Spirit_210_NG_US_09

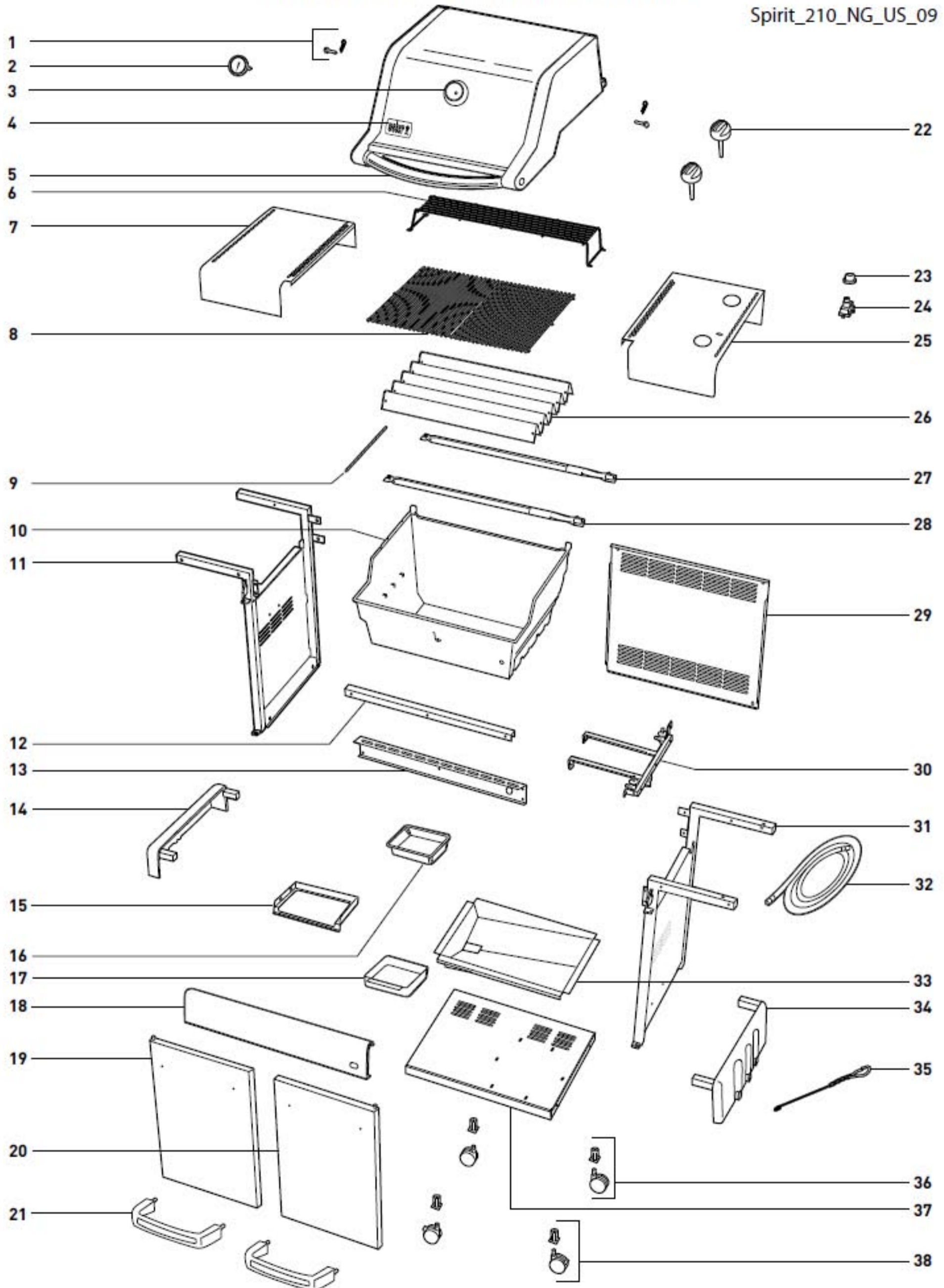

LISTA DEL DIAGRAMA DE DESPIECE, LISTE DE LA VISION ÉCLATÉE

- | | | |
|---|---|--|
| 1. Shroud Hardware
Accesorios de la cubierta
Kit d'assemblage du boîtier | 18. Front Panel
Panel frontal
Panneau avant | 35. Matchstick Holder
Portacerillos
Porte-allumette |
| 2. Thermometer
Termómetro
Thermomètre | 19. Left Door
Puerta izquierda
Porte arrière | 36. Caster
Rueda giratoria
Roulette |
| 3. Thermometer Bezel
Moldura decorativa del termómetro
Cadran de thermomètre | 20. Right Door
Puerta derecha
Porte droite | 37. Bottom Panel
Panel inferior
Panneau inférieur |
| 4. Shroud
Cubierta
Boîtier | 21. Door Handle
Asa de la puerta
Poignée de porte | 38. Locking Caster
Rueda giratoria con bloqueo
Roulette à frein |
| 5. Handle
Asa
Poignée | 22. Control Knob
Perilla de control
Bouton de commande | |
| 6. Warming Rack
Rejilla de calentamiento
Grille réchaud | 23. Igniter Button
Botón de encendido
Bouton d'allumage | |
| 7. Left Side Table
Mesa lateral izquierda
Tablette latérale gauche | 24. Igniter Module
Módulo de encendido
Module d'allumeur | |
| 8. Cooking Grates
Parrillas de cocción
Grilles de cuisson | 25. Right Side Table
Mesa lateral derecha
Tablette latérale droite | |
| 9. Crossover® Tube
Tubo Crossover®
Tube Crossover® | 26. Flavorizer® Bar
Barra Flavorizer®
Barre Flavorizer® | |
| 10. Cookbox
Caja de cocción
Cuve | 27. Rear Burner Tube
Tubo quemador posterior
Tuyau de brûleur arrière | |
| 11. Left Frame Panel
Panel izquierdo del bastidor
Panneau de cadre gauche | 28. Front Burner Tube
Tubo quemador frontal
Tuyau de brûleur avant | |
| 12. Rear Frame Support
Soporte posterior del bastidor
Support de cadre arrière | 29. Back Panel
Panel trasero
Panneau arrière | |
| 13. Front Frame Support
Soporte delantero del bastidor
Support de cadre avant | 30. Manifold
Múltiple
Collecteur | |
| 14. Left Trim Piece
Pieza de adorno izquierda
Élément de décoration gauche | 31. Right Frame Panel
Panel derecho del bastidor
Panneau de cadre droit | |
| 15. Catch Pan Holder
Soporte del plato recolector
Support de bac d'égouttage | 32. Hose
Manguera
Tuyau | |
| 16. Disposable Drip Pan
Bandeja de goteo desechable
Support de lèchefrite | 33. Drip Tray
Bandeja de goteo
Bac d'égouttage | |
| 17. Catch Pan
Plato recolector
Lèchefrite jetable | 34. Right Trim Piece
Pieza de adorno derecha
Élément de décoration droit | |

VISION ÉCLATÉE, DIAGRAMA DE DESPIECE

Spirit_310_NG_US_09

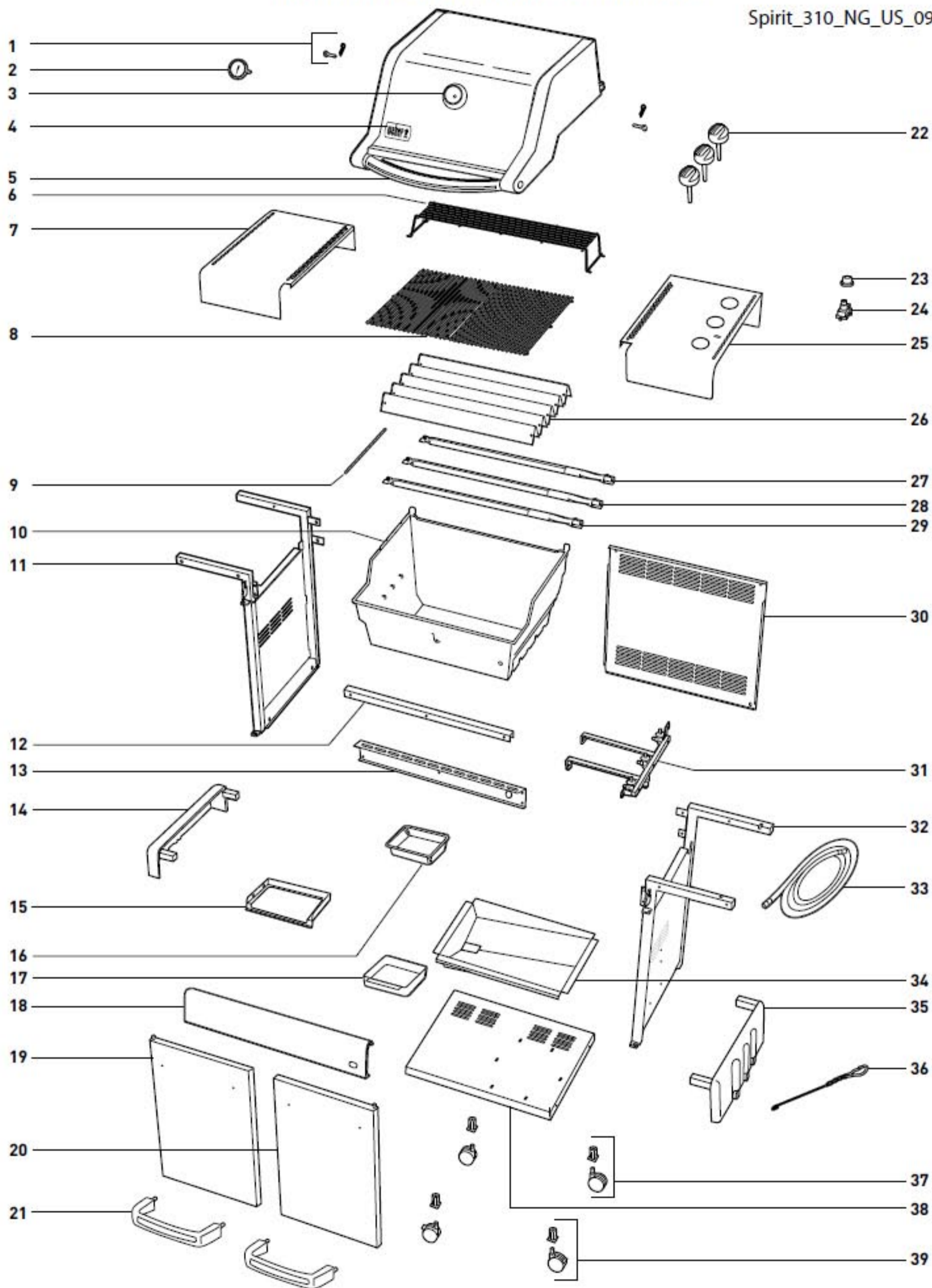

LISTA DEL DIAGRAMA DE DESPIECE, LISTE DE LA VISION ÉCLATÉE

- | | | |
|--|---|---|
| 1. Shroud Hardware
Accesorios de la cubierta
Kit d'assemblage du boîtier | 18. Front Panel
Panel frontal
Panneau avant | 35. Right Trim Piece
Pieza de adorno derecha
Élément de décoration droit |
| 2. Thermometer
Termómetro
Thermomètre | 19. Left Door
Puerta izquierda
Porte gauche | 36. Matchstick Holder
Portacerillos
Porte-allumette |
| 3. Thermometer Bezel
Moldura decorativa del termómetro
Cadran de thermomètre | 20. Right Door
Puerta derecha
Porte droite | 37. Caster
Rueda giratoria
Roulette |
| 4. Shroud
Cubierta
Boîtier | 21. Door Handle
Asa de la puerta
Poignée de porte | 38. Bottom Panel
Panel inferior
Panneau inférieur |
| 5. Handle
Asa
Poignée | 22. Control Knob
Perilla de control
Bouton de commande | 39. Locking Caster
Rueda giratoria con bloqueo
Roulette à frein |
| 6. Warming Rack
Rejilla de calentamiento
Grille réchaud | 23. Igniter Button
Botón de encendido
Bouton d'allumage | |
| 7. Left Side Table
Mesa lateral izquierda
Table latérale gauche | 24. Igniter Module
Módulo de encendido
Module | |
| 8. Cooking Grates
Parrillas de cocción
Grilles de cuisson | 25. Right Side Table
Mesa lateral derecha
Tablette latérale droit | |
| 9. Crossover® Tube
Tubo Crossover®
Tube Crossover® | 26. Flavorizer® Bar
Barra Flavorizer®
Barre de vaporisation Flavorizer® | |
| 10. Cookbox
Caja de cocción
Cuve | 27. Rear Burner Tube
Tubo quemador posterior
Tuyau du brûleur arrière | |
| 11. Left Frame Panel
Panel izquierdo del bastidor
Panneau avant | 28. Middle Burner Tube
Tubo quemador del medio
Tuyau du brûleur central | |
| 12. Rear Frame Support
Soporte posterior del bastidor
Support de cadre avant | 29. Front Burner Tube
Tubo quemador frontal
Tuyau du brûleur central avant | |
| 13. Front Frame Support
Soporte delantero del bastidor
Support de cadre arrière | 30. Back Panel
Panel trasero
Panneau arrière | |
| 14. Left Trim Piece
Pieza de adorno izquierda
Élément de décoration gauche | 31. Manifold
Múltiple
Collecteur | |
| 15. Catch Pan Holder
Soporte del plato recolector
Support de lèche-frite | 32. Right Frame Panel
Panel derecho del bastidor
Panneau de cadre avant | |
| 16. Disposable Drip Pan
Bandeja de goteo desechable
Lèche-frite jetable | 33. Hose
Manguera
Tuyau | |
| 17. Catch Pan
Plato recolector
Lèche-frite | 34. Drip Tray
Bandeja de goteo
Bac d'égouttage | |

Your Weber® gas barbecue is a portable outdoor cooking appliance. With the Weber® gas barbecue you can grill, barbecue, roast and bake with results that are difficult to duplicate with indoor kitchen appliances. The closed lid and Flavorizer® bars produce that "outdoor" flavor in the food.

The Weber® gas barbecue is portable so you can easily change its location in your yard or on your patio. Portability means you can take your Weber® gas barbecue with you if you move.

The natural gas supply is easy to use and gives you more cooking control than charcoal fuel.

- These instructions will give you the minimum requirements for assembling your Weber® gas barbecue. Please read the instructions carefully before using your Weber® gas barbecue. Improper assembly can be dangerous.
- Not for use by children.
- If there are local codes that apply to portable gas grills, you will have to conform to them. Installation must conform with local codes or, in the absence of local codes, with either the National Fuel Gas Code, ANSI Z223.1/NFPA 54, Natural Gas and Propane Installation Code, CSA B149.1, or Propane Storage and Handling Code, B149.2, or the Standard for Recreational Vehicles, ANSI A 119.2/NFPA 1192, and CSA Z240 RV Series, Recreational Vehicle Code, as applicable.
- This Weber® gas barbecue is designed for natural (piped in city) gas only. Do not use liquid propane (LP) bottled gas. The valves, orifices and hose are for natural gas only.
- Do not use with charcoal fuel.
- Check that the area under the control panel and the bottom tray are free from debris that might obstruct the flow of combustion or ventilation air.

FOR INSTALLATION IN CANADA

These instructions, while generally acceptable, do not necessarily comply with the Canadian Installation codes, particularly with piping above and below ground. In Canada the installation of this appliance must comply with local codes and/or Standards CAN/CGA-B149.1 (Installation Code for Natural Gas Burning Appliances and Equipment).

STORAGE

- The gas must be turned off at the natural gas supply when the Weber® gas barbecue is not in use.
- When the Weber® gas barbecue is stored indoors, the gas supply must be disconnected.
- The Weber® gas barbecue should be checked for gas leaks and any obstructions in the burner tubes before using. (See Section: "Maintenance/Annual Maintenance").
- Check that the areas under the control panel and the slide out bottom tray are free from debris that might obstruct the flow of combustion or ventilation air.
- The Spider /Insect Screens should also be checked for any obstructions. (See Section: "Maintenance/Annual Maintenance").

COOKING

⚠ WARNING: Do not move the Weber® gas barbecue when operating or while barbecue is hot.

You can adjust BURNER 1, 2, and 3 as desired. The control settings: High (H), Medium (M), Low (L), or Off (O) are described in your Weber® cookbook. The cookbook uses these notations to describe the settings of BURNER 1, 2, and 3. For example, to sear steaks, you would set all burners at H (high). Then to complete cooking, you would set BURNER 1 and BURNER 3 at M (medium). Refer to your Weber® cookbook for detailed cooking instructions.

Note: The temperature inside your cooking box for the first few uses, while surfaces are still very reflective, may be hotter than those shown in your cookbook. Cooking conditions such as wind and weather, may require the adjustment of the burner controls to obtain the correct cooking temperatures.

Preheating - Your Weber® gas barbecue is an energy-efficient appliance. It operates at an economical low BTU rate. To preheat: after lighting, close lid and turn all burners to high (H). Preheating to between 500° and 550° F (260° and 290° C) will take 10 to 15 minutes depending on conditions such as air temperature and wind.

Drippings and grease - The Flavorizer® bars are designed to "smoke" the correct amount of drippings for flavorful cooking. Excess drippings and grease will accumulate in the catch pan under the slide out bottom tray. Disposable foil drip pans are available that fit the catch pan.

OPERATING

- ⚠ **WARNING: Only use this barbecue outdoors in a well-ventilated area. Do not use in a garage, building, breezeway or any other enclosed area.**
- ⚠ **WARNING: Your Weber® gas barbecue shall not be used under overhead combustible construction.**
- ⚠ **WARNING: Your Weber® gas barbecue is not intended to be installed in or on recreational vehicles and/or boats.**
- ⚠ **WARNING: Do not use the barbecue within 24 inches of combustible materials. This includes the top, bottom, back or sides of the grill.**
- ⚠ **WARNING: The entire cooking box gets hot when in use. Do not leave unattended.**
- ⚠ **WARNING: Keep any electrical supply cord and the fuel supply hose away from any heated surface.**
- ⚠ **WARNING: Keep the cooking area clear of flammable vapors and liquids, such as gasoline, alcohol, etc., and combustible materials.**

GAS SUPPLY TESTING

- Disconnect your Weber® gas barbecue when the gas supply is being tested at high pressures. This appliance and its individual shutoff valve must be disconnected from the gas supply piping system during any pressure testing of that system at test pressures in excess of 1/2 psig (3.5 kPa).
- Turn off your Weber® gas barbecue when the gas supply is being tested at low pressures. This appliance must be isolated from the gas supply piping system by closing its individual manual shutoff valve during any pressure testing of the gas supply piping system at the pressure equal to or less than 1/2 psig (3.5 kPa).

⚠ **WARNING: Check the bottom tray for grease build-up before each use. Remove excess grease to avoid a grease fire in the slide out bottom tray.**

CLEANING

- ⚠ **WARNING: Turn your Weber® gas barbecue off and wait for it to cool before cleaning.**
- ⚠ **CAUTION: Do not clean your Flavorizer® bars or cooking grates in a self-cleaning oven.**

For availability of replacement cooking grates and Flavorizer® bars contact the Customer Service Representative in your area using the contact information on our website. Log onto www.weber.com

Outside surfaces - Use a warm soapy water solution to clean, then rinse with water.

- ⚠ **CAUTION: Do not use oven cleaner, abrasive cleansers (kitchen cleansers), cleaners that contain citrus products, or abrasive cleaning pads on barbecue or cart surfaces.**

Slide out Bottom tray - Remove excess grease, then wash with warm soapy water, then rinse.

Flavorizer® bars and Cooking grates - Clean with a suitable brass bristle brush. As needed, remove from grill and wash with warm soapy water, then rinse with water.

Catch pan - Disposable foil trays are available, or you can line the catch pan with aluminum foil. To clean the catch pan, wash with warm soapy water, then rinse.

Thermometer - Wipe with warm soapy water; clean with plastic scrub ball.

Inside cooking module - Brush any debris off of burner tubes. **DO NOT ENLARGE BURNER PORTS (OPENINGS)**. Wash inside of cooking box with warm soapy water and a water rinse.

Inside Lid - While lid is warm, wipe inside with paper towel to prevent grease build-up. Flaking built-up grease resembles paint flakes.

Stainless steel surfaces - Wash with a soft cloth and a soap and water solution. Be careful to scrub with the grain direction of the stainless steel.

Do not use cleaners that contain acid, mineral spirits or xylene. Rinse well after cleaning.

Preserve Your Stainless Steel - Your grill or its cabinet, lid, control panel and shelves may be made from stainless steel. To keep the stainless steel looking its best is a simple matter. Clean it with soap and water, rinse with clear water and wipe dry. For stubborn particles, the use of a non-metallic brush can be used.

⚠ IMPORTANT: Do not use a wire brush or abrasive cleaners on the stainless steel surfaces of your grill as this will cause scratches.

⚠ IMPORTANT: When cleaning surfaces be sure to rub/wipe in the direction of the grain to preserve the look of your stainless steel.

GAS INSTRUCTIONS

INSTALL GAS SUPPLY

GENERAL SPECIFICATIONS FOR PIPING

Note: Contact your local municipality for building codes regulating outdoor gas barbecue installations. In absence of Local Codes, you must conform to the latest edition of the National Fuel Gas Code: ANSI Z 223.1/NFPA 54, or CAN/CGA-B149.1, Natural Gas and Propane Installation Code. WE RECOMMEND THAT THIS INSTALLATION BE DONE BY A PROFESSIONAL.

Some of the following are general requirements taken from the latest edition of the National Fuel Gas Code: ANSI Z 223.1/NFPA 54, or CAN/CGA-B149.1, Natural Gas and Propane Installation Code for complete specifications.

- This barbecue is designed to operate at 7 inches of water column pressure (.2526 psi).
- A manual shut-off valve must be installed outdoors, immediately ahead of the quick disconnect.
- An additional manual shut-off valve indoors should be installed in the branch fuel line in an accessible location near the supply line.
- The quick disconnect connects to a 3/8 inch NPT thread from the gas source. The quick disconnect fitting is a hand-operated device that automatically shuts off the flow of gas from the source when the barbecue is disconnected.
- The quick disconnect fitting can be installed horizontally, or pointing downward. Installing the fitting with the open end pointing upward can result in collecting water and debris.
- The dust covers (supplied plastic plugs) help keep the open ends of the quick disconnect fitting clean while disconnected.
- Pipe compound should be used which is resistant to the action of natural gas when connections are made.
- The outdoor connector must be firmly attached to rigid, permanent construction.

⚠ WARNING: Do not route the 10 foot hose under a deck. The hose must be visible.

GAS LINE PIPING

- If the length of the line required does not exceed 50 feet, use a 5/8" O.D. tube. One size larger should be used for lengths greater than 50 feet.
- Gas piping may be copper tubing, type K or L; polyethylene plastic tube, with a minimum wall thickness of .062 inch; or standard weight (schedule 40) steel or wrought iron pipe.
- Copper tubing must be tin-lined if the gas contains more than 0.3 grams of hydrogen sulfide per 100 cubic feet of gas.
- Plastic tubing is suitable only for outdoor, underground use.
- Gas piping in contact with earth, or any other material which may corrode the piping, must be protected against corrosion in an approved manner.
- Underground piping must have a minimum of 18" cover.

TEST CONNECTIONS

All connections and joints must be thoroughly tested for leaks in accordance with local codes and all listed procedures in the latest edition of the National Fuel Gas Code: ANSI Z 223.1/NFPA 54, or CAN/CGA-B149.1

⚠ DANGER

Do not use an open flame to check for gas leaks. Be sure there are no sparks or open flames in the area while you check for gas leaks. This will result in a fire or explosion which can cause serious bodily injury or death and damage to property.

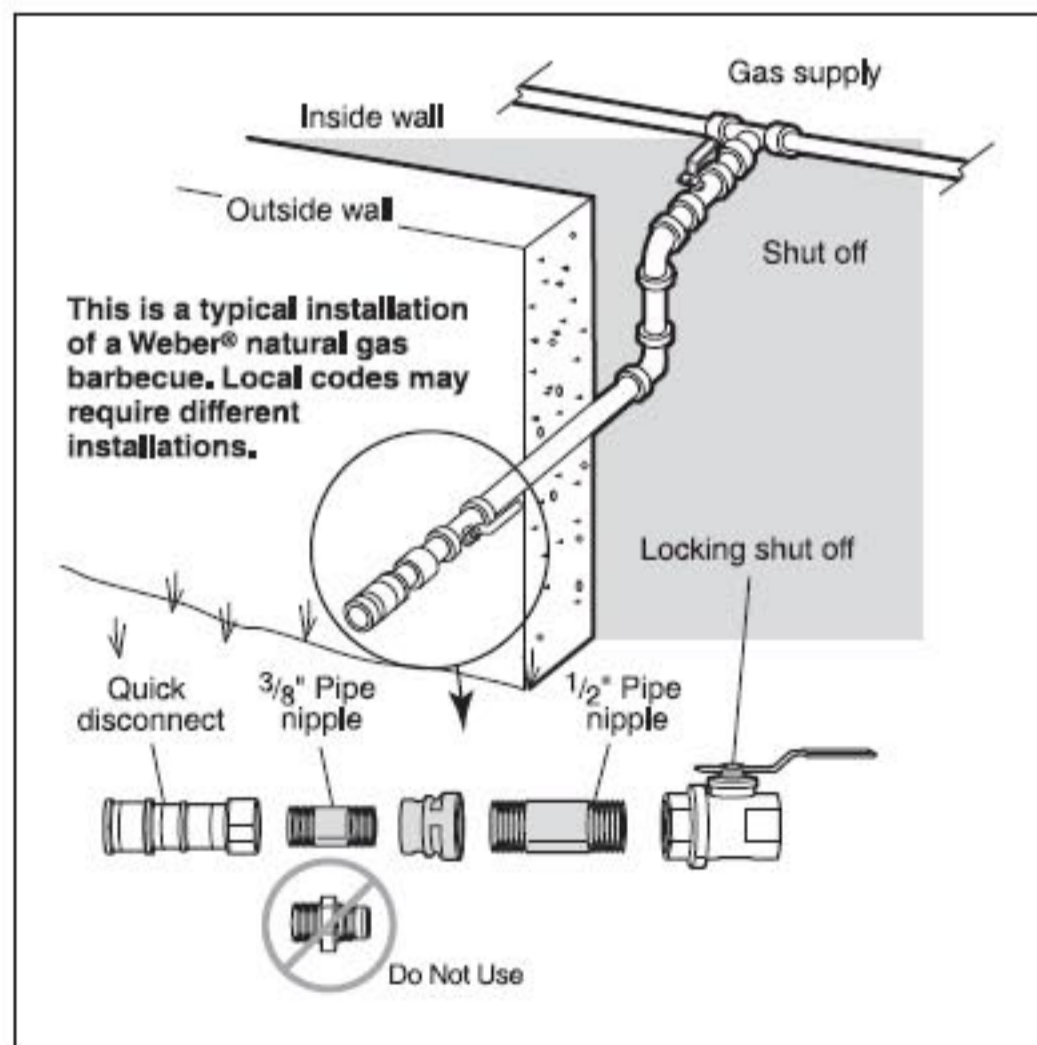

TYPE OF GAS

Your natural gas grill is factory built to operate using natural gas only. Never attempt to operate your grill on gases other than the type specified on the grill rating plates. Your grill operates at 7" of water column pressure. If replacement of the hose becomes necessary, factory specified parts are required. See your local dealer. For safety and design reasons, the conversion of a Weber® grill from operation using Natural gas to operation using LP gas requires the change out of the entire gas supply system of the grill. If this becomes necessary, see your dealer for additional information.

WHAT IS NATURAL GAS?

Natural gas, often called methane, is a safe modern fuel. Natural gas is supplied by your local utility and should be readily available if your house is already heated with gas.

PORTABLE INSTALLATION

Weber® recommends moving the grill at least two (2) feet from the gas supply and any combustible surfaces. After the gas supply has been run and checked for leaks in accordance to the assembly instructions, you are ready to grill. To connect the hose to the gas supply, pull back the outer fitting, insert the hose fitting all of the way, and release the outer fitting. This process will produce a gas joint.

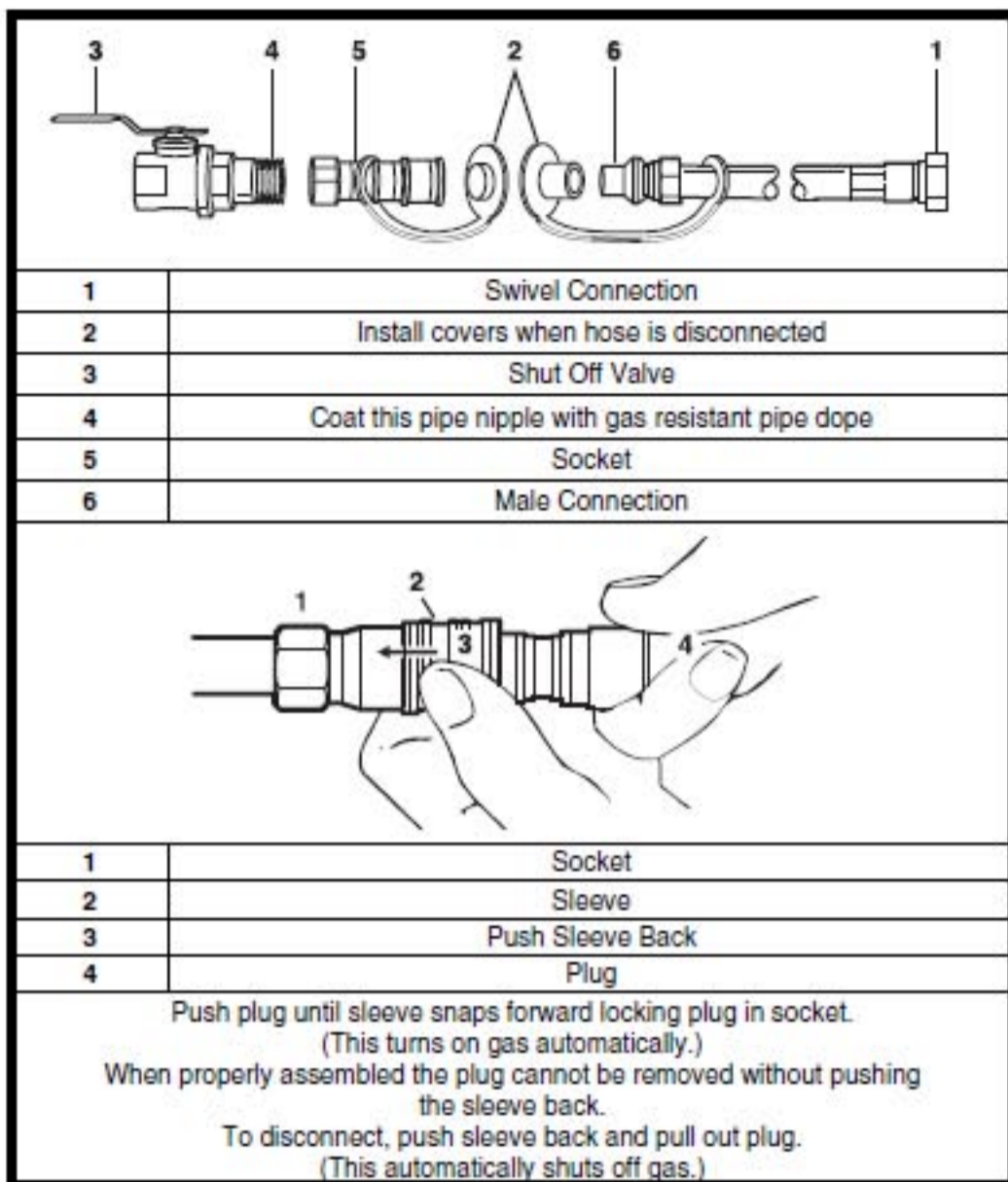

LEAK CHECK PREPARATION

CHECK THAT ALL BURNER VALVES ARE OFF

Valves are shipped in the "OFF" position, but you should check to be sure that they are turned off. Check by pushing in and turning clockwise. If they do not turn, they are off. Proceed to the next step. If they do turn continue turning them clockwise until they stop, then they are off. Proceed to the next step.

REMOVE CONTROL KNOBS & CONTROL PANEL FOR LEAK TESTING

You will need: Phillips screwdriver.

- 1) Take off the burner control knobs.
- 2) Remove screw and washer from back of control panel with a Phillips screwdriver.
- 3) Remove machine screw from lower left and right side of control panel with a Phillips screwdriver.
- 4) Tilt the back edge of the control panel up. Carefully lift control panel up and away from frame.
- 5) Disconnect the igniter wires from the ignition module.
- 6) Replace control panel when Leak Check is completed.

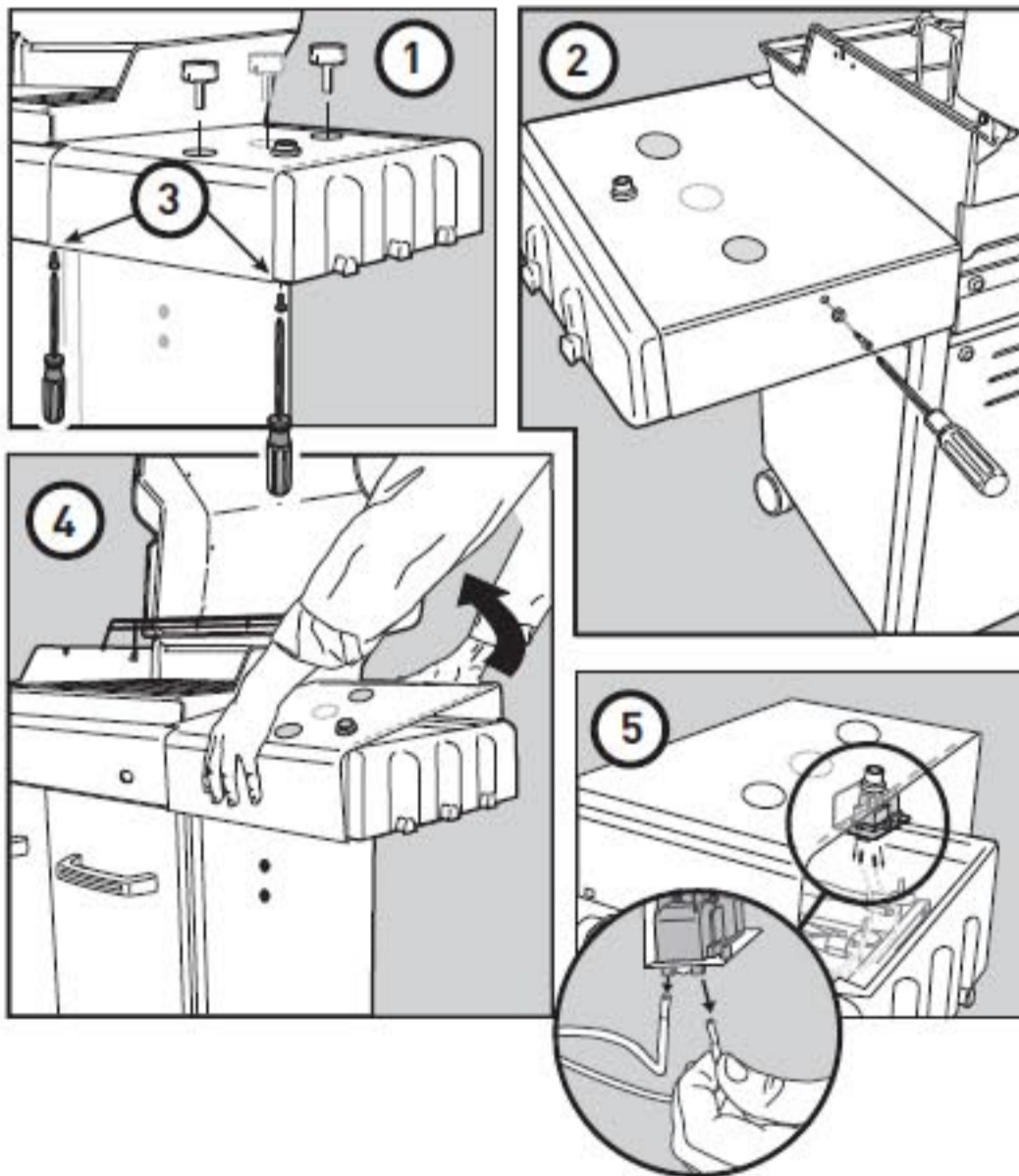

CHECK THE FLEXIBLE HOSE TO MANIFOLD CONNECTION

The natural gas hose has been attached during the manufacturing process. We do recommend that the hose to gas manifold connection be leak tested, following guidelines in this Owner's Guide, prior to barbecue operation.

CHECK FOR GAS LEAKS

⚠ DANGER

Do not use an open flame to check for gas leaks. Be sure there are no sparks or open flames in the area while you check for leaks. Sparks or open flames will result in a fire or explosion which can cause serious bodily injury or death and damage to property.

⚠ WARNING: You should check for gas leaks every time you disconnect and reconnect a gas fitting.

Note: All factory-made connections have been thoroughly checked for gas leaks. The burners have been flame-tested. As a safety precaution however, you should recheck all fittings for leaks before using your Weber® gas barbecue. Shipping and handling may loosen or damage a gas fitting.

⚠ WARNING: Perform these leak checks even if your barbecue was dealer or store assembled.

You will need: a soap and water solution, and a rag or brush to apply it. Make sure side burner is off (See LEAK CHECK PREPARATION). Remove valve control knob and screws. Remove porcelain top. To perform leak checks: Slide back the collar of the quick disconnect (1). Push male fitting of the hose into the quick disconnect, and maintain pressure. Slide the collar closed (2). If it does not engage or lock, repeat procedure. Gas will not flow unless the quick disconnect is properly engaged.

Turn on gas supply. Check for leaks by wetting the connections with the soap and water solution and watching for bubbles. If bubbles form or if a bubble grows, there is a leak.

Note: Since some leak test solutions, including soap and water, may be slightly corrosive, all connections should be rinsed with water after checking for leaks.

⚠ WARNING: Do not ignite burners when leak checking.

CHECK:

1) Hose to manifold connection.

⚠ WARNING: If there is a leak at connection(1), retighten the fitting with a wrench and recheck for leaks with soap and water solution. If a leak persists after retightening the fitting, turn OFF the gas. DO NOT OPERATE THE GRILL. Contact the Customer Service Representative in your area using the contact information on our web site. Log onto www.weber.com®.

2) Hose to quick disconnect connection.
3) Valves to manifold connection.

⚠ WARNING: If there is a leak at connections(2) or(3) turn OFF the gas. DO NOT OPERATE THE GRILL. Contact the Customer Service Representative in your area using the contact information on our web site. Log onto www.weber.com®.

When leak checks are complete, turn gas supply OFF at the source and rinse connections with water.

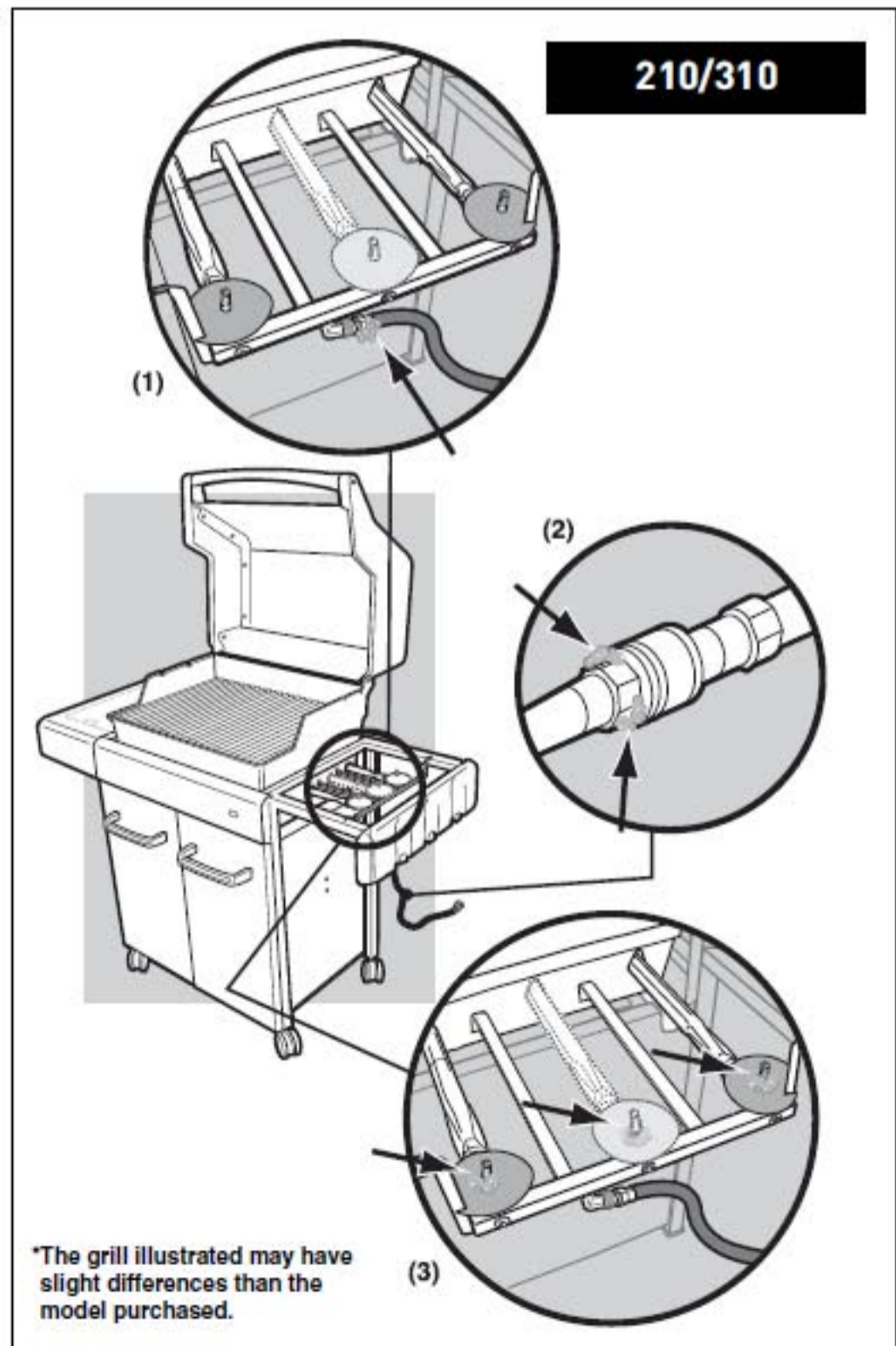
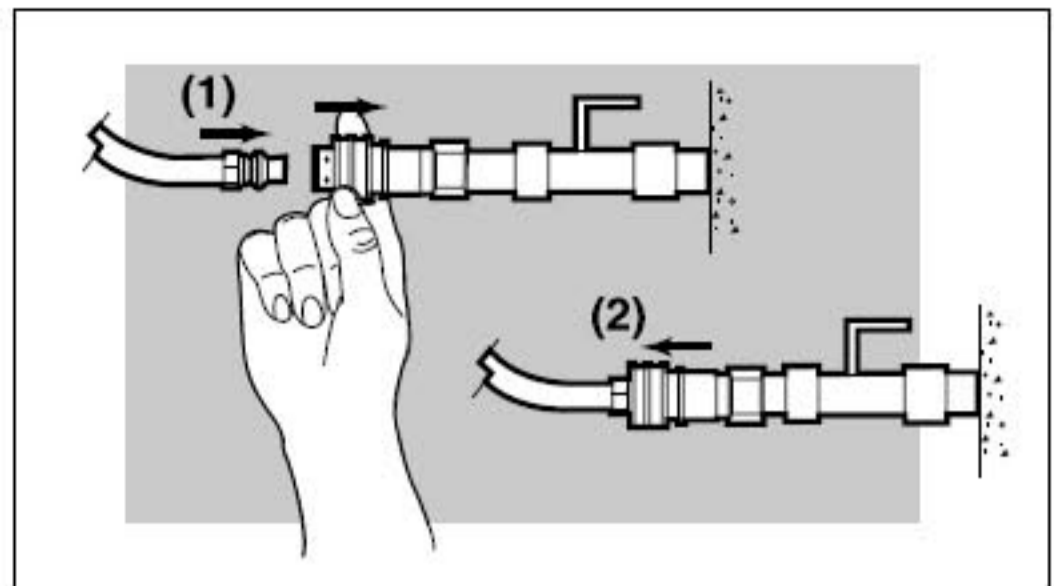

*The grill illustrated may have slight differences than the model purchased.

LIGHTING

Summary lighting instructions are inside the left hand cabinet door.

⚠ DANGER

Failure to open the lid while igniting the barbecue's burners, or not waiting 5 minutes to allow the gas to clear if the barbecue does not light, may result in an explosive flame-up which can cause serious bodily injury or death.

CROSSOVER® IGNITION SYSTEM

Note: The Crossover® Ignition System ignites BURNER 1 with a spark from the igniter electrode inside the Gas Catcher® ignition chamber. You generate the energy for the spark by pushing the electronic ignition button. You will hear it sparking.

⚠ WARNING: Check hose before each use of barbecue for nicks, cracking, abrasions or cuts. If the hose is found to be damaged in any way, do not use the barbecue. Replace using only Weber® authorized replacement hose. Contact the Customer Service Representative in your area using the contact information on our web site. Log onto www.weber.com®.

MAIN BURNER LIGHTING

- 1) Open the lid.
- 2) Make sure all burner control knobs are turned OFF. (Push control knob down and turn clockwise to ensure that it is in the OFF position.)
- 3) Turn the gas supply valve on.

⚠ WARNING: Do not lean over the open barbecue. Keep your face and body at least one foot away from the matchlight hole when lighting the barbecue.

- 4) Push BURNER 1 control knob down and turn to START/HI.
- 5) Push and hold the electronic ignition button. You will hear it sparking.
- 6) Check that the burner is lit by looking through the matchlight hole on the front of the cooking box. You should see a flame.

⚠ WARNING: If the burner does not light in five (5) seconds, turn the Burner 1 control knob to OFF and wait 5 minutes to let the gas clear before you try again or try to light with a match.

- 7) After BURNER 1 is lit you can turn on BURNER 2 (and BURNER 3).
- Note - Always light BURNER 1 first. The other burners ignite from BURNER 1.

TO EXTINGUISH

Push down and turn each burner control knob clockwise to the OFF position. Turn gas supply OFF at the source.

MAIN BURNER LIGHTING

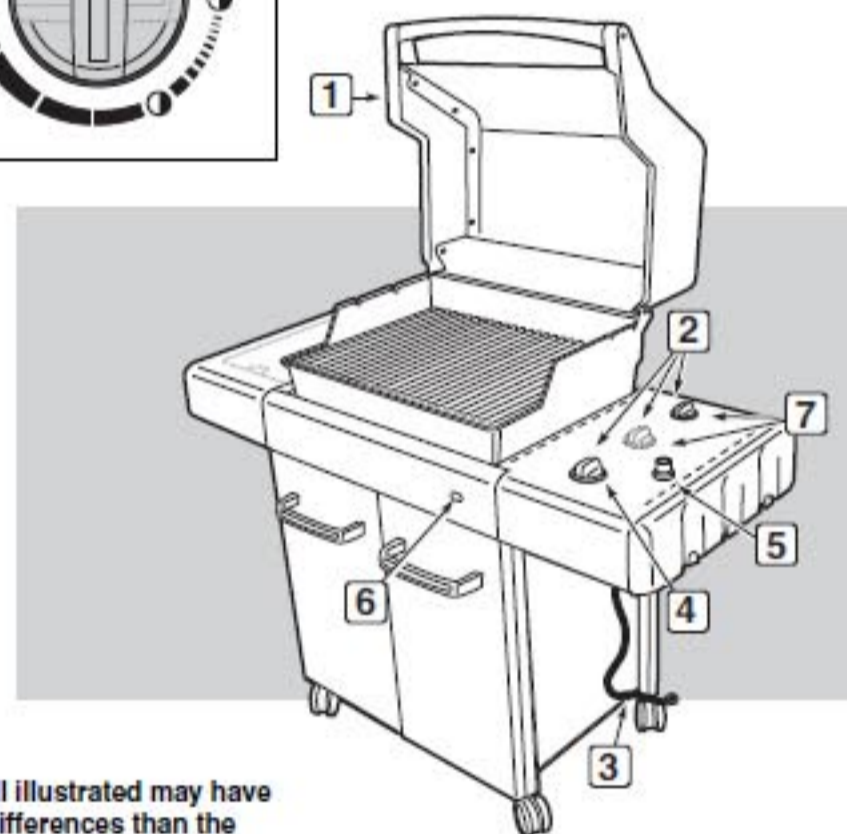
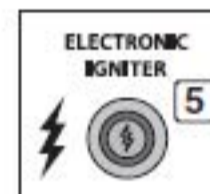
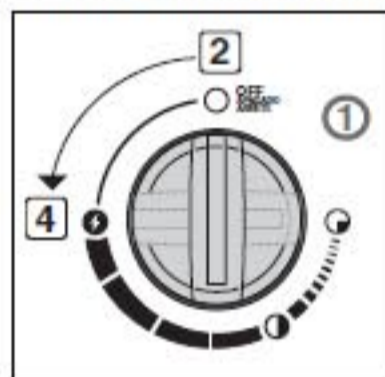

*The grill illustrated may have slight differences than the model purchased.

MAIN BURNER MANUAL LIGHTING

⚠ DANGER

Failure to open the lid while igniting the barbecue's burners, or not waiting 5 minutes to allow the gas to clear if the barbecue does not light, may result in an explosive flame-up which can cause serious bodily injury or death.

- 1) Open the lid.
- 2) Make sure all burner control knobs are turned OFF. (Push each knob down and turn clockwise to ensure they are in the OFF position.)
- 3) Turn the gas supply valve on.
- 4) Insert match holder with lit match into the matchlight hole in the front of the cooking box.

⚠ WARNING: Do not lean over open barbecue. Keep your face and body at least one foot away from the matchlight hole when lighting the barbecue.

- 5) Push BURNER 1 control knob down and turn to START/HI.
- 6) Check that the burner is lit by looking through the matchlight hole on the front of the cooking box. You should see a flame.

⚠ WARNING: If the burner does not light in five seconds, turn the Burner 1 control knob to OFF and wait 5 minutes to let the gas clear before you try again.

- 7) After BURNER 1 is lit you can turn on BURNER 2 (and BURNER 3).
- Note - Always light BURNER 1 first. The other burners ignite from BURNER 1.

TO EXTINGUISH

Push down and turn each burner control knob clockwise to the OFF position. Turn gas supply OFF at the source.

MAIN BURNER MANUAL LIGHTING

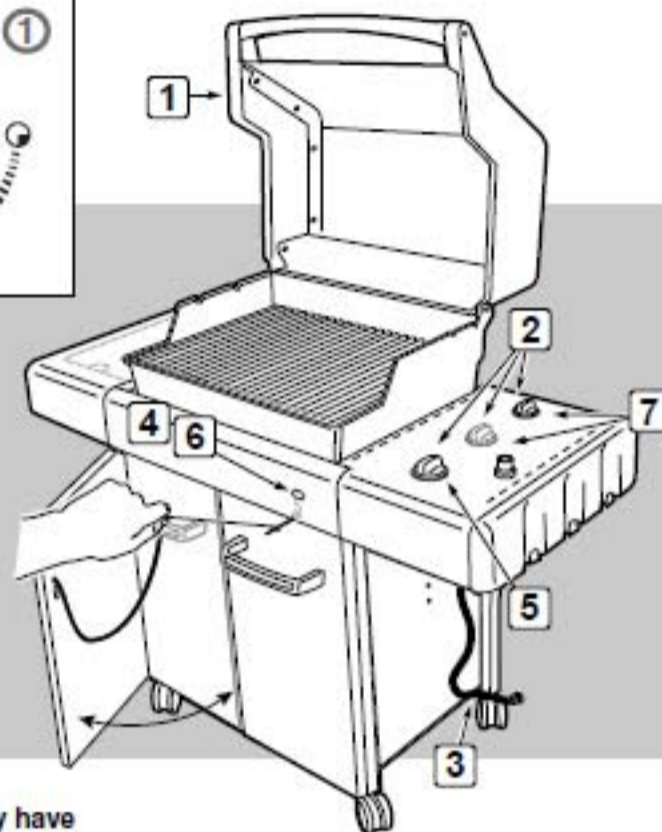
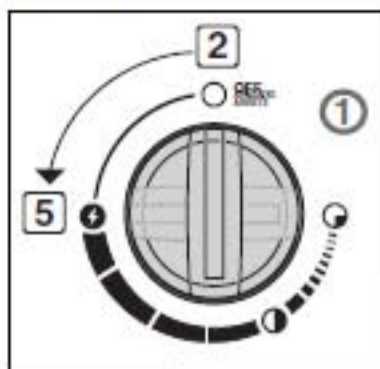

*The grill illustrated may have slight differences than the model purchased.

TROUBLESHOOTING

PROBLEM	CHECK	CURE
Burners burn with a yellow or orange flame, in conjunction with the smell of gas.	Inspect Spider / Insect Screens for possible obstructions. (Blockage of holes.)	Clean Spider / Insect Screens. (See Section "Annual Maintenance")
Burner does not light, or flame is low in "HI" position.	Is fuel hose bent or kinked?	Straighten fuel hose.
	Does the burner light with a match?	If you can light Burner 1 with a match, then check the Crossover® ignition system.
Experiencing flare-ups: ⚠ CAUTION: Do not line the bottom tray with aluminum foil.	Are you preheating barbecue in the prescribed manner?	All burners on "HI" for 10 to 15 minutes for preheating.
	Are the cooking grates and Flavorizer® bars heavily coated with burned-on grease?	Clean thoroughly. (See Section "Cleaning")
	Is the bottom tray "dirty" and not allowing grease to flow into catch pan?	Clean bottom tray.
Burner flame pattern is erratic. Flame is low when burner is on "HI." Flames do not run the whole length of the burner tube.	Are burners clean?	Clean burners. (See Section "Maintenance")
Inside of lid appears to be "peeling." (Resembles paint peeling.)	The lid is porcelain enamel or stainless steel, not paint. It cannot "peel." What you are seeing is baked on grease that has turned to carbon and is flaking off. THIS IS NOT A DEFECT.	Clean thoroughly. (See Section "Cleaning")
Cabinet doors are not aligned.	Check the adjustment pin on the bottom of each door.	Loosen adjustment nut/s. Slide door/s until aligned. Tighten nut.

If problems cannot be corrected by using these methods, please contact the Customer Service Representative in your area using the contact information on our web site. Log onto www.weber.com®.

WEBER® SPIDER/INSECT SCREENS

Your Weber® gas barbecue, as well as any outdoor gas appliance, is a target for spiders and other insects. They can nest in the venturi section (1) of the burner tubes. This blocks the normal gas flow, and can cause the gas to flow back out of the combustion air opening. This could result in a fire in and around the combustion air openings, under the control panel, causing serious damage to your barbecue.

The burner tube combustion air opening is fitted with a stainless steel screen (2) to prevent spiders and other insects access to the burner tubes through the combustion air openings.

We recommend that you inspect the Spider/Insect screens at least once a year. (See Section "Annual Maintenance".) Also inspect and clean the the Spider/Insect screens if any of the following symptoms should ever occur:

- 1) The smell of gas in conjunction with the burner flames appearing yellow and lazy.
- 2) Barbecue does not reach temperature.
- 3) Barbecue heats unevenly.
- 4) One or more of the burners do not ignite.

⚠ DANGER

Failure to correct the above mentioned symptoms may result in a fire, which can cause serious bodily injury or death, and cause damage to property.

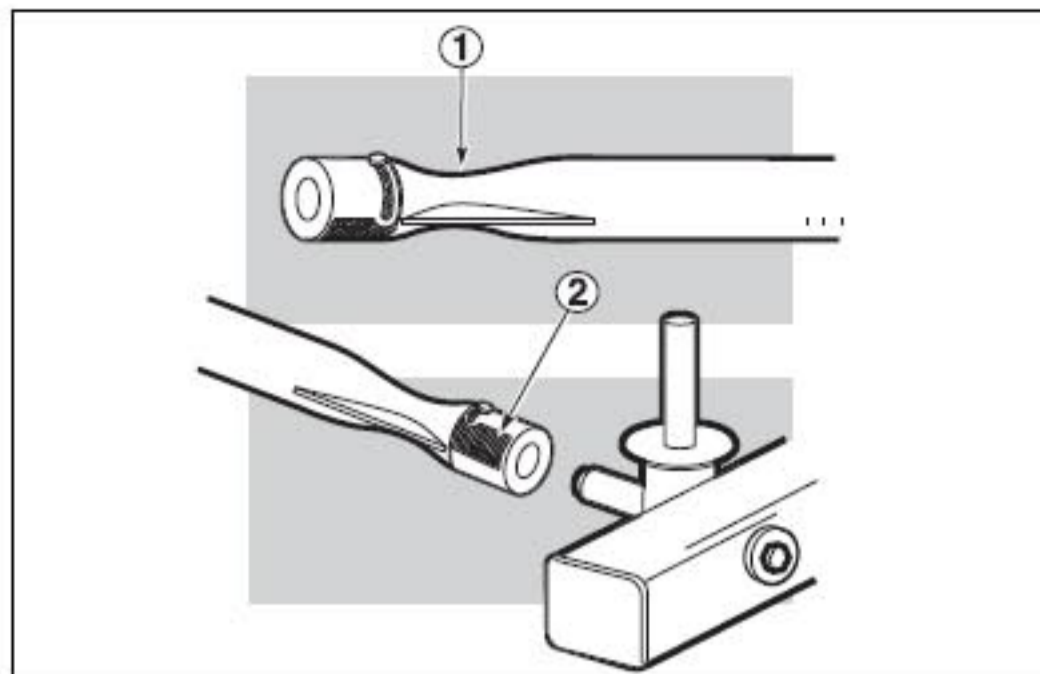

ANNUAL MAINTENANCE

INSPECTION AND CLEANING OF THE SPIDER/INSECT SCREENS

To inspect the Spider/Insect screens, remove the control panel. If there is dust or dirt on the screens, remove the burners for cleaning the screens.

Brush the Spider/Insect screens lightly with a soft bristle brush (i.e. an old toothbrush).

⚠ CAUTION: Do not clean the Spider/Insect screens with hard or sharp tools. Do not dislodge the Spider/Insect screens or enlarge the screen openings.

Lightly tap the burner to get debris and dirt out of the burner tube. Once the Spider/Insect screens and burners are clean replace the burners.

If the Spider/Insect screen becomes damaged or cannot be cleaned, please contact the Customer Service Representative in your area using the contact information on our web site. Log onto www.weber.com®.

BURNER FLAME PATTERN

The Weber® gas barbecue burners have been factory set for the correct air and gas mixture. The correct flame pattern is shown.

- 1) Burner tube
- 2) Tips occasionally flicker yellow
- 3) Light blue
- 4) Dark blue

If the flames do not appear to be uniform throughout the burner tube, follow the burner cleaning procedures.

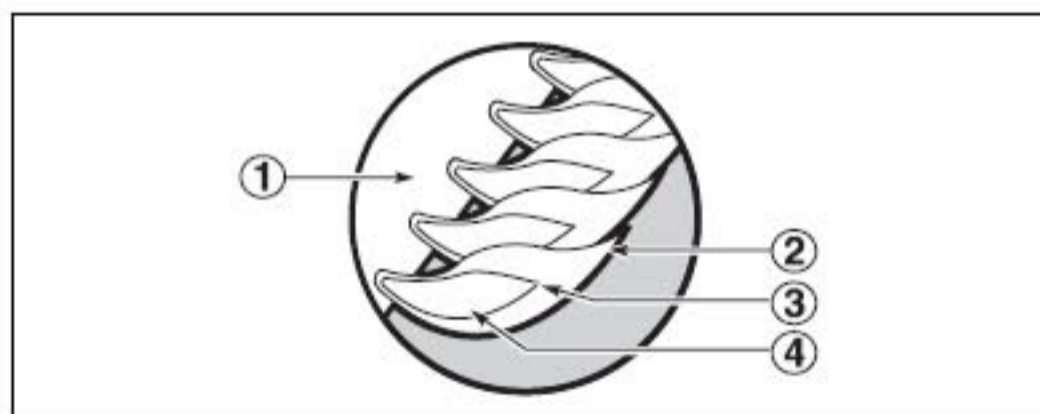

MAIN BURNER CLEANING PROCEDURE

Turn off the gas supply.

Remove the manifold (See "Replacing Main Burners").

Look inside each burner with a flashlight.

Clean the inside of the burners with a wire (a straightened-out coat hanger will work).

Check and clean the air shutter opening at the ends of the burners. Check and clean the valve orifices at the base of the valves. Use a Steel bristle brush to clean outside of burners. This is to make sure all the burner ports are fully open.

⚠ CAUTION: Do not enlarge the burner ports when cleaning.

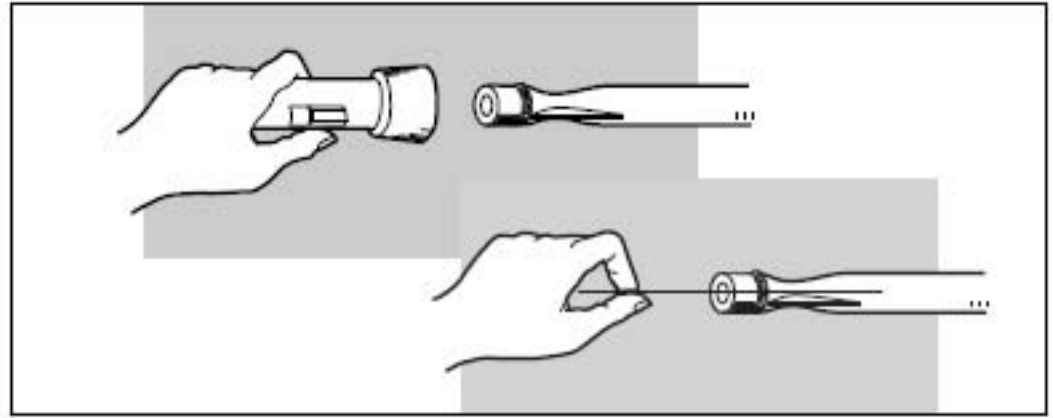

REPLACING MAIN BURNERS

1) Your Weber® gas barbecue must be OFF and cool.

2) Turn gas OFF at source.

3) To remove control panel:

(a) Take off the burner control knobs.

(b) Remove screw and washer from back of control panel with a Phillips screwdriver.

(c) Tilt the back edge of the control panel up. Push in on the front edge to release locking tabs.

(d) Disconnect the igniter wires from the ignition module.

(e) Carefully pull control panel away from frame.

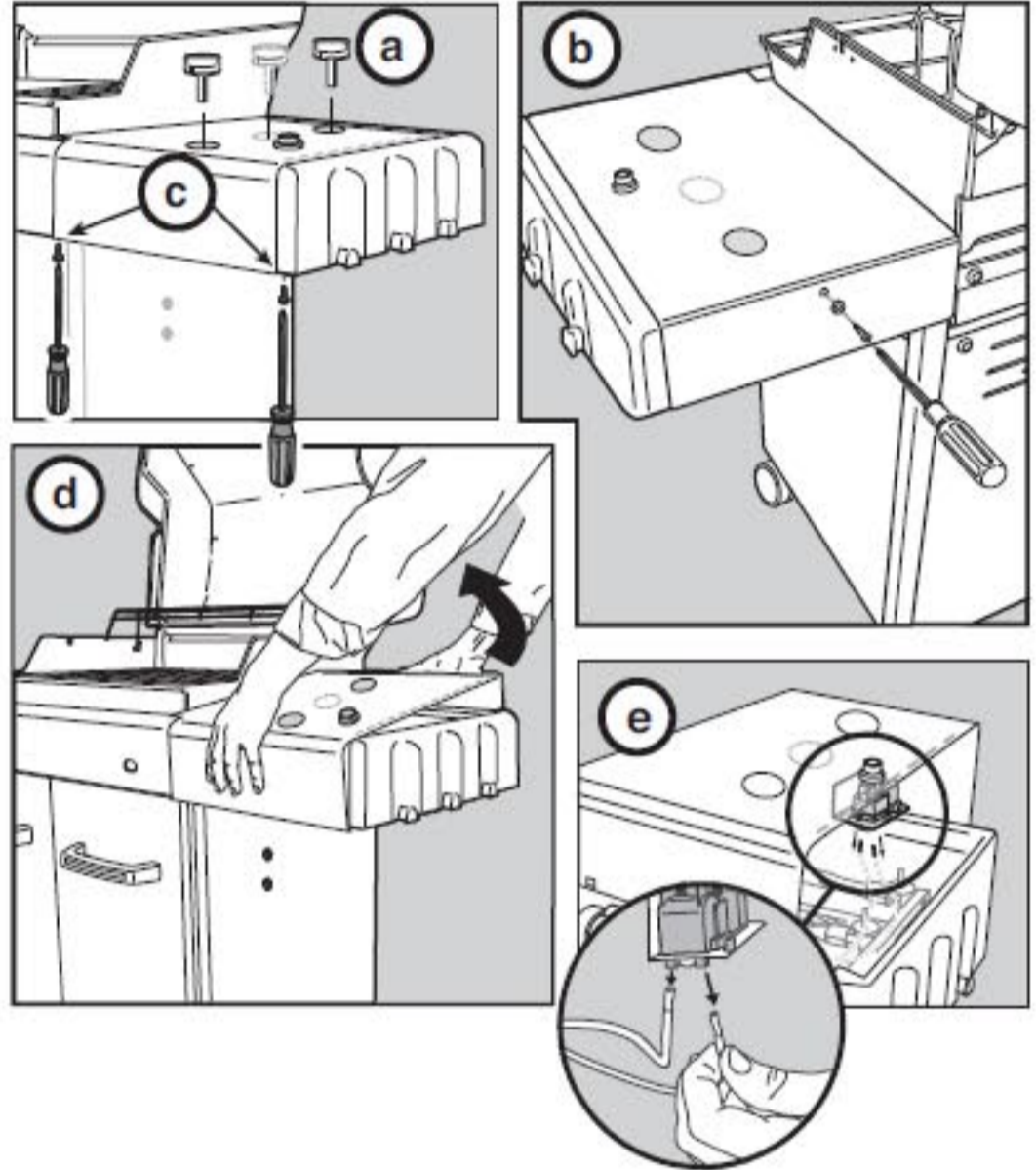

- 4) Remove the two threaded 7/16" hex screws (a) that hold the manifold support bracket to the cooking box. Pull the manifold and valve assembly towards you, at the same time lift the manifold assembly up to release the manifold brackets from the frame assembly. (b).

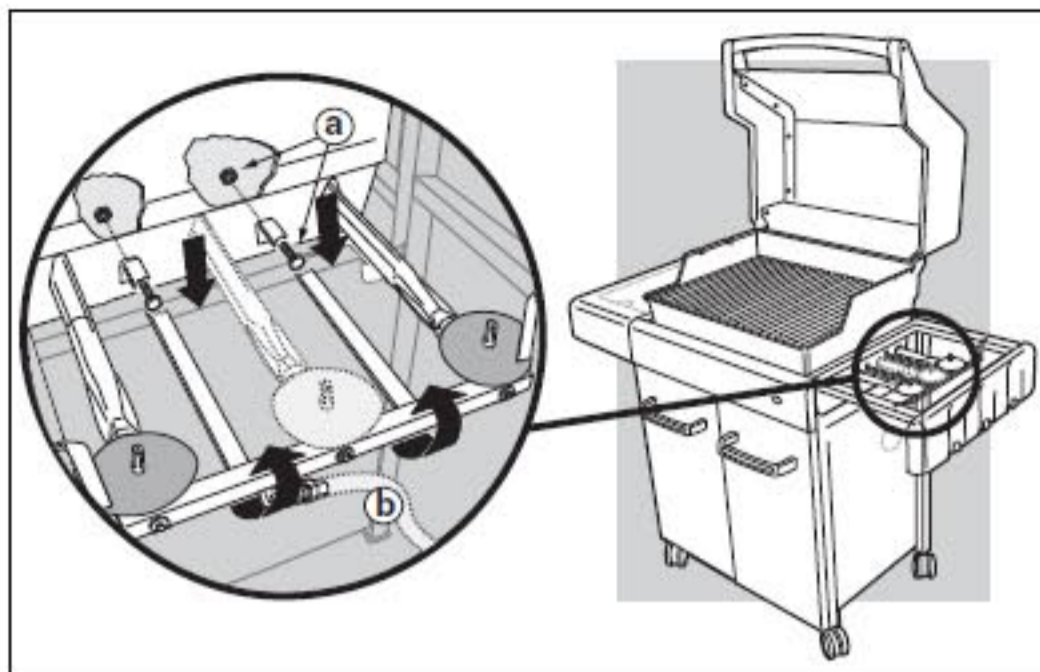

- 5) Slide the burner assembly out from under the guide screw and washer (a) in the corners of the cooking box.
6) Lift and twist the burner assembly slightly, to separate the crossover tube (b) from the burners. Remove the burners from the cooking box.
7) To reinstall the burners, reverse 3) through 7).

⚠ CAUTION: The burner openings (c) must be positioned properly over the valve orifices (d).

Check proper assembly before fastening manifold in place.

⚠ WARNING: After reinstalling the gas lines, they should be leak checked with a soap and water solution before using the barbecue. (See Step: "Check for gas leaks.")

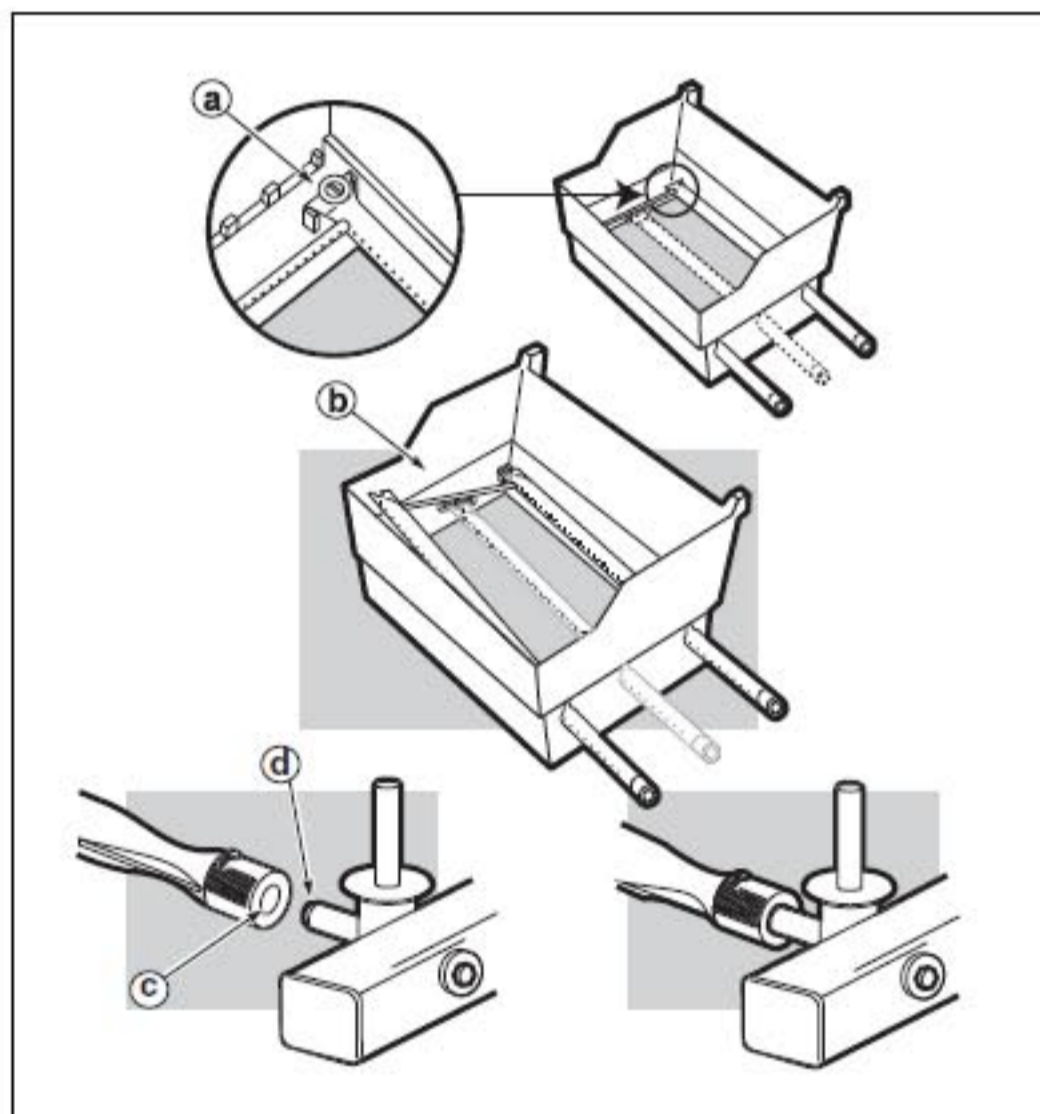

CROSSOVER® IGNITION SYSTEM OPERATIONS

If The Crossover® Ignition System fails to ignite the BURNER 1, light BURNER 1 with a match. If BURNER 1 lights with a match, then check the Electronic Ignition System.

- Check that both of the ignition wires are attached at the igniter module properly.
- Check that the ignition wire is attached at the ceramic igniter properly.
- Check that the ceramic igniter assembly (A) is fully positioned into burner tube 1 igniter channel (B).
- Check that the ceramic igniter is properly positioned over the burner holes on BURNER 1.
- Check that the Electronic Ignition Button is working by listening and looking for sparks at BURNER 1.

REPLACE BATTERY IF NECESSARY

AAA alkaline battery only. See illustration:

If the Electronic Ignition System still fails to light, contact the Customer Service Representative in your area using the contact information on our web site. Log onto www.weber.com®.

