

# SPIRIT®



## GAS GRILL

### LP Gas Grill Owner's Guide

Guía del propietario del asador de gas licuado de propano - Pg 19

Guide de l'utilisateur du grill à gaz PL - Pg 34

E/EP - 320

#89962



**YOU MUST READ THIS OWNER'S GUIDE BEFORE OPERATING YOUR GAS GRILL**

**⚠ DANGER**

If you smell gas:

1. Shut off gas to the appliance.
2. Extinguish any open flames.
3. Open lid.
4. If odor continues, keep away from the appliance and immediately call your gas supplier or your fire department.

Leaking gas may cause a fire or explosion which can cause serious bodily injury or death, or damage to property.

**⚠ WARNING:**

1. Do not store or use gasoline or other flammable liquids or vapors in the vicinity of this or any other appliance.
2. An LP cylinder not connected for use shall not be stored in the vicinity of this or any other appliance.

**⚠ WARNING:** Follow all leak-check procedures carefully in this manual prior to barbecue operation. Do this even if the barbecue was dealer-assembled.

**NOTICE TO INSTALLER:** These instructions must be left with the owner and the owner should keep them for future use.

**THIS GAS APPLIANCE IS DESIGNED FOR OUTDOOR USE ONLY.**

**⚠ WARNING:** Do not try to light this appliance without reading the "Lighting Instructions" section of this manual.



## ⚠ DANGER

Failure to follow the Dangers, Warnings and Cautions contained in this Owner's Manual may result in serious bodily injury or death, or in a fire or an explosion causing damage to property.

## ⚠ WARNINGS

- ⚠ Do not store a spare or disconnected liquid propane cylinder under or near this barbecue.
- ⚠ Improper assembly may be dangerous. Please follow the assembly instructions carefully.
- ⚠ After a period of storage, and/or nonuse, the Weber® gas barbecue should be checked for gas leaks and burner obstructions before use. See instructions in this manual for correct procedures.
- ⚠ Do not operate the Weber® gas barbecue if there is a gas leak present.
- ⚠ Do not use a flame to check for gas leaks.
- ⚠ Combustible materials should never be within 24 inches (61 cm) of the back or sides of your Weber® gas barbecue.
- ⚠ Do not put a barbecue cover or anything flammable on, or in the storage area under the barbecue.
- ⚠ Your Weber® gas barbecue should never be used by children. Accessible parts of the barbecue may be very hot. Keep young children away while it is in use.
- ⚠ You should exercise reasonable care when operating your Weber® gas barbecue. It will be hot during cooking or cleaning and should never be left unattended, or moved while in operation.
- ⚠ Should the burners go out while in operation, turn all gas valves off. Open the lid and wait five minutes before attempting to relight, using the lighting instructions.
- ⚠ Do not use charcoal or lava rock in your Weber® gas barbecue.
- ⚠ Never lean over open grill or place hands or fingers on the front edge of the cooking box.
- ⚠ Should a grease fire occur, turn off all burners and leave lid closed until fire is out.
- ⚠ Do not enlarge valve orifices or burner ports when cleaning the valves or burners.
- ⚠ The Weber® gas barbecue should be thoroughly cleaned on a regular basis.
- ⚠ Liquid propane gas is not natural gas. The conversion or attempted use of natural gas in a liquid propane unit or liquid propane gas in a natural gas unit is dangerous and will void your warranty.
- ⚠ Do not attempt to disconnect any gas fitting while your barbecue is in operation.
- ⚠ Use heat-resistant barbecue mitts or gloves when operating barbecue.
- ⚠ Keep any electrical supply cord and the fuel supply hose away from any heated surfaces.
- ⚠ Combustion byproducts produced when using this product contain chemicals known to the state of California to cause cancer, birth defects, or other reproductive harm.
- ⚠ Do not use this barbecue unless all parts are in place. The unit must be properly assembled according to the assembly instructions.
- ⚠ Do not build this model of grill in any built-in or slide in construction. Ignoring this Warning could cause a fire or an explosion that can damage property and cause serious bodily injury or death.
- ⚠ Proposition 65 Warning: Handling the brass material on this product exposes you to lead, a chemical known to the state of California to cause cancer, birth defects or other reproductive harm.  
(Wash hands after handling this product.)

## LIQUID PROPANE GAS UNITS ONLY:

- ⚠ Use the pressure regulator and hose assembly that is supplied with your Weber® gas barbecue.
- ⚠ Do not attempt to disconnect the gas regulator and hose assembly or any gas fitting while your barbecue is in operation.
- ⚠ A dented or rusty liquid propane cylinder may be hazardous and should be checked by your liquid propane supplier. Do not use a liquid propane cylinder with a damaged valve.
- ⚠ Although your liquid propane cylinder may appear to be empty, gas may still be present, and the cylinder should be transported and stored accordingly.
- ⚠ If you see, smell or hear the hiss of escaping gas from the liquid propane cylinder:
  1. Move away from liquid propane cylinder.
  2. Do not attempt to correct the problem yourself.
  3. Call your fire department.

Weber-Stephen Products Co. (Weber) hereby warrants to the ORIGINAL PURCHASER of this Weber® gas grill that it will be free of defects in material and workmanship from the date of purchase as follows:

Aluminum castings	25-years (2 years on paint; excludes fading)
Stainless steel Shroud	25-years
Porcelain-enamelled shroud	25-years
Cookbox Assembly	10-years (2 year on paint excludes fading)
Stainless steel burners tubes	10-years
Stainless steel cooking grates	5-years no rust through or burn through
Stainless steel Flavorizer bars	5-years no rust through or burn through
Porcelain-enamelled cast-iron cooking grates	5-year no rust through or burn through
Porcelain-enamelled cooking grates	3-years no rust through or burn through
Porcelain-enamelled Flavorizer bars	2-years no rust through or burn through
Infrared Rotisserie Burner	2-years
All remaining parts	2-years

When assembled and operated in accordance with the printed instructions accompanying it. Weber may require reasonable proof of your date of purchase. THEREFORE, YOU SHOULD RETAIN YOUR SALES SLIP OR INVOICE.

This Limited Warranty shall be limited to the repair or replacement of parts that prove defective under normal use and service and which on examination shall indicate, to Weber's satisfaction, they are defective. Before returning any parts, contact the Customer Service Representative in your area using the contact information on our website. If Weber confirms the defect and approves the claim, Weber will elect to replace such parts without charge. If you are required to return defective parts, transportation charges must be prepaid. Weber will return parts to the purchaser, freight or postage prepaid.

This Limited Warranty does not cover any failures or operating difficulties due to accident, abuse, misuse, alteration, misapplication, vandalism, improper installation or improper maintenance or

Weber-Stephen Products Co., (Weber) mediante la presente le garantiza al COMPRADOR ORIGINAL de esta barbacoa de gas Weber® que la misma estará libre de defectos en cuanto a materiales y fabricación a partir de la fecha de compra según lo siguiente:

Piezas coladas de aluminio	25-años (2 años para la pintura excluyendo la decoloración)
Cubierta de acero inoxidable	25-años
Cubierta porcelanizada	25-años
Cámara para asar	10-años (2 años para la pintura excluyendo la decoloración)
Tubos de acero inoxidable de los quemadores	10-años
Parrillas de cocción de acero inoxidable	5-años sin perforación por fuego u oxidación
Baras Flavorizer de acero inoxidable	5-años sin perforación por fuego u oxidación
Parrillas de cocción de hierro colado porcelanizado	5-años sin perforación por fuego u oxidación
Parrillas de cocción porcelanizadas	3-años sin perforación por fuego u oxidación
Baras Flavorizer porcelanizadas	2-años sin perforación por fuego u oxidación
Quemador infrarrojo del asador giratorio	2-años
Todas las demás partes	2-años

cuando se ensambla y opera de acuerdo a las instrucciones impresas que la acompañan. Weber pudiere requerir prueba razonable de la fecha de compra. POR LO TANTO, DEBERÁ GUARDAR SU RECIBO O FACTURA DE VENTA.

Esta garantía limitada está limitada a la reparación o reemplazo de piezas que resultasen defectuosas bajo uso y servicio normal y las cuales al examinarse indiquen, a plena satisfacción de Weber, que efectivamente son piezas defectuosas. Antes de devolver cualquier parte, contacte al Representante de Atención al Cliente en su área, cuya información de contacto la encontrará en nuestro sitio web. Si Weber confirma el defecto y aprueba el reclamo, ésta elegirá reparar o reemplazar tal pieza sin cargo alguno. Si usted tiene que retornarnos las partes defectuosas, los gastos de transporte deben ser prepagados. Weber retornará las partes al comprador con transporte o franqueo prepagado. Esta Garantía Limitada no cubre ninguna falla o problema de operación a causa de accidentes, abuso, mal uso, alteración, uso en aplicaciones indebidas, vandalismo, instalación inapropiada o mantenimiento o servicio inapropiados, o por no llevar a cabo el mantenimiento normal y rutinario,

Weber-Stephen Products Co. (Weber) garantit par le présent document à l'ACHETEUR D'ORIGINE de ce grill à gaz Weber® que celui-ci ne comportera aucun défaut de pièce ni de main d'oeuvre à compter de la date d'achat comme suit :

Forte d'aluminium	25 ans (2 ans pour la peinture à l'exception de toute décoloration)
Structure en acier inoxydable	25 ans
Structure émaillée	25 ans
Cuve	10 ans (2 ans pour la peinture à l'exception de toute décoloration)
Tubes du brûleur en acier inoxydable	10 ans
Grilles de cuisson en acier inoxydable	5 ans sans trou provoqué par la rouille ou par une brûlure
Baras Flavorizer en acier inoxydable	5 ans sans trou provoqué par la rouille ou par une brûlure
Grilles de cuisson en fonte fer émaillée	5 ans sans trou provoqué par la rouille ou par une brûlure
Grilles de cuisson émaillées	3 ans sans trou provoqué par la rouille ou par une brûlure
Baras Flavorizer émaillées	2 ans sans trou provoqué par la rouille ou par une brûlure
Brûleur de la rôtissoire à infrarouge	2 ans
Toutes les autres pièces	2 ans

à condition qu'il ait été assemblé et utilisé conformément aux instructions imprimées qui l'accompagnent.

Weber peut exiger une preuve raisonnable de votre date d'achat. VOUS DEVRIEZ DONC CONSERVER VOTRE TICKET DE CAISSE OU VOTRE FACTURE.

La présente Garantie limitée est limitée à la réparation ou au remplacement des pièces qui s'avèrent défectueuses dans le cadre d'une utilisation normale et d'un entretien normal et dont l'examen indique, à la satisfaction de Weber, qu'elles sont défectueuses. Avant de retourner toute pièce, veuillez entrer en contact avec le Représentant du Service clientèle le plus proche grâce aux coordonnées à votre disposition sur notre site Internet. Si Weber confirme le défaut et approuve la demande, Weber choisira de remplacer ces pièces sans frais. S'il vous est demandé de retourner les pièces défectueuses, les frais de transport devront être prépayés. Weber retournera les pièces à l'acheteur, franco de port.

La présente Garantie limitée ne couvre pas toute défaillance ou difficulté d'utilisation provoquée par un accident, une utilisation abusive, une mauvaise utilisation, une altération, une mauvaise application, un acte de vandalisme, une installation incorrecte ou une maintenance ou un entretien incorrects, ou le

service, or failure to perform normal and routine maintenance, including but not limited to damage caused by insects within the burner tubes, as set out in this owner's manual. Deterioration or damage due to severe weather conditions such as hail, hurricanes, earthquakes or tornadoes, discoloration due to exposure to chemicals either directly or in the atmosphere, is not covered by this Limited Warranty.

There are no other express warrants except as set forth herein and any applicable implied warranties of merchantability and fitness are limited in duration to the period of coverage of this express written Limited Warranty. Some regions do not allow limitation on how long an implied warranty lasts, so this limitation may not apply to you.

Weber is not liable for any special, indirect or consequential damages. Some regions do not allow the exclusion or limitation of incidental or consequential damages, so this limitation or exclusion may not apply to you.

Weber does not authorize any person or company to assume for it any other obligation or liability in connection with the sale, installation, use, removal, return, or replacement of its equipment; and no such representations are binding on Weber.

This Warranty applies only to products sold at retail.

**WEBER-STEPHEN PRODUCTS CO.**

Customer Service Center  
1890 Roselle Road, Suite 308  
Schaumburg, IL 60195  
USA

For replacement parts call:  
1-800-446-1071  
www.weber.com®

entre los que se incluyen, pero sin limitación, los daños causados por insectos dentro de los tubos quemadores, según se detalla en este manual del propietario.

Esta Garantía Limitada no cubre el deterioro o daños a causa de condiciones de tiempo inclemente tales como granizo, huracanes, terremotos o tornados ni tampoco la decoloración por exposición a sustancias químicas bien sea por contacto directo o por que las mismas contenidas en la atmósfera.

No existe ninguna otra garantía expresa que no sean las acá indicadas y cualesquier garantías implícitas de comerciabilidad y aptitud de uso están limitadas en duración al tiempo de cobertura de esta expresa Garantía Limitada por escrito. Algunas regiones no permiten limitación alguna en el tiempo que una garantía implícita pueda durar, por lo que esta limitación pudiera no aplicarle a usted. Weber no se hace responsable de cualesquier daños especiales, indirectos o emergentes. Algunas regiones no permiten la exclusión o limitación de daños incidentales o emergentes, por lo que esta limitación o exclusión pudieran no aplicarle a usted.

Weber no autoriza a persona o empresa alguna a asumir en su nombre ninguna obligación o responsabilidad en relación con la venta, instalación, uso, retiro, devolución o reemplazo de sus equipos, y ninguna tal representación será vinculante para Weber.

Esta Garantía aplica solo a aquellos productos vendidos al por menor.

**WEBER-STEPHEN PRODUCTS CO.**

Customer Service Center  
1890 Roselle Road, Suite 308  
Schaumburg, IL 60195  
USA

Para partes de repuesto llame a:  
1-800-446-1071  
www.weber.com®

Para compras hechas en México  
**WEBER-STEPHEN PRODUCTS S.A. de C.V.**  
Marcella No. 338,  
Colonia Americana  
44160 México, C.P.  
México

Para partes de repuesto llame a:  
(52) (33) 3615-0736  
www.weber.com®

défaut d'entretien normal et régulier, y compris mais pas seulement les dommages provoqués par des insectes à l'intérieur des tubes du brûleur, tel que décrit dans le présent mode d'emploi.

Toute détérioration ou tout dommage résultant de conditions météorologiques graves comme de la grêle, des ouragans, des séismes ou des tornades, toute décoloration résultant d'une exposition à des agents chimiques directement ou dans l'atmosphère, n'est pas couverte dans le cadre de la présente Garantie limitée.

Il n'existe aucune autre garantie expresse hormis celles exposées dans le présent document et toute garantie de commercialisation et de bon état induite est limitée en durée à la période de couverture de la présente Garantie limitée écrite expresse. Certaines régions n'autorisent pas de limitation de durée de la garantie induite ; il est donc possible que cette limitation ne s'applique pas à vous.

Weber ne peut être tenu pour responsable de tout dommage particulier, induit ou se produisant par voie de conséquence. Certaines régions n'autorisent pas l'exclusion ou la limitation des dommages indirects ou se produisant par voie de conséquence ; il est donc possible que cette limitation ou exclusion ne s'applique pas à vous.

Weber n'autorise aucune personne ou société à présumer en son nom de toute autre obligation ou responsabilité en relation avec la vente, l'installation, l'utilisation, le retrait, le retour ou le remplacement de ses équipements ; et aucune de ces représentations ne lie Weber.

La présente Garantie s'applique uniquement aux produits vendus au détail.

**WEBER-STEPHEN PRODUCTS CO.**

Product Registration  
P.O. Box 40530  
Burlington, ON L7P 4W1

Pour des pièces de rechange, appelez le :

1-800-265-2150  
www.weber.com®

## VISION ÉCLATÉE, DIAGRAMA DE DESPIECE

Spirit\_320\_LP\_US\_09

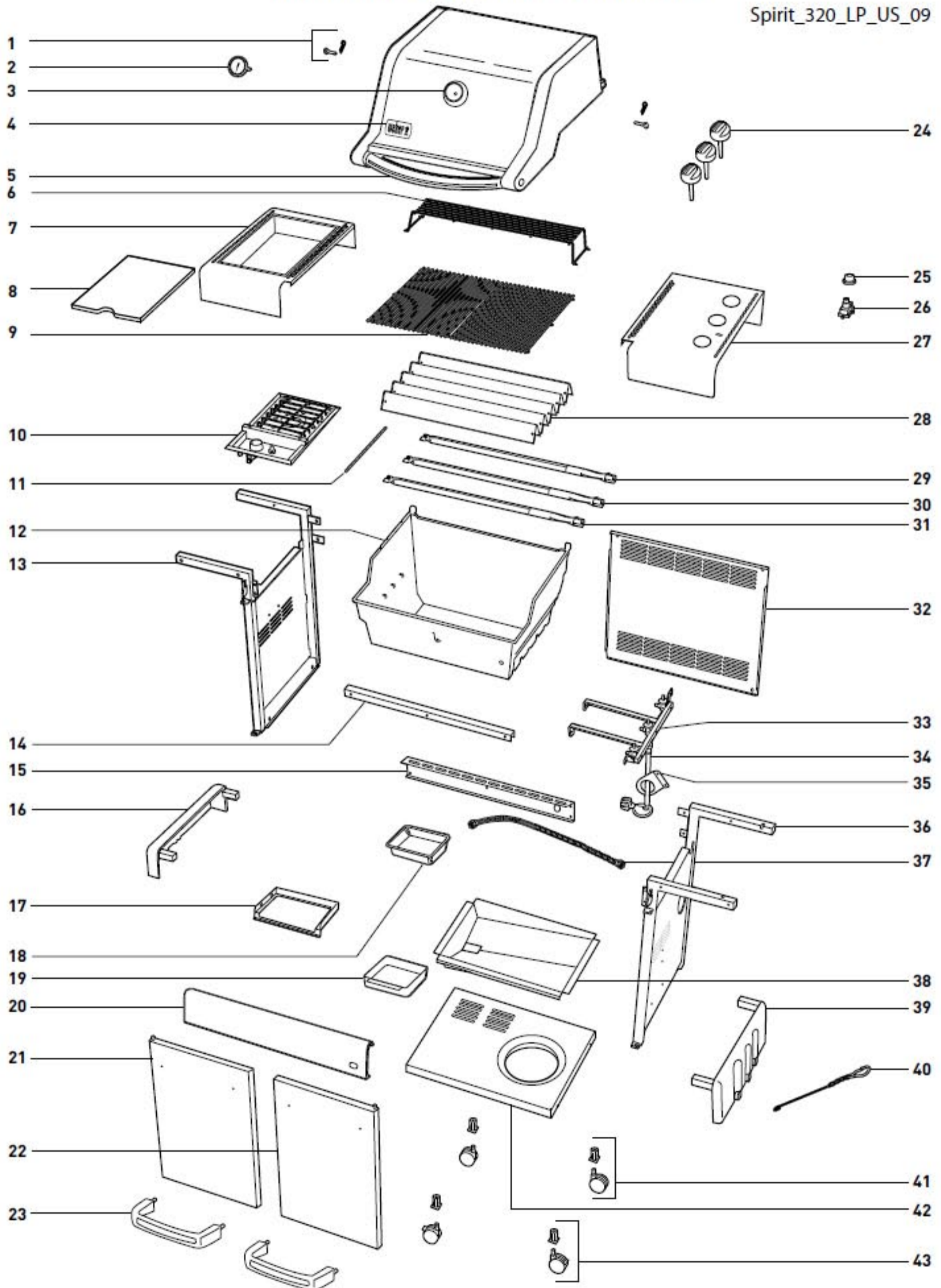

## LISTA DEL DIAGRAMA DE DESPIECE, LISTE DE LA VISION ÉCLATÉE

- |   |  |  |
|---|--|--|
| 1. <b>Shroud Hardware</b><br>Accesorios de la cubierta<br>Kit d'assemblage de boîtier       | 18. <b>Disposable Drip Pan</b><br>Bandeja de goteo desechable<br>Lèchefrite jetable  | 35. <b>Hose Retention Bracket</b><br>Ménsula de retención de la manguera<br>Support de fixation de tuyau |
| 2. <b>Thermometer</b><br>Termómetro<br>Thermomètre  | 19. <b>Catch Pan</b><br>Plato recolector<br>Lèchefrite                               | 36. <b>Right Frame Panel</b><br>Panel derecho del bastidor<br>Panneau de cadre droit                     |
| 3. <b>Thermometer Bezel</b><br>Moldura decorativa del termómetro<br>Cadran de thermomètre   | 20. <b>Front Panel</b><br>Panel frontal<br>Panneau avant                             | 37. <b>Manifold Hose</b><br>Manguera del múltiple<br>Tuyau de collecteur                                 |
| 4. <b>Shroud</b><br>Cubierta<br>Boîtier   | 21. <b>Left Door</b><br>Puerta izquierda<br>Porte gauche                             | 38. <b>Drip Tray</b><br>Bandeja de goteo<br>Bac d'égouttage  |
| 5. <b>Handle</b><br>Asa<br>Poignée  | 22. <b>Right Door</b><br>Puerta derecha<br>Porte droite                              | 39. <b>Right Trim Piece</b><br>Pieza de adorno derecha<br>Élément de décoration droit                    |
| 6. <b>Warming Rack</b><br>Rejilla de calentamiento<br>Grille réchaud                        | 23. <b>Door Handle</b><br>Asa de la puerta<br>Poignée de porte                       | 40. <b>Matchstick Holder</b><br>Portacerillos<br>Porte-allumettes  |
| 7. <b>Side Burner Table</b><br>Mesa del quemador lateral<br>Tablette de brûleur latéral     | 24. <b>Control Knob</b><br>Perilla de control<br>Bouton de commande                  | 41. <b>Caster</b><br>Rueda giratoria<br>Roulette   |
| 8. <b>Side Burner Lid</b><br>Tapa del quemador lateral<br>Couvercle brûleur latéral         | 25. <b>Igniter Button</b><br>Botón de encendido<br>Bouton d'allumage                 | 42. <b>Bottom Panel</b><br>Panel inferior<br>Panneau inférieur   |
| 9. <b>Cooking Grates</b><br>Parrillas de cocción<br>Grilles de cuisson                      | 26. <b>Igniter Module</b><br>Módulo de encendido<br>Module d'allumeur                | 43. <b>Locking Caster</b><br>Rueda giratoria con bloqueo<br>Roulette à frein                             |
| 10. <b>Side Burner</b><br>Quemador lateral<br>Brûleur latéral                               | 27. <b>Right Side Table</b><br>Mesa lateral derecha<br>Tablette latérale droite      |  |
| 11. <b>Crossover Tube</b><br>Tubo Crossover<br>Tube Crossover                               | 28. <b>Flavorizer® Bar</b><br>Barra Flavorizer®<br>Barre de vaporisation Flavorizer® |  |
| 12. <b>Cookbox</b><br>Caja de cocción<br>Cuve   | 29. <b>Rear Burner Tube</b><br>Tubo quemador posterior<br>Tuyau du brûleur arrière   |  |
| 13. <b>Left Frame Panel</b><br>Panel izquierdo del bastidor<br>Panneau de cadre gauche      | 30. <b>Middle Burner Tube</b><br>Tubo quemador del medio<br>Tuyau de brûleur central |  |
| 14. <b>Rear Frame Support</b><br>Soporte posterior del bastidor<br>Panneau de cadre arrière | 31. <b>Front Burner Tube</b><br>Tubo quemador frontal<br>Tuyau de brûleur avant      |  |
| 15. <b>Front Frame Support</b><br>Soporte delantero del bastidor<br>Panneau de cadre avant  | 32. <b>Back Panel</b><br>Panel trasero<br>Panneau arrière                            |  |
| 16. <b>Left Trim Piece</b><br>Pieza de adorno izquierda<br>Élément de décoration gauche     | 33. <b>Manifold</b><br>Múltiple<br>Collecteur  |  |
| 17. <b>Catch Pan Holder</b><br>Soporte del plato recolector<br>Support de lèchefrite        | 34. <b>Hose / Regulator</b><br>Manguera / Regulador<br>Tuyau/ Régulateur             |  |

Your Weber® gas barbecue is a portable outdoor cooking appliance. With the Weber® gas barbecue you can grill, barbecue, roast and bake with results that are difficult to duplicate with indoor kitchen appliances. The closed lid and Flavorizer® Bars produce that “outdoor” flavor in the food.

The Weber® gas barbecue is portable so you can easily change its location in your yard or on your patio. Portability means you can take your Weber® gas barbecue with, if you move.

Liquid Propane (LP) gas supply is easy to use and gives you more cooking control than charcoal fuel.

- These instructions will give you the minimum requirements for assembling your Weber® gas barbecue. Please read the instructions carefully before using your Weber® gas barbecue. Improper assembly can be dangerous.
- Not for use by children.
- If there are local codes that apply to portable gas grills, you will have to conform to them. Installation must conform with local codes or, in the absence of local codes, with either the National Fuel Gas Code, ANSI Z223.1/NFPA 54, Natural Gas and Propane Installation Code, CSA B149.1, or Propane Storage and Handling Code, B149.2, or the Standard for Recreational Vehicles, ANSI A 119.2/NFPA 1192, and CSA Z240 RV Series, Recreational Vehicle Code, as applicable.
- The pressure regulator supplied with the Weber® gas barbecue must be used. This regulator is set for 11 inches of water column (pressure).
- This Weber® gas barbecue is designed for use with liquid propane (LP) gas only. Do not use with natural (piped in city) gas. The valves, orifices, hose and regulator are for LP gas only.
- Do not use with charcoal fuel.
- Check that the area under the control panel and the bottom tray are free from debris that might obstruct the flow of combustion or ventilation air.
- The areas around the LP cylinder must be free and clear from debris.
- Replacement pressure regulators and hose assemblies must be those specified by Weber-Stephen Products Co.

#### FOR INSTALLATION IN CANADA

These instructions, while generally acceptable, do not necessarily comply with the Canadian Installation codes, particularly with piping above and below ground. In Canada the installation of this appliance must comply with local codes and/or Standard CSA-B149.2 (Propane Storage and Handling Code).

#### OPERATING

- ⚠ **WARNING: Only use this barbecue outdoors in a well-ventilated area. Do not use in a garage, building, breezeway or any other enclosed area.**
- ⚠ **WARNING: Keep ventilation openings for cylinder enclosure free and clear from debris.**

#### COOKING

- ⚠ **WARNING: Do not move the Weber® gas barbecue when operating or while barbecue is hot.**

You can adjust BURNER 1, 2, and 3 as desired. The control settings: High (H), Medium (M), Low (L), or Off (O) are described in your Weber® cookbook. The cookbook uses these notations to describe the settings of BURNER 1, 2, and 3. For example, to sear steaks, you would set all burners at H (high). Then to complete cooking, you would set BURNER 1 and BURNER 3 at M (medium). Refer to your Weber® cookbook for detailed cooking instructions.

*Note: The temperature inside your cooking box for the first few uses, while surfaces are still very reflective, may be hotter than those shown in your cookbook. Cooking conditions such as wind and weather, may require the adjustment of the burner controls to obtain the correct cooking temperatures.*

**Preheating** - Your Weber® gas barbecue is an energy-efficient appliance. It operates at an economical low BTU rate. To preheat: after lighting, close lid and turn all burners to high (H). Preheating to between 500° and 550° F (260° and 290° C) will take 10 to 15 minutes depending on conditions such as air temperature and wind.

**Drippings and grease** - The Flavorizer® bars are designed to “smoke” the correct amount of drippings for flavorful cooking. Excess drippings and grease will accumulate in the catch pan under the slide out bottom tray. Disposable foil drip pans are available that fit the catch pan.

- ⚠ **WARNING: Your Weber® gas barbecue shall not be used under overhead combustible construction.**
- ⚠ **WARNING: Your Weber® gas barbecue is not intended to be installed in or on recreational vehicles and/or boats.**
- ⚠ **WARNING: Do not use the barbecue within 24 inches of combustible materials to the back or sides of the grill.**
- ⚠ **WARNING: The entire cooking box gets hot when in use. Do not leave unattended.**
- ⚠ **WARNING: Keep any electrical supply cord and the fuel supply hose away from any heated surface.**
- ⚠ **WARNING: Keep the cooking area clear of flammable vapors and liquids such as gasoline, alcohol, etc., and combustible materials.**
- ⚠ **WARNING: Never store an extra (spare) LP cylinder under or near the Weber® gas barbecue.**
- ⚠ **WARNING: The LP cylinder used with your barbecue must be with a listed OPD (Overfilling Prevention Device) and a QCC1 or Type 1 (CGA810) cylinder connection. The cylinder connection must be compatible with the barbecue connection.**

#### STORAGE AND/OR NONUSE

- The gas must be turned off at the liquid propane cylinder when the Weber® gas barbecue is not in use.
- When the Weber® gas barbecue is stored indoors, the gas supply must be DISCONNECTED and the LP cylinder stored outdoors in a well-ventilated space.
- LP cylinder must be stored outdoors in a well-ventilated area out of reach of children. Disconnected LP cylinder must not be stored in a building, garage or any other enclosed area.
- When the LP cylinder is not disconnected from the Weber® gas barbecue, the appliance and LP tank must be kept outdoors in a well-ventilated space.
- The Weber® gas barbecue should be checked for gas leaks and any obstructions in the burner tubes before using. (See Section: “Maintenance/Annual Maintenance”).
- Check that the areas under the control panel and the slide out bottom tray are free from debris that might obstruct the flow of combustion or ventilation air.
- The Spider /Insect Screens should also be checked for any obstructions. (See Section: “Maintenance/Annual Maintenance”).

- ⚠ **WARNING: Check the bottom tray for grease build-up before each use. Remove excess grease to avoid a grease fire in the slide out bottom tray.**

#### CLEANING

- ⚠ **WARNING: Turn your Weber® gas barbecue off and wait for it to cool before cleaning.**
- ⚠ **CAUTION: Do not clean your Flavorizer® bars or cooking grates in a self-cleaning oven.**

For availability of replacement cooking grates and Flavorizer® bars contact the Customer Service Representative in your area using the contact information on our website. Log onto [www.weber.com](http://www.weber.com)

**Outside surfaces** - Use a warm soapy water solution to clean, then rinse with water.

- ⚠ **CAUTION: Do not use oven cleaner, abrasive cleansers (kitchen cleansers), cleaners that contain citrus products, or abrasive cleaning pads on barbecue or cart surfaces.**

**Slide out Bottom tray** - Remove excess grease, then wash with warm soapy water, then rinse.

**Flavorizer® bars and Cooking grates** - Clean with a suitable brass bristle brush. As needed, remove from grill and wash with warm soapy water, then rinse with water.

**Catch pan** - Disposable foil trays are available, or you can line the catch pan with aluminum foil. To clean the catch pan, wash with warm soapy water, then rinse.

**Thermometer** - Wipe with warm soapy water; clean with plastic scrub ball.

**Inside cooking module** - Brush any debris off of burner tubes. **DO NOT ENLARGE BURNER PORTS (OPENINGS)**. Wash inside of cooking box with warm soapy water and a water rinse.

**Inside Lid** - While lid is warm, wipe inside with paper towel to prevent grease build-up. Flaking built-up grease resembles paint flakes.

**Stainless steel surfaces** - Wash with a soft cloth and a soap and water solution. Be careful to scrub with the grain direction of the stainless steel.

**Do not use cleaners that contain acid, mineral spirits or xylene.** Rinse well after cleaning.

**Preserve Your Stainless Steel** - Your grill or its cabinet, lid, control panel and shelves may be made from stainless steel. To keep the stainless steel looking its best is a simple matter. Clean it with soap and water, rinse with clear water and wipe dry. For stubborn particles, the use of a non-metallic brush can be used.

**⚠ IMPORTANT: Do not use a wire brush or abrasive cleaners on the stainless steel surfaces of your grill as this will cause scratches.**

**⚠ IMPORTANT: When cleaning surfaces be sure to rub/wipe in the direction of the grain to preserve the look of your stainless steel.**

**GAS INSTRUCTIONS**

**IMPORTANT LP CYLINDER INFORMATION**

Failure to follow these DANGER statements exactly may result in a fire causing death or serious injury.

**⚠ DANGER**

- ⚠ NEVER store a spare LP Cylinder under or near this barbecue.**
- ⚠ NEVER fill the tank beyond 80% full.**

Your Weber® gas grill is equipped for a cylinder supply system designed for vapor withdrawal.

**⚠ WARNING: Only use this grill outdoors in a well-ventilated area. Do not use in a garage, building, breezeway or any other enclosed area.**

The proper filling methods for the filling of your cylinder are by weight or volume, as described in NFPA 58. Please make sure your filling station fills your LP cylinder by weight or volume. Ask your filling station to read purging and filling instructions on the LP cylinder before attempting to fill.

**LEAK CHECK PREPARATION**

**CHECK THAT ALL BURNER VALVES ARE OFF**

Valves are shipped in the "OFF" position, but you should check to be sure that they are turned off. Check by pushing down and turning clockwise. If they do not turn, they are off. Proceed to the next step. If they do turn continue turning them clockwise until they stop, then they are off. Proceed to the next step.

**CONNECTING THE LIQUID PROPANE CYLINDER**

All Weber® liquid propane gas grill regulators are equipped with a UL-listed tank connection as per the latest edition of ANSI Z21.58. This will require a liquid propane tank that is similarly equipped with a Type 1 connection in the tank valve. This Type 1 coupling allows you to make a fast and totally safe hookup between your gas grill and your liquid propane tank. It eliminates the chance of leaks due to a POL fitting that is not properly tightened. Gas will not flow from the tank unless the Type 1 coupling is fully engaged into the tank coupling.

**⚠ WARNING: Make sure that the LP cylinder valve is closed. Close by turning valve clockwise.**

**⚠ DANGER**

**Do not use an open flame to check for gas leaks. Be sure there are no sparks or open flames in the area while you check for leaks. Sparks or flames will result in a fire or explosion which can cause serious bodily injury or death, and damage to property.**

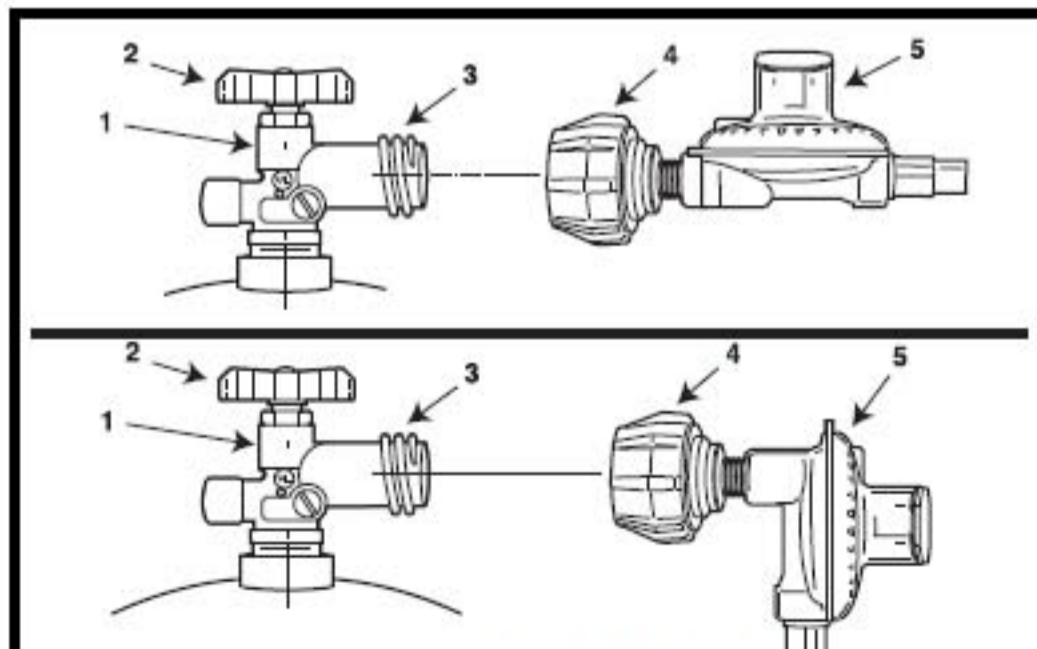

**TYPE 1 CONNECTIVE COUPLING**

1	Type 1 Valve
2	Hand Wheel
3	External Thread
4	Thermally Sensitive Nut
5	Propane Regulator

**To Connect the hose to the cylinder:**

- 1) Open base cabinet doors.
- 2) Pass the regulator hose through the side panel opening to the inside of the base cabinet.
- 3) Slide the hose retention bracket (1) along the hose and through the side panel opening to the inside of the base cabinet.
- 4) Position the hose retention bracket on the right inside panel and secure with two hex/washer/bolts (2).

**⚠ WARNING: The hose must be secured to the side panel with the Hose Retention Bracket. Failure to do so could cause damage to the hose resulting in a fire or explosion which can cause serious bodily injury or death, and damage to property.**

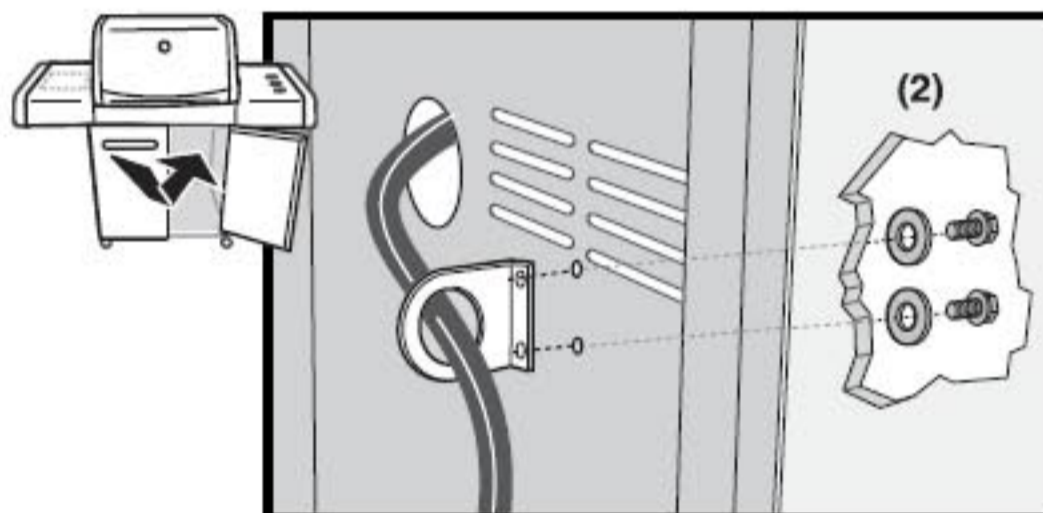
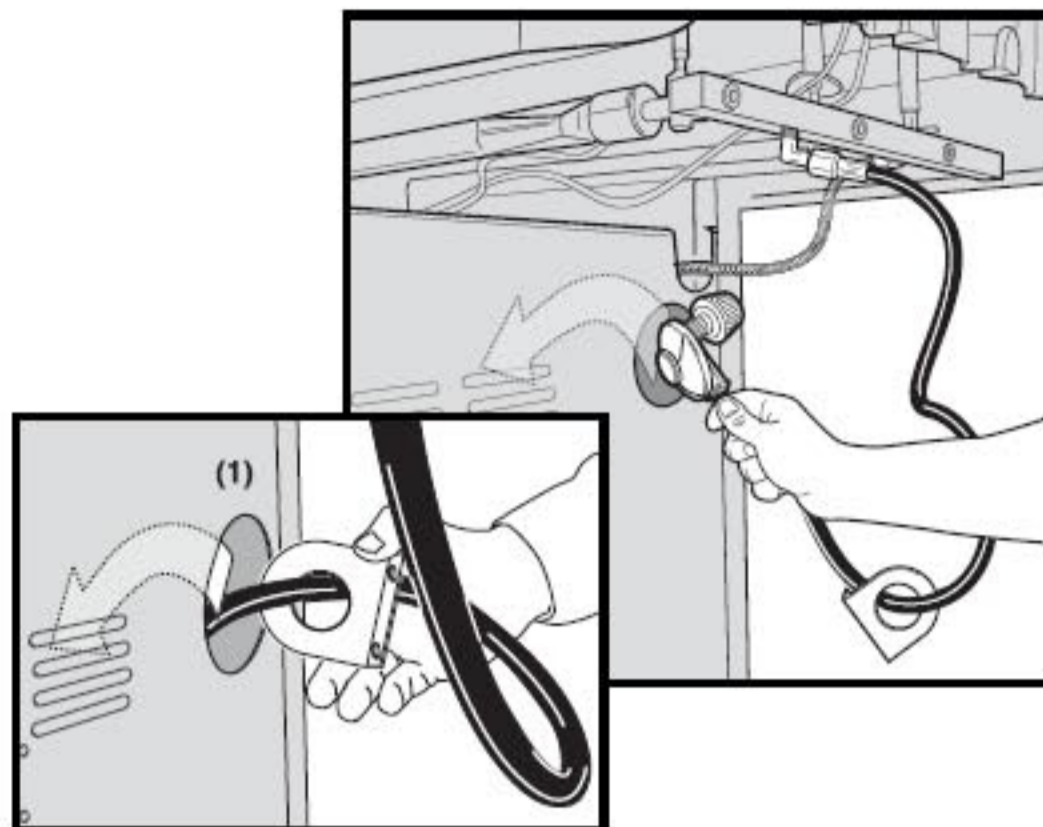

The LP cylinder is installed inside the base cabinet.

- 5) Turn the LP cylinder so the opening of the valve is either to the front, side or rear of the Weber® gas barbecue.
- 6) Lift and place the cylinder into the tank base opening in the bottom panel. Weber recommends the use of cylinder manufacturer's Manchester and Worthington, with a 47.6 lb water capacity. Other cylinders may be acceptable for use with the appliance provided they are compatible with the appliance retention means (see illustrations).
- 7) Remove the plastic dust cover from the valve.
- 8) Screw the regulator coupling onto the tank valve, clockwise, or to the right. Hand-tighten only.

*Note: This is a new type of connection. It tightens clockwise and will not allow gas to flow unless the connection is tight. The connection requires tightening by hand only.*

**⚠ WARNING: Do not use a wrench to tighten the connection. Using a wrench could damage the regulator coupling and could cause a leak.**

*You will need: LP cylinder, a soap and water solution and a rag or brush to apply it.*

- 9) Mix soap and water.
- 10) Turn on the cylinder valve.
- 11) Check for leaks by wetting the fitting with the soap and water solution and watching for bubbles. If bubbles form, or if a bubble grows, there is a leak.

**If there is a leak, turn off the gas and tighten the fitting. Turn the gas back on and recheck with the soap and water solution.**

**If leak does not stop, contact the Customer Service Representative in your area using the contact information on our web site. Log onto [www.weber.com](http://www.weber.com)®. Do not use the barbecue.**

- 12) When leak checking is complete, turn gas supply OFF at the source and rinse connections with water.

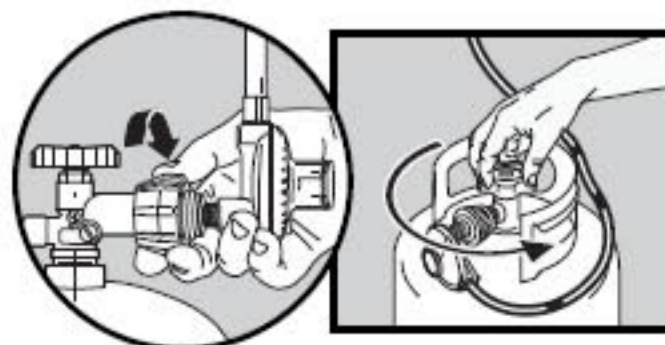
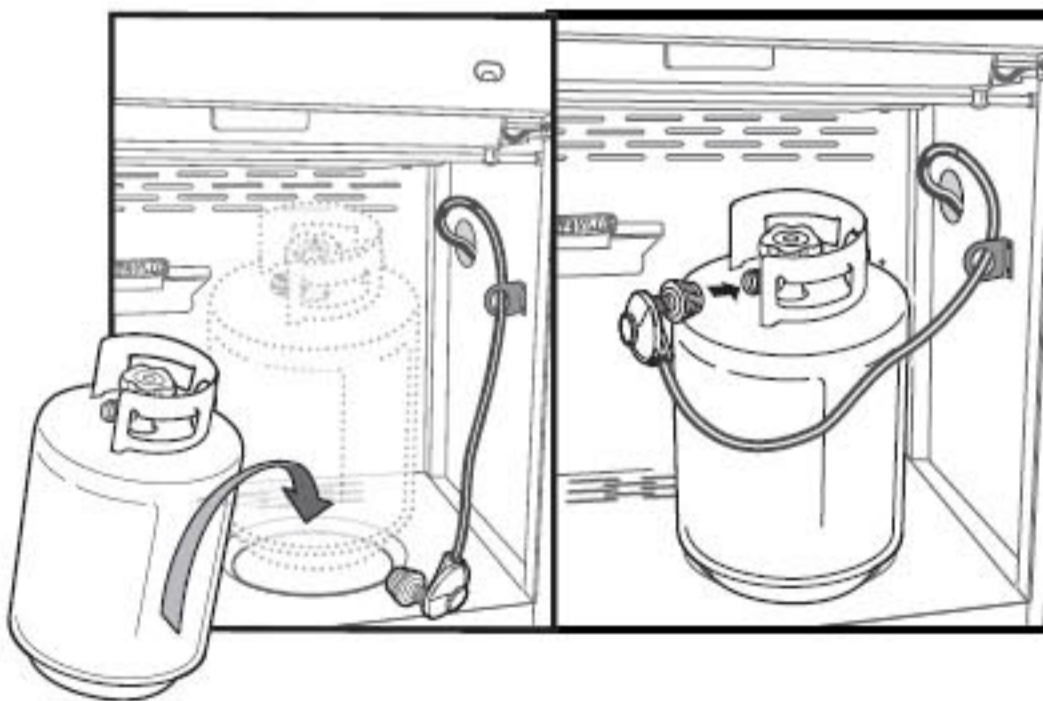

## REMOVE CONTROL KNOBS & CONTROL PANEL FOR LEAK TESTING

You will need: Phillips screwdriver.

- 1) Take off the burner control knobs.
- 2) Remove screw and washer from back of control panel with a Phillips screwdriver.
- 3) Remove machine screw from lower left and right side of control panel with a Phillips screwdriver.
- 4) Tilt the back edge of the control panel up. Carefully lift control panel up and away from frame.
- 5) Disconnect the igniter wires from the ignition module.
- 6) Replace control panel when Leak Check is completed.

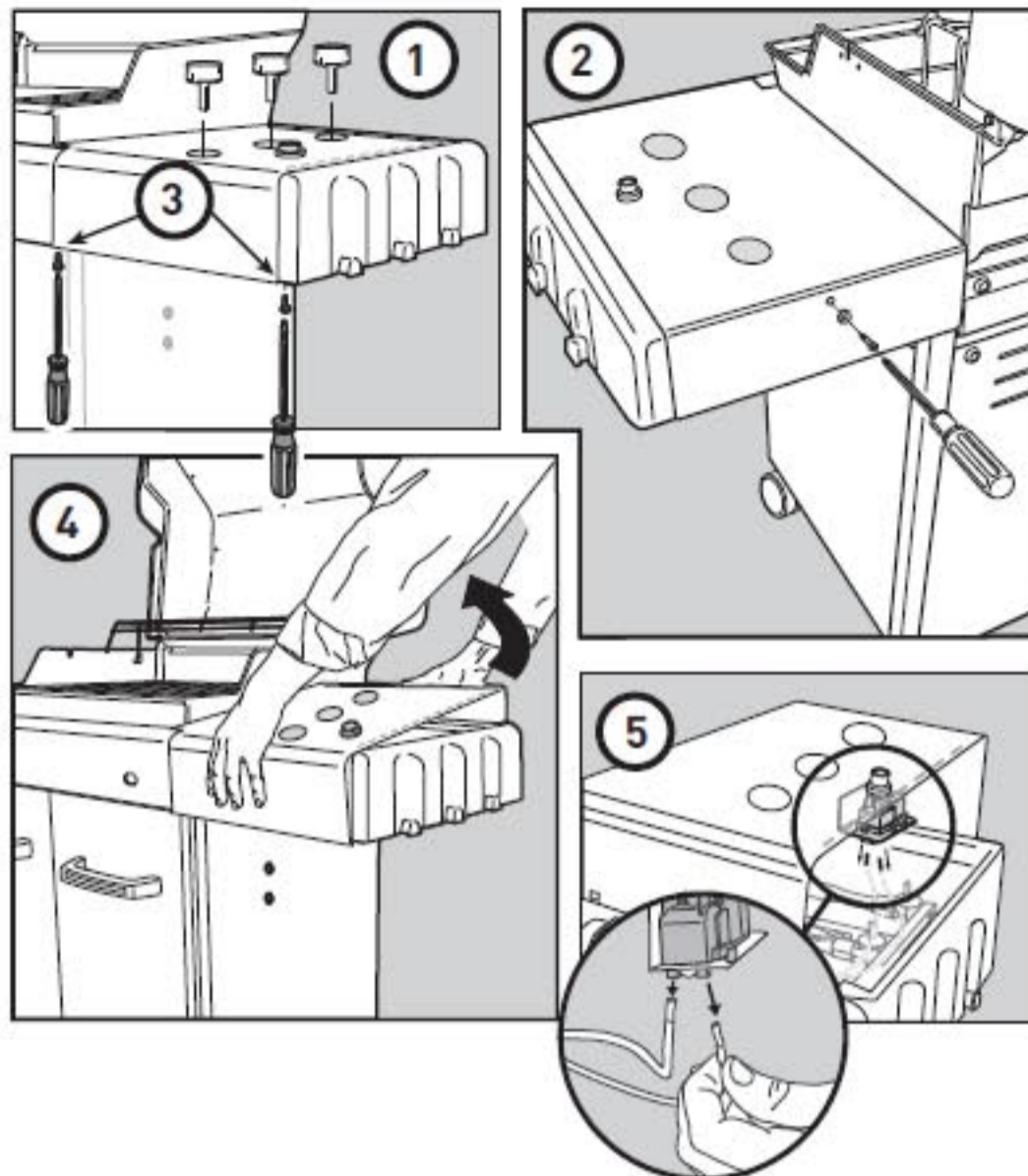

## CHECK FOR GAS LEAKS

### ⚠ DANGER

Do not use an open flame to check for gas leaks. Be sure there are no sparks or open flames in the area while you check for leaks. Sparks or open flames will result in a fire or explosion, which can cause serious bodily injury or death and damage to property.

**⚠ WARNING:** You should check for gas leaks every time you disconnect and reconnect a gas fitting.

*Note: All factory-made connections have been thoroughly checked for gas leaks. The burners have been flame-tested. As a safety precaution however, you should recheck all fittings for leaks before using your Weber® Gas Barbecue. Shipping and handling may loosen or damage a gas fitting.*

**⚠ WARNING:** Perform these leak checks even if your barbecue was dealer or store assembled.

You will need: a soap and water solution, and a rag or brush to apply it.

*Note: Since some leak test solutions, including soap and water, may be slightly corrosive, all connections should be rinsed with water after checking for leaks.*

If your grill has a side burner make sure the side burner is off.

To perform leak checks: open cylinder valve by turning the cylinder valve hand-wheel counterclockwise.

**⚠ WARNING:** Do not ignite burners when leak checking.

Check for leaks by wetting the connections with the soap and water solution and watching for bubbles. If bubbles form or if a bubble grows, there is a leak.

**Check:**

- 1) Hose to manifold connection.
- 2) Side burner hose to manifold connection and side burner hose to side burner gas line connection.
- 3) Side burner hose to side burner connection, side burner valve and orifice connections.

**⚠ WARNING:** If there is a leak at connection (1, 2, or 3), retighten the fitting with a wrench and recheck for leaks with soap and water solution. If a leak persists after re-tightening the fitting, turn OFF the gas. **DO NOT OPERATE THE GRILL.** Contact the Customer Service Representative in your area using the contact information on our web site. Log onto [www.weber.com](http://www.weber.com)®.

- 4) Regulator to cylinder connection.
- 5) Hose to regulator connection.
- 6) Valves to manifold connections.

**⚠ WARNING:** If there is a leak at connections (4, 5 or 6), turn OFF the gas. **DO NOT OPERATE THE GRILL.** Contact the Customer Service Representative in your area using the contact information on our web site. Log onto [www.weber.com](http://www.weber.com)®.

When leak checks are complete, turn gas supply OFF at the source and rinse connections with water.

**REFILLING THE LIQUID PROPANE CYLINDER**

We recommend that you refill the LP cylinder before it is completely empty.

**Removal of the LP cylinder**

- 1) Close cylinder valve (turn clockwise).
- 2) Unscrew regulator coupling by turning counterclockwise, by hand only.
- 3) Lift cylinder off.

To fill, take the LP cylinder to a gas propane dealer, or look up "gas-propane" in the phone book for other sources of LP gas.

**⚠ WARNING:** We recommend that your LP cylinder be filled at an authorized LP gas dealer, by a qualified attendant, who fills the cylinder by weight. **IMPROPER FILLING IS DANGEROUS.**

**⚠ CAUTION:** Place dust cap on cylinder valve outlet whenever the cylinder is not in use. Only install the type of dust cap on the cylinder valve outlet that is provided with the cylinder valve. Other types of caps or plugs may result in leakage of propane.

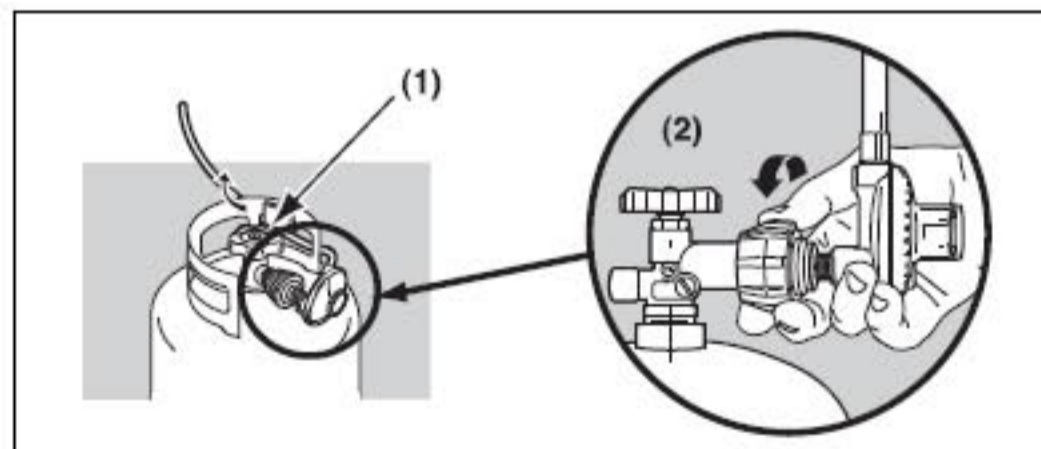
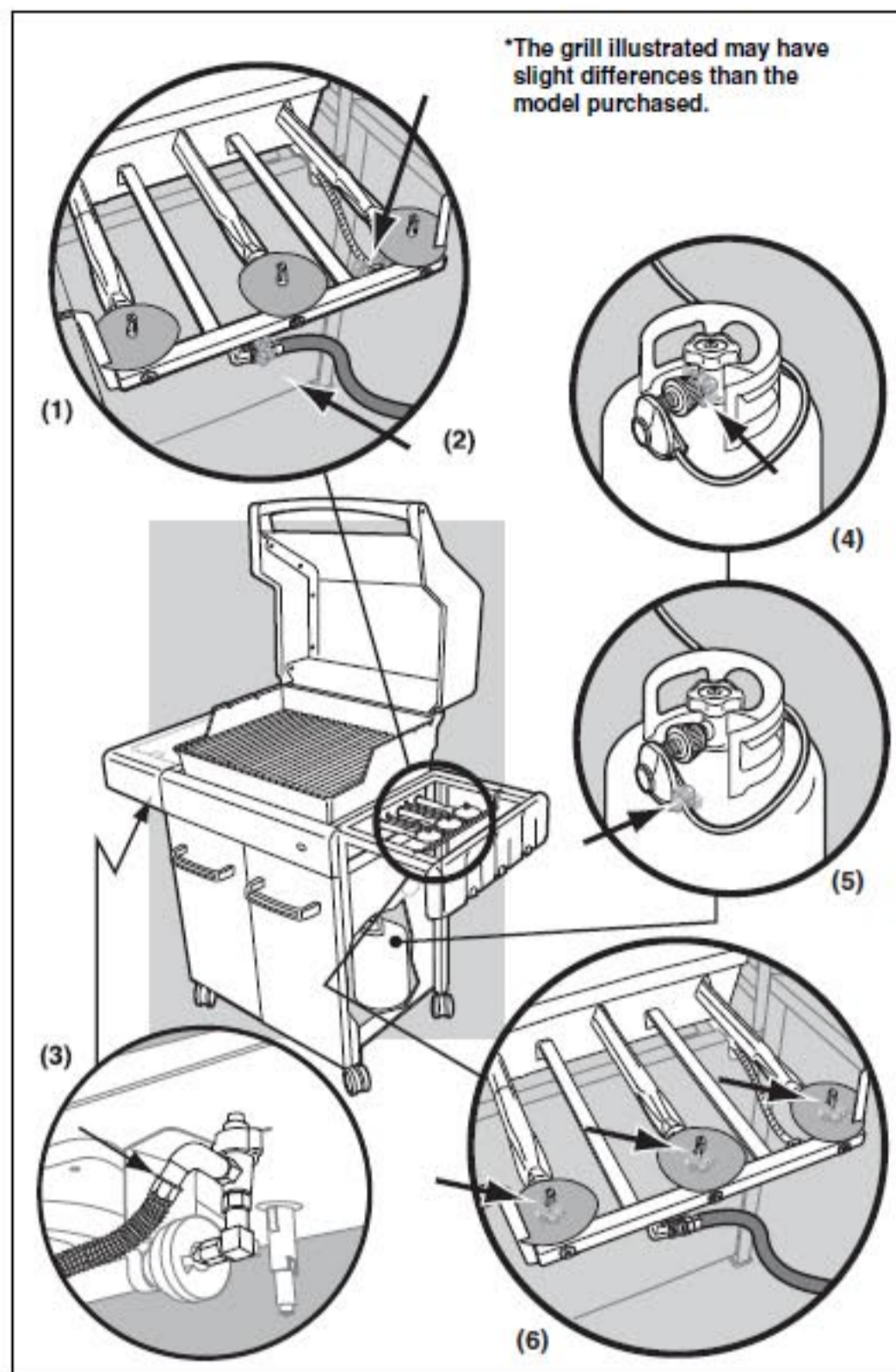

## SAFE HANDLING TIPS FOR LIQUID PROPANE GAS CYLINDERS

- Liquid Propane (LP) gas is a petroleum product as are gasoline and natural gas. LP gas is a gas at regular temperatures and pressures. Under moderate pressure, inside a cylinder, LP gas is a liquid. As the pressure is released, the liquid readily vaporizes and becomes gas.
- LP gas has an odor similar to natural gas. You should be aware of this odor.
- LP gas is heavier than air. Leaking LP gas may collect in low areas and prevent dispersion.
- To fill, take the LP cylinder to a gas propane dealer, or look up "gas-propane" in the phone book for other sources of LP gas.

**⚠ WARNING: We recommend that your LP cylinder be filled at an authorized LP gas dealer, by a qualified attendant, who fills the tank by weight. IMPROPER FILLING IS DANGEROUS.**

- Air must be removed from a new LP cylinder before the initial filling. Your LP dealer is equipped to do this.
- The LP cylinder must be installed, transported and stored in an upright position. LP cylinders should not be dropped or handled roughly.
- Never store or transport the LP cylinder where temperatures can reach 125° F (too hot to hold by hand - for example: do not leave the LP cylinder in a car on a hot day).

*Note: A refill will last about 18-20 hours of cooking time at normal use. The fuel scale will indicate the propane supply so you can refill before running out. You do not have to run out before you refill.*

- Treat "empty" LP cylinders with the same care as when full. Even when the LP tank is empty of liquid there still may be gas pressure in the cylinder. **Always close the cylinder valve before disconnecting.**

**⚠ CAUTION: Place dust cap on cylinder valve outlet whenever the cylinder is not in use. Only install the type of dust cap on the cylinder valve outlet that is provided with the cylinder valve. Other types of caps or plugs may result in leakage of propane.**

- Do not use a damaged LP cylinder. Dented or rusty LP cylinders or LP cylinders with a damaged valve may be hazardous and should be replaced with a new one immediately.

### Liquid Propane (LP) Cylinder(s)

- The joint where the hose connects to the LP cylinder must be leak tested each time the LP cylinder is reconnected. For example, test each time the LP cylinder is refilled.
- Be sure the regulator is mounted with the small vent hole pointed downward so that it will not collect water. This vent should be free of dirt, grease, bugs etc.
- The gas connections supplied with your Weber® gas barbecue have been designed and tested to meet 100% CSA and ANSI requirements.

**⚠ WARNING: Replacement LP tanks must match the regulator connection supplied with this barbecue.**

### LIQUID PROPANE CYLINDER REQUIREMENTS

- Check to be sure cylinders have a D.O.T. certification (1), and date tested (2) is within five years. Your LP gas supplier can do this for you.
- All LP tank supply systems must include a collar to protect the cylinder valve.
- The LP cylinder must be a 20-lb. size approximately (18¼ inches high, 12¼ inches in diameter).
- The cylinder must be constructed and marked in accordance with the Specifications for LP - Gas Cylinders of the U.S. Department of Transportation (D.O.T.) or the National Standard of Canada, CAN/CSA-B339, Cylinders, Spheres and Tubes or Transportation of Dangerous Goods; and Commission, as applicable.

### IN CANADA

### LIQUID PROPANE CYLINDER REQUIREMENTS

*Note: Your retailer can help you match a replacement tank to your barbecue.*

- The LP cylinder must be constructed and marked in accordance with the specifications for LP gas cylinders, T.C.

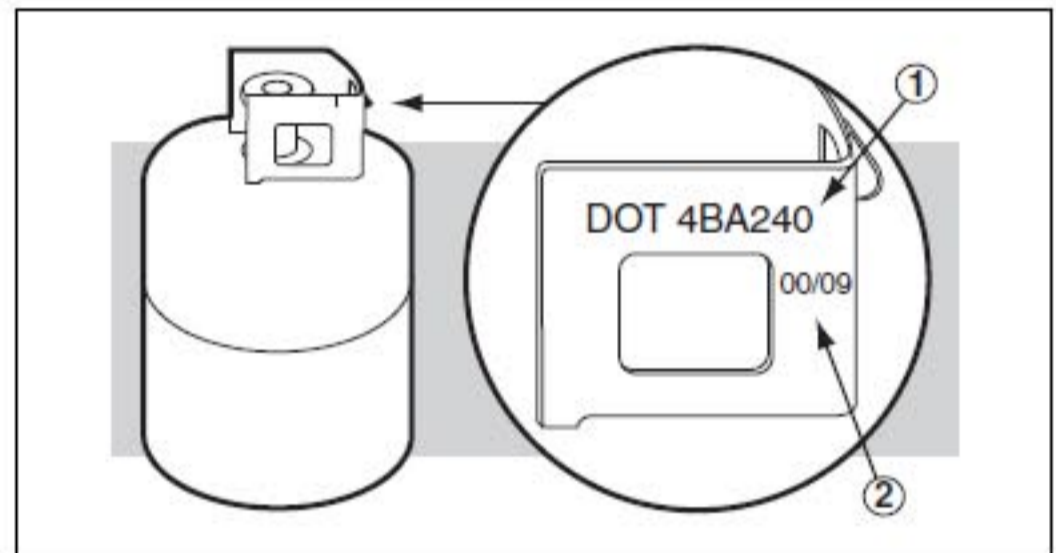

## OPERATING INSTRUCTIONS

### LIGHTING

*Summary lighting instructions are inside the left hand cabinet door.*

#### **⚠ DANGER**

**Failure to open the lid while igniting the barbecue's burners, or not waiting 5 minutes to allow the gas to clear if the barbecue does not light, may result in an explosive flame-up which can cause serious bodily injury or death.**

### CROSSOVER® IGNITION SYSTEM

*Note: The Crossover® Ignition System ignites BURNER 1 with a spark from the igniter electrode inside the Gas Catcher™ ignition chamber. You generate the energy for the spark by pushing the electronic ignition button. You will hear it sparking.*

**⚠ WARNING: Check hose before each use of barbecue for nicks, cracking, abrasions or cuts. If the hose is found to be damaged in any way, do not use the barbecue. Replace using only Weber® authorized replacement hose. Contact the Customer Service Representative in your area using the contact information on our web site. Log onto [www.weber.com](http://www.weber.com)®.**

### MAIN BURNER LIGHTING

- 1) Open the lid.
- 2) Make sure all burner control knobs are turned OFF. (Push control knob down and turn clockwise to ensure that it is in the OFF position.)

**⚠ WARNING:** The burner control knobs must be in the OFF position before turning on the liquid propane cylinder tank valve. If they are not in the OFF position, when you turn on the LP cylinder valve, the “excess gas flow control” feature will activate, limiting the flow of gas from the LP cylinder. If this should occur, turn OFF the LP cylinder valve and burner control knobs. Start over.

#### ⚠ DANGER

When the “excess gas flow control” feature is activated, a small amount of gas is still flowing to the burners. After turning OFF the cylinder valve, wait at least 5 minutes for the gas to clear before attempting to light the barbecue. Failure to do so may result in an explosive flame-up, which can cause serious bodily injury or death.

- 3) Turn the cylinder on by slowly turning the cylinder valve counterclockwise.
  - ⚠ WARNING:** Do not lean over the open barbecue. Keep your face and body at least one foot away from the matchlight hole when lighting the barbecue.
  - 4) Push BURNER 1 control knob down and turn to START/HI.
  - 5) Push and hold the electronic ignition button. You will hear it sparking.
  - 6) Check that the burner is lit by looking through the matchlight hole on the front of the cooking box. You should see a flame.
- ⚠ WARNING:** If the burner does not light in five (5) seconds, turn the Burner 1 control knob to OFF and wait 5 minutes to let the gas clear before you try again or try to light with a match.

- 7) After BURNER 1 is lit you can turn on BURNER 2 (and BURNER 3).
- Note - Always light BURNER 1 first. The other burners ignite from BURNER 1.

### TO EXTINGUISH

Push down and turn each burner control knob clockwise to the OFF position. Turn gas supply OFF at the source.

### MAIN BURNER MANUAL LIGHTING

#### ⚠ DANGER

Failure to open the lid while igniting the barbecue’s burners, or not waiting 5 minutes to allow the gas to clear if the barbecue does not light, may result in an explosive flame-up which can cause serious bodily injury or death.

- 1) Open the lid.
  - 2) Make sure all burner control knobs are turned OFF. (Push each knob down and turn clockwise to ensure they are in the “OFF” position.)
- ⚠ WARNING:** The burner control knobs must be in the OFF position before turning on the liquid propane cylinder valve. If they are not in the OFF position, when you turn on the LP cylinder valve, the “excess gas flow control” feature will activate, limiting the flow of gas from the LP cylinder. If this should occur, turn OFF the LP tank valve and burner control knobs. Start over.

### MAIN BURNER LIGHTING

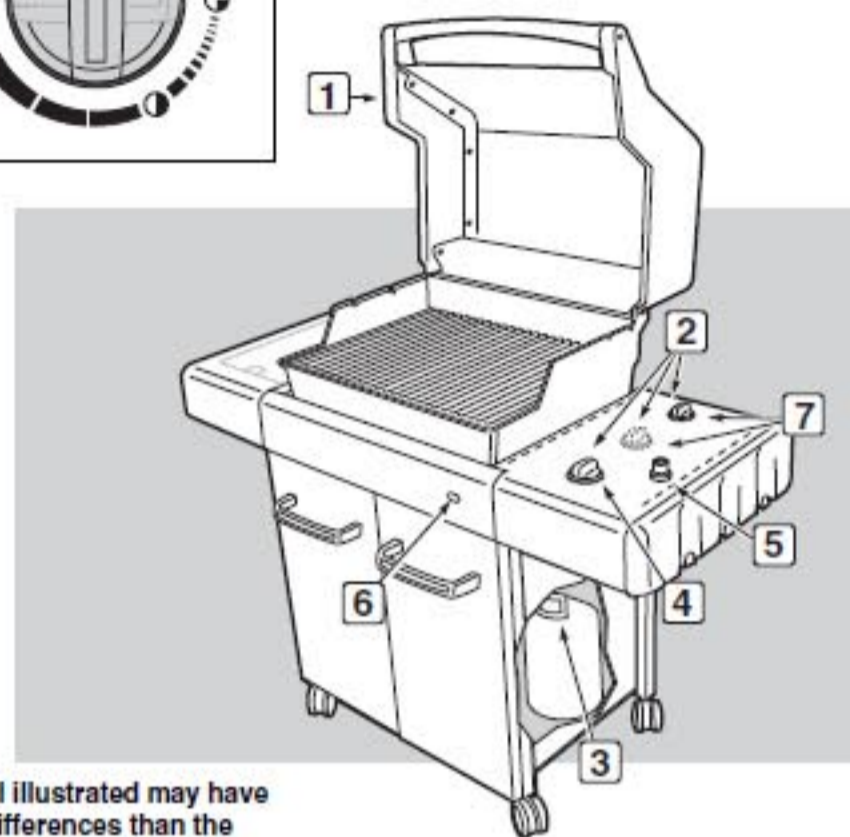
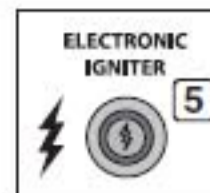
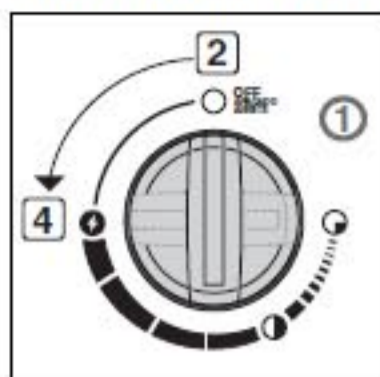

\*The grill illustrated may have slight differences than the model purchased.

### MAIN BURNER MANUAL LIGHTING

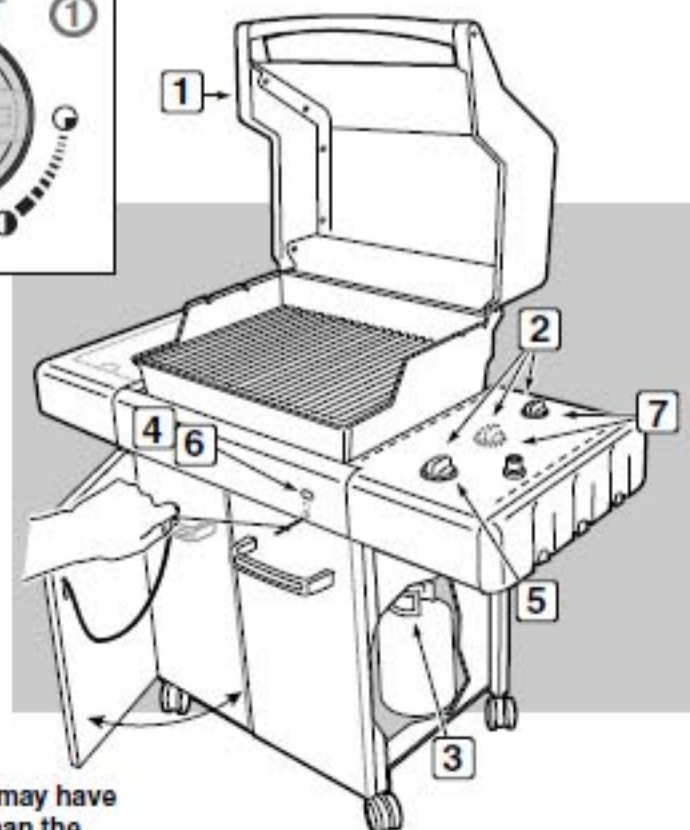
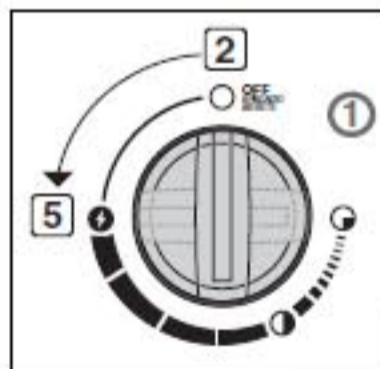

\*The grill illustrated may have slight differences than the model purchased.

**⚠ DANGER**

When the "excess gas flow control" feature is activated, a small amount of gas is still flowing to the burners. After turning OFF the cylinder and burner control knobs, wait at least 5 minutes for the gas to clear before attempting to light the barbecue. Failure to do so may result in an explosive flame-up, which can cause serious bodily injury or death.

- 3) Turn the cylinder on by turning the cylinder valve counterclockwise.
  - 4) Insert match holder with lit match into the matchlight hole in the front of the cooking box.
- ⚠ WARNING: Do not lean over open barbecue. Keep your face and body at least one foot away from the matchlight hole when lighting the barbecue.**
- 5) Push BURNER 1 control knob down and turn to START/Hi.
  - 6) Check that the burner is lit by looking through the matchlight hole on the front of the cooking box. You should see a flame.
- ⚠ WARNING: If the burner does not light in five seconds, turn the Burner 1 control knob to OFF and wait 5 minutes to let the gas clear before you try again.**
- 7) After BURNER 1 is lit you can turn on BURNER 2 (and BURNER 3).
- Note - Always light BURNER 1 first. The other burners ignite from BURNER 1.*

**TO EXTINGUISH**

Push down and turn each burner control knob clockwise to the OFF position. Turn gas supply OFF at the source.

**MAIN BURNER MANUAL LIGHTING**

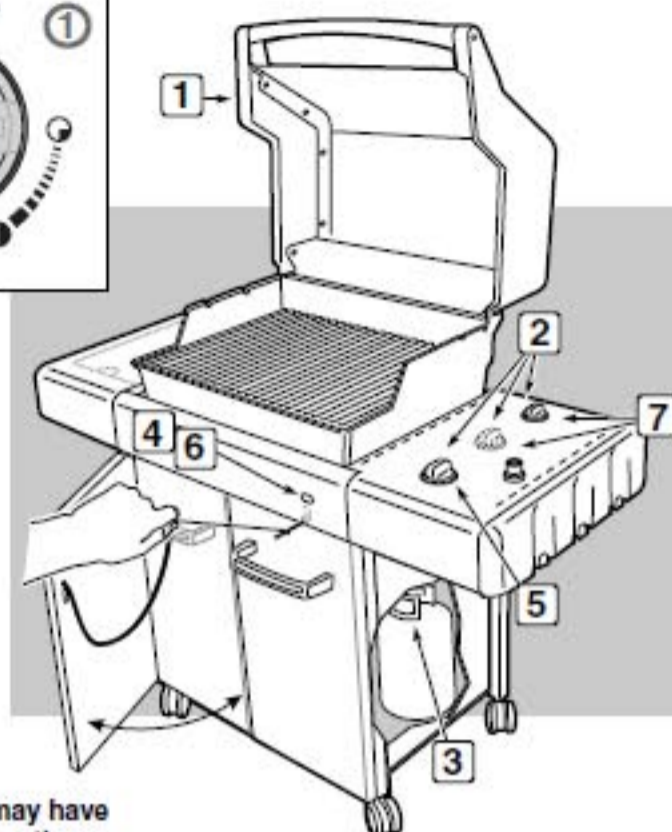
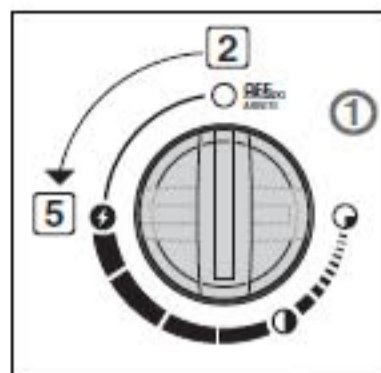

\*The grill illustrated may have slight differences than the model purchased.

**LIGHTING THE SIDE BURNER**

**⚠ DANGER**

Failure to open the lid while igniting the side burner, or not waiting 5 minutes to allow the gas to clear if the side burner does not light, may result in an explosive flame-up which can cause serious bodily injury or death.

- ⚠ WARNING: Check hose before each use of barbecue for nicks, cracking, abrasions or cuts. If the hose is found to be damaged in any way, do not use the barbecue. Replace using only Weber® authorized replacement hose. Contact the Customer Service Representative in your area using the contact information on our web site. Log onto [www.weber.com](http://www.weber.com)®.**
- 1) Open the side burner lid.
  - 2) Check that the side burner valve is turned off (Push control knob in and turn clockwise to ensure that it is in the "OFF" position), turn all burners not being used to the "OFF" position (push in and turn clockwise).
  - 3) Turn the gas supply valve on.
  - 4) Push down and turn the side burner control valve to "Hi".
  - 5) Press the igniter button several times so it clicks each time.
- ⚠ CAUTION: Side burner flame may be difficult to see on a bright sunny day.**
- ⚠ WARNING: If the side burner does not light in five (5) seconds:**
- a) Turn off the side burner control valve, main burners and gas supply at source.
  - b) Wait 5 minutes to let the gas clear before you try again, or try lighting with a match (see "Manually Lighting the Side Burner").

**SIDE BURNER LIGHTING**

\*The grill illustrated may have slight differences than the model purchased.

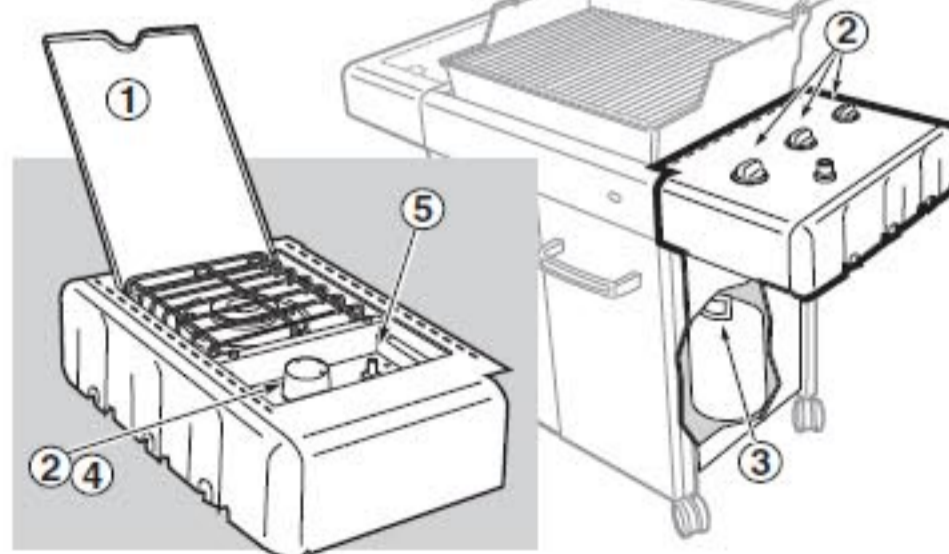

## MANUALLY LIGHTING THE SIDE BURNER

**⚠ DANGER**

Failure to open the lid while igniting the side burner, or not waiting 5 minutes to allow the gas to clear if the side burner does not light, may result in an explosive flare-up that can cause serious bodily injury or death.

- 1) Open the side burner lid.
- 2) Check that the side burner valve is turned off (Push control knob in and turn clockwise to ensure that it is in the "OFF" position), turn all burners not being used to the "OFF" position (push in and turn clockwise).
- 3) Turn the gas supply valve on.
- 4) Put match in a match holder and strike match.
- 5) Hold match holder and lit match by either side of the side burner.
- 6) Push down and turn the side burner control valve to "HI".

**⚠ CAUTION:** Side burner flame may be difficult to see on a bright sunny day.

**⚠ WARNING:** If the side burner does not light in five (5) seconds:

- a) Turn off the side burner control valve, main burners and gas supply at source.
- b) Wait 5 minutes to let the gas clear before you try again.

## SIDE BURNER MANUAL LIGHTING

\*The grill illustrated may have slight differences than the model purchased.

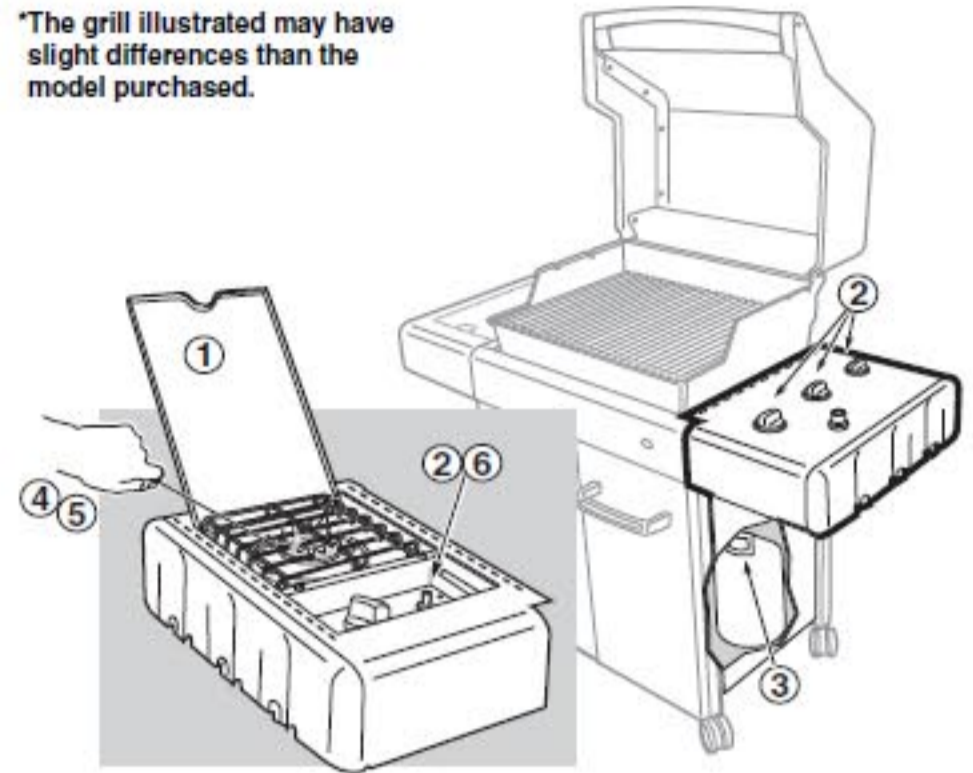

## TROUBLESHOOTING

PROBLEM	CHECK	CURE
Burners burn with a yellow or orange flame, in conjunction with the smell of gas.	Inspect Spider/Insect Screens for possible obstructions. (Blockage of holes.)	Clean Spider/Insect Screens. (See Section "Annual Maintenance")
<i>Symptoms:</i> Burners do not light. -or- Burners have a small flickering flame in the "HI" position. -or- Barbecue temperature only reaches 250° to 300° in the "HI" position.	The excess flow safety device, which is part of the barbecue to cylinder connection, may have activated.	To reset the excess flow safety device turn all burner control knobs and the cylinder valve off. Disconnect the regulator from the cylinder. Turn burner control knobs to "HI". Wait at least 1 minute. Turn burner control knobs to "OFF". Reconnect the regulator to the cylinder. Turn cylinder valve on slowly. Refer to "Lighting Instructions".
Burner does not light, or flame is low in "HI" position.	Is LP fuel low or empty?	Refill LP cylinder.
	Is fuel hose bent or kinked?	Straighten fuel hose.
	Does Burner 1 light with a match?	If you can light Burner 1 with a match, then check the Crossover® ignition system.
Experiencing flare-ups:	Are you preheating barbecue in the prescribed manner?	All burners on HI for 10 to 15 minutes for preheating.
	Are the cooking grates and Flavorizer® bars heavily coated with burned-on grease?	Clean thoroughly. (See Section "Cleaning")
	Is the bottom tray "dirty" and not allowing grease to flow into catch pan?	Clean bottom tray.
<b>⚠ CAUTION:</b> Do not line the bottom tray with aluminum foil.		
Burner flame pattern is erratic. Flame is low when burner is on "HI". Flames do not run the whole length of the burner tube.	Are burners clean?	Clean burners. (See Section "Maintenance".)
Inside of lid appears to be "peeling." (Resembles paint peeling.)	The lid is porcelain enamel or stainless steel, not paint. It cannot "peel". What you are seeing is baked on grease that has turned to carbon and is flaking off. <b>THIS IS NOT A DEFECT.</b>	Clean thoroughly. (See Section "Cleaning".)
Cabinet doors are not aligned.	Check the adjustment pin on the bottom of each door.	Loosen adjustment nut/s. Slide door/s until aligned. Tighten nut.

If problems cannot be corrected by using these methods, please contact the Customer Service Representative in your area using the contact information on our web site. Log onto [www.weber.com](http://www.weber.com)®.

PROBLEM	CHECK	CURE
Side Burner burns with a yellow or orange flame, in conjunction with the smell of gas.	Inspect side burner orifice alignment (Position of orifice to side burner tube.)	Loosen orifice and re-align orifice parallel to the side burner tube (3) . (See Section "Side Burner Maintenance")
Side Burner does not light.	Is gas supply off?  The excess flow safety device, which is part of the barbecue to cylinder connection, may have activated.	Turn supply on.  To reset the excess flow safety device turn all burner control knobs and the cylinder valve off. Disconnect the regulator from the cylinder. Turn burner control knobs to START/Hi. Wait at least 1 minute. Turn burner control knobs to "OFF". Reconnect the regulator to the cylinder. Turn cylinder valve on slowly. Refer to "Lighting Instructions".
Flame is low in "HI" position.	Is the fuel hose bent or kinked?	Straighten hose.
Push button ignition does not work.	Does burner light with a match?	If match lights burner, check igniter (see Sideburner Maintenance).

If problems cannot be corrected by using these methods, please contact the Customer Service Representative in your area using the contact information on our web site. Log onto [www.weber.com](http://www.weber.com).

## SIDE BURNER MAINTENANCE

**⚠ WARNING: All gas controls and supply valves should be in the "OFF" position.**

Make sure black wire is connected between the igniter and electrode.  
Make sure white wire is connected between the igniter and grounding clip.  
Spark should be a white/blue color, not yellow.

- 1) Igniter Wire
- 2) Ground wire
- 3) Burner

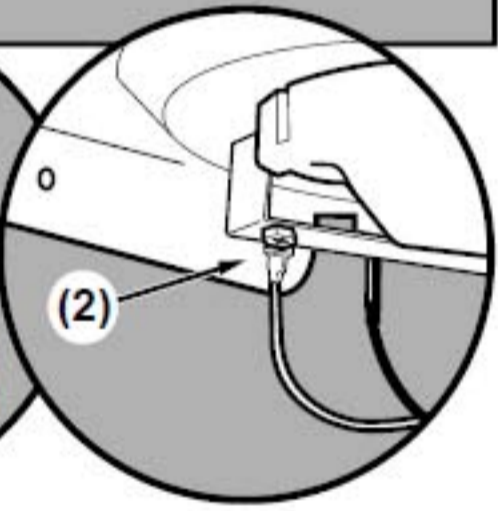
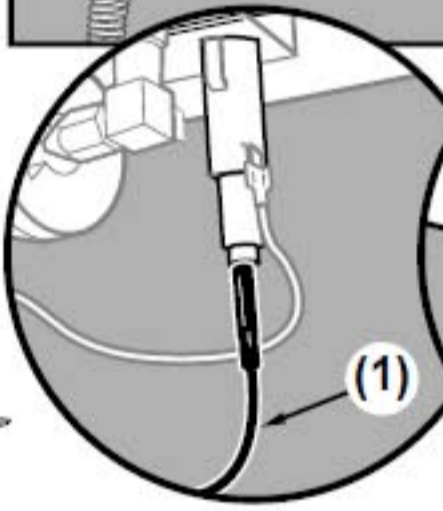
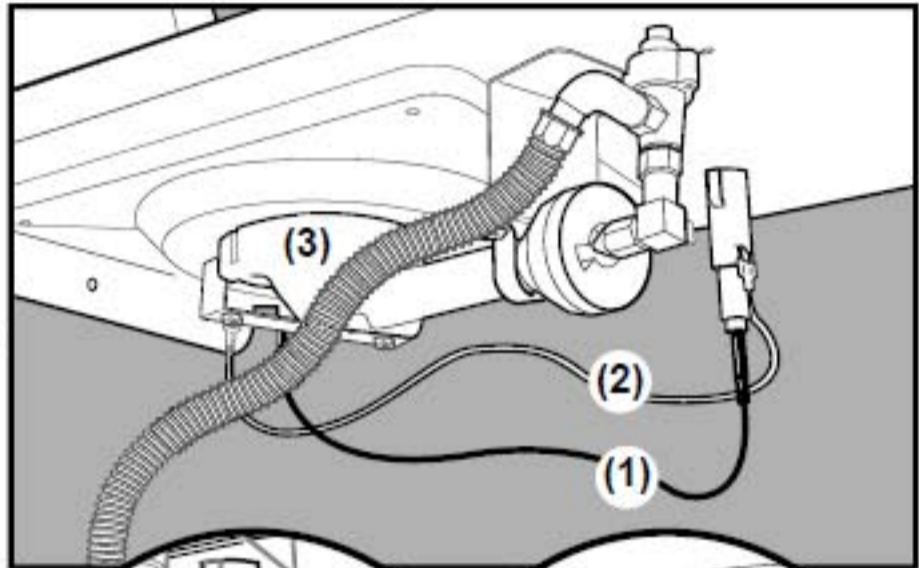
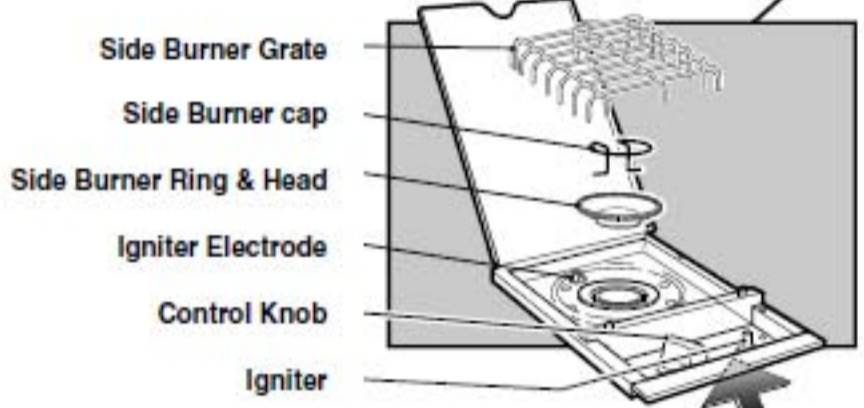

**⚠ WARNING: The side burner orifice (4) must be parallel to the side burner tube opening (5).**

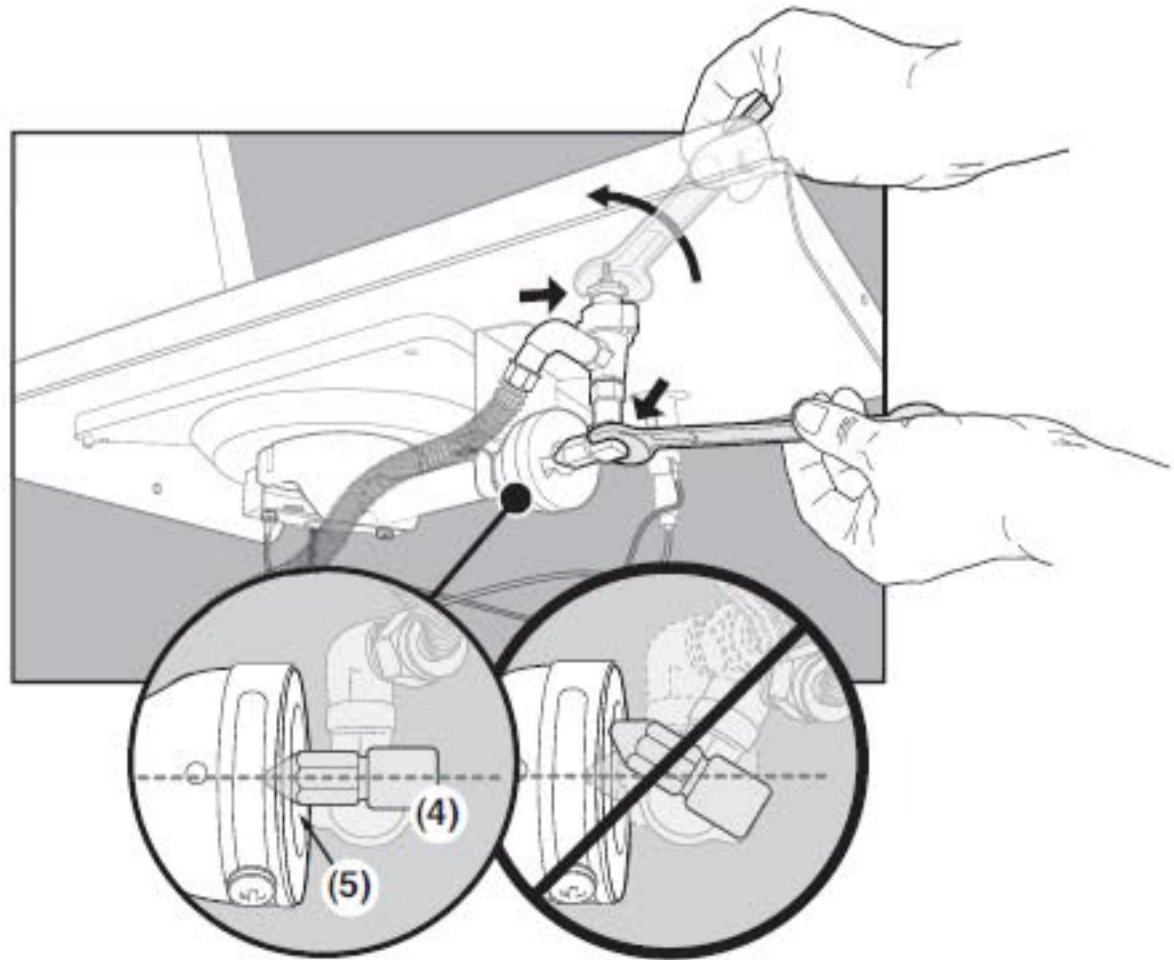

## WEBER® SPIDER/INSECT SCREENS

Your Weber® gas barbecue, as well as any outdoor gas appliance, is a target for spiders and other insects. They can nest in the venturi section (1) of the burner tubes. This blocks the normal gas flow, and can cause the gas to flow back out of the combustion air opening. This could result in a fire in and around the combustion air openings, under the control panel, causing serious damage to your barbecue.

The burner tube combustion air opening is fitted with a stainless steel screen (2) to prevent spiders and other insects access to the burner tubes through the combustion air openings.

We recommend that you inspect the Spider/Insect screens at least once a year. (See Section "Annual Maintenance".) Also inspect and clean the the Spider/Insect screens if any of the following symptoms should ever occur:

- 1) The smell of gas in conjunction with the burner flames appearing yellow and lazy.
- 2) Barbecue does not reach temperature.
- 3) Barbecue heats unevenly.
- 4) One or more of the burners do not ignite.

### ⚠ DANGER

Failure to correct the above mentioned symptoms may result in a fire, which can cause serious bodily injury or death, and cause damage to property.

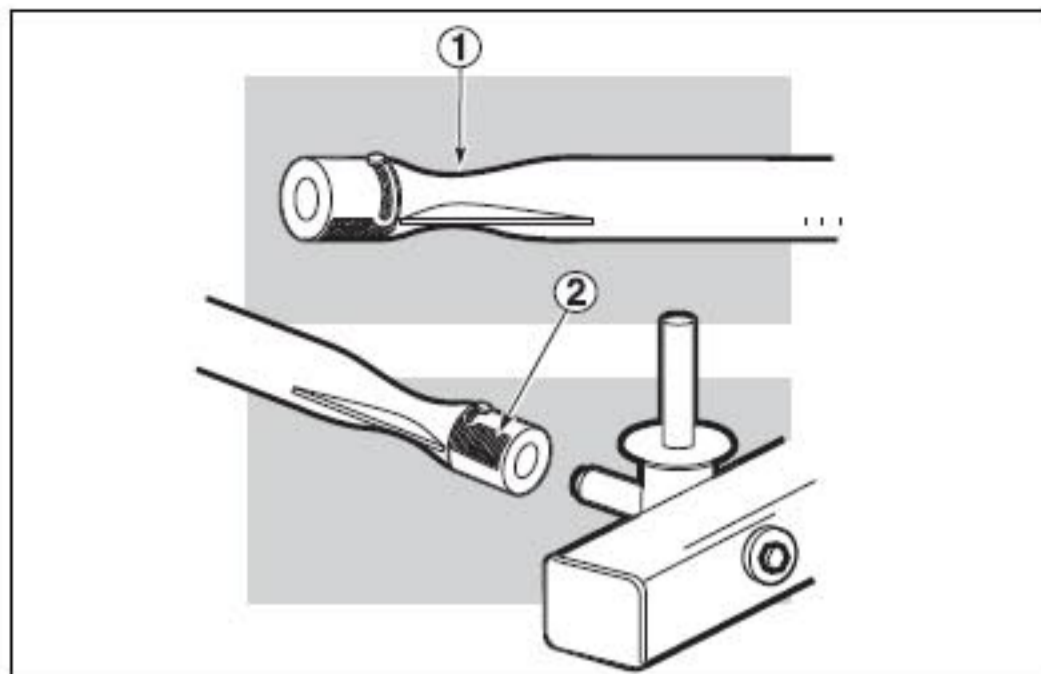

## ANNUAL MAINTENANCE

### INSPECTION AND CLEANING OF THE SPIDER/INSECT SCREENS

To inspect the Spider/Insect screens, remove the control panel. If there is dust or dirt on the screens, remove the burners for cleaning the screens.

Brush the Spider/Insect screens lightly with a soft bristle brush (i.e. an old toothbrush).

**⚠ CAUTION: Do not clean the Spider/Insect screens with hard or sharp tools. Do not dislodge the Spider/Insect screens or enlarge the screen openings.**

Lightly tap the burner to get debris and dirt out of the burner tube. Once the Spider/Insect screens and burners are clean replace the burners.

If the Spider/Insect screen becomes damaged or cannot be cleaned, please contact the Customer Service Representative in your area using the contact information on our web site. Log onto [www.weber.com](http://www.weber.com)®.

## BURNER FLAME PATTERN

The Weber® gas barbecue burners have been factory set for the correct air and gas mixture. The correct flame pattern is shown.

- 1) Burner tube
- 2) Tips occasionally flicker yellow
- 3) Light blue
- 4) Dark blue

If the flames do not appear to be uniform throughout the burner tube, follow the burner cleaning procedures.

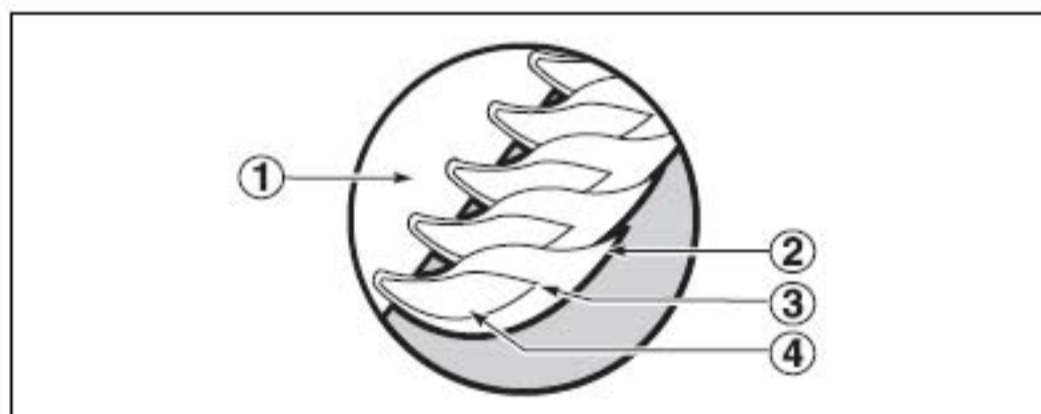

**MAIN BURNER CLEANING PROCEDURE**

**Turn off the gas supply.**

Remove the manifold (See "Replacing Main Burners").

Look inside each burner with a flashlight.

Clean the inside of the burners with a wire (a straightened-out coat hanger will work).

Check and clean the air shutter opening at the ends of the burners. Check and clean the valve orifices at the base of the valves. Use a Steel bristle brush to clean outside of burners. This is to make sure all the burner ports are fully open.

**⚠ CAUTION: Do not enlarge the burner ports when cleaning.**

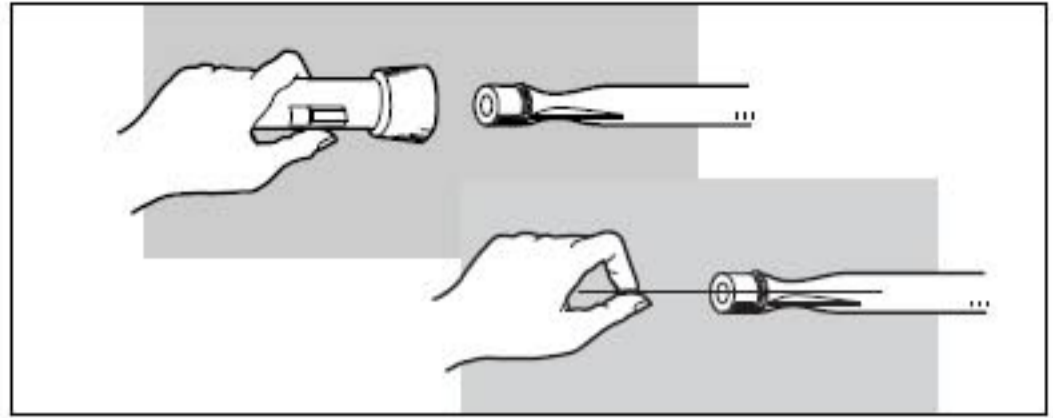

**REPLACING MAIN BURNERS**

- 1) Your Weber® gas barbecue must be OFF and cool.
- 2) Turn gas OFF at source.
- 3) To remove control panel:
  - (a) Take off the burner control knobs.
  - (b) Remove screw and washer from back of control panel with a Phillips screwdriver.
  - (c) Remove machine screw from lower left side of control panel with a Phillips screwdriver.
  - (d) Tilt the back edge of the control panel up. Carefully lift control panel up and away from frame.
  - (e) Disconnect the igniter wires from the ignition module.
  - (f) Replace control panel when Leak Check is completed.

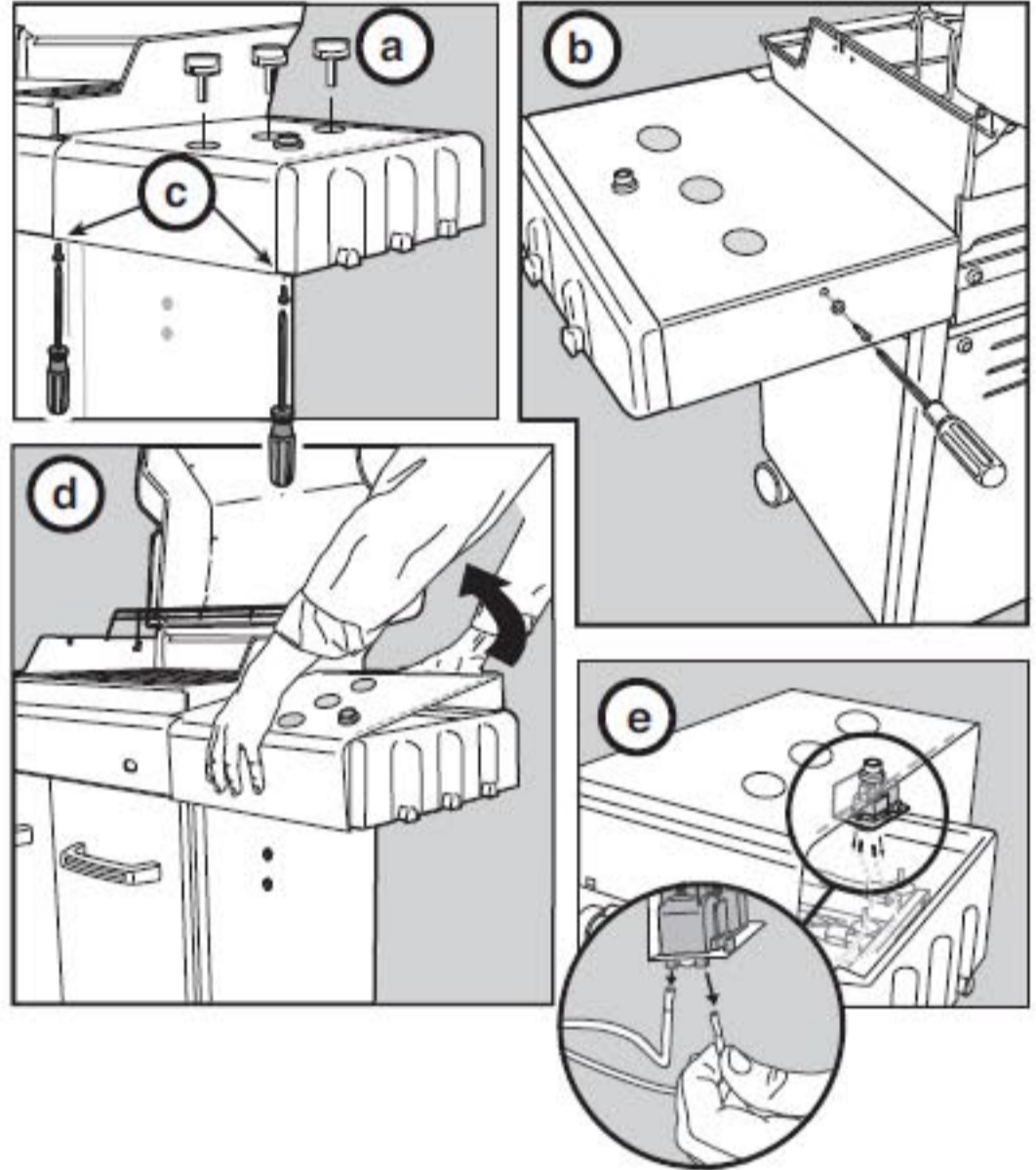

- 4) Remove the two nuts (a) that hold the manifold support bracket to the cooking box. Allow the manifold support bracket to pivot down away from the cookbox, releasing the valve assembly from the burners (b).

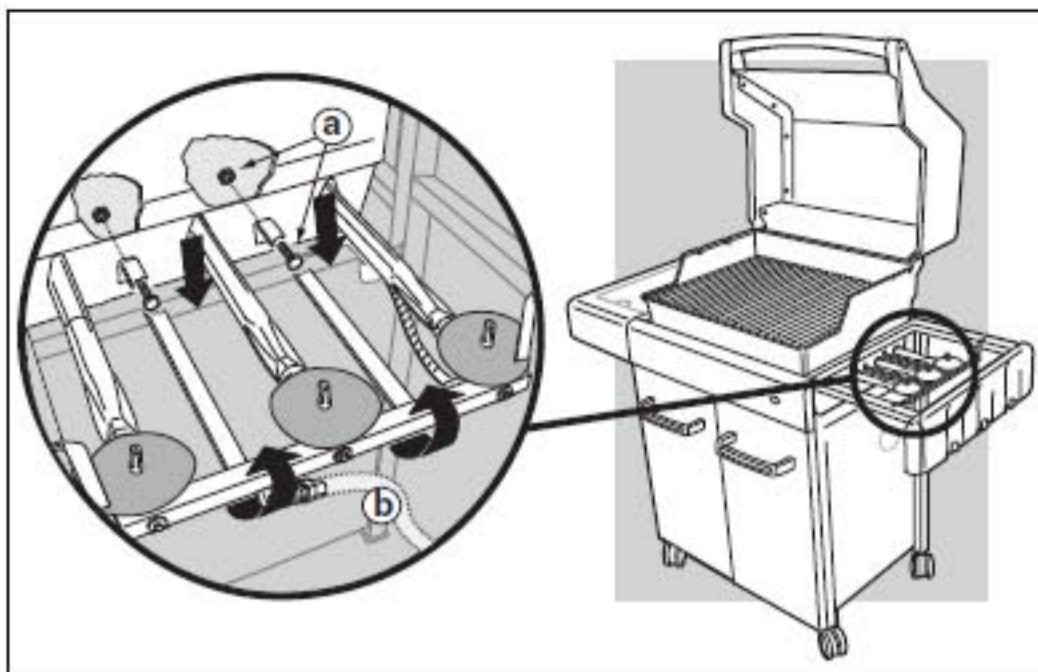

- 5) Slide the burner assembly out from under the guide screw and washer (a) in the corners of the cooking box.  
6) Lift and twist the burner assembly slightly, to separate the crossover tube (b) from the burners. Remove the burners from the cooking box.  
7) To reinstall the burners, reverse 3) through 7).

**⚠ CAUTION:** The burner openings (c) must be positioned properly over the valve orifices (d).

Check proper assembly before fastening manifold in place.

**⚠ WARNING:** After reinstalling the gas lines, they should be leak checked with a soap and water solution before using the barbecue. (See Step: "Check for gas leaks.")

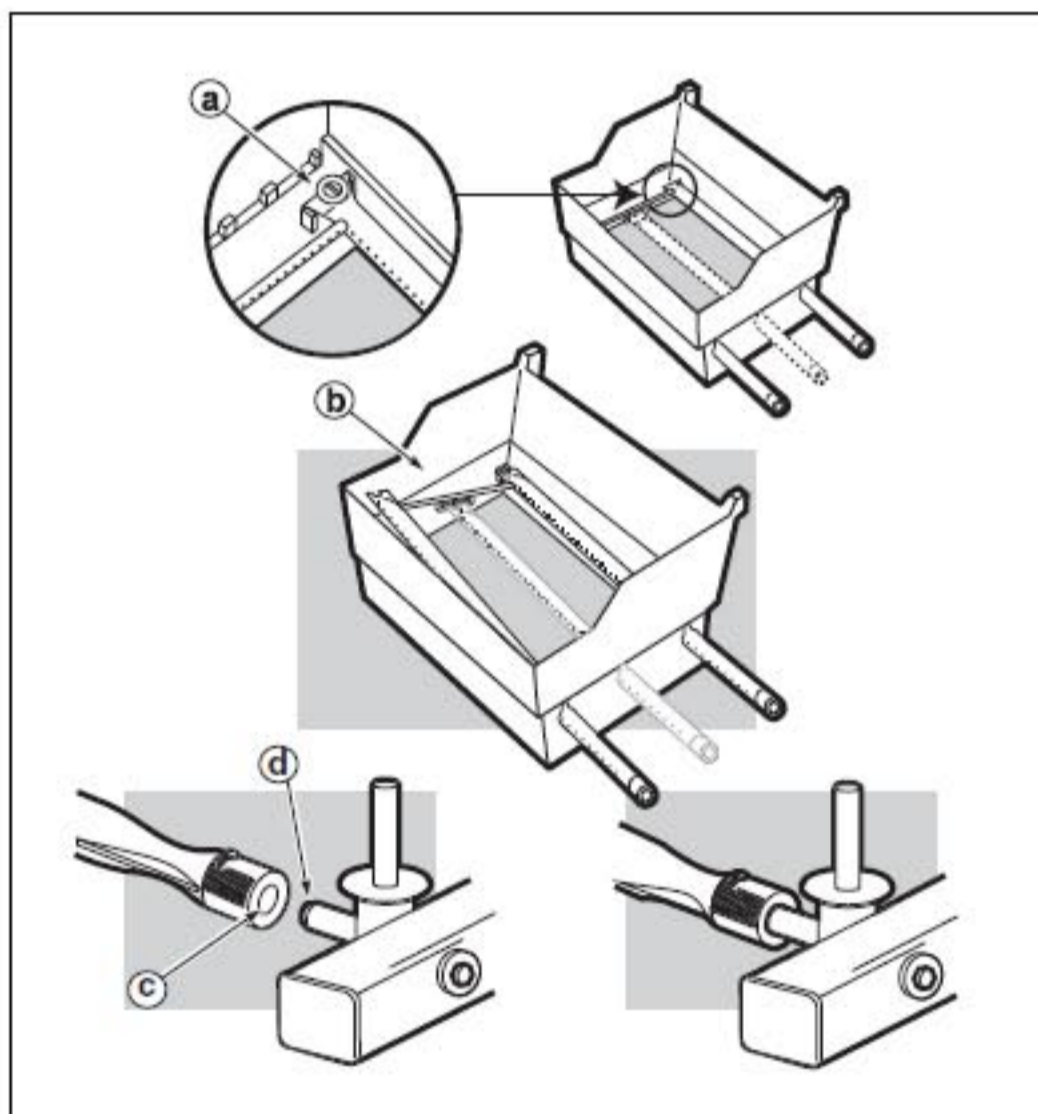

### CROSSOVER® IGNITION SYSTEM OPERATIONS

If The Crossover® Ignition System fails to ignite the BURNER 1, light BURNER 1 with a match. If BURNER 1 lights with a match, then check the Electronic Ignition System.

- Check that both of the ignition wires are attached at the igniter module properly.
- Check that the Electronic Ignition Button is working by listening and looking for sparks at BURNER 1.

### REPLACE BATTERY IF NECESSARY

AAA alkaline battery only. See illustration:

If the Electronic Ignition System still fails to light, contact the Customer Service Representative in your area using the contact information on our web site. Log onto [www.weber.com](http://www.weber.com)®.

