

HEAT CONTROLLER, INC.



**Wall Mounted
Mini-Split System
Air Conditioning/Heat Pump**
Service Manual

Model: B/A-HMC09AS
B/A-HMC12AS, B/A-HMH12AS
B/A-HMC18AS, B/A-HMH18AS
B/A-HMC24AS, B/A-HMH24AS

CAUTION

Before servicing the unit, read the
“safety precautions” in this manual.

Only for authorized service personnel.

Contents

Functions	3
Product Specifications	5
Dimensions.....	7
Refrigeration Cycle Diagram.....	10
Wiring Diagram	12
Operation Details	15
Display Function	22
Self-diagnosis Function	22
Installation	23
Operation	38
Disassembly of the Parts(Indoor Unit).....	40
Cycle Troubleshooting Guide	46
Electronic Control Device	56
Schematic Diagram.....	59
Exploded View and Replacement Parts List.....	60

Functions

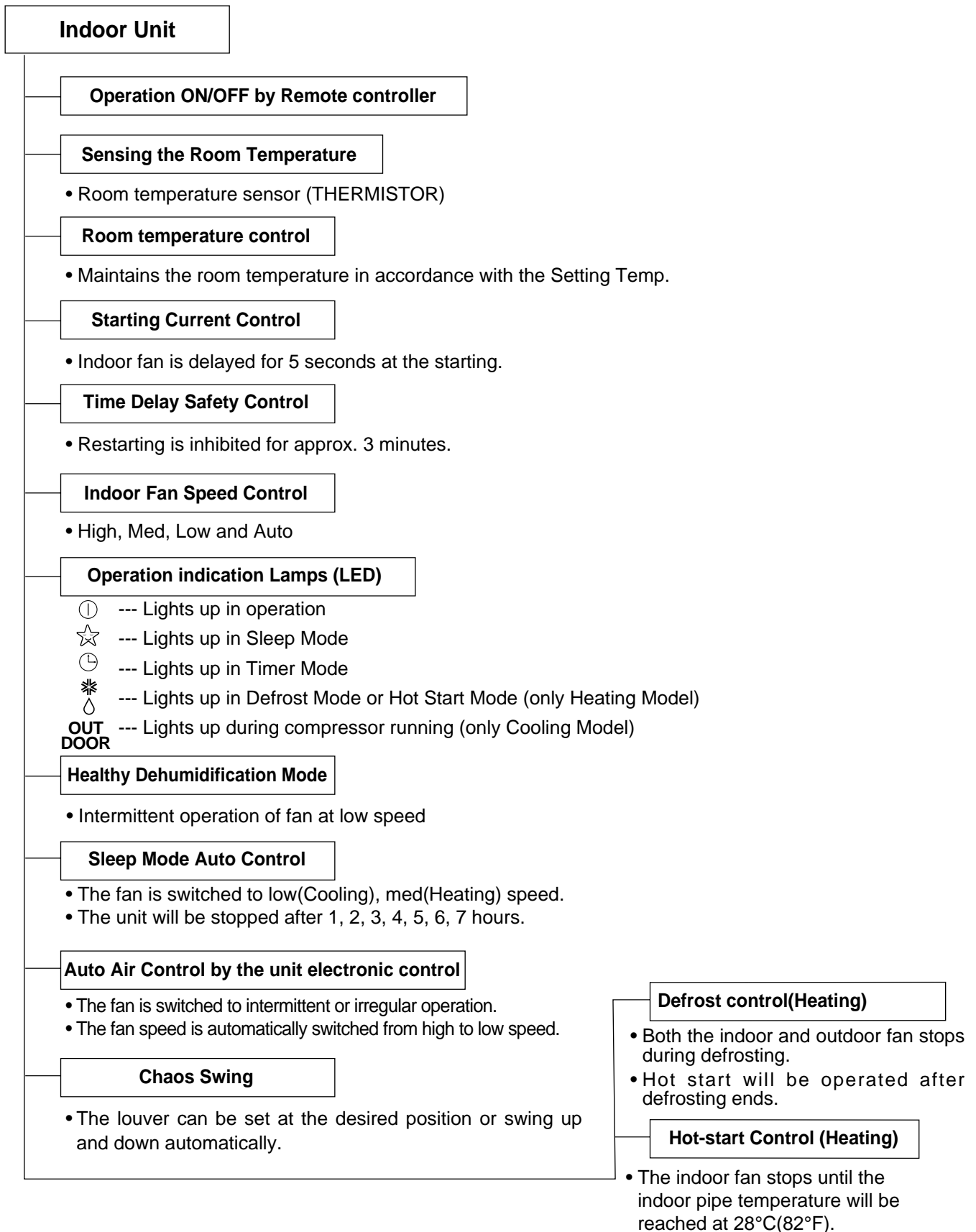

Remote Controller

Operation ON/OFF



Operation Mode Selection



(Cooling model only)



(Heating model only)

Cooling Operation Mode.(*)

Auto Operation Mode.(▲)

Healthy Dehumidification Operation Mode.(◊)

Heating Operation Mode.(☼)

Fan Speed Selection

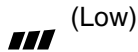

(Low)



(Med)



(High)



(CHAOS)

Room, Temperature Display



(High: 39°C(98°F) ↔ LOW : 12°C(54°F)

Temperature Setting

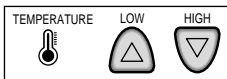

Cooling — [Down to 18°C(64°F) / Up to 30°C(86°F)]

Heating — [Down to 16°C(60°F) / Up to 30°C(86°F)]

JET COOL



Selecting °C / °F



Setting the Time or Timer



Timer Selection

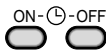

Timer Setting



SET : OFF, ON, OFF ↔ ON

Timer Cancel



CANCEL : Cancel Sleep Mode, Timer ON or Timer OFF

Sleep Operation



: 1, 2, 3, 4, 5, 6, 7, Off Timer

Chaos Swing



Fan Operation Mode



: Fan Operates without cooling or heating.

Horizontal Airflow Direction Control Button(Optional)



Reset

● RESET

Product Specifications(Cooling Only)

Items		Unit	B/A-HMC09AS	B/A-HMC12AS	B/A-HMC18AS	B/A-HMC24AS
Power Supply		ø, V, Hz	1, 115V, 60	1, 115, 60	1, 230/208, 60	1, 230/208, 60
Cooling Capacity		BTU/h	9,000	12,000	18,000/17,800	23,000/22,600
Input		W	940	1,290	1,900/1,870	2,550/2,500
Running Current		A	8.5	11.7	8.5/9.0	11.5/12.0
COMP. Locked Rotor AMP.		A	46	58	47	67
E.E.R		BTU/hW	9.6	9.3	9.5/9.5	9.0/9.0
Air Circulation		m ³ /min(cfm)	7.1(250)	9.4(330)	13(460)	15(530)
Moisture Removal		l/h(pts/hr)	1.2(2.6)	1.4(3)	2.5(5.3)	3.1(6.6)
Noise Level (Sound Pressure, 1m)	Indoor, High	dB(A)	38	41	44	49
	Med	dB(A)	36	39	41	45
	Low	dB(A)	35	37	38	40
	Outdoor, Max	dB(A)	48	48	55	57
Features	Temperature Control		Thermistor	Thermistor	Thermistor	Thermistor
	Air Deflection		4-way	4-way	4-way	4-way
	Steps, Fan/Cool		3/3	3/3	3/3	3/3
	Airflow Direction Control(up&down)		Auto	Auto	Auto	Auto
	Airflow Direction Control(left&right)		Manual	Manual	Manual	Manual
	Remocon Type		Wireless LCD	Wireless LCD	Wireless LCD	Wireless LCD
	Setting Temperature Range, Cooling Mode		64-86°F	64-86°F	64-86°F	64-86°F
	Temperature Increment		2°F	2°F	2°F	2°F
	Auto Operation(electronic control)		Yes	Yes	Yes	Yes
	Self Diagnosis		Yes	Yes	Yes	Yes
	Timer		24hr, On/Off	24hr, On/Off	24hr, On/Off	24hr, On/Off
	Sleep Operation		Yes	Yes	Yes	Yes
	Healthy Dehumidification Mode		Yes	Yes	Yes	Yes
	Restart Delay		minutes	3	3	3
Refrigerant(R-22) Charge		g(oz)	630(22.2)	730(25.8)	1,250(44.1)	2,000(70.5)
Power cord		AWG #: P*mm ²	14:3*2.5	14:3*2.5	14:3*2.5	14:3*2.5
Fuse or breaker Capacity		A	15A	20A	20A	25A
Connecting Cable		AWG #: P*mm ²	16:4*0.75	18:4*0.75	18:4*0.75	18:4*0.75
Connecting Tube (ø. Socket Flare)	Liquid Side	mm(in)	6.35(1/4)	6.35(1/4)	6.35(1/4)	9.52(3/8)
	Gas Side	mm(in)	12.7(1/2)	12.7(1/2)	15.88(5/8)	15.88(5/8)
	Length, std	m(ft)	7.62(25)	7.62(25)	7.62(25)	7.62(25)
Additional Drain Hose(Outer Dia.)		mm(in)	15.5(5/8)	15.5(5/8)	15.5(5/8)	15.5(5/8)
Dimensions (WxHxD)	Indoor	mm	802*262*165	888*287*170	1,080*314*181	1,080*314*181
		in	31.6*10.3*6.5	35.0*11.3*6.7	42.5*12.4*7.1	42.5*12.4*7.1
	Outdoor	mm	770*540*245	770*540*245	870*655*320	870*655*320
		in	30.3*21.3*9.6	30.3*21.3*9.6	34.3*25.8*12.6	34.3*25.8*12.6
Net Weight	Indoor	kg(lbs)	7(15.4)	9.5(20.9)	13(28.7)	13(28.7)
	Outdoor	kg(lbs)	32(70.5)	32(70.5)	61(134.5)	62(136.7)

* Design and Specifications subject to change without prior notice for product improvement.

Product Specifications(Cooling & Heating)

Items		Unit	B/A-HMH12AS	B/A-HMH18AS	B/A-HMH24AS
Power Supply		ø, V, Hz	1, 115, 60	1, 230/208, 60	1, 230/208, 60
Cooling Capacity		BTU/h	12,000	18,000/17,800	23,000/22,600
Heating Capacity		BTU/h	12,000	19,000/18,700	23,000/22,600
Input	Cooling	W	1,290	1,900/1,870	2,550/2,500
	Heating	W	1,290	1,900/1,870	2,550/2,500
Running Current	Cooling	A	11.7	8.5/9.0	11.5/12.0
	Heating	A	11.7	8.5/9.0	11.5/12.0
COMP. Locked Rotor AMP.	Cooling	A	58	42	67
	Heating	A	58	42	67
E.E.R		BTU/hW	9.3	9.5/9.5	9.0/9.0
C.O.P			2.75	2.9/2.9	2.6/2.6
Air Circulation		m ³ /min(cfm)	9.4(330)	13(460)	15(530)
Moisture Removal		l/h(pts/hr)	1.4(3)	2.5(5)	3.1(6.6)
Noise Level (Sound Pressure, 1m)	Indoor, High	dB(A)	41	44	47
	Med	dB(A)	39	41	44
	Low	dB(A)	37	38	40
	Outdoor, Max	dB(A)	48	55	58
Features	Temperature Control		Thermistor	Thermistor	Thermistor
	Air Deflection		4-way	4-way	4-way
	Steps, Fan/Cool/Heat		3/3/3	3/3/3	3/3/3
	Airflow Direction Control(up&down)		Auto	Auto	Auto
	Airflow Direction Control(left&right)		Manual	Manual	Manual
	Remocon Type		Wireless LCD	Wireless LCD	Wireless LCD
	Setting Temperature Range, Cooling Mode		64~86°F	64~86°F	64~86°F
	Heating Mode		60~86°F	60~86°F	60~86°F
	Temperature Increment		2°F	2°F	2°F
	Auto Operation(electronic control)		Yes	Yes	Yes
	Self Diagnosis		Yes	Yes	Yes
	Timer		24hr, On/Off	24hr, On/Off	24hr, On/Off
	Sleep Operation		Yes	Yes	Yes
	Healthy Dehumidification Mode		Yes	Yes	Yes
	Restart Delay	minutes	3	3	3
	Defrost Control		Yes	Yes	Yes
Hot Start		Yes	Yes	Yes	
Refrigerant(R-22) Charge		g(oz)	840(29.6)	1350(47.6)	1900(67.0)
Power cord		AWG #: P*mm ²	14:3*2.5	14:3*2.5	14:3*2.5
Fuse or breaker Capacity		A	20A	20A	25A
Connecting Cable		AWG #: P*mm ²	18:4*0.75	18:4*0.75	18:4*0.75
Connecting Tube (ø. Socket Flare)	Liquid Side	mm(in)	6.35(1/4)	6.35(1/4)	9.52(3/8)
	Gas Side	mm(in)	12.7(1/2)	15.88(5/8)	15.88(5/8)
	Length, std	m(ft)	7.62(25)	7.62(25)	7.62(25)
Additional Drain Hose(Outer Dia.)		mm(in)	15.5(5/8)	15.5(5/8)	15.5(5/8)
Dimensions (WxHxD)	Indoor	mm	888*287*170	1080*314*181	108*314*181
		in	35.0*11.3*6.7	42.5*12.4*7.1	42.5*12.4*7.1
	Outdoor	mm	770*540*245	870*655*320	870*655*320
		in	30.3*21.3*9.6	34.3*25.8*12.6	34.3*25.8*12.6
Net Weight	Indoor	kg(lbs)	9.5(20.9)	13(28.7)	13(28.7)
	Outdoor	kg(lbs)	33(72.8)	62(136.7)	63(138.9)

* Design and Specifications subject to change without prior notice for product improvement.

Dimensions

(1) Indoor Unit

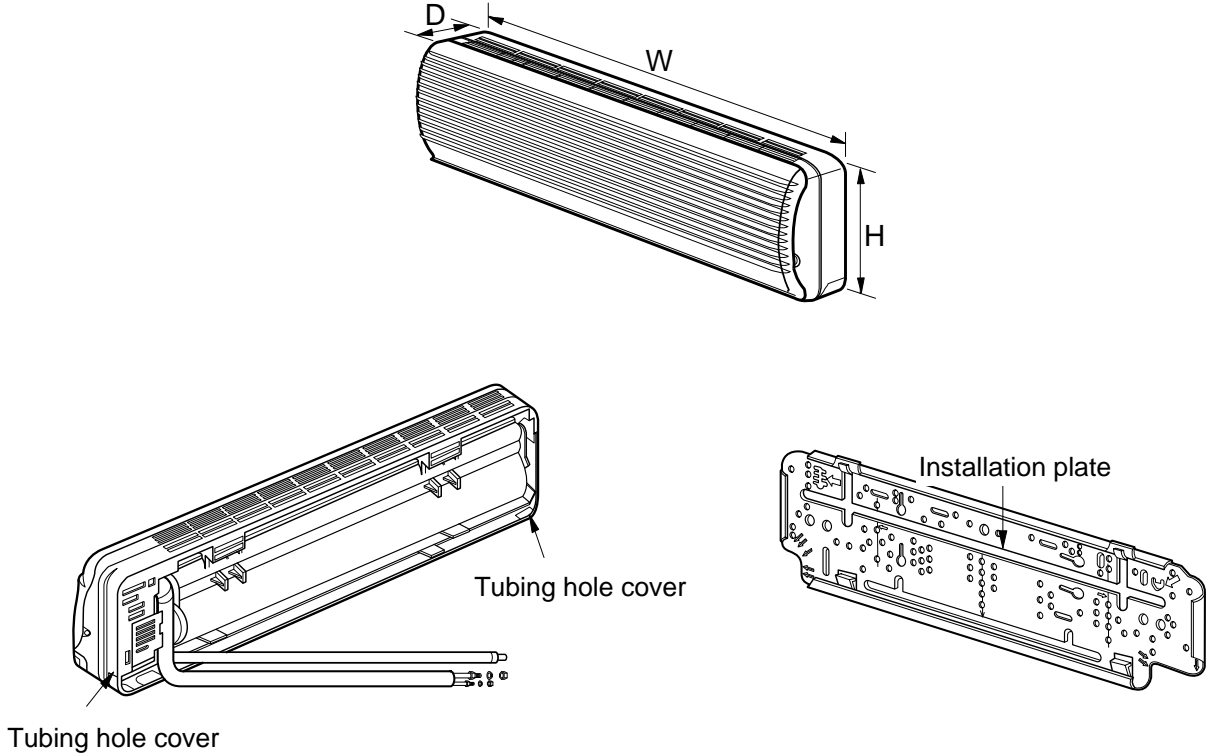

DIM \ MODEL		MODEL		
		9K	12K	18K, 24K
W	mm(inch)	802(31.6")	888(35.0")	1,080(42.5")
H	mm(inch)	262(10.3")	287(11.3")	314(12.4")
D	mm(inch)	165(6.5")	170(6.7")	181(7.1")

(2) Outdoor Unit

1. 9K, 12K

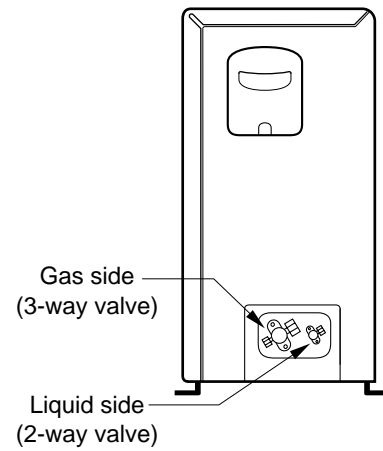
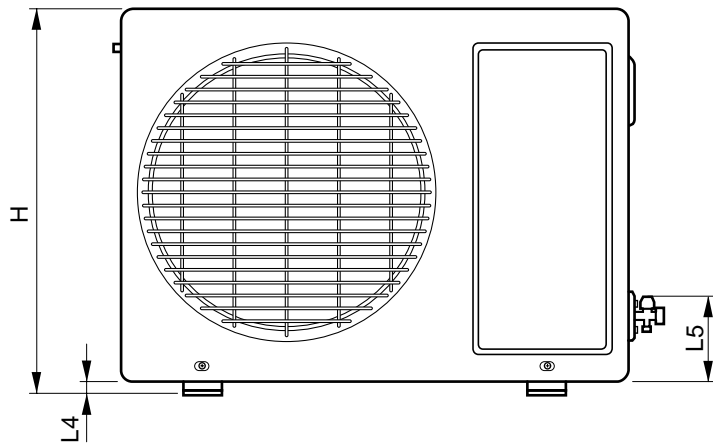
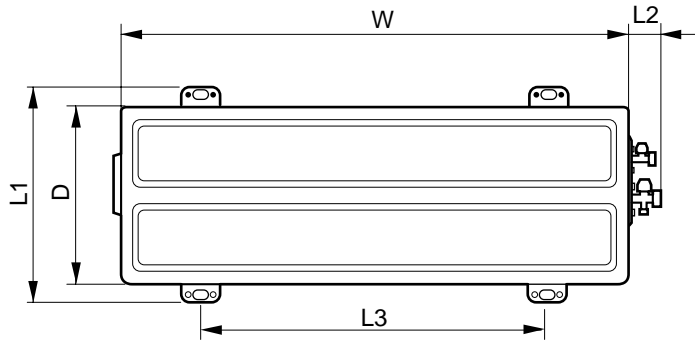

DIM	MODEL	9K, 12K
	unit	
W	mm(inch)	770(30.3)
H	mm(inch)	540(21.3)
D	mm(inch)	245(9.6)
L1	mm(inch)	287(11.3)
L2	mm(inch)	64(2.5)
L3	mm(inch)	518(20.4)
L4	mm(inch)	10(0.4)
L5	mm(inch)	100(3.9)

2. 18K, 24K

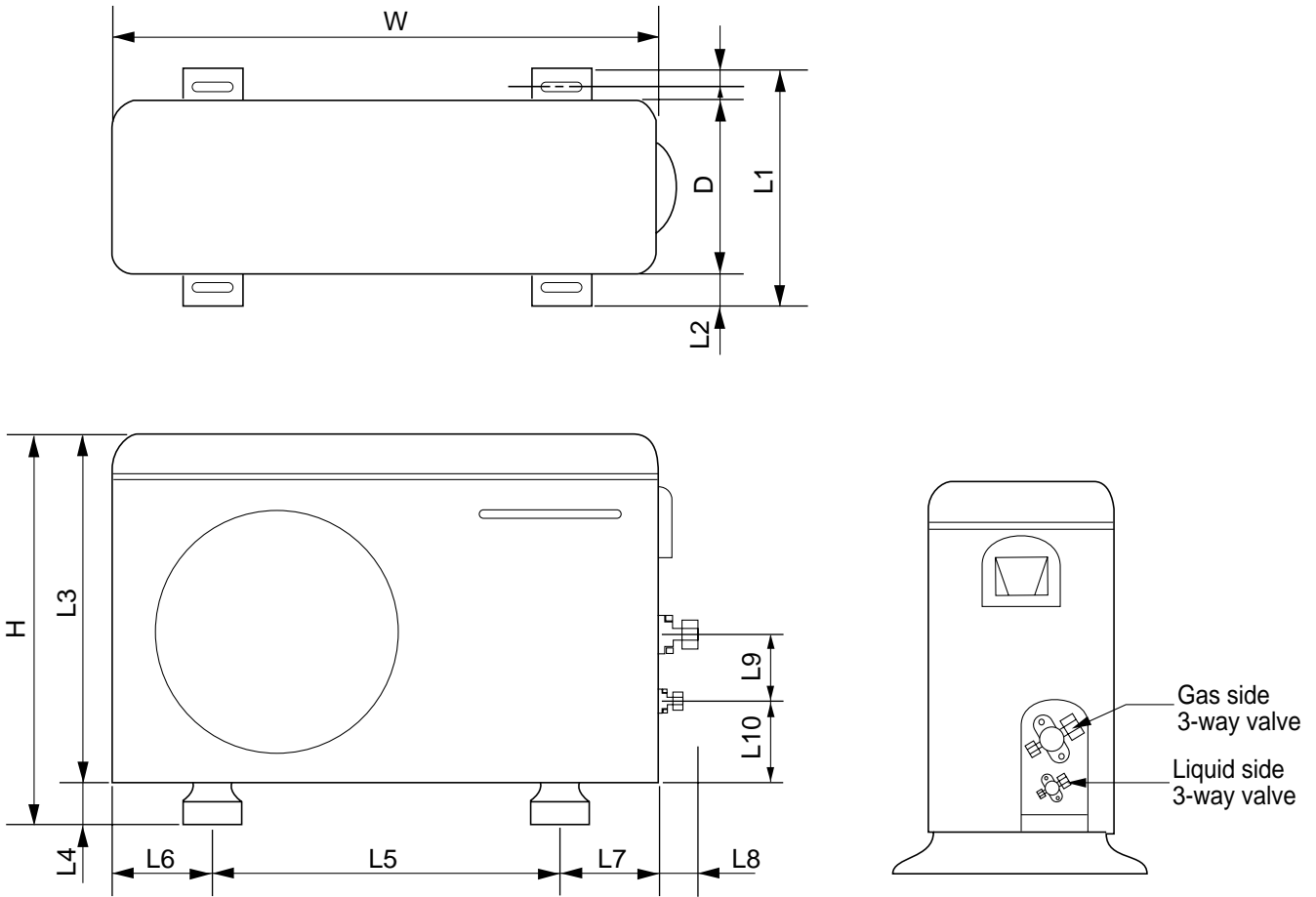

DIM \ MODEL		18K, 24K
W	mm(inch)	870(34.3)
H	mm(inch)	655(25.8)
D	mm(inch)	320(12.6)
L1	mm(inch)	370(14.6)
L2	mm(inch)	25(1.0)
L3	mm(inch)	630(24.8)
L4	mm(inch)	25(1.0)
L5	mm(inch)	546(21.5)
L6	mm(inch)	162(6.4)
L7	mm(inch)	162(6.4)
L8	mm(inch)	54(2.1)
L9	mm(inch)	74.5(2.9)
L10	mm(inch)	79(3.1)

Refrigeration Cycle Diagram

• Cooling Only Models

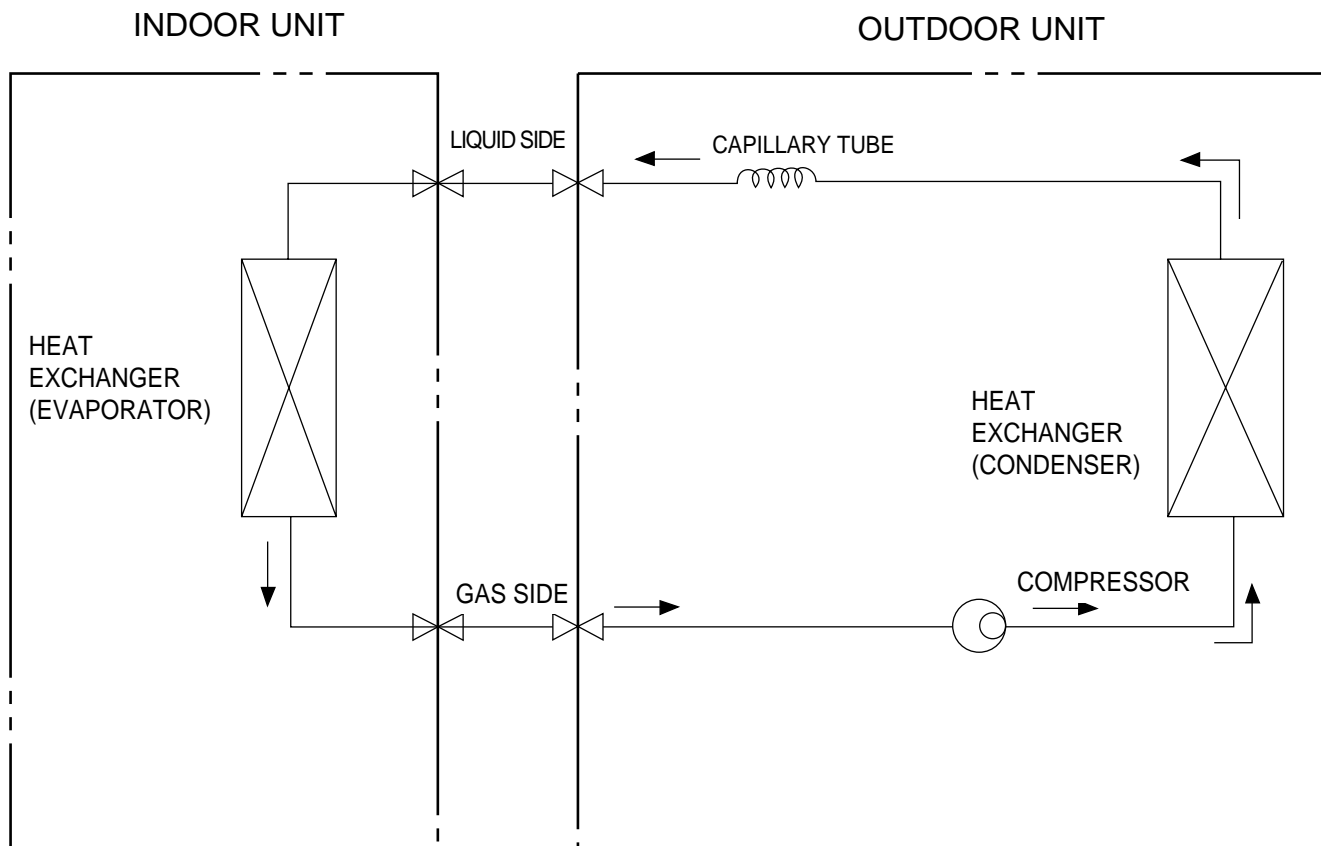

MODEL	Pipe size(Diameter:ø)		Piping length		Elevation	
	Gas	Liquid	Rated	Max	Rated	Max
9K, 12K (Cooling Only)	1/2"	1/4"	7.62m(25ft)	15m(50ft)	5m(16ft)	8m(26ft)
18K (Cooling Only)	5/8"	1/4"	7.62m(25ft)	15m(50ft)	5m(16ft)	8m(26ft)
24K (Cooling Only)	5/8"	3/8"	7.62m(25ft)	15m(50ft)	5m(16ft)	8m(26ft)

For installation over rated, *a proper quantity of refrigerant should be added for each 3.3ft(1m).

a proper quantity of refrigerant	
9k, 12k	0.7 Oz (20g)
18k, 24k	1.4 Oz (40g)

Ex) 18K: When installed at a distance of 50ft(15m), 10.6Oz(295g) of refrigerant should be added.
 $(50-25) \times 1.4 \div 3.3 = 10.6 \text{ Oz (295g)}$ of refrigerant to add

Unit precharged for 25ft. line sets.

• Cooling & Heating Models

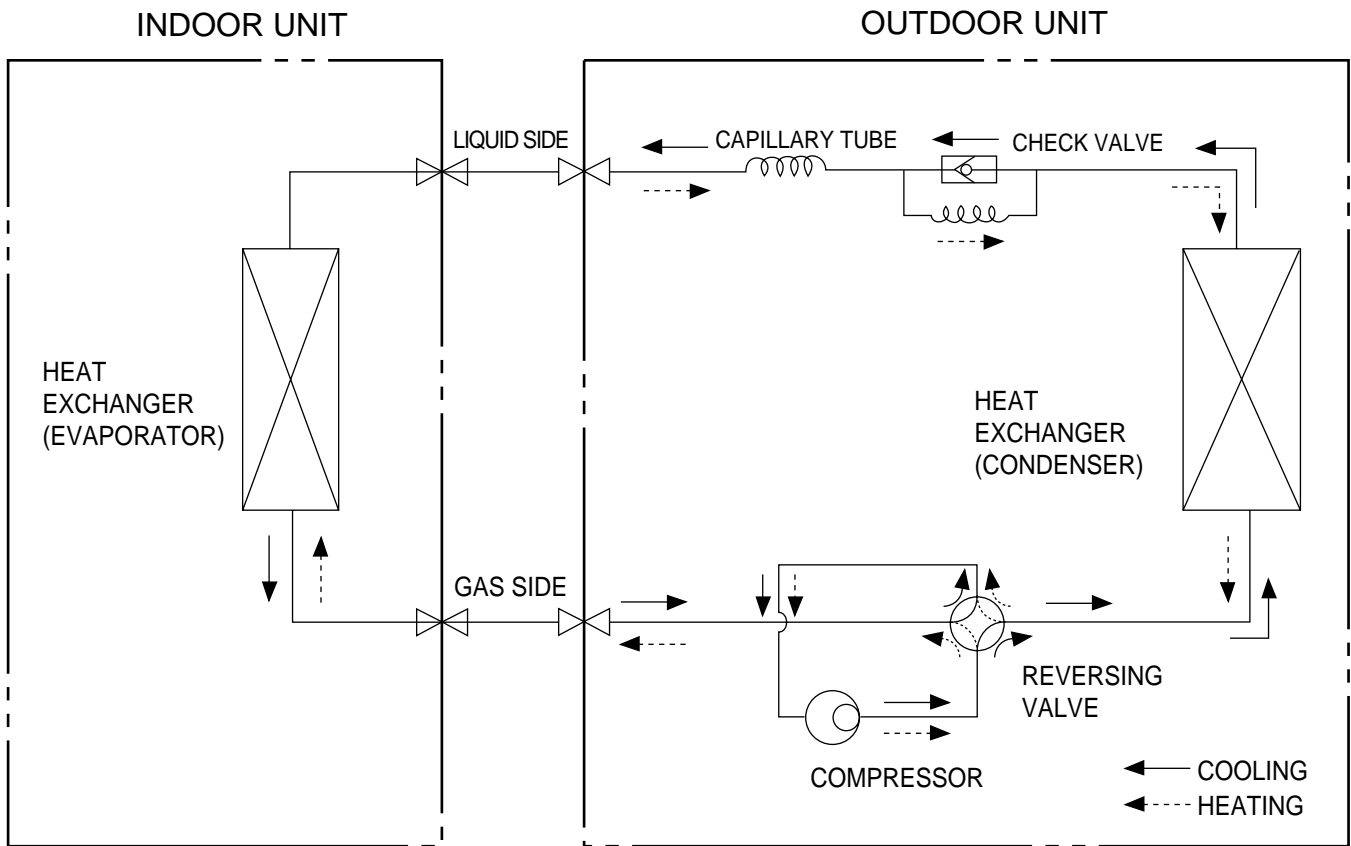

MODEL	Pipe size(Diameter:ø)		Piping length		Elevation	
	Gas	Liquid	Rated	Max	Rated	Max
9K, 12K (Cooling & Heating)	1/2"	1/4"	7.62m(25ft)	15m(50ft)	5m(16ft)	8m(26ft)
18K (Cooling & Heating)	5/8"	1/4"	7.62m(25ft)	15m(50ft)	5m(16ft)	8m(26ft)
24K (Cooling & Heating)	5/8"	3/8"	7.62m(25ft)	15m(50ft)	5m(16ft)	8m(26ft)

For installation over rated, *a proper quantity of refrigerant should be added for each 3.3ft (1m).

a proper quantity of refrigerant	
9k, 12k	0.7 Oz (20g)
18k, 24k	1.4 Oz (40g)

Ex) 18K: When installed at a distance of 50ft(15m), 10.6Oz(295g) of refrigerant should be added.
 $(50-25) \times 1.4 \div 3.3 = 10.6 \text{ Oz (295g)}$ of refrigerant to add

Unit precharged for 25ft. line sets.

Wiring Diagram

(1) Indoor Unit

1. 9K, 12K, 18K, 24K(Cooling Only Models, Cooling & Heating Models)

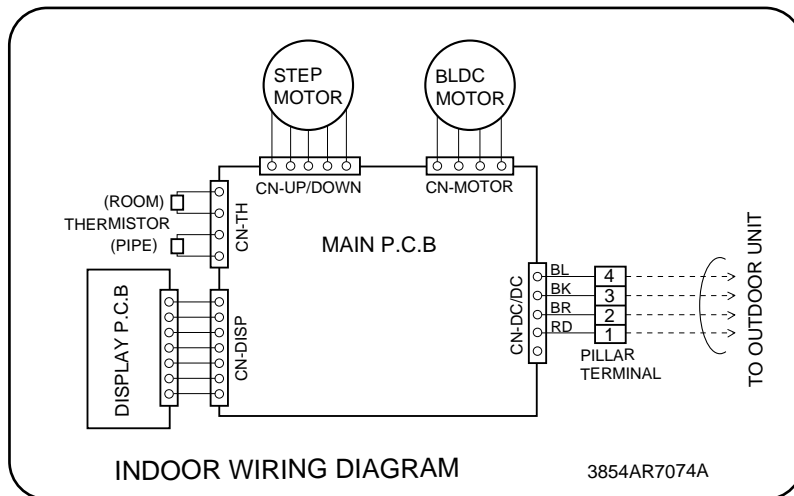

(2) Outdoor Unit

• Cooling Only Models

1. 9K, 12K

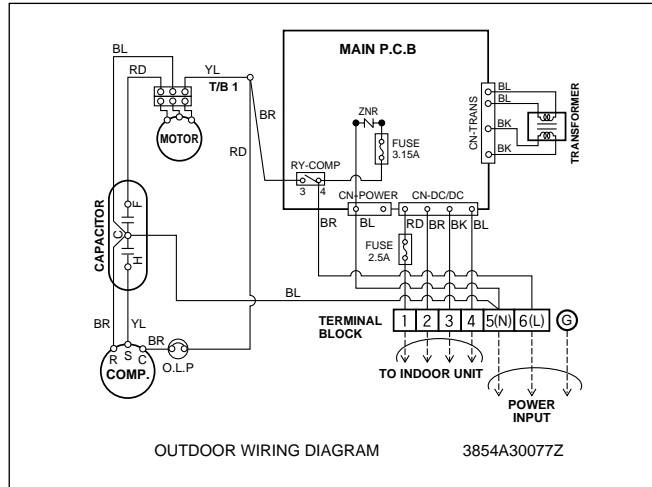

2. 18K

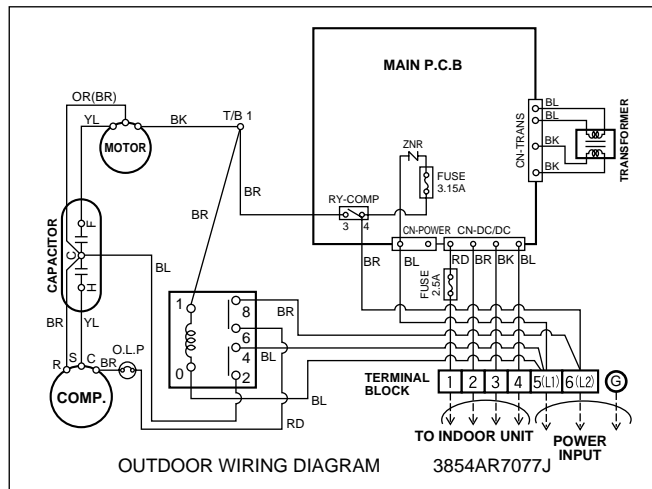

3. 24K

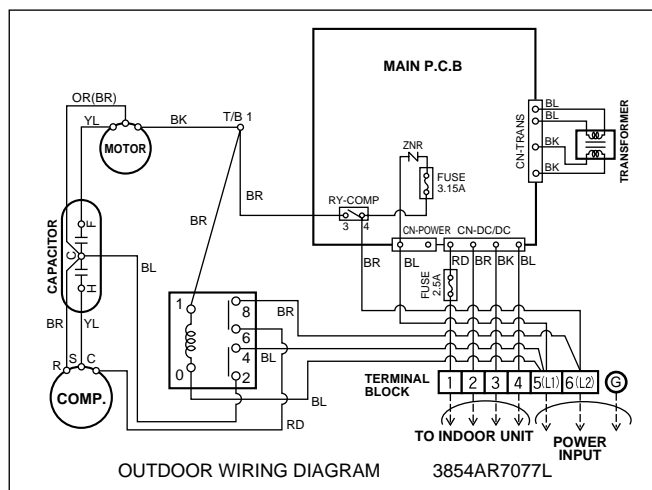

• Cooling & Heating Models

1. 9K, 12K

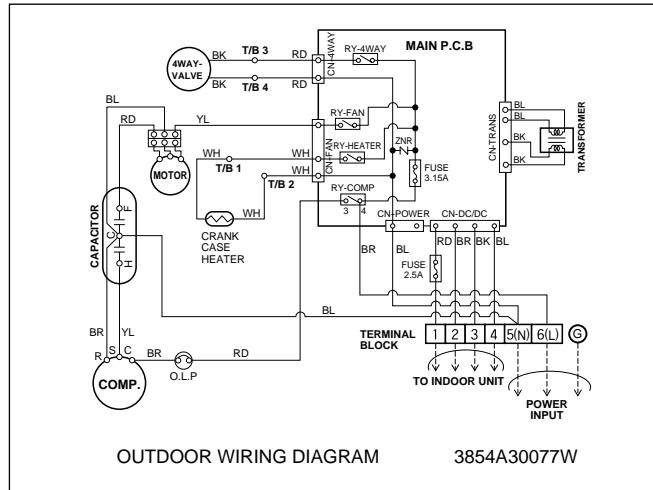

2. 18K, 24K

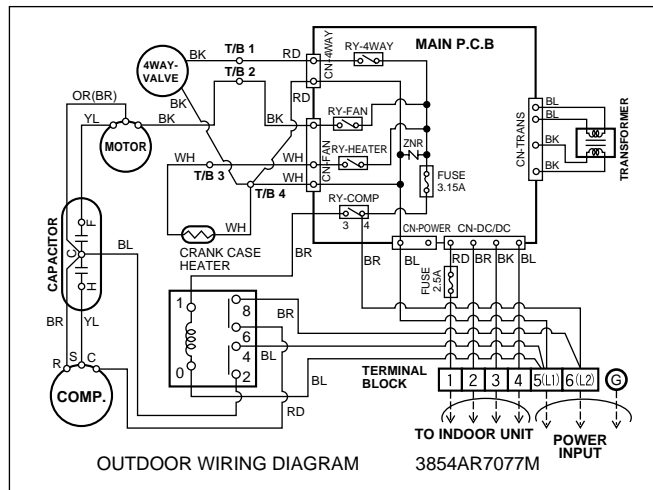

Operation Details

(1) The function of main control

1. Time delay Safety Control

- 3min.; The compressor operation is delayed for 3 minutes to balance the pressure of cycle.
(Protection of compressor)
- 5sec.; The indoor fan is delayed for 5 seconds, when operating initially, to prevent noises occurred by the vertical louver and wind.
- 2min.; The reversing valve is delayed for 2 minutes to prevent the refrigerant-gas for abnormal noise when the heating operation is OFF or switched to the other operation mode while compressor is off.
While compressor is running, it takes 3~5 seconds to switch.

2. Chaos Swing Mode

- By the Chaos Swing key input, the upper/lower vane automatically operates with the Chaos Swing or they are fixed to the desired direction.
- While in Chaos Swing mode, the angles of cooling and heating cycle operations are different.

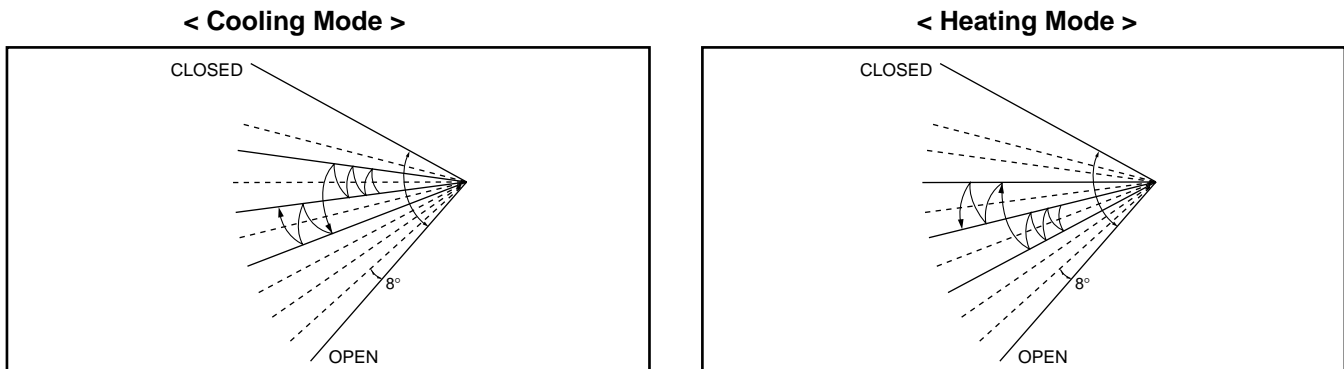

3. Cooling Operation Mode

- When selecting the Cooling(❄) Mode Operation, the unit will operate according to the setting by the remote control and the operation diagram is shown below.

INTAKE AIR TEMP.					
SETTING TEMP. +1°F (Compressor ON)					
SETTING TEMP. -1°F (Compressor OFF)					
INDOOR FAN SPEED	Setting fan speed	Low	Setting fan speed	Low	Setting fan speed
COMPRESSOR	ON	OFF	ON	OFF	ON

■ Protection of the indoor heat exchanger from frosting

- Compressor and outdoor fan stop when indoor pipe temperature is below 0°C(32°F) and restart at the pipe temperature is above 7°C(45°F).

4. Auto Operation (Electronic control mode)

- The operation procedure is shown below. (Cooling & Heating Model)

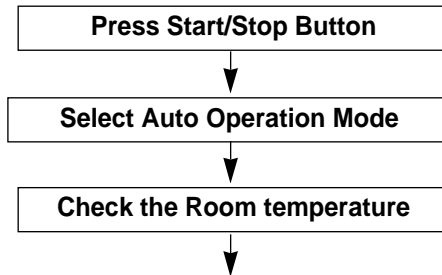

Operation mode Indoor fan speed Setting temperature				are decided automatically by the unit electronic control.
Intake-air temperature	below 70°F	Over 70°F ~ below 76°F	Over 76°F	
Operation Mode	Heating	Soft Dry	Cooling	

* If initial mode is decided, that mode is continued without the room temperature changing.

■ Auto Operation for Cooling

Operation Condition	Intake-air Temperature	Setting Temperature	Fan Speed	Air Direction Control
When Auto Operation initial start	Over 78°F	77°F	Controlled by the electronic control	In this mode, when pressing the vertical air direction control button, vertical louver swings up and down automatically.
	Over 76°F~below 78°F	Intake air -1°C		
	Over 72°F~below 76°F	Intake air -0.5°C		
	Over 68°F~below 72°F	Intake air temperature		
	below 64°F	64°F		
When pressing room temperature setting button during Auto Operation	Over 64°F~below 86°F	Electronic control		
	below 64°F	64°F		
	over 86°F	86°F		

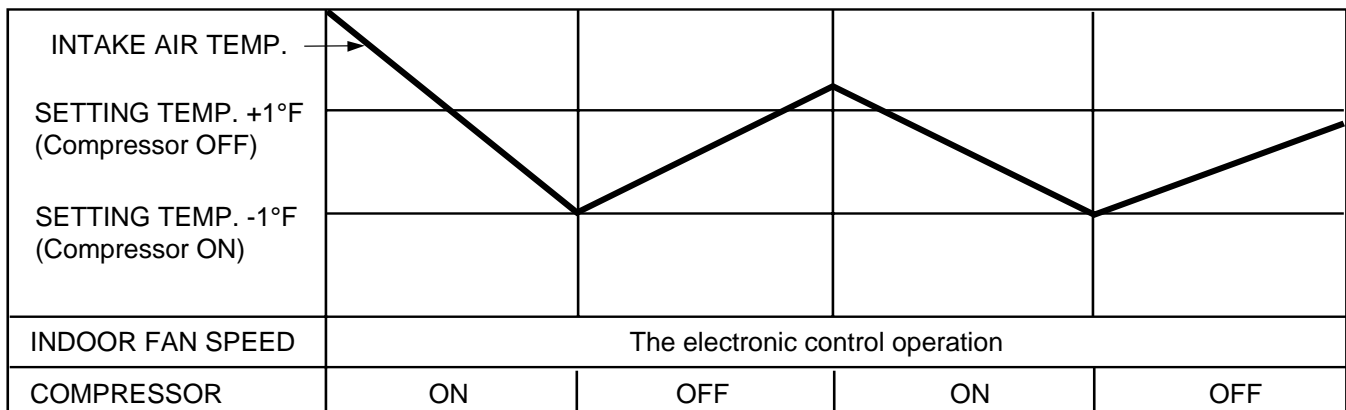

■ **Auto Operation for Dehumidification(only Heating Model)**

- The Setting temperature will be same that of the auto operation for cooling.
- Compressor ON temperature; Setting temperature +2°F
- Compressor OFF temperature; Setting temperature -1°F

Intake-air temp.	below 68°F	Over 68°F~below 70°F	over 86°F
Setting temp.	68°F	Intake air temperature +1°F	86°F

■ **Auto Operation for Heating(only Heating Model)**

- Compressor ON temperature; Setting temperature
- Compressor OFF temperature; Setting temperature +6°F

■ **Vertical louver auto operation** : During Auto Operation, pressing the chaos swing button makes the horizontal louvers swing up and down automatically.
 If you want to stop auto-swing, press chaos swing button again.

5. Healthy Dehumidification

- When the dehumidification operation input by the remote control is received, the intake air temperature is detected and the setting temp is automatically set according to the intake air temperature.
 - 26°C ≤ Intake Air Temp ▶ 25°C
 - 24°C ≤ Intake Intake Air Temp < 26°C ▶ Intake Air Temp - 1°C
 - 18°C ≤ Intake Intake Air Temp < 24°C ▶ Intake Air Temp - 0.5°C
 - Intake Air Temp < 18°C ▶ 18°C
- While in compressor off, the indoor fan repeats low airflow speed and pause.
- While the intake air temp is between compressor on temp. and compressor off temp., 10-min dehumidification operation and 4-min compressor off repeat.
 - Compressor ON Temp. ▶ Setting Temp + 0.5°C
 - Compressor OFF Temp. ▶ Setting Temp - 0.5°C
- In 10-min dehumidification operation, the indoor fan operates with the low airflow speed.

6. Heating Operation Mode(only Heating Model)

The unit will operate according to the setting conditions by the remote controller.
The operation diagram is shown below.

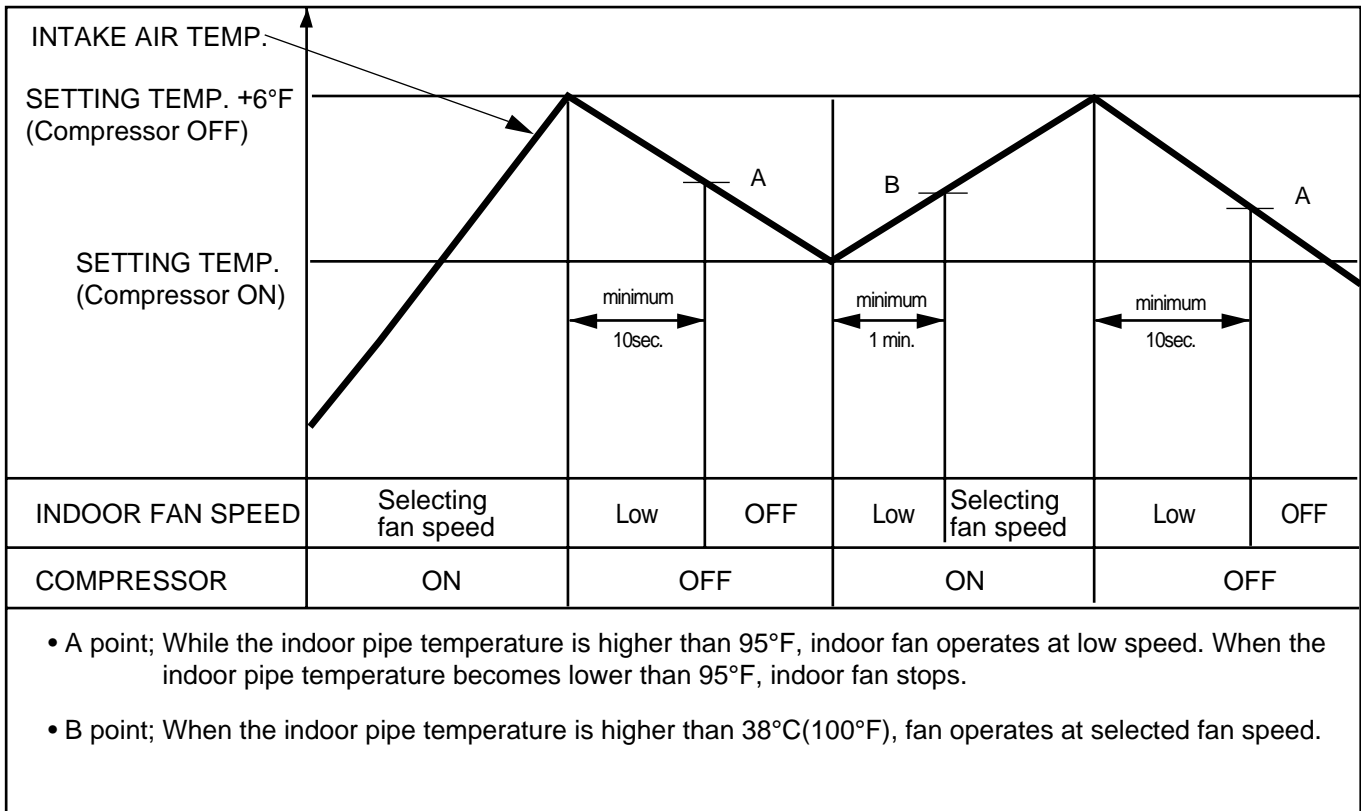

■ Hot-Start Control

- The indoor fan stops until the indoor pipe temperature will be reached at 82°F.
- During heating operation, if indoor pipe temperature falls below 78°F fan stops.
- The operation diagram is shown below.

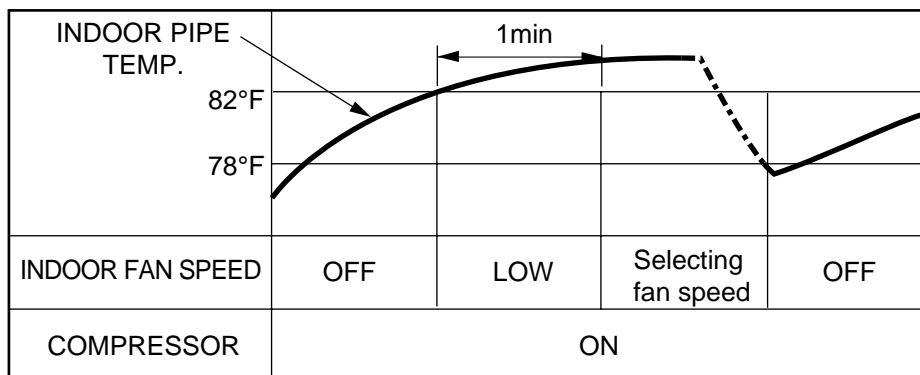

7. Cooling or Heating Mode with Sleep Mode Auto Control

- When selecting the Cooling(※) or the Heating(☼) combined with the Sleep Mode Auto Control(☆), the operation diagram is as following.

■ Cooling Mode with the Sleep Mode

- The setting temperature will be automatically raised by 2°F 30 minutes later and by 4°F 1 hour later.
- The operation will be stopped after 1, 2, 3, 4, 5, 6, 7 hours.

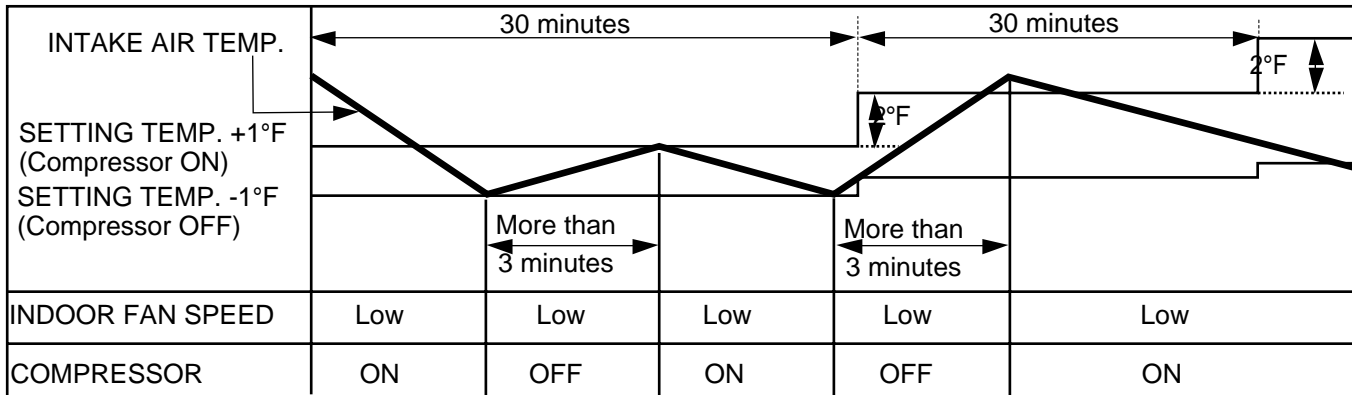

■ Heating Mode with the Sleep Mode(only Heating Model)

- The operation will be stopped after 1, 2, 3, 4, 5, 6, 7 hours.

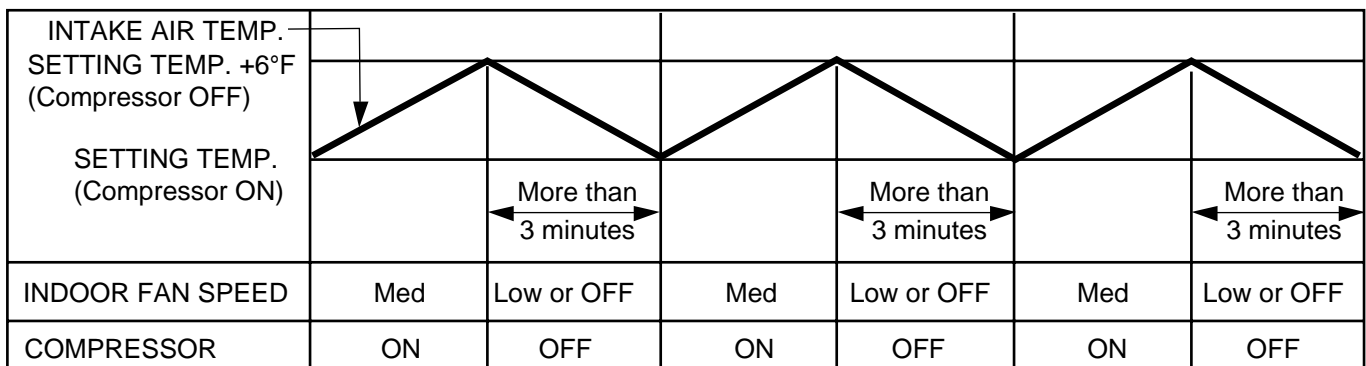

8. Forced Operation

Operation procedures when the remote control can't be used.

Open the front panel upward and move the Slide Switch to the Forced Operation position.

If you want to stop operation, move the Slide Switch to the Auto Restart or the Remote Control position.

In case the power comes on again after power failure on the Forced Operation position, the operating conditions are automatically set as follows:

During Forced Operation, the initial mode continues.

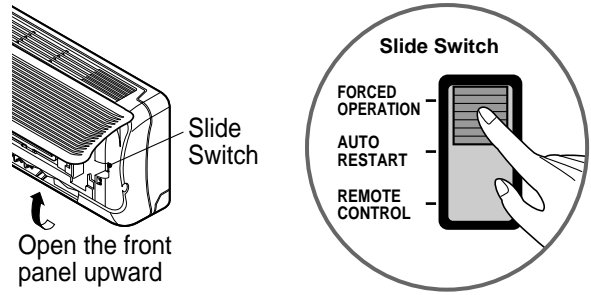

	Cooling Model	Heat pump Model		
		Room Temp. $\geq 24^{\circ}\text{C}(76^{\circ}\text{F})$	$21^{\circ}\text{C}(70^{\circ}\text{F}) \leq \text{Room Temp.} < 24^{\circ}\text{C}(76^{\circ}\text{F})$	Room Temp. $< 21^{\circ}\text{C}(70^{\circ}\text{F})$
Operating mode	Cooling	Cooling	Healthy Dehumidification	Heating
Indoor FAN Speed	High	High	Healthy Dehumidification Rule	High
Setting Temperature	$22^{\circ}\text{C}(72^{\circ}\text{F})$	$22^{\circ}\text{C}(72^{\circ}\text{F})$	$23^{\circ}\text{C}(74^{\circ}\text{F})$	$24^{\circ}\text{C}(76^{\circ}\text{F})$

9. AUTO RESTART

In case the power comes on again after a power failure, Auto Restarting Operation is the function to operate procedures automatically to the previous operating conditions.

If you want to use this operation, Open the front panel upward and move the slide switch to the Auto Restart position.

If you do not want to use this operation, move the Slide Switch to the Remote Control position.

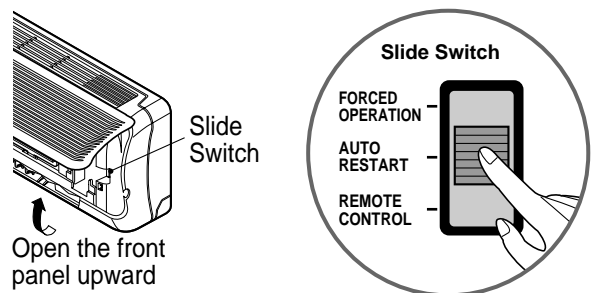

When you are out for a while, put the Slide Switch on the Remote Control.

Display Function

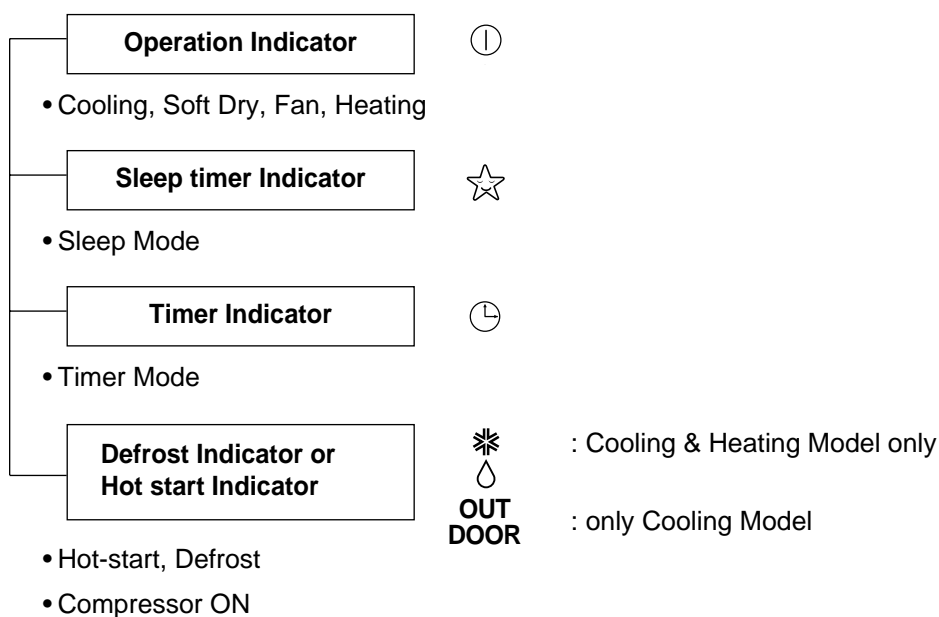

• BUZZER SOUND

- Power Input or Reset : One short beep.
- When Operation Stop Button is pressed : One long beep.
- When Remote Controller Buttons except for Operation Stop are pressed : Two short beep.

Self-diagnosis Function

CODE NO.	DIAGNOSIS	Operation Indicator LED Blinks	Unit Operation
	Indoor room temperature thermistor or pipe temperature thermistor Short/Open	Once	Still Operation
	Outdoor pipe thermistor Short/Open	Twice	Outdoor Unit Off
	Communication failure between indoor and outdoor	5 times	Stop

- LED blinks as many times as code No. (0.5 second ON/0.5 second OFF) with 3 seconds interval.
- While the unit is off, no indication displays.
- If more than one code occurs simultaneously, bigger code No. is displayed.

Installation

IMPORTANT!

Please read this instruction sheet completely before installing the product.

This air conditioning system meets strict safety and operating standards. As the installer or service person, it is an important part of your job to install or service the system so it operates safely and efficiently.

WARNING

- Installation or repairs made by unqualified persons can result in hazards to you and others. Installation MUST conform with local building codes or, in the absence of local codes, with the National Electrical Code NFPA 70/ANSI C1-1993 or current edition and Canadian Electrical Code Part 1 CSA C.22.1.
- The information contained in the manual is intended for use by a qualified service technician familiar with safety procedures and equipped with the proper tools and test instruments.
- Failure to carefully read and follow all instructions in this manual can result in equipment malfunction, property damage, personal injury and/or death.

CAUTION: Improper installation, adjustment, alteration, service or maintenance can void the warranty.

The weight of the condensing unit requires caution and proper handling procedures when lifting or moving to avoid personal injury. Use care to avoid contact with sharp or pointed edges.

Safety Precautions

- Always wear safety eye wear and work gloves when installing equipment.
- Never assume electrical power is disconnected. Check with meter and equipment.
- Keep hands out of fan areas when power is connected to equipment.
- R-22 causes frostbite burns.
- R-22 is toxic when burned.

NOTE TO INSTALLING DEALER: The Owners Instructions and Warranty are to be given to the owner or prominently displayed near the indoor Furnace/Air Handler Unit.

Special warnings

When wiring:

Electrical shock can cause severe personal injury or death. Only a qualified, experienced electrician should attempt to wire this system.

- Do not supply power to the unit until all wiring and tubing are completed or reconnected and checked.
- Highly dangerous electrical voltages are used in this system. Carefully refer to the wiring diagram and these instructions when wiring. Improper connections and inadequate grounding can cause accidental injury or death.
- Ground the unit following local electrical codes.
- Connect all wiring tightly. Loose wiring may cause overheating at connection points and a possible fire hazard.

When transporting:

Be careful when picking up and moving the indoor and outdoor units. Get a partner to help, and bend your knees when lifting to reduce strain on your back. Sharp edges or thin aluminum fins on the air conditioner can cut your finger.

When installing...

... **in a wall:** Make sure the wall is strong enough to hold the unit's weight.

It may be necessary to construct a strong wood or metal frame to provide added support.

... **in a room:** Properly insulate any tubing run inside a room to prevent "sweating" that can cause dripping and water damage to wall and floors.

... **in moist or uneven locations:** Use a raised concrete pad or concrete blocks provide a solid, level foundation for the outdoor unit. This prevents water damage and abnormal vibration.

... **in an area with high winds:** Securely anchor the outdoor unit down with bolts and a metal frame. Provide a suitable air baffle.

... **in a snowy area(for Heat Pump Model):** Install the outdoor unit on a raised platform that is higher than drifting snow. Provide snow vents.

When connecting refrigerant tubing

- Keep all tubing runs as short as possible.
- Use the flare method for connecting tubing.
- Check carefully for leaks before starting the test run.

When servicing

- Turn the power OFF at the main power box(mains) before opening the unit to check or repair electrical parts and wiring.
- Keep your fingers and clothing away from any moving parts.
- Clean up the site after you finish, remembering to check that no metal scraps or bits of wiring have been left inside the unit being serviced.

(1) Installation Parts Provided

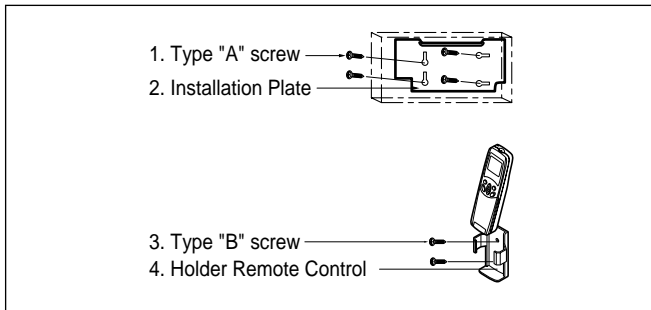

(2) Installation of indoor, outdoor unit

Read completely, then follow step by step.

1) Select the best location

1. Indoor unit

- Do not have any heat or steam near the unit.
- Select a place where there are no obstacles in front of the unit.
- Make sure that condensation drainage can be conveniently routed away.
- Do not install near a doorway.
- Ensure that the space around the left and right of the unit is more than 5cm(2"). The unit should be installed as high on the wall as possible, allowing a minimum of 5cm(2") from ceiling.
- Use a stud finder to locate studs to prevent unnecessary damage to the wall.

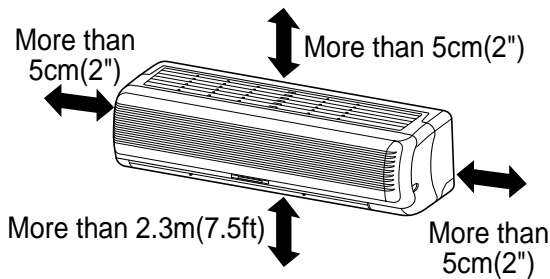

CAUTION

Install the indoor unit on the wall where the height from the floors more than 2.3 meters(7.5ft).

2. Outdoor unit

- If an awning is built over the unit to prevent direct sunlight or rain exposure, make sure that heat radiation from the condenser is not restricted.
- Ensure that the space around the back and sides is more than 10cm. The front of the unit should have more than 70cm of space.
- Do not place animals and plants in the path of the warm air.
- Take the air conditioner weight into account and select a place where noise and vibration are minimum.
- Select a place so that the warm air and noise from the air conditioner do not disturb neighbors.

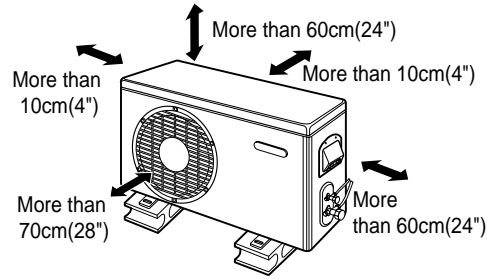

■ Rooftop Installations:

If the outdoor unit is installed on a roof structure, be sure to level the unit. Ensure the roof structure and anchoring method are adequate for the unit location. Consult local codes regarding rooftop mounting.

2) Piping length and elevation

MODEL (Cooling Capa.)	Pipe Size		Max length A	Max Elevation B
	GAS	LIQUID		
9K, 12K	1/2"	1/4"	15m(50ft)	8m(26ft)
18K	5/8"	1/4"	15m(50ft)	8m(26ft)
24K	5/8"	3/8"	15m(50ft)	8m(26ft)

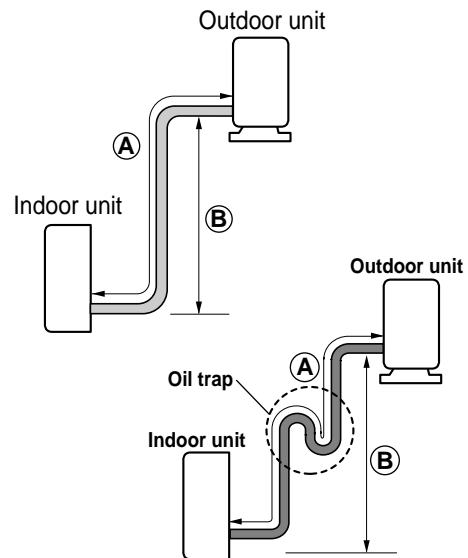

In case more than 5m(16.4ft)

CAUTION

- Capacity is based on standard length and maximum allowance length is on the basis of reliability.
- Oil trap should be installed every 5~7 meters(16.4~23ft).

3) How to fix installation plate

The wall you select should be strong and solid enough to prevent vibration

1. Mount the installation plate on the wall with four type A screws. If mounting the unit on a concrete wall, use anchor bolts.

■ Mount the installation plate horizontally by aligning the centerline using a level.

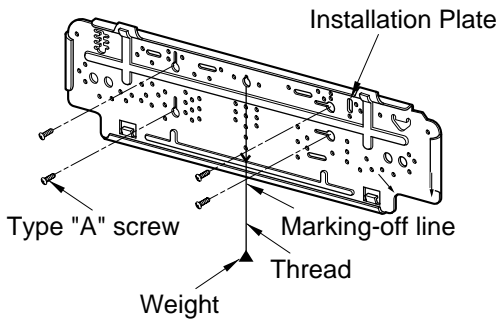

2. Measure the wall and mark the centerline. It is also important to use caution concerning the location of the installation plate—routing of the wiring to power outlets is through the walls typically. Drilling the hole through the wall for piping connections must be done safely.

18, 24K Btu

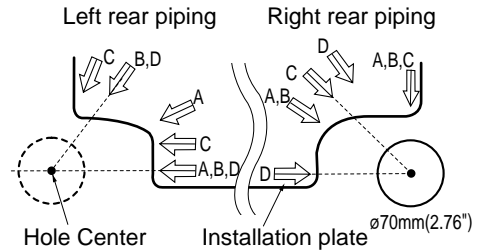

■ For right rear piping and left rear piping, draw a line in the direction of the arrow marked "A". The meeting point of the two lines is the center of the hole.

• The position of the center of the hole.

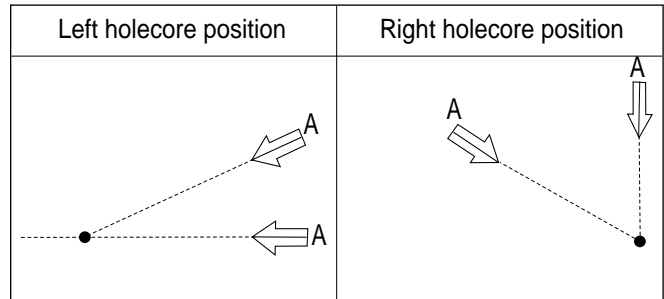

9K Btu

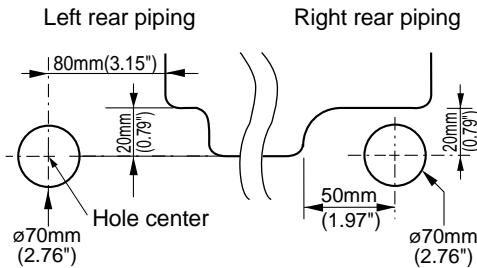

12K Btu

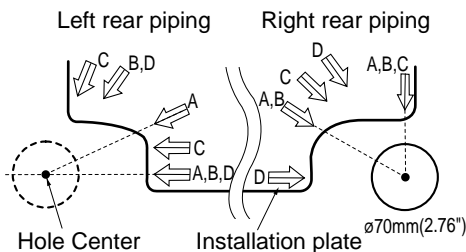

4) Drill a hole in the wall

■ Drill the piping hole with a $\varnothing 70\text{mm}$ (0.76") hole core drill. Drill the piping hole at either the right or the left with the hole slightly slanted to the outdoor side.

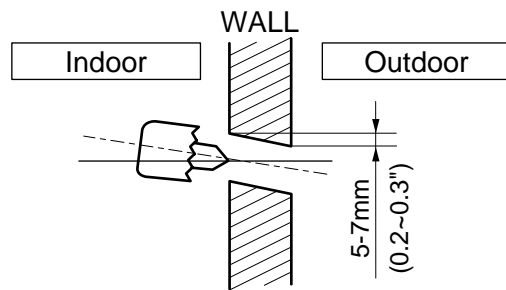

(3) Flaring work and connection of piping

1) Flaring work

Main cause for gas leakage is due to defect in flaring work. Carry out correct flaring work in the following procedure.

1. Cut the pipes and the cable.

- Use the piping kit accessory or the pipes purchased locally.
- Measure the distance between the indoor and the outdoor unit.
- Cut the pipes a little longer than measured distance.
- Cut the cable 1.5m(4.9ft) longer than the pipe length.

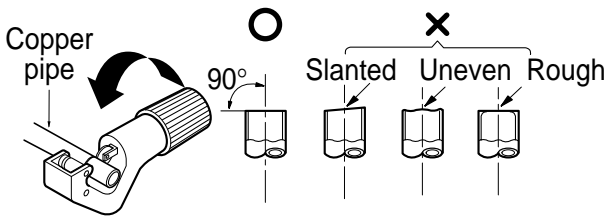

2. Burrs removal

- Completely remove all burrs from the cut cross section of pipe/tube.
- Put the end of the copper tube/pipe in a downward direction as you remove burrs in order to avoid dropping burrs into the tubing.

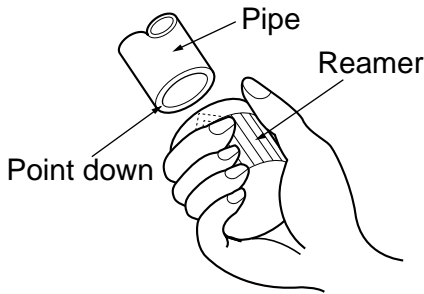

3. Putting nut on

- Remove flare nuts attached to indoor and outdoor unit, then put them on pipe/tube having completed burr removal. (not possible to put them on after flaring work)

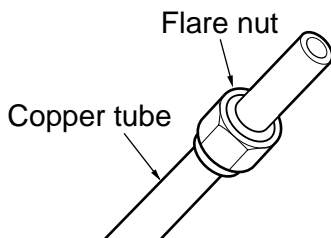

4. Flaring work

- Carry out flaring work using flaring tool as shown below.

Outside diameter		A
mm	inch	mm
ø6.35	1/4	0~0.5
ø9.52	3/8	0~0.5
ø12.7	1/2	0~0.5
ø15.88	5/8	0~1.0

Firmly hold copper pipe in a die in the dimension shown in the table above.

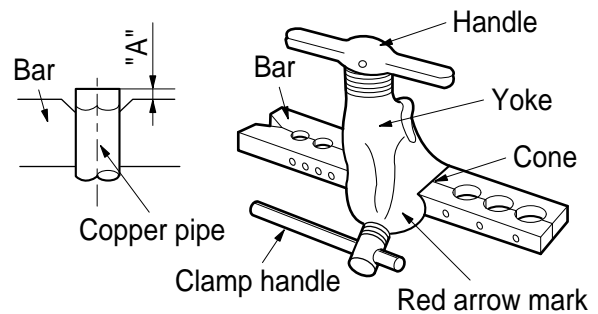

5. Check

- Compare the flared work with figure below.
- If flare is noted to be defective, cut off the flared section and do flaring work again.

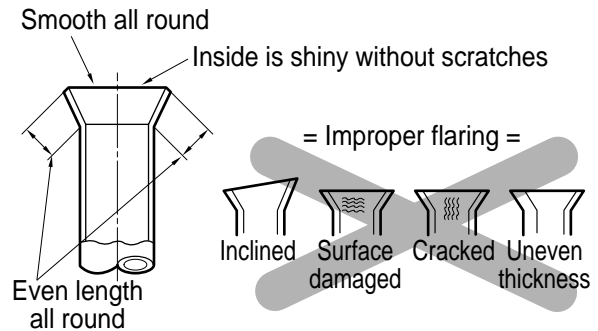

2) Connection of piping --Indoor

- Preparing the indoor unit's piping and drain hose for installation through the wall.
- Remove the plastic tubing retainer(see illustration below) and pull the tubing and drain hose away from chassis.
- Replace the plastic tubing holder in the original position.

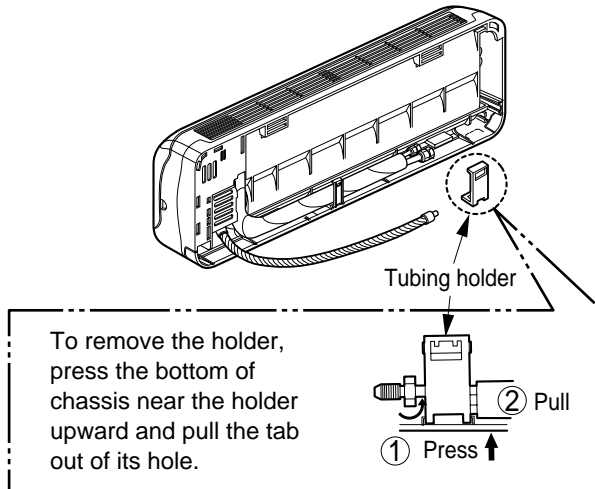

CAUTION

When install, make sure that the remaining parts must be removed clearly so as not to damage the piping and drain hose, especially connecting cable.

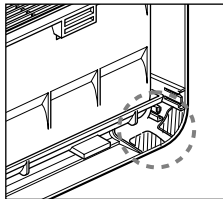

For left rear piping

1. Route the indoor tubing and the drain hose in the direction of rear left.

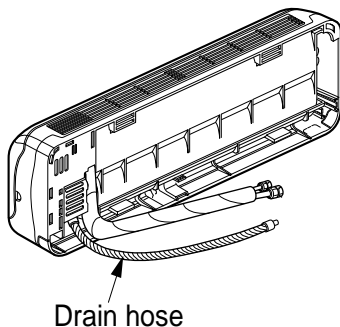

2. Insert the connecting cable into the indoor unit from the outdoor unit through the piping hole.

- Do not connect the cable to the indoor unit.
- Make a small loop with the cable for easy connection later.

3. Tape the tubing, drain hose and the connecting cable. Be sure that the drain hose is located at the lowest side of the bundle. Locating at the upper side can cause drain pan to overflow inside the unit.

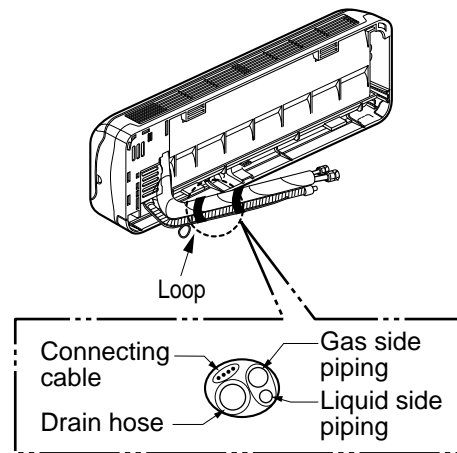

NOTE: If the drain hose is routed inside the room, insulate the hose with an insulation material* so that dripping from "sweating"(condensation) will not damage furniture or floors.
*Foamed polyethylene or equivalent is recommended.

4. Indoor unit installation

- Hook the indoor unit onto the upper portion of the installation plate.(Engage the two hooks of the rear top of the indoor unit with the upper edge of the installation plate.) Ensure that the hooks are properly seated on the installation plate by moving it left and right.

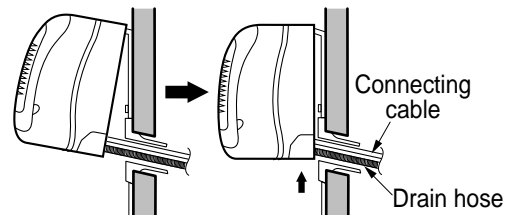

Press the lower left and right sides of the unit against the installation plate until the hooks engage into their slots(clicking sound).

5. Connecting the pipings to the indoor unit and drain hose to drain pipe.

- Align the center of the pipings and sufficiently tighten the flare nut by hand.

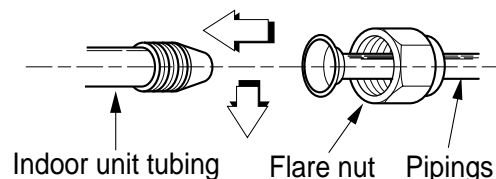

- Tighten the flare nut with a wrench.

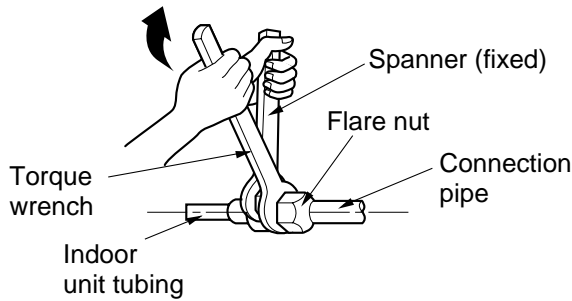

Capacity (Btu/h)	Pipe Size[Torque]	
	GAS	LIQUID
9K	1/2"[5.5kg.m]	1/4"[1.8kg.m]
12K	1/2"[5.5kg.m]	1/4"[1.8kg.m]
18K	5/8"[6.6kg.m]	1/4"[1.8kg.m]
24K	5/8"[6.6kg.m]	3/8"[4.2kg.m]

- When extending the drain hose at the indoor unit, install the drain pipe.

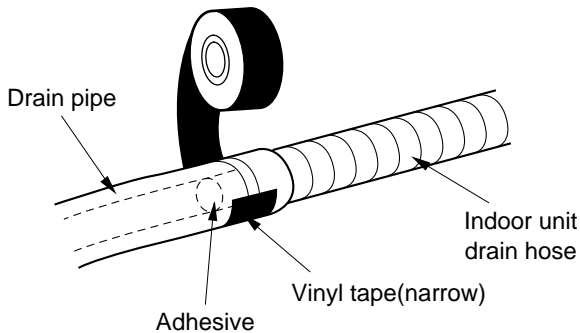

6. Wrap the insulation material around the connecting portion.

- Overlap the connection pipe insulation material and the indoor unit pipe insulation material. Bind them together with vinyl tape so that there is no gap.

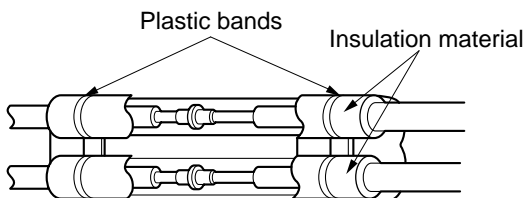

- Wrap the area which accommodates the rear piping housing section with vinyl tape.

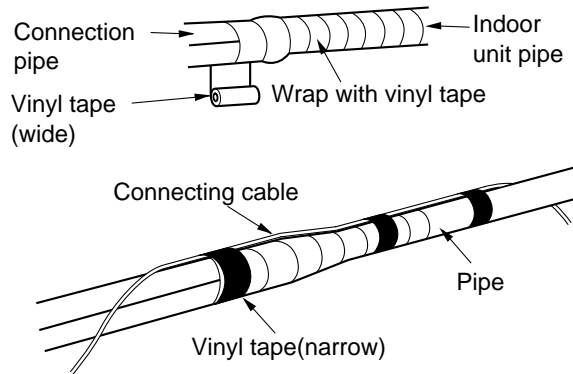

- Bundle the piping and drain hose together by wrapping them with vinyl tape over the range within which they fit into the rear piping housing section.

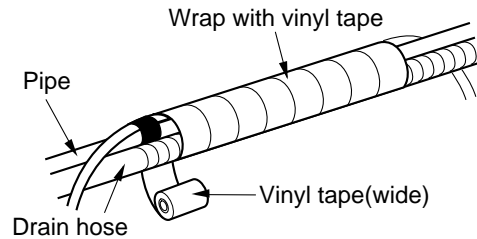

For right rear piping

1. Route the indoor tubing and the drain hose to the required piping hole position.

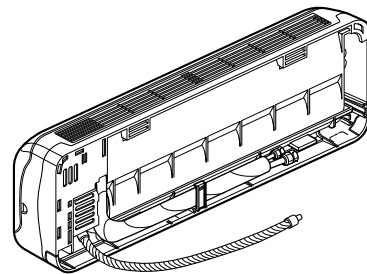

2. Insert the piping, drain hose and the connecting cable into the piping hole.

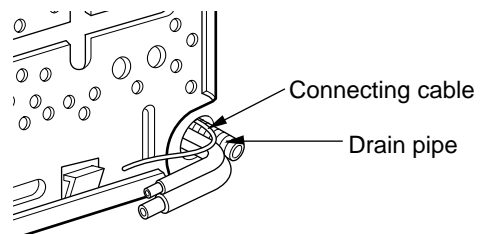

3. Insert the connecting cable into the indoor unit.

- Don't connect the cable to the indoor unit.
- Make a small loop with the cable for easy connection later.

4. Tape the drain hose and the connecting cable.

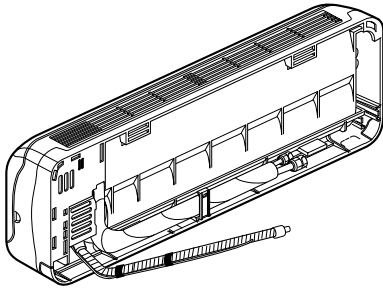

5. Indoor unit installation

- Hang the indoor unit from the hooks at the top of the installation plate.
- Insert the spacer etc. between the indoor unit and the installation plate and separate the bottom of the indoor unit from the wall.

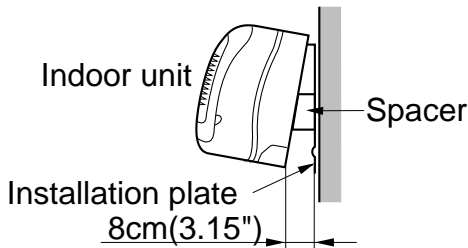

6. Connecting the pipings to the indoor unit and the drain hose to drain pipe.

- Align the center of the pipings and sufficiently tighten the flare nut by hand.

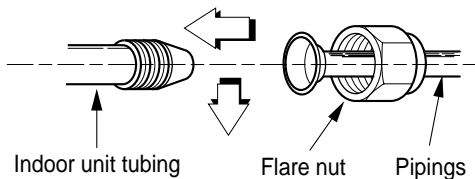

- Tighten the flare nut with a wrench.

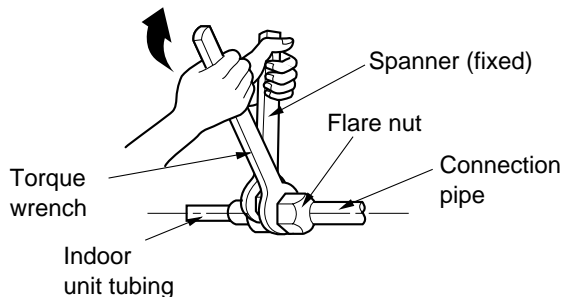

Capacity (Btu/h)	Pipe Size[Torque]	
	GAS	LIQUID
9K	1/2"[5.5kg.m]	1/4"[1.8kg.m]
12K	1/2"[5.5kg.m]	1/4"[1.8kg.m]
18K	5/8"[6.6kg.m]	1/4"[1.8kg.m]
24K	5/8"[6.6kg.m]	3/8"[4.2kg.m]

- When extending the drain hose at the indoor unit, install the drain pipe.

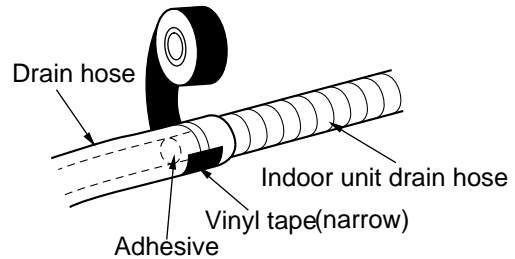

7. Wrap the insulation material around the connecting portion.

- Overlap the connection pipe heat insulation and the indoor unit pipe heat insulation material. Bind them together with vinyl tape so that there is no gap.

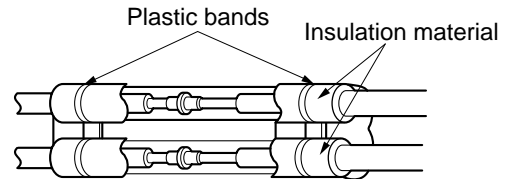

- Wrap the area which accommodates the rear piping housing section with vinyl tape.

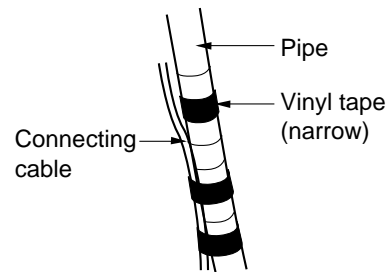
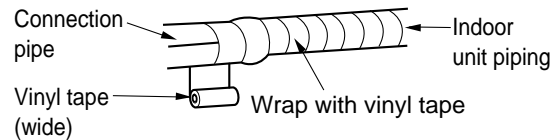

- Bundle the piping and drain hose together by wrapping them with cloth tape over the range within which they fit into the rear piping housing section.

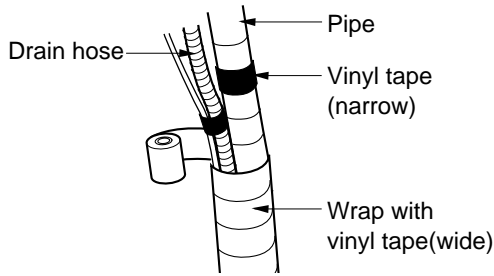

8. Reroute the pipings and the drain hose across the back of the chassis.

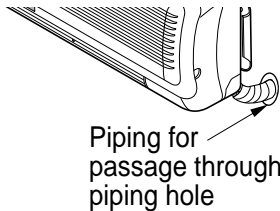

9. Set the pipings and the drain hose to the back of the chassis with the tubing holder.

- Hook the edge of tubing holder to tap on chassis and push the bottom of tubing holder to be engaged at the bottom of chassis.

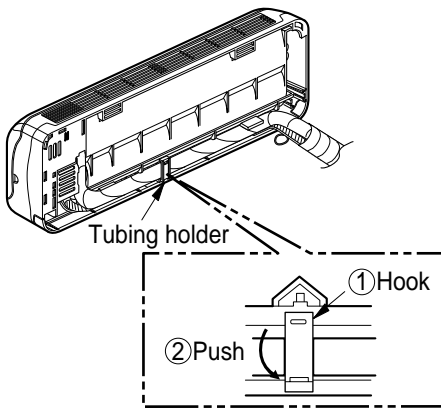

10. Indoor unit installation

- Remove the spacer.
- Ensure that the hooks are properly seated on the installation plate by moving it left and right.

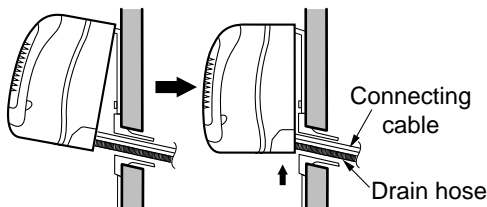

Press the lower left and right sides of the unit against the installation plate until the hooks engage into their slots (clicking sound).

3) Connection of the pipes-Outdoor

1. Align the center of the pipings and sufficiently tighten the flare nut by hand

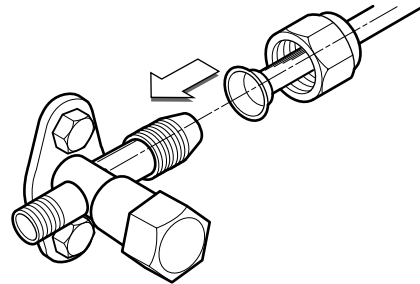

2. Finally, tighten the flare nut with torque wrench until the wrench clicks.

- When tightening the flare nut with torque wrench, ensure the direction for tightening follows the arrow on the wrench.

Capacity (Btu/h)	Pipe Size[Torque]	
	GAS	LIQUID
9K	1/2"[5.5kg.m]	1/4"[1.8kg.m]
12K	1/2"[5.5kg.m]	1/4"[1.8kg.m]
18K	5/8"[6.6kg.m]	1/4"[1.8kg.m]
24K	5/8"[6.6kg.m]	3/8"[4.2kg.m]

Outdoor unit

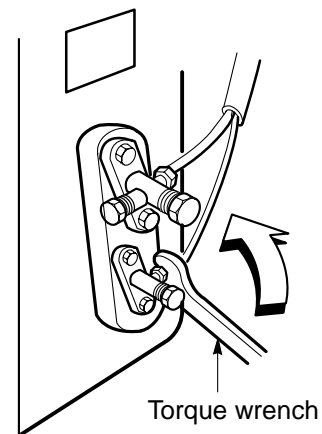

(4) Connecting the cable between indoor unit and outdoor unit

1. Remove the cover control from the unit by loosening the 3 screws.
2. Dismount caps on the conduit panel.
3. Temporarily mount the conduit tubes on the conduit panel.
4. Properly connect both the power supply and low voltage lines to the corresponding terminals on the terminal block.
5. Ground the unit in accordance with local codes.
6. Be sure to size each wire allowing several inches longer than the required length for wiring.
7. Use lock nuts to secure the conduit tubes.

NOTE

Connector trade size for this unit is 1/2". Refer to "How to connect wiring to the terminals" for instructions on connecting depending on the wire type you are using.



WARNING

- Be sure to comply with local codes while running the wire from the indoor unit to the outdoor unit (size of wire and wiring method, etc).
- Every wire must be connected firmly.
- No wire should be allowed to touch refrigerant tubing, the compressor or any moving parts.

Power Supply

Model	Power source	AWG(MIN.)		Fuse or breaker Capacity
		Ⓐ	Ⓑ	
9K	1ø, 115V	14	18	15A
12K	1ø, 115V	14	18	20A
18K	1ø, 230/208V	14	18	20A
24K	1ø, 230/208V	12	18	25A

Wiring Diagram

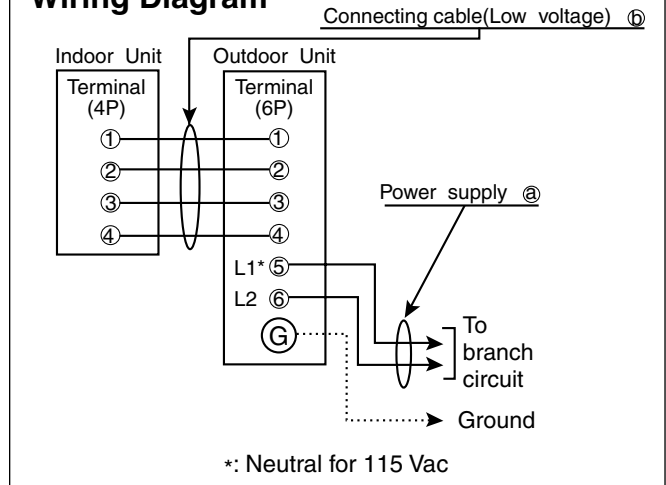

NOTE

1. shows field wiring.
2. Separately wire the high and low voltage line.
3. Use heat-proof electrical wiring capable of withstanding temperatures up to 167°F.
4. Use outdoor and waterproof connection cable rated more than DC 100V/3A for the connection between indoor and outdoor unit.

Outdoor unit

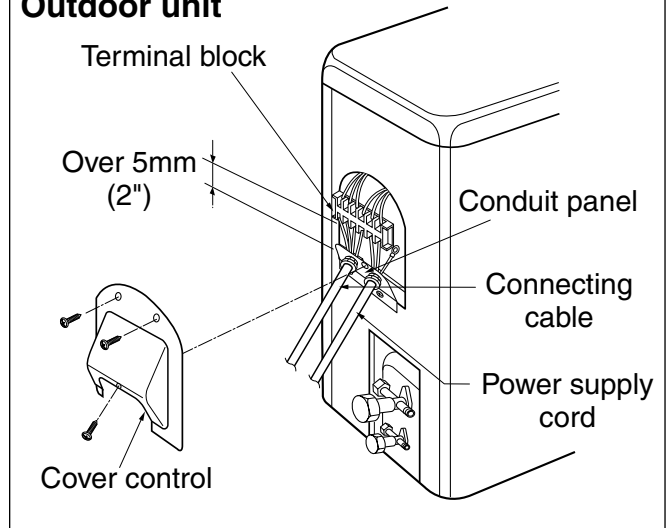

Connection method of the connecting cable(Example)

- (1) Dismount two-caps on the conduit panel.
- (2) Make a hole appropriate for the passage of connection cable through on cap by tool. (for low voltage line)
- (3) Pass the connecting cable through the hole.
- (4) Properly connect the cable on the terminal block.
- (5) Fix the connection cable with clamp cord provided on the unit not to have strain at the terminal when the connection cable is pulled outside up to a 35 pound weight.
- (6) Wind the vinyl tape round the connecting cable for sealing between the surface of the connection cable and cap.
- (7) Mount the taped part of cable on the cap.
- (8) Finally, mount the holed cap with the wound cable on the conduit panel.

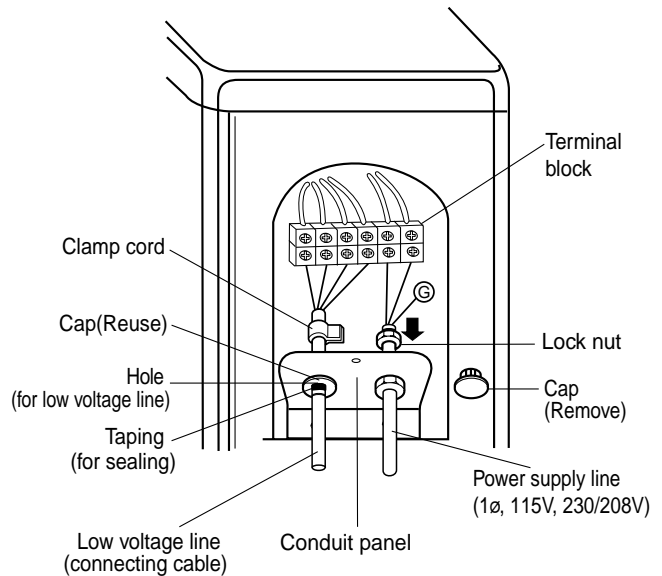

⚠ WARNING

Loose wiring may cause the terminal to overheat or result in unit malfunction. A fire hazard may also exist. Therefore, be sure all wiring is tightly connected.

When connecting each power wire to the corresponding terminal, follow instructions "How to connect wiring to the terminals" and fasten the wire tightly with the fixing screw of the terminal plate.

How to connect wiring to the terminals

■ For solid core wiring (or F-cable)

- (1) Cut the wire end with a wire cutter or wire-cutting pliers, then strip the insulation to expose the solid wire about 25mm(15/16")
- (2) Using a screwdriver, remove the terminal screw(s) on the terminal plate.
- (3) Using pliers, bend the solid wire to form a loop suitable for the terminal screw.
- (4) Shape the loop wire properly, place it on the terminal plate and tighten securely with the terminal screw using a screwdriver.

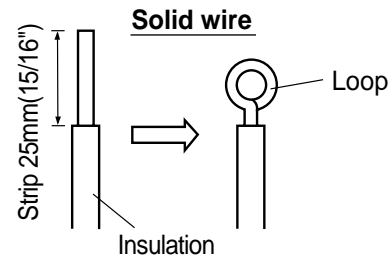

■ For strand wiring

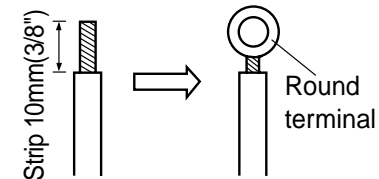

■ For strand wiring

- (1) Cut the wire end with a wire cutter or wire-cutting pliers, then strip the insulation to expose the strand wiring about 10mm(3/8").
- (2) Using a screwdriver, remove the terminal screw(s) on the terminal plate.
- (3) Using a round terminal fastener or pliers, securely clamp each stripped wire end with a round terminal.
- (4) Position the round terminal wire, and replace and tighten the terminal screw using a screwdriver.

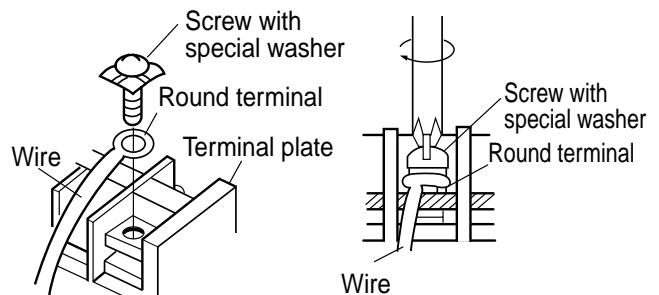

CAUTION

If a power plug is not to be used, provide a circuit breaker between power source and the unit as shown below.

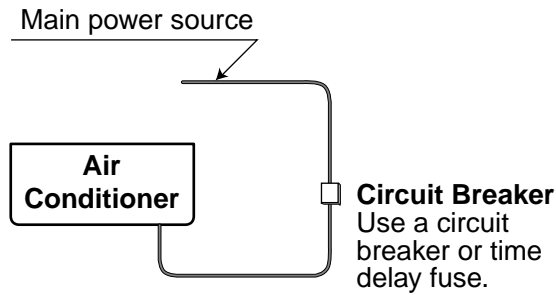

Connect the cable to the indoor unit

1. Connect the wires to the terminals on the control board individually according to the outdoor unit connection.

- Ensure that the color of the wires of outdoor unit and the terminal No. are the same as those of indoor unit respectively. (Refer to Wiring diagram on page11.)

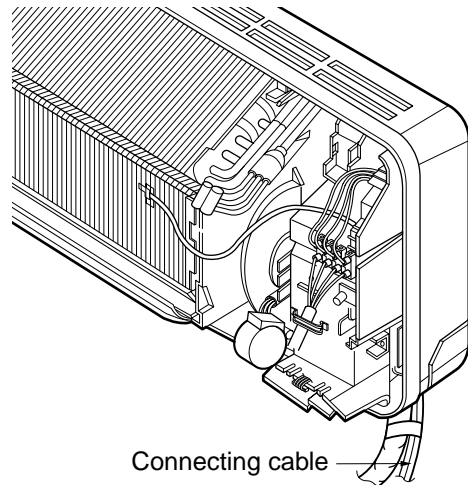

WARNING

- Be sure to refer to the wiring diagram label inside the cover control and carry out the correct field wiring. Wrong wiring can cause the unit to misoperate to result in a fire hazard.
- Check local electrical codes and any specified wiring instructions or limitations.

2. Attach the Grille onto the cabinet.

- Grasp lower the left and right side of the Grille and engage four tabs on the top inside edge of the chassis.
- Press the Grille toward the chassis until it will be back into place.

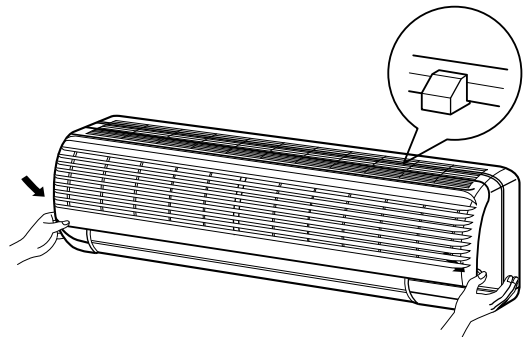

(5) Checking the Drainage and forming the pipings

1) Checking the drainage

1. To remove the front panel from the indoor unit, remove the front panel from the indoor unit cabinet.

- Set the air direction louvers up-and-down to the position(horizontally) by hand.
- Remove the securing screws that retain the front panel. Pull the lower left and right sides of the grille toward you and lift it off. (9K Btu models: 2EA, 12K Btu models: 3EA)

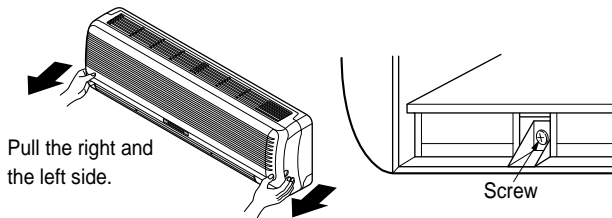

2. To check the drainage.

- Pour a glass of water on the evaporator.
- Ensure the water flows through the drain hose of the indoor unit without any leakage and goes out the drain exit.

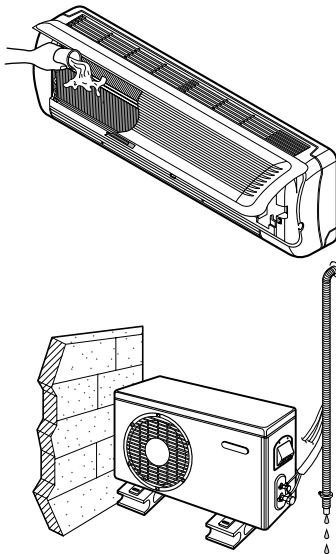

3. Drain piping

- The drain hose should point downward for easy drain flow.

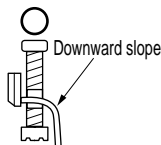

- Do not make drain piping.

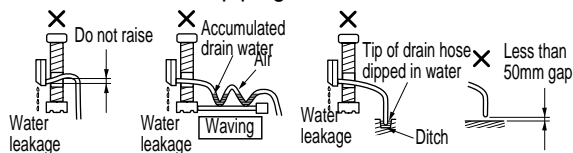

2) Form the piping

1. Form the piping by wrapping the connecting portion of the indoor unit with insulation material and secure it with two kinds of vinyl tapes.

- If you want to connect an additional drain hose, the end of the drain outlet should be routed above the ground. Secure the drain hose appropriately.

2. In cases where the outdoor unit is installed below the indoor unit perform the following.

- Tape the piping, drain hose and connecting cable from down to up.
- Secure the tapped piping along the exterior wall using saddle or equivalent

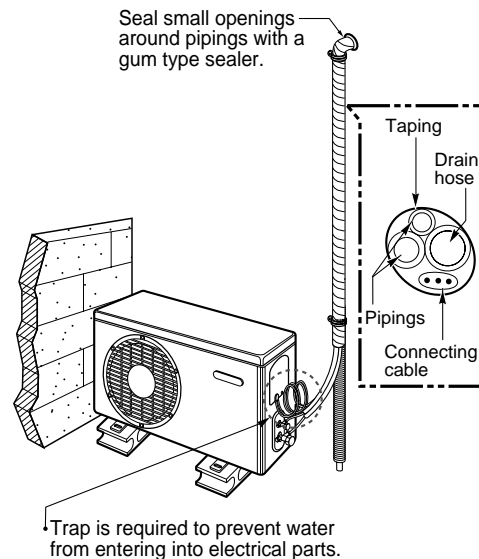

3. In cases where the Outdoor unit is installed above the Indoor unit perform the following.

- Tape the piping and connecting cable from down to up.
- Secure the taped piping along the exterior wall. Form a trap to prevent water entering the room.
- Fix the piping onto the wall by saddle or equivalent.

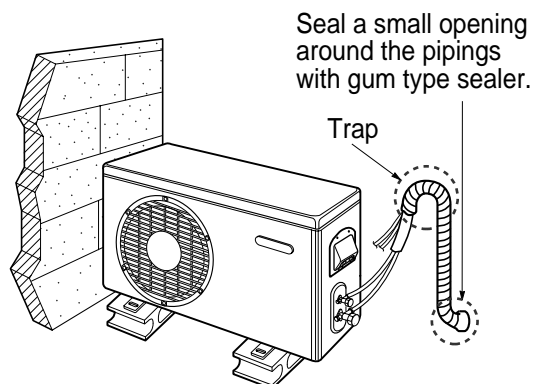

(6) Air Purging

Air and moisture remaining in the refrigerant system have undesirable effects as indicated below.

- Pressure in the system rises.
- Operating current rises.
- Cooling(or heating) efficiency drops.
- Moisture in the refrigerant circuit may freeze and block capillary tubing.
- Water may lead to corrosion of parts in the refrigeration system.

Therefore, the indoor unit and tubing between the indoor and outdoor unit must be leak tested and evacuated to remove any noncondensables and moisture from the system.

Air Purging with a Vacuum Pump

■ Preparation

Check that each tube(both liquid and gas side tubes) between the indoor and outdoor units has been properly connected and all wiring for the test run has been completed. Remove the valve caps from both the gas and the liquid side service valves on the outdoor unit. Note that both liquid and gas side service valves on the outdoor unit are kept closed at this stage.

■ Leak test

1. **Connect the manifold valve(with pressure gauges) and dry nitrogen gas cylinder to this service port with charge hoses.**

CAUTION: Be sure to use a manifold valve for air purging. If it is not available, use a stop valve for this purpose. The "Hi" knob of the manifold valve must always be kept close.

2. **Pressurize the system to no more than 150 P.S.I.G with dry nitrogen gas and close the cylinder valve when the gauge reading reached 150 P.S.I.G. Next, test for leaks with liquid soap.**

CAUTION: To avoid nitrogen entering the refrigerant system in a liquid state, the top of the cylinder must be higher than its bottom when you pressurize the system. Usually, the cylinder is used in a vertical standing position.

3. **Do a leak test of all joints of the tubing(both indoor and outdoor) and both gas and liquid side service valves. Bubbles indicate a leak. Be sure to wipe off the soap with a clean cloth.**
4. **After the system is found to be free of leaks, relieve the nitrogen pressure by loosening the charge hose connector at the nitrogen cylinder. When the system pressure is reduced to normal, disconnect the hose from the cylinder.**

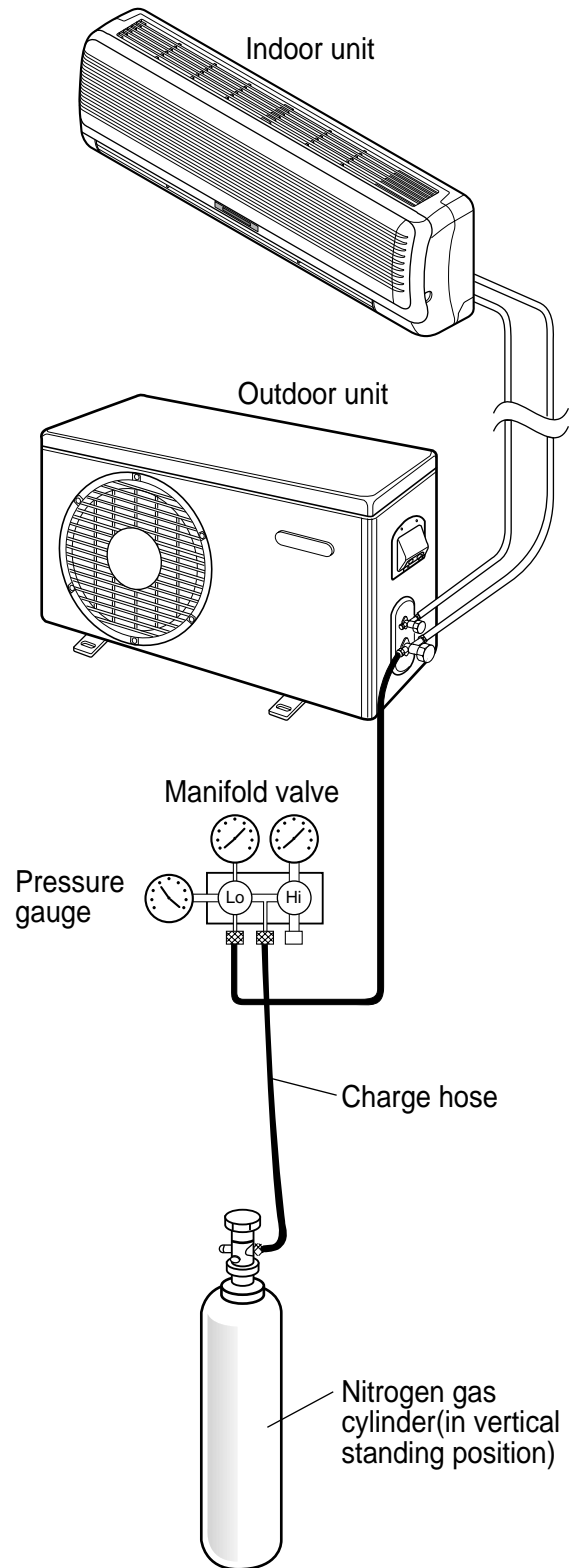

■ Evacuation

1. Connect the charge hose end described in the preceding steps to the vacuum pump to evacuate the tubing and indoor unit.

Confirm the "Lo" knob of the manifold valve is open. Then, run the vacuum pump.

The operation time for evacuation varied with the tubing length and capacity of the pump. The following table shows the amount of time for evacuation. Allow the pump to operate until the system has been evacuated down to 300 microns. Allow the pump to continue running for an additional 15 minutes. Turn off the pump and leave the connections secured to the two service valves. After 5 minutes, if the system fails to hold 500 microns or less, check all connections for tight fit and repeat the evacuation procedure.

2. When the desired vacuum is reached, close the "Lo" knob of the manifold valve and stop the vacuum pump.

■ Finishing the job

1. With a service valve wrench, turn the valve stem of liquid side valve counter-clockwise to fully open the valve.
2. Turn the valve stem of gas side valve counter-clockwise to fully open the valve.
3. Loosen the charge hose connected to the gas side service port slightly to release the pressure, then remove the hose.
4. Replace the flare nut and its bonnet on the gas side service port and fasten the flare nut securely with an adjustable wrench. This process is very important to prevent gas leakage from the system.
5. Replace the valve caps at both gas and liquid side service valves and fasten them securely tight.

This complete air purging with a vacuum pump. The air conditioner is now ready to test run.

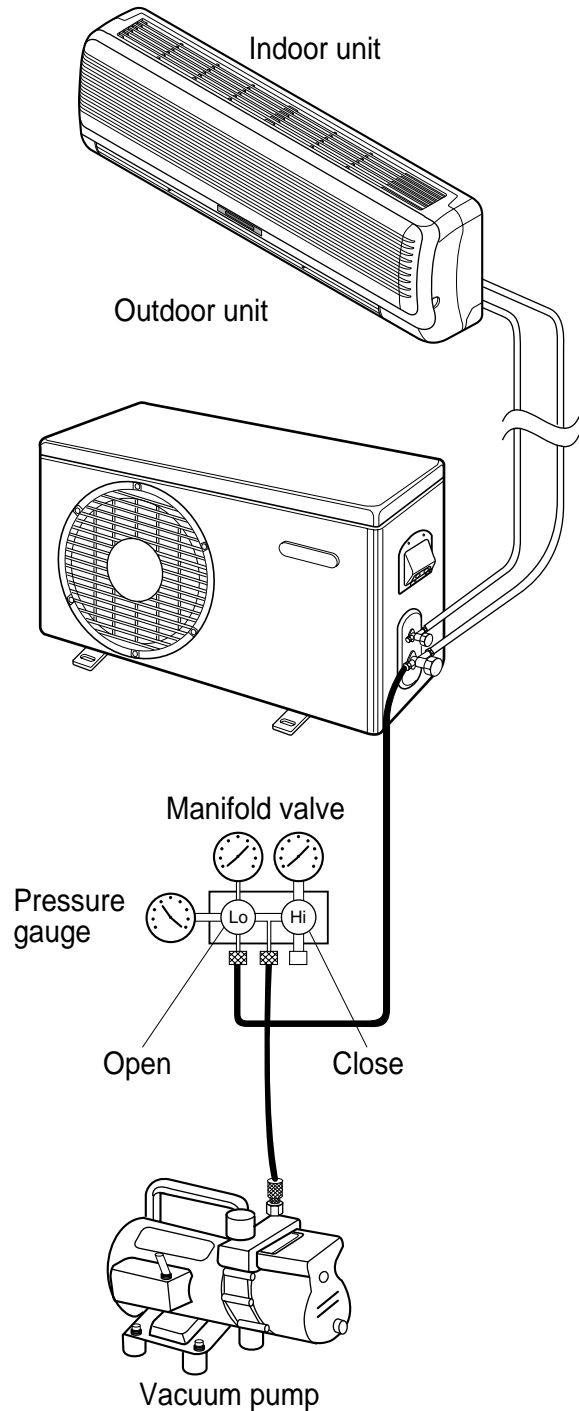

(7) Test running

1. Check that all tubing and wiring have been properly connected.
2. Check that the gas and liquid side service valves are fully open.

1. Prepare remote control

- 1 Remove the battery cover by pulling it according to the arrow direction.
- 2 Insert new batteries making sure that the (+) and (-) of battery are installed correctly.
- 3 Reattach the cover by pushing it back into position.

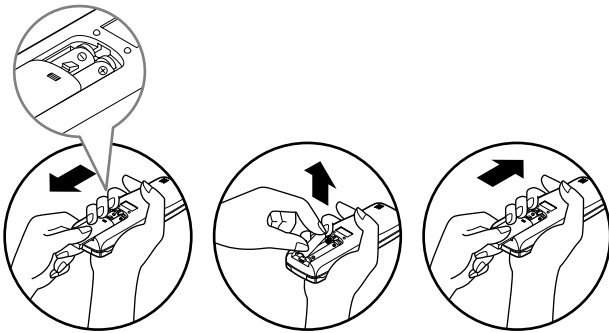

NOTE:

- Use 2 AAA(1.5volt) batteries. Do not use rechargeable batteries.
- Remove the batteries from the remote control if the system is not going to be used for a long time.

2. Settlement of outdoor unit

- Anchor the outdoor unit with a bolt and nut($\phi 10\text{mm}:0.39''$) tightly and horizontally on a concrete or rigid mount.
- When installing on the wall, roof or rooftop, anchor the mounting base securely with a nail or wire assuming the influence of wind and earthquake.
- In the case when the vibration of the unit is conveyed to the hose, secure the unit with an anti-vibration rubber.

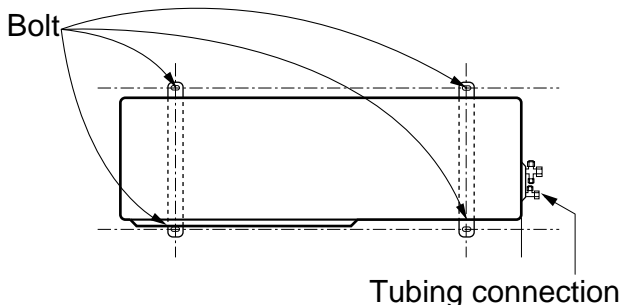

3. Evaluation of the performance

Operate unit for 15~20 minutes, then check the system refrigerant charge:

1. Measure the pressure of the gas side service valve.
2. Measure the temperature of the intake and discharge of air.
3. Ensure the difference between the intake temperature and the discharge is more than $8^{\circ}\text{C}(46^{\circ}\text{F})$ (Cooling) or reversely (Heating).
4. For reference; the gas side pressure of optimum condition is as below. (Cooling)

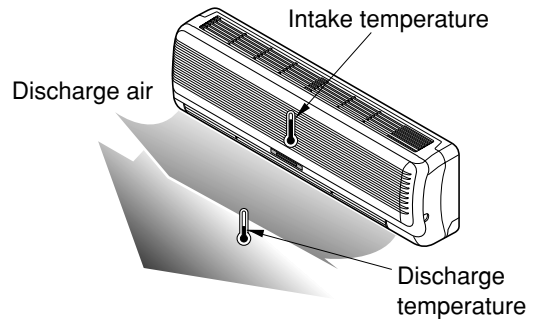

Outside ambient TEMP.	The pressure of the gas side service valve
35°C(95°F)	4.5~5.5kg/cm ² G (63.9~78.1 P.S.I.G.)

NOTE:

- If the actual pressure are higher than shown, the system is most likely over-charged, and charge should be removed. If the actual pressure are lower than shown, the system is most likely undercharged, and charge should be added.
- The air conditioner is now ready for use.

PUMP DOWN

This is performed when the unit is to be relocated or the refrigerant circuit is serviced.

Pump Down means collecting all refrigerant in the outdoor unit without loss in refrigerant gas.

CAUTION:

Be sure to perform Pump Down procedure with the unit cooling mode.

Pump Down Procedure

1. Connect a low-pressure gauge manifold hose to the charge port on the gas side service valve.
2. Open the gas side service valve halfway and purge the air from the manifold hose using the refrigerant gas.
3. Close the liquid side service valve(all the way in).
4. Turn on the unit's operating switch and start the cooling operation.
5. When the low-pressure gauge reading becomes 1 to 0.5kg/cm² G(14.2 to 7.1 P.S.I.G.), fully close the gas side valve stem and then quickly turn off the unit. At that time, Pump Down has been completed and all refrigerant gas will have been collected in the outdoor unit.

Operation

(1) Name and Function-Remote Control (Cooling Models)

Remote Controller

Signal transmitter.

Transmits the signals to the room air conditioner.

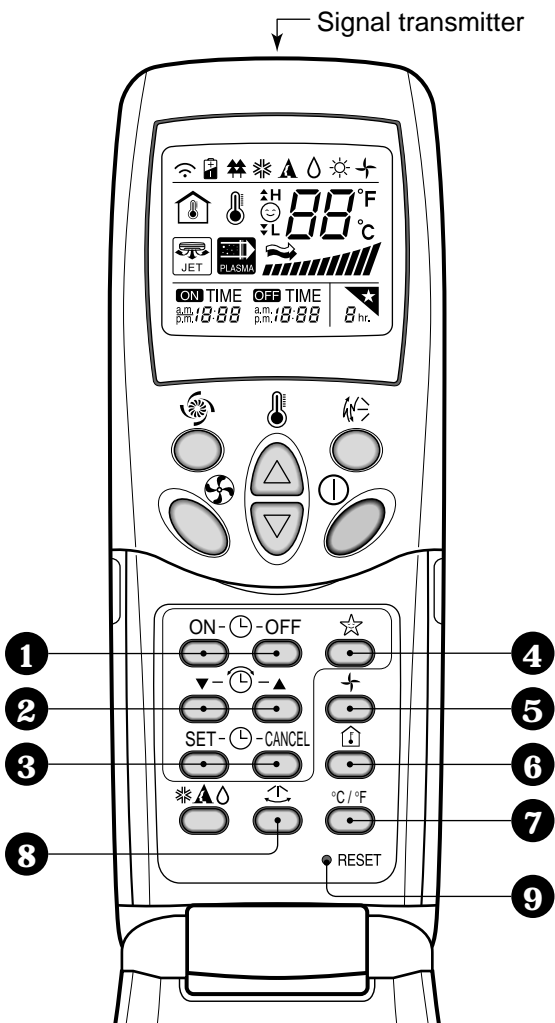

- 1 ON/OFF TIMER BUTTONS**
Used to set the time of starting and stopping operation.
- 2 TIME SETTING BUTTONS**
Used to adjust the time.
- 3 TIMER SET/CANCEL BUTTONS**
Used to set the timer when the desired time is obtained and to cancel the Timer operation.
- 4 SLEEP MODE AUTO BUTTON**
Used to set Sleep Mode Auto operation.
- 5 AIR CIRCULATION BUTTON**
Used to circulate the room air without cooling or heating (turns indoor fan on/off).
- 6 ROOM TEMPERATURE CHECKING BUTTON**
Used to check the room temperature.
- 7 °C / °F SELECTING BUTTON**
Choose temperature unit °C or °F alternatively.
- 8 HORIZONTAL AIRFLOW DIRECTION CONTROL BUTTON (NOT ON ALL MODELS)**
Used to set the desired horizontal airflow direction.
- 9 RESET BUTTON**
Used prior to resetting time or after replacing batteries.

(2) Name and Function-Remote Control (Heat Pump Models)

Remote Controller

Signal transmitter.

Transmits the signals to the room air conditioner.

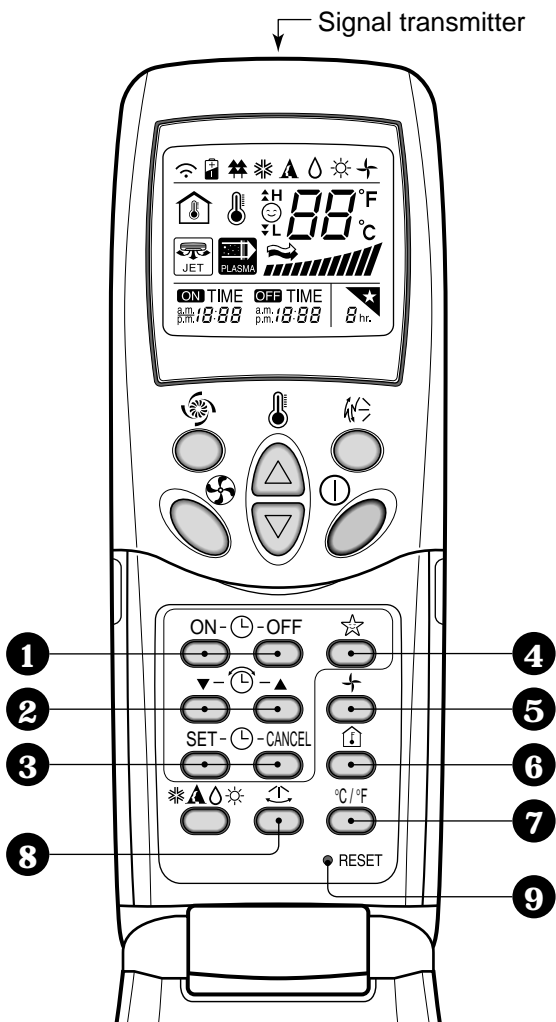

- 1 ON/OFF TIMER BUTTON**
Used to set the time of starting and stopping operation.
- 2 TIME SETTING BUTTONS**
Used to adjust the time.
- 3 TIMER SET/CANCEL BUTTONS**
Used to set the timer when the desired time is obtained and to cancel the Timer operation.
- 4 SLEEP MODE AUTO BUTTON**
Used to set Sleep Mode Auto operation.
- 5 AIR CIRCULATION BUTTON**
Used to circulate the room air without cooling or heating (turns indoor fan on/off).
- 6 ROOM TEMPERATURE CHECKING BUTTON**
Used to check the room temperature.
- 7 °C / °F SELECTING BUTTON**
Choose temperature unit °C or °F alternatively.
- 8 HORIZONTAL AIRFLOW DIRECTION CONTROL BUTTON (NOT ON ALL MODELS)**
Used to set the desired horizontal airflow direction.
- 9 RESET BUTTON**
Used prior to resetting time or after replacing batteries.

Disassembly of the parts (Indoor unit)

(1) 9K, 12K Models(Cooling Only, Cooling & Heating)

Warning :

Disconnect the unit from power supply before making any checks.

Be sure the power switch is set to "OFF".

To remove the Grille from the Chassis.

- Set the up-and-down air discharge louver to open position (horizontally) by finger pressure.
- Remove the securing screws (9K Btu models: 2EA).
- To remove the Grille, pull the lower left and right side of the grille toward you (slightly tilted) and lift it straight upward.

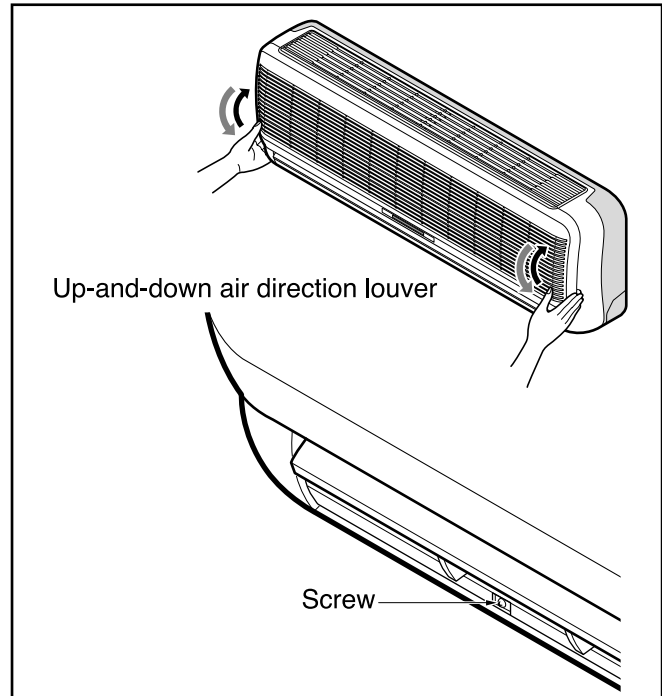

1. To remove the sensor, housing connect, earth conductor & step motor conductor with sensor holder, Motor, Evaporator & P.C.B.

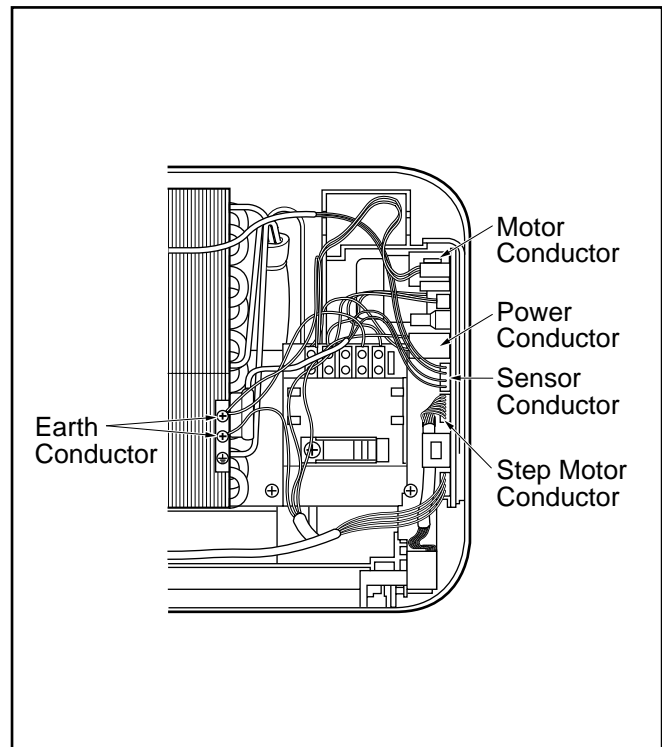

2. To remove the Control Box.

- Remove 2 securing screws.
- Pull the control box out from the chassis carefully.

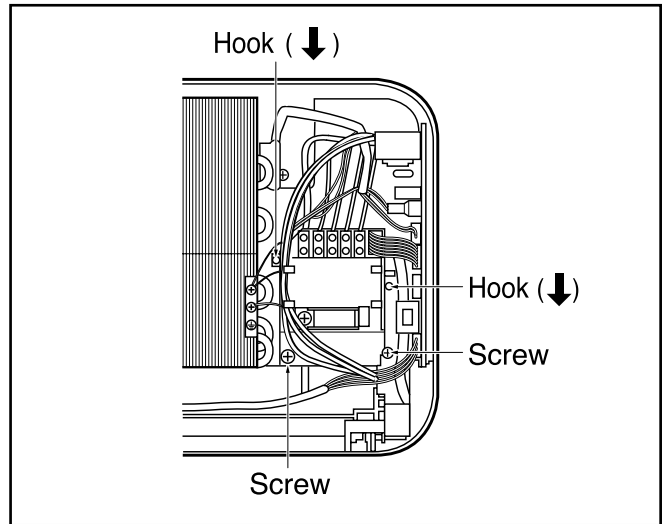

3. To remove the Discharge Grille.

- Unhook the discharge grille and pull the discharge grille out from the chassis carefully.

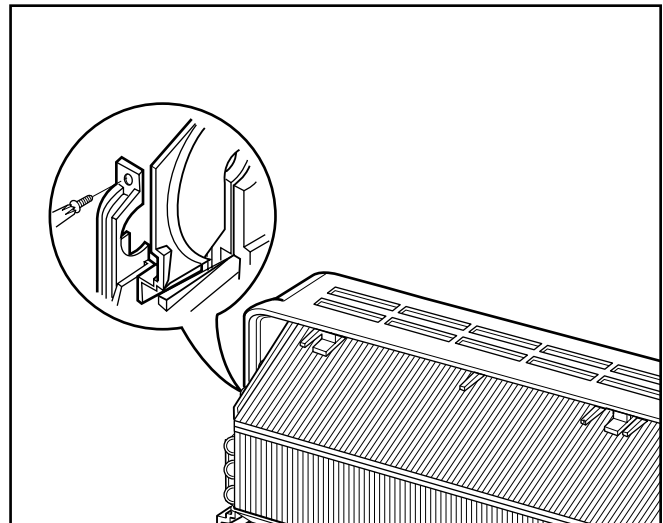

4. To remove the Evaporator.

- Remove 3 screws securing the evaporator(at the left 2EA in the Eva Holder, at the right 1EA).

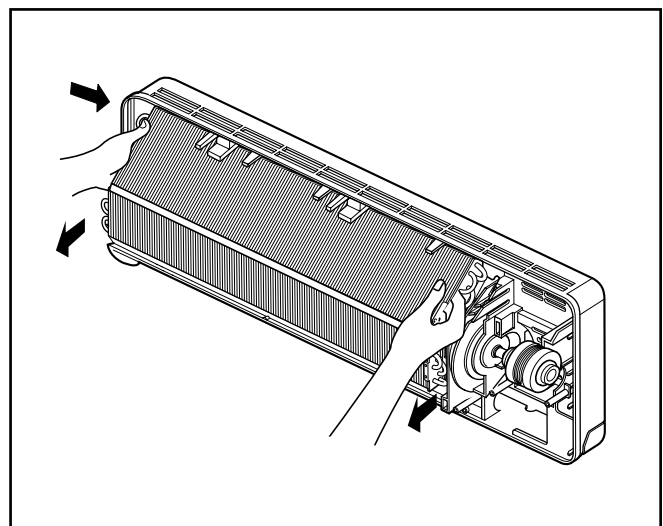

- Unhook the tab on the right inside of the chassis at the same time, slightly pull the evaporator toward you until the tab is clear of the slot.

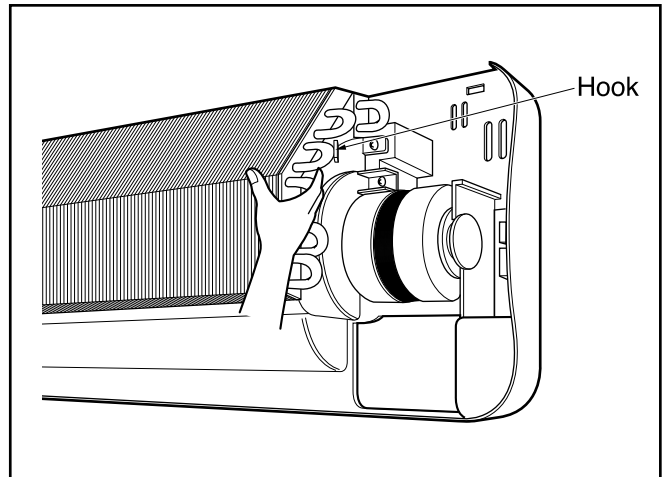

5. To remove the Cross-Flow Fan

- Loosen the screw securing the cross-flow fan to the fan motor (do not remove).
- Lift up the right side of the cross-flow fan and the fan motor, separate the fan motor from the cross-flow fan.

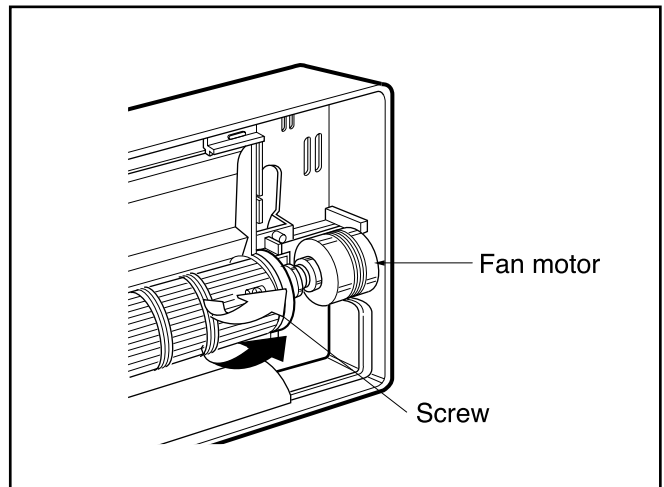

- Remove the left end of the cross-flow fan from the self-aligning bearing.

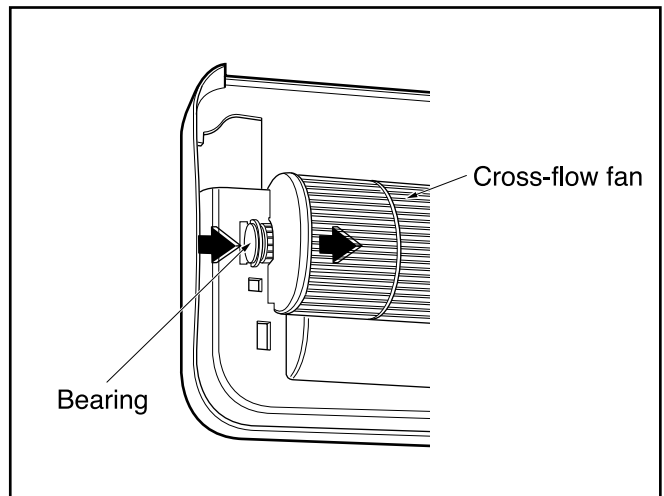

(2) 18K, 24K, Models Cooling Only, Cooling & Heating)

Warning :

Disconnect the unit from power supply before making any checks.

Be sure the power switch is set to "OFF".

To remove the Grille from the Chassis.

- Set the up-and-down air discharge louver to open position (horizontally) by finger pressure.
- Remove the securing screws
- To remove the Grille, pull the lower left and right side of the grille toward you (slightly tilted) and lift it straight upward.

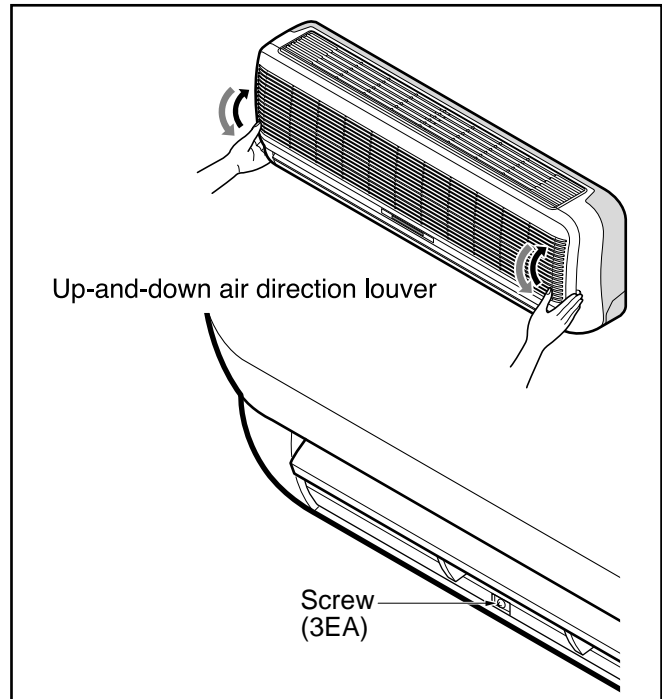

1. To remove the sensor, housing connect, earth conductor & step motor conductor with sensor holder, Motor, Evaporator & P.C.B.

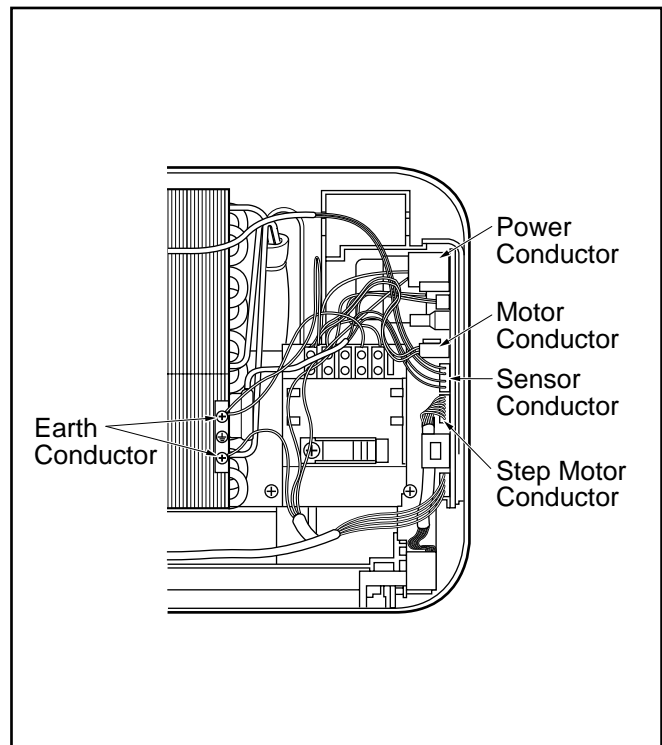

2. To remove the Control Box.

- Remove 2 securing screws.
- Pull the control box out from the chassis carefully.

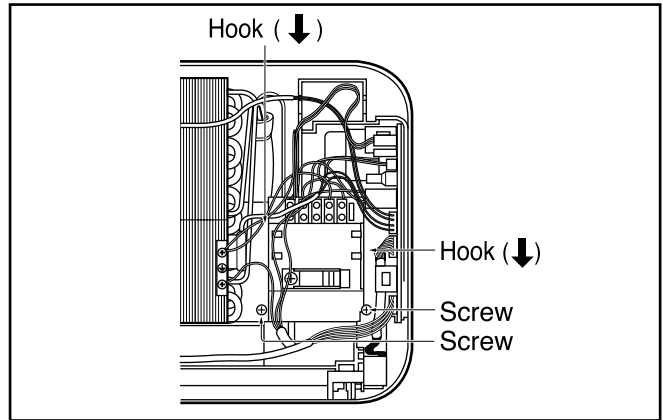

3. To remove the Discharge Grille.

- Remove the securing screw.
- Pressing the right side of the discharge grille downward slightly, unhook the discharge grille.
- Pull the discharge grille out from the chassis carefully.

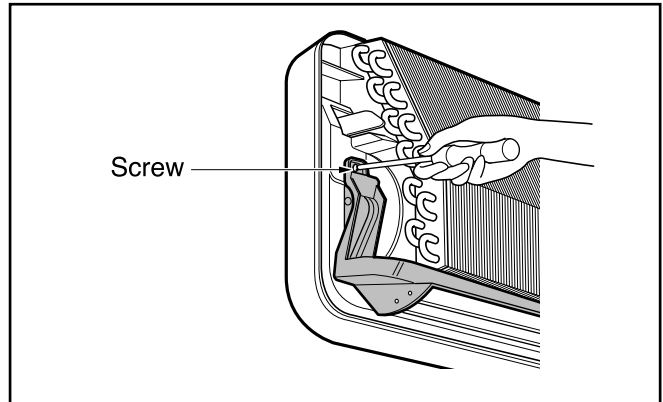

4. To remove the Evaporator.

- Remove 3 screws securing the evaporator(at the left 1EA, at the right 2EA).

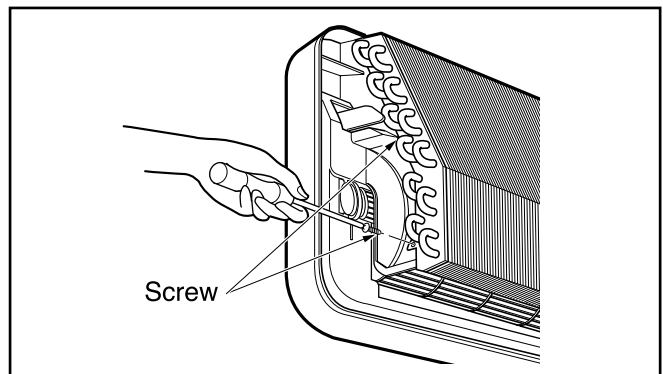
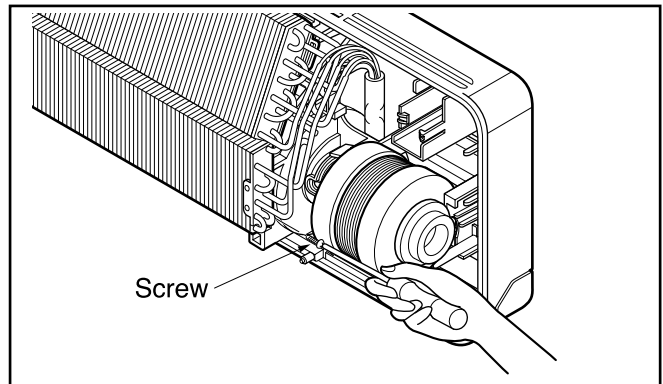

- Unhook the tab on the right inside of the chassis at the same time, slightly pull the evaporator toward you until the tab is clear of the slot.

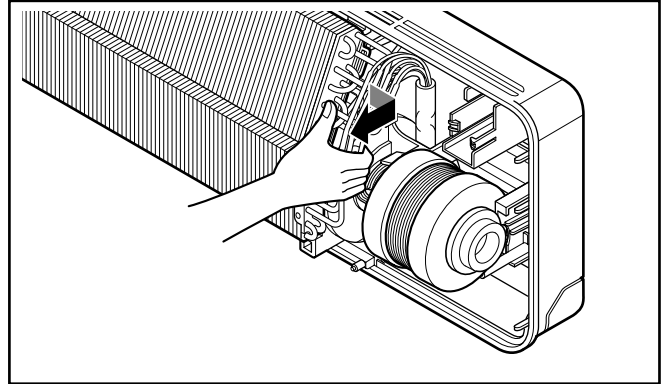

5. To remove the Cross-Flow Fan

- Loosen the screw securing the cross-flow fan to the fan motor (do not remove).
- Lift up the right side of the cross-flow fan and the fan motor, separate the fan motor from the cross-flow fan.

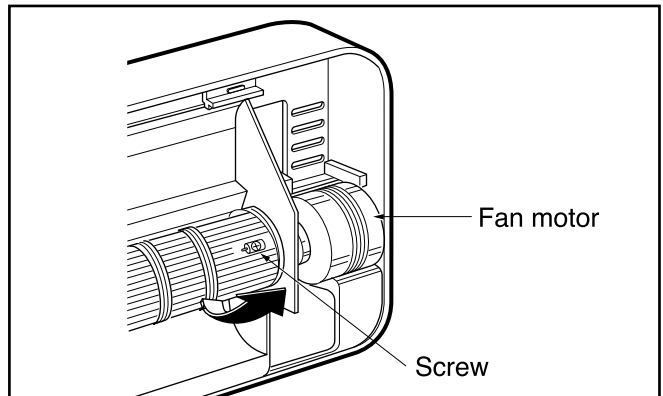

- Remove the left end of the cross-flow fan from the self-aligning bearing.

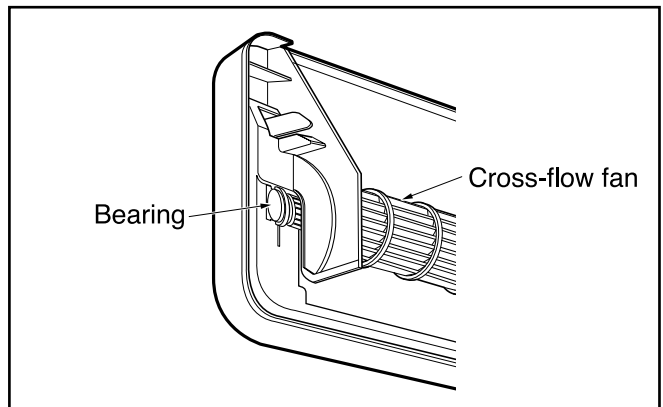

Cycle Troubleshooting Guide

1. Trouble analysis

1. Check temperature difference between intake and discharge air and operating current.

Temp. Difference	Temp. difference :approx. 0°F Current :less than 80% of rated current	All amount of refrigerant leaked out. Check refrigeration cycle.
	Temp. difference :approx. 8°C(14°F) Current :less than 80% of rated current	Refrigerant leakage Clog of refrigeration cycle Defective compressor
Operating Current	Temp. difference :less than 8°C(14°F) Current :less than 80% of rated current	Excessive amount of refrigerant
	Temp. difference :over 8°C(14°F)	Normal

Notice:

Temperature difference between intake and discharge air depends on room air humidity. When the room air humidity is relatively higher, temperature difference is smaller. When the room air humidity is relatively lower temperature difference is larger.

2. Check temperature and pressure of refrigeration cycle.

Suction pressure (Compared with the normal value)	Temperature (Compared with the normal value)	Cause of Trouble	Description
Higher	High	Defective compressor Defective 4-way reversing valve	Current is low.
	Normal	Excessive amount of refrigerant	High pressure does not quickly rise at the beginning of operation.
Lower	Higher	Insufficient amount of refrigerant(Leakage) Clogging	Current is low. Current is low.

Notice:

1. The suction pressure is usually 4.5~5.0 kg/cm²G at normal condition.
2. The temperature can be measured by attaching the thermometer to the low pressure tubing and wrap it with putty.

2. Product does not operate at all.

(* Refer to Electronic Control Device drawing and Schematic diagram.)

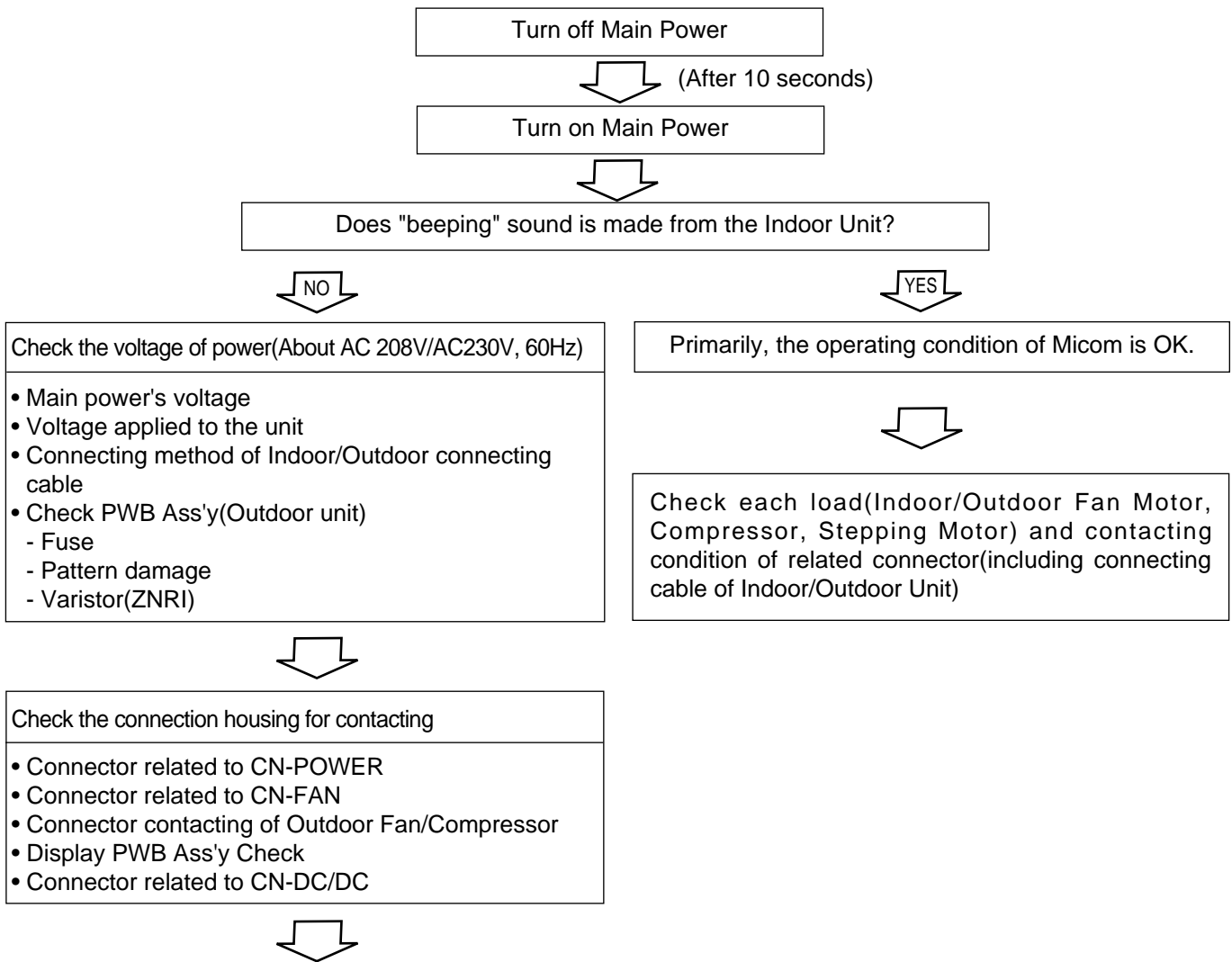

PCB Board Operation Check		
Items	Content	Remedy
<ul style="list-style-type: none"> Power Transformer (Outdoor unit) <ul style="list-style-type: none"> - Input Voltage - Output Voltage 	<ul style="list-style-type: none"> - About AC208V/230V±10% - Check the power voltage - About AC17±3V 	<ul style="list-style-type: none"> • Replace Trans
<ul style="list-style-type: none"> IC2(7812) Output (Indoor/Outdoor unit) 	<ul style="list-style-type: none"> • DC +12V 	<ul style="list-style-type: none"> • Replace IC2
<ul style="list-style-type: none"> IC3(7805) Output (Indoor/Outdoor unit) 	<ul style="list-style-type: none"> • DC +5V 	<ul style="list-style-type: none"> • Replace IC3
<ul style="list-style-type: none"> IC4(KIA7036, Reset IC) OSC01B(4MHz) (Indoor/Outdoor unit) 	<ul style="list-style-type: none"> • Voltage of Outdoor unit Micom No. 8, Voltage of Indoor unit Micom No. 43 and soldering condition 	<ul style="list-style-type: none"> • Replace faulty parts

3. The product is not operate with the remote controller.

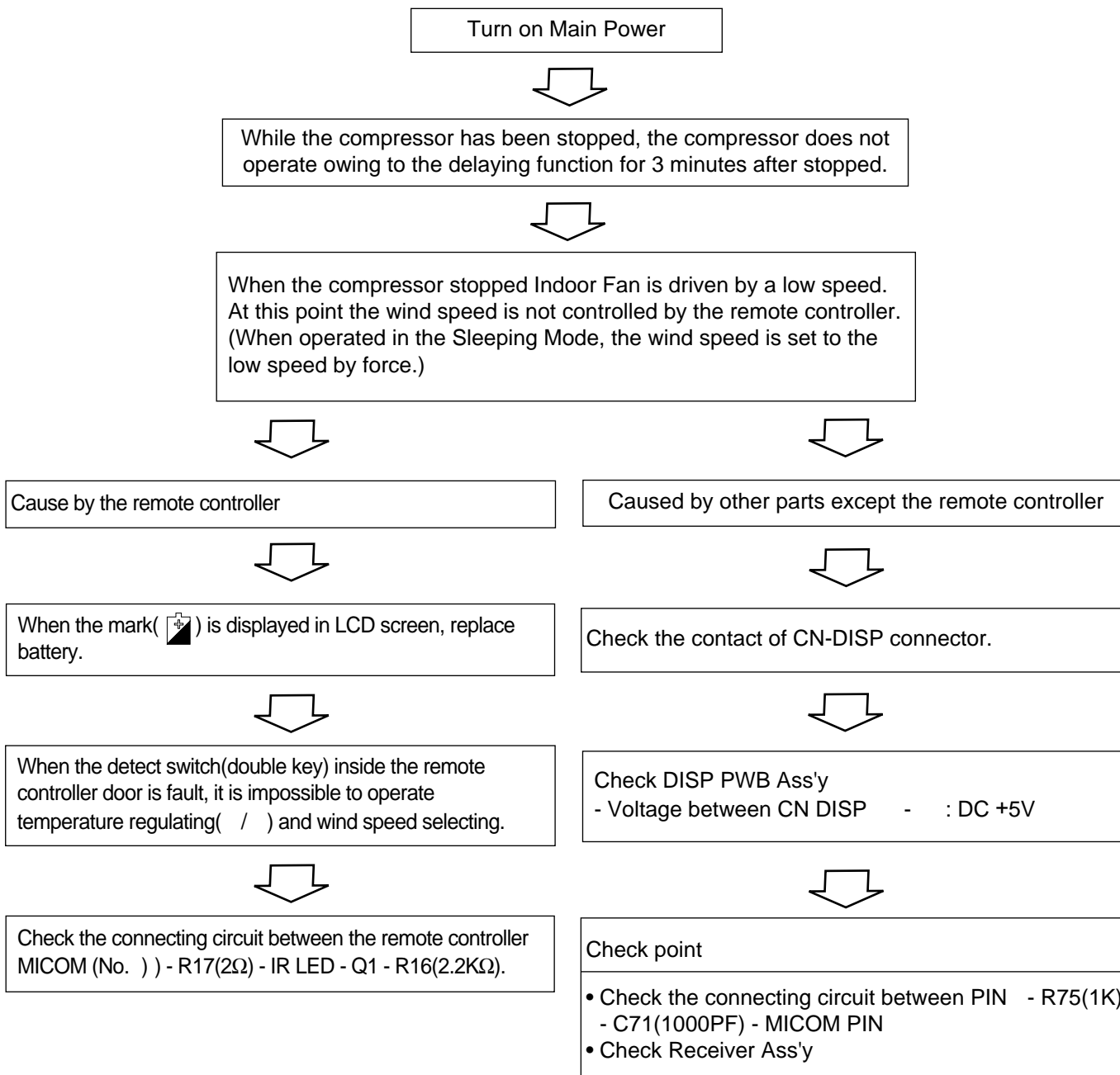

4. Compressor/Outdoor Fan are unable to drive.

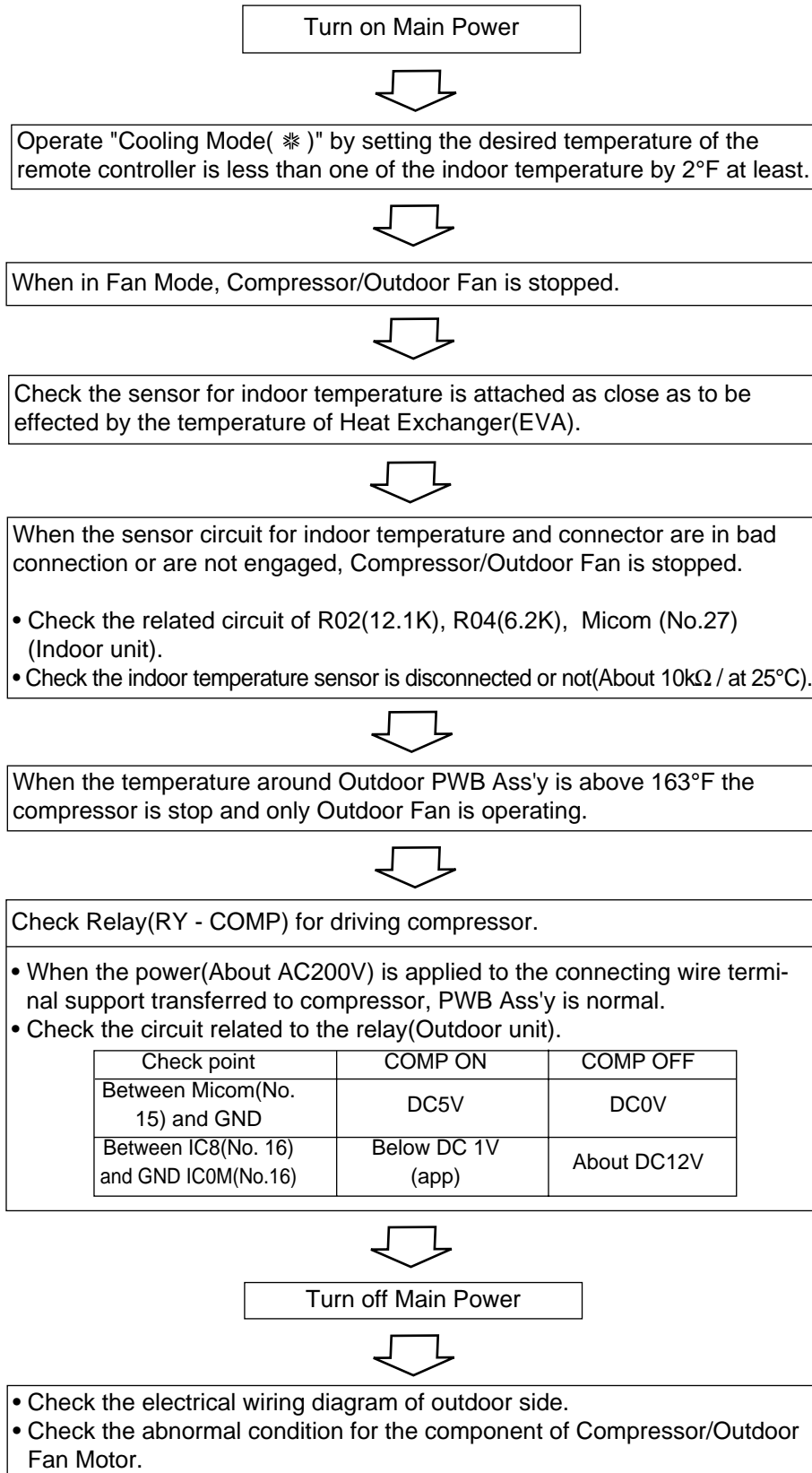

5. When Indoor Fan does not operate.

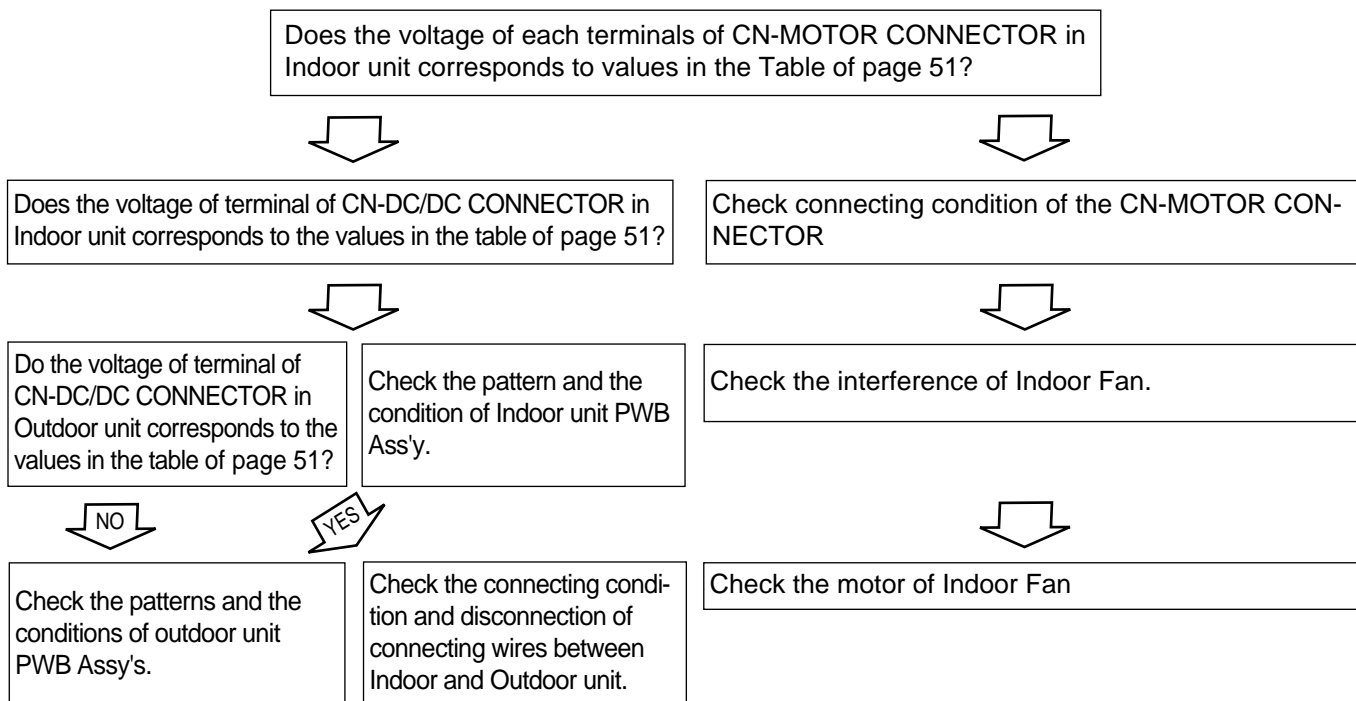

Indoor Fan may be stopped in the Soft Dry Mode(change to the Cooling Operation Mode).

Indoor Fan is to be stopped when Indoor pipe(coil) temperature is lower than 79°F.

(At that times, Defrost indicator is turned on)

6. When Vertical Louver does not operate.

- Confirm that the Vertical Louver is normally geared with the shaft of Stepping Motor.
- If the regular torque is detected when rotating the Vertical Louver with hands Normal



- Check the connecting condition of CN-UP/DOWN Connector
- Check the soldering condition(on PWB) of CN-UP/DOWN Connector



Check the operating circuit of the Vertical Louver

- Confirm that there is DC +12V between pin (RED) of CN-UP/DOWN and GND.
- Confirm that there is a soldering short at following terminals.
 - Between ⑥①, ⑥② and ⑥③ of MICOM
 - Between ③, ④, ⑤ and ⑥ of IC01M
 - Between ①①, ①②, ①③ and ①④ of IC01M
 - Between ①, ②, ③, ④ and ⑤ of CN-UP/DOWN



If there are no problems after above checks

- Confirm the assembly conditions that are catching and interfering parts in the rotation radial of the Vertical Louver

7. When a communication error occurs.

- The operation indicator of Indoor unit blinks five times.
- The red indicator of Outdoor unit blinks five times.



Check the connecting wires between Indoor and Outdoor unit for the connecting error and the contacting condition.



Check the installation condition of outdoor unit.



Check for the communication error and the operating condition of product after also operating with the remote controller, then taking above 2 minutes.



Apply the power again after about 10 seconds by the power of Outdoor unit is off.



Check for the communication error and the operating condition of product after also operating with the remote controller, then taking above 2 minutes.



Check the PWB assembly of Indoor and Outdoor unit.

Caution: If the connecting wires of Indoor and Outdoor unit are not connected within 2 minutes after the power of Outdoor unit is applied, a communication error will occur. Therefore, the power should be applied after connecting them.

8. The phenomena in case of connecting error

INDOOR UNIT

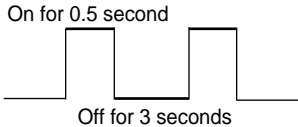
Connector Type	Condition	Phenomena
CN-DC/DC  Blue Black Brown Red	Open and connecting error	<ul style="list-style-type: none"> The same as the phenomenon of Outdoor Unit.
CN-MOTOR	Open	<ul style="list-style-type: none"> The indoor fan does not operate. The operation indicator of Indoor unit blinks 8 times.
CN-UP/DOWN	Open	<ul style="list-style-type: none"> The up/down vane does not operate.
	Short between terminals	<ul style="list-style-type: none"> The up/down vane does not smoothly operate.
CN-DISP	Open	<ul style="list-style-type: none"> It does not operate with a remote controller.
CN-TH	Open	<ul style="list-style-type: none"> The operation indicator blinks once.  <ul style="list-style-type: none"> The compressor and the outdoor fan stop. The indoor fan speed is low.
	Short between terminals (and) of ROOM-TH.	<ul style="list-style-type: none"> The operation indicator blinks once (on for 0.5 second, off for 3 seconds). The compressor operates continuously regardless of the setting temperature and the variation of room temperature.
	Short between terminals (and) of PIPE-TH.	<ul style="list-style-type: none"> The operation indicator blinks once (on for 0.5 second, off for 3 seconds) Continuous operation

OUTDOOR UNIT

Connector Type	Condition	Phenomena
CN-POWER	OPEN	<ul style="list-style-type: none"> All functions stop. The operation with the remote controller, forced and test one do not operate.
	Connecting reversely	<ul style="list-style-type: none"> PWB pattern is damaged when applying the power.
RY-COMP terminal	OPEN	<ul style="list-style-type: none"> All functions stop or the compressor does not operate. The operation with the remote controller, forced and test one do not operate.
	Connecting reversely	<ul style="list-style-type: none"> All functions stop. The operation with the remote controller, forced and test one do not operate.
CN-TRANS	OPEN	<ul style="list-style-type: none"> All functions stop. The operation with the remote controller, forced and test one do not operate.
CN-FAN	OPEN	<ul style="list-style-type: none"> The Indoor Fan does not operate.
The connecting wire of CN-DC/DC, and Indoor and Outdoor Unit  Blue Black Brown Red	OPEN	<ul style="list-style-type: none"> All functions stop. The operation with the remote controller, forced and test one do not operate.
	Connecting error ()	<ul style="list-style-type: none"> The only signal of remote controller operation/stop is inputted, but the product does not operate. The RED indicator of outdoor unit blinks 5 times after 2 minutes with applying the power.
	Connecting error ()	<ul style="list-style-type: none"> The beep sound, such as "beep, beep, beep, beep, beep", occurs periodically in Indoor unit. The signal input of a remote controller and operation of product is impossible. The RED indicator blinks 5 times after 2 minutes with applying the power.
	Connecting error ()	<ul style="list-style-type: none"> The signal of remote controller is inputted, but the product does not operate. The RED indicator of outdoor unit and the operation indicator of indoor one blinks 5 times after 2 minutes with applying the power.
	Connecting error ()	<ul style="list-style-type: none"> No power for Indoor unit. The signal input of the remote controller and operation of product is impossible. The thermal protector of the Power Trans operates when let it alone for long time.
	Connecting error ()	<ul style="list-style-type: none"> The signal of the remote controller is inputted. The fuse and Q61 in the Outdoor unit are damaged when the indoor fan is operated.
	Connecting error ()	<ul style="list-style-type: none"> No power for Indoor unit. The signal input of the remote controller and operation of product is impossible. The RED indicator of the Outdoor unit blinks 5 times after 2 minutes with applying the power.

9. Voltage of Connectors according to Indoor Fan Speed

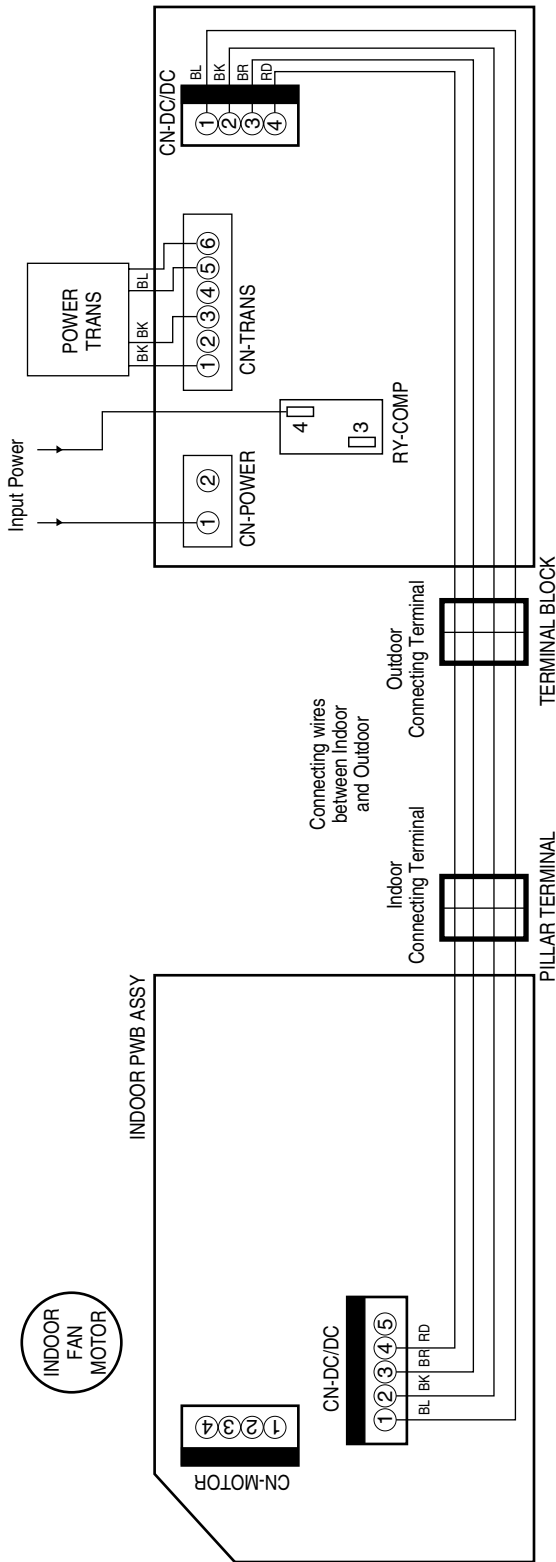

MODELS	No. of pins	9K						12K						18K						24K							
		DC Voltage(±10%)						DC Voltage(±10%)						DC Voltage(±10%)						DC Voltage(±10%)							
CONNELTORS	+	-	S-Hi	Hi	Med	Low	Off	S-Hi	Hi	Med	Low	Off	S-Hi	Hi	Med	Low	Off	S-Hi	Hi	Med	Low	Off	S-Hi	Hi	Med	Low	Off
INDOOR CN-MOTOR	1	2	28.6	25.6	22.2	20.0	0.0	35.7	30.7	25.1	21.2	0.0	32.0	27.8	24.1	21.2	0.0	35.7	33.3	29.4	24.2	0.0	35.7	33.3	29.4	24.2	0.0
	3	2	5.0	5.0	5.0	5.0	5.0	5.0	5.0	5.0	5.0	5.0	5.0	5.0	5.0	5.0	5.0	5.0	5.0	5.0	5.0	5.0	5.0	5.0	5.0	5.0	5.0
	4	2	0~5	0~5	0~5	0~5	5.0	0~5	0~5	0~5	0~5	5.0	0~5	0~5	0~5	0~5	0~5	5.0	0~5	0~5	0~5	0~5	0~5	0~5	0~5	0~5	5.0
	4	3	0~12	0~12	0~12	0~12	0~12	0~12	0~12	0~12	0~12	0~12	0~12	0~12	0~12	0~12	0~12	0~12	0~12	0~12	0~12	0~12	0~12	0~12	0~12	0~12	0~12
INDOOR PILLAR TERMINAL	2	3	17.0	17.0	17.0	17.0	17.0	17.0	17.0	17.0	17.0	17.0	17.0	17.0	17.0	17.0	17.0	17.0	17.0	17.0	17.0	17.0	17.0	17.0	17.0	17.0	17.0
	1	3	28.6	25.6	22.2	20.0	0.0	35.7	30.7	25.1	21.2	0.0	32.0	27.8	24.1	21.2	0.0	35.7	33.3	29.4	24.2	0.0	35.7	33.3	29.4	24.2	0.0
	4	3	0~12	0~12	0~12	0~12	0~12	0~12	0~12	0~12	0~12	0~12	0~12	0~12	0~12	0~12	0~12	0~12	0~12	0~12	0~12	0~12	0~12	0~12	0~12	0~12	0~12
OUTDOOR TERMINAL BLOCK	2	3	17.0	17.0	17.0	17.0	17.0	17.0	17.0	17.0	17.0	17.0	17.0	17.0	17.0	17.0	17.0	17.0	17.0	17.0	17.0	17.0	17.0	17.0	17.0	17.0	17.0
	1	3	29.0	25.9	22.4	20.2	0.0	36.0	30.9	25.3	21.3	0.0	32.3	28.1	24.4	21.3	0.0	36.0	33.7	29.6	24.4	0.0	36.0	33.7	29.6	24.4	0.0

Electronic Control Device

(1) MAIN PWB ASSY(Indoor Unit)

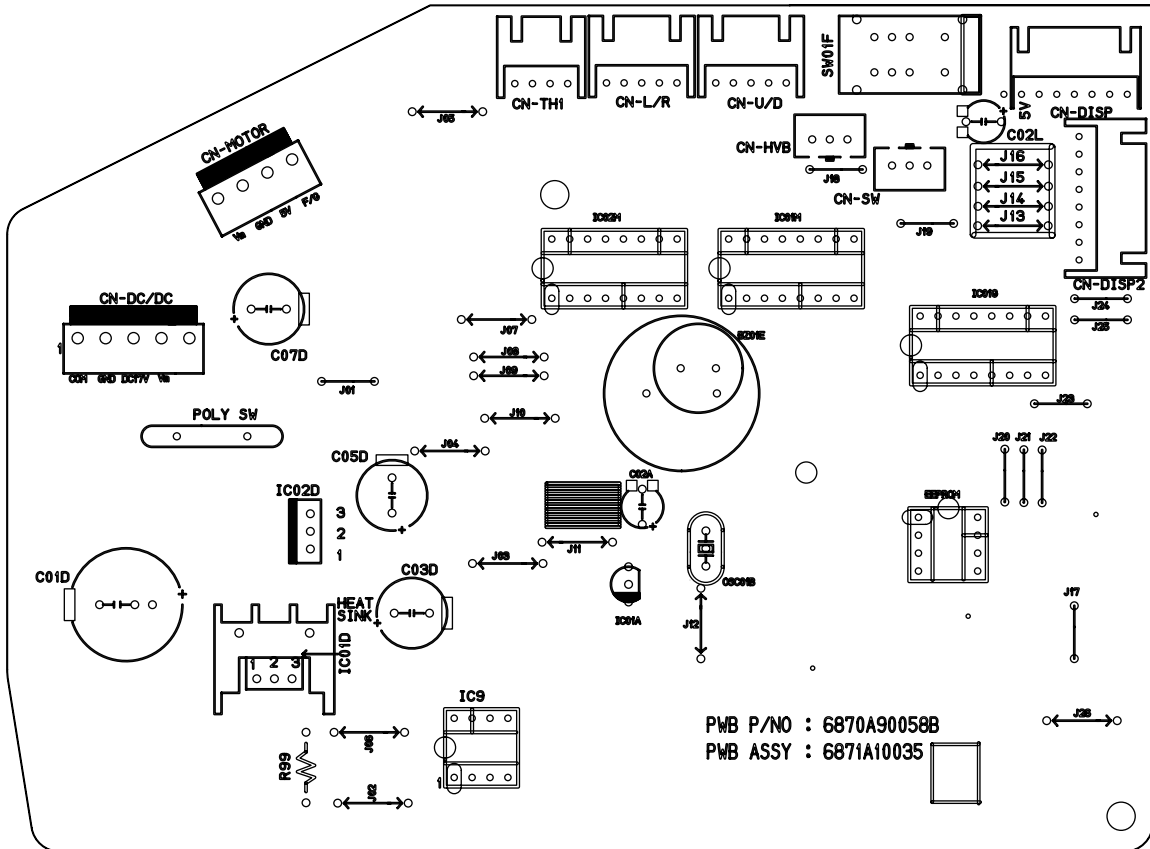

• PWB ASSY SVC PART LIST

NO	MODEL	P/No.	OPTIONAL FUNCTION					
			OR1H	OR2H	OR3H	OR4H	OR5H	OR6H
1	24K Heating Model	6871A10035A	OPEN	56K	3K	OPEN	OPEN	OPEN
2	24K Cooling Model	6871A10035B	12K	56K	3K	OPEN	OPEN	OPEN
3	18K Heating Model	6871A10035C	OPEN	56K	6.8K	OEPN	OPEN	OPEN
4	18K Cooling Model	6871A10035D	12K	56K	6.8K	OPEN	OPEN	OPEN
5	12K Heaing Model	6871A10035E	OPEN	56K	2K	OPEN	OPEN	OPEN
6	12K Cooling Model	6871A10035F	12K	56K	2K	OPEN	OPEN	OPEN
7	9K Cooling Model	6871A10035H	12K	56K	15K	OPEN	OPEN	OPEN

OJ1H, OJ2H : OPEN

OJ3H, OJ4H : Short

(2) MAIN PWB ASSY(Outdoor Unit)

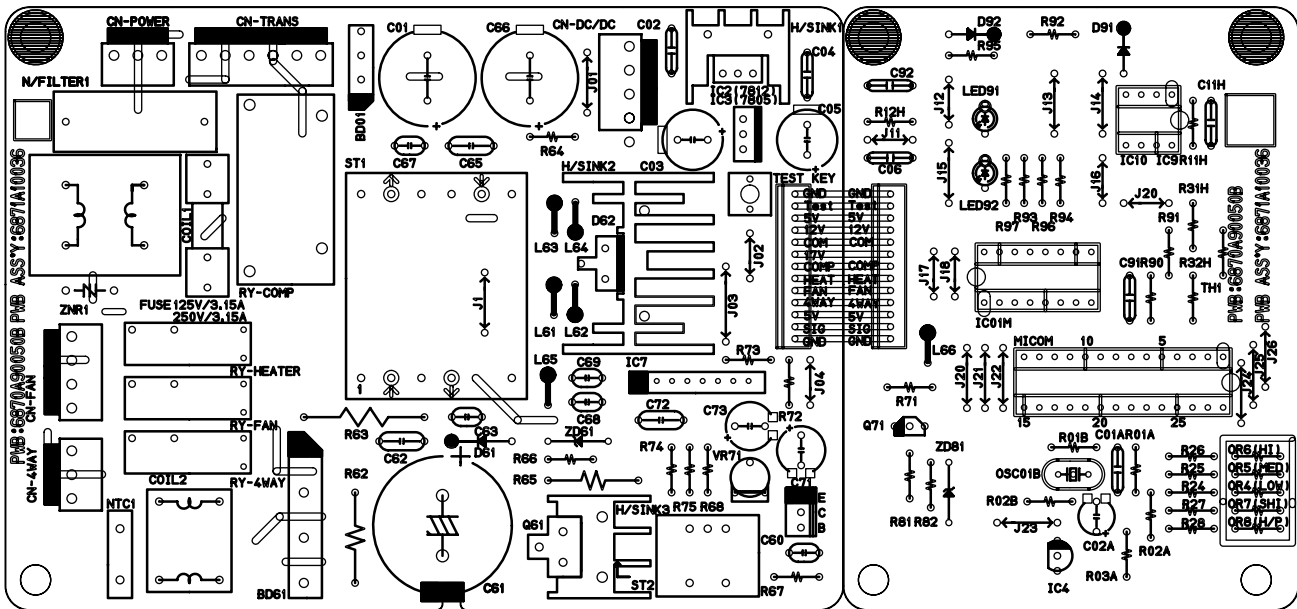

• PWB ASSY SVC PART LIST

NO	MODEL	P/No.	OPTIONAL FUNCTION												
			OR4H	OR5H	OR6H	OR7H	OR 8H	FUSE	RY-HEATER	RY-4WAY	RY-FAN	CN-4WAY	CN-FAN	CN-TH	
1	12K Heating Model	6871A10036E	6.8K	5.1K	1K	OPEN	39K	125V 3.15A	O	O	O	O	O	O	
2	12K Cooling Model	6871A10036F	6.8K	5.1K	1K	OPEN	39K		X	X	X	X	X	X	
3	9K Cooling Model	6871A10036H	6.8K	10K	6.8K	3K	OPEN		X	X	X	X	X	X	
4	18K Heating Model	6871A10036C	6.8K	10K	5.1K	6.8K	12K	250V 3.15A	O	O	O	O	O	O	
5	18K Cooling Model	6871A10036D	6.8K	10K	5.1K	6.8K	12K		X	X	X	X	X	X	
6	24K Heating Model	6871A10036A	3K	2K	6.8K	OPEN	3K		O	O	O	O	O	O	
7	24K Cooling Model	6871A10036G	3K	2K	6.8K	OPEN	3K		X	X	X	X	X	X	

(3) DISPLAY PWB ASSY

<9K, 12K, 18K, 24K>

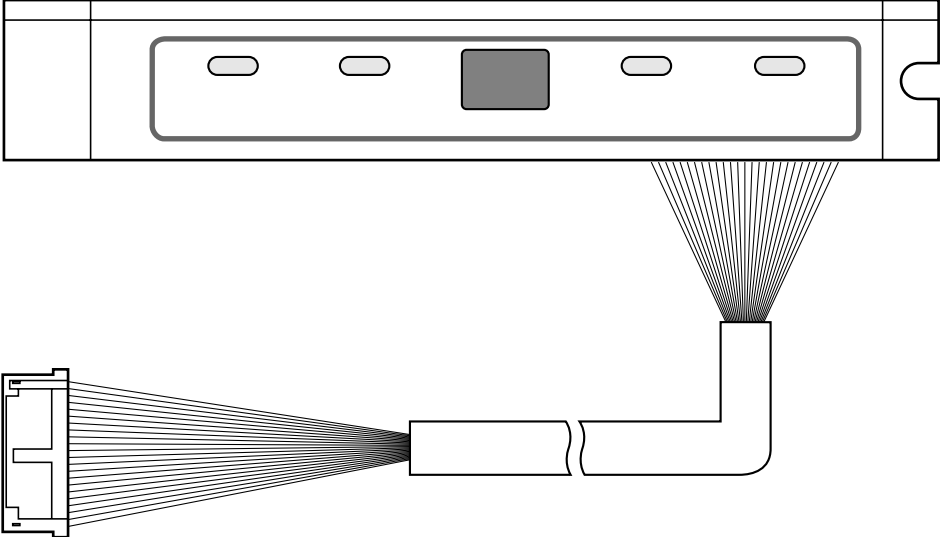

(P/No: 6871A30009C)

Schematic Diagram

1. Indoor Unit

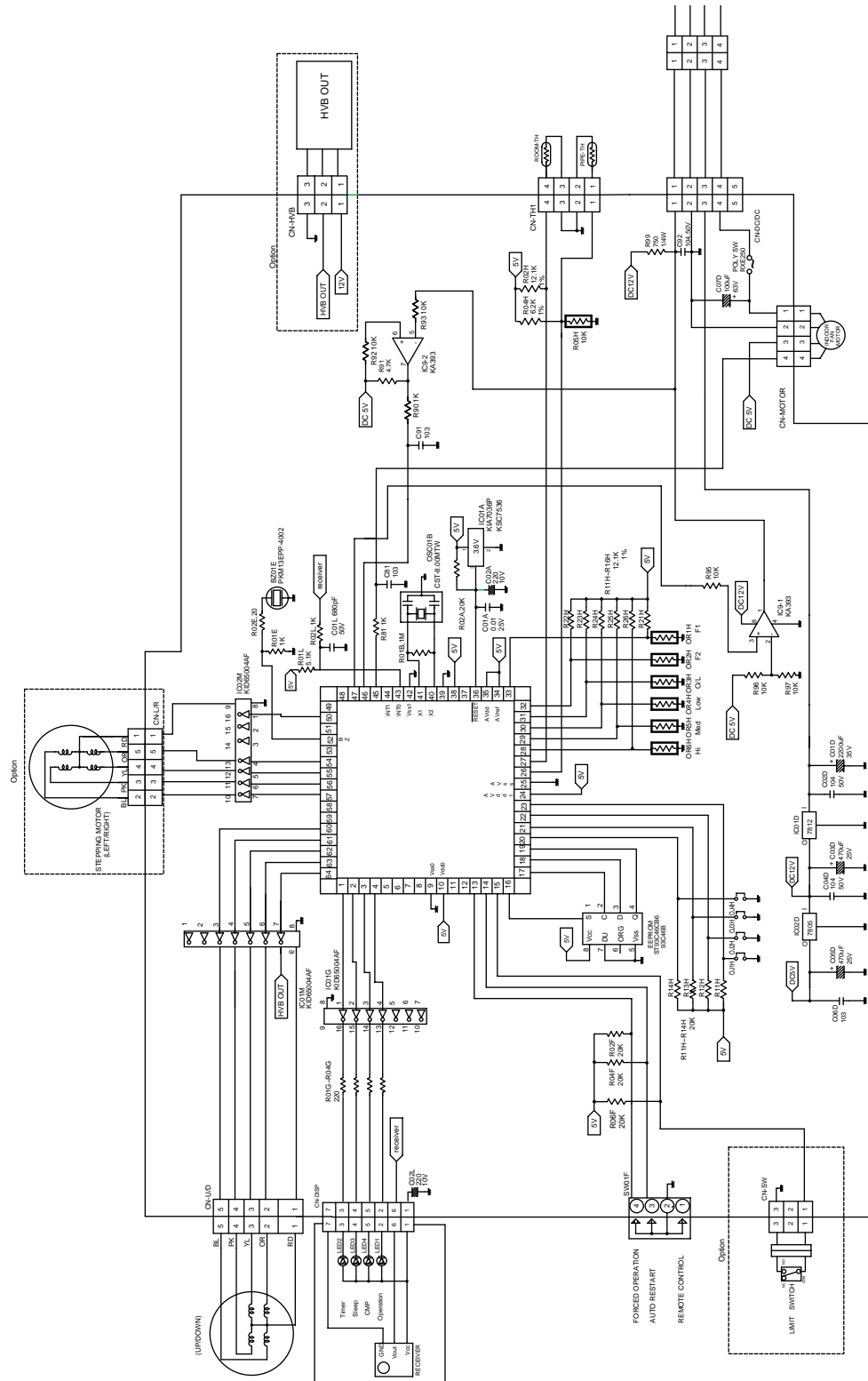

2. Outdoor Unit

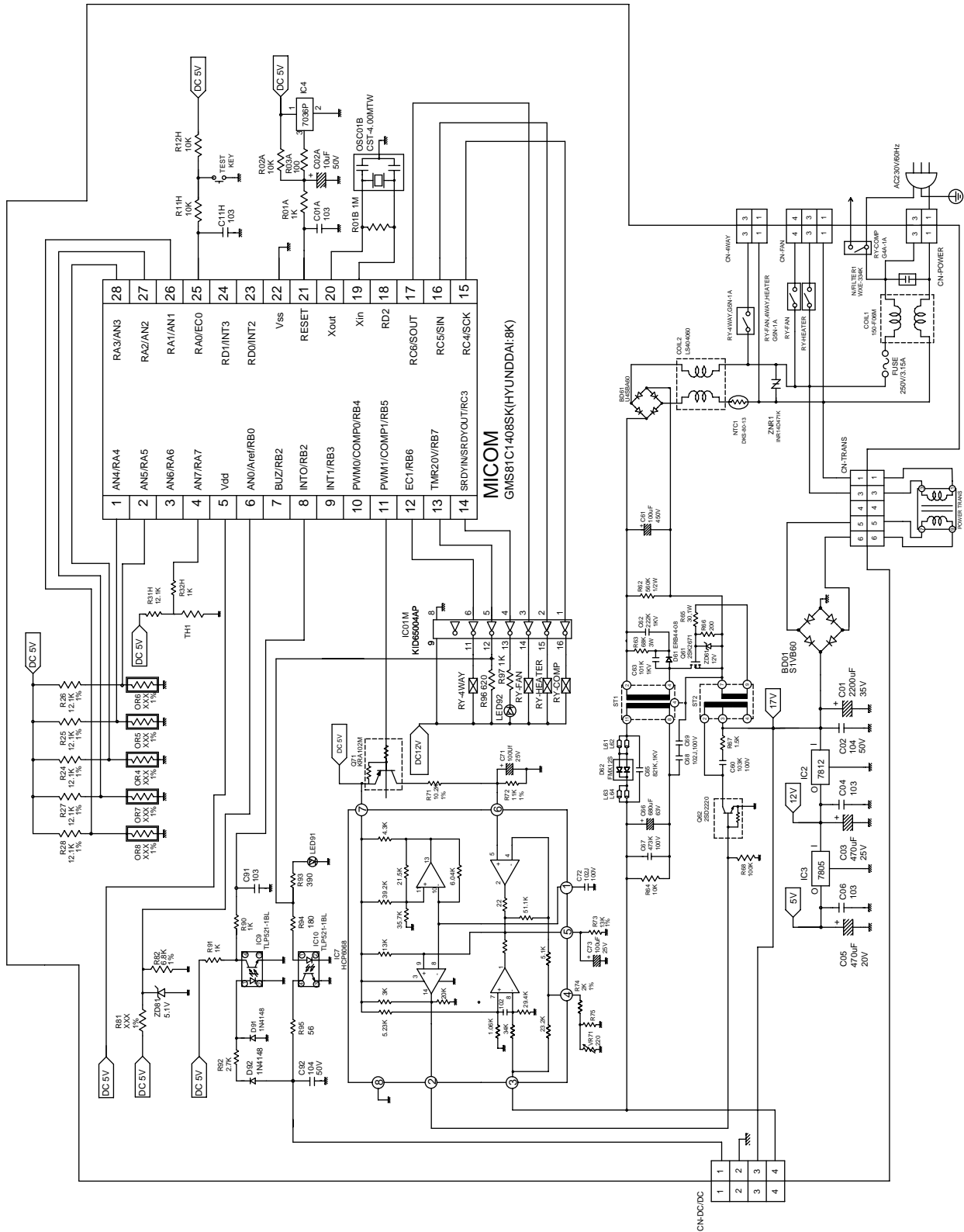

Exploded View and Replacement Parts List

1. Indoor Unit (9K)

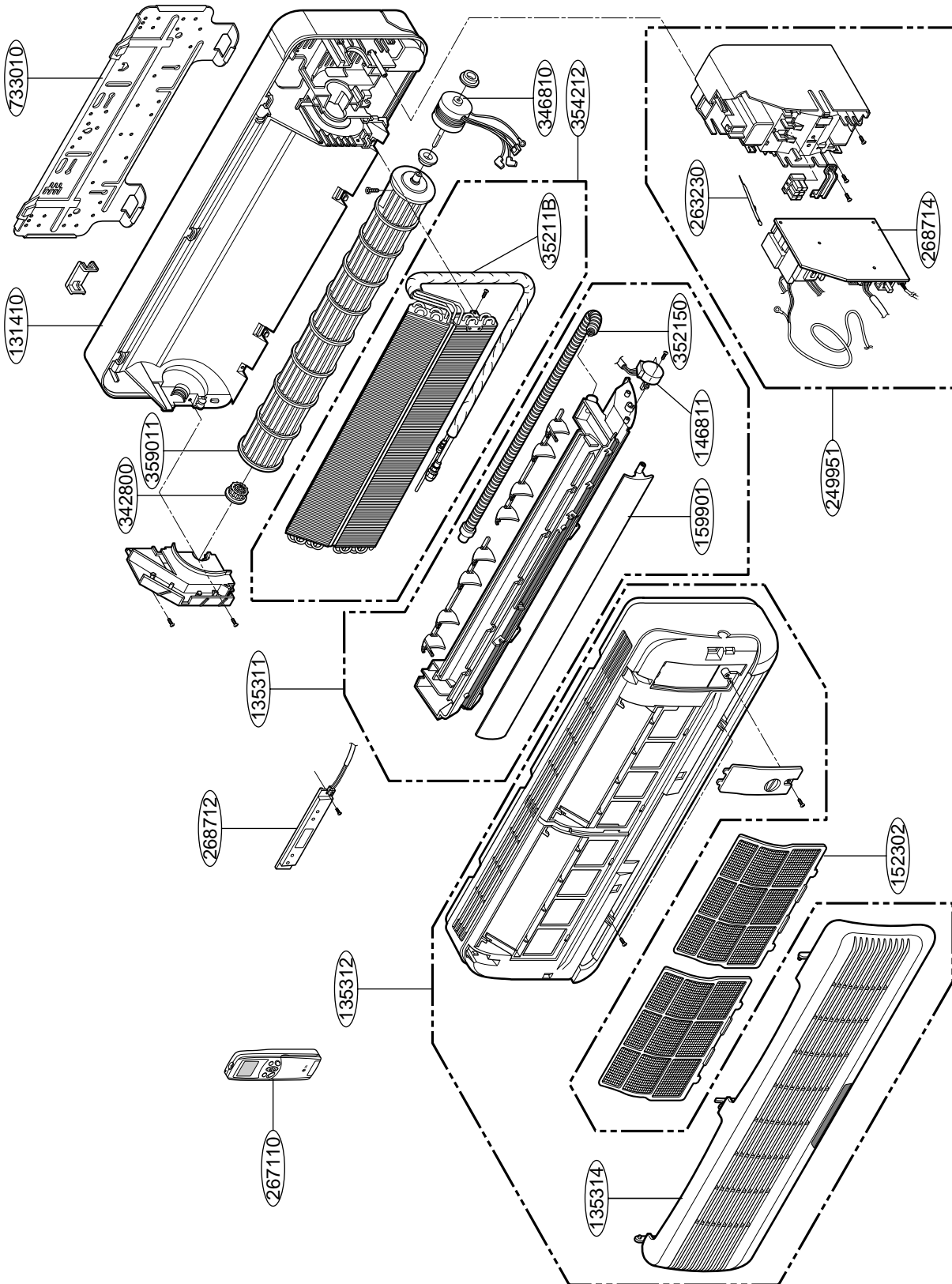

Parts List(9K)

LOCATION NO.	PART NAME	HEAT CONTROLLER PART NO	Q/TY	REMARK ("R" means service parts)
			B-HMC09AS	
131410	CHASSIS ASSY	2021-0188	1	R
135311	GRILLE ASSY,DISCHARGE(INDOOR)	2020-0033	1	R
135312	GRILLE ASSY,FRONT(INDOOR)	2020-0034	1	R
135314	GRILLE ASSY,INLET SUB	2020-0035	1	R
146811	MOTOR ASSY,STEP	2010-0029	1	R
152302	FILTER(MECH),A/C	2040-0123	1	R
159901	VANE,HORIZONTAL	2020-0036	1	R
249951	CONTROL BOX ASSY,INDOOR	2011-0039	1	R
263230	THERMISTOR ASSY	2014-0019	1	R
267110	REMOTE CONTROLLER ASSY	2019-0065	1	R
268712	PWB(PCB) ASSY,DISPLAY	2011-0040	1	R
268714	PWB(PCB) ASSY,MAIN	2011-0041	1	R
342800	BEARING	2052-0004	1	R
346810	MOTOR ASSY,DC	2010-0030	1	R
35211B	TUBE ASSY,TUBING	2035-0037	1	R
352150	HOSE ASSY,DRAIN	2040-0126	1	R
354212	EVAPORATOR ASSY,FINAL	2032-0027	1	R
359011	FAN ASSY,CROSS FLOW	2051-0021	1	R
733010	PLATE	2021-0187	1	R

2. Indoor Unit(12K)

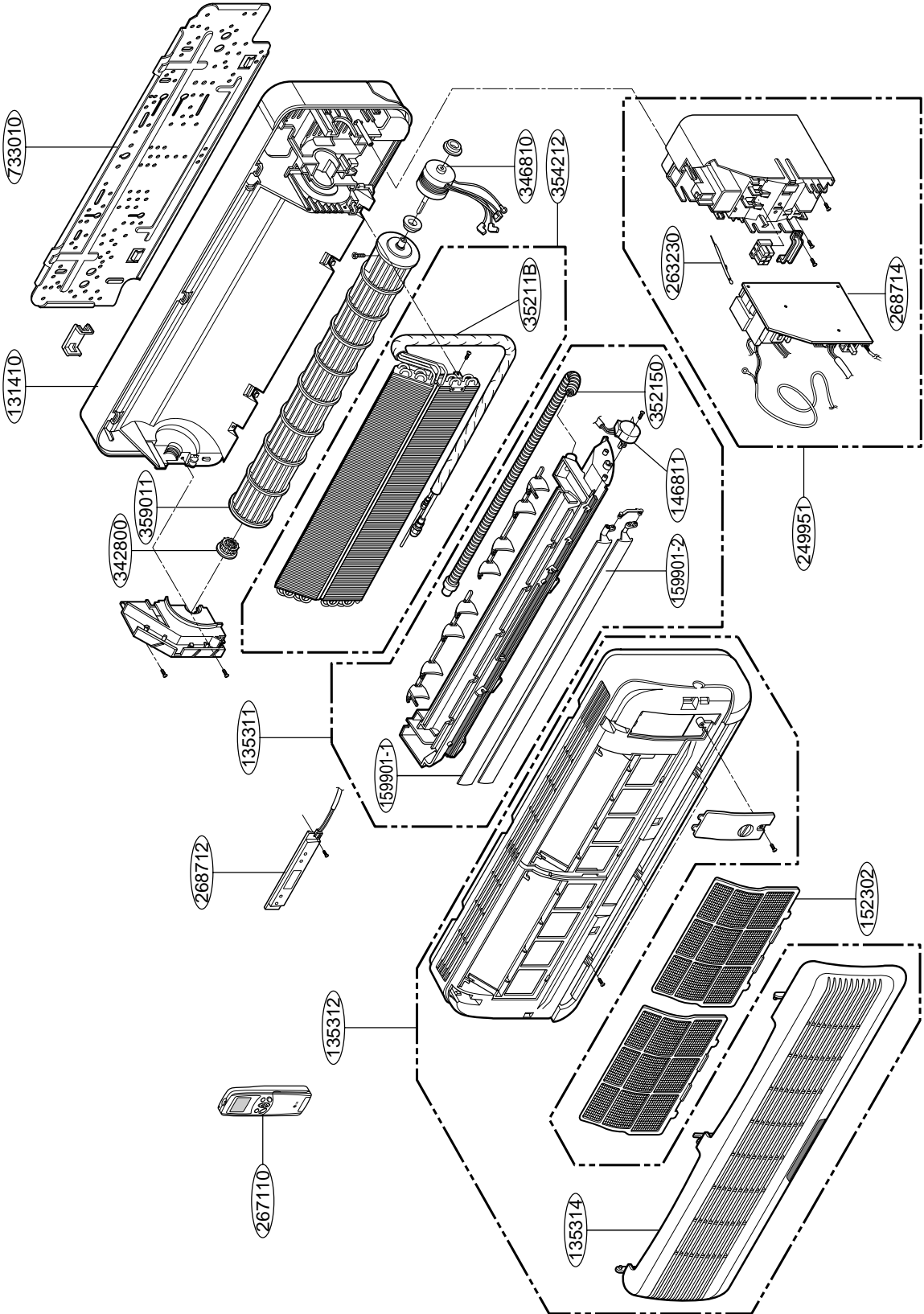

Parts List(12K)

LOCATION NO.	PART NAME	HEAT CONTROLLER PART NO	Q/TY		REMARK ("R" means service parts)
			B-HMC12AS	B-HMH12AS	
131410	CHASSIS ASSY	2021-0189	1	1	R
135311	GRILLE ASSY, DISCHARGE(INDOOR)	2020-0037	1	1	R
135312	GRILLE ASSY, FRONT	2020-0038	1		R
		2020-0039		1	R
135314	GRILLE ASSY, INLET	2020-0040	1		R
		2020-0041		1	R
146811	MOTOR ASSY, STEP	2010-0029	1	1	R
152302	FILTER(MECH),A/C	2040-0124	2	2	R
159901-1	VANE, HORIZONTAL	2020-0042	1	1	R
159901-2	VANE, HORIZONTAL	2020-0043	1	1	R
249951	CONTROL BOX ASSY, INDOOR	2011-0042	1		R
		2011-0043		1	R
263230	THERMISTOR ASSY	2014-0019	1	1	R
267110	REMOTE CONTROLLER ASSY	2019-0065	1		R
		2019-0066		1	R
268712	PWB(PCB) ASSY, DISPLAY	2011-0044	1	1	R
268714	PWB(PCB) ASSY, MAIN	2011-0045	1		R
		2011-0046		1	R
342800	BEARING	2052-0004	1	1	R
346810	MOTOR ASSY, DC	2010-0031	1	1	R
35211B	TUBE ASSY, TUBING	2035-0038	1	1	R
352150	HOSE ASSY, DRAIN	2040-0126	1	1	R
354212	EVAPORATOR ASSY, FINAL	2032-0028	1	1	R
359011	FAN ASSY, CROSS FLOW	2051-0022	1	1	R
733010	PLATE ASSY, INSTALL	2021-0001	1	1	R

3. Indoor Unit(18K, 24K)

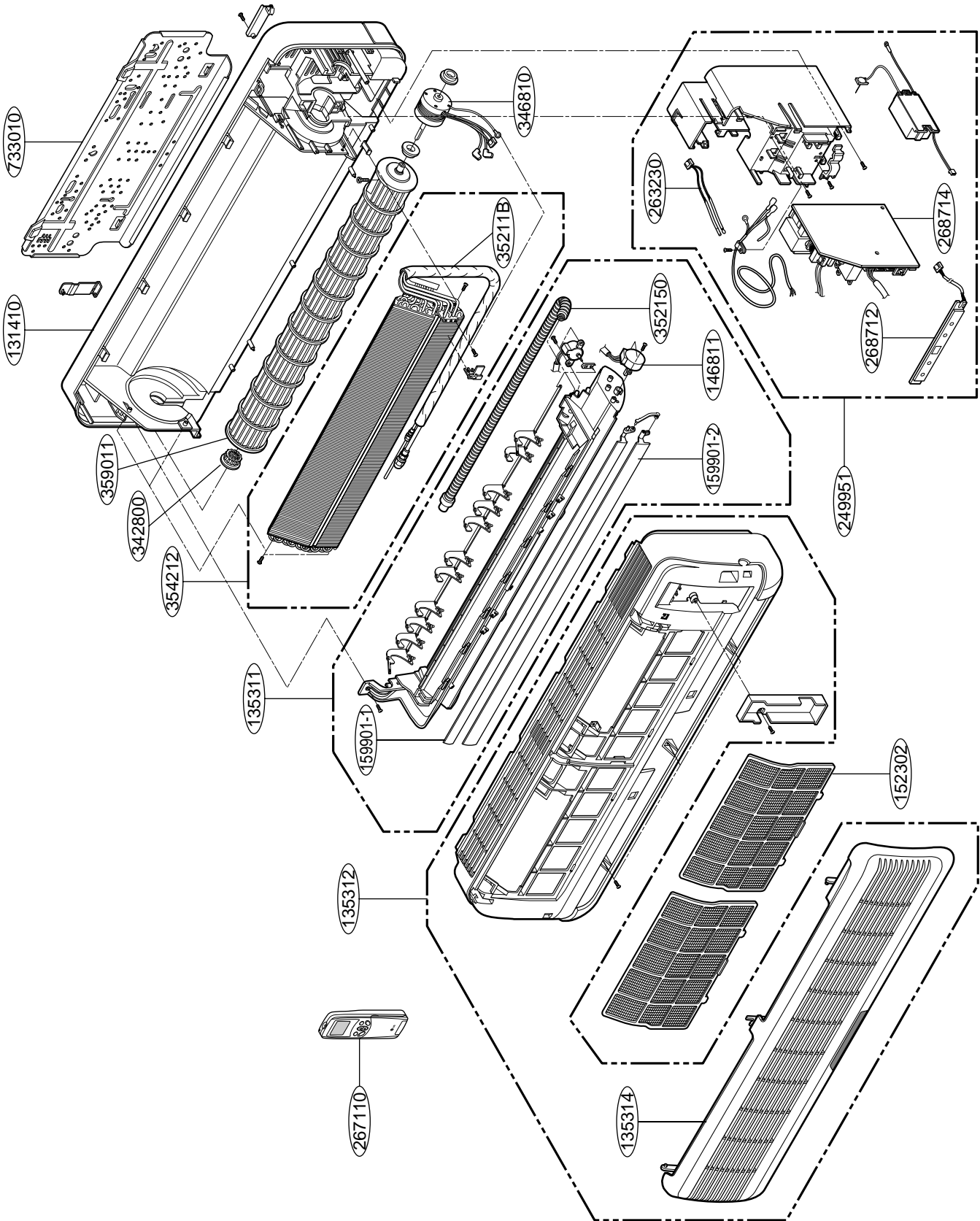

Parts List(18K, 24K)

LOCATION NO.	PART NAME	HEAT CONTROLLER PART NO	Q/TY				REMARK ("R" means service parts)
			B-HMC18AS	B-HMH18AS	B-HMC24AS	B-HMH24AS	
131410	CHASSIS ASSY	2021-0190	1	1	1	1	R
135311	GRILLE ASSY,DISCHARGE(INDOOR)	2020-0044	1	1	1	1	R
135312	GRILLE ASSY,FRONT(INDOOR)	2020-0045	1		1		R
		2020-0046		1		1	R
135314	GRILLE ASSY,INLET SUB	2020-0047	1		1		R
		2020-0048		1		1	R
146811	MOTOR ASSY,STEP	2010-0029	1	1	1	1	R
152302	FILTER(MECH),A/C	2040-0125	2	2	2	2	R
159901-1	VANE,HORIZONTAL	2020-0049	1	1	1	1	R
159901-2	VANE,HORIZONTAL	2020-0050	1	1	1	1	R
249951	CONTROL BOX ASSY,INDOOR	2011-0047	1				R
		2011-0048		1			R
		2011-0049			1		R
		2011-0050				1	R
263230	THERMISTOR ASSY	2014-0019	1	1	1	1	R
267110	REMOTE CONTROLLER ASSY	2019-0065	1		1		R
		2019-0066		1		1	R
268712	PWB(PCB) ASSY,DISPLAY	2011-0051	1	1	1	1	R
268714	PWB(PCB) ASSY,MAIN	2011-0052	1				R
		2011-0053		1			R
		2011-0054			1		R
		2011-0055				1	R
342800	BEARING	2052-0004	1	1	1	1	R
346810	MOTOR ASSY,DC	2010-0032	1	1	1	1	R
35211B	TUBE ASSY,TUBING	2035-0039	1	1			R
		2035-0040			1	1	R
352150	HOSE ASSY,DRAIN	2040-0126	1	1	1	1	R
354212	EVAPORATOR ASSY,FINAL	2032-0029	1				R
		2032-0030		1			R
		2032-0031			1	1	R
359011	FAN ASSY,CROSS FLOW	2051-0023	1		1		R
		2051-0024		1		1	R
733010	PLATE ASSY,INSTALL	2021-0001	1	1	1	1	R

4. Outdoor Unit(9K, 12K)

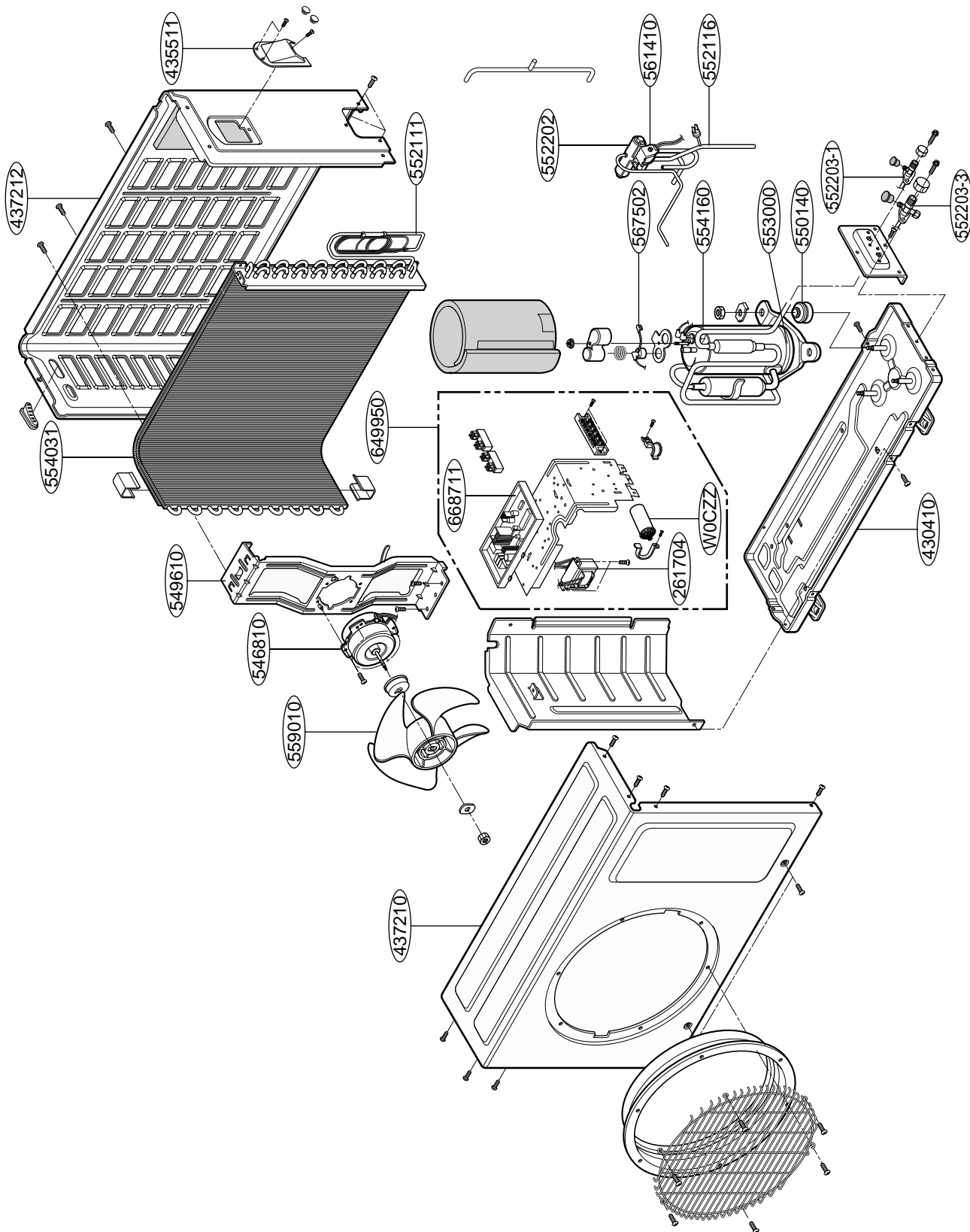

Parts List(9K, 12K)

LOCATION NO.	PART NAME	HEAT CONTROLLER PART NO	Q/TY			REMARK ("R" means service parts)
			A-HMC09AS	A-HMC12AS	A-HMH12AS	
552116	TUBE ASSY,REVERSING	2035-0034			1	R
552202	VALVE,REVERSING	2034-0001			1	R
552203-1	VALVE,SERVICE	2033-0012	1			R
		2033-0013		1	1	R
552203-3	VALVE,SERVICE	2033-0009	1			R
		2033-0010		1	1	R
553000	HEATER,SUMP	2019-0007			1	R
554031	CONDENSER ASSY,BENT	2031-0019		1		R
		2031-0025			1	R
		2031-0020	1			R
554160	COMPRESSOR SET	2030-0020		1		R
		2030-0021	1			R
		2030-0022			1	R
559010	FAN ASSY,PROPELLER	2050-0007	1	1	1	R
561410	COIL ASSY,REVERSING VALVE	2034-0012			1	R
567502	O.L.P	2019-0012		1		R
		2019-0023	1			R
		2019-0062			1	R
649950	CONTROL BOX ASSY,OUTDOOR	2011-0025	1			R
		2011-0026		1		R
		2011-0027			1	R
668711	PWB(PCB) ASSY,MAIN(OUTDOOR)	2011-0032	1			R
		2011-0033		1		R
		2011-0034			1	R
W0CZZ	CAPACITOR,DRAWING	2013-0019		1		R
		2013-0020			1	R
		2013-0021	1			R
552111	TUBE ASSY,CAPILLARY	2035-0027		1		R
		2035-0028			1	R
		2035-0029	1			R
261704	TRANSFORMER,POWER	2012-0003	1	1		R
430410	BASE ASSY,OUTDOOR	2021-0175	1	1		R
		2021-0176			1	R
435511	COVER ASSY,CONTROL(OUTDOOR)	2021-0179	1	1	1	R
437210	PANEL ASSY,FRONT(OUTDOOR)	2021-0182	1	1	1	R
437212	PANEL ASSY,REAR(OUTDOOR)	2021-0184	1	1		R
		2021-0185			1	R
546810	MOTOR ASSY,OUTDOOR	2010-0026	1	1	1	R
550140	ISOLATOR,COMP	2040-0042	3	3	3	R

5. Outdoor Unit(18K)

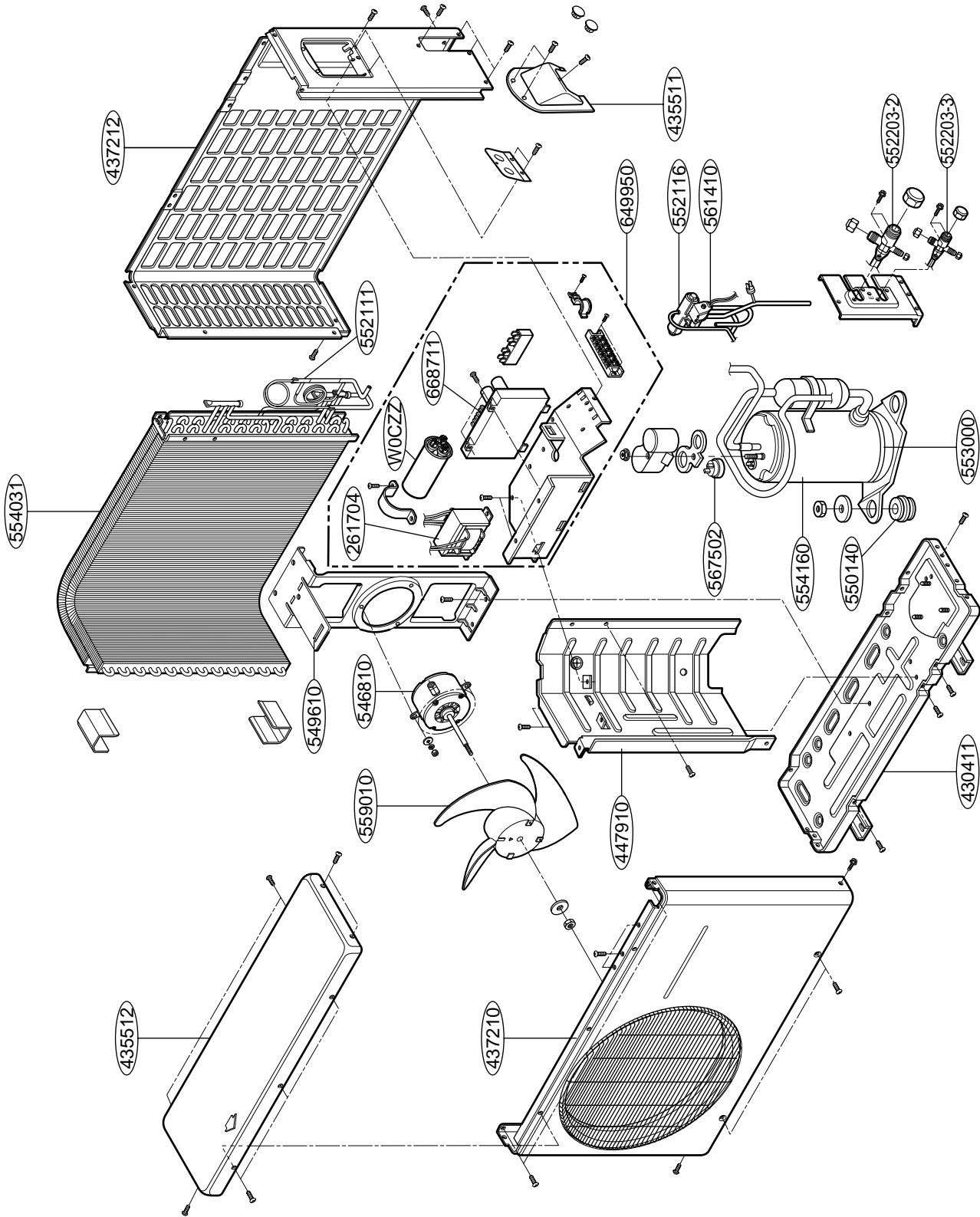

Parts List(18K)

LOCATION NO.	PART NAME	HEAT CONTROLLER PART NO	Q/TY		REMARK ("R" means service parts)
			A-HMC18AS	A-HMH18AS	
261704	TRANSFORMER, POWER	2012-0018	1	1	R
430411	BASE ASSY,WELD[OUTDOOR]	2021-0177	1	1	R
435511	COVER ASSY,CONTROL(OUTDOOR)	2021-0180	1	1	R
435512	COVER ASSY,TOP(OUTDOOR)	2021-0181	1	1	R
437210	PANEL ASSY,FRONT(OUTDOOR)	2021-0183	1	1	R
437212	PANEL ASSY,REAR	2021-0186	1	1	R
546810	MOTOR ASSY,OUTDOOR	2010-0027	1	1	R
550140	ISOLATOR,COMP	2040-0042	3	3	R
552111	TUBE ASSY,CAPILLARY	2035-0030	1		R
		2035-0031		1	R
552116	TUBE ASSY,REVERSING	2035-0035		1	R
552202	VALVE,REVERSING	2034-0004		1	R
552203-2	VALVE,SERVICE	2033-0005	1	1	R
552203-3	VALVE,SERVICE	2033-0001	1		R
		2033-0011		1	R
553000	HEATER,SUMP	2019-0009		1	R
554031	CONDENSER ASSY,BENT	2031-0021	1		R
		2031-0024		1	R
554160	COMPRESSOR SET	2030-0023	1		R
		2030-0024		1	R
559010	FAN ASSY,PROPELLER	2050-0001	1	1	R
561410	COIL ASSY,REVERSING VALVE	2034-0003		1	R
567502	O.L.P	2019-0064	1		R
649950	CONTROL BOX ASSY,OUTDOOR	2011-0028	1		R
		2011-0029		1	R
668711	PWB(PCB) ASSY,MAIN(OUTDOOR)	2011-0035	1		R
		2011-0036		1	R
W0CZZ	CAPACITOR,DRAWING	2013-0022	1		R
		2013-0001		1	R

6. Outdoor Unit(24K)

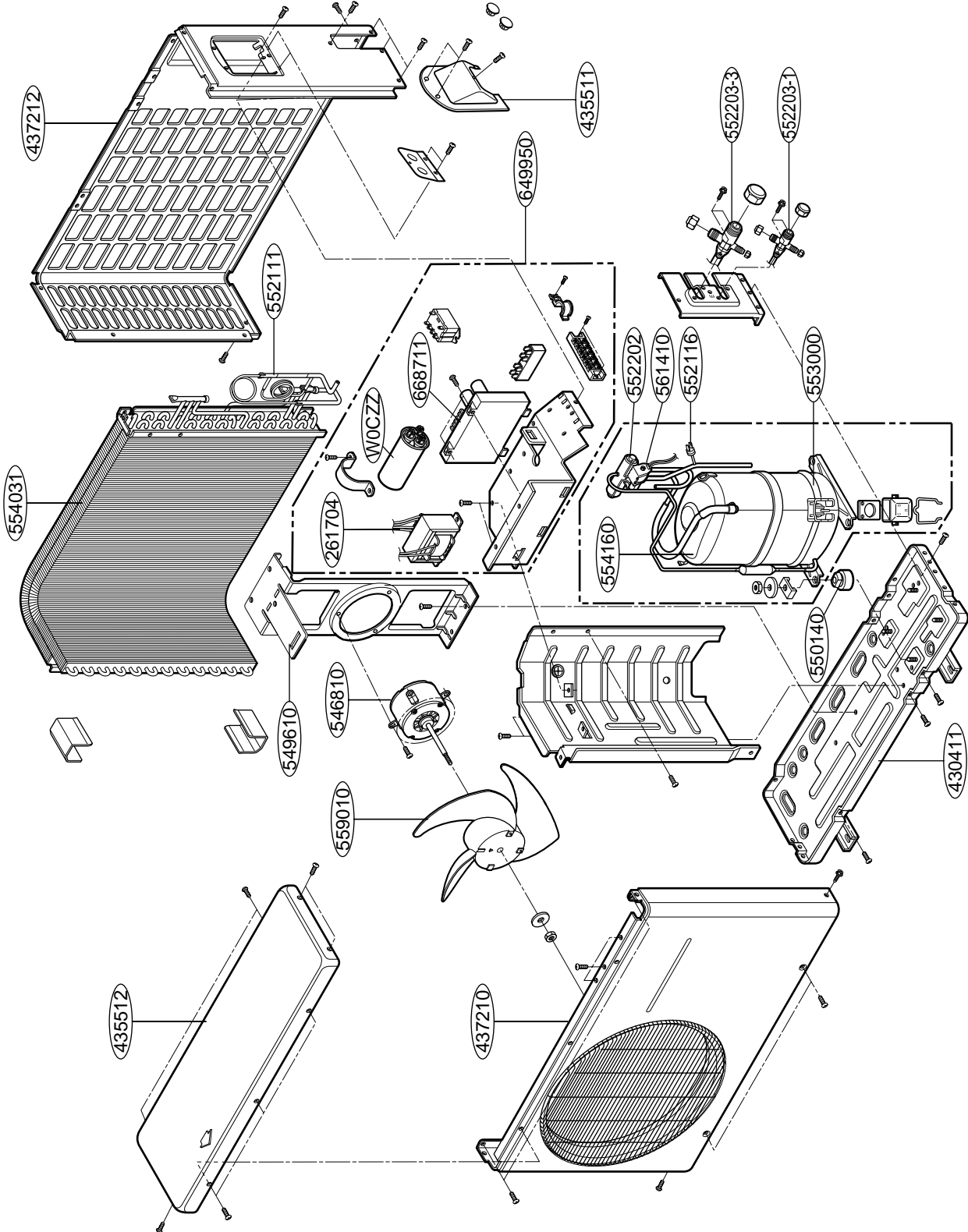

Parts List(24K)

LOCATION NO.	PART NAME	HEAT CONTROLLER PART NO	Q/TY		REMARK ("R" means service parts)
			A-HMC24AS	A-HMH24AS	
261704	TRANSFORMER,POWER	2012-0002	1	1	R
430411	BASE ASSY,WELD[OUTDOOR]	2021-0178	1	1	R
435511	COVER ASSY,CONTROL(OUTDOOR)	2021-0180	1	1	R
435512	COVER ASSY,TOP(OUTDOOR)	2021-0181	1	1	R
437210	PANEL ASSY,FRONT(OUTDOOR)	2021-0183	1	1	R
437212	PANEL ASSY,REAR	2021-0186	1	1	R
546811	MOTOR ASSY,OUTDOOR	2010-0028	1	1	R
550140	ISOLATOR,COMP	2040-0121	3		R
		2040-0122		3	R
552111	TUBE ASSY,CAPILLARY	2035-0032	1		R
		2035-0033		1	R
552116	TUBE ASSY,REVERSING	2035-0036		1	R
552202	VALVE,REVERSING	2034-0004		1	R
552203-1	VALVE,SERVICE	2033-0004	1	1	R
552203-3	VALVE,SERVICE	2033-0005	1	1	R
553000	HEATER,SUMP	2019-0009		1	R
554031	CONDENSER ASSY,BENT	2031-0022	1		R
		2031-0023		1	R
554160	COMPRESSOR ASSY,FINAL	2030-0025	1	1	R
559010	FAN ASSY,PROPELLER	2050-0001	1	1	R
561440	COIL ASSY,REVERSING VALVE	2034-0003		1	R
649950	CONTROL BOX ASSY,OUTDOOR	2011-0030	1		R
		2011-0031		1	R
668711	PWB(PCB) ASSY,MAIN(OUTDOOR)	2011-0037	1		R
		2011-0038		1	R
W0CZZ	CAPACITOR,DRAWING	2013-0023	1	1	R

Specifications and performance data subject to change without notice.

HEAT CONTROLLER, INC.

1900 WELLWORTH AVENUE • JACKSON, MICHIGAN 49203

THE QUALITY LEADER IN CONDITIONING AIR