

This Owner's Manual is provided and hosted by [Appliance Factory Parts](#).



# Weber SUMMIT E-420 LP (2008) Owner's Manual

[Shop genuine replacement parts for Weber SUMMIT  
E-420 LP \(2008\)](#)



[Find Your Weber Grill Parts - Select From 2037 Models](#)

----- Manual continues below -----

# **SUMMIT<sup>®</sup>**

## **GAS GRILL**

### **LP Gas Grill Owner's Guide**

**Guía del propietario del asador de gas licuado de propano - Pg 56**

**Guide de l'utilisateur du grill à gaz PL - Pg 57**

**Assembly, Ensamblaje, Assemblage - Pg 9**

**E/S-420/450**

**#89559**

**YOU MUST READ THIS OWNER'S GUIDE  
BEFORE OPERATING YOUR GAS GRILL**

**⚠ DANGER**

**If you smell gas:**

- 1. Shut off gas to the appliance.**
- 2. Extinguish any open flames.**
- 3. Open lid.**
- 4. If odor continues, keep away from the appliance and immediately call your gas supplier or your fire department.**

**Leaking gas may cause a fire or explosion which can cause serious bodily injury or death, or damage to property.**

**⚠ WARNING: Follow all procedures carefully to barbecue operation. Barbecue was dealer's responsibility.**

**NOTICE TO INSTALLER: Instructions must be left with the owner. The owner should keep them for future reference.**

**THIS GAS APPLIANCE IS FOR  
OUTDOOR USE ONLY.**

**⚠ WARNING: Do not try to operate the appliance without reading the instructions.**

## ⚠ DANGER

Failure to follow the Dangers, Warnings and Cautions contained in this Owner's Manual may result in death, or in a fire or an explosion causing damage to property.







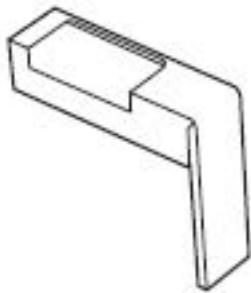

## ⚠ WARNINGS

- ⚠ Do not store a spare or disconnected liquid propane cylinder under or near this barbecue.
- ⚠ Improper assembly may be dangerous. Please follow the assembly instructions carefully.
- ⚠ After a period of storage, and/or nonuse, the Weber® gas barbecue should be checked for gas leaks before use. See instructions in this manual for correct procedures.
- ⚠ Do not operate the Weber® gas barbecue if there is a gas leak present.
- ⚠ Do not use a flame to check for gas leaks.
- ⚠ Combustible materials should never be within 24 inches (61 cm) of the back or sides of your Weber® gas barbecue.
- ⚠ Do not put a barbecue cover or anything flammable on, or in the storage area under the barbecue.
- ⚠ Your Weber® gas barbecue should never be used by children. Accessible parts of the barbecue should be kept away from children while it is in use.
- ⚠ You should exercise reasonable care when operating your Weber® gas barbecue. It will be hot and should never be left unattended, or moved while in operation.
- ⚠ Should the burners go out while in operation, turn all gas valves off. Open the lid and wait five minutes before relighting, using the lighting instructions.
- ⚠ Do not use charcoal or lava rock in your Weber® gas barbecue.
- ⚠ Never lean over open grill or place hands or fingers on the front edge of the cooking box.
- ⚠ Should a grease fire occur, turn off all burners and leave lid closed until fire is out.
- ⚠ Do not enlarge valve orifices or burner ports when cleaning the valves or burners.
- ⚠ The Weber® gas barbecue should be thoroughly cleaned on a regular basis.
- ⚠ Liquid propane gas is not natural gas. The conversion or attempted use of natural gas in a liquid propane gas unit is dangerous and will void your warranty.
- ⚠ Do not attempt to disconnect any gas fitting while your barbecue is in operation.
- ⚠ Use heat-resistant barbecue mitts or gloves when operating barbecue.
- ⚠ Keep any electrical supply cord and the fuel supply hose away from any heated surfaces.
- ⚠ Combustion byproducts produced when using this product contain chemicals known to the State of California to cause cancer, birth defects, or other reproductive harm.
- ⚠ Do not use this barbecue unless all parts are in place. The unit must be properly assembled according to the instructions.
- ⚠ Do not build this model of grill in any built-in or slide in construction. Ignoring this Warning can result in a fire that can damage property and cause serious bodily injury or death.
- ⚠ Proposition 65 Warning: Handling the brass material on this product exposes you to lead, a chemical known to the State of California to cause cancer, birth defects or other reproductive harm.  
(Wash hands after handling this product.)

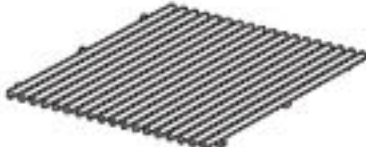
## LIQUID PROPANE GAS UNITS ONLY:

- ⚠ Use the pressure regulator and hose assembly that is supplied with your Weber® gas barbecue.
- ⚠ Do not attempt to disconnect the gas regulator and hose assembly or any gas fitting while your barbecue is in operation.
- ⚠ A dented or rusty liquid propane cylinder may be hazardous and should be checked by your local fire department. Do not use a liquid propane cylinder with a damaged valve.
- ⚠ Although your liquid propane cylinder may appear to be empty, gas may still be present, and should be properly transported and stored accordingly.
- ⚠ If you see, smell or hear the hiss of escaping gas from the liquid propane cylinder:
  1. Move away from liquid propane cylinder.
  2. Do not attempt to correct the problem yourself.
  3. Call your fire department.

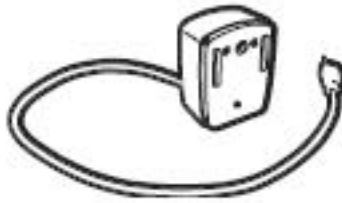

	420	450		
<b>Catch Pan Holder</b> Sostenedor del plato recolector Support de l'égouttoir	1	1		<b>Drip Tray</b> Bandeja de goteo Plateau de recueil des gouttes
<b>Catch Pan</b> Plato recolector Egouttoir	1	1		<b>Flavorizer® Bar</b> Barras Flavorizer® Barre Flavorizer®
<b>Cooking Grate</b> Parrilla de cocción Grille de cuisson	2	2		<b>Smoker Bar</b> Barra del ahumador Barre du fumoir
<b>Warming Rack</b> Rejilla para calentar Grille de maintien au chaud	1	1		<b>Smoker Box</b> Caja del ahumador Boîtier du fumoir
<b>Rotisserie Fork</b> Horquilla del asador giratorio Fourche de la rôtissoire	-	4		<b>Side Burner Table</b> Mesa del quemador lateral Tablette du brûleur latéral
<b>Rotisserie Spit</b> Espetón del asador giratorio Brôche de la rôtissoire	-	1		<b>Side Table</b> Mesa lateral Tablette latérale
<b>Rotisserie Motor</b> Motor del asador giratorio Moteur de la rôtissoire	-	1		<b>Wrench</b> Llave Clé
<b>Rotisserie Bracket</b> Soporte del asador giratorio Support de la rôtissoire	-	1		<b>Nylon Washer</b> Arandela de nilón Rondelle de nylon
			<b>Truss Head Screw (1/4-20 x 1 inch)</b> Tornillo de cabeza segmentada (Tornillo 1/4-20 x 1 pulgadas) Vis à tête bombée large de (1/4-20 x 1 pouces)	
			<b>Keps Nut (1/4-20 keps nut)</b>	

# EXPLODED VIEW E/S-420

VISION ÉCLATÉE, DIAGRAMA DE DESPIECE

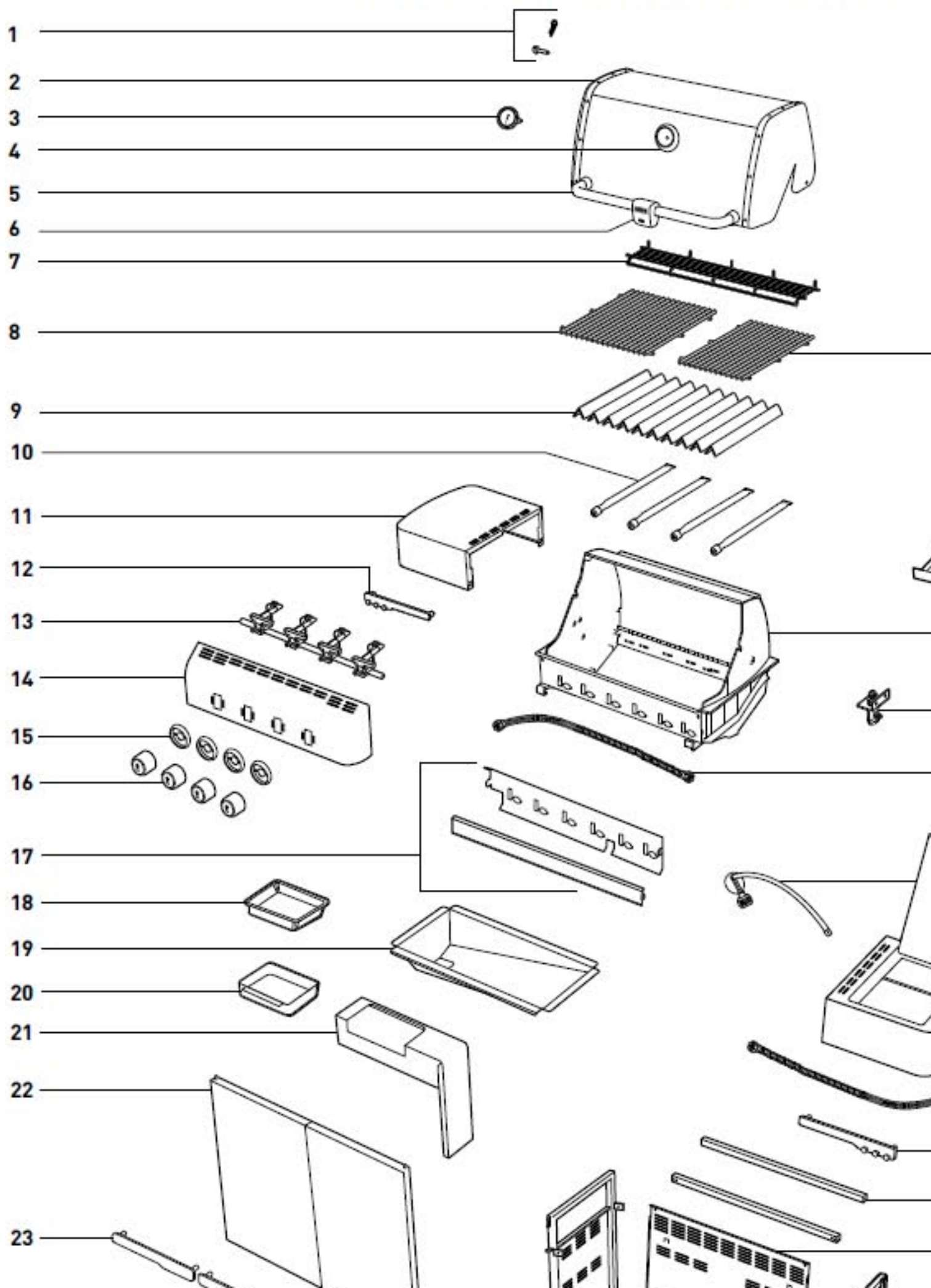

## LISTA DEL DIAGRAMA DE DESPIECE, LISTE DE LA VISION

- |   |  |  |
|---|--|--|
| 1. <b>Shroud Hardware</b><br>Accesorios de la cubierta<br>Structure de protection                     | 18. <b>Disposable Drip Pan</b><br>Bandeja de goteo desechable<br>Egouttoir jetable     | 35. <b>Side Manifold</b><br>Múltiple<br>Tuyau                      |
| 2. <b>Shroud</b><br>Cubierta<br>Tôle de protection  | 19. <b>Drip Tray</b><br>Bandeja de goteo<br>Plateau-égouttoir                          | 36. <b>Right Side Panel</b><br>Panel lateral derecho<br>Supplément |
| 3. <b>Thermometer</b><br>Termómetro<br>Thermomètre  | 20. <b>Catch Pan</b><br>Plato recolector<br>Egouttoir                                  | 37. <b>Frame</b><br>Bastidor<br>Supplément                         |
| 4. <b>Thermometer Bezel</b><br>Moldura decorativa del termómetro<br>Plaque indicatrice du thermomètre | 21. <b>Catch Pan Holder</b><br>Soporte del plato recolector<br>Support d'égouttoir     | 38. <b>Back Panel</b><br>Panel posterior<br>Panneau                |
| 5. <b>Handle</b><br>Asa<br>Poignée  | 22. <b>Left Door</b><br>Puerta izquierda<br>Porte gauche                               | 39. <b>Right Side Panel</b><br>Panel lateral derecho<br>Panneau    |
| 6. <b>Grill Out™ Handle Light</b><br>Luz de asa Grill Out™<br>Lampe de poignée Grill Out™             | 23. <b>Door Handles</b><br>Asas de las puertas<br>Poignées de portes                   | 40. <b>Top Panel</b><br>Panel superior<br>Plaque                   |
| 7. <b>Warming Rack</b><br>Rejilla de calentamiento<br>Grille de réchauffage                           | 24. <b>Right Door</b><br>Puerta derecha<br>Porte droite                                | 41. <b>Top Panel</b><br>Panel superior<br>Desplazable<br>Glissière |
| 8. <b>Cooking Grates</b><br>Parrillas de cocción<br>Grilles de cuisson                                | 25. <b>Left Frame Panel</b><br>Panel izquierdo del bastidor<br>Panneau du cadre gauche | 42. <b>Material</b><br>Material<br>Porte                           |
| 9. <b>Flavorizer® Bars</b><br>Barras Flavorizer®<br>Barres Flavorizer®                                | 26. <b>Bottom Panel</b><br>Panel inferior<br>Panneau inférieur                         | 43. <b>Castor</b><br>Rueda<br>Roulette                             |
| 10. <b>Burner Tubes</b><br>Tubos quemadores<br>Tubes des brûleurs                                     | 27. <b>Cooking Grate</b><br>Rejilla de cocción<br>Grille de cuisson                    | 44. <b>Lock</b><br>Cerradura<br>Roulette                           |
| 11. <b>Side Table</b><br>Mesa lateral<br>Tablette latérale  | 28. <b>Side Burner</b><br>Quemador lateral<br>Brûleur latéral                          |  |
| 12. <b>Left Tool Holder</b><br>Portaherramientas izquierdo<br>Support d'ustensiles de gauche          | 29. <b>Cookbox</b><br>Caja de cocción<br>Boîtier de cuisson                            |  |
| 13. <b>Manifold</b><br>Múltiple<br>Collecteur   | 30. <b>Bulkhead</b><br>Tabique divisorio<br>Cloison                                    |  |
| 14. <b>Control Panel</b><br>Tablero de control<br>Panneau de commandes                                | 31. <b>Manifold Hose</b><br>Manguera del múltiple                                      |  |

# EXPLODED VIEW E/S-450

## VISION ÉCLATÉE, DIAGRAMA DE DESPIECE

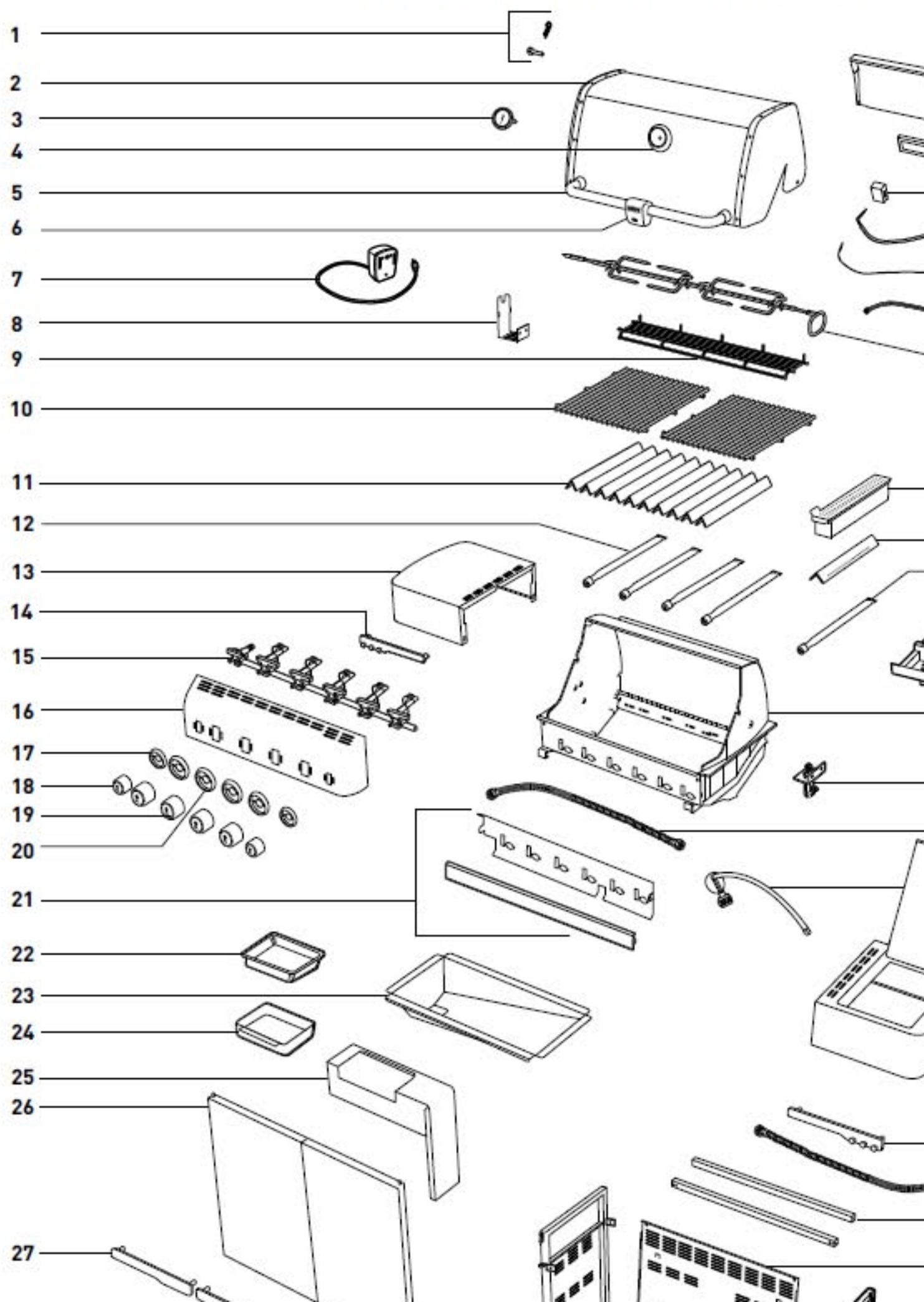

## LISTA DEL DIAGRAMA DE DESPIECE, LISTE DE LA VISION E

- |   |   |                                  |
|---|---|----------------------------------|
| 1. <b>Shroud Hardware</b><br>Accesorios de la cubierta<br>Structure de protection                     | 21. <b>Water Baffle / Heat Shield</b><br>Reflector de agua / Pantalla térmica<br>Protection contre l'eau/Cloison anti-chaleur | 41. <b>Side</b><br>Que<br>Brûl   |
| 2. <b>Shroud</b><br>Cubierta<br>Tôle de protection  | 22. <b>Disposable Drip Pan</b><br>Bandeja de goteo desechable<br>Egouttoir jetable  | 42. <b>Coo</b><br>Caja<br>Boîti  |
| 3. <b>Thermometer</b><br>Termómetro<br>Thermomètre  | 23. <b>Drip Tray</b><br>Bandeja de goteo<br>Plateau-égouttoir   | 43. <b>Bulk</b><br>Tabi<br>Clois |
| 4. <b>Thermometer Bezel</b><br>Moldura decorativa del termómetro<br>Plaque indicatrice du thermomètre | 24. <b>Catch Pan</b><br>Plato recolector<br>Egouttoir   | 44. <b>Man</b><br>Man<br>Tuya    |
| 5. <b>Handle</b><br>Asa<br>Poignée  | 25. <b>Catch Pan Holder</b><br>Soporte del plato recolector<br>Support d'égouttoir  | 45. <b>Hos</b><br>Man<br>Tuya    |
| 6. <b>Grill Out™ Handle Light</b><br>Luz de asa Grill Out™<br>Lampe de poignée Grill Out™             | 26. <b>Left Door</b><br>Puerta izquierda<br>Porte gauche  | 46. <b>Side</b><br>Tapa<br>Couv  |
| 7. <b>Rotisserie Motor</b><br>Motor del asador<br>Moteur de la rôtissoire                             | 27. <b>Door Handles</b><br>Asas de las puertas<br>Poignées de portes  | 47. <b>Side</b><br>Mes<br>Table  |
| 8. <b>Rotisserie Bracket</b><br>Soporte del asador giratorio<br>Support de la rôtissoire              | 28. <b>Right Door</b><br>Puerta derecha<br>Porte droite   | 48. <b>Righ</b><br>Port<br>Supp  |
| 9. <b>Warming Rack</b><br>Rejilla de calentamiento<br>Grille de réchauffage                           | 29. <b>Left Frame Panel</b><br>Panel izquierdo del bastidor<br>Panneau du cadre gauche  | 49. <b>Side</b><br>Man<br>Tuya   |
| 10. <b>Cooking Grates</b><br>Parrillas de cocción<br>Grilles de cuisson                               | 30. <b>Bottom Panel</b><br>Panel inferior<br>Panneau inférieur  | 50. <b>Fran</b><br>Sop<br>Supp   |
| 11. <b>Flavorizer® Bars</b><br>Barras Flavorizer®<br>Barres Flavorizer®                               | 31. <b>IR Burner Cover</b><br>Tapa del quemador IR<br>Cache du brûleur IR   | 51. <b>Back</b><br>Pant<br>Pant  |
| 12. <b>Burner Tubes</b><br>Tubos quemadores<br>Tubes des brûleurs                                     | 32. <b>Infrared Burner</b><br>Quemador infrarrojo<br>Brûleur à infrarouge   | 52. <b>Righ</b><br>Pant<br>Pant  |
| 13. <b>Side Table</b><br>Mesa lateral<br>Tablette latérale  | 33. <b>IR Burner Box</b><br>Caja del quemador infrarrojo<br>Boîtier du brûleur IR   | 53. <b>Tank</b><br>Básc<br>Plate |
| 14. <b>Left Tool Holder</b><br>Portaherramientas izquierdo<br>Support d'ustensiles de gauche          | 34. <b>IR Burner Igniter Wire</b><br>Cable de encendido del quemador IR<br>Câble de l'allumeur du brûleur IR                  | 54. <b>Tank</b><br>Desl<br>Gliss |
| 15. <b>Manifold</b><br>Múltiple<br>Collecteur   | 35. <b>Thermocouple</b><br>Termopar<br>Thermocouple   | 55. <b>Mat</b><br>Port<br>Port   |
| 16. <b>Control Panel</b><br>Tablero de control<br>Panneau de commandes                                | 36. <b>IR Burner Hose</b><br>Manguera del quemador IR<br>Tuyau du brûleur IR  | 56. <b>Cas</b><br>Rue<br>Roul    |

# ASSEMBLY, ASSEMBLAGE, ENSAMBLAJE

- Adjust doors, if necessary
- Si fuese necesario, ajuste la puerta
- Ajustez la porte si nécessaire

1

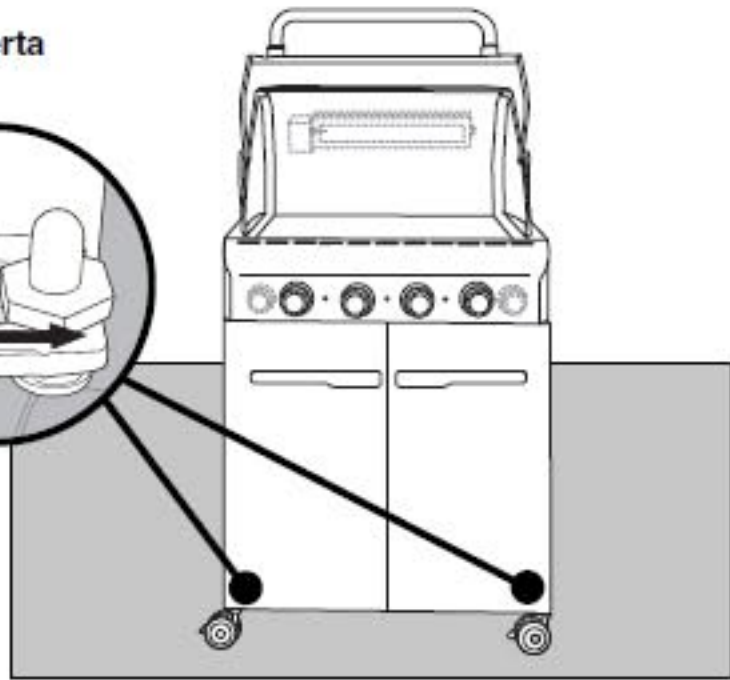
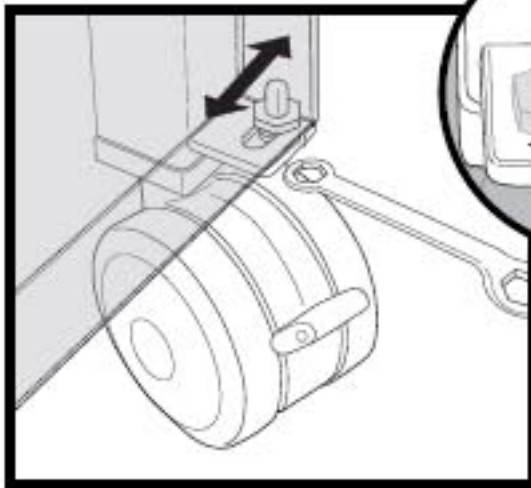

2

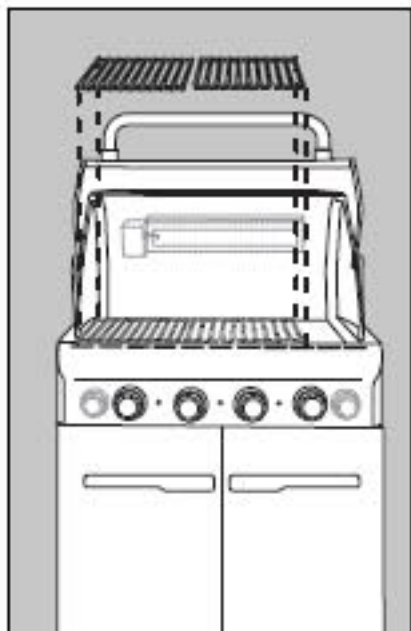

3

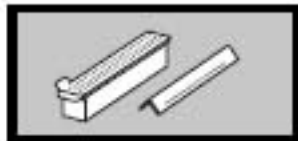

E/S-450

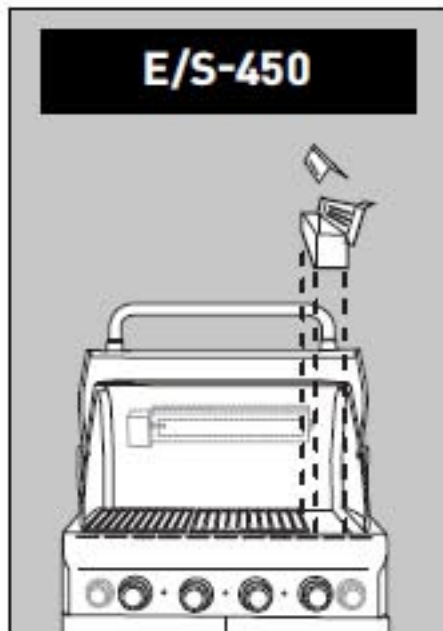

4

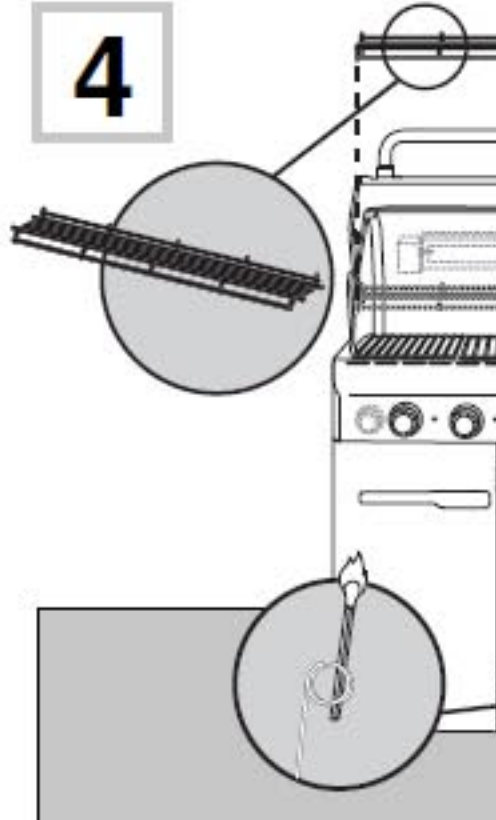

5

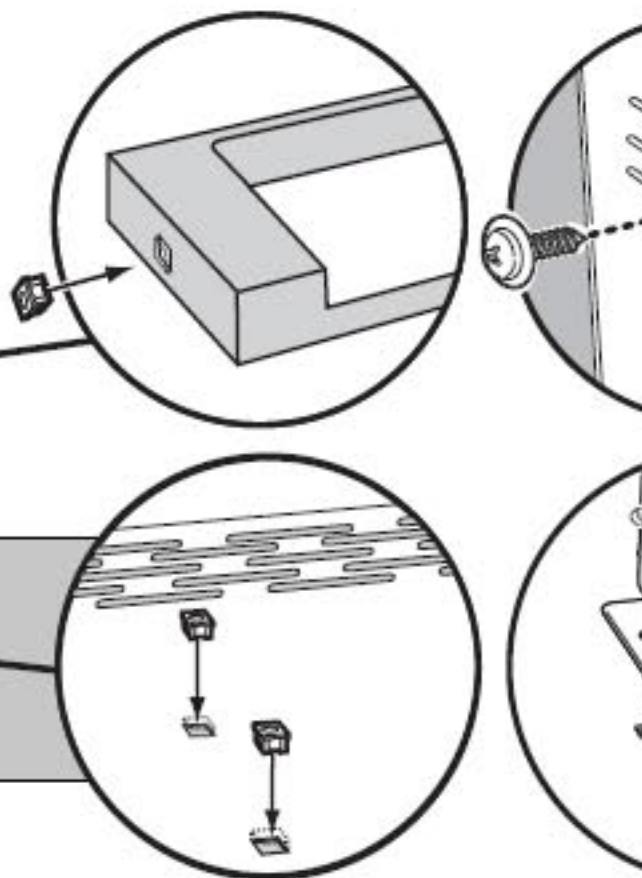
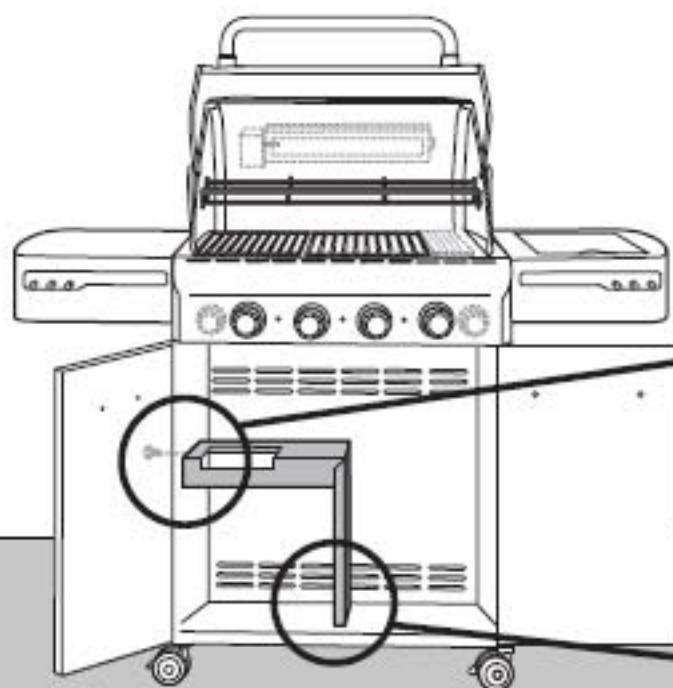

6

3-  3- 

7

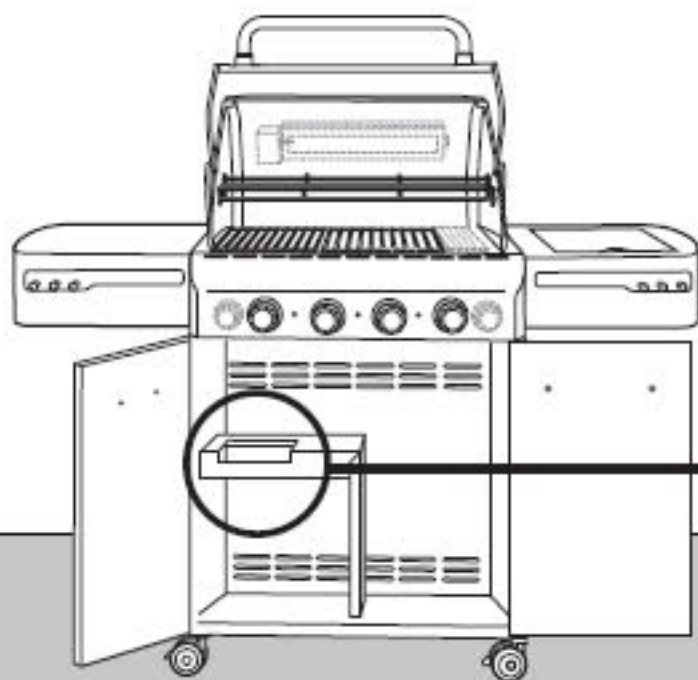

8

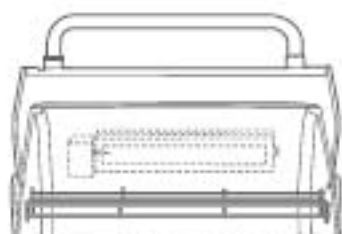

9

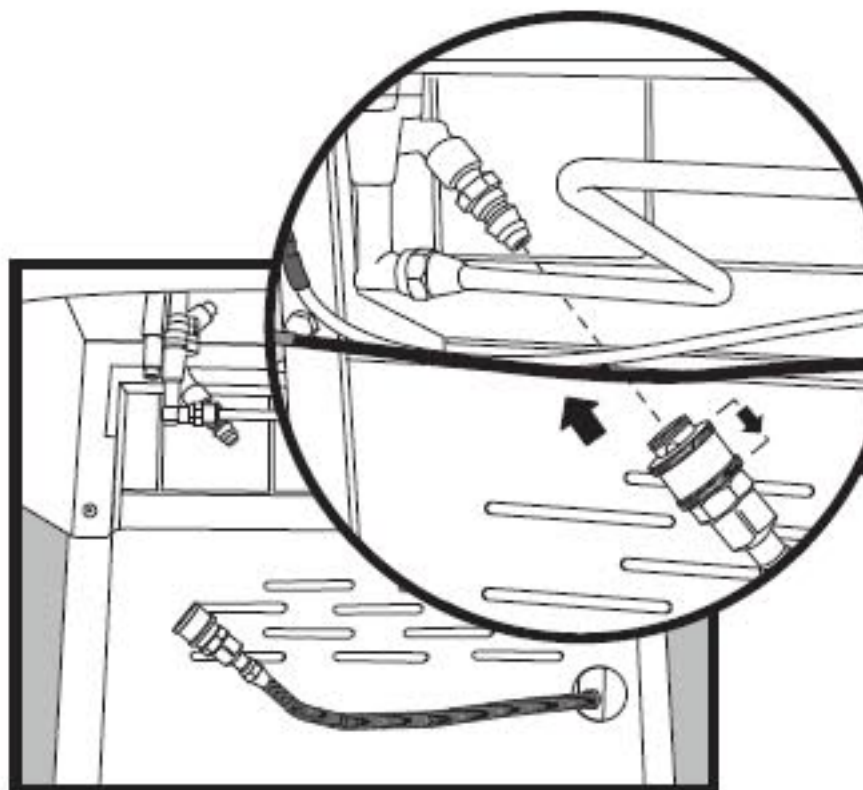
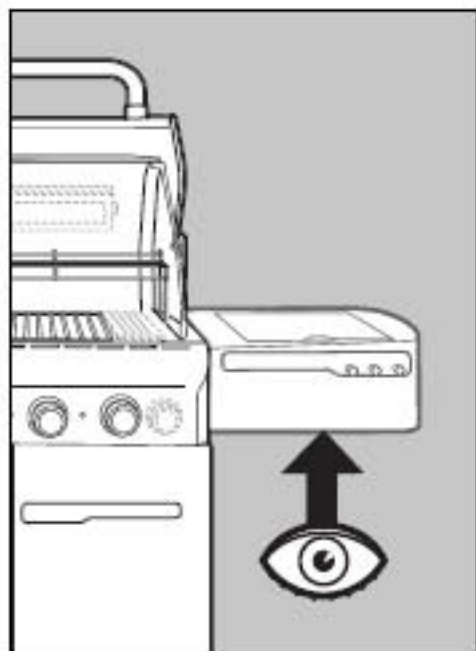

10

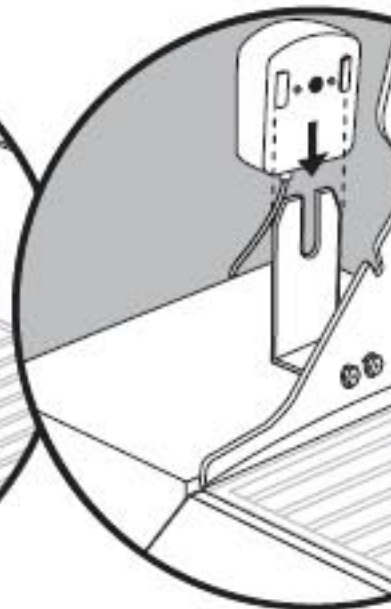
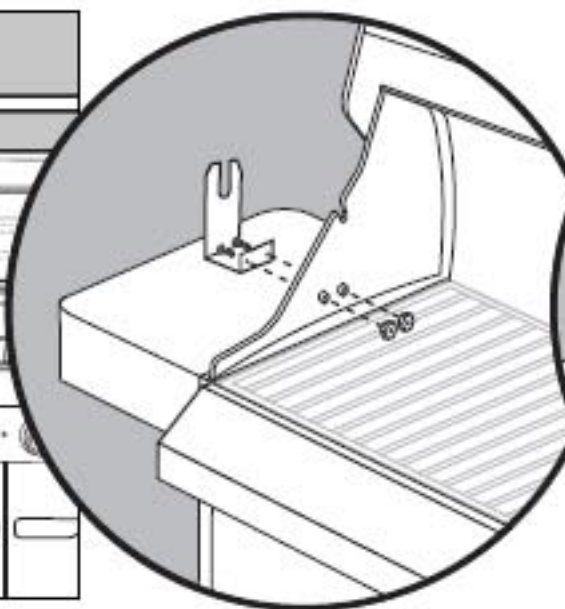
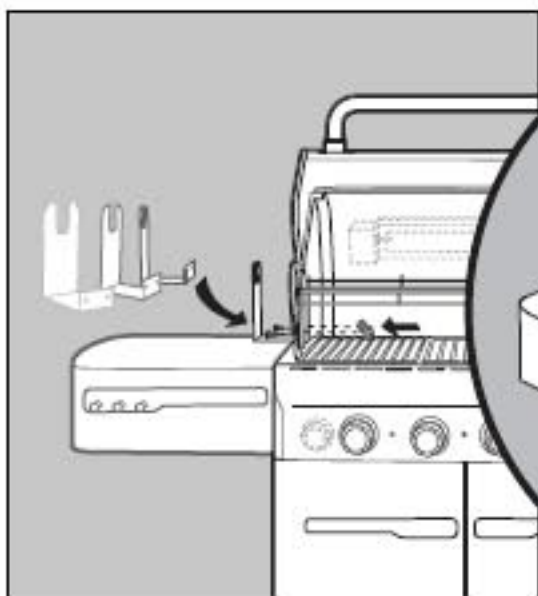

11

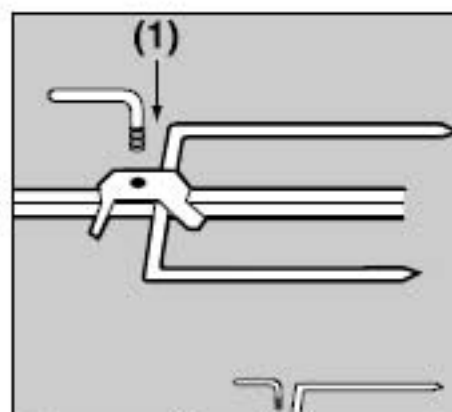
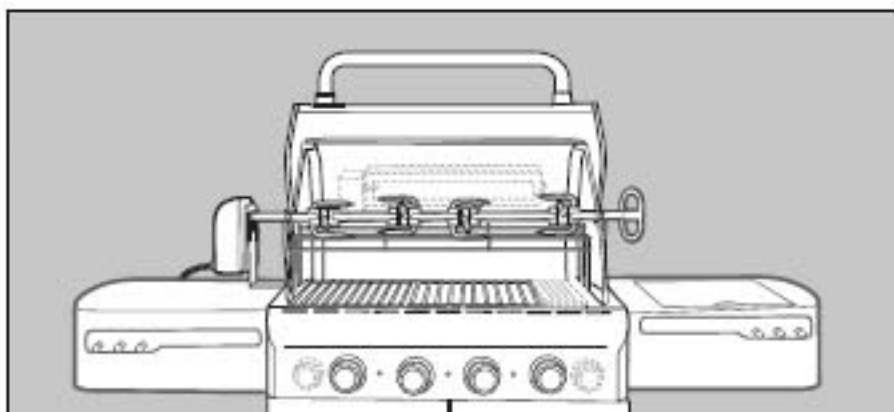

12

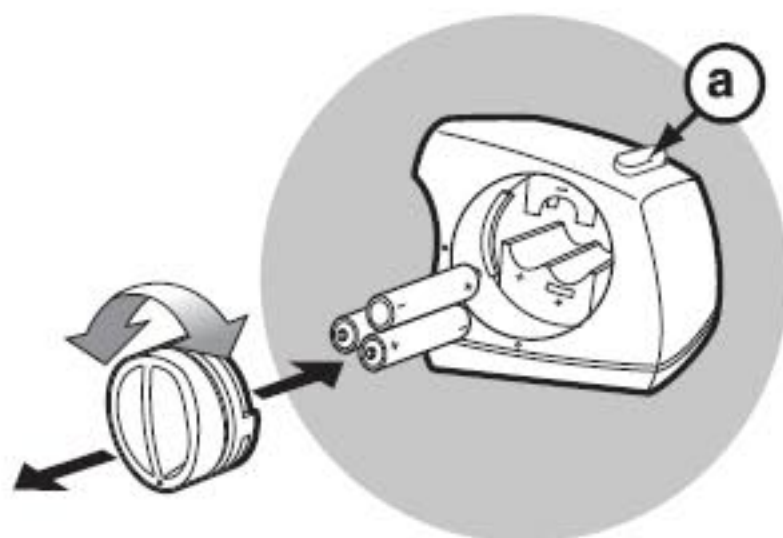

The Weber Grill Out™ Handle Light has a "Tilt Sensor": button (a) activates or deactivates the "Tilt Sensor." For pressing power button (a).

La Lámpara de Asa Weber Grill Out™ tiene un "sensor de inclinación" / tapa cerrada - APAGADA. El botón de encendido (a) activa o desactiva el sensor. Para uso durante el día, desactive el sensor pulsando el botón (a).

La Lampe de poignée Weber Grill Out™ est pourvu d'un "capteur de tilt" / Couvercle fermé - ARRET (OFF). Le bouton d'alimentation "Détecteur Tilt." Pour une utilisation pendant la journée, appuyez sur le bouton d'alimentation électrique (a).

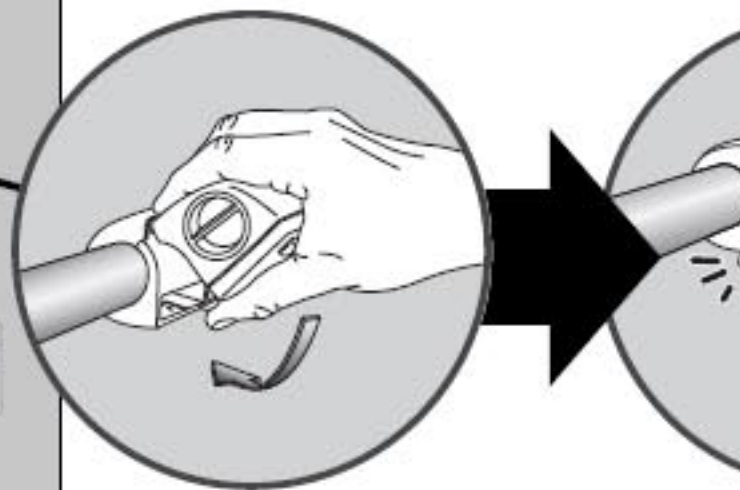
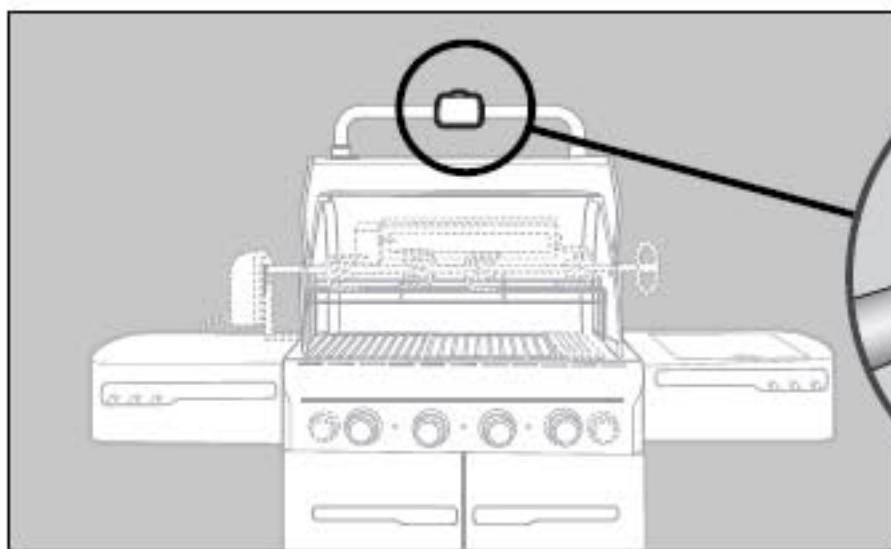
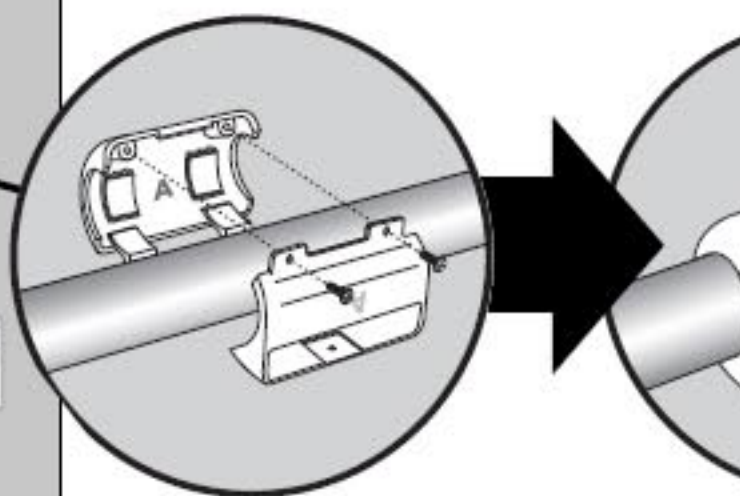
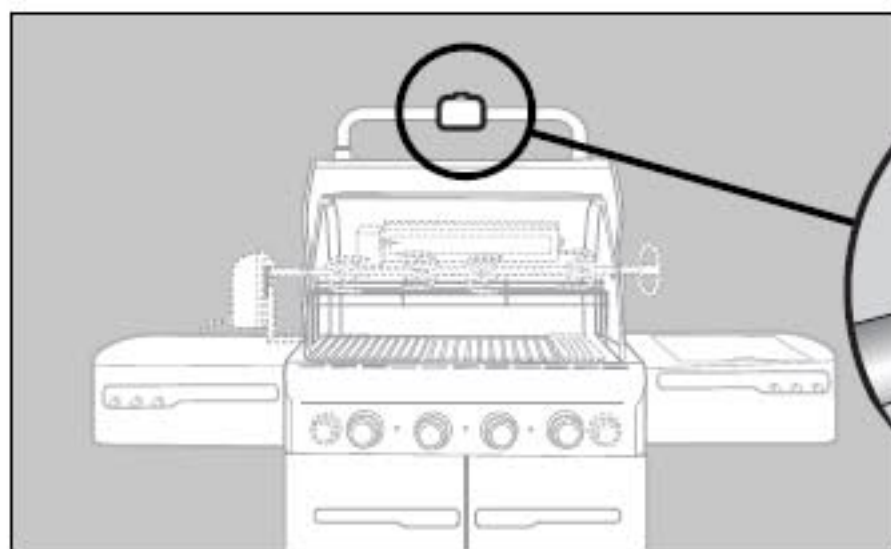

# GENERAL INSTRUCTIONS

Your Weber® gas barbecue is a portable outdoor cooking appliance. With the Weber® gas barbecue you can grill, barbecue, roast and bake with results that are difficult to duplicate with indoor kitchen appliances. The closed lid and Flavorizer® Bars produce that "outdoor" flavor in the food.

The Weber® gas barbecue is portable so you can easily change its location in your yard or on your patio. Portability means you can take your Weber® gas barbecue with, if you move.

Liquid Propane (LP) gas supply is easy to use and gives you more cooking control than charcoal fuel.

- These instructions will give you the minimum requirements for assembling your Weber® gas barbecue. Please read the instructions carefully before using your Weber® gas barbecue. Improper assembly can be dangerous.
- Not for use by children.
- If there are local codes that apply to portable gas grills, you will have to conform to them. Installation must conform with local codes or, in the absence of local codes, with either the National Fuel Gas Code, ANSI Z223.1/NFPA 54, Natural Gas and Propane Installation Code, CSA B149.1, or Propane Storage and Handling Code, B149.2, or the Standard for Recreational Vehicles, ANSI A 119.2/NFPA 1192, and CSA Z240 RV Series, Recreational Vehicle Code, as applicable.
- The pressure regulator supplied with the Weber® gas barbecue must be used. This regulator is set for 11 inches of water column (pressure).
- This Weber® gas barbecue is designed for use with liquid propane (LP) gas only. Do not use with natural (piped in city) gas. The valves, orifices, hose and regulator are for LP gas only.
- Do not use with charcoal fuel.
- Check that the area under the control panel and the bottom tray are free from debris that might obstruct the flow of combustion or ventilation air.
- The areas around the LP cylinder must be free and clear from debris.
- Replacement pressure regulators and hose assemblies must be those specified by Weber-Stephen Products Co.

## FOR INSTALLATION IN CANADA

These instructions, while generally acceptable, do not necessarily comply with the Canadian Installation codes, particularly with piping above and below ground. In Canada the installation of this appliance must comply with local codes and/or Standard CSA-B149.2 (Propane Storage and Handling Code).

## OPERATING

- ⚠ **WARNING:** Only use this barbecue outdoors in a well-ventilated area. Do not use in a garage, building, breezeway or any other enclosed area.
- ⚠ **WARNING:** Keep ventilation openings for cylinder enclosure free and clear from debris.

## GRILLING METHODS

*Note: If grill loses heat while cooking refer to the troubleshooting section of this manual.*

- ⚠ **WARNING:** Do not move the Weber® gas barbecue when operating or while barbecue is hot.

You can adjust the individual main burners as desired. The control settings are **START/ HI, MEDIUM, LOW, or OFF.**

*Note: The temperature inside your cooking box for the first few uses, while surfaces are still very reflective, may be hotter than those shown in your cookbook. Cooking conditions, such as wind and weather, may require the adjustment of the burner*

## STORAGE AND/OR NONUSE

- The gas must be turned off at the LP cylinder if the barbecue is not in use.
- When the Weber® gas barbecue is not in use, it must be DISCONNECTED and the LP cylinder must be stored outdoors in a well-ventilated area, away from children. Disconnected LP cylinder must not be stored in other enclosed area.
- When the LP cylinder is not disconnected, the appliance and LP tank must be kept outdoors.
- The Weber® gas barbecue should be cleaned before using. (See Section: "Maintenance/Annual Cleaning").
- Check that the areas under the control panel and the bottom tray are free from debris that might obstruct the flow of combustion or ventilation air.
- The Spider /Insect Screens should be removed before using. (See Section: "Maintenance/Annual Cleaning").

⚠ **WARNING:** Your Weber® gas barbecue must be stored under overhead combustibles.

⚠ **WARNING:** Your Weber® gas barbecue must be installed in or on recreation vehicles.

⚠ **WARNING:** Do not use the barbecue in the presence of combustible materials to the rear.

⚠ **WARNING:** The entire cooking area must not leave unattended.

⚠ **WARNING:** Keep any electrical supply hose away from any electrical components.

⚠ **WARNING:** Keep the cooking area free of grease and liquids such as gasoline and oil.

⚠ **WARNING:** Never store any flammable liquids near the Weber® gas barbecue.

⚠ **WARNING:** The LP cylinder must be with a listed OPD (Overhead Protection Device) a QCC1 or Type 1 (CGA810) cylinder connection must be used for the connection.

## CLEANING

⚠ **WARNING:** Turn your Weber® gas barbecue off to cool before cleaning.

⚠ **CAUTION:** Do not clean your grill grates in a self-cleaning oven.

For availability of replacement cooking grates, contact your Customer Service Representative in your area or visit our website. Log onto [www.weber.com](http://www.weber.com)

Outside surfaces - Use a warm soapy water solution.

**Slide out Bottom tray** - Remove excess grease, then wash with warm soapy water, then rinse.

**Flavorizer® bars and Cooking grates** - Clean with a suitable brass bristle brush. As needed, remove from grill and wash with warm soapy water, then rinse with water.

**Catch pan** - Disposable foil trays are available, or you can line the catch pan with aluminum foil. To clean the catch pan, wash with warm soapy water, then rinse.

**Thermometer** - Wipe with warm soapy water; clean with plastic scrub ball.

**Inside cooking module** - Brush any debris off of burner tubes. **DO NOT ENLARGE BURNER PORTS (OPENINGS)**. Wash inside of cooking box with warm soapy water and a water rinse.

**Inside Lid** - While lid is warm, wipe inside with paper towel to prevent grease build-up. Flaking built-up grease resembles paint flakes.

**Stainless steel surfaces** - Wash with a soft cloth and a soap and water solution. Be careful to scrub with the grain direction of the stainless steel.

**Do not use cleaners that contain acid, cleaning.**

**Preserve Your Stainless Steel** - Your grill may be made from stainless steel. To keep it in good condition is a simple matter. Clean it with soap and water. To remove stubborn particles, the use of a non-metallic scrubber is recommended.

**⚠ IMPORTANT: Do not use a wire brush on the stainless steel surfaces to avoid scratches.**

**⚠ IMPORTANT: When cleaning stainless steel, always clean in the direction of the grain.**

## GAS INSTRUCTIONS

### IMPORTANT LP CYLINDER INFORMATION

Failure to follow these DANGER statements exactly may result in a fire causing death or serious injury.

#### ⚠ DANGER

- ⚠ NEVER store a spare LP Cylinder under or near this barbecue.
- ⚠ NEVER fill the tank beyond 80% full.

Your Weber® gas grill is equipped for a cylinder supply system designed for vapor withdrawal.

**⚠ WARNING: Only use this grill outdoors in a well-ventilated area. Do not use in a garage, building, breezeway or any other enclosed area.**

The proper filling methods for the filling of LP cylinders are described in NFPA 58. Please make sure you know the correct weight or volume. Ask your filling station for the correct LP cylinder before attempting to fill.

### LEAK CHECK PREPARATION

#### CHECK THAT ALL BURNER VALVES ARE OFF

Valves are shipped in the "OFF" position, turned off. Check by pushing down and turning the knob clockwise. If they do not turn, they are off. Proceed to the next step. If they do turn, then they are off. Proceed to the next step.

### CONNECTING THE LIQUID PROPANE CYLINDER

All Weber® liquid propane gas grill regulators are equipped with a UL-Listed tank connection as per the latest edition of ANSI Z21.58. This will require a liquid propane tank that is similarly equipped with a Type 1 connection in the tank valve. This Type 1 coupling allows you to make a fast and totally safe hookup between your gas grill and your liquid propane tank. It eliminates the chance of leaks due to a POL fitting that is not properly tightened. Gas will not flow from the tank unless the Type 1 coupling is fully engaged into the coupling.

**⚠ WARNING: Make sure that the LP cylinder valve is closed. Close by turning valve clockwise.**

#### ⚠ DANGER

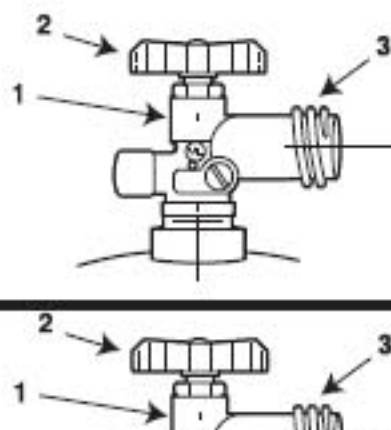

# GAS INSTRUCTIONS

## TO CONNECT THE HOSE TO THE CYLINDER:

- 1) Locate hose retention clip (a) on regulator hose. Secure into slot (b) on underside of tank scale.

**⚠ WARNING:** The hose must be secured to the tank scale with the Hose Retention Clip. Failure to do so could cause damage to the hose resulting in a fire or explosion which can cause serious bodily injury or death, and damage to property.

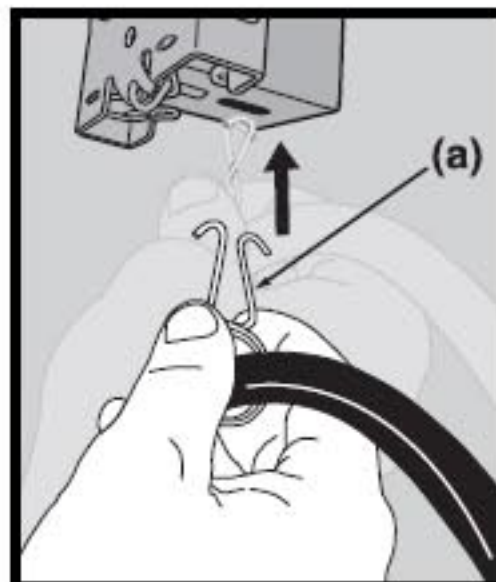

Some LP tanks have differing top collar assemblies. (The top collar is the metal protective ring around the valve.) One series of tanks mount with the valve facing front (a). The other tanks mount with the valve facing away from the fuel scale (b). Weber recommends the use of cylinder manufacturer's Manchester and Worthington, with a 47.6 lb water capacity. Other cylinders may be acceptable for use with the appliance provided they are compatible with the appliance retention means (see illustrations).

The LP cylinder is installed inside the base cabinet, on the tank scale (right side).

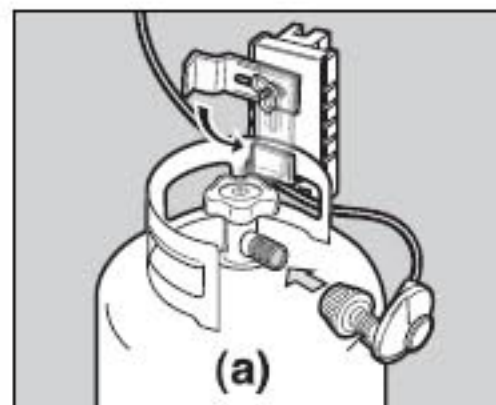

- 2) Open base cabinet doors.
- 3) Turn the LP cylinder so the opening of the valve is either to the front, side or rear of the Weber® gas barbecue. Lift and hook the cylinder onto the fuel gauge.
- 4) Lift tank up into position on the tank scale.
- 5) Loosen the cylinder lock wing nut. Swing the cylinder lock down. Tighten the wing nut.

## TO CONNECT THE HOSE TO THE CYLINDER:

- 6) Remove the plastic dust cover from the valve.
- 7) Screw the regulator coupling onto the tank valve, clockwise, or to the right. Hand-tighten only.

*Note: This connection tightens clockwise and will not allow gas to flow unless the connection is tight. The connection requires tightening by hand only.*

**⚠ WARNING:** Do not use a wrench to tighten the connection. Using a wrench could damage the regulator coupling and could cause a leak.

You will need: LP cylinder, a soap and water solution and a rag or brush to apply it.

- 8) Mix soap and water.
- 9) Turn on the cylinder valve.
- 10) Check for leaks by wetting the fitting with the soap and water solution and watching for bubbles. If bubbles form, or if a bubble grows, there is a leak.

If there is a leak, turn off the gas and tighten the fitting. Turn the gas back on and recheck with the soap and water solution.

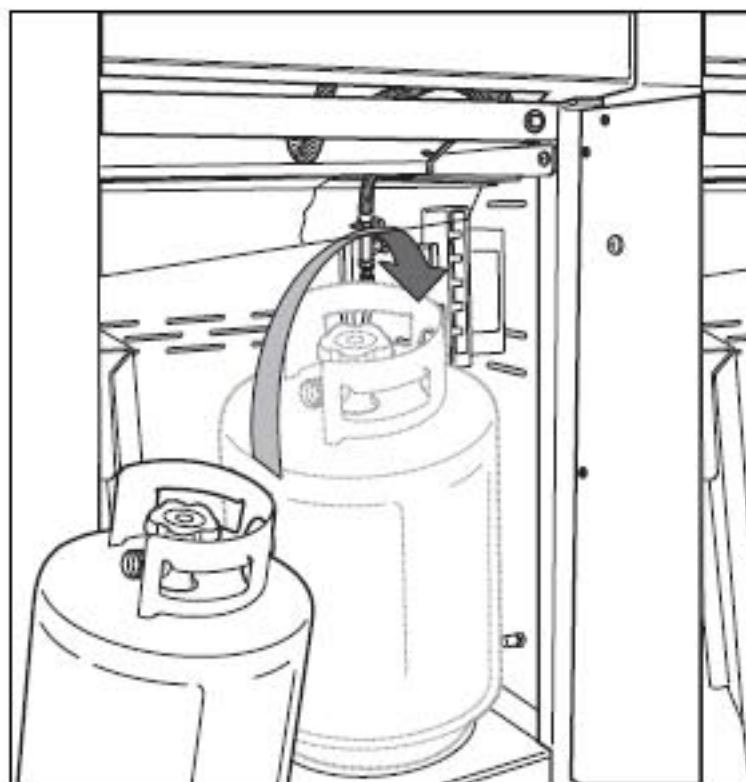

## CHECK FOR GAS LEAKS

**⚠ WARNING:** The gas connections of your Summit® gas grill have been factory tested. We do however recommend that you leak check all gas connections before operating your Summit® gas grill.

## REMOVE CONTROL PANEL

Tool required: Phillips Screwdriver.

- 1) Remove the burner control knobs.
- 2) Remove the two screws that secure the control panel to the frame.
- 3) Remove the control panel. Tilt panel forward and lift up and away from grill.

Completely remove the control panel (3) from the cooking box assembly exposing the valves, burners, igniter, and manifold.

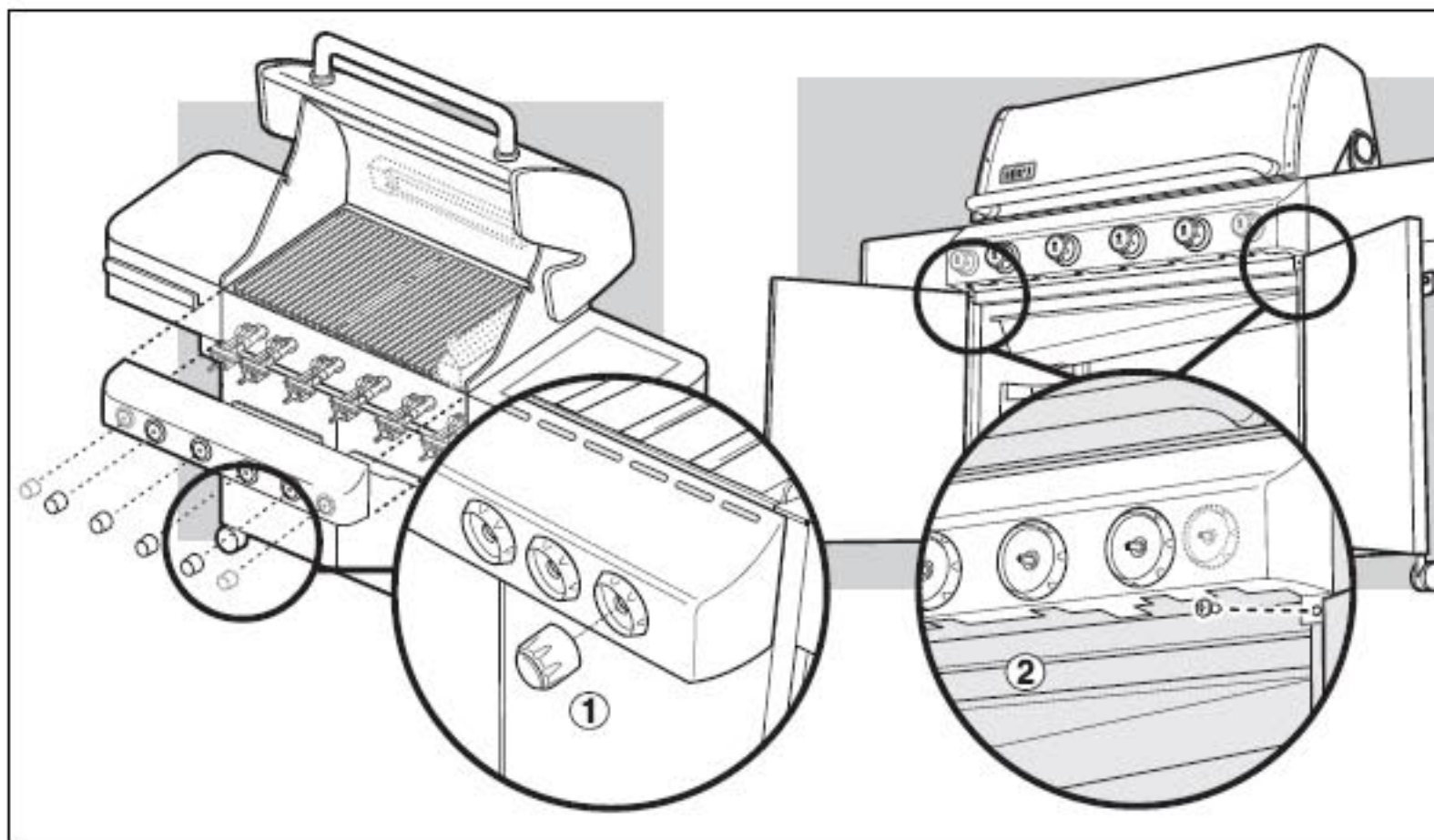
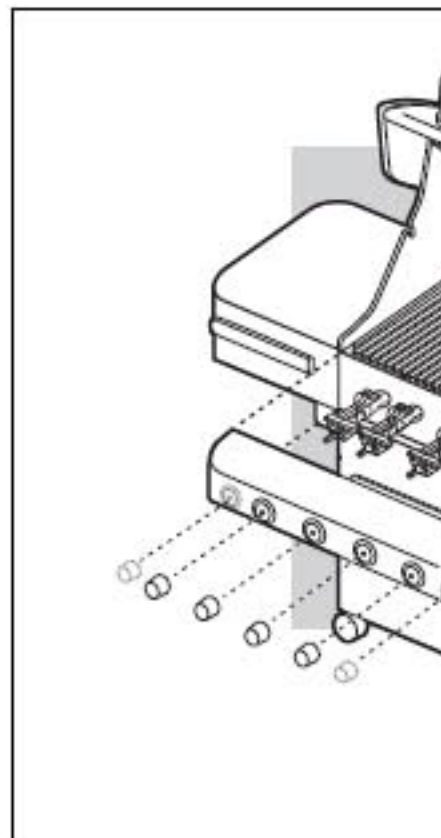

## CHECK FOR GAS LEAKS

**⚠ DANGER**

Do not use an open flame to check for gas leaks. Be sure

**⚠ WARNING:** Perform these steps only if the barbecue was dealer or store

You will need: a soap and water solution,

# GAS INSTRUCTIONS

## CHECK:

- 1) Bulkhead and gas supply hose connection.
- 2) Main gas line to manifold connections.

**⚠ WARNING:** If there is a leak at connection (1, or 2), retighten the fitting with a wrench and recheck for leaks with soap and water solution.

If a leak persists after re-tightening the fitting, turn off the gas. **DO NOT OPERATE THE GRILL.** Contact the Customer Service Representative in your area using the contact information on our web site. Log onto [www.weber.com](http://www.weber.com)®.

- 3) Side burner hose to bulkhead connection.
- 4) Side burner hose to Quick disconnect connection, side burner valve and orifice connections.
- 5) Regulator to cylinder connection.
- 6) Hose to regulator connection.
- 7) Valves to manifold connections.

**⚠ WARNING:** If there is a leak at connections (3, 4, 5, 6 or 7), turn off the gas. **DO NOT OPERATE THE GRILL.** Contact the Customer Service Representative in your area using the contact information on our web site. Log onto [www.weber.com](http://www.weber.com)®.

When leak checks are complete, turn gas supply off at the source and rinse connections with water.

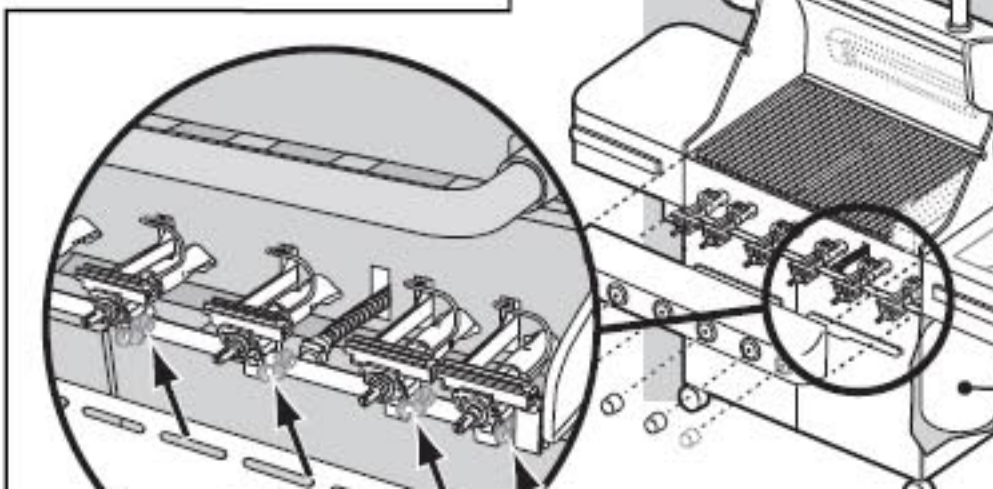
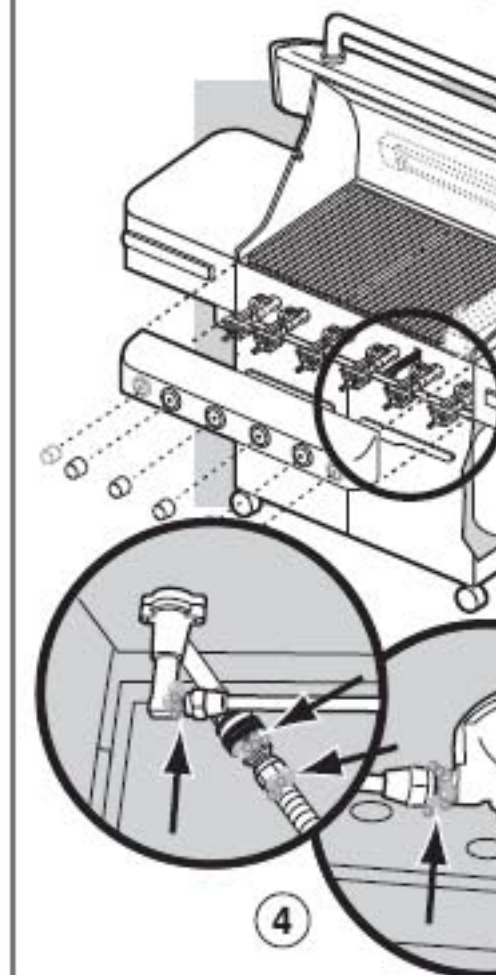
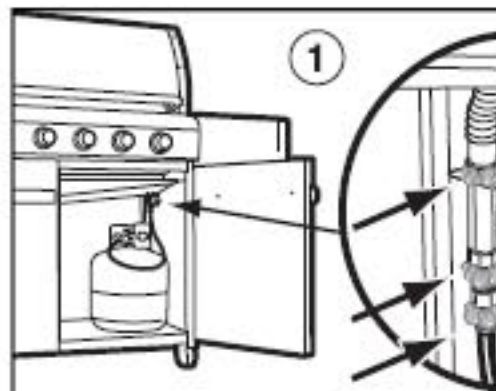

**CHECK:**

- 1) Main gas line to manifold connection.
- 2) Rotisserie (I.R. Burner) gas line connection.
- 3) Bulkhead and gas supply hose connection.

**⚠ WARNING:** If there is a leak at connection (1, 2, or 3), retighten the fitting with a wrench and recheck for leaks with soap and water solution.

If a leak persists after re-tightening the fitting, turn off the gas. **DO NOT OPERATE THE GRILL.** Contact the Customer Service Representative in your area using the contact information on our web site. Log onto [www.weber.com](http://www.weber.com)®.

- 4) Side burner hose to bulkhead connection.
- 5) Side burner hose to quick disconnect connection, side burner valve and orifice connections.
- 6) Hose to regulator connection.
- 7) Regulator to cylinder connection.
- 8) Valves to manifold connections.

**⚠ WARNING:** If there is a leak at connections (4, 5, 6, 7, or 8), turn off the gas. **DO NOT OPERATE THE GRILL.** Contact the Customer Service Representative in your area using the contact information on our web site. Log onto [www.weber.com](http://www.weber.com)®.

When leak checks are complete, turn gas supply off at the source and rinse connections with water.

**REINSTALL CONTROL PANEL**

Parts required: control panel, screws and burner control knobs.

Hook the top edge of the control panel onto the control panel brackets on either side of the front of the cooking box.

Line up screws with screw holes on both the control panel bracket and the frame.

Tighten screws.

Place corresponding control knobs onto the valve stems.

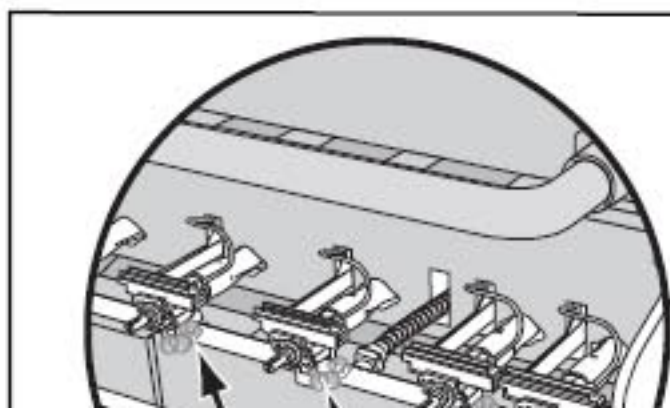
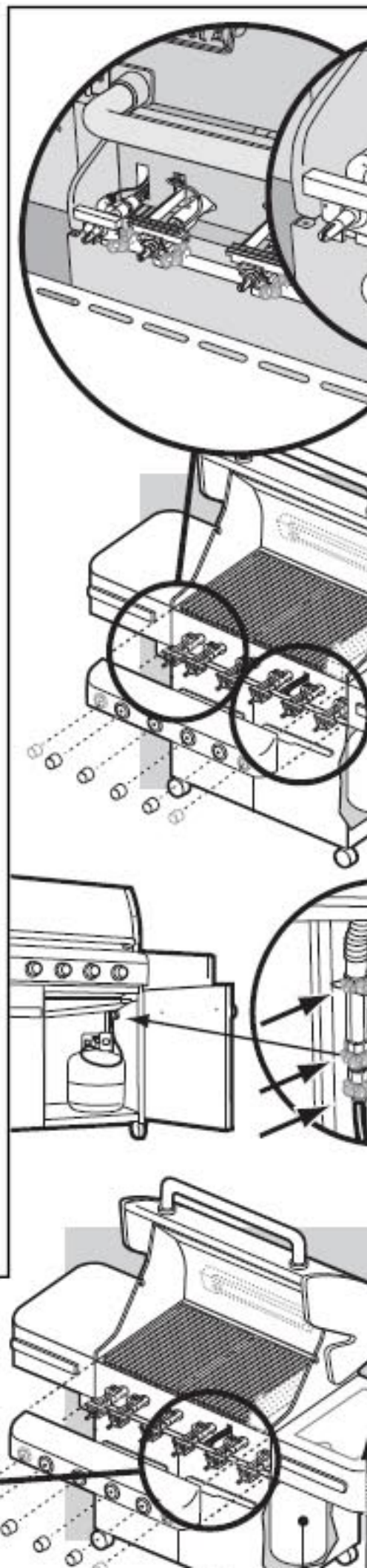

# GAS INSTRUCTIONS

## REFILLING THE LIQUID PROPANE CYLINDER

We recommend that you refill the LP cylinder before it is completely empty.

Removal of the LP cylinder

- 1) Close cylinder valve (turn clockwise).
- 2) Unscrew regulator coupling by turning counterclockwise, by hand only.
- 3) Loosen cylinder lock wing nut and turn cylinder lock up out of the way.
- 4) Lift cylinder off.

To fill, take the LP cylinder to a gas propane dealer, or look up "gas-propane" in the phone book for other sources of LP gas.

**⚠ WARNING: We recommend that your LP cylinder be filled at an authorized LP gas dealer, by a qualified attendant, who fills the cylinder by weight. IMPROPER FILLING IS DANGEROUS.**

**⚠ CAUTION: Place dust cap on cylinder valve outlet whenever the cylinder is not in use. Only install the type of dust cap on the cylinder valve outlet that is provided with the cylinder valve. Other types of caps or plugs may result in leakage of propane.**

## CHECKING THE FUEL LEVEL IN YOUR TANK

Check the fuel level by viewing the color indicator level line on the side of the tank scale.

- 1) Empty
- 2) Medium
- 3) Full

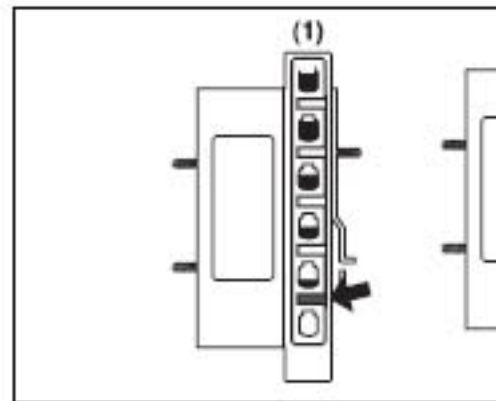
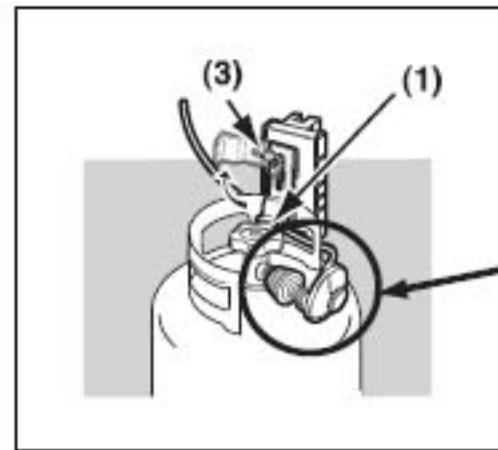

## SAFE HANDLING TIPS FOR LIQUID PROPANE GAS CYLINDERS

- Liquid Propane (LP) gas is a petroleum product as are gasoline and natural gas. LP gas is a gas at regular temperatures and pressures. Under moderate pressure, inside a cylinder, LP gas is a liquid. As the pressure is released, the liquid readily vaporizes and becomes gas.
- LP gas has an odor similar to natural gas. You should be aware of this odor.
- LP gas is heavier than air. Leaking LP gas may collect in low areas and prevent dispersion.
- To fill, take the LP cylinder to a gas propane dealer, or look up "gas-propane" in the phone book for other sources of LP gas.

**⚠ WARNING: We recommend that your LP cylinder be filled at an authorized LP gas dealer, by a qualified attendant, who fills the tank by weight. IMPROPER FILLING IS DANGEROUS.**

- Air must be removed from a new LP cylinder before the initial filling. Your LP dealer is equipped to do this.
- The LP cylinder must be installed, transported and stored in an upright position. LP cylinders should not be dropped or handled roughly.
- Never store or transport the LP cylinder where temperatures can reach 125° F (too hot to hold by hand - for example: do not leave the LP cylinder in a car on a hot day).

*Note: A refill will last about 18-20 hours of cooking time at normal use. The fuel scale will indicate the propane supply so you can refill before running out. You do not have to run out before you refill.*

- Treat "empty" LP cylinders with the same care as when full. Even when the LP tank is empty of liquid there still may be gas pressure in the cylinder. **Always close the cylinder valve before disconnecting.**

**⚠ CAUTION: Place dust cap on cylinder valve outlet whenever the cylinder is not in use. Only install the type of dust cap on the cylinder valve outlet that is provided with the cylinder**

**⚠ WARNING: Replacement LP connection supplied with the**

### LIQUID PROPANE CYLINDER

- Check to be sure cylinders have a life span of at least 5 years within five years. Your LP gas supplier can provide this information.
- All LP tank supply systems must meet the requirements of the LP cylinder.
- The LP cylinder must be a 20-lb. size (14 inches in diameter).
- The cylinder must be constructed to meet the requirements of the Specifications for LP - Gas Cylinder (D.O.T.) or the National Standard of Spheres and Tubes or Transportation applicable.

### IN CANADA

### LIQUID PROPANE CYLINDER RECOMMENDATIONS

*Note: Your retailer can help you match a*

- The LP cylinder must be constructed to meet the requirements of the specifications for LP gas cylinders,

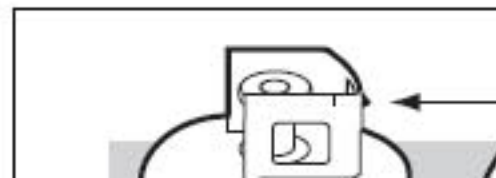

## GRILLING METHODS

*Note: If grill loses heat while cooking refer to the troubleshooting section of this manual.*

You can adjust the individual burners as desired. The control settings are **START/HI**, **MEDIUM**, **LOW**, or **OFF**.

If burners go out during cooking, turn off all burners and wait 5 minutes before relighting.

**⚠ WARNING: Check the bottom tray and catch pan for grease build-up before each use. Remove excess grease to avoid a grease fire in the bottom tray.**

## PREHEATING

Preheating the grill before grilling is important. Light your Summit® gas grill according to the instructions in this Owner's Manual. Turn all of the main burners to **Start/Hi**, close the lid, and preheat grill with the lid down until grill thermometer reaches 550°F (260°-288°C). This is the recommended broiling temperature. This will take approximately 10 to 15 minutes, depending on outside temperatures.

## COVERED COOKING

All grilling is done with the lid down to provide uniform, evenly circulated heat. With the lid closed, the Summit® gas grill cooks much like a convection oven. The thermometer in the lid indicates the cooking temperature inside the grill. All preheating and grilling is done with the lid down. No peeking — heat is lost every time you lift the lid.

The most important thing to know about grilling is which cooking method to use for a specific food, Direct or Indirect. The difference is simple: place the food directly over the fire, or arrange the fire on either side of it. Using the right method is the shortest route to great results—and the best way to ensure doneness safety.

## DIRECT COOKING

The Direct Method, similar to broiling, means the food is cooked directly over the heat source. For even cooking, food should be turned once halfway through the grilling time. Use the Direct method for foods that take less than 25 minutes to cook: steaks, chops, kabobs, sausages, vegetables, and more.

Direct cooking is also necessary to sear meats. Searing creates that wonderful crisp, caramelized texture where the food hits the grate. It also adds great color and flavor to the entire surface. Steaks, chops, chicken breasts, and larger cuts of meat all benefit from searing.

To sear meats, place them over Direct High heat for 2 to 5 minutes per side. Smaller pieces require less searing time. Usually after searing you finish cooking the food at a lower temperature. You can finish cooking fast-cooking foods by the Direct method; use the Indirect method for longer-cooking foods.

To set up your gas grill for Direct cooking, preheat the grill with all burners on "HI". Place food on the cooking grate, and then adjust all burners to the temperature noted in the recipe. Close the lid of the grill and lift it only to turn food or to test for doneness at the end of the recommended cooking time.

## INDIRECT COOKING

The Indirect Method is similar to roasting, but with the added benefits of that grilled texture, flavor, and appearance you can't get from an oven. To set up for Indirect cooking, gas burners are lit on either side of the food but not directly beneath it. Heat rises, reflects off the lid and inside surfaces of the grill, and circulates to slowly cook the food evenly on all sides, much like a convection oven, so there's no need to turn the food.

Use the Indirect method for foods that require 25 minutes or more of grilling time or that are so delicate that direct exposure to the flame would dry them out or scorch them.

ARRÊTÉ  
OFF  
APAGADO



D.

OFF

## FLAVORIZER® SYSTEM

When meat juices drip from the food onto the grill, they create smoke that gives foods an irresistible flavor. The unique design of the burners, Flavorizer® System, virtually eliminates uncontrolled flare-ups. Because of the special design of the Flavorizer System, heat is directed through the funnel-shaped bottom

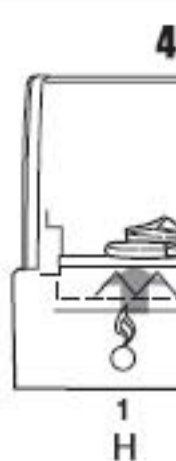

**Direct Method**  
*Food is placed on  
grates directly over*

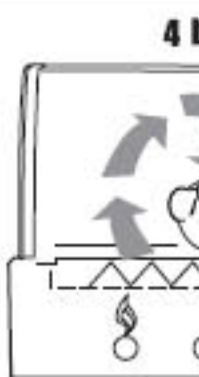

# OPERATING INSTRUCTIONS

## GRILLING TIPS & HELPFUL HINTS

- Always preheat the grill before cooking. Set all burners on "HI" heat and close lid; heat for 10 minutes, or until thermometer registers 500°-550°F (260°-288°C).
- Sear meats and cook with the lid down for perfectly grilled food every time.
- Grilling times in recipes are based on 70°F (20°C) weather and little or no wind. Allow more cooking time on cold or windy days, or at higher altitudes. Allow less cooking time in extremely hot weather.
- Grilling times can vary because of the weather, or the amount, size and shape of the food being grilled.
- The temperature of your Summit® gas grill may run hotter than normal for the first few uses.
- Grilling conditions may require the adjustment of the burner controls to attain the correct cooking temperatures.
- In general, large pieces of meat will require more cooking time per pound than small pieces of meat. Foods on a crowded cooking grate will require more cooking time than just a few foods. Foods grilled in containers, such as baked beans, will require more time if grilled in a deep casserole rather than a shallow baking pan.
- Trim excess fat from steaks, chops and roasts, leaving no more than a scant ¼ inch (6.4mm) of fat. Less fat makes cleanup easier, and is a virtual guarantee against unwanted flare-ups.

- Foods placed on the cooking grate may move to a less hot area.
- Use tongs rather than a fork for turning meats. Use two spatulas for handling delicate foods.
- If an unwanted flare-up should occur, move the food to another area of the cooking grate. Allow the flare-up to subside, relight the grill. NEVER USE A MATCH TO LIGHT A GAS GRILL.
- Some foods, such as a casserole or a large roast, are not good for grilling. Disposable foil pans are not recommended. Ovenproof handles can also be used.
- Always be sure the bottom tray and burner covers are free of debris.
- Do not line the funnel-shaped bottom of the grill with foil to prevent grease from flowing into the grease catch pan.
- Using a timer will help to alert you when the food is done."

## SNAP IGNITION OPERATION

### ⚠ Always open the lid before igniting the burners

Each control knob has its own igniter electrode built in. To create a spark you must push the control knob in (A) and turn to "START/High" (B).

This action will generate gas flow and a spark to the burner lighting tube (C). You will hear a "snap" from the igniter. You will also see a 3" - 5" orange flame coming from the burner lighting tube at the left side of the burner (D).

Continue to hold the burner control knob in for two seconds after the "snap". This will allow gas to flow completely down the burner tube (E) and insure ignition.

Check that the burner is lit by looking through the cooking grates. You should see a flame. If burner does not light on first try, push control knob in and turn to OFF. Repeat lighting procedure a second time.

⚠ **WARNING:** If the burner still does not light, turn the burner control knob to "OFF" and wait 5 minutes to let the gas clear before you try again or try to light with a match.

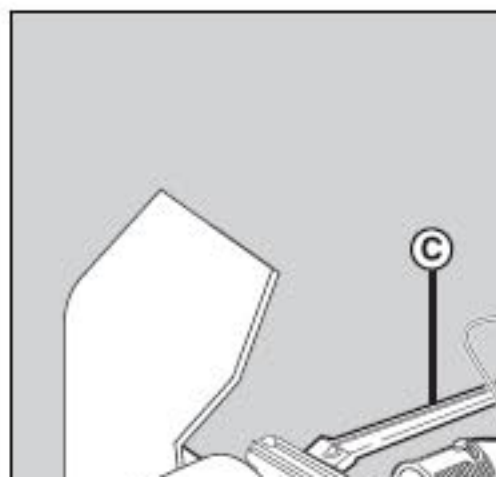
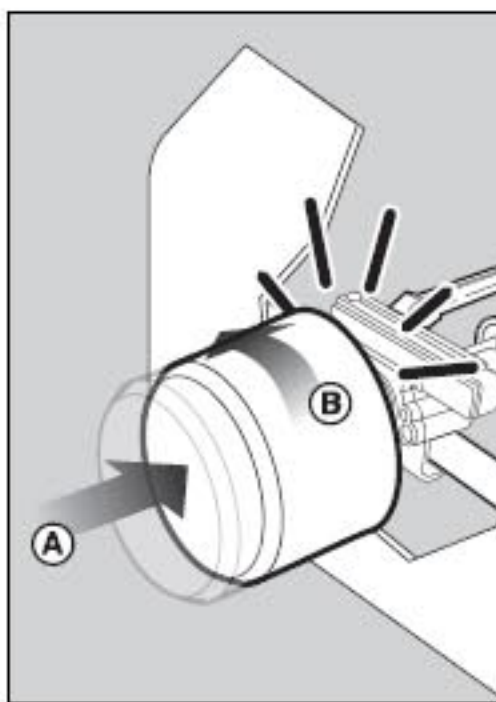

## LIGHTING

Summary lighting instructions are inside the left hand cabinet door.

**⚠ DANGER**

Failure to open the lid while igniting the barbecue's burners, or not waiting 5 minutes to allow the gas to clear if the barbecue does not light, may result in an explosive flame-up which can cause serious bodily injury or death.

## MAIN BURNER SNAP IGNITION

*Note: Each control knob snap igniter creates a spark from the igniter electrode to the burner lighting tube. You generate the energy for the spark by pushing in the control knob and turning to "START/HI". This will ignite each individual burner.*

**⚠ WARNING:** Check hose before each use of barbecue for nicks, cracking, abrasions or cuts. If the hose is found to be damaged in any way, do not use the barbecue. Replace using only Weber® authorized replacement hose. Contact the Customer Service Representative in your area using the contact information on our web site.

Log onto [www.weber.com](http://www.weber.com)®.

- 1) Open the lid.
- 2) Make sure all burner control knobs are turned off. (Push control knob in and turn clockwise to ensure that it is in the "OFF" position.)

**⚠ WARNING:** The burner control knobs must be in the "OFF" position before turning on the liquid propane cylinder tank valve. If they are not in the "OFF" position, when you turn on the LP cylinder valve, the "excess gas flow control" feature will activate, limiting the flow of gas from the LP cylinder. If this should occur, turn off the LP cylinder valve and burner control knobs. Then start over.

**⚠ DANGER**

When the "excess gas flow control" feature is activated, a small amount of gas is still flowing to the burners. After turning off the cylinder and burner control knobs, wait at least 5 minutes for the gas to clear before attempting to light the grill. Failure to do so may result in an explosive flare-up, which can cause serious bodily injury or death.

- 3) Turn the cylinder on by turning the cylinder valve counterclockwise.

**⚠ WARNING:** Do not lean over the open barbecue.

- 4) Push the control knob in and turn to "START/HI" until you hear the igniter snap - continue to hold control knob in for two seconds. This action will spark the igniter, the burner lighting tube and then main burner.
- 5) Check that the burner is lit by looking through the cooking grates. You should see a flame. If burner does not light on first try, push control knob in and turn to OFF. Repeat lighting procedure a second time.

**⚠ WARNING:** If the burner still does not light, turn the burner control knob to "OFF" and wait 5 minutes to let the gas clear before you try again or try to light with a match.

## MAIN BURNER LIGHTING

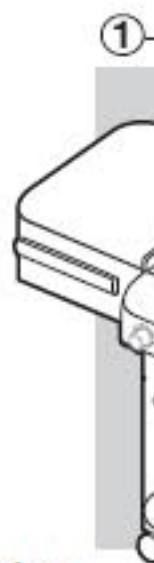

\*The grill illustrated may have slight differences than the model purchased.



## TO EXTINGUISH

Push in and turn each burner control knob off at the source.

# OPERATING INSTRUCTIONS

## MAIN BURNER MANUAL LIGHTING

### ⚠ DANGER

Failure to open the lid while igniting the barbecue's burners, or not waiting 5 minutes to allow the gas to clear if the barbecue does not light, may result in an explosive flame-up which can cause serious bodily injury or death.

- 1) Open the lid.
- 2) Make sure all burner control knobs are turned off. (Push each knob in and turn clockwise to ensure they are in the "OFF" position.)

**⚠ WARNING:** The burner control knobs must be in the "OFF" position before turning on the liquid propane cylinder valve. If they are not in the "OFF" position, when you turn on the LP cylinder valve, the "excess gas flow control" feature will activate, limiting the flow of gas from the LP cylinder. If this should occur, turn off the LP tank valve and burner control knobs. Then start over.

### ⚠ DANGER

When the "excess gas flow control" feature is activated, a small amount of gas is still flowing to the burners. After turning off the cylinder and burner control knobs, wait at least 5 minutes for the gas to clear before attempting to light the barbecue. Failure to do so may result in an explosive flame-up, which can cause serious bodily injury or death.

- 3) Turn the cylinder on by turning the cylinder valve counterclockwise.
- 4) Put match in the match holder and strike match.

**⚠ WARNING:** Do not lean over open barbecue.

- 5) Insert match holder and lit match down through cooking grates and Flavorizer® bars to ignite the selected burner.
- 6) Push the control knob in and turn to "START/HI".

**⚠ WARNING:** If the burner does not light, turn the burner control knob to "OFF" and wait 5 minutes to let the gas clear before you try again.

## MAIN BURNER MANUAL LIGHTING

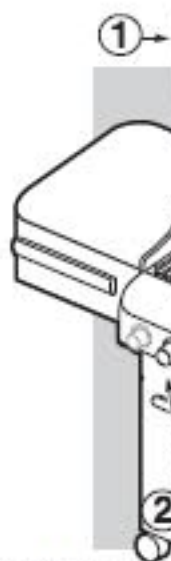

\*The grill illustrated may have slight differences than the model purchased.



## TO EXTINGUISH

Push in and turn each burner control knob off at the source.

## LIGHTING THE SIDE BURNER

### ⚠ DANGER

Failure to open the lid while igniting the side burner, or not waiting 5 minutes to allow the gas to clear if the side burner does not light, may result in an explosive flame-up which can cause serious bodily injury or death.

**⚠ WARNING:** Check hose before each use of barbecue for nicks, cracking, abrasions or cuts. If the hose is found to be damaged in any way, do not use the barbecue. Replace using only Weber® authorized replacement hose. Contact the Customer Service Representative in your area using the contact information on our web site. Log onto [www.weber.com](http://www.weber.com)®.

- 1) Open the side burner lid.

## SIDE BURNER LIGHTING



## MANUALLY LIGHTING THE SIDE BURNER

**⚠ DANGER**

Failure to open the lid while igniting the side burner, or not waiting 5 minutes to allow the gas to clear if the side burner does not light, may result in an explosive flare-up that can cause serious bodily injury or death.

- 1) Open the side burner lid.
- 2) Check that the side burner valve is turned off (Push control knob in and turn clockwise to ensure that it is in the "OFF" position), turn all burners not being used to the "OFF" position (push in and turn clockwise).
- 3) Turn the gas supply valve on.
- 4) Put match in a match holder and strike match.
- 5) Hold match holder and lit match by either side of the side burner.
- 6) Push down and turn the side burner control valve to "HI".

**⚠ CAUTION:** Side burner flame may be difficult to see on a bright sunny day.

**⚠ WARNING:** If the side burner does not light in five (5) seconds:

- a) Turn off the side burner control valve, main burners and gas supply at source.
- b) Wait 5 minutes to let the gas clear before you try again.

## MANUAL SIDE BURNER LIGHTING



## USING THE SMOKER

The smoker uses presoaked wood chips. For best results with faster cooking foods like steaks, burgers and chops, etc., we recommend using finer wood chips because they ignite and create smoke faster. For longer cooking foods such as roasts, chicken and turkeys, etc., we recommend using larger wood chunks because they ignite slowly and provide smoke for a longer period of time. As you gain experience in using your smoker, we encourage you to experiment with different combinations of wood chips and chunks to find the smoke flavor that best suits your taste.

## TO USE THE SMOKER

As a starting point, soak wood chips in water for at least 30 minutes before using. (Wet wood will produce more smoke flavor.) Place a handful of wood chips or a few larger chunks in the bottom of the smoker body (1). As you gain experience in smoking, increase or decrease the amount of wood to suit your taste.

*Note: Always grill with the lid closed to allow the smoke to fully penetrate the food.* Light the smoker burner by following the instructions for Lighting The Smoker Burner. After wood starts to smolder turn control knob to "LOW".

Smoke will start in approximately 10 minutes and last as long as 45 minutes. If you require more smoke flavor, refill the smoker with wood chips and /or chunks. Keep the lid of the grill closed while cooking.

*Note: After refilling smoker, smoke will take about 10 to 15 minutes to start again.* The smoker may be used to enhance meat, poultry and fish recipes. Cook with the lid down according to the times indicated in charts or recipes.

**E/S-450**

## CLEANING THE SMOKER

Before each use, empty the smoker of ash. *Note: Smoking will leave a "smoke" residue that cannot be removed and will not affect the "smoke" residue will accumulate on the*

**⚠ DANGER**

# OPERATING INSTRUCTIONS

## LIGHTING THE SMOKER BURNER

### ⚠ DANGER

Failure to open the lid while igniting the grill, or not waiting 5 minutes to allow the gas to clear if the grill does not light, may result in an explosive flare-up which can cause serious bodily injury or death.

## SMOKER BURNER SNAP IGNITION

*Note: The control knob snap igniter creates a spark from the igniter electrode to the burner lighting tube. You generate the energy for the spark by pushing in the control knob and turning to "START/HI". This will ignite the smoker burner.*

**⚠ WARNING:** Check hose before each use of grill for nicks, cracking, abrasions or cuts. If the hose is found to be damaged in any way, do not use the grill. Replace using only Weber® authorized replacement hose. Contact the Customer Service Representative in your area using the contact information on our web site. Log onto [www.weber.com](http://www.weber.com)®.

- 1) Open the grill lid.
- 2) Open smoker box lid.
- 3) Fill smoker with water soaked wood chunks or chips.
- 4) Make sure that all burner control knobs not being used are turned to "OFF". (Push control knob in and turn clockwise to ensure that it is in the "OFF" position).

**⚠ WARNING:** The burner control knobs must be in the "OFF" position before turning on the liquid propane cylinder tank valve. If they are not in the "OFF" position, when you turn on the LP cylinder valve, the "excess gas flow control" feature will activate, limiting the flow of gas from the LP cylinder. If this should occur, turn off the LP cylinder valve and burner control knobs. Then start over.

### ⚠ DANGER

When the "excess gas flow control" feature is activated, a small amount of gas is still flowing to the burners. After turning off the cylinder and burner control knobs, wait at least 5 minutes for the gas to clear before attempting to light the grill. Failure to do so may result in an explosive flare-up, which can cause serious bodily injury or death.

- 5) Turn the cylinder on by turning the cylinder valve counter-clockwise.

**⚠ WARNING:** Do not lean over the open grill while lighting.

- 6) Push the control knob in and turn to "START/HI" until you hear the igniter snap - continue to hold control knob in for two seconds. This action will spark the igniter, the burner lighting tube and then main burner.
- 7) Check that the burner is lit by looking through the cooking grates. You should see a flame. If burner does not light on first try, push control knob in and turn to OFF. Repeat lighting procedure a second time

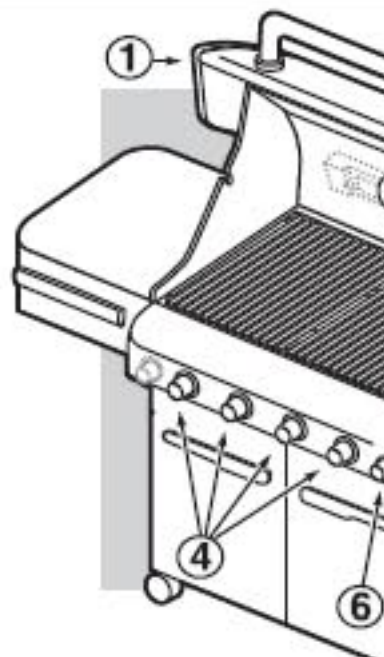

\*The grill illustrated may have slight differences than the model purchased.



### ⚠ DANGER

If the smoker burner still does not light, turn the burner control knob to "OFF" and wait 5 minutes for the gas to clear before you try again, or see "Manually Lighting the Smoker Burner".

- 8) Close smoker cover after wood starts smoking.

## TO EXTINGUISH

Push in and turn each burner control knob to "OFF" at the source.

## MANUALLY LIGHTING THE SMOKER BURNER

**⚠ WARNING:** Check hose before each use of grill for nicks, cracking, abrasions or cuts. If the hose is found to be damaged in any way, do not use the grill. Replace using only Weber® authorized replacement hose. Contact the Customer Service Representative in your area using the contact information on our web site. Log onto [www.weber.com](http://www.weber.com)®.

- 1) Open the lid.

### ⚠ DANGER

Failure to open the lid while igniting the grill, or not waiting 5 minutes to allow the gas to clear if the grill does not light, may result in an explosive flare-up which can cause serious bodily injury or death.

- 2) Open smoker box lid.
- 3) Fill smoker with water soaked wood chunks or chips.
- 4) Make sure that all burner control knobs not being used are turned to "OFF". (Push control knob in and turn clockwise to ensure that it is in the "OFF" position).

**⚠ WARNING:** The burner control knobs must be in the "OFF" position before turning on the liquid propane cylinder tank valve. If they are not in the "OFF" position, when you turn on the LP cylinder valve, the "excess gas flow control" feature will activate, limiting the flow of gas from the LP cylinder. If this should occur, turn off the LP cylinder valve and burner control knobs. Then start over.

### ⚠ DANGER

When the "excess gas flow control" feature is activated, a small amount of gas is still flowing to the burners. After turning off the cylinder and burner control knobs, wait at least 5 minutes for the gas to clear before attempting to light the grill. Failure to do so may result in an explosive flare-up, which can cause serious bodily injury or death.

- 5) Turn the cylinder on by turning the cylinder valve counter-clockwise.
- 6) Put a match in the match holder and strike the match.
- 7) Insert match holder and lit match down through cooking grates and Flavorizer® bars to ignite smoker burner.

**⚠ WARNING:** Do not lean over the open grill while lighting.

- 8) Push smoker burner control knob in and turn to "START/HI".
- 9) Check that the burner is lit by looking down through the cooking grate.

### ⚠ DANGER

If the smoker burner does not light, turn the burner control knob to "OFF" and wait 5 minutes to let the gas clear before you try again.

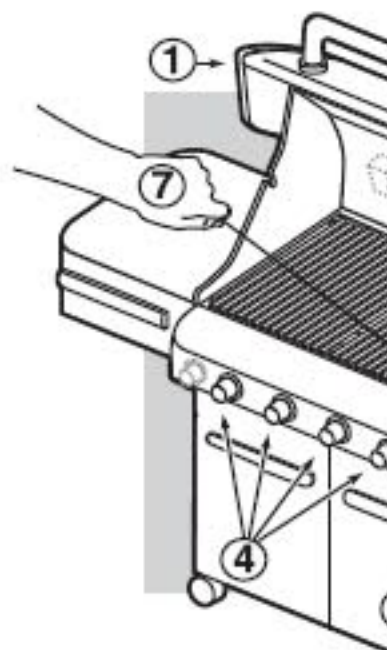

\*The grill illustrated may have slight differences than the model purchased.



- 10) Close smoker cover after wood starts smoking.

## TO EXTINGUISH

Push in and turn each burner control knob off at the source.

# OPERATING INSTRUCTIONS

## USING THE ROTISSERIE

*Note: Before using your rotisserie, measure your food at the widest point. If it exceeds 9½" (241.8mm), it is too large to fit the rotisserie. If it is too large, food can be prepared using a roast holder and the Indirect Cooking Method.*

## IMPORTANT SAFEGUARDS

### ⚠ WARNINGS

- Read all instructions before using your rotisserie.
- This rotisserie is for outdoor use only.
- Remove motor and store in a dry place when not in use.
- Do not touch hot surfaces. Use barbecue mitts.
- This rotisserie is not for use by children.
- To protect against electrical hazards do not immerse cord, plugs, or motor in water or other liquids.
- Unplug the motor from outlet when not in use or before cleaning.
- Do not use rotisserie for other than intended use.
- Make sure motor is off before placing it on the motor bracket.
- Do not operate the rotisserie motor with a damaged cord or plug.
- Do not operate the rotisserie motor if it should malfunction.
- The rotisserie motor is equipped with a three prong (grounding) power cord for your protection against shock hazard.
- The power cord should be plugged directly into a properly grounded three prong receptacle. If use of an extension cord is required, be sure that it is a minimum 16 AWG(1.3mm), 3-wire, well insulated cord marked for **OUTDOOR USE ONLY** and properly grounded.
- When using an extension cord, make sure it is not in contact with a hot or sharp surface.
- Outdoor extension cords should be marked with the letters "W-A" and a tag stating "Suitable for use with outdoor appliances".
- Do not cut or remove the grounding prong from the rotisserie motor power cord.
- Do not let cord hang over any sharp edge or hot surface.
- Do not expose to rain.
- To reduce the risk of electric shock, keep extension cord connection dry and off the ground.
- A short power cord is supplied to reduce the risk of tripping over the cord. Extension cords may be used, but caution must be taken to prevent tripping over the cord.
- In absence of local codes the rotisserie motor must be grounded electrically in accordance with the National Electric Code, ANSI / NFPA 70, or Canadian Electrical Code, CSA C22.1.

**⚠ WARNING: Setup up the rotisserie burner.**

## OPERATING

- 1) Remove rotisserie shaft from grill. F
- 2) Push the rotisserie shaft through the
- 3) Slide the spit fork onto the shaft. Ins  
The food should be centered on the
- 4) Place the motor in the bracket, slide
- 5) Insert the pointed end of the rotisse  
of the rotisserie onto the support ro
- 6) The rotisserie shaft should rotate so  
rotates down to the bottom. Large o  
grates and warming rack to allow fu  
necessary for better balance.
- 7) Turn the motor on.

## COOKING

- Meats (except poultry and ground m  
before cooking. (20 to 30 minutes s  
defrost completely before cooking.)
- Tie meat or poultry with a string, if n  
possible before putting it on the spit
- Remove cooking grates and warmi
- Follow lighting instructions for rotiss
- Set rotisserie burner on medium-hig
- Place food within area of burner.
- If you wish to save drippings for gra  
top of the Flavorizer® bars.
- Food preparation steps are the sam
- All cooking is done with the lid close
- If foods are too heavy or are irregul  
be cooked by the Indirect Method w
- Smoker can be used in conjunction

*Note: When using the rotisserie burner, g  
temperature inside the cooking box.*

## LIGHTING THE ROTISSERIE BURNER

### ROTISSERIE BURNER SNAP IGNITION

*Note: Each control knob snap igniter creates a spark from the igniter electrode to the burner lighting tube. You generate the energy for the spark by pushing in the control knob and turning to "START/HI". This will ignite each individual burner.*

#### ⚠ ATTENTION: READ BEFORE LIGHTING ROTISSERIE BURNER

After a period of non-use, before lighting the Rotisserie Burner, a few seconds must pass for the gas supply line to fill.

When using the snap igniter you will see a flash of flames moving from left to right across the Rotisserie Burner surface, the Rotisserie Burner is not lit until the entire ceramic surface is aflame.

At this point, start a count of 20 seconds before releasing the Rotisserie Burner control knob.

The Rotisserie Burner surface will glow red once the burner is fully ignited.

#### ⚠ DANGER

Failure to open the lid while igniting the grill, or not waiting 5 minutes to allow the gas to clear if the grill does not light, may result in an explosive flare-up which can cause serious bodily injury or death.

⚠ CAUTION: The Rotisserie Burner flame may be difficult to see on a bright sunny day.

⚠ WARNING: Check hose before each use of grill for nicks, cracking, abrasions or cuts. If the hose is found to be damaged in any way, do not use the grill. Replace using only a Weber® authorized replacement hose. Contact the Customer Service Representative in your area using the contact information on our web site.

Log onto [www.weber.com](http://www.weber.com)®.

- 1) Open the lid.
- 2) Remove the warming rack and the cooking grates from the cookbox.
- 3) Make sure all burner control knobs are turned off. (Push control knob in and turn clockwise to ensure that it is in the "OFF" position.)

⚠ WARNING: The burner control knobs must be in the "OFF" position before turning on the liquid propane cylinder tank valve. If they are not in the "OFF" position, when you turn on the LP cylinder valve, the "excess gas flow control" feature will activate, limiting the flow of gas from the LP cylinder. If this should occur, turn off the LP cylinder valve and burner control knobs. Then start over.

#### ⚠ DANGER

When the "excess gas flow control" feature is activated, a small amount of gas is still flowing to the burners. After

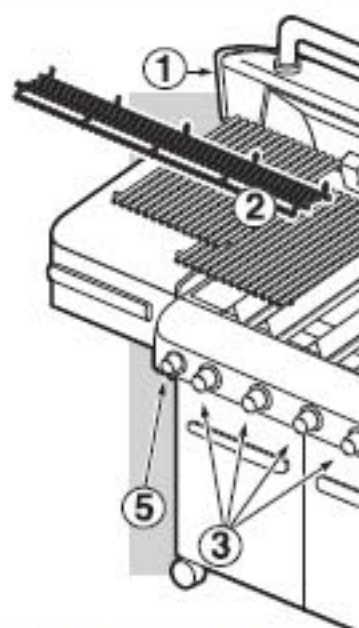

\*The grill illustrated may have slight differences than the model purchased.



- 4) Turn the cylinder on by turning the

⚠ WARNING: Do not lean over

- 5) Push the control knob in and turn to igniter and light the Rotisserie Burner. The Rotisserie Burner has ignited. Release the control knob.
- 6) Check that the burner is lit by looking

⚠ WARNING: If the rotisserie burner control knob to "OFF" position, allow the gas clear before you try again.

*Note: When using the rotisserie with the liquid propane cylinder tank valve, turn on each side of the food (See Grilling Method). Turn the rotisserie periodically to prevent over cooking on top. Turn the rotisserie when the food has browned to the desired color.*

#### TO EXTINGUISH

Push in and turn the rotisserie burner control knob to "OFF" and turn the gas supply off at the source.

# OPERATING INSTRUCTIONS

## MANUALLY LIGHTING THE ROTISSERIE BURNER

### ⚠ ATTENTION: READ BEFORE LIGHTING ROTISSERIE BURNER

After a period of non-use, before lighting the Rotisserie Burner, a few seconds must pass for the gas supply line to fill. When holding a match to the rotisserie burner you will see a flash of flames moving from left to right across the Rotisserie Burner surface, the Rotisserie Burner is not lit until the entire ceramic surface is aflame. At this point, start a count of 20 seconds before releasing the Rotisserie Burner control knob. The Rotisserie Burner surface will glow red once the burner is fully ignited.

### ⚠ DANGER

Failure to open the lid while igniting the grill, or not waiting 5 minutes to allow the gas to clear if the grill does not light, may result in an explosive flare-up which can cause serious bodily injury or death.

⚠ CAUTION: The Rotisserie Burner flame may be difficult to see on a sunny day.

⚠ WARNING: Check hose before each use of grill for nicks, cracking, abrasions or cuts. If the hose is found to be damaged in any way, do not use the grill. Replace using only a Weber® authorized replacement hose. Contact the Customer Service Representative in your area using the contact information on our web site. Log onto [www.weber.com](http://www.weber.com)®.

- 1) Open the lid.
- 2) Remove the warming rack and the cooking grates from the cookbox.
- 3) Make sure all burner control knobs are turned off. (Push control knob down and turn clockwise to ensure that it is in the "OFF" position.)

⚠ WARNING: The burner control knobs must be in the "OFF" position before turning on the liquid propane cylinder tank valve. If they are not in the "OFF" position, when you turn on the LP cylinder valve, the "excess gas flow control" feature will activate, limiting the flow of gas from the LP cylinder. If this should occur, turn off the LP cylinder valve and burner control knobs. Then start over.

### ⚠ DANGER

When the "excess gas flow control" feature is activated, a small amount of gas is still flowing to the burners. After turning off the cylinder and burner control knobs, wait at least 5 minutes for the gas to clear before attempting to light the grill. Failure to do so may result in an explosive flare-up, which can cause serious bodily injury or death.

E/S-450

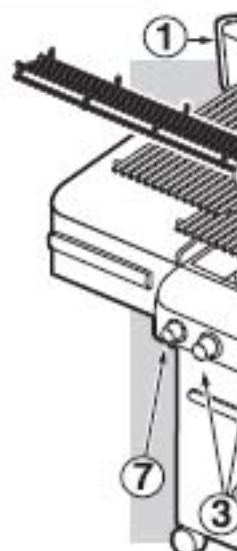

\*The grill illustrated may have slight differences than the model purchased.



- 4) Turn the cylinder on by turning the
- 5) Put a match in the match holder and
- 6) Hold match holder and lit match by

⚠ WARNING: Do not lean over

- 7) Push rotisserie burner control knob hold the control knob down until tw
- 8) Check that the burner is lit by lookin

⚠ WARNING: If the rotisserie burner control knob to "OFF" gas clear before you try ag

Note: When using the rotisserie with the lid closed, place a metal foil shield under the food (See Grilling Methods-Instructions) to prevent over cooking on the outside. Turn the rotisserie until the food is browned to the desired color. Finish cooking with the lid open.

### TO EXTINGUISH

Push in and turn the rotisserie burner control knob clockwise to the "OFF" position. Turn the LP cylinder valve off at the source.

PROBLEM	CHECK	
Rotisserie burner does not light.	Did you hold the burner control knob in and hold in for 20 seconds until after burner ignited?	Try to relight burner by holding burner 20 seconds after burner has ignited.
	Did you wait to see the entire ceramic surface become alight before counting 20 seconds?	When relighting burner by holding burner, ceramic surface become alight before counting 20 seconds.
	Did you repeatedly use the snap ignition until the burner ignited?	After waiting five minutes for gas to clear, the burner ignites (refer to "Lighting the Burner").
	Does the igniter work (Do you see a spark when you repeatedly use the snap igniter)?	Try manually lighting the burner (refer to customer service).
<b>General Symptoms:</b> Burner does not light. -or- Burner has a small flickering flame	The excess flow safety device, which is part of the barbecue to cylinder connection, may have activated.	To reset the excess flow safety device, turn the regulator knob to "OFF". Disconnect the regulator from the gas cylinder. Turn the regulator knob to "START/HI". Wait at least 1 minute. Reconnect the regulator to the cylinder. Refer to "Lighting Instructions".
If problems cannot be corrected by using these methods, please contact the Customer Service Representative in your area. Log onto <a href="http://www.weber.com">www.weber.com</a> .		

## OPERATING THE HANDLE LIGHT

The Weber Grill Out™ Handle Light has a built-in "Tilt Sensor." With the power button (a) activated, the light will come on when the grill lid is open. The light will turn off when the lid is closed. For daytime use, deactivate the sensor by pressing power button (a).

## HANDLE LIGHT TROUBLESHOOTING

PROBLEM	CHECK	
Weber Grill Out™ Handle Light does not light.	Are the batteries old?	Replace batteries.
	Are the batteries installed correctly?	See assembly instructions.
	Is the lid in the up position with the power button ON?	Light will come on.
	Is the Weber Grill Out™ Handle Light activated?	Press power button (a).
	Is the Weber Grill Out™ Handle Light positioned correctly on the handle?	Adjust position.
If problems cannot be corrected by using these methods, please contact the Customer Service Representative in your area. Log onto <a href="http://www.weber.com">www.weber.com</a> .		

## SIDEBURNER TROUBLESHOOTING

PROBLEM	CHECK	
Side Burner does not light.	Is gas supply off?	Turn supply on.
	The excess flow safety device, which is part of the barbecue to cylinder connection, may have activated.	To reset the excess flow safety device, turn the regulator knob to "OFF". Disconnect the regulator from the gas cylinder. Turn the regulator knob to "START/HI". Wait at least 1 minute. Reconnect the regulator to the cylinder. Refer to "Lighting Instructions".

# SIDEBURNER MAINTENANCE

## SIDE BURNER MAINTENANCE

**⚠ WARNING:** All gas controls and supply valves should be in the "OFF" position.

Make sure black wire is connected between the igniter and electrode.  
Make sure white wire is connected between the igniter and grounding clip.  
Spark should be a white/blue color, not yellow.

- 1) Igniter Wire
- 2) Ground wire
- 3) Burner

Side Burner Grate  
Side Burner cap  
Side Burner Ring & Head  
Igniter Electrode  
Control Knob  
Igniter

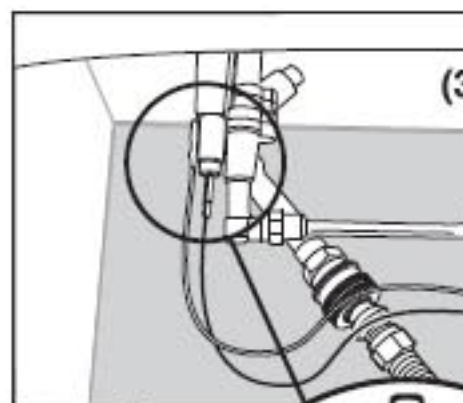
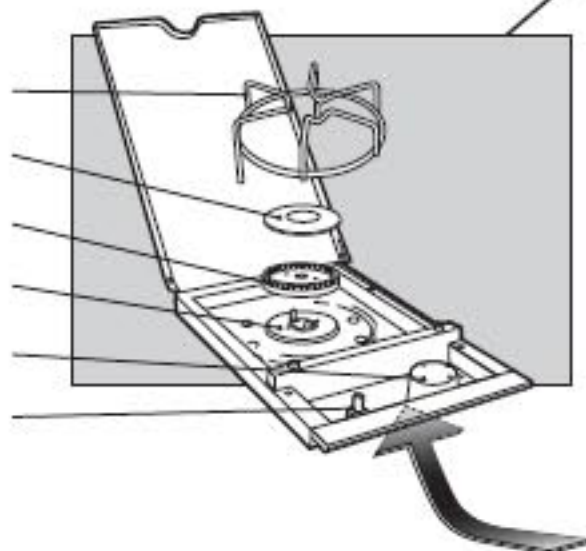

## TROUBLESHOOTING

PROBLEM	CHECK	
Burners burn with a yellow or orange flame, in conjunction with the smell of gas (This is normal for the burner lighting tube).	Inspect Spider/Insect Screens for possible obstructions. (Blockage of holes.)	Clean Spider/Insect Screens.
<b>Symptoms:</b> Burners do not light. -or- Burners have a small flickering flame in the "HI" position. -or- Barbecue temperature only reaches 250° to 300° in the "HI" position.	The excess flow safety device, which is part of the barbecue to cylinder connection, may have activated.	To reset the excess flow safety device, turn the control knobs and the gas cylinder valve off for at least 1 minute. Reconnect the gas cylinder to the barbecue on slowly. Refill the cylinder.
Burner does not light, or flame is low in "HI" position.	Is LP fuel low or empty?	Refill LP cylinder.
	Is fuel hose bent or kinked?	Straighten fuel hose.
	Does Burner light with a match?	If you can light with a match, use the Crossover® igniter.
	Did you use the snap igniter several times until the main burner lit (See Lighting Instructions)?	Make sure to use the snap igniter several times before snapping the main burner lighting tube.
	Does the igniter work (Do you see a spark when you repeatedly use the snap igniter)?	Try manually lighting the burner using the Manual Lighting Tube.
Experiencing flare-ups:	Are you preheating barbecue in the prescribed manner?	All burners on for 5 minutes.
	Are the cooking grates and Flavorizer® bars heavily coated with burned-on grease?	Clean thoroughly.

## WEBER® SPIDER/INSECT SCREENS

Your Weber® gas barbecue, as well as any outdoor gas appliance, is a target for spiders and other insects. They can nest in the venturi section (1) of the burner tubes. This blocks the normal gas flow, and can cause the gas to flow back out of the combustion air opening. This could result in a fire in and around the combustion air openings, under the control panel, causing serious damage to your barbecue.

The burner tube combustion air opening is fitted with a stainless steel screen (2) to prevent spiders and other insects access to the burner tubes through the combustion air openings.

**We recommend that you inspect the Spider/Insect screens at least once a year. (See Section "Annual Maintenance".) Also inspect and clean the the Spider/Insect screens if any of the following symptoms should ever occur:**

- 1) The smell of gas in conjunction with the burner flames appearing yellow and lazy.
- 2) Barbecue does not reach temperature.
- 3) Barbecue heats unevenly.
- 4) One or more of the burners do not ignite.

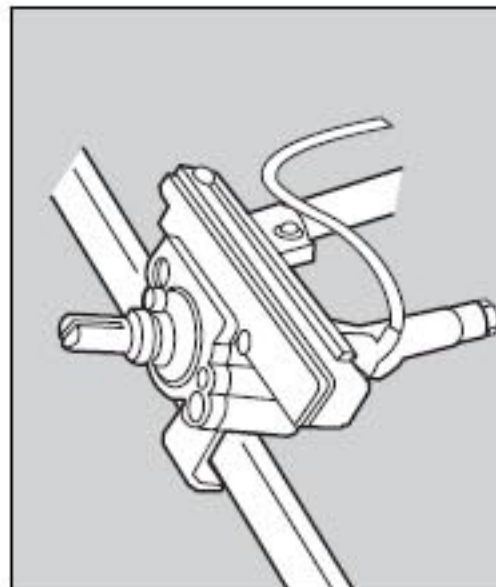

### ⚠ DANGER

**Failure to correct the above mentioned symptoms may result in a fire, which can cause serious bodily injury or death, and cause damage to property.**

## MAIN BURNER CLEANING PROCEDURE

**Turn off the gas supply.**

Remove the manifold (See "Replace Main Burners").

Lock inside each burner with a flashlight.

Clean the inside of the burners with a wire (a straightened-out coat hanger will work).

Check and clean the air shutter opening at the ends of the burners. Check and clean the valve orifices at the base of the valves. Use a Steel bristle brush to clean outside of burners. This is to make sure all the burner ports are fully open.

**⚠ CAUTION: Do not enlarge the burner ports when cleaning.**

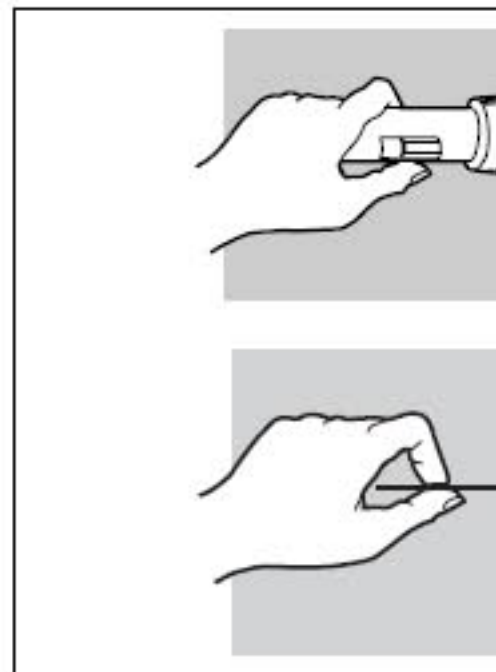

## REPLACE MAIN BURNERS

- 1) Your Summit® gas grill must be off and cool.
- 2) Turn gas off at source.
- 3) Disconnect gas supply.
- 4) Remove cooking grates.
- 5) Remove smoker box.
- 6) Remove Flavorizer® bars.

## REMOVE CONTROL PANEL

- 7) Tool required: Phillips Screwdriver.
  - a) Remove the burner control knobs.

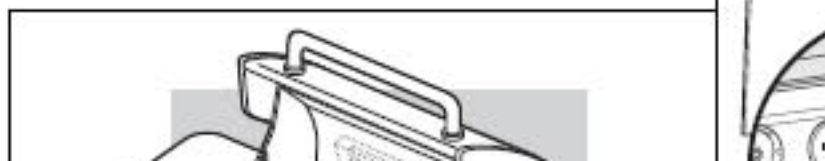

# MAINTENANCE

- 9) Pull the selected burner(s) tube(s) from manifold frame and replace with a new burner tube.
- 10) To reinstall the manifold assembly, reverse steps 7 through 9.

**⚠ CAUTION:** The burner openings (A) must be positioned properly over the valve orifices (B).

Make sure the opposite end of the burner tubes (C) properly align into the slots on the backside of the cookbox. Check proper assembly before fastening manifold in place.

**⚠ WARNING:** After reinstalling the gas lines, they should be leak checked with a soap and water solution before using the grill. (See, "Check for gas leaks.")

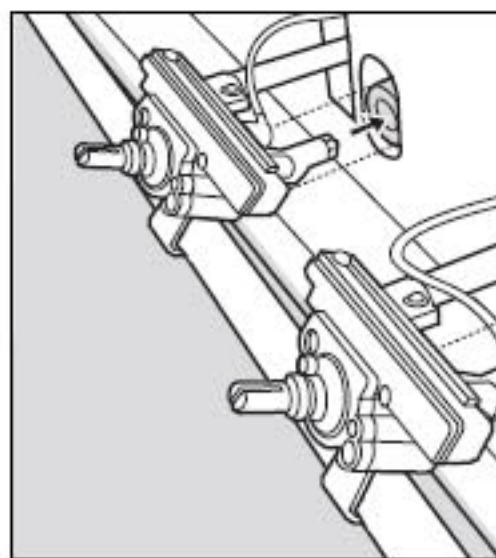
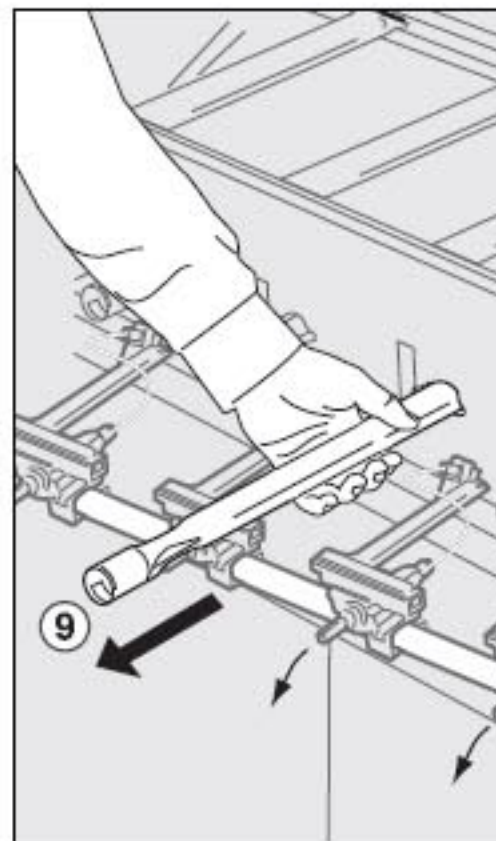
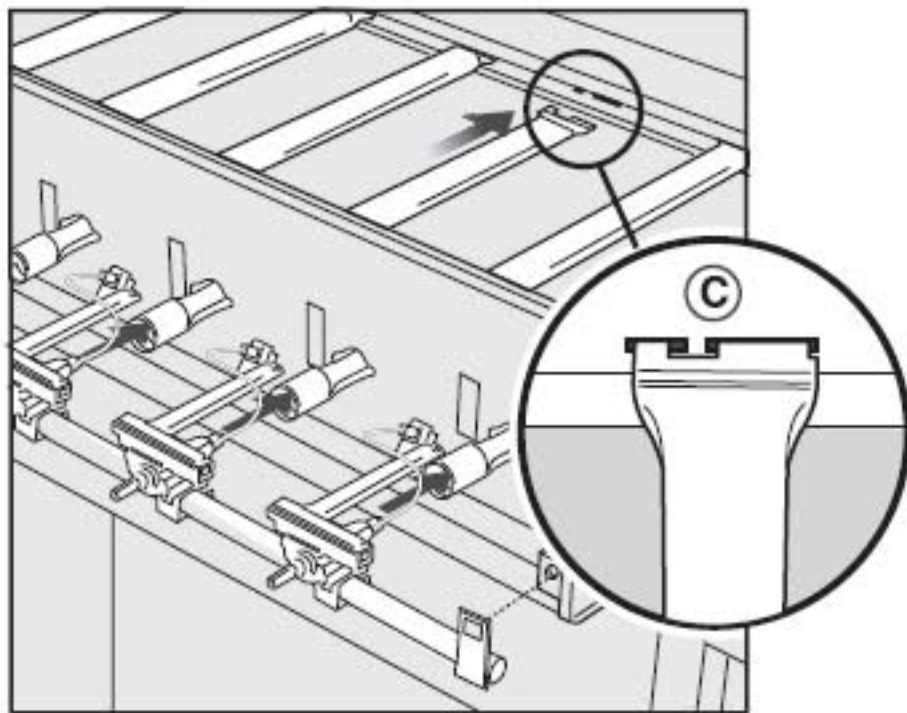

## ANNUAL MAINTENANCE

### INSPECTION AND CLEANING OF THE SPIDER/INSECT SCREENS

To inspect the Spider/Insect screens, remove the control panel. If there is dust or dirt on the screens, remove the burners for cleaning the screens.

Brush the Spider/Insect screens lightly with a soft bristle brush (i.e. an old toothbrush).

**⚠ CAUTION:** Do not clean the Spider/Insect screens with hard or sharp tools. Do not dislodge the Spider/Insect screens or enlarge the screen openings.

Lightly tap the burner to get debris and dirt out of the burner tube. Once the Spider/Insect screens and burners are clean replace the burners.

If the Spider/Insect screen becomes damaged or cannot be cleaned, please contact the Customer Service Representative in your area using the contact information on our web site. Log onto [www.weber.com](http://www.weber.com).

