

# SUMMIT®



## GAS GRILL

### Natural Gas Grill Owner's Guide

Guía del Propietario de la Barbacoa de Gas Natural - Pg 32

Guide de l'utilisateur du barbecue au gaz naturel - Pg 53

Assembly, Ensamblaje, Assemblage - Pg 9

E/S-420/450

#89561



**YOU MUST READ THIS OWNER'S GUIDE BEFORE OPERATING YOUR GAS GRILL**

#### ⚠ DANGER

If you smell gas:

1. Shut off gas to the appliance.
2. Extinguish any open flames.
3. Open lid.
4. If odor continues, keep away from the appliance and immediately call your gas supplier or your fire department.

Leaking gas may cause a fire or explosion which can cause serious bodily injury or death, or damage to property.

#### ⚠ WARNING:

1. Do not store or use gasoline or other flammable liquids or vapors in the vicinity of this or any other appliance.
2. An LP cylinder not connected for use shall not be stored in the vicinity of this or any other appliance.

⚠ **WARNING:** Follow all leak-check procedures carefully in this manual prior to barbecue operation. Do this even if the barbecue was dealer-assembled.

**NOTICE TO INSTALLER:** These instructions must be left with the owner and the owner should keep them for future use.

**THIS GAS APPLIANCE IS DESIGNED FOR OUTDOOR USE ONLY.**

⚠ **WARNING:** Do not try to light this appliance without reading the "Lighting Instructions" section of this manual.



89561 US 03/03/08

NG

US ENGLISH



**⚠ DANGER**

Failure to follow the Dangers, Warnings and Cautions contained in this Owner's Manual may result in serious bodily injury or death, or in a fire or an explosion causing damage to property.

**⚠ WARNINGS**

- ⚠ Do not store a spare or disconnected liquid propane cylinder under or near this barbecue.
- ⚠ Improper assembly may be dangerous. Please follow the assembly instructions carefully.
- ⚠ After a period of storage, and/or nonuse, the Weber® gas barbecue should be checked for gas leaks and burner obstructions before use. See instructions in this manual for correct procedures.
- ⚠ Do not operate the Weber® gas barbecue if there is a gas leak present.
- ⚠ Do not use a flame to check for gas leaks.
- ⚠ Combustible materials should never be within 24 inches (61 cm) of the back or sides of your Weber® gas barbecue.
- ⚠ Do not put a barbecue cover or anything flammable on, or in the storage area under the barbecue.
- ⚠ Your Weber® gas barbecue should never be used by children. Accessible parts of the barbecue may be very hot. Keep young children away while it is in use.
- ⚠ You should exercise reasonable care when operating your Weber® gas barbecue. It will be hot during cooking or cleaning and should never be left unattended, or moved while in operation.
- ⚠ Should the burners go out while in operation, turn all gas valves off. Open the lid and wait five minutes before attempting to relight, using the lighting instructions.
- ⚠ Do not use charcoal or lava rock in your Weber® gas barbecue.
- ⚠ Never lean over open grill or place hands or fingers on the front edge of the cooking box.
- ⚠ Should a grease fire occur, turn off all burners and leave lid closed until fire is out.
- ⚠ Do not enlarge valve orifices or burner ports when cleaning the valves or burners.
- ⚠ The Weber® gas barbecue should be thoroughly cleaned on a regular basis.
- ⚠ Liquid propane gas is not natural gas. The conversion or attempted use of natural gas in a liquid propane unit or liquid propane gas in a natural gas unit is dangerous and will void your warranty.
- ⚠ Do not attempt to disconnect any gas fitting while your barbecue is in operation.
- ⚠ Use heat-resistant barbecue mitts or gloves when operating barbecue.
- ⚠ Keep any electrical supply cord and the fuel supply hose away from any heated surfaces.
- ⚠ Combustion byproducts produced when using this product contain chemicals known to the state of California to cause cancer, birth defects, or other reproductive harm.
- ⚠ Do not use this barbecue unless all parts are in place. The unit must be properly assembled according to the assembly instructions.
- ⚠ Do not build this model of grill in any built-in or slide in construction. Ignoring this Warning could cause a fire or an explosion that can damage property and cause serious bodily injury or death.
- ⚠ Proposition 65 Warning: Handling the brass material on this product exposes you to lead, a chemical known to the state of California to cause cancer, birth defects or other reproductive harm.  
(Wash hands after handling this product.)

**LIQUID PROPANE GAS UNITS ONLY:**

- ⚠ Use the pressure regulator and hose assembly that is supplied with your Weber® gas barbecue.
- ⚠ Do not attempt to disconnect the gas regulator and hose assembly or any gas fitting while your barbecue is in operation.
- ⚠ A dented or rusty liquid propane cylinder may be hazardous and should be checked by your liquid propane supplier. Do not use a liquid propane cylinder with a damaged valve.
- ⚠ Although your liquid propane cylinder may appear to be empty, gas may still be present, and the cylinder should be transported and stored accordingly.
- ⚠ If you see, smell or hear the hiss of escaping gas from the liquid propane cylinder:
  1. Move away from liquid propane cylinder.
  2. Do not attempt to correct the problem yourself.
  3. Call your fire department.



Weber-Stephen Products Co. (Weber) hereby warrants to the ORIGINAL PURCHASER of this Weber® gas grill that it will be free of defects in material and workmanship from the date of purchase as follows:

Aluminum castings	25-years (2 years on paint; excludes fading)
Stainless steel Shroud,	25-years
Porcelain-enamelled shroud,	25-years
Cookbox Assembly	10-years (2 year on paint excludes fading)
Stainless steel burners tubes,	10-years
Stainless steel cooking grates,	5-years no rust through or burn through
Stainless steel Flavorizer bars,	5-years no rust through or burn through
Porcelain-enamelled cast-iron	
cooking grates,	5-year no rust through or burn through
Porcelain-enamelled	
cooking grates,	3-years no rust through or burn through
Porcelain-enamelled	
Flavorizer bars,	2-years no rust through or burn through
Infrared Rotisserie Burner,	2-years
All remaining parts,	2-years

When assembled and operated in accordance with the printed instructions accompanying it. Weber may require reasonable proof of your date of purchase. THEREFORE, YOU SHOULD RETAIN YOUR SALES SLIP OR INVOICE.

This Limited Warranty shall be limited to the repair or replacement of parts that prove defective under normal use and service and which on examination shall indicate, to Weber's satisfaction, they are defective. Before returning any parts, contact the Customer Service Representative in your area using the contact information on our website. If Weber confirms the defect and approves the claim, Weber will elect to replace such parts without charge. If you are required to return defective parts, transportation charges must be prepaid. Weber will return parts to the purchaser, freight or postage prepaid.

Weber-Stephen Products Co., (Weber) mediante la presente le garantiza al COMPRADOR ORIGINAL de esta barbacoa de gas Weber® que la misma estará libre de defectos en cuanto a materiales y fabricación a partir de la fecha de compra según lo siguiente:

Piezas coladas de aluminio	25-años (2 años para la pintura excluyendo la decoloración)
Cubierta de acero inoxidable,	25-años
Cubierta porcelanizada,	25-años
Cámara para asar	10-años (2 años para la pintura excluyendo la decoloración)
Tubos de acero inoxidable	
de los quemadores,	10-años
Parrillas de cocción de	
acero inoxidable,	5-años sin perforación por fuego u oxidación
Barra Flavorizer de	
acero inoxidable,	5-años sin perforación por fuego u oxidación
Parrillas de cocción de hierro	
colado porcelanizado,	5-años sin perforación por fuego u oxidación
Parrillas de cocción porcelanizadas,	3-años sin perforación por fuego u oxidación
Barra Flavorizer porcelanizadas,	2-años sin perforación por fuego u oxidación
Queador infrarrojo del	
asador giratorio,	2-años
Todas la demás partes,	2-años

cuando se ensambla y opera de acuerdo a las instrucciones impresas que la acompañan. Weber pudiese requerir prueba razonable de la fecha de compra. POR LO TANTO, DEBERÁ GUARDAR SU RECIBO O FACTURA DE VENTA.

Esta garantía limitada está limitada a la reparación o reemplazo de piezas que resultasen defectuosas bajo uso y servicio normal y las cuales al examinarse indiquen, a plena satisfacción de Weber, que efectivamente son piezas defectuosas. Antes de devolver cualquier parte, contacte al Representante de Atención al Cliente en su área, cuya información de contacto la encontrará en nuestro sitio web. Si Weber confirma el defecto y aprueba el reclamo, ésta elegirá reparar o reemplazar tal pieza sin cargo alguno. Si usted tiene que retornamos las partes defectuosas, los gastos de transporte deben ser prepagados. Weber retornará las partes al comprador con transporte o franqueo prepagado. Esta Garantía Limitada no cubre ninguna falla o problema de operación a causa de accidentes, abuso, mal uso, alteración, uso en aplicaciones indebidas, vandalismo, instalación inapropiada o mantenimiento o servicio inapropiados, o por no llevar a cabo el mantenimiento normal y rutinario, entre los que se incluyen, pero sin limitación, los daños causados por insectos dentro de los tubos quemadores, según se detalla en este manual del propietario.

Weber-Stephen Products Co. (Weber) garantit par le présent document à l'ACHETEUR D'ORIGINE de ce grill à gaz Weber® que celui-ci ne comportera aucun défaut de pièce ni de main d'oeuvre à compter de la date d'achat comme suit :

Fente d'aluminium	25 ans (2 ans pour la peinture à l'exception de toute décoloration)
Structure en acier inoxydable,	25 ans
Structure émaillée,	25 ans
Cuve,	10 ans (2 ans pour la peinture à l'exception de toute décoloration)
Tubos du brûleur en acier inoxydable,	10 ans
Grilles de cuisson en acier inoxydable,	5 ans sans trou provoqué par la rouille ou par une brûlure
Barra Flavorizer en acier inoxydable,	5 ans sans trou provoqué par la rouille ou par une brûlure
Grilles de cuisson en fonte fer émaillée,	5 ans sans trou provoqué par la rouille ou par une brûlure
Grilles de cuisson émaillées,	3 ans sans trou provoqué par la rouille ou par une brûlure
Barra Flavorizer émaillées,	2 ans sans trou provoqué par la rouille ou par une brûlure
Brûleur de la rôtissoire à infrarouge,	2 ans
Toutes les autres pièces,	2 ans

à condition qu'il ait été assemblé et utilisé conformément aux instructions imprimées qui l'accompagnent.

Weber peut exiger une preuve raisonnable de votre date d'achat. VOUS DEVRIEZ DONC CONSERVER VOTRE TICKET DE CAISSE OU VOTRE FACTURE.

La présente Garantie limitée est limitée à la réparation ou au remplacement des pièces qui s'avèrent défectueuses dans le cadre d'une utilisation normale et d'un entretien normal et dont l'examen indique, à la satisfaction de Weber, qu'elles sont défectueuses. Avant de retourner toute pièce, veuillez entrer en contact avec le Représentant du Service clientèle le plus proche grâce aux coordonnées à votre disposition sur notre site Internet. Si Weber confirme le défaut et approuve la demande, Weber choisira de remplacer ces pièces sans frais. S'il vous est demandé de retourner les pièces défectueuses, les frais de transport devront être prépayés. Weber retournera les pièces à l'acheteur, franco de port.

La présente Garantie limitée ne couvre pas toute défaillance ou difficulté d'utilisation provoquée par un accident, une utilisation abusive, une mauvaise utilisation, une altération, une mauvaise application, un acte de vandalisme, une installation incorrecte ou une maintenance ou un entretien incorrects, ou le défaut d'entretien normal et régulier, y compris mais pas seulement les dommages provoqués par des insectes à l'intérieur des tubes du brûleur, tel que décrit dans le présent mode d'emploi.

This Limited Warranty does not cover any failures or operating difficulties due to accident, abuse, misuse, alteration, misapplication, vandalism, improper installation or improper maintenance or service, or failure to perform normal and routine maintenance, including but not limited to damage caused by insects within the burner tubes, as set out in this owner's manual. Deterioration or damage due to severe weather conditions such as hail, hurricanes, earthquakes or tornadoes, discoloration due to exposure to chemicals either directly or in the atmosphere, is not covered by this Limited Warranty.

There are no other express warrants except as set forth herein and any applicable implied warranties of merchantability and fitness are limited in duration to the period of coverage of this express written Limited Warranty. Some regions do not allow limitation on how long an implied warranty lasts, so this limitation may not apply to you.

Weber is not liable for any special, indirect or consequential damages. Some regions do not allow the exclusion or limitation of incidental or consequential damages, so this limitation or exclusion may not apply to you.

Weber does not authorize any person or company to assume for it any other obligation or liability in connection with the sale, installation, use, removal, return, or replacement of its equipment; and no such representations are binding on Weber.

This Warranty applies only to products sold at retail.

**WEBER-STEPHEN PRODUCTS CO.**  
**Customer Service Center**  
**1890 Roselle Road, Suite 308**  
**Schaumburg, IL 60195**  
**USA**

**For replacement parts call:**  
**1-800-446-1071**  
**www.weber.com®**

Esta Garantía Limitada no cubre el deterioro o daños a causa de condiciones de tiempo inclemente tales como granizo, huracanes, terremotos o tornados ni tampoco la decoloración por exposición a sustancias químicas bien sea por contacto directo o por que las mismas contenidas en la atmósfera.

No existe ninguna otra garantía expresa que no sean las las acá indicadas y cualesquier garantías implícitas de comerciabilidad y aptitud de uso están limitadas en duración al tiempo de cobertura de esta expresa Garantía Limitada por escrito. Algunas regiones no permiten limitación alguna en el tiempo que una garantía implícita pueda durar, por lo que esta limitación pudiera no aplicarle a usted. Weber no se hace responsable de cualesquier daños especiales, indirectos o emergentes. Algunas regiones no permiten la exclusión o limitación de daños incidentales o emergentes, por lo que esta limitación o exclusión pudieran no aplicarle a usted.

Weber no autoriza a persona o empresa alguna a asumir en su nombre ninguna obligación o responsabilidad en relación con la venta, instalación, uso, retiro, devolución o reemplazo de sus equipos, y ninguna tal representación será vinculante para Weber.

Esta Garantía aplica solo a aquellos productos vendidos al por menor.

**WEBER-STEPHEN PRODUCTS CO.**  
**Customer Service Center**  
**1890 Roselle Road, Suite 308**  
**Schaumburg, IL 60195**  
**USA**

**Para partes de repuesto llame a:**  
**1-800-446-1071**  
**www.weber.com®**

**Para compras hechas en México**  
**WEBER-STEPHEN PRODUCTS S.A. de**  
**C.V.**  
**Marcella No. 338,**  
**Colonia Americana**  
**44160 México, C.P.**  
**México**

**Para partes de repuesto llame a:**  
**(52) (33) 3615-0736**  
**www.weber.com®**

Toute détérioration ou tout dommage résultant de conditions météorologiques graves comme de la grêle, des ouragans, des séismes ou des tornades, toute décoloration résultant d'une exposition à des agents chimiques directement ou dans l'atmosphère, n'est pas couverte dans le cadre de la présente Garantie limitée.

Il n'existe aucune autre garantie expresse hormis celles exposées dans le présent document et toute garantie de commercialisation et de bon état induite est limitée en durée à la période de couverture de la présente Garantie limitée écrite expresse. Certaines régions n'autorisent pas de limitation de durée de la garantie induite ; il est donc possible que cette limitation ne s'applique pas à vous.

Weber ne peut être tenu pour responsable de tout dommage particulier, induit ou se produisant par voie de conséquence. Certaines régions n'autorisent pas l'exclusion ou la limitation des dommages indirects ou se produisant par voie de conséquence ; il est donc possible que cette limitation ou exclusion ne s'applique pas à vous.

Weber n'autorise aucune personne ou société à présumer en son nom de toute autre obligation ou responsabilité en relation avec la vente, l'installation, l'utilisation, le retrait, le retour ou le remplacement de ses équipements ; et aucune de ces représentations ne lie Weber.











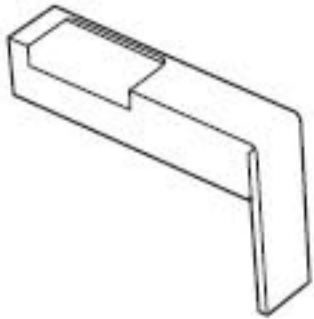
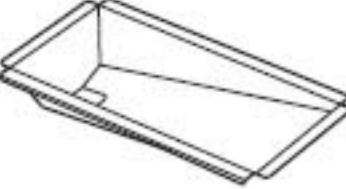

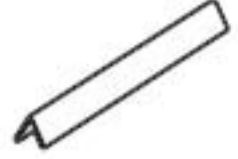
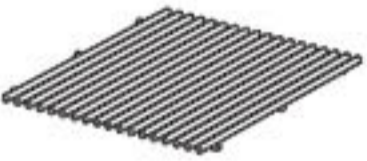

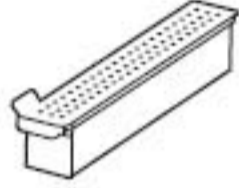

La présente Garantie s'applique uniquement aux produits vendus au détail.

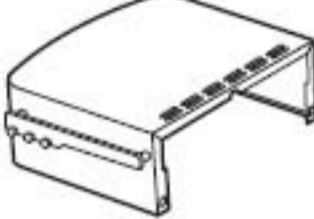
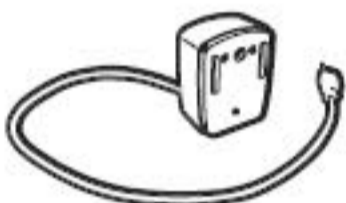
**WEBER-STEPHEN PRODUCTS CO.**  
**Product Registration**  
**P.O. Box 40530**  
**Burlington, ON L7P 4W1**

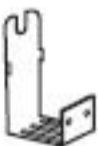
**Pour des pièces de rechange, appelez le :**

**1-800-265-2150**  
**www.weber.com®**



	420	450		420	450	
<b>Catch Pan Holder</b> Sostenedor del plato recolector Support de l'égouttoir	1	1		1	1	
<b>Catch Pan</b> Plato recolector Egouttoir	1	1		9	8	
<b>Cooking Grate</b> Parrilla de cocción Grille de cuisson	2	2		-	1	
<b>Warming Rack</b> Rejilla para calentar Grille de maintien au chaud	1	1		-	1	
<b>Rotisserie Fork</b> Horquilla del asador giratorio Fourche de la rôtissoire	-	4		1	1	
<b>Rotisserie Spit</b> Espetón del asador giratorio Brôche de la rôtissoire	-	1		1	1	
<b>Rotisserie Motor</b> Motor del asador giratorio Moteur de la rôtissoire	-	1		1	1	
<b>Rotisserie Bracket</b> Soporte del asador giratorio Support de la rôtissoire	-	1		4	4	
			<b>Truss Head Screw (1/4-20 x 1 inch)</b> Tornillo de cabeza segmentada (Tornillo 1/4-20 x 1 pulgadas) Vis à tête bombée large de (1/4-20 x 1 pouces)	4	4	
			<b>Keps Nut (1/4-20 keps nut)</b> Tuerca keps (Tuerca keps 1/4-20) Ecrou à rondelle dentée (écrou à rondelle dentée de 1/4-20)	-	2	
			<b>1 inch Bolt (1/4-20 x 1 inch Bolt)</b> Perno 1 pulgada (Perno 1/4-20 x 1 pulgadas) Ecrou de 1 pouce (écrou de 1/4-20 x 1 pouce)	-	2	
			<b>Screw</b> Tornillo Vis	3	3	
			<b>Plastic Plug</b> Tapón plástico Bouchon en plastique	3	3	



## VISION ÉCLATÉE, DIAGRAMA DE DESPIECE

E/S 420\_NG\_US

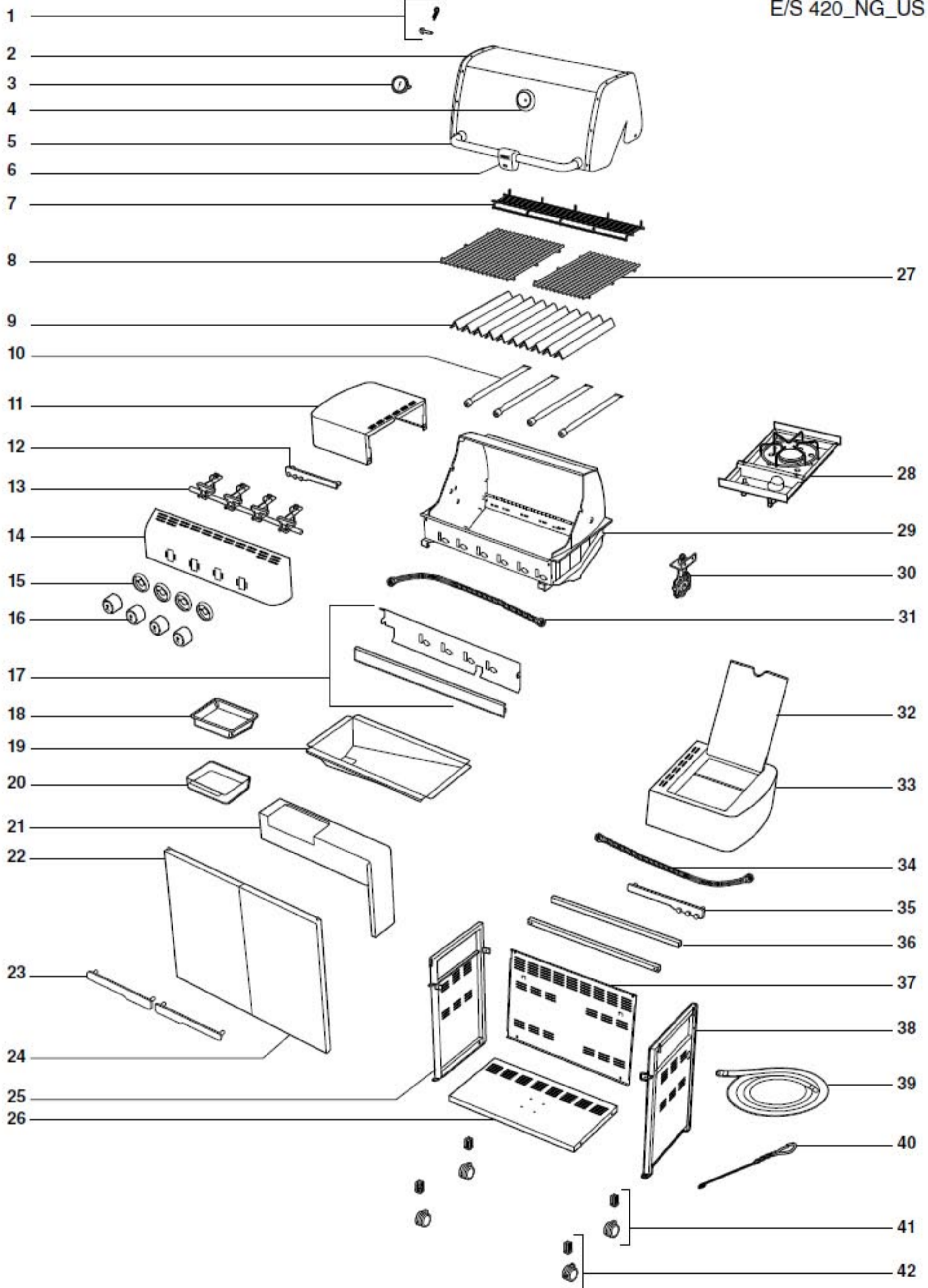



## LISTA DEL DIAGRAMA DE DESPIECE, LISTE DE LA VISION ÉCLATÉE

- |   |   |   |
|---|---|---|
| 1. <b>Shroud Hardware</b><br>Accesorios de la cubierta<br>Structure de protection                     | 16. <b>Knob</b><br>Perilla<br>Bouton  | 31. <b>Manifold Hose</b><br>Manguera del múltiple<br>Tuyau du collecteur                    |
| 2. <b>Shroud</b><br>Cubierta<br>Tôle de protection  | 17. <b>Water Baffle / Heat Shield</b><br>Reflector de agua / Pantalla térmica<br>Protection contre l'eau/Cloison anti-chaleur | 32. <b>Side Burner Lid</b><br>Tapa del quemador lateral<br>Couvercle du brûleur latéral     |
| 3. <b>Thermometer</b><br>Termómetro<br>Thermomètre  | 18. <b>Disposable Drip Pan</b><br>Bandeja de goteo desechable<br>Egouttoir jetable  | 33. <b>Side Burner Table</b><br>Mesa del quemador lateral<br>Tablette du brûleur latéral    |
| 4. <b>Thermometer Bezel</b><br>Moldura decorativa del termómetro<br>Plaque indicatrice du thermomètre | 19. <b>Drip Tray</b><br>Bandeja de goteo<br>Plateau-égouttoir   | 34. <b>Side Burner Hose</b><br>Manguera del quemador lateral<br>Tuyau du brûleur latéral    |
| 5. <b>Handle</b><br>Asa<br>Poignée  | 20. <b>Catch Pan</b><br>Plato recolector<br>Egouttoir   | 35. <b>Right Tool Holder</b><br>Portaherramientas derecho<br>Support d'ustensiles de droite |
| 6. <b>Grill Out™ Handle Light</b><br>Luz de asa Grill Out™<br>Lampe de poignée Grill Out™             | 21. <b>Catch Pan Holder</b><br>Soporte del plato recolector<br>Support d'égouttoir  | 36. <b>Frame Support</b><br>Soporte del bastidor<br>Support de cadre                        |
| 7. <b>Warming Rack</b><br>Rejilla de calentamiento<br>Grille de réchauffage                           | 22. <b>Left Door</b><br>Puerta izquierda<br>Porte gauche  | 37. <b>Back Panel</b><br>Panel trasero<br>Panneau arrière                                   |
| 8. <b>Cooking Grates</b><br>Parrillas de cocción<br>Grilles de cuisson                                | 23. <b>Door Handles</b><br>Asas de las puertas<br>Poignées de portes  | 38. <b>Right Frame Panel</b><br>Panel derecho del bastidor<br>Panneau du cadre droit        |
| 9. <b>Flavorizer® Bars</b><br>Barras Flavorizer®<br>Barres Flavorizer®                                | 24. <b>Right Door</b><br>Puerta derecha<br>Porte droite   | 39. <b>Natural Gas Hose</b><br>Manguera del gas natural<br>Tuyau de gaz naturel             |
| 10. <b>Burner Tubes</b><br>Tubos quemadores<br>Tubes des brûleurs                                     | 25. <b>Left Frame Panel</b><br>Panel izquierdo del bastidor<br>Panneau du cadre gauche  | 40. <b>Matchstick Holder</b><br>Portacerillos<br>Porte-allumette                            |
| 11. <b>Side Table</b><br>Mesa lateral<br>Tablette latérale  | 26. <b>Bottom Panel</b><br>Panel inferior<br>Panneau inférieur  | 41. <b>Caster</b><br>Rueda giratoria<br>Roulette  |
| 12. <b>Left Tool Holder</b><br>Portaherramientas izquierdo<br>Support d'ustensiles de gauche          | 27. <b>Cooking Grate</b><br>Rejilla de cocción<br>Grille de cuisson   | 42. <b>Locking Caster</b><br>Rueda giratoria con bloqueo<br>Roulette autobloquante          |
| 13. <b>Manifold</b><br>Múltiple<br>Collecteur   | 28. <b>Side Burner</b><br>Quemador lateral<br>Brûleur latéral   |   |
| 14. <b>Control Panel</b><br>Tablero de control<br>Panneau de commande                                 | 29. <b>Cookbox</b><br>Caja de cocción<br>Boîtier de cuisson   |   |
| 15. <b>Knob Bezel</b><br>Moldura decorativa de la perilla<br>Plaque indicatrice du bouton             | 30. <b>Bulkhead</b><br>Tabique divisorio<br>Cloison   |   |



VISION ÉCLATÉE, DIAGRAMA DE DESPIECE

E/S 450\_NG\_US

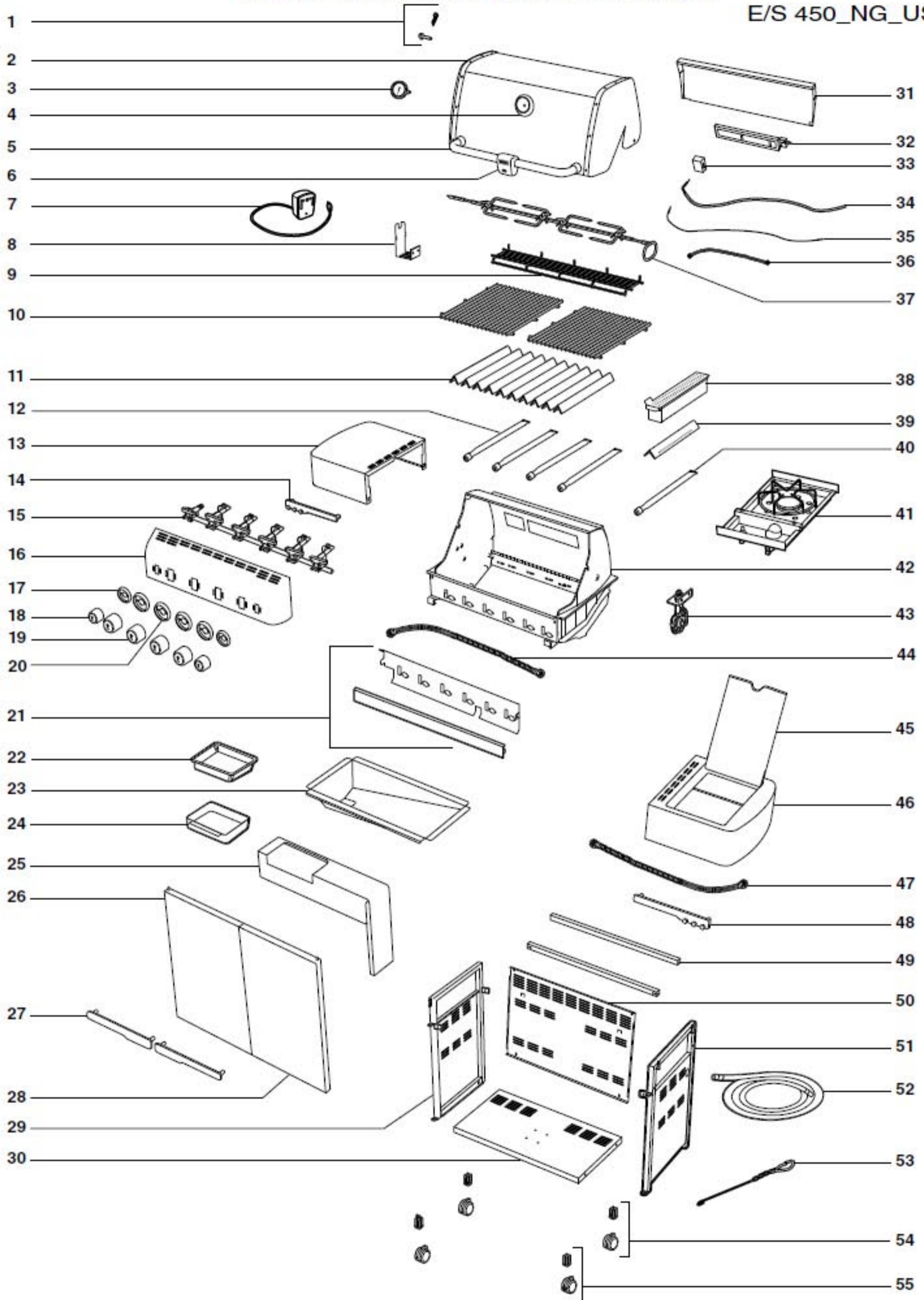



## LISTA DEL DIAGRAMA DE DESPIECE, LISTE DE LA VISION ÉCLATÉE

- |   |   |   |
|---|---|---|
| 1. <b>Shroud Hardware</b><br>Accesorios de la cubierta<br>Structure de protection                             | 20. <b>Large Knob Bezel</b><br>Moldura decorativa de la perilla grande<br>Plaque indicatrice du grand bouton                  | 38. <b>Smoker Box</b><br>Caja del ahumador<br>Boîtier du fumoir                             |
| 2. <b>Shroud</b><br>Cubierta<br>Tôle de protection  | 21. <b>Water Baffle / Heat Shield</b><br>Reflector de agua / Pantalla térmica<br>Protection contre l'eau/Cloison anti-chaleur | 39. <b>Smoker Bar</b><br>Barra del ahumador<br>Barre du fumoir                              |
| 3. <b>Thermometer</b><br>Termómetro<br>Thermomètre  | 22. <b>Disposable Drip Pan</b><br>Bandeja de goteo desechable<br>Egouttoir jetable  | 40. <b>Smoker Burner</b><br>Quemador del ahumador<br>Brûleur du fumoir                      |
| 4. <b>Thermometer Bezel</b><br>Moldura decorativa del termómetro<br>Plaque indicatrice du thermomètre         | 23. <b>Drip Tray</b><br>Bandeja de goteo<br>Plateau-égouttoir   | 41. <b>Side Burner</b><br>Quemador lateral<br>Brûleur latéral                               |
| 5. <b>Handle</b><br>Asa<br>Poignée  | 24. <b>Catch Pan</b><br>Plato recolector<br>Egouttoir   | 42. <b>Cookbox</b><br>Caja de cocción<br>Boîtier de cuisson                                 |
| 6. <b>Grill Out™ Handle Light</b><br>Luz de asa Grill Out™<br>Lampe de poignée Grill Out™                     | 25. <b>Catch Pan Holder</b><br>Soporte del plato recolector<br>Support d'égouttoir  | 43. <b>Bulkhead</b><br>Tabique divisorio<br>Cloison   |
| 7. <b>Rotisserie Motor</b><br>Motor del asador<br>Moteur de la rôtissoire                                     | 26. <b>Left Door</b><br>Puerta izquierda<br>Porte gauche  | 44. <b>Manifold Hose</b><br>Manguera del múltiple<br>Tuyau du collecteur                    |
| 8. <b>Rotisserie Bracket</b><br>Soporte del asador giratorio<br>Support de la rôtissoire                      | 27. <b>Door Handles</b><br>Asas de las puertas<br>Poignées de portes  | 45. <b>Side Burner Lid</b><br>Tapa del quemador lateral<br>Couvercle du brûleur latéral     |
| 9. <b>Warming Rack</b><br>Rejilla de calentamiento<br>Grille de réchauffage                                   | 28. <b>Right Door</b><br>Puerta derecha<br>Porte droite   | 46. <b>Side Burner Table</b><br>Mesa del quemador lateral<br>Tablette du brûleur latéral    |
| 10. <b>Cooking Grates</b><br>Parrillas de cocción<br>Grilles de cuisson                                       | 29. <b>Left Frame Panel</b><br>Panel izquierdo del bastidor<br>Panneau du cadre gauche  | 47. <b>Side Burner Hose</b><br>Manguera del quemador lateral<br>Tuyau du brûleur latéral    |
| 11. <b>Flavorizer® Bars</b><br>Barras Flavorizer®<br>Barres Flavorizer®                                       | 30. <b>Bottom Panel</b><br>Panel inferior<br>Panneau inférieur  | 48. <b>Right Tool Holder</b><br>Portaherramientas derecho<br>Support d'ustensiles de droite |
| 12. <b>Burner Tubes</b><br>Tubos quemadores<br>Tubes des brûleurs   | 31. <b>IR Burner Cover</b><br>Tapa del quemador IR<br>Cache du brûleur IR   | 49. <b>Frame Support</b><br>Soporte del bastidor<br>Support du cadre                        |
| 13. <b>Side Table</b><br>Mesa lateral<br>Tablette latérale  | 32. <b>Infrared Burner</b><br>Quemador infrarrojo<br>Brûleur à infrarouge   | 50. <b>Back Panel</b><br>Panel trasero<br>Panneau arrière                                   |
| 14. <b>Left Tool Holder</b><br>Portaherramientas izquierdo<br>Support d'ustensiles de gauche                  | 33. <b>IR Burner Box</b><br>Caja del quemador infrarrojo<br>Boîtier du brûleur IR   | 51. <b>Right Frame Panel</b><br>Panel derecho del bastidor<br>Panneau du cadre droit        |
| 15. <b>Manifold</b><br>Múltiple<br>Collecteur   | 34. <b>IR Burner Igniter Wire</b><br>Cable de encendido del quemador IR<br>Câble de l'allumeur du brûleur IR                  | 52. <b>Natural Gas Hose</b><br>Manguera del gas natural<br>Tuyau de gaz naturel             |
| 16. <b>Control Panel</b><br>Tablero de control<br>Panneau de commandes  | 35. <b>Thermocouple</b><br>Termopar<br>Thermocouple   | 53. <b>Matchstick Holder</b><br>Portacerillos<br>Porte-allumette                            |
| 17. <b>Small Knob Bezel</b><br>Moldura decorativa de la perilla pequeña<br>Plaque indicatrice du petit bouton | 36. <b>IR Burner Hose</b><br>Manguera del quemador IR<br>Tuyau du brûleur IR  | 54. <b>Caster</b><br>Rueda giratoria<br>Roulette  |
| 18. <b>Small Knob</b><br>Perilla pequeña<br>Petit bouton  | 37. <b>Rotisserie Spit Assembly</b><br>Ensamble del espetón del asador giratorio<br>Ensemble de la broche de la rôtissoire    | 55. <b>Locking Caster</b><br>Rueda giratoria con bloqueo<br>Roulette autobloquante          |
| 19. <b>Large Knob</b><br>Perilla grande<br>Grand bouton   |   |   |



- Adjust doors, if necessary
- Si fuese necesario, ajuste la puerta
- Ajustez la porte si nécessaire

**1**

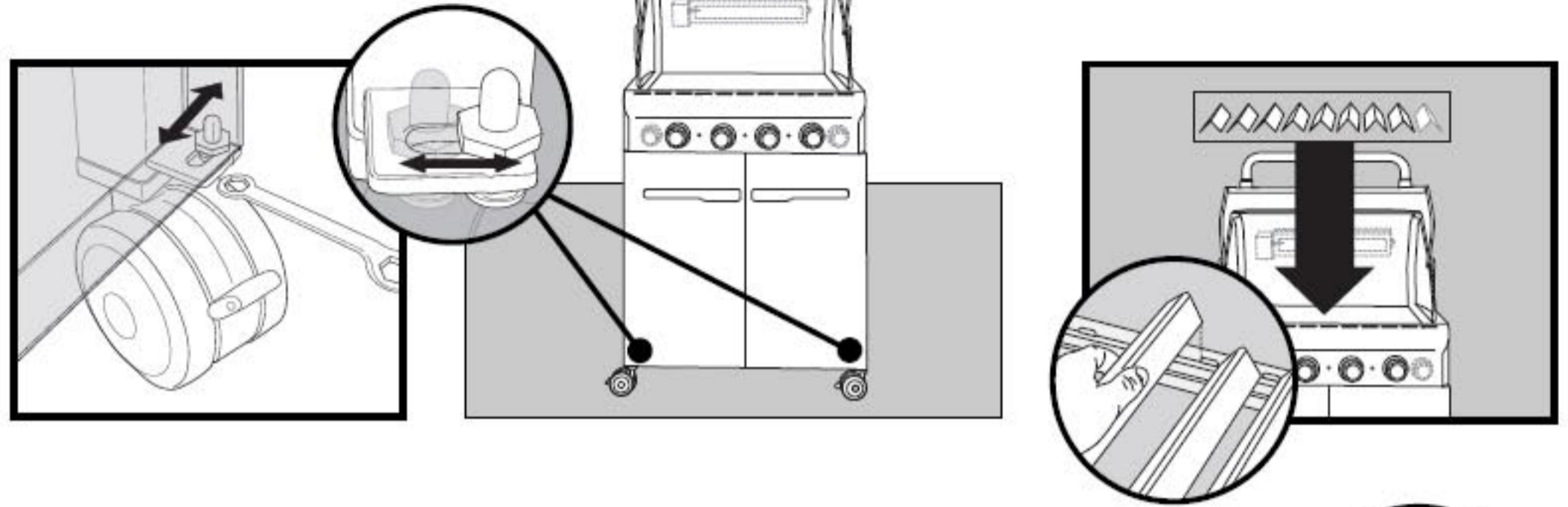

**2**

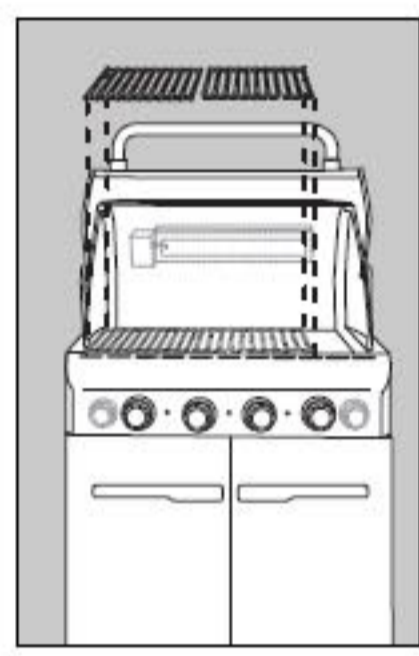

**3**

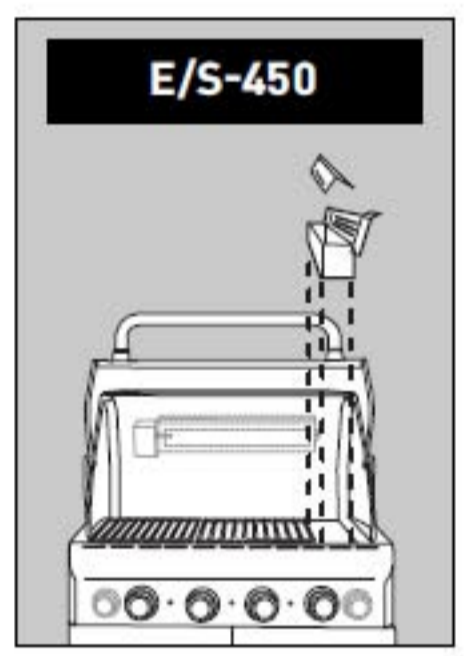
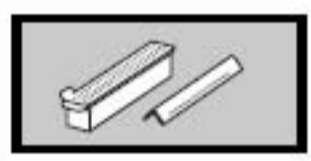

**4**

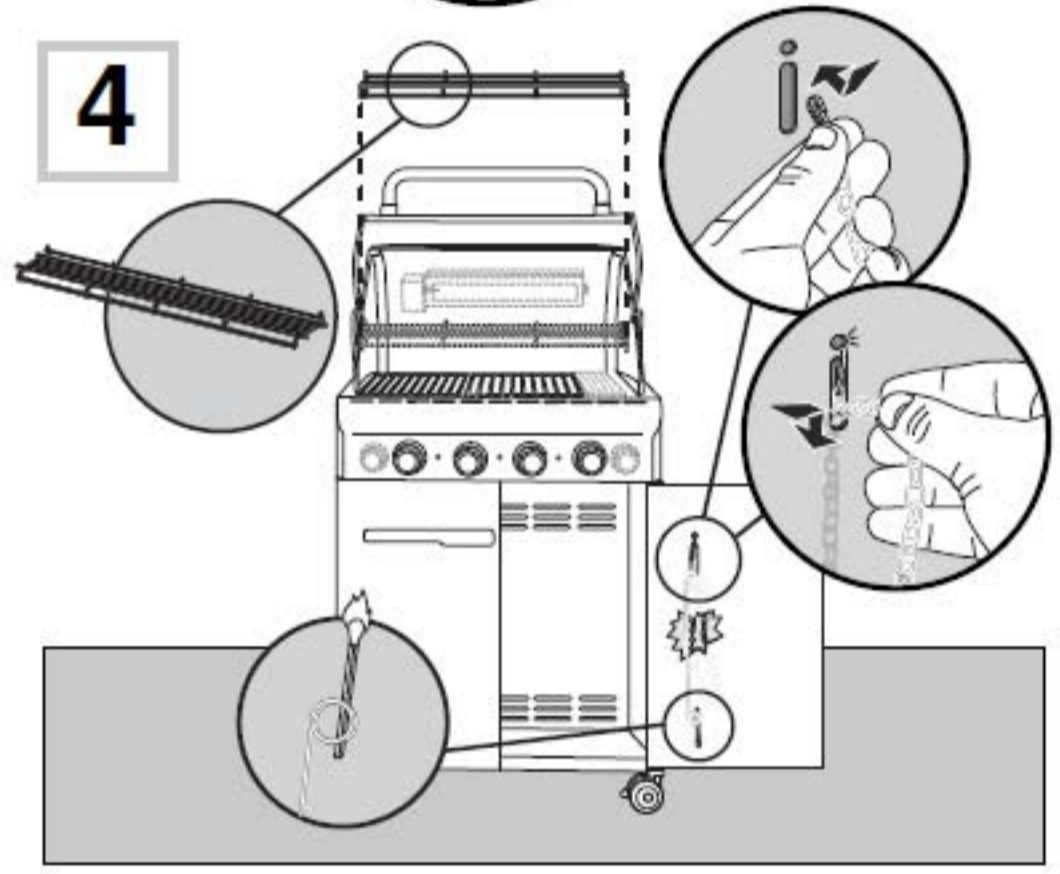

**5**

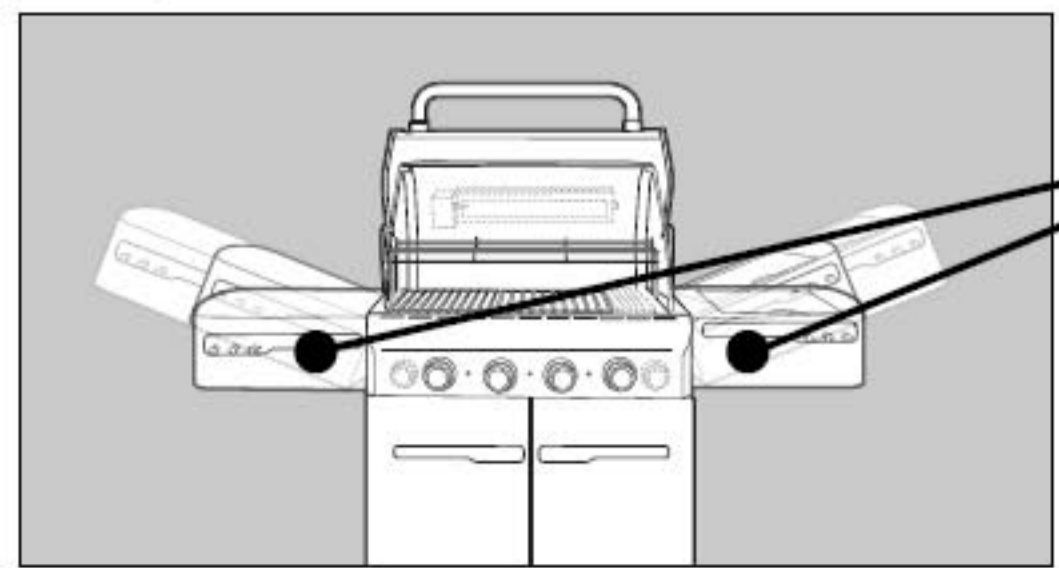



6

3 -



3 -

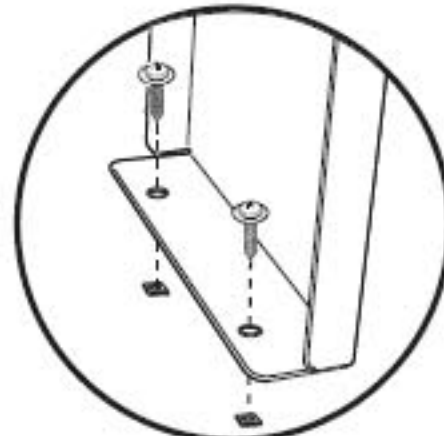
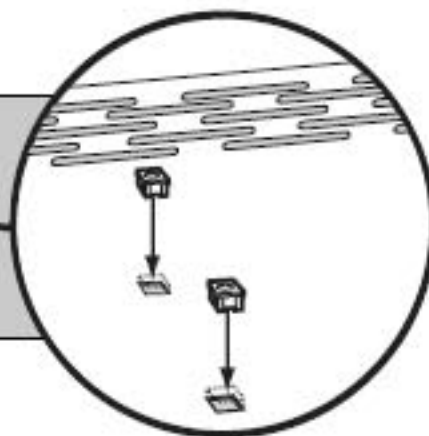
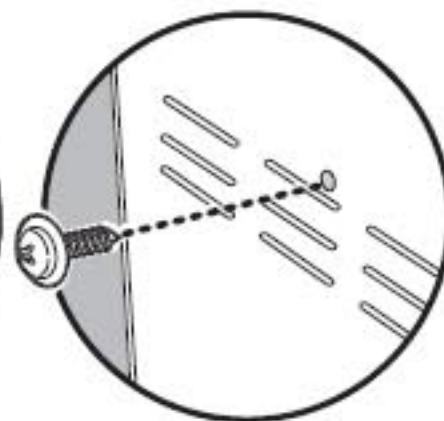
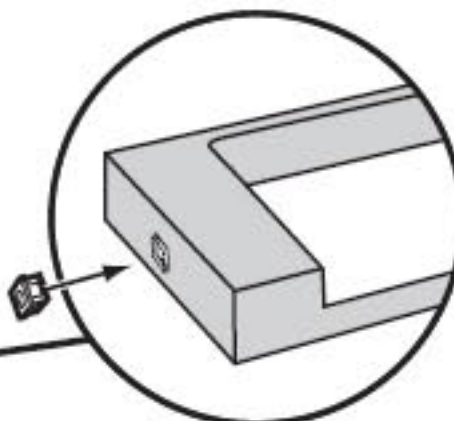
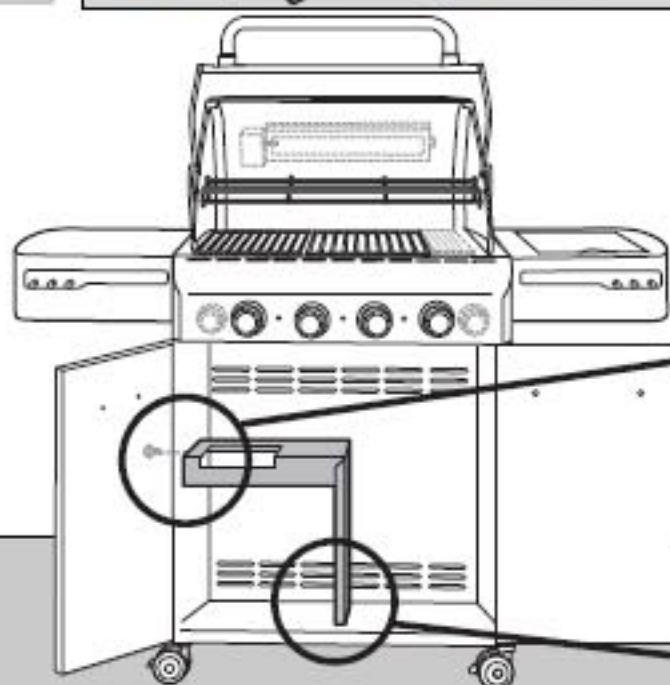

7

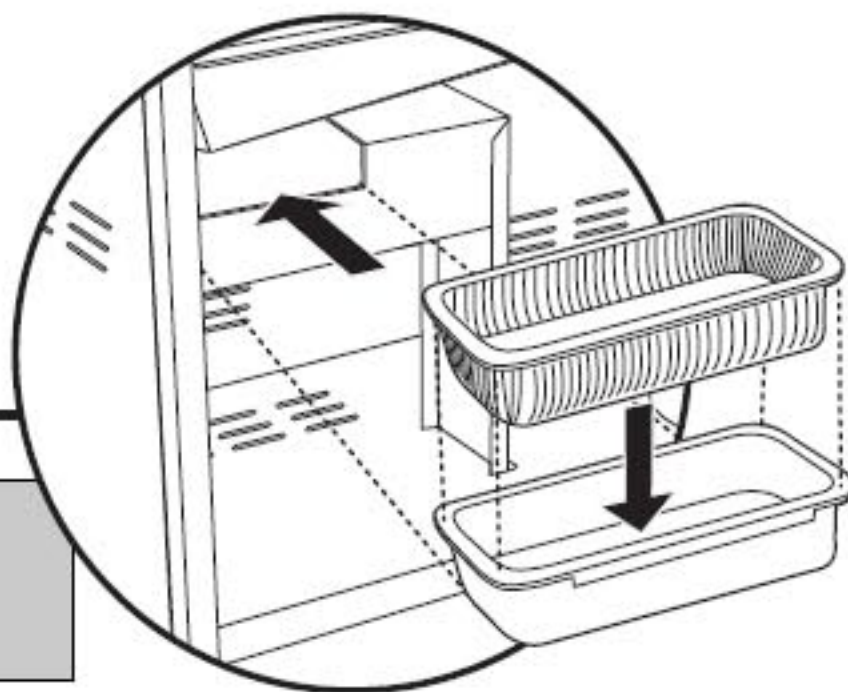
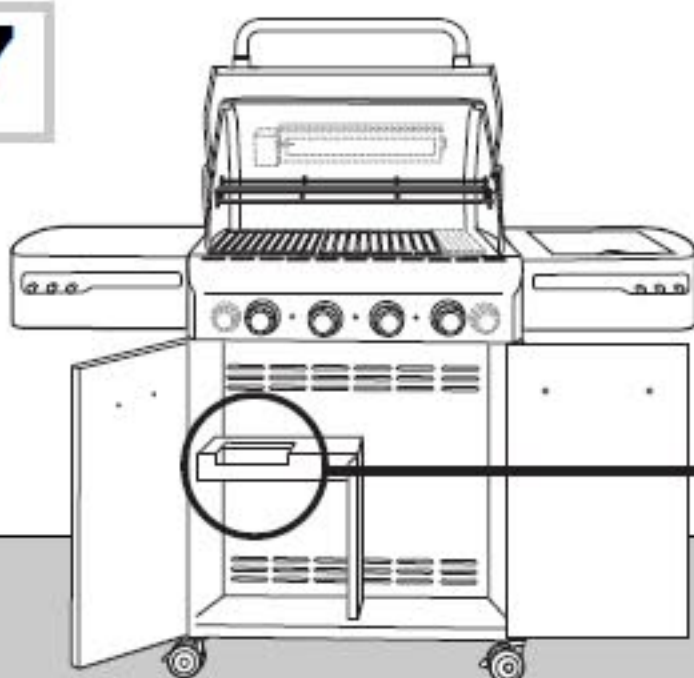

8

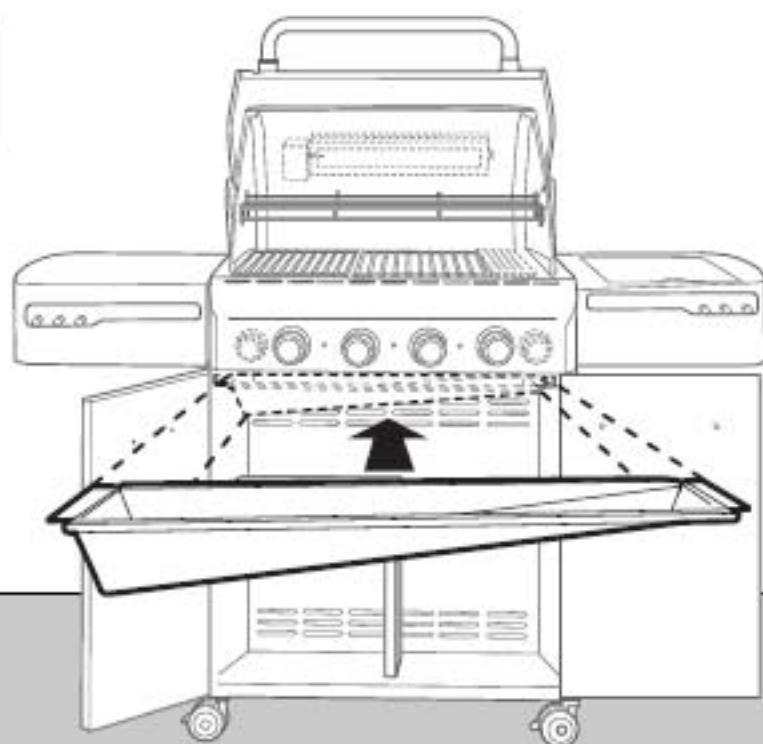



9

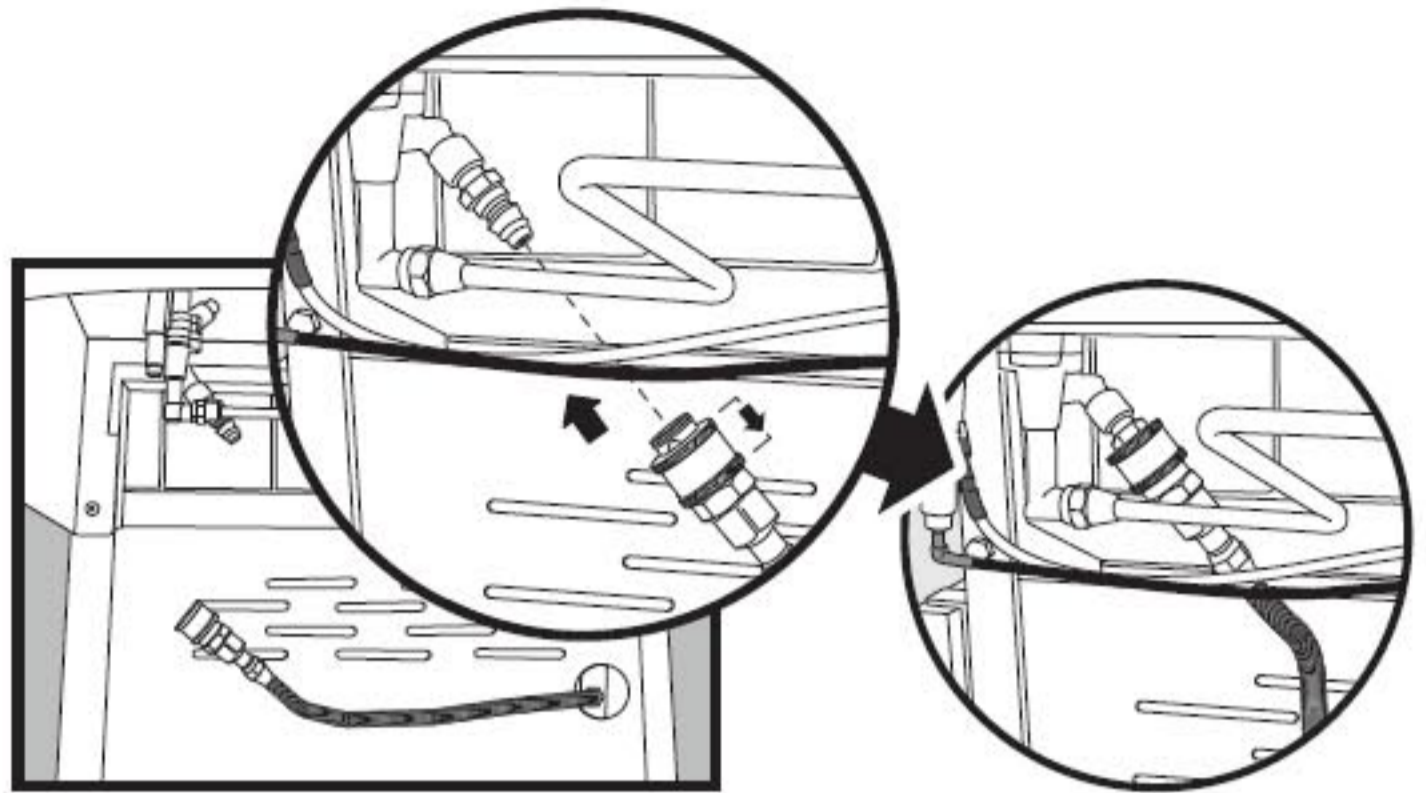
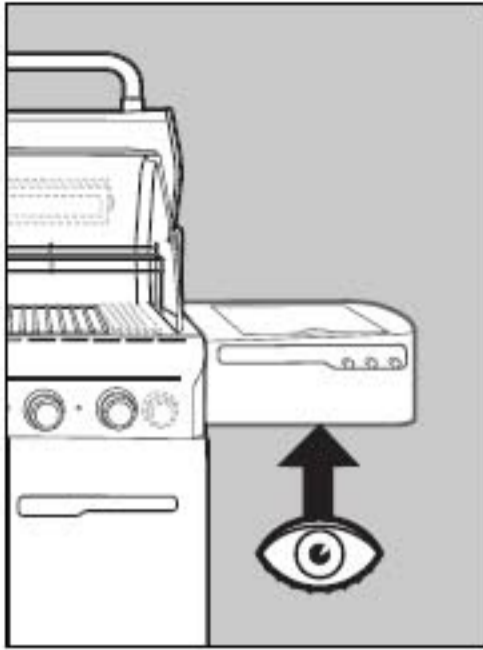

10

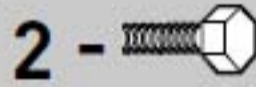

E/S-450

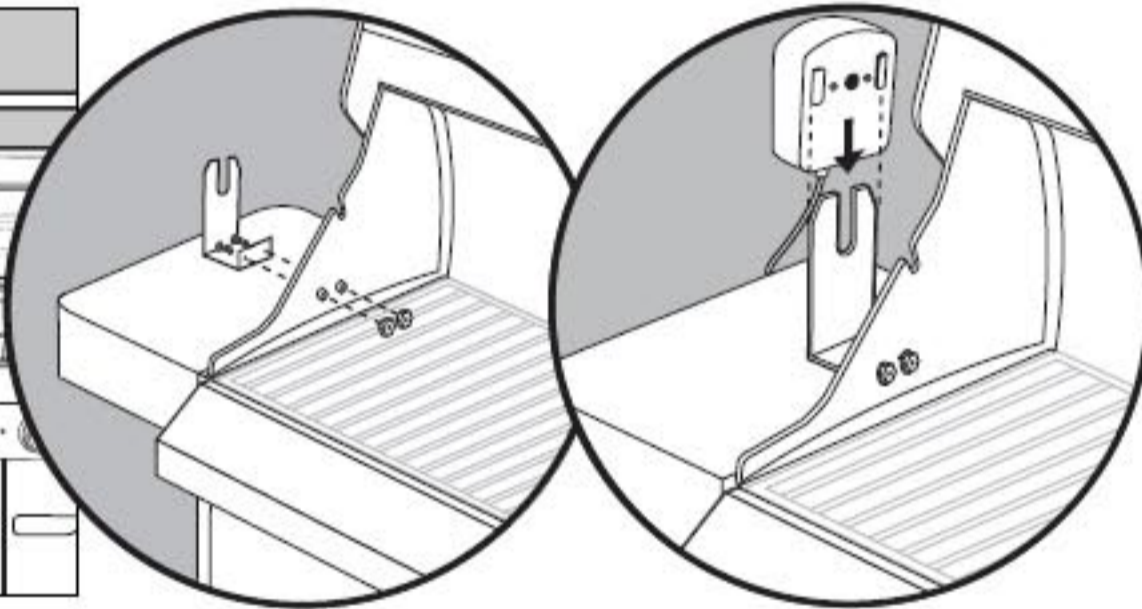
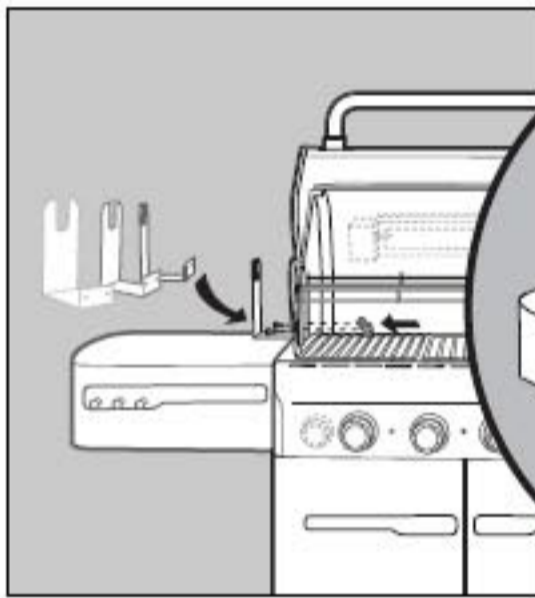

11

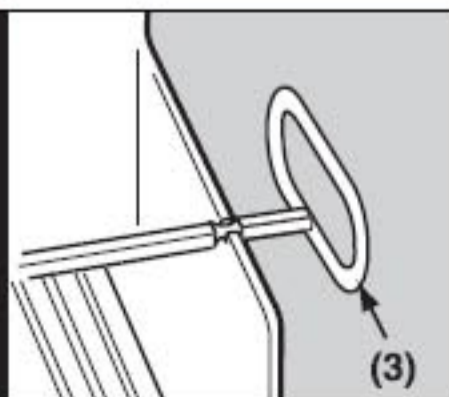
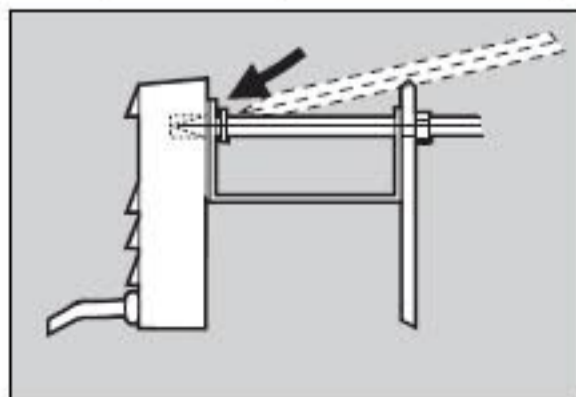
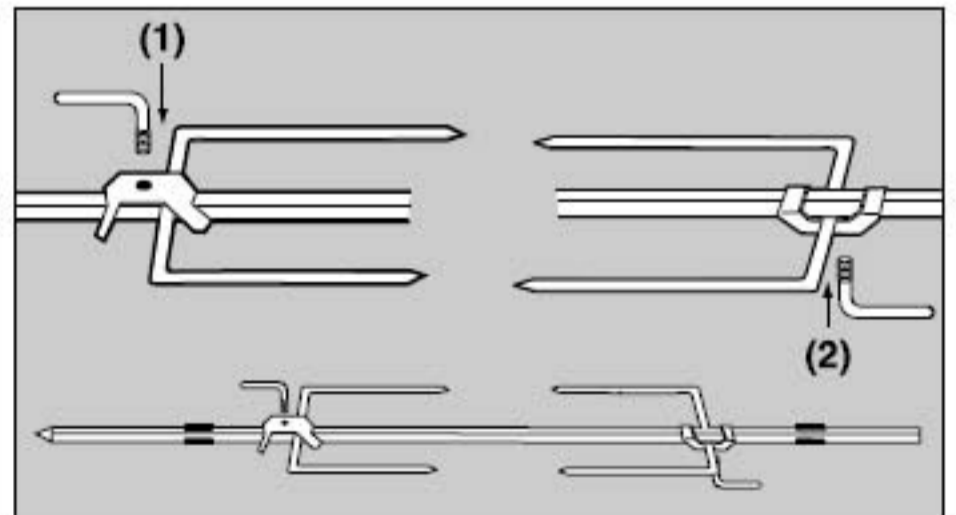
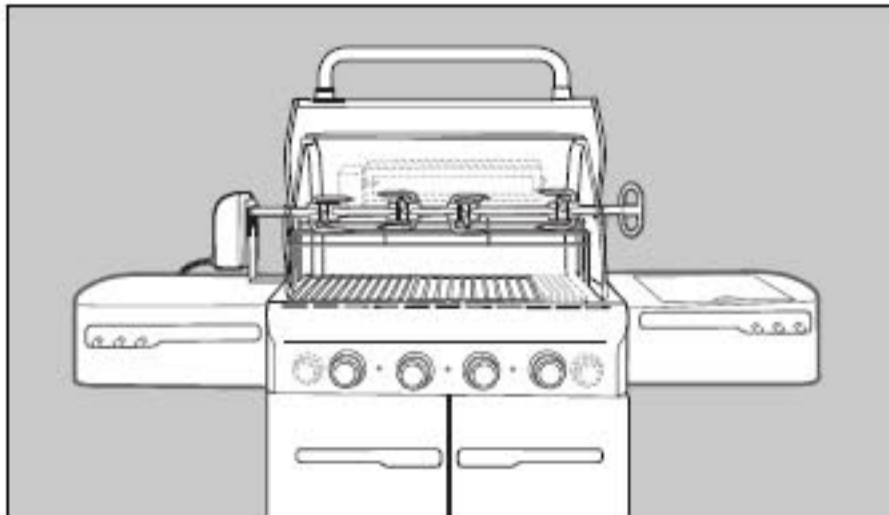



12

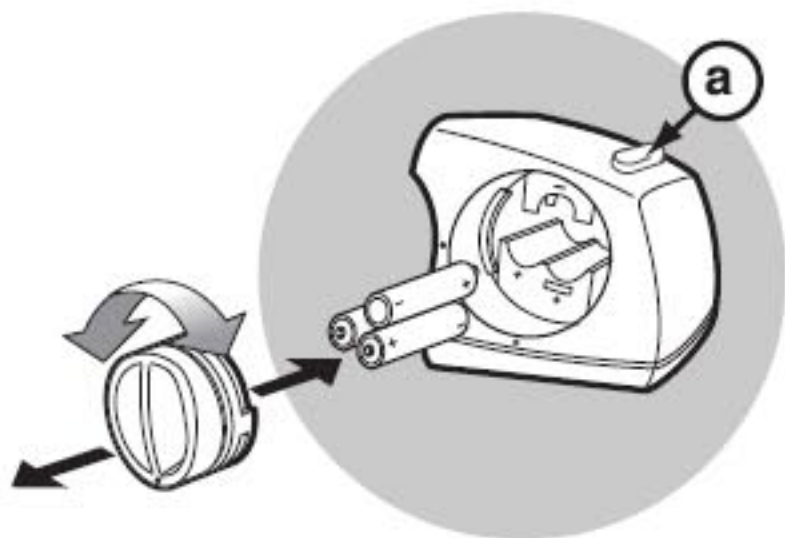
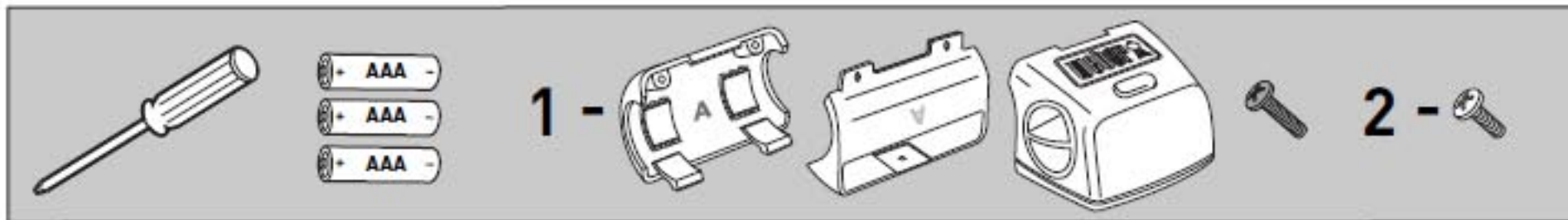

The Weber Grill Out™ Handle Light has a "Tilt Sensor": Lid up - ON / Lid Closed - OFF. The power button (a) activates or deactivates the "Tilt Sensor." For daytime use, deactivate the sensor by pressing power button (a).

La Lámpara de Asa Weber Grill Out™ tiene un "sensor de inclinación": tapa abierta - ENCENDIDA / tapa cerrada - APAGADA. El botón de encendido (a) activa o desactiva al "sensor de inclinación". Para uso durante el día, desactive al sensor pulsando el botón de encendido (a).

La Lampe de poignée Weber Grill Out™ est pourvu d'un "Décteur Tilt" : Couvercle relevé - MARCHÉ / Couvercle fermé - ARRET (OFF). Le bouton d'alimentation électrique (a) active ou désactive le "Décteur Tilt." Pour une utilisation pendant la journée, veuillez désactiver le détecteur en appuyant sur le bouton d'alimentation électrique (a).

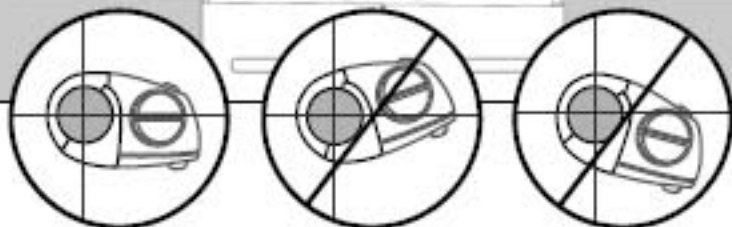
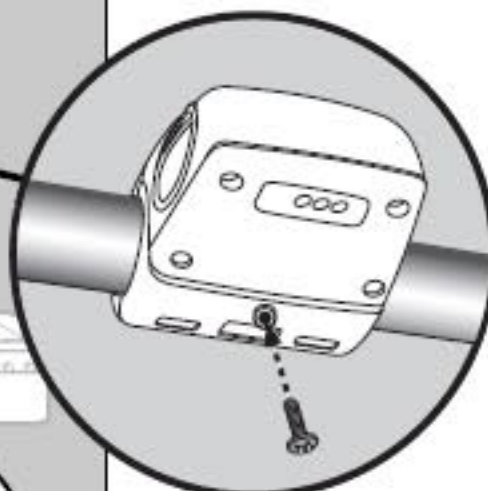
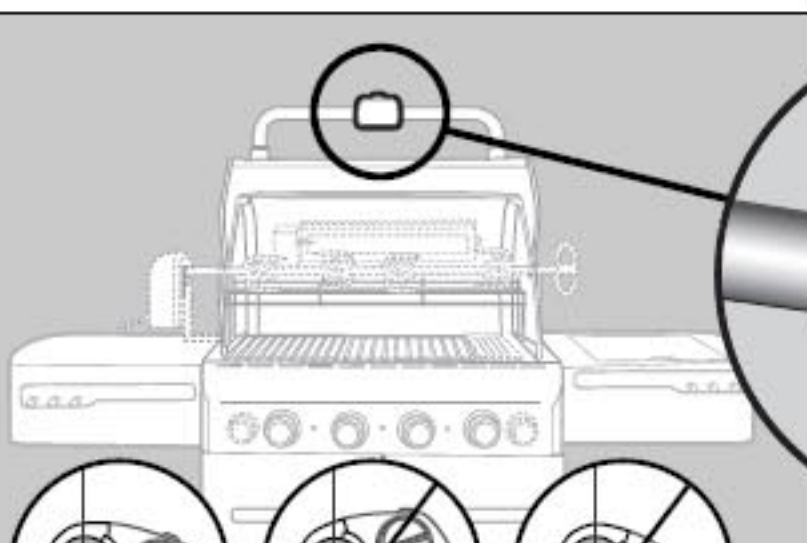
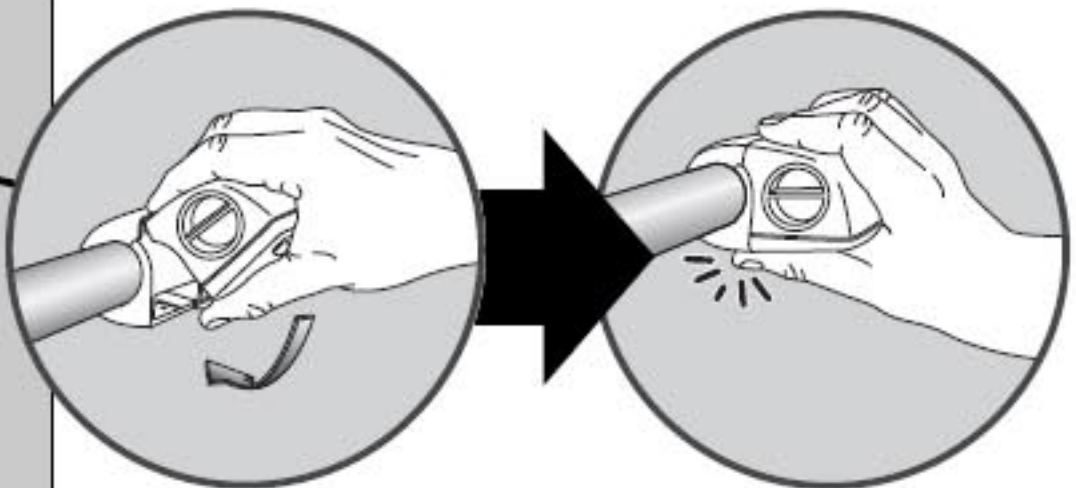
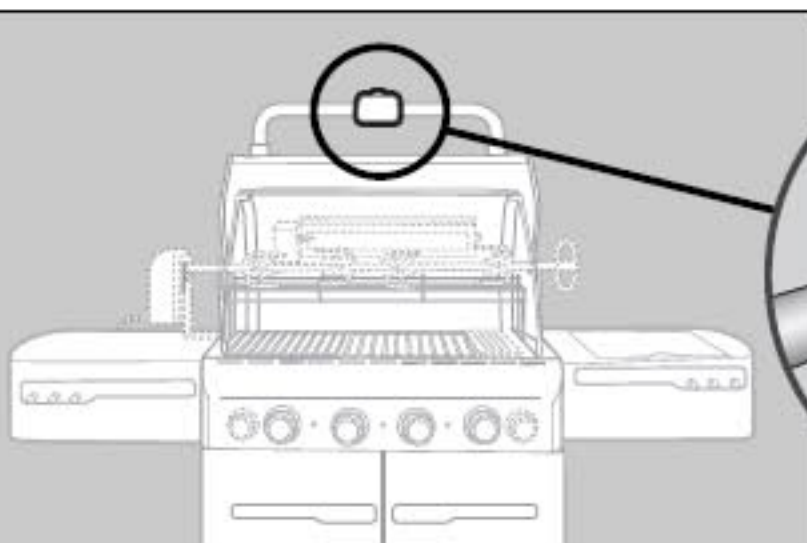
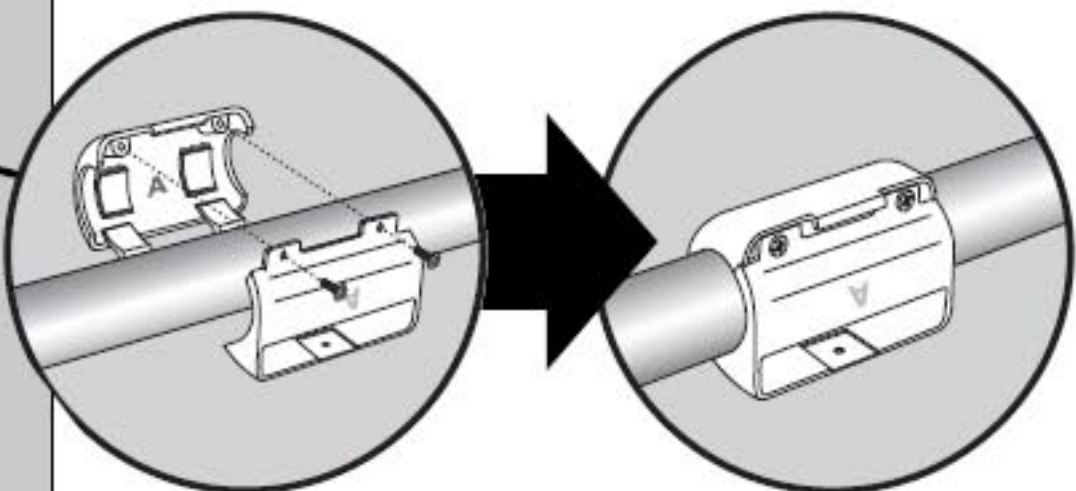
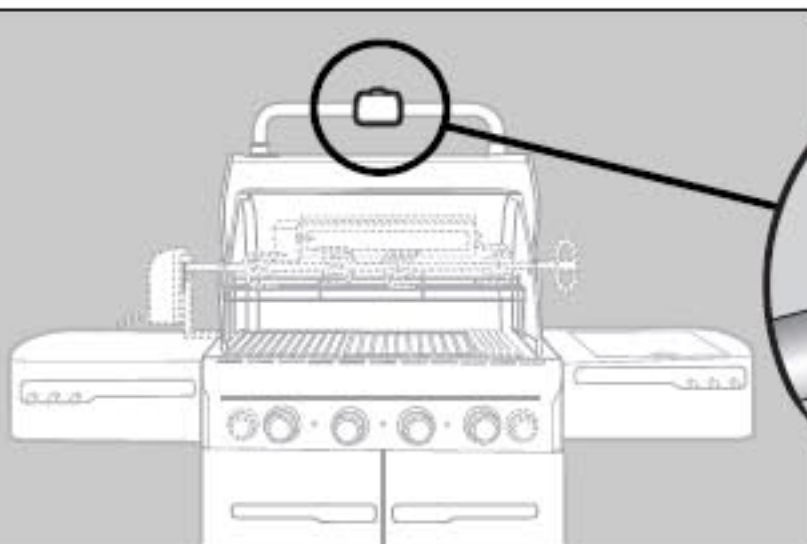



Your Weber® gas barbecue is a portable outdoor cooking appliance. With the Weber® gas barbecue you can grill, barbecue, roast and bake with results that are difficult to duplicate with indoor kitchen appliances. The closed lid and Flavorizer® bars produce that "outdoor" flavor in the food.

The Weber® gas barbecue is portable so you can easily change its location in your yard or on your patio. Portability means you can take your Weber® gas barbecue with you if you move.

The natural gas supply is easy to use and gives you more cooking control than charcoal fuel.

- These instructions will give you the minimum requirements for assembling your Weber® gas barbecue. Please read the instructions carefully before using your Weber® gas barbecue. Improper assembly can be dangerous.
- Not for use by children.
- If there are local codes that apply to portable gas grills, you will have to conform to them. Installation must conform with local codes or, in the absence of local codes, with either the National Fuel Gas Code, ANSI Z223.1/NFPA 54, Natural Gas and Propane Installation Code, CSA B149.1, or Propane Storage and Handling Code, B149.2, or the Standard for Recreational Vehicles, ANSI A 119.2/NFPA 1192, and CSA Z240 RV Series, Recreational Vehicle Code, as applicable.
- This Weber® gas barbecue is designed for natural (piped in city) gas only. Do not use liquid propane (LP) bottled gas. The valves, orifices and hose are for natural gas only.
- Do not use with charcoal fuel.
- Check that the area under the control panel and the bottom tray are free from debris that might obstruct the flow of combustion or ventilation air.

## FOR INSTALLATION IN CANADA

These instructions, while generally acceptable, do not necessarily comply with the Canadian Installation codes, particularly with piping above and below ground. In Canada the installation of this appliance must comply with local codes and/or Standards CAN/CGA-B149.1 (Installation Code for Natural Gas Burning Appliances and Equipment).

## STORAGE

- The gas must be turned off at the natural gas supply when the Weber® gas barbecue is not in use.
- When the Weber® gas barbecue is stored indoors, the gas supply must be disconnected.
- The Weber® gas barbecue should be checked for gas leaks and any obstructions in the burner tubes before using. (See Section: "Maintenance/Annual Maintenance").
- Check that the areas under the control panel and the slide out bottom tray are free from debris that might obstruct the flow of combustion or ventilation air.
- The Spider /Insect Screens should also be checked for any obstructions. (See Section: "Maintenance/Annual Maintenance").

## GRILLING METHODS

*Note: If grill loses heat while cooking refer to the troubleshooting section of this manual.*

**⚠ WARNING: Do not move the Weber® gas barbecue when operating or while barbecue is hot.**

You can adjust the individual main burners as desired. The control settings are **START/ HI, MEDIUM, LOW, or OFF.**

*Note: The temperature inside your cooking box for the first few uses, while surfaces are still very reflective, may be hotter than those shown in your cookbook. Cooking conditions, such as wind and weather, may require the adjustment of the burner controls to obtain the correct cooking temperatures.*

**If burners go out during cooking, open lid, turn off all burners and wait five minutes before relighting.**

**Preheating** - Your Weber® gas barbecue is an energy-efficient appliance. It operates at an economical low BTU rate. To preheat: after lighting, close lid and turn all burners to "START/HI". Preheating to between 500° and 550° F (260° and 290° C) will take 10 to 15 minutes depending on conditions such as air temperature and wind.

**Drippings and grease** - The Flavorizer® bars are designed to "smoke" the correct amount of drippings for flavorful cooking. Excess drippings and grease will accumulate in the catch pan under the slide out bottom tray. Disposable foil drip pans are available that fit the catch pan.

## OPERATING

- ⚠ **WARNING: Only use this barbecue outdoors in a well-ventilated area. Do not use in a garage, building, breezeway or any other enclosed area.**
- ⚠ **WARNING: Your Weber® gas barbecue shall not be used under overhead combustible construction.**
- ⚠ **WARNING: Your Weber® gas barbecue is not intended to be installed in or on recreational vehicles and/or boats.**
- ⚠ **WARNING: Do not use the barbecue within 24 inches of combustible materials. This includes the top, bottom, back or sides of the grill.**
- ⚠ **WARNING: The entire cooking box gets hot when in use. Do not leave unattended.**
- ⚠ **WARNING: Keep any electrical supply cord and the fuel supply hose away from any heated surface.**
- ⚠ **WARNING: Keep the cooking area clear of flammable vapors and liquids, such as gasoline, alcohol, etc., and combustible materials.**

## GAS SUPPLY TESTING

- Disconnect your Weber® gas barbecue when the gas supply is being tested at high pressures. This appliance and its individual shutoff valve must be disconnected from the gas supply piping system during any pressure testing of that system at test pressures in excess of 1/2 psig (3.5 kPa).
- Turn off your Weber® gas barbecue when the gas supply is being tested at low pressures. This appliance must be isolated from the gas supply piping system by closing its individual manual shutoff valve during any pressure testing of the gas supply piping system at the pressure equal to or less than 1/2 psig (3.5 kPa).

**⚠ WARNING: Check the bottom tray for grease build-up before each use. Remove excess grease to avoid a grease fire in the slide out bottom tray.**

## CLEANING

- ⚠ **WARNING: Turn your Weber® gas barbecue off and wait for it to cool before cleaning.**
- ⚠ **CAUTION: Do not clean your Flavorizer® bars or cooking grates in a self-cleaning oven.**

For availability of replacement cooking grates and Flavorizer® bars contact the Customer Service Representative in your area using the contact information on our website. Log onto [www.weber.com](http://www.weber.com)

**Outside surfaces** - Use a warm soapy water solution to clean, then rinse with water.

**⚠ CAUTION: Do not use oven cleaner, abrasive cleansers (kitchen cleansers), cleaners that contain citrus products, or abrasive cleaning pads on barbecue or cart surfaces.**



**Slide out Bottom tray** - Remove excess grease, then wash with warm soapy water, then rinse.

**Flavorizer® bars and Cooking grates** - Clean with a suitable brass bristle brush. As needed, remove from grill and wash with warm soapy water, then rinse with water.

**Catch pan** - Disposable foil trays are available, or you can line the catch pan with aluminum foil. To clean the catch pan, wash with warm soapy water, then rinse.

**Thermometer** - Wipe with warm soapy water; clean with plastic scrub ball.

**Inside cooking module** - Brush any debris off of burner tubes. **DO NOT ENLARGE BURNER PORTS (OPENINGS)**. Wash inside of cooking box with warm soapy water and a water rinse.

**Inside Lid** - While lid is warm, wipe inside with paper towel to prevent grease build-up. Flaking built-up grease resembles paint flakes.

**Stainless steel surfaces** - Wash with a soft cloth and a soap and water solution. Be careful to scrub with the grain direction of the stainless steel.

Do not use cleaners that contain acid, mineral spirits or xylene. Rinse well after cleaning.

**Preserve Your Stainless Steel** - Your grill or its cabinet, lid, control panel and shelves may be made from stainless steel. To keep the stainless steel looking its best is a simple matter. Clean it with soap and water, rinse with clear water and wipe dry. For stubborn particles, the use of a non-metallic brush can be used.

**△ IMPORTANT:** Do not use a wire brush or abrasive cleaners on the stainless steel surfaces of your grill as this will cause scratches.

**△ IMPORTANT:** When cleaning surfaces be sure to rub/wipe in the direction of the grain to preserve the look of your stainless steel.

## GAS INSTRUCTIONS

### INSTALL GAS SUPPLY

#### GENERAL SPECIFICATIONS FOR PIPING

**Note:** Contact your local municipality for building codes regulating outdoor gas barbecue installations. In absence of Local Codes, you must conform to the latest edition of the National Fuel Gas Code: ANSI Z 223.1/NFPA 54, or CAN/CGA-B149.1, Natural Gas and Propane Installation Code. **WE RECOMMEND THAT THIS INSTALLATION BE DONE BY A PROFESSIONAL.**

Some of the following are general requirements taken from the latest edition of the National Fuel Gas Code: ANSI Z 223.1/NFPA 54, or CAN/CGA-B149.1, Natural Gas and Propane Installation Code for complete specifications.

- This barbecue is designed to operate at 4.5 inches of water column pressure (.163 psi).
- A manual shut-off valve must be installed outdoors, immediately ahead of the quick disconnect.
- An additional manual shut-off valve indoors should be installed in the branch fuel line in an accessible location near the supply line.
- The quick disconnect connects to a 1/2 inch NPT thread from the gas source. The quick disconnect fitting is a hand-operated device that automatically shuts off the flow of gas from the source when the barbecue is disconnected.
- The quick disconnect fitting can be installed horizontally, or pointing downward. Installing the fitting with the open end pointing upward can result in collecting water and debris.
- The dust covers (supplied plastic plugs) help keep the open ends of the quick disconnect fitting clean while disconnected.
- Pipe compound should be used which is resistant to the action of natural gas when connections are made.
- The outdoor connector must be firmly attached to rigid, permanent construction.

**△ WARNING:** Do not route the 10 foot hose under a deck. The hose must be visible.

#### GAS LINE PIPING

- If the length of the line required does not exceed 50 feet, use a 5/8" O.D. tube. One size larger should be used for lengths greater than 50 feet.
- Gas piping may be copper tubing, type K or L; polyethylene plastic tube, with a minimum wall thickness of .062 inch; or standard weight (schedule 40) steel or wrought iron pipe.
- Copper tubing must be tin-lined if the gas contains more than 0.3 grams of hydrogen sulfide per 100 cubic feet of gas.
- Plastic tubing is suitable only for outdoor, underground use.
- Gas piping in contact with earth, or any other material which may corrode the piping, must be protected against corrosion in an approved manner.
- Underground piping must have a minimum of 18" cover.

#### TEST CONNECTIONS

All connections and joints must be thoroughly tested for leaks in accordance with local codes and all listed procedures in the latest edition of the National Fuel Gas Code: ANSI Z 223.1/NFPA 54, or CAN/CGA-B149.1

#### △ DANGER

Do not use an open flame to check for gas leaks. Be sure there are no sparks or open flames in the area while you check for gas leaks. This will result in a fire or explosion which can cause serious bodily injury or death and damage to property.

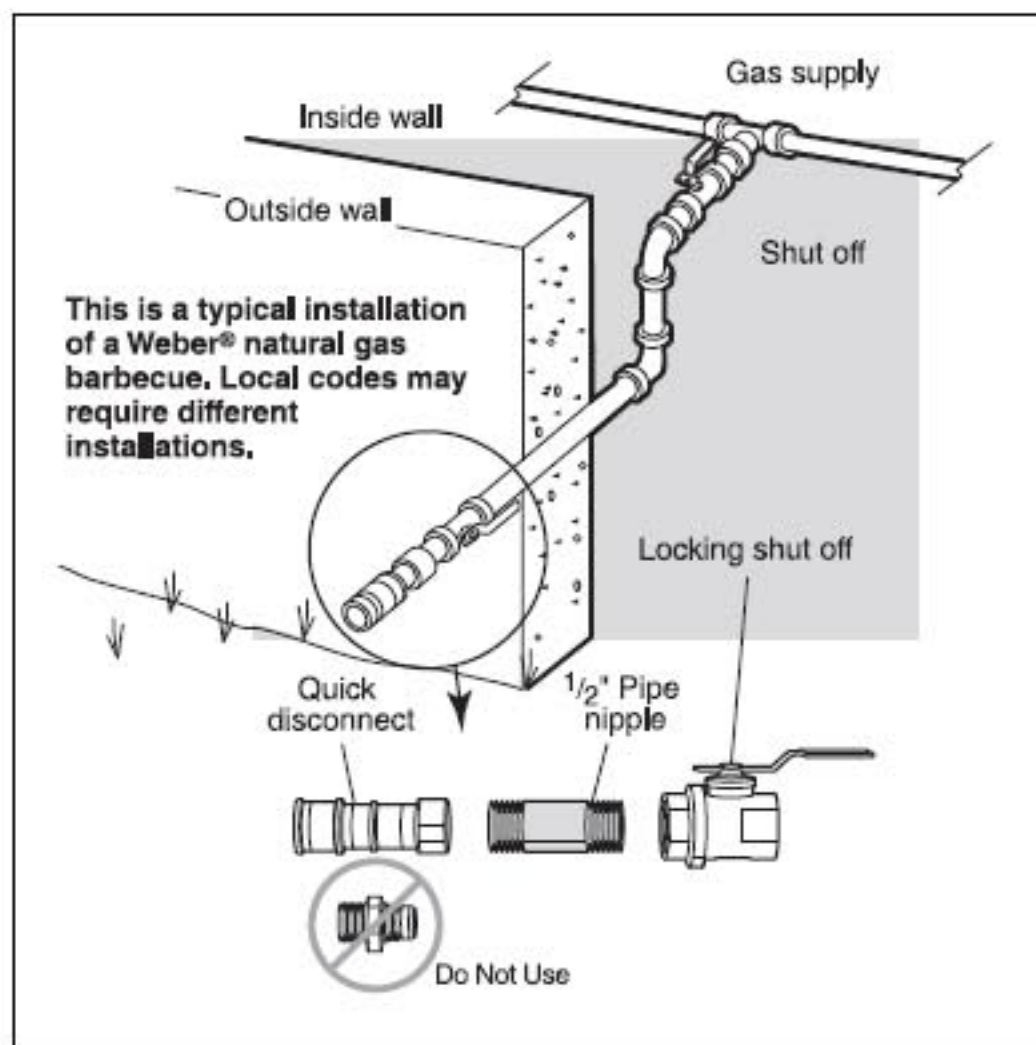



## TYPE OF GAS

Your natural gas grill is factory built to operate using natural gas only. Never attempt to operate your grill on gases other than the type specified on the grill rating plates. Your grill operates at 4.5" of water column pressure. If replacement of the hose becomes necessary, factory specified parts are required. See your local dealer. For safety and design reasons, the conversion of a Weber® grill from operation using Natural gas to operation using LP gas requires the change out of the entire gas supply system of the grill. If this becomes necessary, see your dealer for additional information.

## WHAT IS NATURAL GAS?

Natural gas, often called methane, is a safe modern fuel. Natural gas is supplied by your local utility and should be readily available if your house is already heated with gas.

## PORTABLE INSTALLATION

Weber® recommends moving the grill at least two (2) feet from the gas supply and any combustible surfaces. After the gas supply has been run and checked for leaks in accordance to the assembly instructions, you are ready to grill. To connect the hose to the gas supply, pull back the outer fitting, insert the hose fitting all of the way, and release the outer fitting. This process will produce a gas joint.

## LEAK CHECK PREPARATION

### CHECK THAT ALL BURNER VALVES ARE OFF

Valves are shipped in the "OFF" position, but you should check to be sure that they are turned off. Check by pushing in and turning clockwise. If they do not turn, they are off. Proceed to the next step. If they do turn continue turning them clockwise until they stop, then they are off. Proceed to the next step.

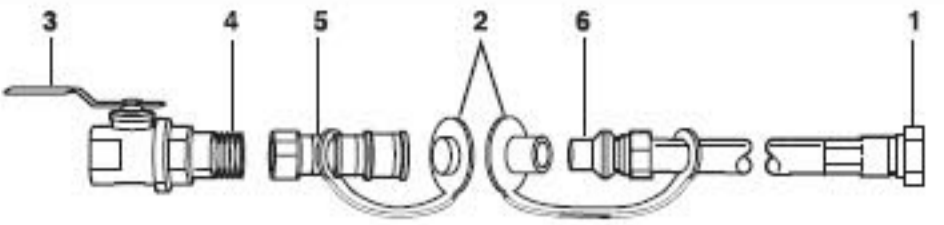

1	Swivel Connection
2	Install covers when hose is disconnected
3	Shut Off Valve
4	Coat this pipe nipple with gas resistant pipe dope
5	Socket
6	Male Connection

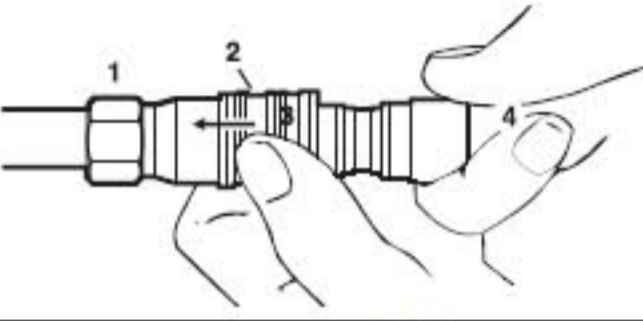
1	Socket
2	Sleeve
3	Push Sleeve Back
4	Plug

Push plug until sleeve snaps forward locking plug in socket.  
(This turns on gas automatically.)  
When properly assembled the plug cannot be removed without pushing the sleeve back.  
To disconnect, push sleeve back and pull out plug.  
(This automatically shuts off gas.)

## CHECK FOR GAS LEAKS

**⚠ WARNING:** The gas connections of your Summit® gas grill have been factory tested. We do however recommend that you leak check all gas connections before operating your Summit® gas grill.

## REMOVE CONTROL PANEL

Tool required: Phillips Screwdriver.

- 1) Remove the burner control knobs.
- 2) Remove the two screws that secure the control panel to the frame.

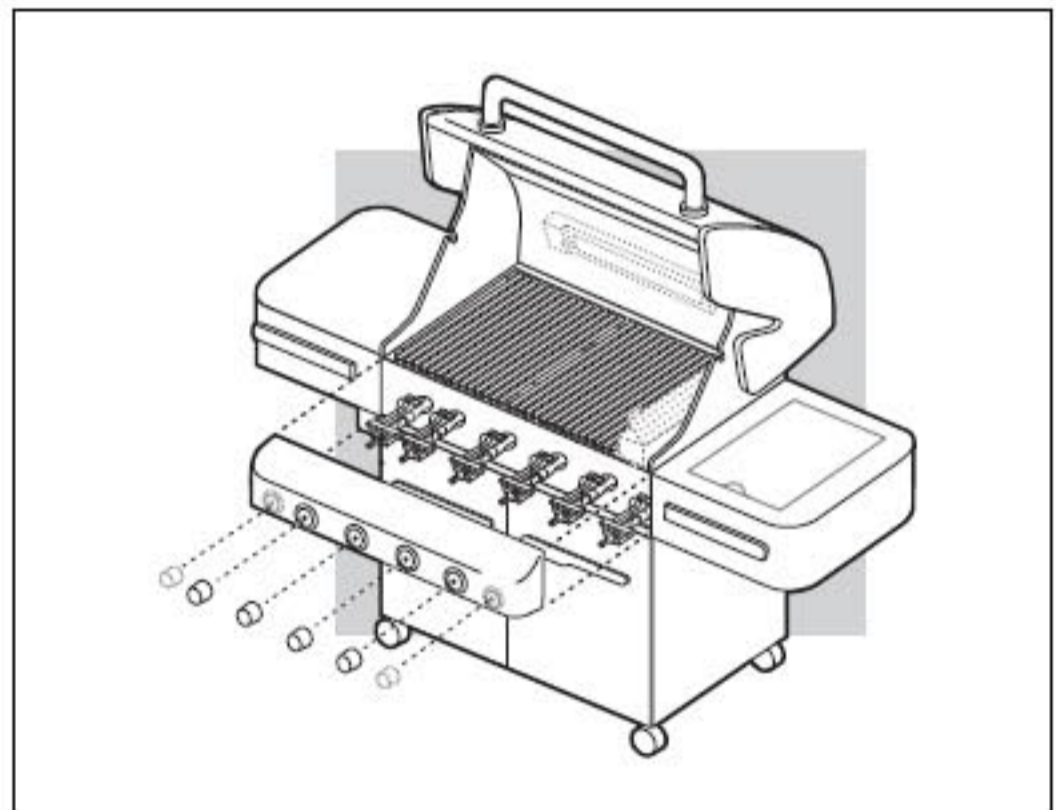



- 3) Remove the control panel. Tilt panel forward and lift up and away from grill.

Completely remove the control panel (3) from the cooking box assembly exposing the valves, burners, igniter, and manifold.

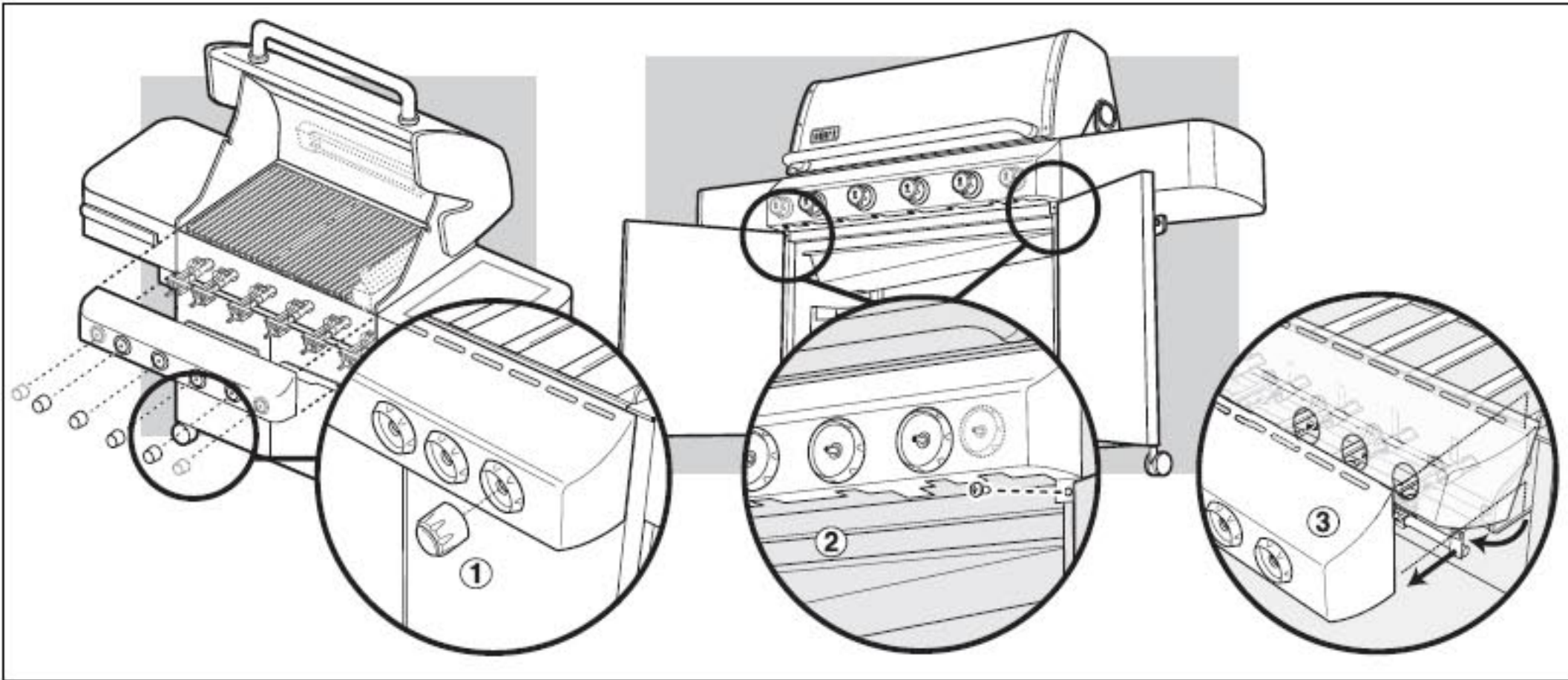

### CHECK THE FLEXIBLE HOSE TO MANIFOLD CONNECTION

The natural gas hose has been attached during the manufacturing process. We do recommend that the hose to gas manifold connection be leak tested, following guidelines in this Owner's Guide, prior to barbecue operation.

### CHECK FOR GAS LEAKS

#### ⚠ DANGER

Do not use an open flame to check for gas leaks. Be sure there are no sparks or open flames in the area while you check for leaks. Sparks or open flames will result in a fire or explosion which can cause serious bodily injury or death and damage to property.

- ⚠ **WARNING:** You should check for gas leaks every time you disconnect and reconnect a gas fitting.

*Note: All factory-made connections have been thoroughly checked for gas leaks. The burners have been flame-tested. As a safety precaution however, you should recheck all fittings for leaks before using your Weber® gas barbecue. Shipping and handling may loosen or damage a gas fitting.*

- ⚠ **WARNING:** Perform these leak checks even if your barbecue was dealer or store assembled.

You will need: a soap and water solution, and a rag or brush to apply it.

Make sure side burner is off (See LEAK CHECK PREPARATION). Remove valve control knob and screws. Remove porcelain top.

To perform leak checks: Slide back the collar of the quick disconnect (1). Push male fitting of the hose into the quick disconnect, and maintain pressure. Slide the collar closed (2). If it does not engage or lock, repeat procedure. Gas will not flow unless the quick disconnect is properly engaged.

Turn on gas supply.

Check for leaks by wetting the connections with the soap and water solution and watching for bubbles. If bubbles form or if a bubble grows, there is a leak.

*Note: Since some leak test solutions, including soap and water, may be slightly corrosive, all connections should be rinsed with water after checking for leaks.*

- ⚠ **WARNING:** Do not ignite burners when leak checking.

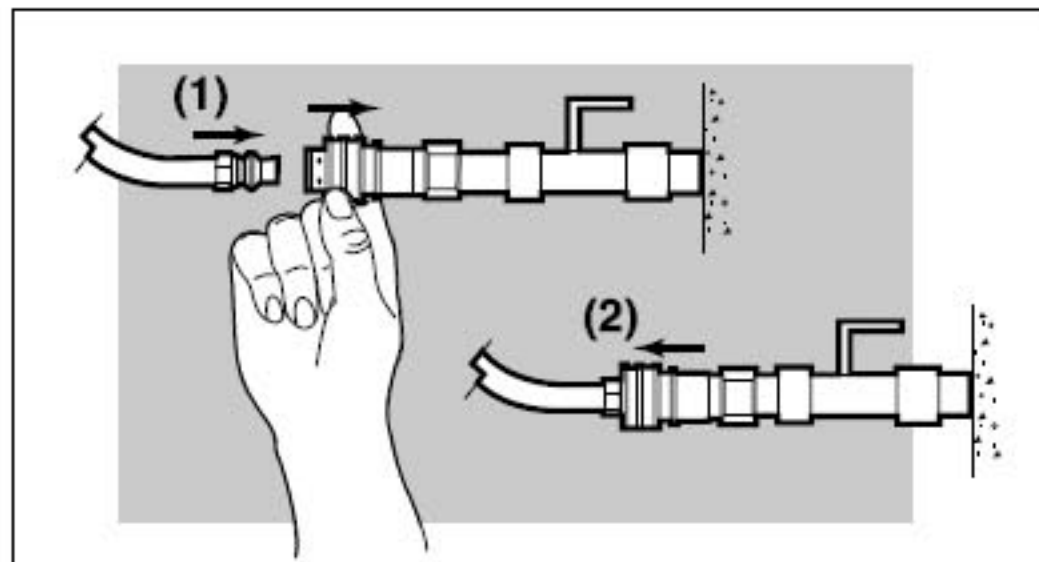



**E/S-420**

**CHECK:**

- 1) Bulkhead and gas supply hose connection.
- 2) Bulkhead to regulator connection.
- 3) Regulator to hose connection.
- 4) Main gas line to manifold connections.

**⚠ WARNING:** If there is a leak at connection (1, 2, 3, or 4), retighten the fitting with a wrench and recheck for leaks with soap and water solution.

If a leak persists after re-tightening the fitting, turn off the gas. **DO NOT OPERATE THE GRILL.** Contact the Customer Service Representative in your area using the contact information on our web site. Log onto [www.weber.com](http://www.weber.com)®.

- 5) Bulk head to side burner hose connection.
- 6) Side burner hose to quick disconnect connection, side burner valve and orifice connections.
- 7) Hose to quick disconnect connection.
- 8) Valves to manifold connections.

**⚠ WARNING:** If there is a leak at connections (5, 6, 7, or 8), turn off the gas. **DO NOT OPERATE THE GRILL.** Contact the Customer Service Representative in your area using the contact information on our web site.

Log onto [www.weber.com](http://www.weber.com)®.

When leak checks are complete, turn gas supply off at the source and rinse connections with water.

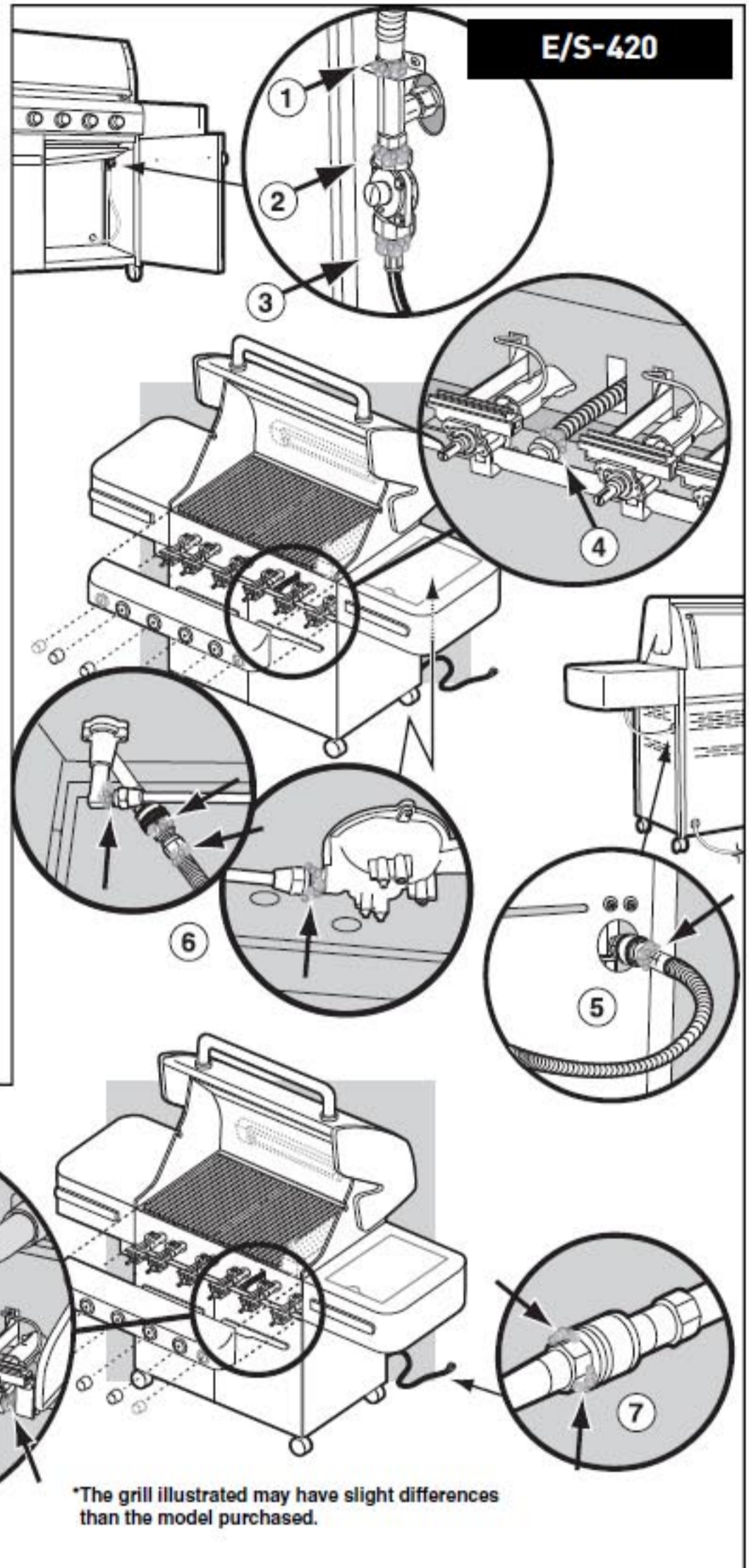



## CHECK:

- 1) Main gas line to manifold connection.
- 2) Rotisserie (I.R. Burner) gas line connection.
- 3) Bulkhead and gas supply hose connection.
- 4) Bulkhead to regulator connection.
- 5) Regulator to hose connection.

**⚠ WARNING:** If there is a leak at connection (1, 2, 3, 4, or 5), retighten the fitting with a wrench and recheck for leaks with soap and water solution.

If a leak persists after re-tightening the fitting, turn off the gas. **DO NOT OPERATE THE GRILL.** Contact the Customer Service Representative in your area using the contact information on our web site. Log onto [www.weber.com](http://www.weber.com)®.

- 6) Bulk head to side burner hose connection.
- 7) Side burner hose to quick disconnect connection, side burner valve and orifice connections.
- 8) Hose to quick disconnect connection.
- 9) Valves to manifold connections.

**⚠ WARNING:** If there is a leak at connections (6, 7, 8, or 9), turn off the gas. **DO NOT OPERATE THE GRILL.** Contact the Customer Service Representative in your area using the contact information on our web site.

Log onto [www.weber.com](http://www.weber.com)®.

When leak checks are complete, turn gas supply off at the source and rinse connections with water.

## REINSTALL CONTROL PANEL

Parts required: control panel, screws and burner control knobs.

Hook the top edge of the control panel onto the control panel brackets on either side of the front of the cooking box.

Line up screws with screw holes on both the control panel bracket and the frame.

Tighten screws.

Place corresponding control knobs onto the valve stems.

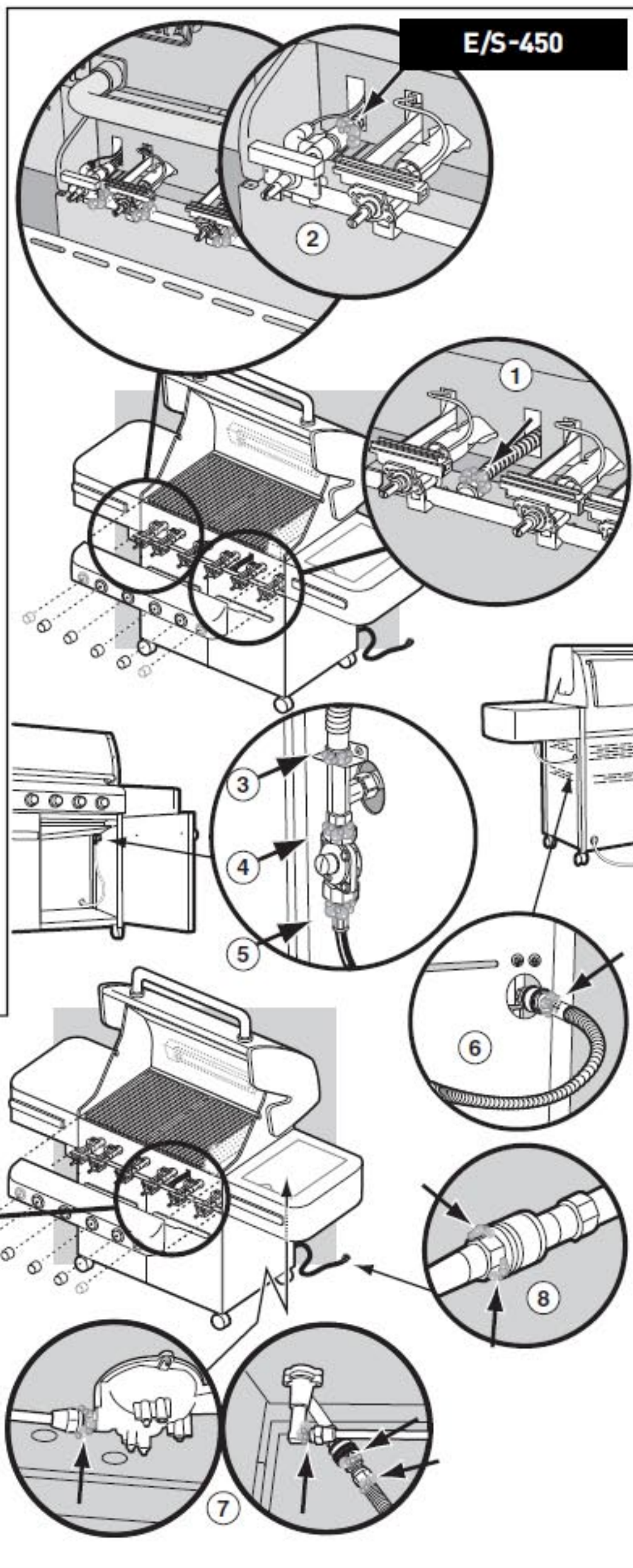

\*The grill illustrated may have slight differences than the model purchased.



## GRILLING METHODS

*Note: If grill loses heat while cooking refer to the troubleshooting section of this manual.*

You can adjust the individual burners as desired. The control settings are **START/Hi**, **MEDIUM**, **LOW**, or **OFF**.

If burners go out during cooking, turn off all burners and wait 5 minutes before relighting.

**⚠ WARNING: Check the bottom tray and catch pan for grease build-up before each use. Remove excess grease to avoid a grease fire in the bottom tray.**

## PREHEATING

Preheating the grill before grilling is important. Light your Summit® gas grill according to the instructions in this Owner's Manual. Turn all of the main burners to **Start/Hi**, close the lid, and preheat grill with the lid down until grill thermometer reaches 550°F (260°-288°C). This is the recommended broiling temperature. This will take approximately 10 to 15 minutes, depending on outside temperatures.

## COVERED COOKING

All grilling is done with the lid down to provide uniform, evenly circulated heat. With the lid closed, the Summit® gas grill cooks much like a convection oven. The thermometer in the lid indicates the cooking temperature inside the grill. All preheating and grilling is done with the lid down. No peeking — heat is lost every time you lift the lid.

## FLAVORIZER® SYSTEM

When meat juices drip from the food onto the specially angled Flavorizer® bars, they create smoke that gives foods an irresistible barbecued flavor. Thanks to the

The most important thing to know about grilling is which cooking method to use for a specific food, Direct or Indirect. The difference is simple: place the food directly over the fire, or arrange the fire on either side of it. Using the right method is the shortest route to great results—and the best way to ensure doneness safety.

## DIRECT COOKING

The Direct Method, similar to broiling, means the food is cooked directly over the heat source. For even cooking, food should be turned once halfway through the grilling time. Use the Direct method for foods that take less than 25 minutes to cook: steaks, chops, kabobs, sausages, vegetables, and more.

Direct cooking is also necessary to sear meats. Searing creates that wonderful crisp, caramelized texture where the food hits the grate. It also adds great color and flavor to the entire surface. Steaks, chops, chicken breasts, and larger cuts of meat all benefit from searing.

To sear meats, place them over Direct High heat for 2 to 5 minutes per side. Smaller pieces require less searing time. Usually after searing you finish cooking the food at a lower temperature. You can finish cooking fast-cooking foods by the Direct method; use the Indirect method for longer-cooking foods.

To set up your gas grill for Direct cooking, preheat the grill with all burners on "Hi". Place food on the cooking grate, and then adjust all burners to the temperature noted in the recipe. Close the lid of the grill and lift it only to turn food or to test for doneness at the end of the recommended cooking time.

## INDIRECT COOKING

The Indirect Method is similar to roasting, but with the added benefits of that grilled texture, flavor, and appearance you can't get from an oven. To set up for Indirect cooking, gas burners are lit on either side of the food but not directly beneath it. Heat rises, reflects off the lid and inside surfaces of the grill, and circulates to slowly cook the food evenly on all sides, much like a convection oven, so there's no need to turn the food.

Use the Indirect method for foods that require 25 minutes or more of grilling time or that are so delicate that direct exposure to the flame would dry them out or scorch them. Examples include roasts, ribs, whole chickens, turkeys, and other large cuts of meat, as well as delicate fish fillets.

To set up your gas grill for Indirect cooking, preheat the grill with all burners on "Hi". Then adjust the burners on each side of the food to the temperature noted in the recipe and turn off the burner(s) directly below the food. For best results, place roasts, poultry, or large cuts of meat on a roasting rack set inside a disposable heavy-gauge foil pan. For longer cooking times, add water to the foil pan to keep drippings from burning. The drippings can be used to make gravies or sauces.

D.	C.	B.	A.
OFF	START/ HI	MED.	LOW

unique design of the burners, Flavorizer® bars and the flexible temperature controls, uncontrolled flare-ups are virtually eliminated, because YOU control the flames. Because of the special design of the Flavorizer® bars and burners, excess fats are directed through the funnel-shaped bottom tray into the grease catch pan.

**4 burner**

food

1 2 3 4  
H H H H

**Direct Method**  
Food is placed on the area of the cooking grates directly over the lit burners.

**4 burner**

food

1 4  
M M

**Indirect Method**  
Food is placed on the area of the cooking grates between the lit burners.



## GRILLING TIPS & HELPFUL HINTS

- Always preheat the grill before cooking. Set all burners on "HI" heat and close lid; heat for 10 minutes, or until thermometer registers 500°-550°F (260°-288°C).
- Sear meats and cook with the lid down for perfectly grilled food every time.
- Grilling times in recipes are based on 70°F (20°C) weather and little or no wind. Allow more cooking time on cold or windy days, or at higher altitudes. Allow less cooking time in extremely hot weather.
- Grilling times can vary because of the weather, or the amount, size and shape of the food being grilled.
- The temperature of your Summit® gas grill may run hotter than normal for the first few uses.
- Grilling conditions may require the adjustment of the burner controls to attain the correct cooking temperatures.
- In general, large pieces of meat will require more cooking time per pound than small pieces of meat. Foods on a crowded cooking grate will require more cooking time than just a few foods. Foods grilled in containers, such as baked beans, will require more time if grilled in a deep casserole rather than a shallow baking pan.
- Trim excess fat from steaks, chops and roasts, leaving no more than a scant ¼ inch (6.4mm) of fat. Less fat makes cleanup easier, and is a virtual guarantee against unwanted flare-ups.
- Foods placed on the cooking grate directly above burners may require turning or moving to a less hot area.
- Use tongs rather than a fork for turning and handling meats to avoid losing natural juices. Use two spatulas for handling large whole fish.
- If an unwanted flare-up should occur, turn all burners off and move food to another area of the cooking grate. Any flames will quickly subside. After flames subside, relight the grill. NEVER USE WATER TO EXTINGUISH FLAMES ON A GAS GRILL.
- Some foods, such as a casserole or thin fish fillets, will require a container for grilling. Disposable foil pans are very convenient, but any metal pan with ovenproof handles can also be used.
- Always be sure the bottom tray and grease catch pan are clean and free from debris.
- Do not line the funnel-shaped bottom tray with foil. This could prevent the grease from flowing into the grease catch pan.
- Using a timer will help to alert you when "well-done" is about to become "over-done."

## SNAP IGNITION OPERATION

### ⚠ Always open the lid before igniting the burners

Each control knob has its own igniter electrode built in. To create a spark you must push the control knob in (A) and turn to "START/High" (B).

This action will generate gas flow and a spark to the burner lighting tube (C). You will hear a "snap" from the igniter. You will also see a 3" - 5" orange flame coming from the burner lighting tube at the left side of the burner (D).

Continue to hold the burner control knob in for two seconds after the "snap". This will allow gas to flow completely down the burner tube (E) and insure ignition.

Check that the burner is lit by looking through the cooking grates. You should see a flame. If burner does not light on first try, push control knob in and turn to OFF. Repeat lighting procedure a second time.

⚠ **WARNING:** If the burner still does not light, turn the burner control knob to "OFF" and wait 5 minutes to let the gas clear before you try again or try to light with a match.

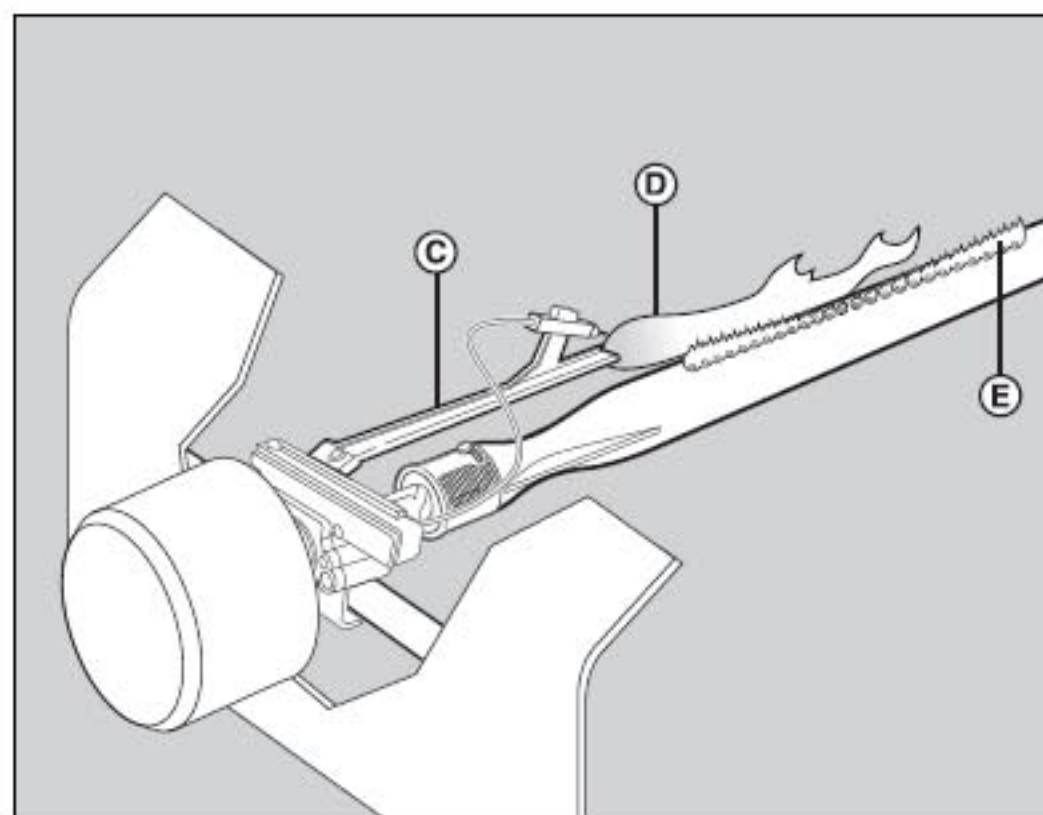
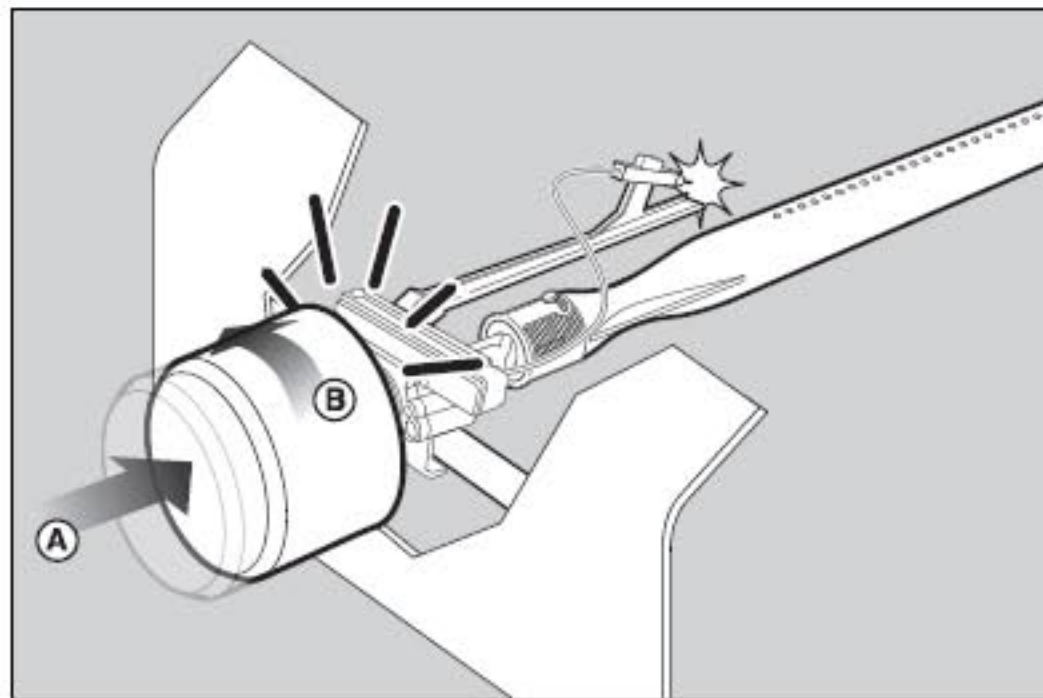



**LIGHTING**

Summary lighting instructions are inside the left hand cabinet door.

**⚠ DANGER**

Failure to open the lid while igniting the barbecue's burners, or not waiting 5 minutes to allow the gas to clear if the barbecue does not light, may result in an explosive flame-up which can cause serious bodily injury or death.

**MAIN BURNER SNAP IGNITION**

*Note: Each control knob snap igniter creates a spark from the igniter electrode to the burner lighting tube. You generate the energy for the spark by pushing in the control knob and turning to "START/HI". This will ignite each individual burner.*

**⚠ WARNING:** Check hose before each use of barbecue for nicks, cracking, abrasions or cuts. If the hose is found to be damaged in any way, do not use the barbecue. Replace using only Weber® authorized replacement hose. Contact the Customer Service Representative in your area using the contact information on our web site.

Log onto [www.weber.com](http://www.weber.com)®.

- 1) Open the lid.
- 2) Make sure all burner control knobs are turned to "OFF". (Push control knob in and turn clockwise to ensure that it is in the "OFF" position.)
- 3) Turn on the gas supply at source.

**⚠ WARNING:** Do not lean over the open barbecue.

- 4) Push the control knob in and turn to "START/HI" until you hear the igniter snap - continue to hold control knob in for two seconds. This action will spark the igniter, the burner lighting tube and then main burner.
- 5) Check that the burner is lit by looking through the cooking grates. You should see a flame. If burner does not light on first try, push control knob in and turn to OFF. Repeat lighting procedure a second time.

**⚠ WARNING:** If the burner still does not light, turn the burner control knob to "OFF" and wait 5 minutes to let the gas clear before you try again or try to light with a match.

**MAIN BURNER LIGHTING**

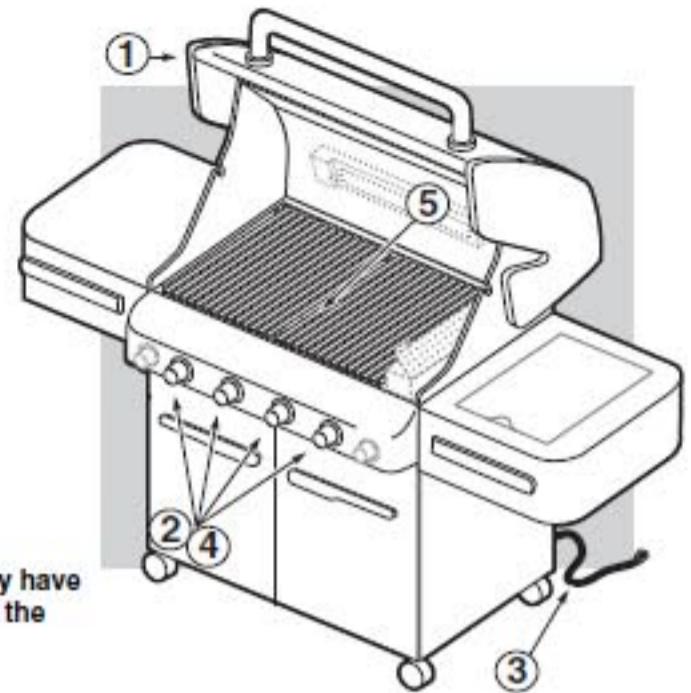

\*The grill illustrated may have slight differences than the model purchased.

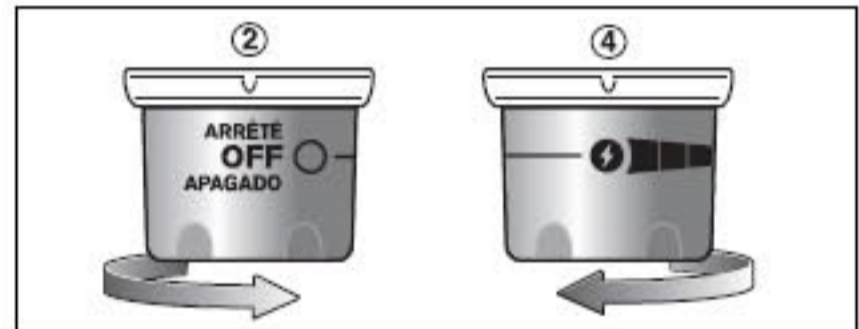

**TO EXTINGUISH**

Push in and turn each burner control knob clockwise to "OFF" position. Turn gas supply off at the source.

**MAIN BURNER MANUAL LIGHTING**

**⚠ DANGER**

Failure to open the lid while igniting the barbecue's burners, or not waiting 5 minutes to allow the gas to clear if the barbecue does not light, may result in an explosive flame-up which can cause serious bodily injury or death.

- 1) Open the lid.
- 2) Make sure all burner control knobs are turned to "OFF". (Push each knob in and turn clockwise to ensure they are in the "OFF" position.)
- 3) Turn on the gas supply at source.
- 4) Put match in the match holder and strike match.

**⚠ WARNING:** Do not lean over open barbecue.

- 5) Insert match holder and lit match down through cooking grates and Flavorizer® bars to ignite the selected burner.
- 6) Push the control knob in and turn to "START/HI".

**⚠ WARNING:** If the burner does not light, turn burner control knob to "OFF" and wait 5 minutes to let the gas clear before you try again.

**TO EXTINGUISH**

Push in and turn each burner control knob clockwise to "OFF" position. Turn gas supply off at the source.

**MAIN BURNER MANUAL LIGHTING**

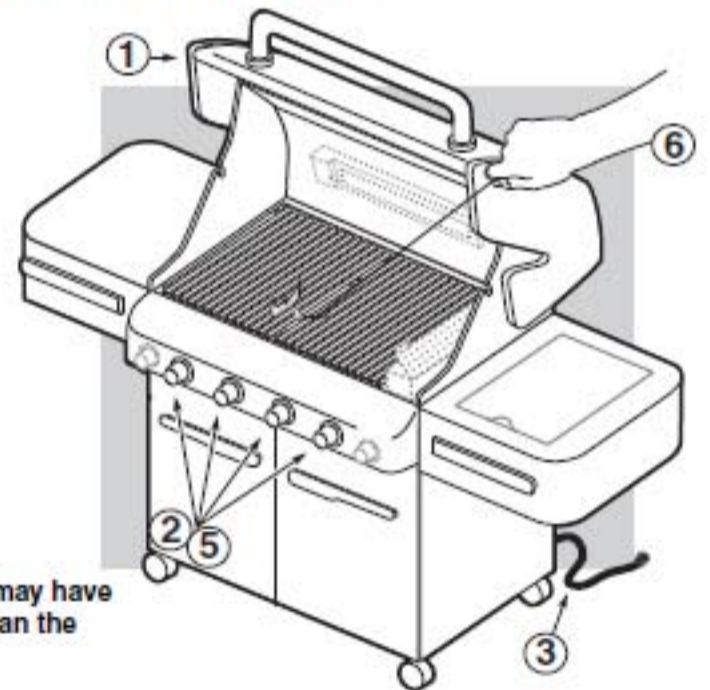

\*The grill illustrated may have slight differences than the model purchased.

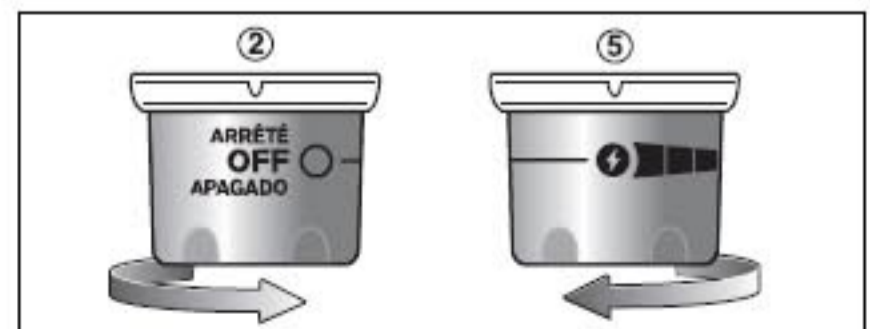



## LIGHTING THE SIDE BURNER

**⚠ DANGER**

Failure to open the lid while igniting the side burner, or not waiting 5 minutes to allow the gas to clear if the side burner does not light, may result in an explosive flame-up which can cause serious bodily injury or death.

**⚠ WARNING:** Check hose before each use of barbecue for nicks, cracking, abrasions or cuts. If the hose is found to be damaged in any way, do not use the barbecue. Replace using only Weber® authorized replacement hose. Contact the Customer Service Representative in your area using the contact information on our web site. Log onto [www.weber.com](http://www.weber.com)®.

- 1) Open the side burner lid.
- 2) Check that the side burner valve is turned off (Push control knob in and turn clockwise to ensure that it is in the "OFF" position), turn all burners not being used to the "OFF" position (push in and turn clockwise).
- 3) Turn the gas supply valve on.
- 4) Push down and turn the side burner control valve to "HI".
- 5) Press the igniter button several times so it clicks each time.

**⚠ CAUTION:** Side burner flame may be difficult to see on a bright sunny day.

**⚠ WARNING:** If the side burner does not light in five (5) seconds:

- a) Turn off the side burner control valve, main burners and gas supply at source.
- b) Wait 5 minutes to let the gas clear before you try again, or try lighting with a match (see "Manually Lighting the Side Burner").

## SIDE BURNER LIGHTING

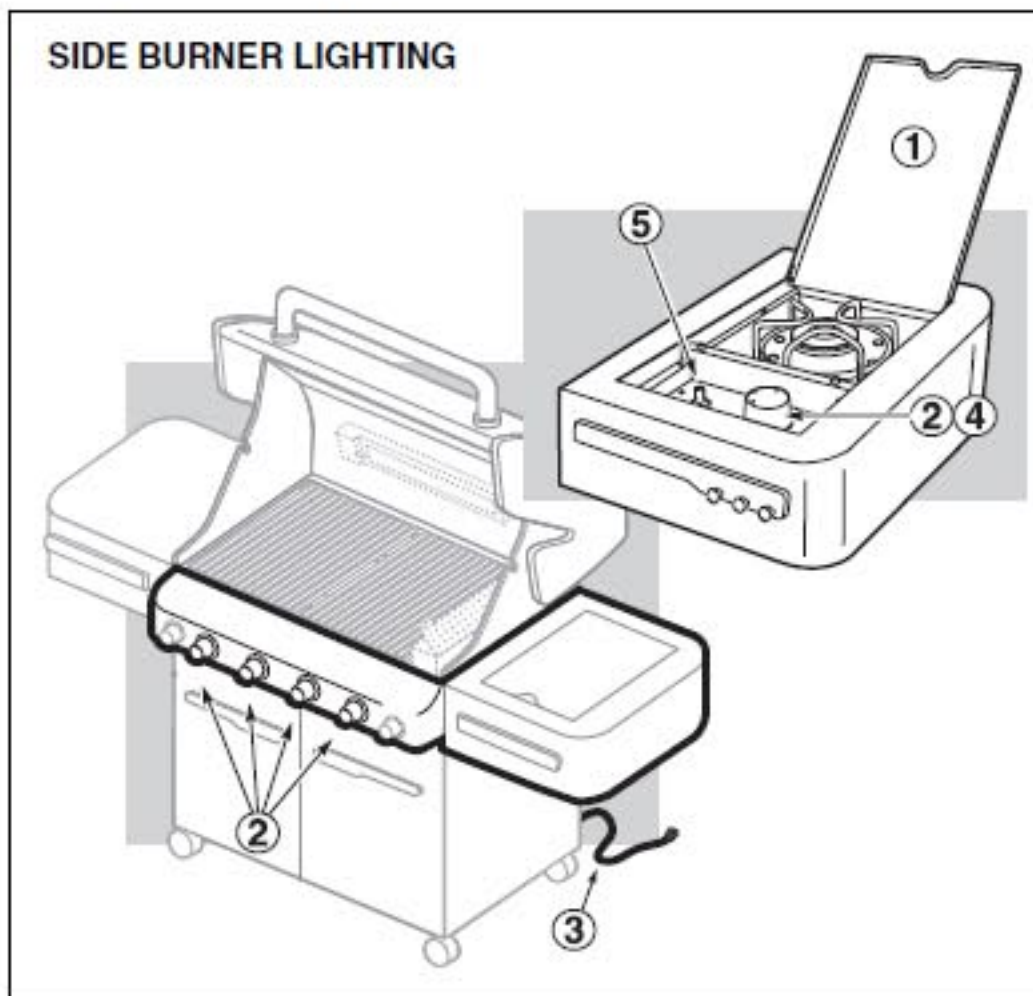

## MANUALLY LIGHTING THE SIDE BURNER

**⚠ DANGER**

Failure to open the lid while igniting the side burner, or not waiting 5 minutes to allow the gas to clear if the side burner does not light, may result in an explosive flare-up that can cause serious bodily injury or death.

- 1) Open the side burner lid.
- 2) Check that the side burner valve is turned off (Push control knob in and turn clockwise to ensure that it is in the "OFF" position), turn all burners not being used to the "OFF" position (push in and turn clockwise).
- 3) Turn the gas supply valve on.
- 4) Put match in a match holder and strike match.
- 5) Hold match holder and lit match by either side of the side burner.
- 6) Push down and turn the side burner control valve to "HI".

**⚠ CAUTION:** Side burner flame may be difficult to see on a bright sunny day.

**⚠ WARNING:** If the side burner does not light in five (5) seconds:

- a) Turn off the side burner control valve, main burners and gas supply at source.
- b) Wait 5 minutes to let the gas clear before you try again.

## MANUAL SIDE BURNER LIGHTING

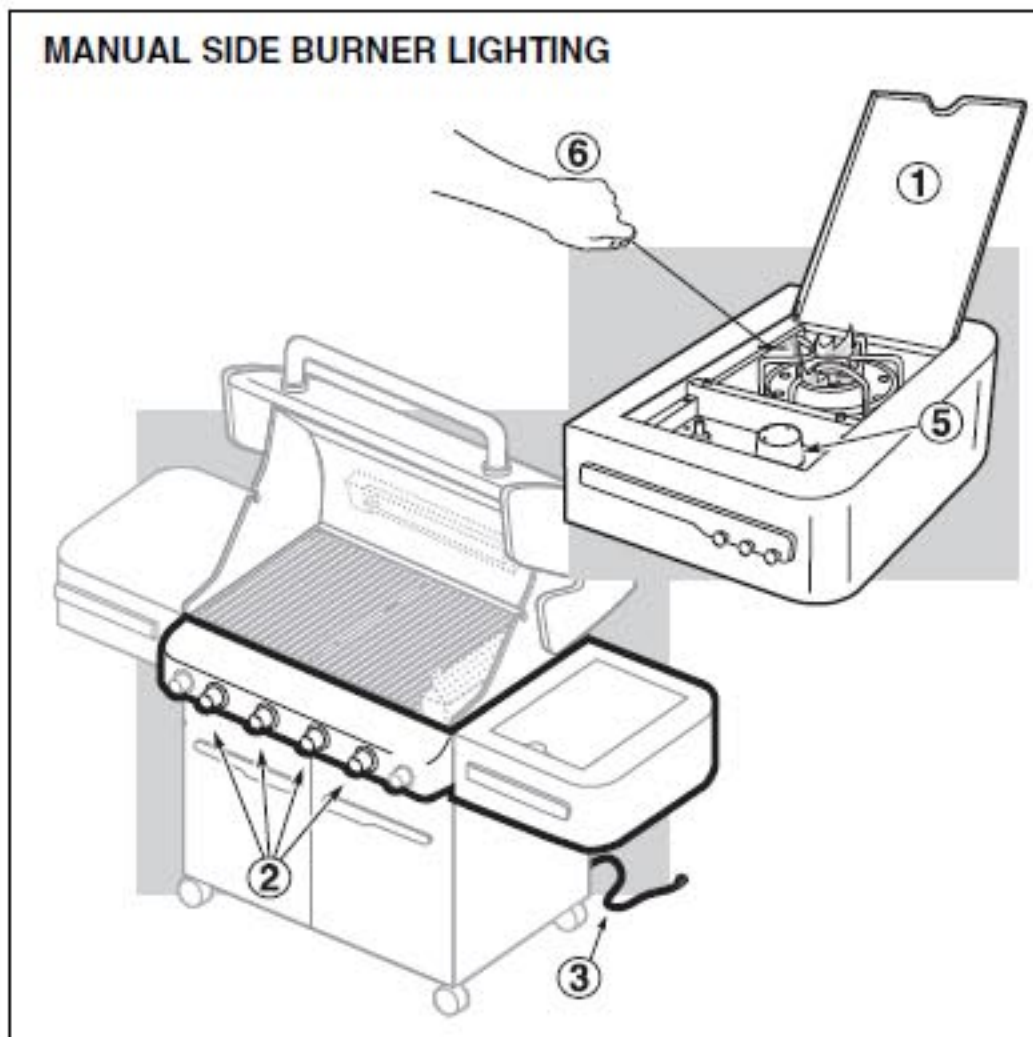



## USING THE SMOKER

The smoker uses presoaked wood chips. For best results with faster cooking foods like steaks, burgers and chops, etc., we recommend using finer wood chips because they ignite and create smoke faster. For longer cooking foods such as roasts, chicken and turkeys, etc., we recommend using larger wood chunks because they ignite slowly and provide smoke for a longer period of time. As you gain experience in using your smoker, we encourage you to experiment with different combinations of wood chips and chunks to find the smoke flavor that best suits your taste.

## TO USE THE SMOKER

As a starting point, soak wood chips in water for at least 30 minutes before using. (Wet wood will produce more smoke flavor.) Place a handful of wood chips or a few larger chunks in the bottom of the smoker body (1). As you gain experience in smoking, increase or decrease the amount of wood to suit your taste.

*Note: Always grill with the lid closed to allow the smoke to fully penetrate the food. Light the smoker burner by following the instructions for Lighting The Smoker Burner. After wood starts to smolder turn control knob to "LOW".*

Smoke will start in approximately 10 minutes and last as long as 45 minutes. If you require more smoke flavor, refill the smoker with wood chips and /or chunks. Keep the lid of the grill closed while cooking.

*Note: After refilling smoker, smoke will take about 10 to 15 minutes to start again. The smoker may be used to enhance meat, poultry and fish recipes. Cook with the lid down according to the times indicated in charts or recipes.*

### ⚠ DANGER

**Do not use any flammable fluid in the smoker to ignite the wood. This will cause serious bodily injury.**

## E/S-450

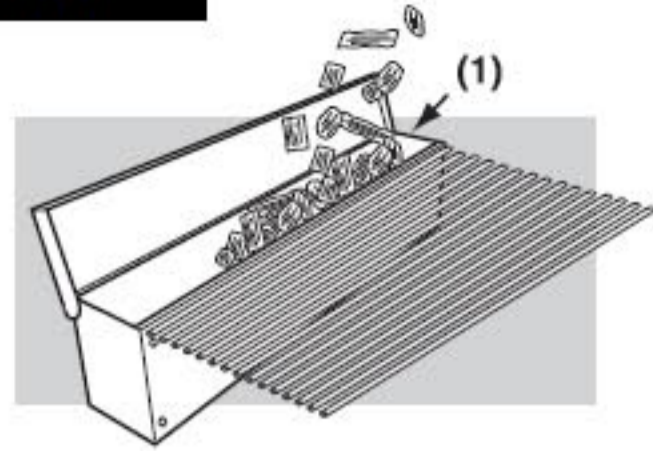

## CLEANING THE SMOKER

Before each use, empty the smoker of ash to allow proper air flow.

*Note: Smoking will leave a "smoke" residue on the surface of the smoker. This residue cannot be removed and will not affect the function of the smoker. To a lesser degree a "smoke" residue will accumulate on the inside of your gas grill. This residue need not be removed and will not adversely affect the function of your gas grill.*

## LIGHTING THE SMOKER BURNER

### ⚠ DANGER

**Failure to open the lid while igniting the grill, or not waiting 5 minutes to allow the gas to clear if the grill does not light, may result in an explosive flare-up which can cause serious bodily injury or death.**

## SMOKER BURNER SNAP IGNITION

*Note: The control knob snap igniter creates a spark from the igniter electrode to the burner lighting tube. You generate the energy for the spark by pushing in the control knob and turning to "START/HI". This will ignite the smoker burner.*

**⚠ WARNING: Check hose before each use of grill for nicks, cracking, abrasions or cuts. If the hose is found to be damaged in any way, do not use the grill. Replace using only Weber® authorized replacement hose. Contact the Customer Service Representative in your area using the contact information on our web site. Log onto [www.weber.com](http://www.weber.com)®.**

- 1) Open the grill lid.
  - 2) Open smoker box lid.
  - 3) Fill smoker with water soaked wood chunks or chips.
  - 4) Make sure that all burner control knobs not being used are turned to "OFF". (Push control knob in and turn clockwise to ensure that it is in the "OFF" position).
  - 5) Turn on the gas at source.
- ⚠ WARNING: Do not lean over the open grill while lighting.**
- 6) Push the control knob in and turn to "START/HI" until you hear the igniter snap - continue to hold control knob in for two seconds. This action will spark the igniter, the burner lighting tube and then main burner.
  - 7) Check that the burner is lit by looking through the cooking grates. You should see a flame. If burner does not light on first try, push control knob in and turn to OFF. Repeat lighting procedure a second time

### ⚠ DANGER

**If the smoker burner does not light, turn the burner control knob to "OFF" and wait 5 minutes to let the gas clear before attempting to light.**

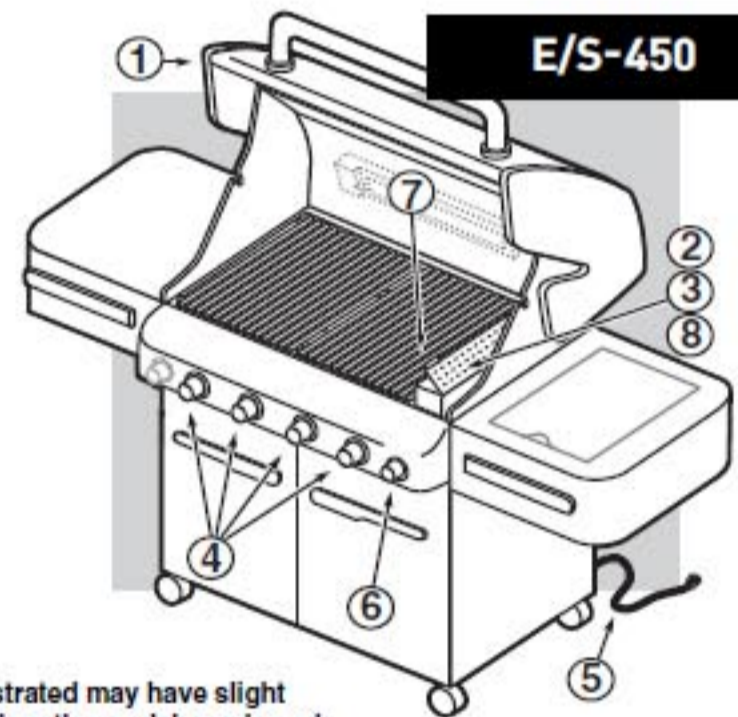

\*The grill illustrated may have slight differences than the model purchased.

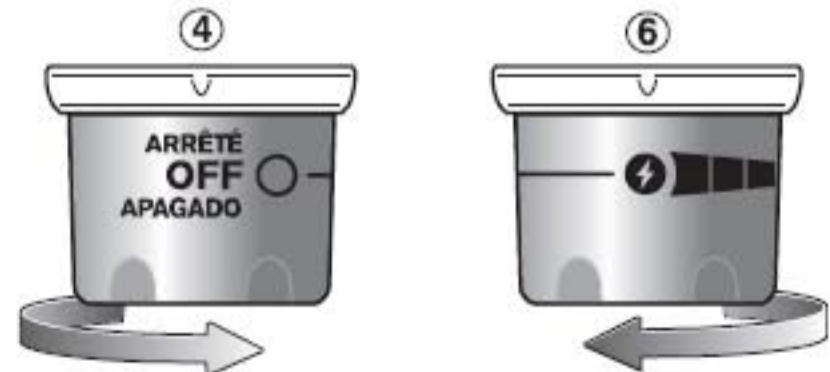

- 8) Close smoker cover after wood starts to smolder and turn control knob to "LOW".

## TO EXTINGUISH

Push in and turn each burner control knob clockwise to "OFF" position. Turn gas supply off at the source.



## MANUALLY LIGHTING THE SMOKER BURNER

- 1) Open the lid.

**⚠ DANGER**

Failure to open the lid while igniting the grill, or not waiting 5 minutes to allow the gas to clear if the grill does not light, may result in an explosive flare-up which can cause serious bodily injury or death.

- 2) Open smoker box lid
- 3) Fill smoker with water soaked wood chunks or chips.
- 4) Make sure that all burner control knobs not being used are turned to "OFF". (Push control knob in and turn clockwise to ensure that it is in the "OFF" position.)
- 5) Turn on the gas at source.
- 6) Put a match in the match holder and strike the match.
- 7) Insert match holder and lit match down through cooking grates and Flavorizer® bars to ignite smoker burner.

**⚠ WARNING: Do not lean over the open grill while lighting.**

- 8) Push smoker burner control knob in and turn to "START/HI".
- 9) Check that the burner is lit by looking down through the cooking grate.

**⚠ DANGER**

If the smoker burner does not light, turn the burner control knob to "OFF" and wait 5 minutes to let the gas clear before you try again.

- 10) Close smoker cover after wood starts to smolder and turn control knob to "LOW".

## TO EXTINGUISH

Push in and turn each burner control knob clockwise to "OFF" position. Turn gas supply off at the source.

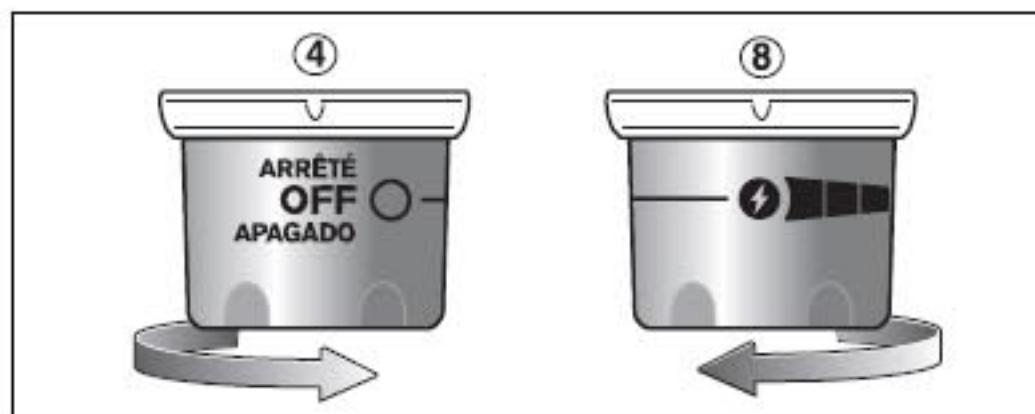
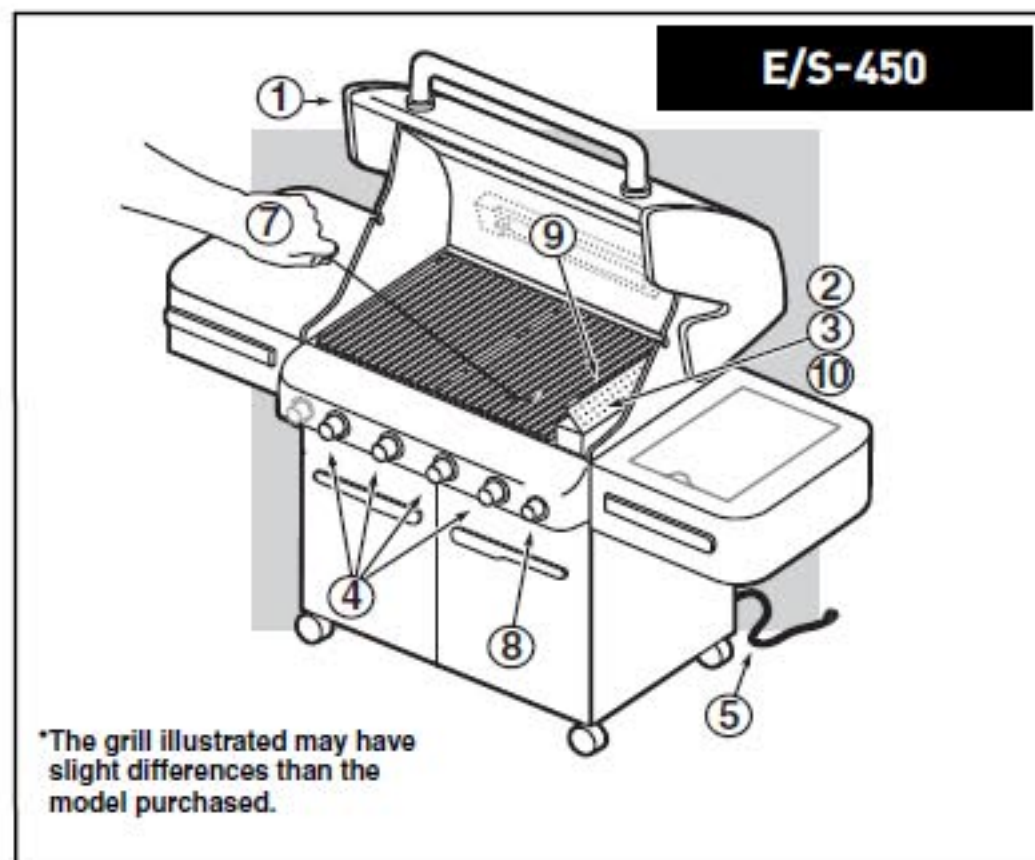

## USING THE ROTISSERIE

*Note: Before using your rotisserie, measure your food at the widest point. If it exceeds 9½" (241.8mm), it is too large to fit the rotisserie. If it is too large, food can be prepared using a roast holder and the Indirect Cooking Method.*

## IMPORTANT SAFEGUARDS

**⚠ WARNINGS**

- Read all instructions before using your rotisserie.
- This rotisserie is for outdoor use only.
- Remove motor and store in a dry place when not in use.
- Do not touch hot surfaces. Use barbecue mitts.
- This rotisserie is not for use by children.
- To protect against electrical hazards do not immerse cord, plugs, or motor in water or other liquids.
- Unplug the motor from outlet when not in use or before cleaning.
- Do not use rotisserie for other than intended use.
- Make sure motor is off before placing it on the motor bracket.
- Do not operate the rotisserie motor with a damaged cord or plug.
- Do not operate the rotisserie motor if it should malfunction.
- The rotisserie motor is equipped with a three prong (grounding) power cord for your protection against shock hazard.
- The power cord should be plugged directly into a properly grounded three prong receptacle. If use of an extension cord is required, be sure that it is a minimum 16 AWG(1.3mm), 3-wire, well insulated cord marked for OUTDOOR USE ONLY and properly grounded.
- When using an extension cord, make sure it is not in contact with a hot or sharp surface.
- Outdoor extension cords should be marked with the letters "W-A" and a tag stating "Suitable for use with outdoor appliances".
- Do not cut or remove the grounding prong from the rotisserie motor power cord.
- Do not let cord hang over any sharp edge or hot surface.
- Do not expose to rain.
- To reduce the risk of electric shock, keep extension cord connection dry and off the ground.
- A short power cord is supplied to reduce the risk of tripping over the cord. Extension cords may be used, but caution must be taken to prevent tripping over the cord.
- In absence of local codes the rotisserie motor must be grounded electrically in accordance with the National Electric Code, ANSI / NFPA 70, or Canadian Electrical Code, CSA C22.1.



**⚠ WARNING: Setup up the rotisserie with food before lighting rotisserie burner.**

## OPERATING

---

- 1) Remove rotisserie shaft from grill. Remove one spit fork.
- 2) Push the rotisserie shaft through the center of the food.
- 3) Slide the spit fork onto the shaft. Insert the tines of both spit forks into the food. The food should be centered on the shaft. Tighten the spit fork screws
- 4) Place the motor in the bracket, slide to lock.
- 5) Insert the pointed end of the rotisserie shaft into the motor. Place the handle end of the rotisserie onto the support rollers.
- 6) The rotisserie shaft should rotate so that the heavy side of the meat or poultry rotates down to the bottom. Large cuts may require the removal of the cooking grates and warming rack to allow full rotation of the shaft. Remount the food if necessary for better balance.
- 7) Turn the motor on.

## COOKING

---

- Meats (except poultry and ground meat) should be brought to room temperature before cooking. (20 to 30 minutes should be adequate for most foods. If frozen defrost completely before cooking.)
- Tie meat or poultry with a string, if necessary, to make the shape as uniform as possible before putting it on the spit.
- Remove cooking grates and warming rack to allow food to turn freely.
- Follow lighting instructions for rotisserie burner on next page.
- Set rotisserie burner on medium-high based on outside air temperatures.
- Place food within area of burner.
- If you wish to save drippings for gravy, place a drip pan directly under the food on top of the Flavorizer® bars.
- Food preparation steps are the same for rotisserie cooking as for regular cooking.
- All cooking is done with the lid closed.
- If foods are too heavy or are irregular shapes, they may not rotate well and should be cooked by the Indirect Method without using the rotisserie.
- Smoker can be used in conjunction with rotisserie for more smoke flavor.

*Note: When using the rotisserie burner, grill thermometer will not reflect the temperature inside the cooking box.*



## LIGHTING THE ROTISSERIE BURNER

## ROTISSERIE BURNER SNAP IGNITION

*Note: Each control knob snap igniter creates a spark from the igniter electrode to the burner lighting tube. You generate the energy for the spark by pushing in the control knob and turning to "START/HI". This will ignite each individual burner.*

**⚠ ATTENTION: READ BEFORE LIGHTING ROTISSERIE BURNER**

After a period of non-use, before lighting the Rotisserie Burner, a few seconds must pass for the gas supply line to fill.

When using the snap igniter you will see a flash of flames moving from left to right across the Rotisserie Burner surface, the Rotisserie Burner is not lit until the entire ceramic surface is aflame.

At this point, start a count of 20 seconds before releasing the Rotisserie Burner control knob.

The Rotisserie Burner surface will glow red once the burner is fully ignited.

**⚠ DANGER**

Failure to open the lid while igniting the grill, or not waiting 5 minutes to allow the gas to clear if the grill does not light, may result in an explosive flare-up which can cause serious bodily injury or death.

**⚠ CAUTION:** The Rotisserie Burner flame may be difficult to see on a bright sunny day.

**⚠ WARNING:** Check hose before each use of grill for nicks, cracking, abrasions or cuts. If the hose is found to be damaged in any way, do not use the grill. Replace using only a Weber® authorized replacement hose. Contact the Customer Service Representative in your area using the contact information on our web site.

Log onto [www.weber.com](http://www.weber.com)®.

- 1) Open the lid.
  - 2) Remove the warming rack and the cooking grates from the cookbox.
  - 3) Make sure all burner control knobs are turned to "OFF". (Push control knob in and turn clockwise to ensure that it is in the "OFF" position.)
  - 4) Turn on the gas at source.
- ⚠ WARNING: Do not lean over the open grill.**
- 5) Push the control knob in and turn to "START/HI". This action will spark the igniter and light the Rotisserie Burner. Continue to use the snap igniter until the Rotisserie Burner has ignited. Release the control knob.
  - 6) Check that the burner is lit by looking for the rotisserie burner to glow red.

E/S-450

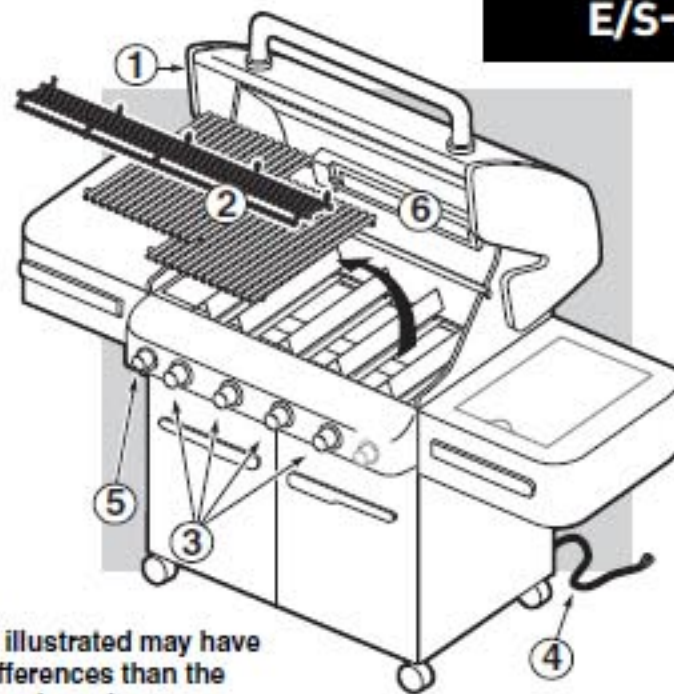

\*The grill illustrated may have slight differences than the model purchased.

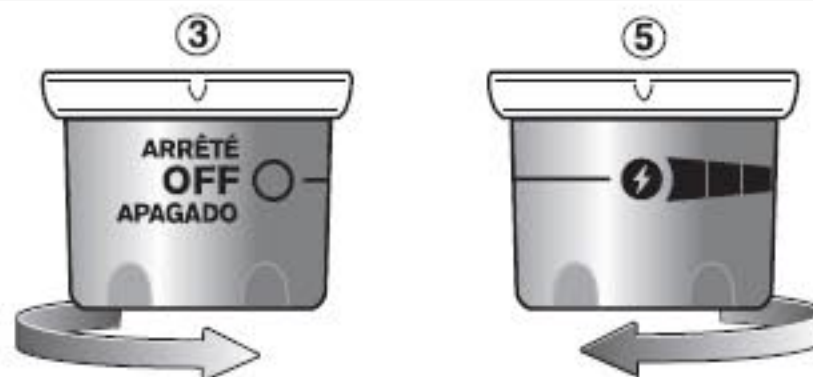

**⚠ WARNING:** If the rotisserie burner does not light, turn the burner control knob to "OFF" and wait 5 minutes to let the gas clear before you try again or try to light with a match.

*Note: When using the rotisserie with the lid closed, only light two of the main burners on each side of the food (See Grilling Methods-Indirect Cooking). Check your food periodically to prevent over cooking on the outside. Turn off the rotisserie burner once the food has browned to the desired color. Finish cooking on Indirect heat.*

**TO EXTINGUISH**

Push in and turn each burner control knob clockwise to "OFF" position. Turn gas supply off at the source.



MANUALLY LIGHTING THE ROTISSERIE BURNER

**⚠ ATTENTION: READ BEFORE LIGHTING ROTISSERIE BURNER**

After a period of non-use, before lighting the Rotisserie Burner, a few seconds must pass for the gas supply line to fill. When holding a match to the rotisserie burner you will see a flash of flames moving from left to right across the Rotisserie Burner surface, the Rotisserie Burner is not lit until the entire ceramic surface is aflame. At this point, start a count of 20 seconds before releasing the Rotisserie Burner control knob. The Rotisserie Burner surface will glow red once the burner is fully ignited.

**⚠ DANGER**

Failure to open the lid while igniting the grill, or not waiting 5 minutes to allow the gas to clear if the grill does not light, may result in an explosive flare-up which can cause serious bodily injury or death.

**⚠ CAUTION:** The Rotisserie Burner flame may be difficult to see on a sunny day.

**⚠ WARNING:** Check hose before each use of grill for nicks, cracking, abrasions or cuts. If the hose is found to be damaged in any way, do not use the grill. Replace using only a Weber® authorized replacement hose. Contact the Customer Service Representative in your area using the contact information on our web site.

Log onto [www.weber.com](http://www.weber.com)®.

- 1) Open the lid.
- 2) Remove the warming rack and the cooking grates from the cookbox.
- 3) Make sure all burner control knobs are turned to "OFF". (Push control knob in and turn clockwise to ensure that it is in the "OFF" position.)
- 4) Turn on the gas at source.
- 5) Put a match in the match holder and strike the match.
- 6) Hold match holder and lit match by right side of rotisserie burner.

**⚠ WARNING: Do not lean over the open grill.**

- 7) Push rotisserie burner control knob down and turn to "START/HI". Continue to hold the control knob down until twenty (20) seconds after the burner has ignited.
- 8) Check that the burner is lit by looking for the rotisserie burner to glow red.

**E/S-450**

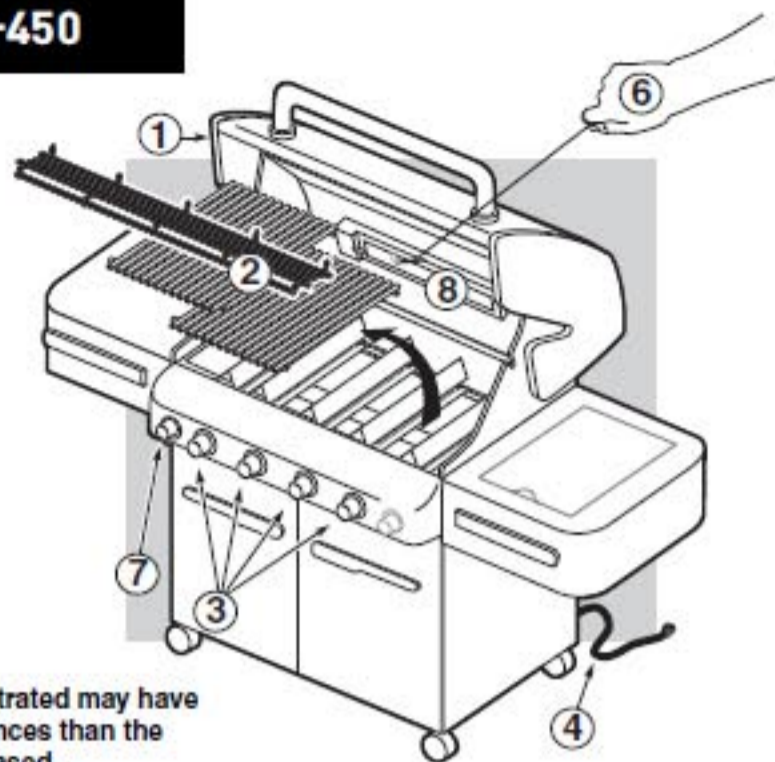

\*The grill illustrated may have slight differences than the model purchased.

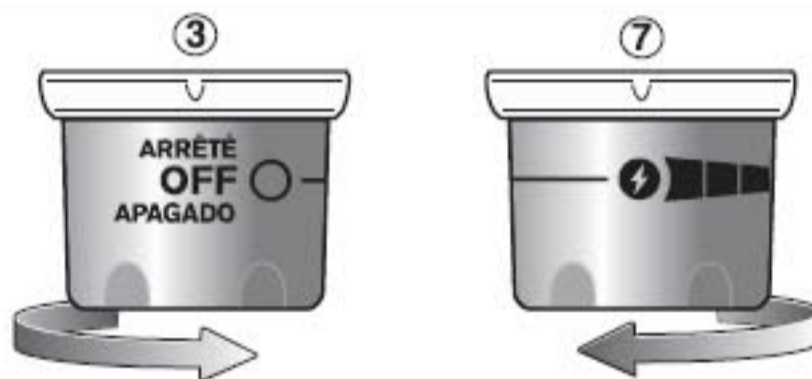

**⚠ WARNING: If the rotisserie burner does not light, turn the burner control knob to "OFF" and wait 5 minutes to let the gas clear before you try again.**

*Note: When using the rotisserie with the lid closed, only light two of the main burners under the food (See Grilling Methods-Indirect Cooking). Check your food periodically to prevent over cooking on the outside. Turn off the rotisserie burner once the food has browned to the desired color. Finish cooking on Indirect heat.*

**TO EXTINGUISH**

Push in and turn each burner control knob clockwise to "OFF" position. Turn gas supply off at the source.



### OPERATING THE HANDLE LIGHT

The Weber Grill Out™ Handle Light has a built-in "Tilt Sensor." With the power button (a) activated, the light will come on when the grill lid is open. The light will turn off when the lid is closed. For daytime use, deactivate the sensor by pressing power button (a).



### HANDLE LIGHT TROUBLESHOOTING

PROBLEM	CHECK	CURE
Weber Grill Out™ Handle Light does not light.	Are the batteries old?	Replace batteries.
	Are the batteries installed correctly?	See assembly illustration.
	Is the lid in the up position with the power button ON?	Light will activate when lid is open.
	Is the Weber Grill Out™ Handle Light activated?	Press the power button.
	Is the Weber Grill Out™ Handle Light positioned correctly on the handle?	Adjust position (See assembly illustration).

If problems cannot be corrected by using these methods, please contact the Customer Service Representative in your area using the contact information on our web site. Log onto [www.weber.com](http://www.weber.com)®.

### ROTISSERIE TROUBLESHOOTING

PROBLEM	CHECK	CURE
Rotisserie burner does not light.	Did you hold the burner control knob in and hold in for 20 seconds until after burner ignited?	Try to relight burner by holding burner control knob in and continue holding in until 20 seconds after burner has ignited.
	Did you wait to see the entire ceramic surface become alight before counting 20 seconds?	When relighting burner by holding burner control knob in, wait to see the entire ceramic surface become alight before counting 20 seconds?
	Did you repeatedly use the snap ignition until the burner ignited?	After waiting five minutes for gas to clear, try repeatedly using the snap igniter until the burner ignites (refer to "Lighting the Rotisserie Burner").
	Does the igniter work (Do you see a spark when you repeatedly use the snap igniter?)	Try manually lighting the burner (refer to "Lighting the Rotisserie Burner"). Call customer service.

If problems cannot be corrected by using these methods, please contact the Customer Service Representative in your area using the contact information on our web site. Log onto [www.weber.com](http://www.weber.com)®.

### SIDE BURNER TROUBLESHOOTING

PROBLEM	CHECK	CURE
Side Burner does not light.	Is gas supply off?	Turn supply on.
Flame is low in "HI" position	Is the fuel hose bent or kinked?	Straighten hose.
Push button ignition does not work.	Does burner light with a match?	If match lights burner, check igniter (see below).

If problems cannot be corrected by using these methods, please contact the Customer Service Representative in your area using the contact information on our web site. Log onto [www.weber.com](http://www.weber.com)®.



## SIDE BURNER MAINTENANCE

**⚠ WARNING:** All gas controls and supply valves should be in the "OFF" position.

Make sure black wire is connected between the igniter and electrode.  
 Make sure white wire is connected between the igniter and grounding clip.  
 Spark should be a white/blue color, not yellow.

- 1) Igniter Wire
- 2) Ground wire
- 3) Burner

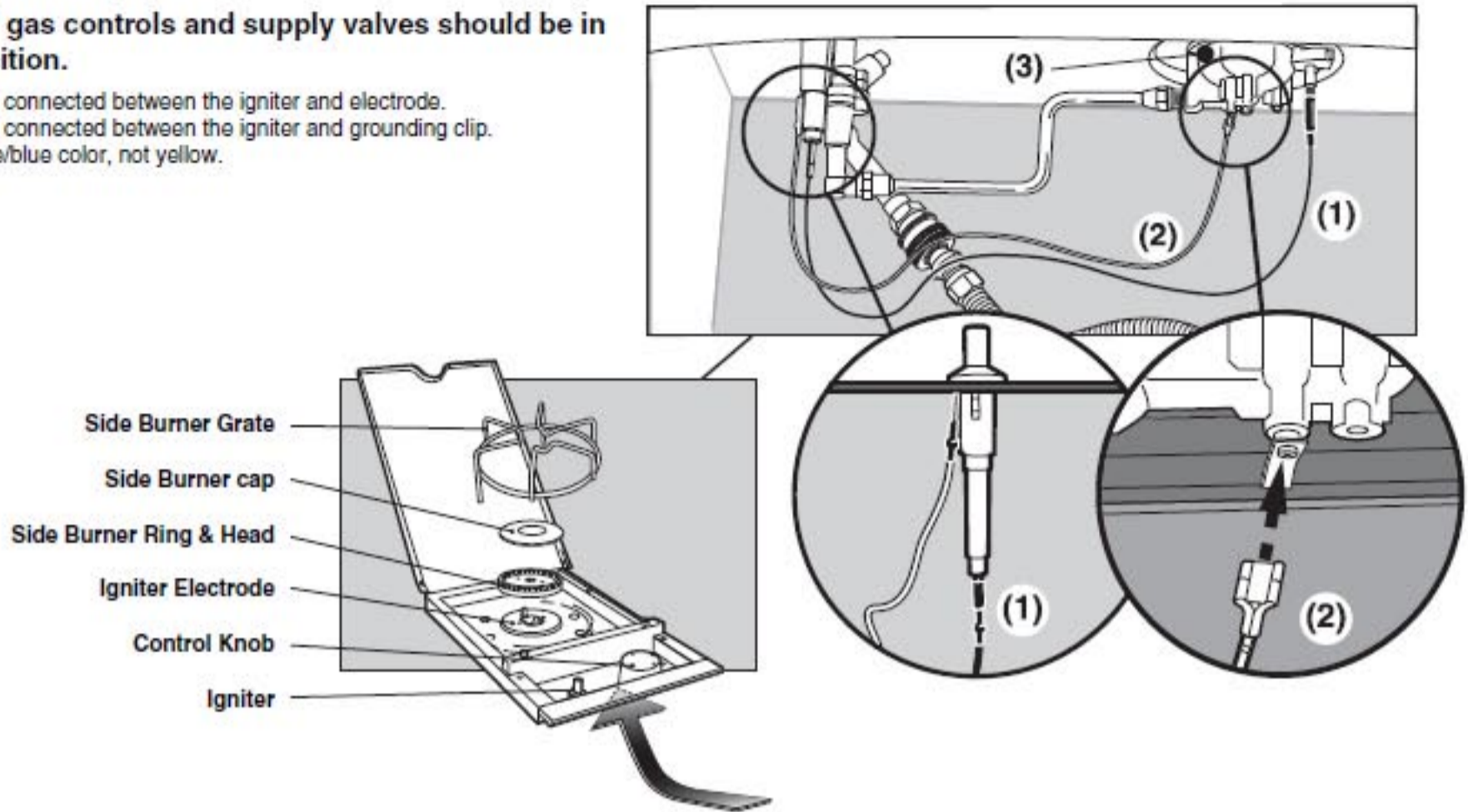

## TROUBLESHOOTING

PROBLEM	CHECK	CURE
Burners burn with a yellow or orange flame, in conjunction with the smell of gas (This is normal for the burner lighting tube).	Inspect Spider/Insect Screens for possible obstructions. (Blockage of holes.)	Clean Spider/Insect Screens. (See Section "Annual Maintenance")
<b>Symptoms:</b> Burner does not light, or flame is low in "HI" position.	Is fuel hose bent or kinked?	Straighten fuel hose.
	Does Burner light with a match?	If you can light Burner with a match, then check the Crossover <sup>®</sup> ignition system.
	Did you use the snap igniter several times until the main burner lit (See Lighting Instructions)?	Make sure to hold the control knob in for two seconds after snapping the igniter and seeing the orange flame from the burner lighting tube.
	Does the igniter work (Do you see a spark when you repeatedly use the snap igniter)?	Try manually lighting the burner (refer to "Main Burner Manual Lighting"). Call customer service.
<b>Experiencing flare-ups:</b>	Are you preheating barbecue in the prescribed manner?	All burners on HI for 10 to 15 minutes for preheating.
	Are the cooking grates and Flavorizer <sup>®</sup> bars heavily coated with burned-on grease?	Clean thoroughly. (See Section "Cleaning")
	Is the bottom tray "dirty" and not allowing grease to flow into catch pan?	Clean bottom tray.
<b>⚠ CAUTION:</b> Do not line the bottom tray with aluminum foil.		
Burner flame pattern is erratic. Flame is low when burner is on "HI". Flames do not run the whole length of the burner tube.	Are burners clean?	Clean burners. (See Section "Maintenance".)
Inside of lid appears to be "peeling." (Resembles paint peeling.)	The lid is porcelain enamel or stainless steel, not paint. It cannot "peel". What you are seeing is baked on grease that has turned to carbon and is flaking off. <b>THIS IS NOT A DEFECT.</b>	Clean thoroughly. (See Section "Cleaning".)
Cabinet doors are not aligned.	Check the adjustment pin on the bottom of each door.	Loosen adjustment nut/s. Slide door/s until aligned. Tighten nut.

If problems cannot be corrected by using these methods, please contact the Customer Service Representative in your area using the contact information on our web site. Log onto [www.weber.com](http://www.weber.com).



## WEBER® SPIDER/INSECT SCREENS

Your Weber® gas barbecue, as well as any outdoor gas appliance, is a target for spiders and other insects. They can nest in the venturi section (1) of the burner tubes. This blocks the normal gas flow, and can cause the gas to flow back out of the combustion air opening. This could result in a fire in and around the combustion air openings, under the control panel, causing serious damage to your barbecue.

The burner tube combustion air opening is fitted with a stainless steel screen (2) to prevent spiders and other insects access to the burner tubes through the combustion air openings.

We recommend that you inspect the Spider/Insect screens at least once a year. (See Section "Annual Maintenance".) Also inspect and clean the the Spider/Insect screens if any of the following symptoms should ever occur:

- 1) The smell of gas in conjunction with the burner flames appearing yellow and lazy.
- 2) Barbecue does not reach temperature.
- 3) Barbecue heats unevenly.
- 4) One or more of the burners do not ignite.

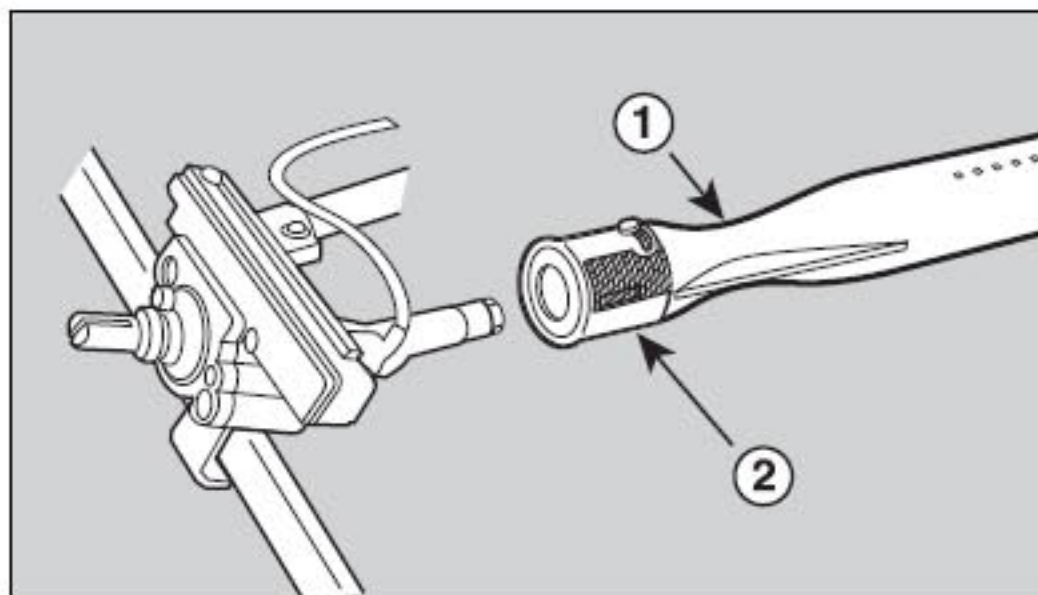

### ⚠ DANGER

Failure to correct the above mentioned symptoms may result in a fire, which can cause serious bodily injury or death, and cause damage to property.

## MAIN BURNER CLEANING PROCEDURE

Turn off the gas supply.

Remove the manifold (See "Replace Main Burners").

Look inside each burner with a flashlight.

Clean the inside of the burners with a wire (a straightened-out coat hanger will work).

Check and clean the air shutter opening at the ends of the burners. Check and clean the valve orifices at the base of the valves. Use a Steel bristle brush to clean outside of burners. This is to make sure all the burner ports are fully open.

⚠ CAUTION: Do not enlarge the burner ports when cleaning.

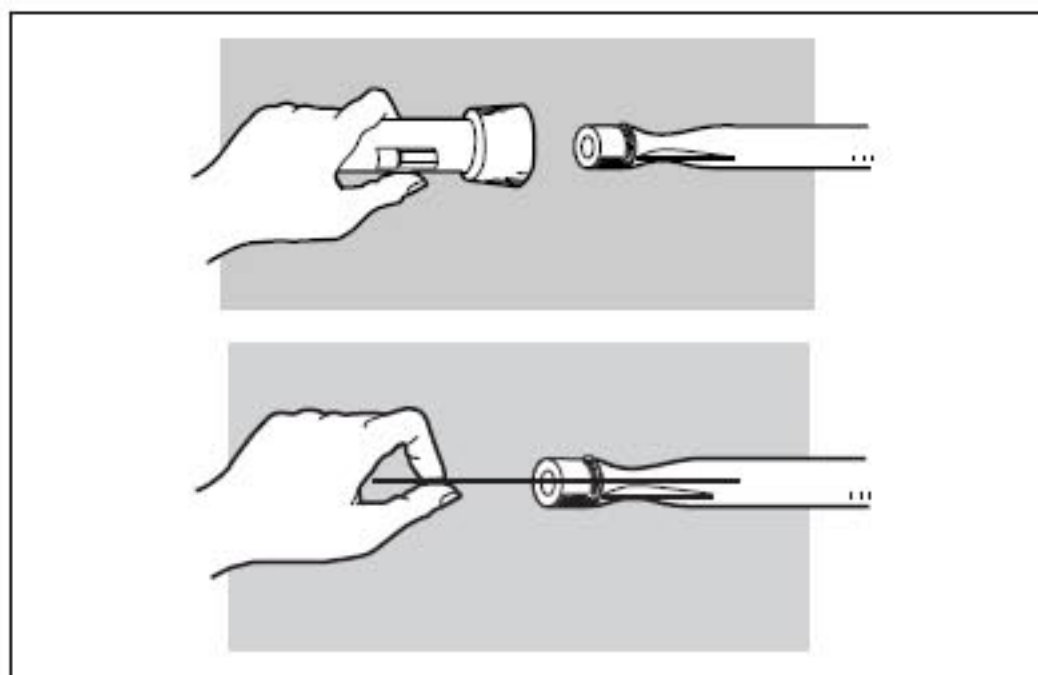

## REPLACE MAIN BURNERS

- 1) Your Summit® gas grill must be off and cool.
- 2) Turn gas off at source.
- 3) Disconnect gas supply.
- 4) Remove cooking grates.
- 5) Remove smoker box.
- 6) Remove Flavorizer® bars.

## REMOVE CONTROL PANEL

- 7) Tool required: Phillips Screwdriver.
  - a) Remove the burner control knobs.
  - b) Remove the two screws that secure the control panel to the frame.
  - c) Remove the control panel. Tilt panel forward and lift up and away from grill. Completely remove the control panel from the cooking box assembly exposing the valves, burners, igniter, and manifold.

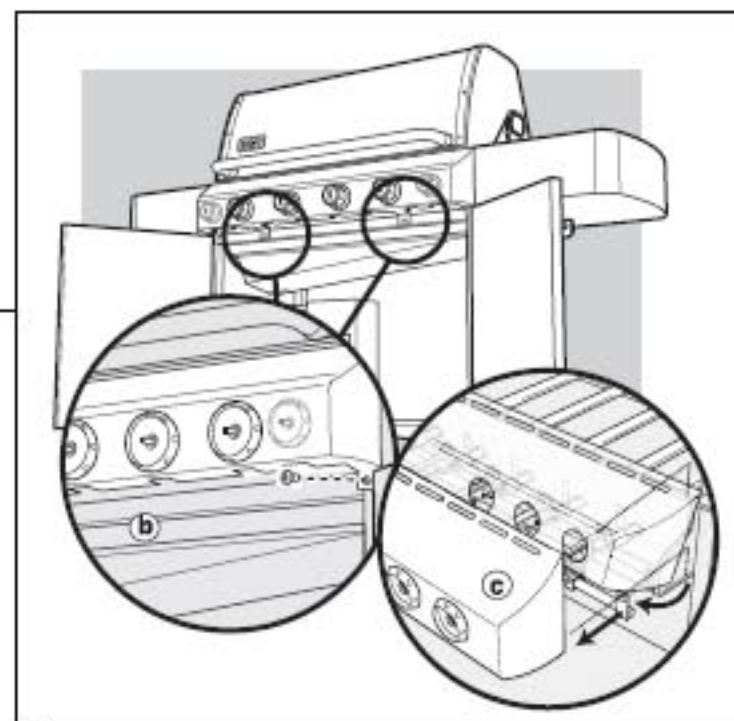
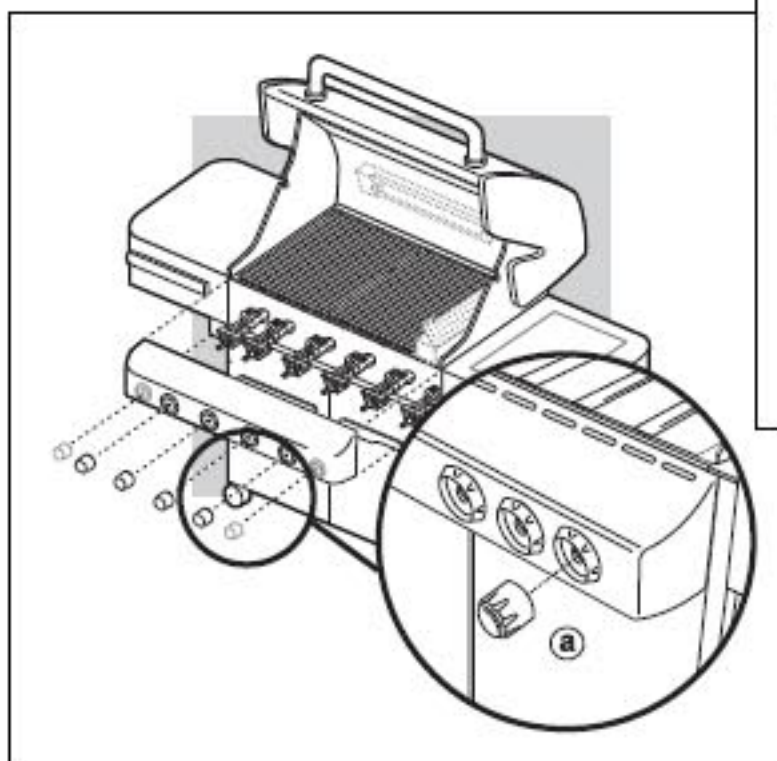



- 8) Remove the two screws that secure the manifold to the cookbox. Pull manifold assembly out from the manifold frame.
- 9) Pull the selected burner(s) tube(s) from manifold frame and replace with a new burner tube.
- 10) To reinstall the manifold assembly, reverse steps 7 through 9.

**⚠ CAUTION:** The burner openings (A) must be positioned properly over the valve orifices (B).

Make sure the opposite end of the burner tubes (C) properly align into the slots on the backside of the cookbox. Check proper assembly before fastening manifold in place.

**⚠ WARNING:** After reinstalling the gas lines, they should be leak checked with a soap and water solution before using the grill. (See, "Check for gas leaks.")

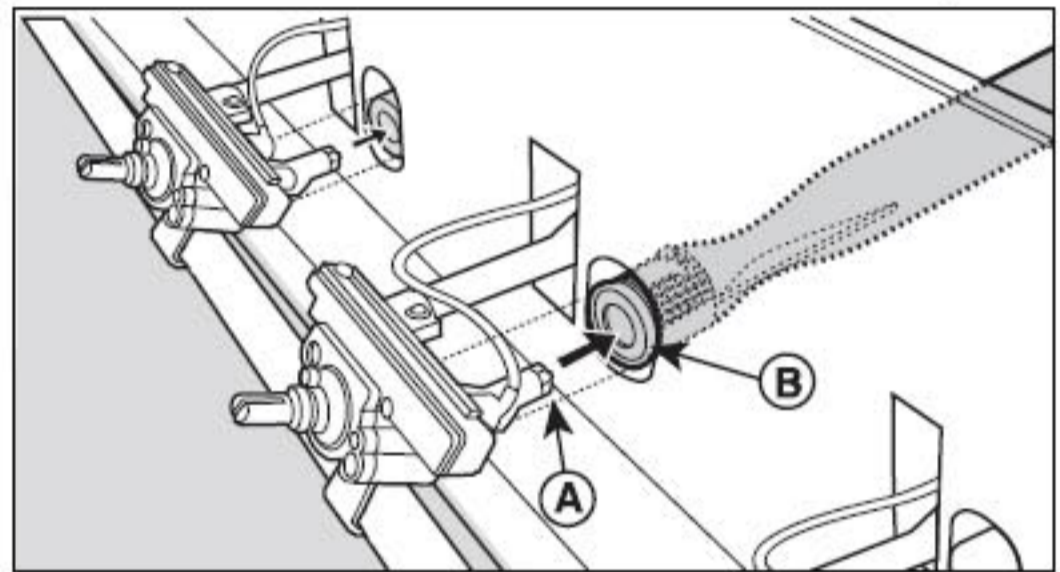
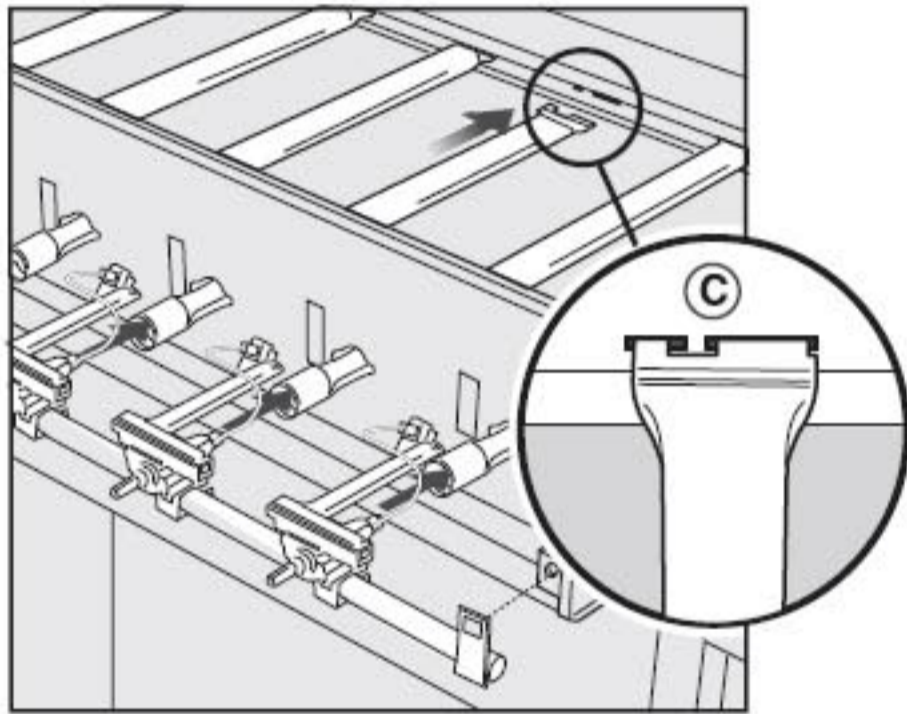
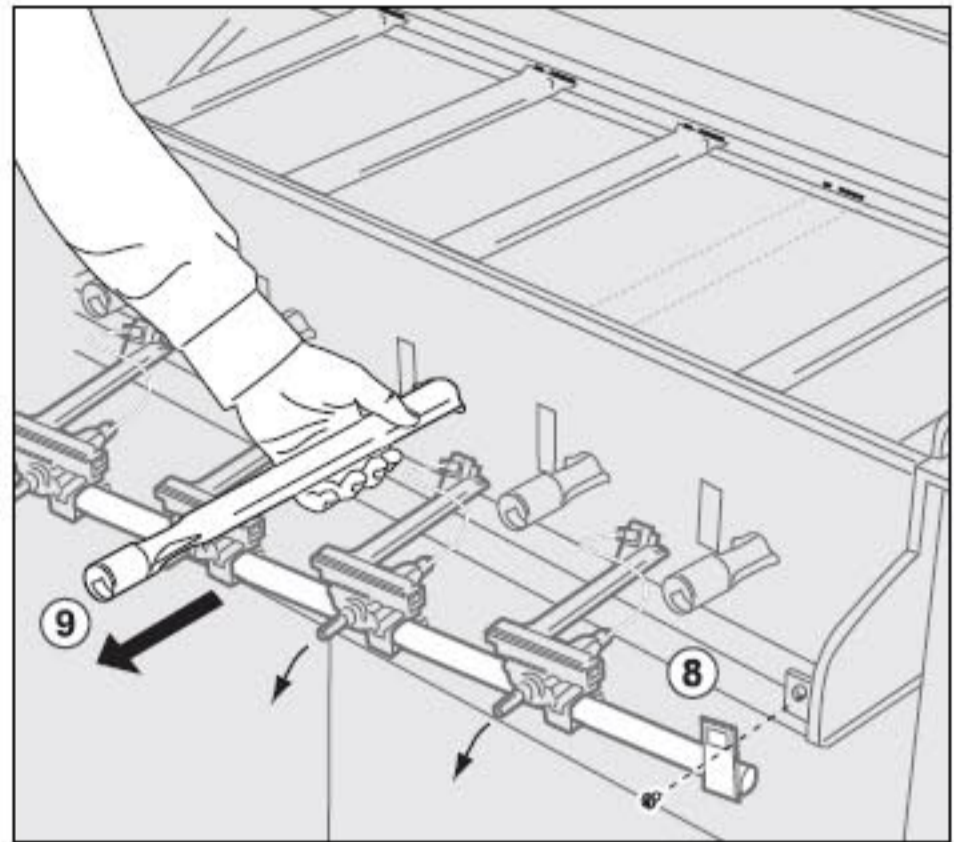

## ANNUAL MAINTENANCE

### INSPECTION AND CLEANING OF THE SPIDER/INSECT SCREENS

To inspect the Spider/Insect screens, remove the control panel. If there is dust or dirt on the screens, remove the burners for cleaning the screens.

Brush the Spider/Insect screens lightly with a soft bristle brush (i.e. an old toothbrush).

**⚠ CAUTION:** Do not clean the Spider/Insect screens with hard or sharp tools. Do not dislodge the Spider/Insect screens or enlarge the screen openings.

Lightly tap the burner to get debris and dirt out of the burner tube. Once the Spider/Insect screens and burners are clean replace the burners.

If the Spider/Insect screen becomes damaged or cannot be cleaned, please contact the Customer Service Representative in your area using the contact information on our web site. Log onto [www.weber.com](http://www.weber.com).

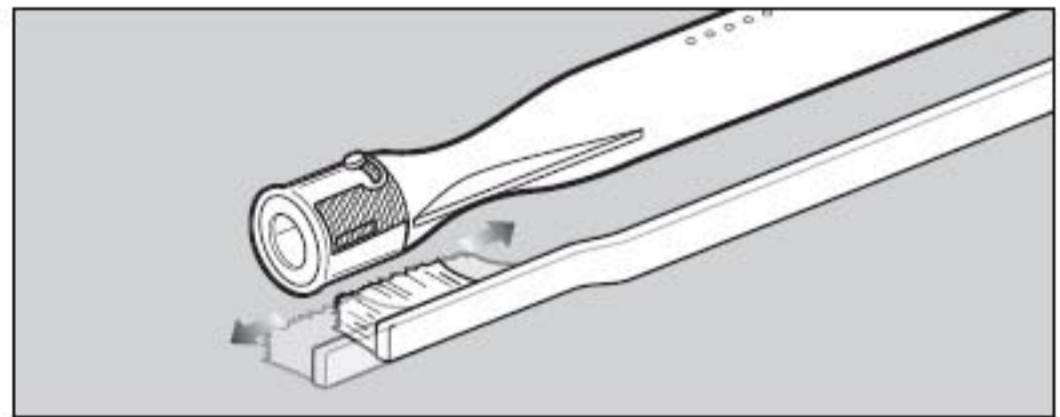

### BURNER FLAME PATTERN

The Weber® gas barbecue burners have been factory set for the correct air and gas mixture. The correct flame pattern is shown.

- 1) Burner tube
- 2) Tips occasionally flicker yellow
- 3) Light blue
- 4) Dark blue

If the flames do not appear to be uniform throughout the burner tube, follow the burner cleaning procedures.

