

This Owner's Manual is provided and hosted by Appliance Factory Parts.

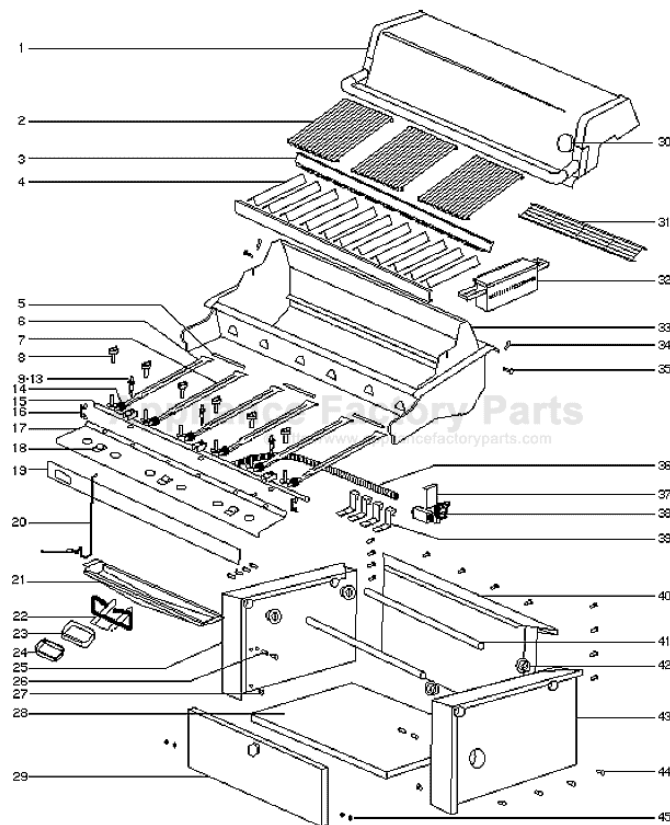

Weber SUMMIT 675 NG Owner's Manual

[Shop genuine replacement parts for Weber SUMMIT
675 NG](#)



[Find Your Weber Grill Parts - Select From 2037 Models](#)

----- Manual continues below -----



SUMMIT™ 475 & 675

Natural Gas Barbecues

Step-By-Step Guide

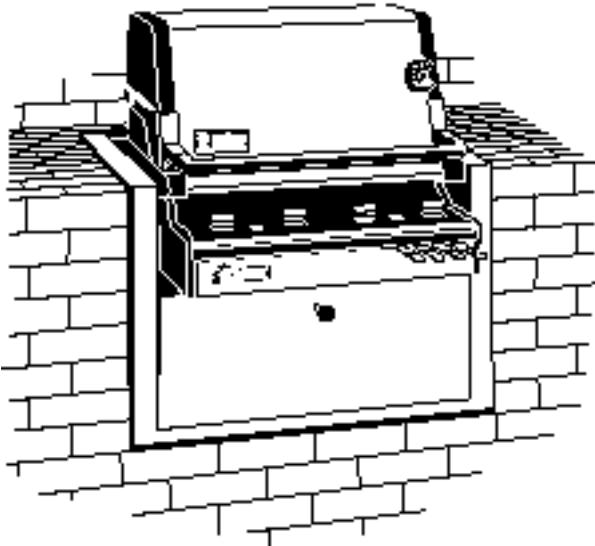

Summit 475 NG

THIS GAS APPLIANCE IS DESIGNED FOR OUTDOOR USE ONLY.

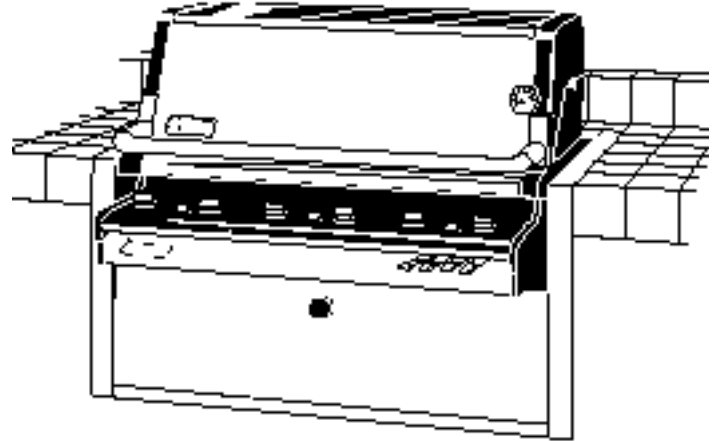

Summit 675 NG

THIS GAS APPLIANCE IS DESIGNED FOR OUTDOOR USE ONLY.

WARNING: Follow all leak check procedures carefully in this manual prior to barbecue operation. Do this even if barbecue was dealer assembled.

NOTICE TO INSTALLER: These instructions must be left with the owner and the owner should keep them for future use.

FOR YOUR SAFETY: Do not store or use gasoline or other flammable vapors and liquids in the vicinity of this or any other appliance.



WARNING: Do not try to light this appliance without reading "Lighting" instructions section of this manual.

THIS GAS APPLIANCE IS DESIGNED FOR OUTDOOR USE ONLY.

FOR YOUR SAFETY

If you smell gas:

1. Shut off gas to the appliance.
2. Extinguish any open flame.
3. Open lid.
4. If odor continues, immediately call your gas supplier or your fire department.

READ CAREFULLY BEFORE INSTALLATION

INSTALL GAS SUPPLY

WE RECOMMEND THAT THIS INSTALLATION BE DONE BY A LICENSED PROFESSIONAL.

General Specifications for Piping

Note - Contact your local municipality for building codes regulating outdoor gas barbecue installations. In absence of Local Codes, you must conform to the latest edition of ANSI Z223.1.

- This barbecue is designed to operate at 4.5 inches of water column pressure. Use only the regulator supplied with the cooking module.
- A manual shut-off valve must be installed outdoors, and be accessible, not in the "built-in" structure. An additional manual shut-off valve indoors should be installed in the branch fuel line in an accessible location near the supply line.

CAUTION: If young children are in the area, a locking valve should be considered.

- Pipe compound should be used which is resistant to the action of natural gas when gas connections are made.
- The gas connections must be firmly attached to rigid, permanent construction.

The information provided in this manual is general for typical installations. We cannot cover all possible installation ideas. We recommend prior to installation that you contact your municipality for local building codes and your local fire department for installation verification. You can also call Weber-Stephen Products Co. at 1-888-33SUMMIT (1-888-337-8664) and we will try and answer any questions you may have.

Gas line piping

- If the length of line required does not exceed 50 feet, use a 5/8" O.D. tube. One size larger should be used for lengths greater than 50 feet.
- Gas piping may be copper tubing, type K or L; polyethylene plastic tube, with a minimum wall thickness of .062 inch; or standard weight (schedule 40) steel or wrought iron pipe.
- Copper tubing must be tin-lined if the gas contains more than 0.3 grams of hydrogen sulfide per 100 cubic feet of gas.
- Plastic tubing is suitable only for outdoor, underground use.
- Gas piping in contact with earth, or any other material which may corrode the piping, must be protected against corrosion in an approved manner.
- Underground piping must have a minimum of 18" cover.

Test connections

All connections and joints must be thoroughly tested for leaks in accordance with local codes and all listed procedures in the latest edition of ANSI Z223.1.

DANGER

Do not use an open flame to check for gas leaks. Be sure there are no sparks or open flames in the area while you check for gas leaks. This will result in a fire or explosion which can cause serious bodily injury or death, and damage to property.

If you have any questions, contact the Weber-Stephen Customer Service Center at 1-888-33-SUMMIT (1-888-337-8664).

BUILT-IN CONSTRUCTION GENERAL INFORMATION

WARNING

A Weber-Stephen Products Co. insulated sleeve must be used for any built-in installation.

LOCATING YOUR BARBECUE

When determining a suitable location for your barbecue installation, give attention to concerns such as exposure to wind, proximity to traffic paths, and keeping any gas supply lines as short as possible. Never locate the Weber Gas Barbecue in a garage, breezeway, shed, under an unprotected overhang, or other enclosed area. Locate the barbecue and structure so there is enough room to safely evacuate the area in case of a fire.

CLEARANCE FROM NON-COMBUSTIBLE SURFACES OR STRUCTURES

Warning: Clearance from the outside walls of the sides and back of the insulated sleeve must be a minimum of 6 inches from a non-combustible surface. Measure from the outside wall of the insulated surface to the non-combustible surface. Figure 1. Refer to "Install Gas Supply" on page 2 before starting installation.

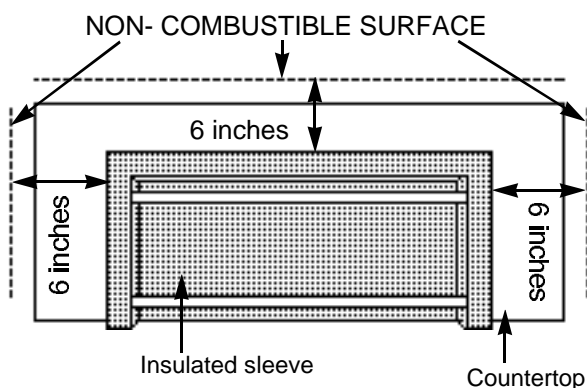

Figure 1

WARNING: All countertop finished surfaces must be constructed of a noncombustible material.

CLEARANCE FROM COMBUSTIBLE SURFACES OR STRUCTURES

Warning: Clearance from the outside walls of the sides and back of the insulated sleeve must be a minimum of 24 inches from a combustible surface. Measure from the outside wall of the insulated surface to the combustible surface. Figure 2. Refer to "Install Gas Supply" on page 2 before starting installation.

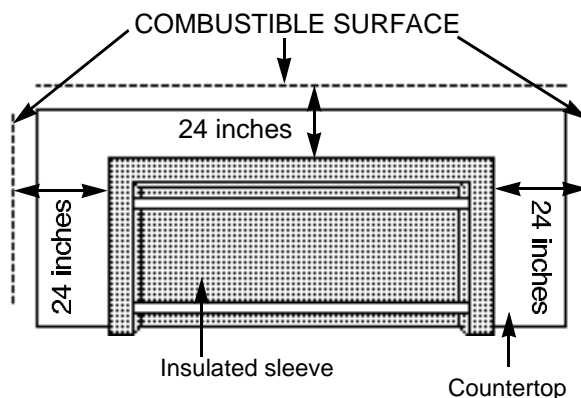

Figure 2

WARNING: All countertop finished surfaces must be constructed of a noncombustible material.

BUILT-IN STRUCTURE CUTOUT DIMENSIONS

All dimensions are to finished surfaces.

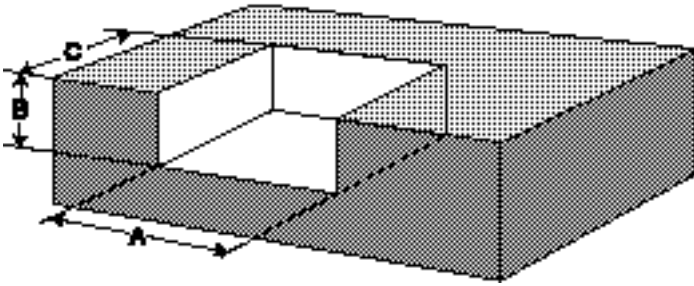

Figure 3

BUILT-IN CUTOUT DIMENSIONS

DIMENSIONS	475	675	Side Burner	Tolerances
	A	31 $\frac{5}{8}$ "	43 $\frac{5}{8}$ "	10 $\frac{3}{4}$ "
B	21 $\frac{1}{8}$ "	21 $\frac{1}{8}$ "	4 $\frac{1}{2}$ "	+ $\frac{3}{32}$ " - 0
C	25"	25"	24"	+ $\frac{3}{16}$ " - 0
WT	240	285	40	

Weight (expressed in pounds) represents the total weight of the insulated sleeve and the cooking unit and does not include the permanent structure housing the sleeve.

The sleeve must be supported from the bottom.

Recommended cutout dimensions "A through C" include a nominal clearance dimension to facilitate installation. Any additional clearance must be within tolerances shown or fit-up of sleeve and built-in structure may be adversely affected.

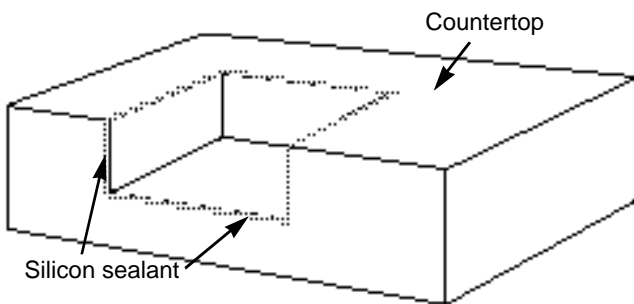

Figure 4

Before installing the sleeve, lay a bead of silicon sealant around the top perimeter and front sides of the structure in the areas that the flanges of the sleeve will rest. This will prevent moisture seepage. The sealant you use must have a temperature rating above 120°F. If necessary, caulk between the flange of the sleeve and finished countertop surface.

WARNING: All countertop finished surfaces must be constructed of a noncombustible material.

BUILT-IN STRUCTURE SLEEVE DIMENSIONS

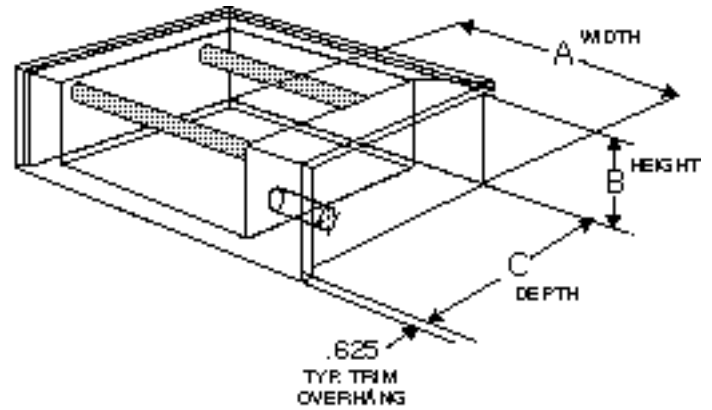

Figure 5

BUILT-IN INSULATED SLEEVE DIMENSIONS

DIMENSIONS	475	675	Tolerances
	A	31 $\frac{1}{2}$ "	43 $\frac{1}{2}$ "
B	21 $\frac{1}{8}$ "	21 $\frac{1}{8}$ "	+ $\frac{3}{16}$ " - 0
C	24 $\frac{1}{8}$ "	24 $\frac{1}{8}$ "	+ $\frac{3}{8}$ " - 0
WT	240	285	

Weight (expressed in pounds) represents the total weight of the insulated sleeve and the cooking unit and does not include the permanent structure housing the sleeve.

Specified insulated sleeve dimensions "A through C" reflect the dimension to the mounting surface of the trim excluding the .625 trim overhang.

If the supporting structure is going to have an electrical outlet for a rotisserie, it should be on the left side of the structure.

WARNING: Air holes must be provided in the structure at the top and bottom to provide ventilation in the event of a gas leak.

Air holes can be located in a low visibility area and should be protected by screening material to prevent rodents and insects from entering the structure. Air holes will also help dry moisture.

BUILT-IN SLEEVE GAS LINE LOCATIONS

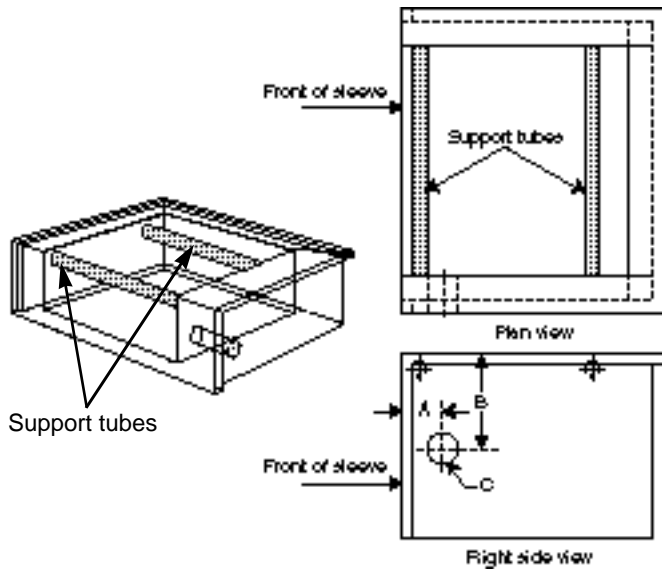

Figure 6

BUILT-IN SLEEVE GAS LINE LOCATIONS

	475	675	Tolerances	
DIMENSIONS	A	5.0"	5.0"	+ $\frac{1}{16}$ - $\frac{1}{16}$
	B	10.1"	10.1"	+ $\frac{1}{16}$ - $\frac{1}{16}$
	C	2.5"	2.5"	+ $\frac{1}{32}$ - $\frac{1}{32}$

The dimensions shown indicate the location of the gas line inlet flange in the insulated sleeve. The support members of the built-in structure must not impede passage of the gas lines.

Area should be kept clear of sharp, jagged, or extremely abrasive surfaces to avoid possible damage to gas supply lines. Exercise caution when pulling gas lines through built-in structure.

Note: Leave an access in the structure for gas supply and regulator service.

SUPPLIES NEEDED

You will need a soap and water solution to check for gas leaks. (See Step "Check for gas leaks.")

Note - The hardware size of nuts, bolts and screws is given. For example "1/4-20 x 2 inch bolt" means a bolt 1/4 inch in diameter with 20 threads to the inch, 2 inches long. On a small screw for example, "6-32 x 1/2 inch screw" means a number 6 screw, with 32 threads to the inch, 1/2 inch long.

While we give much attention to our products, unfortunately an occasional error may occur. If a part is missing, do not go back to the store. Call the Weber Customer Service Center toll free **1-888-33-SUMMIT** (1-888-337-8664) to receive immediate assistance. Have your owner's manual and serial number of the barbecue available for reference.

REMOVE PACKAGED CONTENTS

Flavorizer bar
(7) (Summit 475)
(11) (Summit 675)



Optional Steam-N-Chips smoker

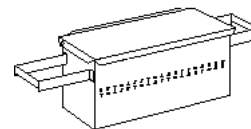

Cooking grate
(2) (Summit 475)
(3) (Summit 675)



Warm-up basket



Burner control knob
(4) (Summit 475)
(6) (Summit 675)

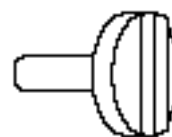

Bottom tray

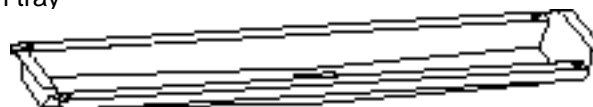

Catch pan holder



Catch pan



Drip pan

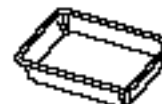

Tool holder (4)

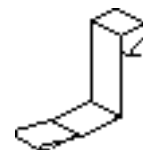

Regulator/Bracket

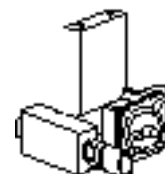

Corrugated Hose



ADD COOKING MODULE

Caution: Use two people to lift and install the cooking module.

Lift the cooking module out of the packaging. The gas line will hang below the module.

Lower the module on an angle into the sleeve so the control panel is under the front top rail. Figure 7. Guide the gas line through the access hole in the sleeve while lowering the module.

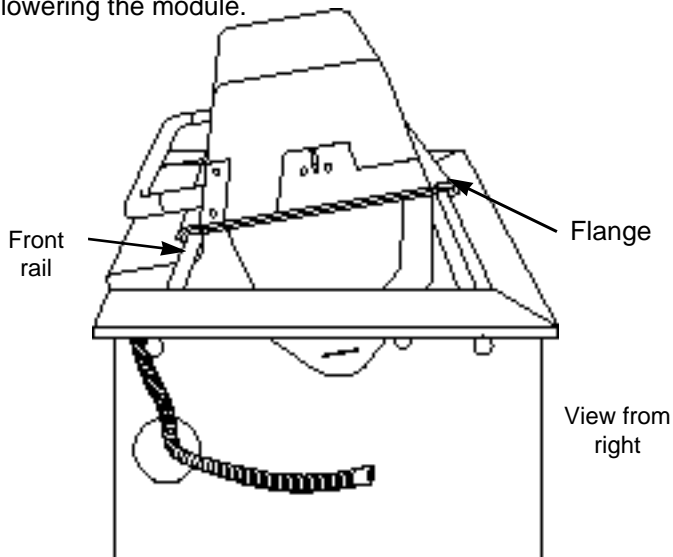

Figure 7

Lower the back of the cooking module down so it sets on the rear rail. Figure 8. Be careful not to scratch the paint of the cooking module when installing the module.

The cooking module should be level, setting on the front and rear rails.

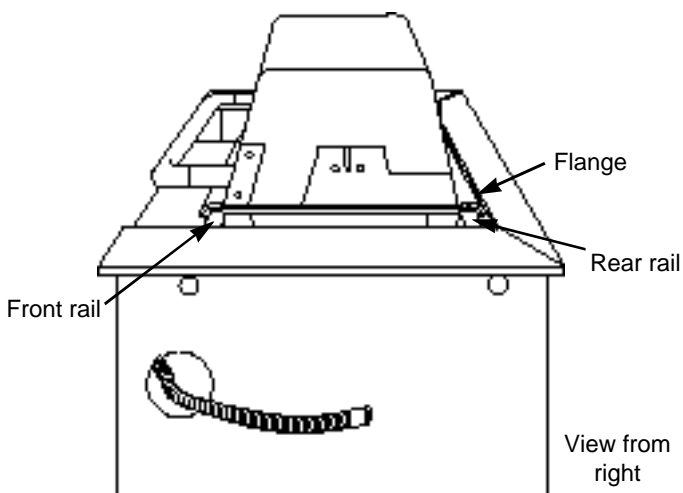

Figure 8

MOUNT REGULATOR BRACKET

We recommend that you install the regulator to a rigid structure. The regulator mounting bracket can be used to mount the regulator to the built-in structure.

The gas line from the manifold is long enough to reach the mounted regulator. We have provided the means to make an SAE flare connection. Do not use pipe sealant on this connection.

CONNECT GAS SUPPLY TO REGULATOR

Hard pipe the gas supply to the inlet of the regulator. Refer to "Install Gas Supply" section on page 2.

Connect the corrugated gas line to the regulator. Figure 9. Figure 10 shows the gas line and regulator assembled. Hard pipe the gas supply to the regulator. Figure 11.

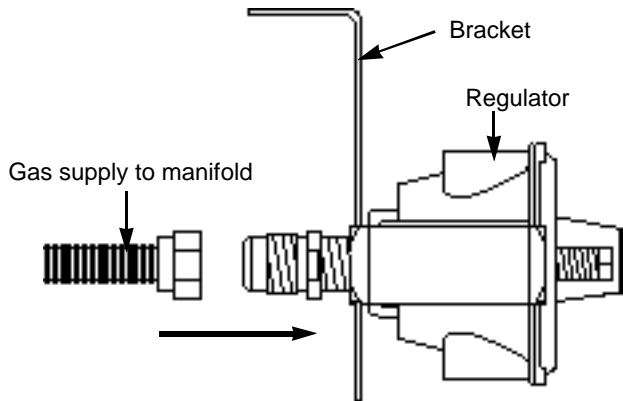

Figure 9

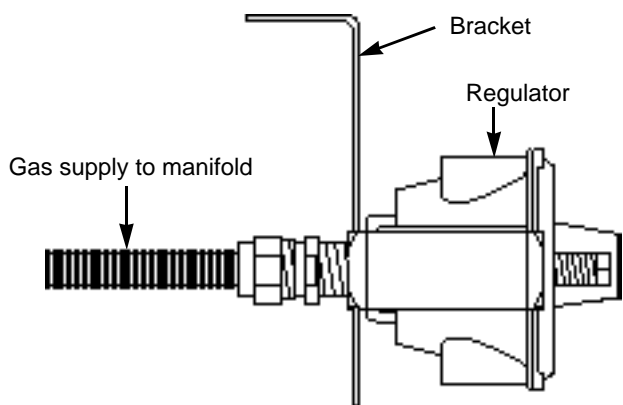

Figure 10

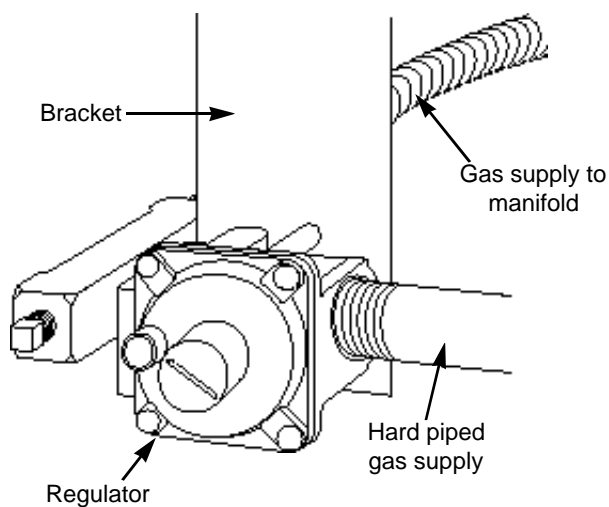
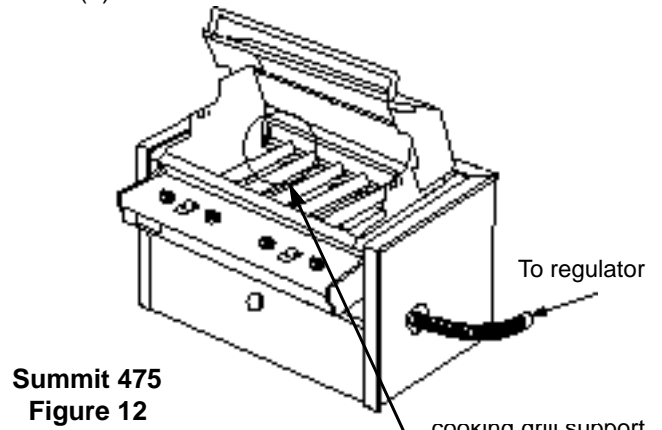

Figure 11

INSTALL FLAVORIZER BARS

You will need: seven (Summit 475) or eleven (Summit 675) flavorizer bars

Set the Flavorizer bars front to back over the burners in the slots of the Flavorizer Bar/cooking grill support. Figure 12 (a).



**Summit 475
Figure 12**

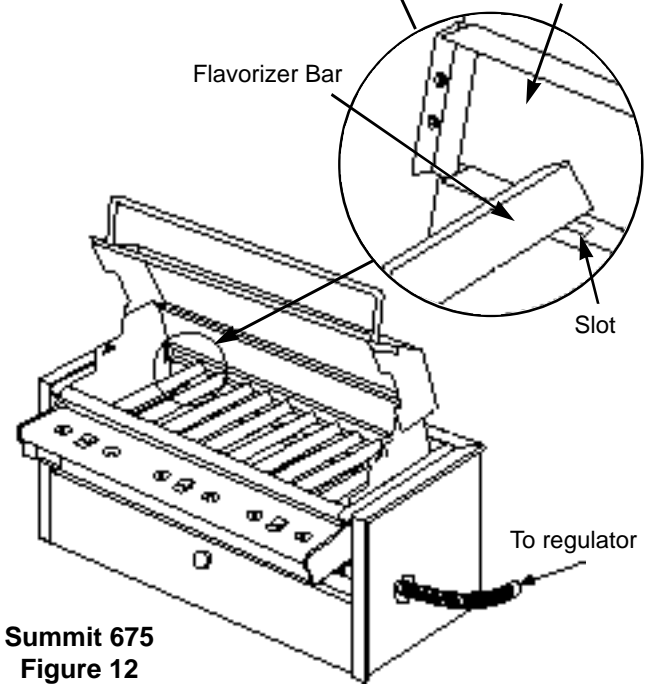

**Summit 675
Figure 12**

INSTALL STEAM-N-CHIPS SMOKER

You will need: Steam-N-Chips smoker.

Remove the center Flavorizer bar (the one that is not over a burner). Set the handles of the Steam-N-Chips smoker on the Flavorizer bar holder. Figure 13 (a).

Note: For directions on how to use the Steam-N-Chips smoker, see the Operating Guide.

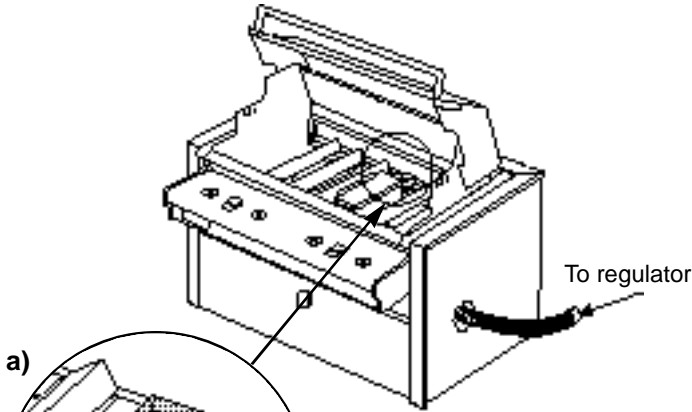

**Summit 475
Figure 13**

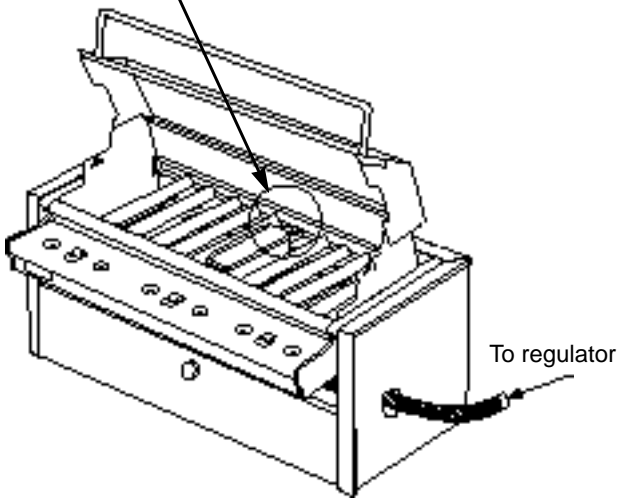
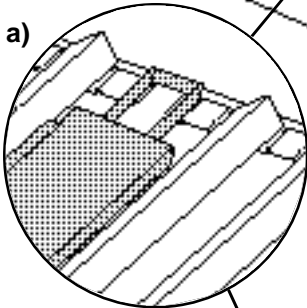

**Summit 675
Figure 13**

ADD COOKING GRATES

You will need: two (Summit 475) or three (Summit 675) cooking grates.

The cross-wire of the cooking grate goes down. Set the cooking grates in place next to each other. Figure 14.

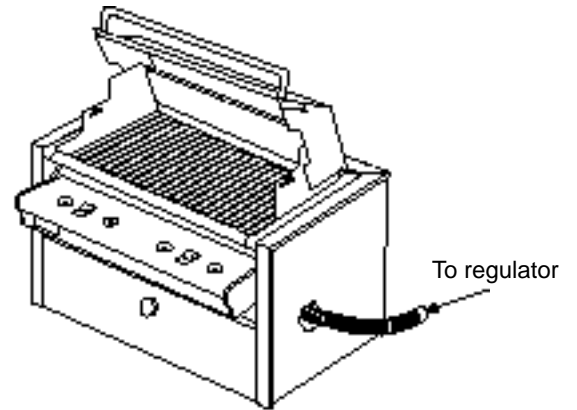

Figure 14

INSTALL WARM-UP BASKET

You will need: warm-up basket.

Install one end of the warm-up basket into the hole on the right end of the lid and the other end into the slot in the left end of the lid. Figure 15 (a).

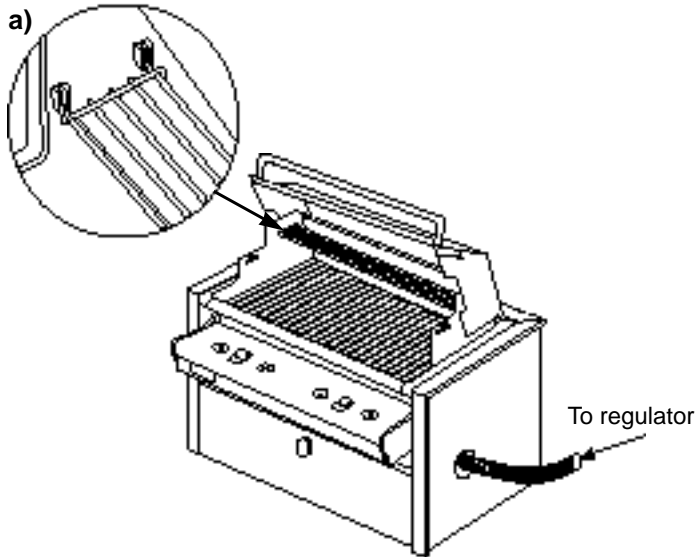

Figure 15

INSTALL BURNER CONTROL KNOBS

You will need: four (Summit 475) or six (Summit 675) burner control knobs.

Push on the burner control knobs. Figure 16.

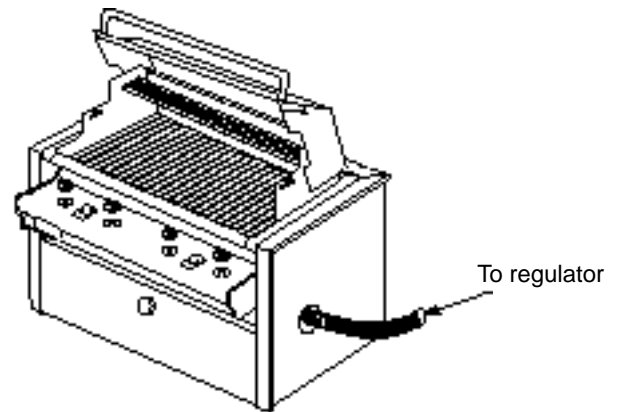

Figure 16

INSTALL BOTTOM TRAY

You will need: Bottom tray, catch pan holder, catch pan, and one drip pan.

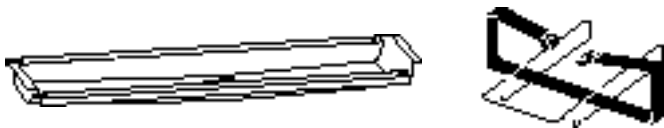

Figure 17

Note: It may be easier to install the catch pan holder by removing the catch pan from the holder.

Hook the ends of the catch pan holder into the hole in the bottom tray. Figure 18.

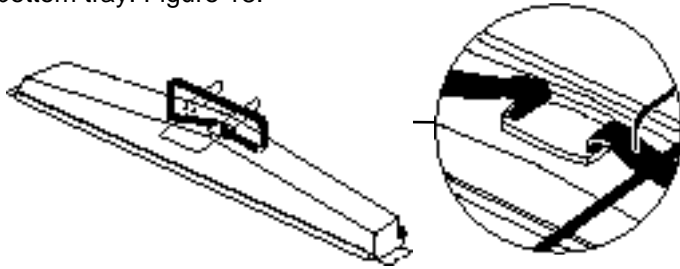

Figure 18

Slide the bottom tray into the mounting slots under the bottom of the cooking box with the finger grip of the catch pan toward you. Figure 19.

CAUTION: Do not line the bottom tray with aluminum foil. It can cause grease fires by trapping the grease and not allowing grease to flow into the catch pan.

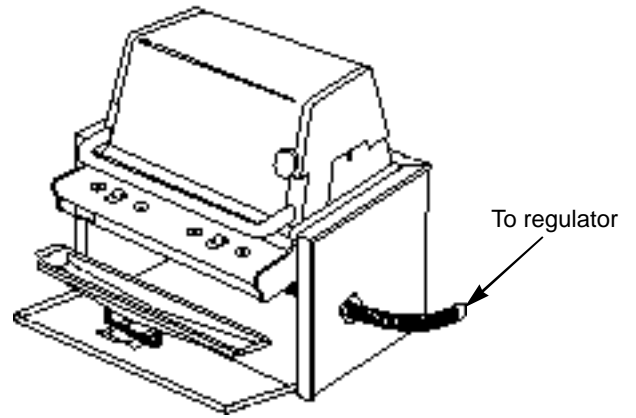

Figure 19

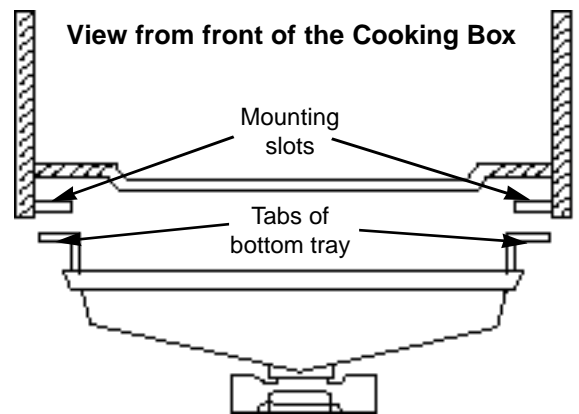

Figure 20

Put the foil drip pan into the catch pan.

CHECK FOR GAS LEAKS

WARNING

The gas connections of your Weber Gas Barbecue have been factory tested. We do however recommend that you leak check all gas connections before operating your Weber Gas Barbecue.

Remove control panel burner control knobs, and front panel

The control panel is separate from the front panel. The control panel needs to be removed before the front panel can be removed. Figure 21.

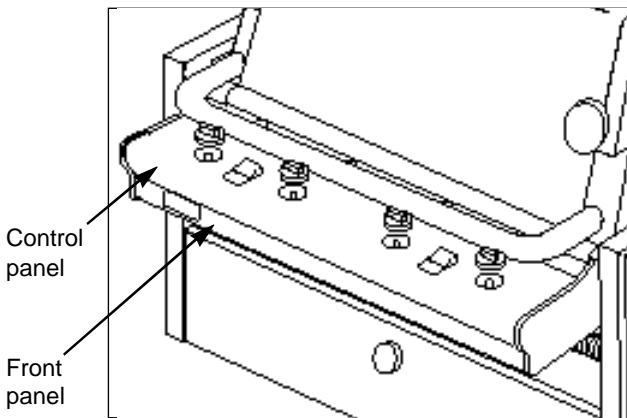

Figure 21

Put your fingers under the front edge of the control panel, lift up, and pull evenly toward you. Figure 22 (a).

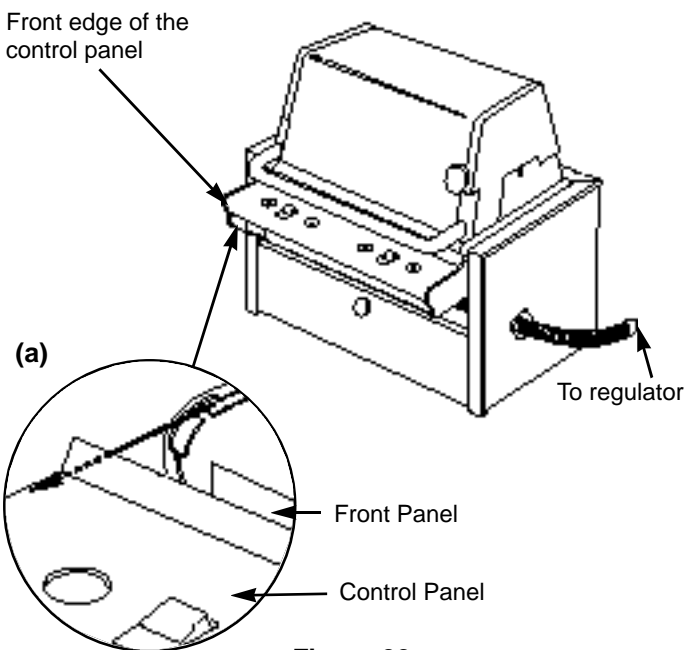

Figure 22

Pull the front panel up and out of the cooking box assembly. Figure 23.

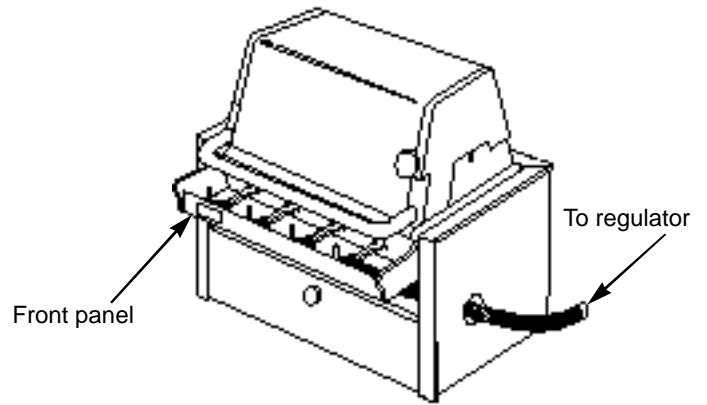

Figure 23

DANGER

Do not use an open flame to check for gas leaks. Be sure there are no sparks or open flames in the area while you check for leaks. This will result in a fire or explosion which can cause serious bodily injury or death and damage to property.

WARNING: You should check for gas leaks every time you disconnect and reconnect a gas fitting.

You will need: a soap and water solution and a rag or brush to apply it.

Note: Since some leak test solutions, including soap and water, may be slightly corrosive, all connections should be rinsed with water after checking for leaks.

Warning: Make sure all burner control knobs are in the OFF position, including the side burner, if the barbecue has a side burner.

Turn on gas supply.

CHECK FOR GAS LEAKS

Check for leaks by wetting the connections with the soap and water solution and watching for bubbles. If bubbles form or if a bubble grows there is a leak.

Note - Since some leak test solutions, including soap and water, may be slightly corrosive, all connections should be rinsed with water after checking for leaks.

WARNING: Do not ignite burners when leak checking.

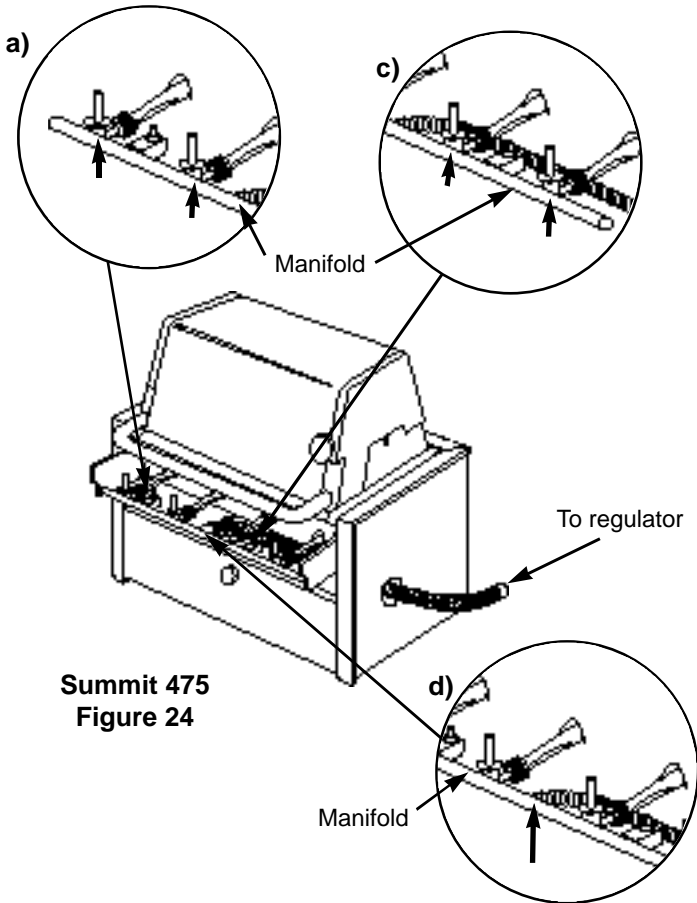

Summit 475
Figure 24

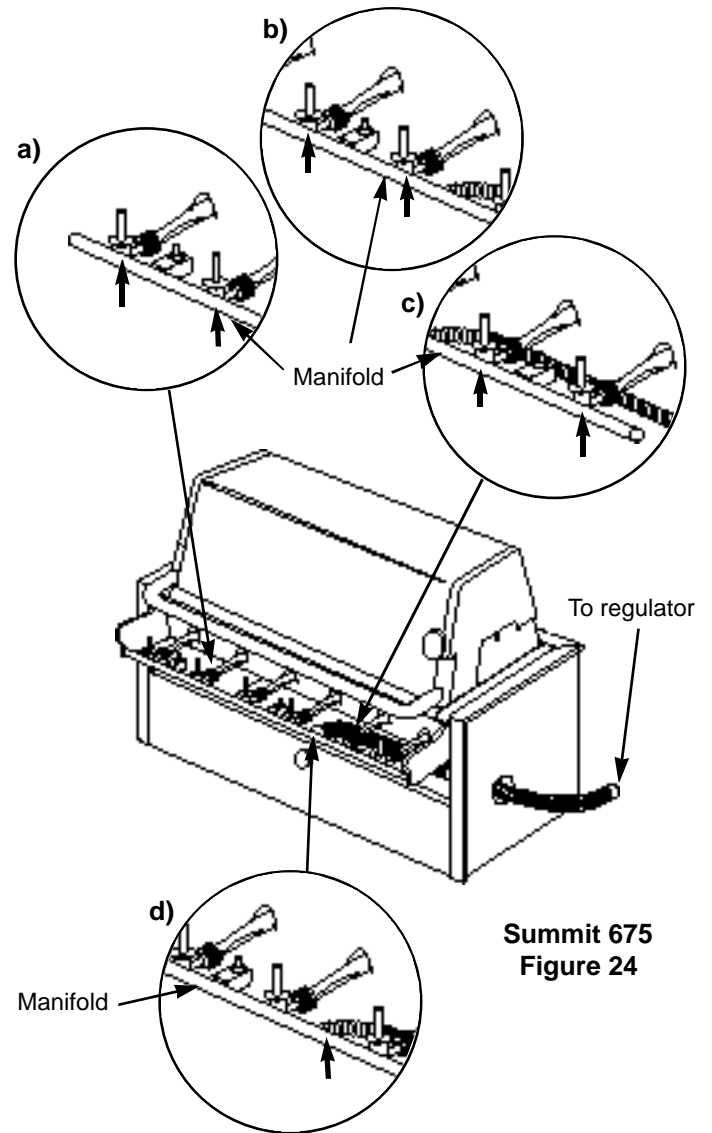

Summit 675
Figure 24

Check:

- Left valves to manifold connection. Figure 24 (a).
- Center valves to manifold connection. Figure 24 (b). (For Summit 675 only.)
- Right valves to manifold connection. Figure 24 (c).
- Gas line to manifold connection. Figure 24 (d)
- Leak check all gas supply connections.

WARNING: If there is a leak at connection 24 (d), turn OFF the gas and retighten the fitting with a wrench and recheck for leaks with soap and water solution.

If a leak persists after retightening the fitting, turn OFF the gas. **DO NOT OPERATE THE BARBECUE.** Contact your dealer.

WARNING: If there is a leak at connections 24 (a), 24 (b), or 24 (c) turn OFF the gas. Do not operate the barbecue. Contact your dealer.

When leak checks are complete, turn gas supply OFF at the source and rinse connections with water.

REINSTALL FRONT PANEL

You will need: front panel.

With the Weber logo to the left, slide front panel down into place. Figure 25.

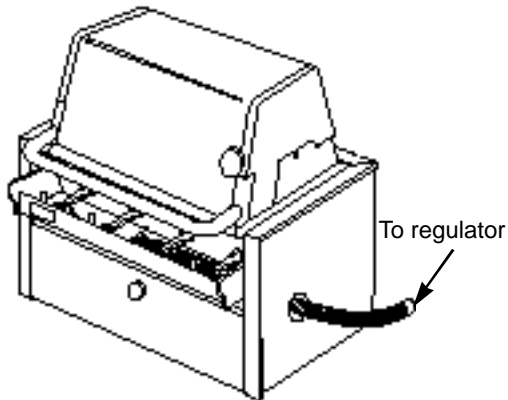

Figure 25

REINSTALL CONTROL PANEL

You will need: control panel.

Pull igniter buttons up until they stay in the up position. Place the control panel into the grooves on either side of the front of the cooking box. Push the control panel into place, using even pressure while pushing. Figure 26 (a).

Use your fingers to lift the front edge of the control panel slightly and set it into the recess on both sides of the cooking box. Figure 26.

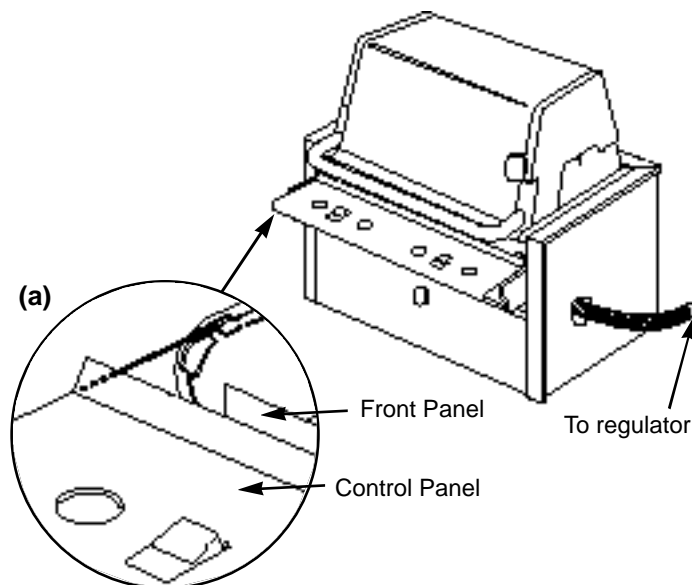

Figure 26

REINSTALL BURNER CONTROL KNOBS

You will need: four (Summit 475) or six (Summit 675) burner control knobs.

Push on the burner control knobs. Figure 27.

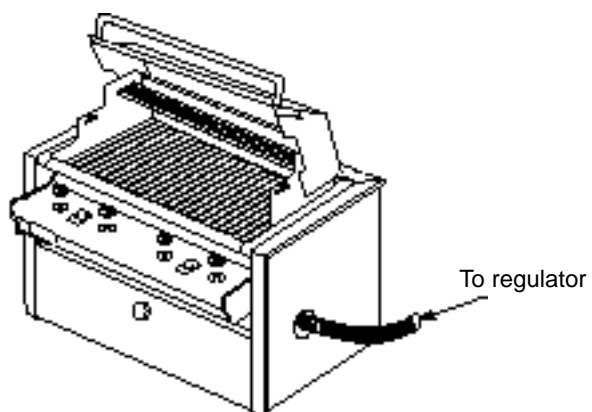

Figure 27

INSTALL TOOL HOLDERS

You will need: four tool holders.

Place the tool holder under the control panel and over the front panel on the right side. Figure 28 (a). Set the tool holder on top of the front panel and slide it to the left.

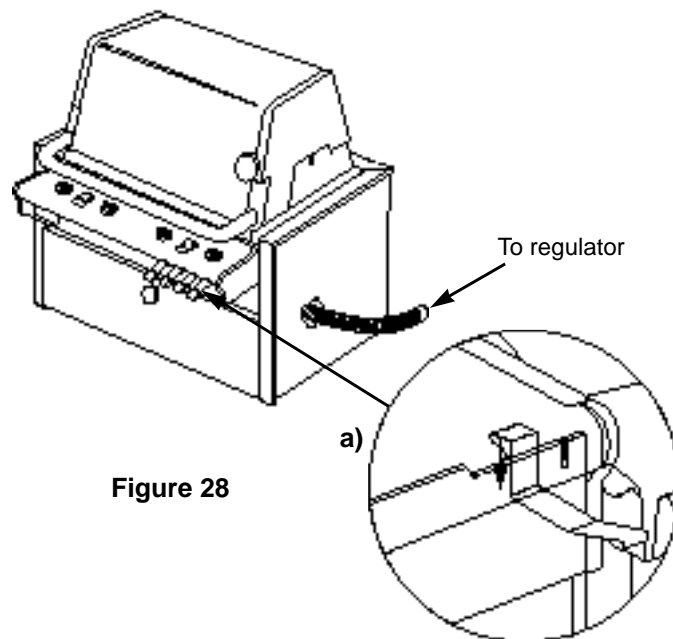

Figure 28

REFER TO OPERATING GUIDE BEFORE LIGHTING BARBECUE

