



SUMMIT[®] Silver A & Gold A

Natural Gas Grill Owners Guide

**YOU MUST READ THIS OWNERS GUIDE
BEFORE OPERATING YOUR GAS GRILL**

#

42095

⚠ DANGER

If you smell gas:

1. Shut off gas to the appliance.
2. Extinguish any open flames.
3. Open lid
4. If odor continues, keep away from the appliance and immediately call your gas supplier or your fire department.

Leaking gas may cause a fire or explosion which can cause serious bodily injury or death, or damage to property.

⚠ WARNING

1. Do not store spare liquid propane cylinder within 10 feet (3m) of this appliance.
2. Do not store or use gasoline or other flammable liquids or vapors within 25 feet (8m) of this appliance.

⚠ WARNING: Follow all leak-check procedures carefully in this manual prior to barbecue operation. Do this even if the barbecue was dealer-assembled.

NOTICE TO INSTALLER: These instructions must be left with the owner and the owner should keep them for future use.

THIS GAS APPLIANCE IS DESIGNED FOR OUTDOOR USE ONLY.

⚠ WARNING: Do not try to light this appliance without reading the "Lighting" Instructions section of this manual

A403_NG.f
 Ba402_NG.b
 B403_NG.b
 C402_NG.d
 D402_NG.d
 E402.c



**42095 US 05/09/03
NG**

⚠ Dangers & ⚠ Warnings

⚠ DANGER

Failure to follow the Dangers, Warnings and Cautions contained in this Owner's Manual may result in serious bodily injury or death, or in a fire or an explosion causing damage to property.









⚠ WARNINGS

- ⚠ Do not store a spare or disconnected liquid propane cylinder under or near this barbecue.
- ⚠ Improper assembly may be dangerous. Please carefully follow the assembly instructions in this manual.
- ⚠ After a period of storage, and/or nonuse, the Weber® gas barbecue should be checked for gas leaks and burner obstructions before use. See instructions in this manual for correct procedures.
- ⚠ Do not operate the Weber® gas barbecue if there is a gas leak present.
- ⚠ Do not use a flame to check for gas leaks.
- ⚠ Combustible materials should never be within 24 inches of the top, bottom, back or sides of your Weber® gas barbecue.
- ⚠ Do not put a barbecue cover or anything flammable on, or in the storage area under the barbecue.
- ⚠ Your Weber® gas barbecue should never be used by children. Accessible parts of the barbecue may be very hot. Keep young children away while it is in use.
- ⚠ You should exercise reasonable care when operating your Weber® gas barbecue. It will be hot during cooking or cleaning and should never be left unattended, or moved while in operation.
- ⚠ Should the burners go out while in operation, turn all gas valves off. Open the lid and wait five minutes before attempting to relight, using the lighting instructions.
- ⚠ Do not use charcoal or lava rock in your Weber® gas barbecue.
- ⚠ Never lean over open grill or place hands or fingers on the front edge of the cooking box.
- ⚠ Should a grease fire occur, turn off all burners and leave lid closed until fire is out.
- ⚠ Do not enlarge valve orifices or burner ports when cleaning the valves or burners.
- ⚠ The Weber® gas barbecue should be thoroughly cleaned on a regular basis.
- ⚠ Liquid propane gas is not natural gas. The conversion or attempted use of natural gas in a liquid propane unit or liquid propane gas in a natural gas unit is dangerous and will void your warranty.
- ⚠ Do not attempt to disconnect any gas fitting while your barbecue is in operation.
- ⚠ Use heat-resistant barbecue mitts or gloves when operating barbecue.
- ⚠ Keep any electrical supply cord and the fuel supply hose away from any heated surfaces.
- ⚠ Combustion byproducts produced when using this product contain chemicals known to the state of California to cause cancer, birth defects, or other reproductive harm.
- ⚠ Do not use this barbecue unless all parts are in place. The unit must be properly assembled according to the instructions outlined in the "Assembly Instruction" section of the Owner's Guide.

LIQUID PROPANE GAS UNITS ONLY:

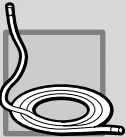
- ⚠ Use the regulator that is supplied with your Weber® gas barbecue.
- ⚠ Do not attempt to disconnect the gas regulator or any gas fitting while your barbecue is in operation.
- ⚠ A dented or rusty liquid propane cylinder may be hazardous and should be checked by your liquid propane supplier. Do not use a liquid propane cylinder with a damaged valve.
- ⚠ Although your liquid propane cylinder may appear to be empty, gas may still be present, and the cylinder should be transported and stored accordingly.
- ⚠ If you see, smell or hear the hiss of escaping gas from the liquid propane cylinder:
 1. Move away from liquid propane cylinder.
 2. Do not attempt to correct the problem yourself.
 3. Call your fire department.

Contents

	Danger & Warnings	A-2
	Warranty	A-4
	General Instructions	A-5
	Grilling Methods	A-6
	Cleaning	A-6
	Exploded Views	A-7
	Parts List	A-11
	Assembly Instructions	B-a
	Gas Instructions	C-1
	Leak Checking	C-4
	Operating	D-1
	Grilling Methods	D-1
	Lighting	D-3
	Manual Lighting	D4
	Troubleshooting	D-5
	Maintenance	E-1
	Replacing Main Burners	E-2
	Crossover® Ignition System Operations	E-5

Warranty

Weber-Stephen Products Co. (Weber) hereby warrants to the ORIGINAL PURCHASER of this Weber® gas grill that it will be free of defects in material and workmanship from the date of purchase as follows:

Aluminum Castings, lifetime,	1 year paint
Stainless Steel Hood Section,	25 years
Burners,	10 years
Igniter,	3 years
Cooking Grates,	7 years
Flavorizer® Bars,	5 year no rust through
Thermoplastic/Thermoset Parts,	10 years Excluding fading
All Remaining Parts,	5 years,

when assembled and operated in accordance with the printed instructions accompanying it.

Weber may require reasonable proof of your date of purchase. THEREFORE, YOU SHOULD RETAIN YOUR SALES SLIP OR INVOICE.

This Limited Warranty shall be limited to the repair or replacement of parts that prove defective under normal use and service and which on examination shall indicate, to Weber's satisfaction, they are defective. Before returning any parts, contact the Customer service representative in your region using the contact information sheet provided with your manual. If Weber® confirms the defect and approves the claim, Weber® will elect to replace such parts without charge. If you are required to return defective parts, transportation charges must be prepaid. Weber® will return parts to the purchaser, freight or postage prepaid.

This Limited Warranty does not cover any failures or operating difficulties due to accident, abuse, misuse, alteration, misapplication, vandalism, improper installation or improper maintenance or service, or failure to perform normal and routine maintenance, including but not limited to damage caused by insects within the burner tubes, as set out in this owner's manual.

Deterioration or damage due to severe weather conditions such as hail, hurricanes, earthquakes or tornadoes, discoloration due to exposure to chemicals either directly or in the atmosphere, is not covered by this Limited Warranty.

There are no other express warrants except as set forth herein and any applicable implied warranties of merchantability and fitness are limited in duration to the period of coverage of this express written Limited Warranty. Some regions do not allow limitation on how long an implied warranty lasts, so this limitation may not apply to you.

Weber® is not liable for any special, indirect or consequential damages. Some regions do not allow the exclusion or limitation of incidental or consequential damages, so this limitation or exclusion may not apply to you.

Weber® does not authorize any person or company to assume for it any other obligation or liability in connection with the sale, installation, use, removal, return, or replacement of its equipment; and no such representations are binding on Weber®.

This Warranty applies only to products sold at retail.

WEBER-STEPHEN PRODUCTS CO.

**Customer Service Center
1890 Roselle Road, Suite 308
Schaumburg, IL 60195
USA**

www.weber.com

General Instructions

Your Weber® gas barbecue is a portable outdoor cooking appliance. With the Weber® gas barbecue you can grill, barbecue, roast and bake with results that are difficult to duplicate with indoor kitchen appliances. The closed lid and Flavorizer® bars produce that “outdoor” flavor in the food.

The Weber® gas barbecue is portable so you can easily change its location in your yard or on your patio. Portability means you can take your Weber® gas barbecue with you if you move.

The natural gas supply is easy to use and gives you more cooking control than charcoal fuel.

- These instructions will give you the minimum requirements for assembling your Weber® gas barbecue. Please read the instructions carefully before using your Weber® gas barbecue. Improper assembly can be dangerous.
- Not for use by children.
- If there are local codes that apply to portable gas grills, you will have to conform to them. If there are no local codes, you must conform to the latest edition of the National Fuel Gas Code: ANSI Z 223.1/NFPA54.
- This Weber® gas barbecue is designed for natural (piped in city) gas only. Do not use liquid propane (LP) bottled gas. The valves, orifices and hose are for natural gas only.
- Do not use with charcoal fuel.
- Check that the area under the control panel and the bottom tray are free from debris that might obstruct the flow of combustion or ventilation air.

For Installation in Canada

These instructions, while generally acceptable, do not necessarily comply with the Canadian Installation codes, particularly with piping above and below ground. In Canada the installation of this appliance must comply with local codes and/or Standards CAN/CGA-B149.1 Natural Gas and Propane Installation Code.

Storage

- The gas must be turned OFF at the natural gas supply when the Weber® gas barbecue is not in use.
- When the Weber® gas barbecue is stored indoors, the gas supply must be disconnected.
- The Weber® gas barbecue should be checked for gas leaks and any obstructions in the burner tubes before using. (See Sections: “General Maintenance and Annual Maintenance.”)
- Check that the areas under the control panel and the slide out bottom tray are free from debris that might obstruct the flow of combustion or ventilation air.
- The Spider /Insect Screens should also be checked for any obstructions. (See Section: “Annual Maintenance.”)

Operating

- ▲ **WARNING: Only use this barbecue outdoors in a well-ventilated area. Do not use in a garage, building, breezeway or any other enclosed area.**
- ▲ **WARNING: Your Weber® gas barbecue shall not be used under an unprotected combustible roof or overhang.**
- ▲ **WARNING: Your Weber® gas barbecue is not intended to be installed in or on recreational vehicles and/or boats.**
- ▲ **WARNING: Do not use the barbecue within 24 inches of combustible materials, top, bottom, back or sides of the grill.**
- ▲ **WARNING: The entire cooking box gets hot when in use. Do not leave unattended.**
- ▲ **WARNING: Keep any electrical supply cord and the fuel supply hose away from any heated surface.**
- ▲ **WARNING: Keep the cooking area clear of flammable vapors and liquids, such as gasoline, alcohol, etc., and combustible materials.**

Gas Supply Testing

- Disconnect your Weber® gas barbecue when the gas supply is being tested at high pressures. This appliance and its individual shutoff valve must be disconnected from the gas supply piping system during any pressure testing of that system at test pressures in excess of 1/2 psig (3.5 kPa).
- Turn OFF your Weber® gas barbecue when the gas supply is being tested at low pressures. This appliance must be isolated from the gas supply piping system by closing its individual manual shutoff valve during any pressure testing of the gas supply piping system at the pressure equal to or less than 1/2 psig (3.5 kPa).

General Instructions

Grilling Methods

NOTE: If grill loses heat while cooking refer to the troubleshooting section of this manual.

⚠ WARNING: Do not move the Weber® gas barbecue when operating or while barbecue is hot.

You can adjust the Left and Right burners in each burner set as desired. The control settings are High (H), Medium (M), Low (L), or Off (O).

Note: The temperature inside your cooking box for the first few uses, while surfaces are still very reflective, may be hotter than those shown in your cookbook. Cooking conditions. Such as wind and weather, may require the adjustment of the burner controls to obtain the correct cooking temperatures.

If burners go out during cooking, open lid, turn off all burners and wait five minutes before relighting.

Preheating - Your Weber® gas barbecue is an energy-efficient appliance. It operates at an economical low BTU rate. To preheat: after lighting, close lid and turn all burners to high (HH). Preheating to between 500° and 550° F (260° and 290° C) will take 10 to 15 minutes depending on conditions such as air temperature and wind.

Drippings and grease - The Flavorizer® bars are designed to “smoke” the correct amount of drippings for flavorful cooking. Excess drippings and grease will accumulate in the catch pan under the slide out bottom tray. Disposable foil drip pans are available that fit the catch pan.

⚠ WARNING: Check the bottom tray for grease build-up before each use. Remove excess grease to avoid a grease fire in the slide out bottom tray.

Cleaning

⚠ WARNING: Turn your Weber® gas barbecue OFF and wait for it to cool before cleaning.

⚠ CAUTION: Do not clean your Flavorizer® bars or cooking grates in a self-cleaning oven.

For availability of replacement cooking grates and Flavorizer® bars contact the Customer Service Representative in your region using the contact information sheet provided with your manual.

Outside surfaces - Use a warm soapy water solution to clean, then rinse with water.

⚠ CAUTION: Do not use oven cleaner, abrasive cleansers (kitchen cleansers) cleaners that contain citrus products, or abrasive cleaning pads on barbecue or cart surfaces.

Slide out Bottom tray - Remove excess grease, then wash with warm soapy water, then rinse

Flavorizer® bars and Cooking grates - Clean with a suitable brass bristle brush. As needed, remove from grill and wash with warm soapy water, then rinse with water.

Catch pan - Disposable foil trays are available, or you can line the catch pan with aluminum foil. To clean the catch pan, wash with warm soapy water, then rinse.

Thermometer - Wipe with warm soapy water; clean with plastic scrub ball.

Inside cooking module - Brush any debris off of burner tubes. **DO NOT ENLARGE BURNER PORTS (OPENINGS).** Wash inside of cooking box with warm soapy water and a water rinse.

Inside Lid - While lid is warm, wipe inside with paper towel to prevent grease build-up. Flaking built-up grease resembles paint flakes.

Stainless steel surfaces - Wash with a soft cloth and a soap and water solution. Be careful to scrub with the grain direction of the stainless steel.

Thermoset surfaces - Wash with a soft cloth and a soap and water solution.

Do not use cleaners that contain acid, mineral spirits or xylene. Rinse well after cleaning.

Thermoset work surfaces are not to be used as cutting boards.

Summit® Silver A Exploded View

Summit® Silver A NG 032403

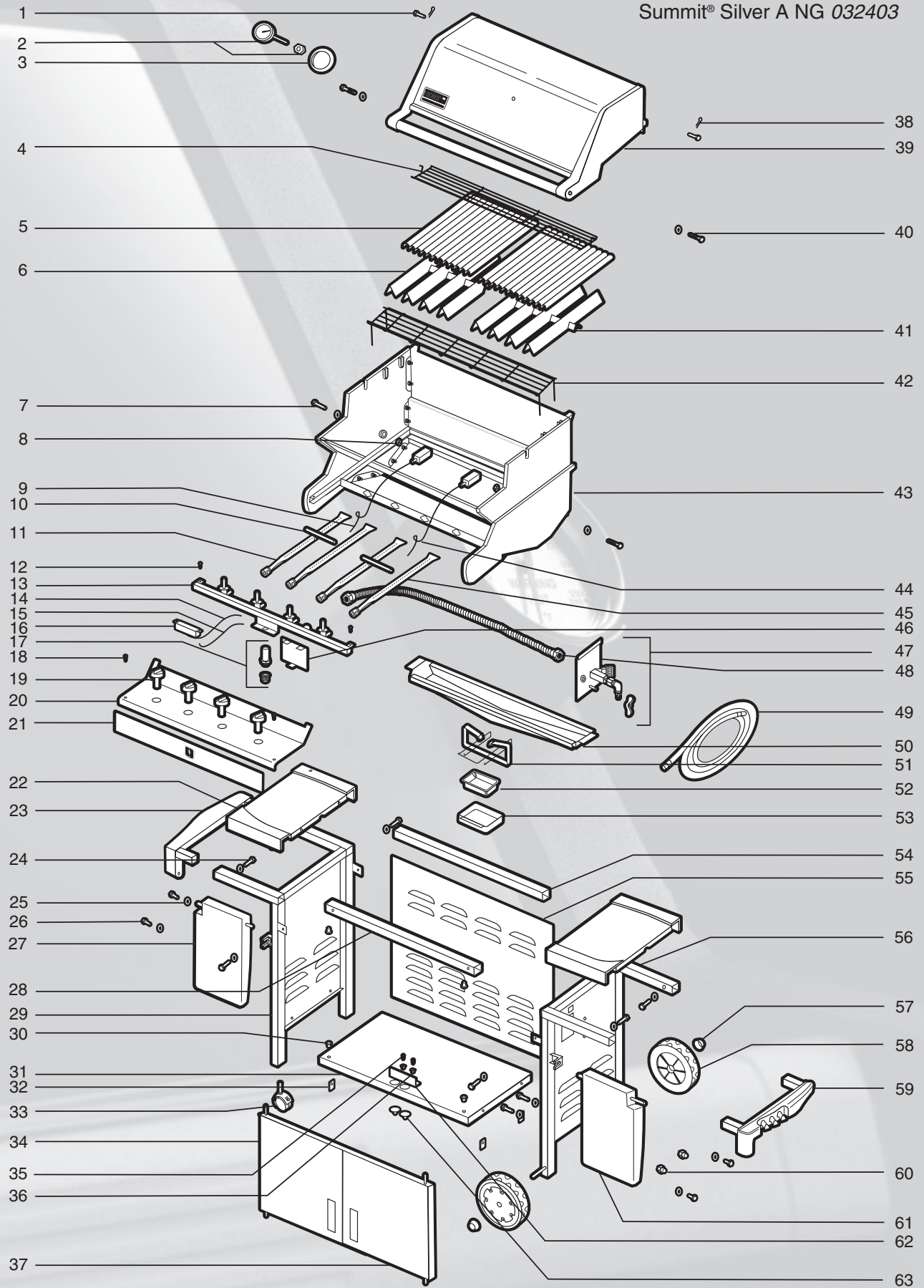

Summit® Silver A Exploded View List

1. Hinge Pin
2. Thermometer Hardware
3. Thermometer Bezel
4. Warm-Up™ Basket
5. 12 inch Cooking Grate
6. Left Flavorizer® Bar Assembly
7. Cookbox Assembly Hardware
8. 1/4 - 20 inch Hex Nut
9. Electrode Assembly
10. Crossover® Tube
11. Left Burner Tube
12. 1/4 - 20 x 1/2 inch Phillips Screw
13. Manifold
14. Negative Ignition Switch Wire
15. Positive Ignition Switch Wire
16. Two Output Ignition Module Assembly
17. Ignition Switch Button Assembly
18. 10 - 24 x 1/2 inch Black Screw
19. Control Knob
20. Control Panel
21. Front Panel
22. Left Work Surface
23. Left Trim Piece
24. 1/4 - 20 x 1 inch Black Bolt
25. Nylon Washer
26. 1/4 - 20 x 1/2 inch Black Bolt
27. Left Swing-Up Table
28. Front Frame Rail
29. Caster Frame Assembly
30. Door Bushing
31. Bottom Shelf
32. Mounting Clip
33. Caster Assembly
34. Left Door Assembly
35. 10 -16 x 3/4 Screw w/ Washer
36. Plastic Plug
37. Right Door
38. Hair Pin Cotter
39. Lid Assembly
40. 1/4 - 20 x 1 1/4 inch Bolt
41. Right Flavorizer® Bar Assembly
42. Warming Rack
43. Cooking Box Assembly
44. Electrode Assembly
45. Right Burner Tube
46. Battery Shield Assembly
47. Manifold Assembly
48. Main Gas Line
49. Hose
50. Bottom Tray
51. Summit Catch Pan Holder
52. Summit Catch Pan
53. Summit Drip Pan
54. Rear Frame Rail
55. Rear Panel
56. Wheel Frame Assembly
57. Hubcap
58. Wheel
59. Right Trim Piece
60. Cylinder Glides
61. Right Swing-Up Table
62. Door Stop
63. Door Plug

Summit® Gold A Exploded View

Summit® Gold A NG 032403

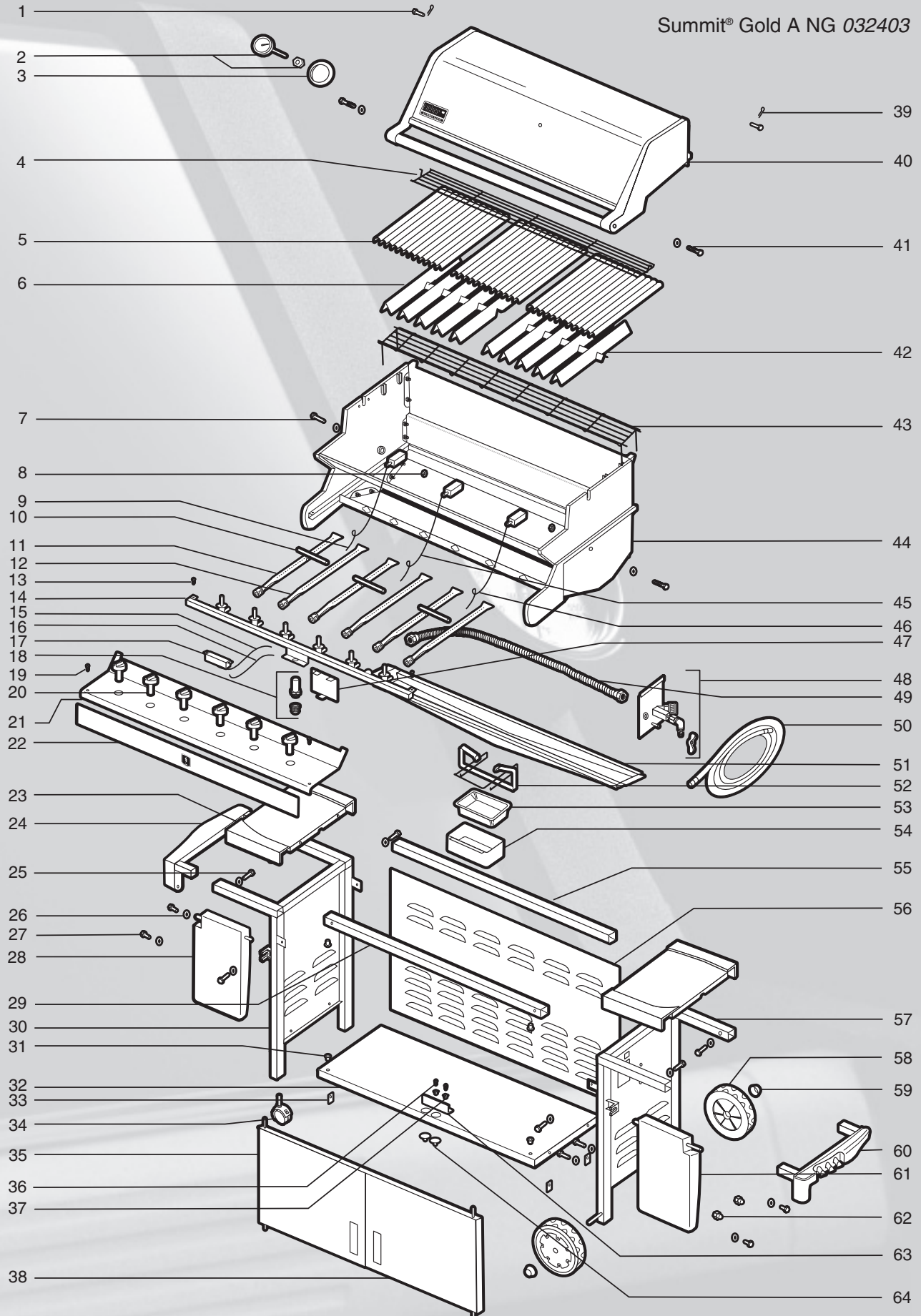

Summit® Gold A Exploded View List

1. Hinge Pin
2. Thermometer Hardware
3. Thermometer Bezel
4. Warm-Up™ Basket
5. 12 inch Cooking Grate
6. Left Flavorizer® Bar Assembly
7. Cookbox Assembly Hardware
8. 1/4 - 20 inch Hex Nut
9. Electrode Assembly
10. Crossover® Tube
11. Left Burner Tube
12. Right Burner Tube
13. 1/4 - 20 x 1/2 inch Phillips Screw
14. Manifold
15. Negative Ignition Switch Wire
16. Positive Ignition Switch Wire
17. Three Output Ignition Module Assembly
18. Ignition Switch Button Assembly
19. 10 - 24 x 1/2 inch Black Screw
20. Control Knob
21. Control Panel
22. Front Panel
23. Left Work Surface
24. Left Trim Piece
25. 1/4 - 20 x 1 inch Black Bolt
26. Nylon Washer
27. 1/4 x 20 x 1/2 inch Black Bolt
28. Left Swing-Up Table
29. Front Frame Rail
30. Caster Frame Assembly
31. Door Bushing
32. Bottom Shelf
33. Mounting Clip
34. Caster Assembly
35. Left Door Assembly
36. 10 - 16 x 3/4 w/ Washer
37. Plastic Plug
38. Right Door
39. Hair Pin Cotter
40. Lid Assembly
41. 1/4 - 20 x 1 1/4 inch Bolt
42. Right Flavorizer Bar Assembly
43. Warming Rack
44. Cookbox Assembly
45. Electrode Assembly
46. Electrode Assembly
47. Battery Shield Assembly
48. Manifold Assembly
49. Main Gas Line
50. Hose
51. Bottom Tray
52. Summit Catch Pan Holder
53. Summit Catch Pan
54. Summit Drip Pan
55. Rear Frame Rail
56. Rear Panel
57. Wheel Frame Assembly
58. Wheel
59. Hubcap
60. Right Trim Piece
61. Right Swing-Up Table
62. Cylinder Glides
63. Door Stop
64. Door Plug

Summit® Silver A Parts List

Lid - 1

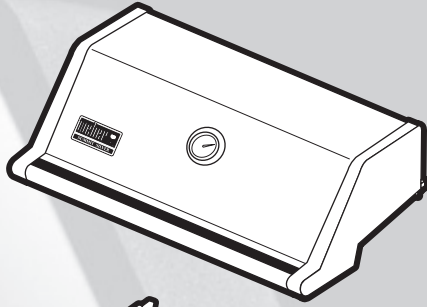

Cookbox - 1

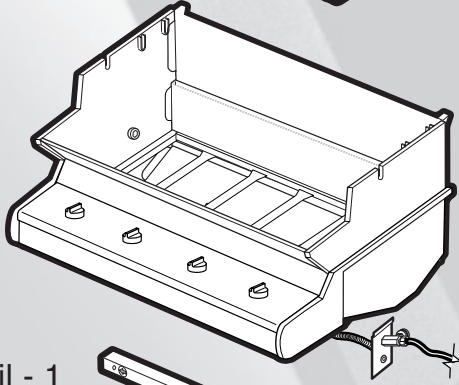

Front Frame Rail - 1



Rear Frame Rail - 1

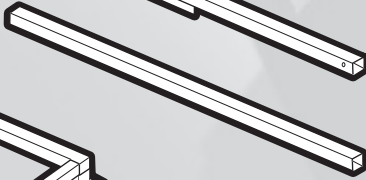

Left Frame Assembly - 1

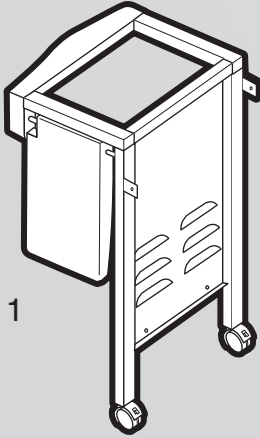

Right Frame Assembly - 1

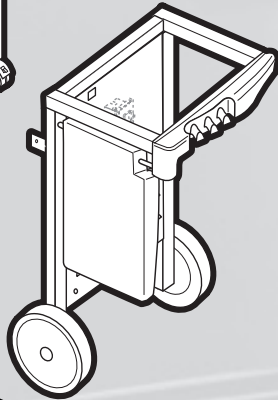

Rear Panel - 1

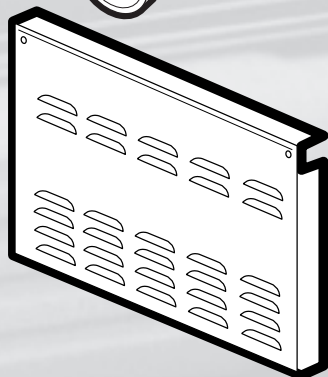

Bottom Shelf - 1

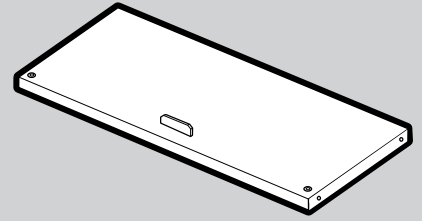

Left Door - 1

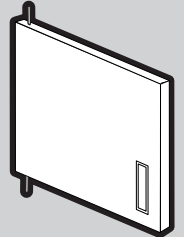

Right Door - 1

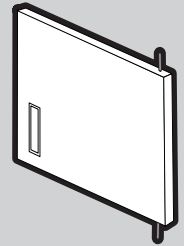

Side Table - 2

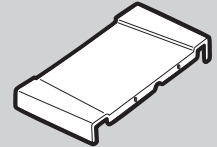

Warming Rack - 1

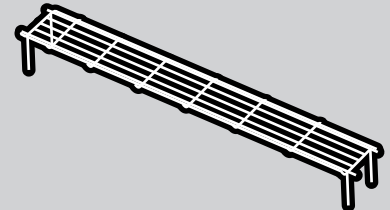

Warm-Up™ Rack - 1

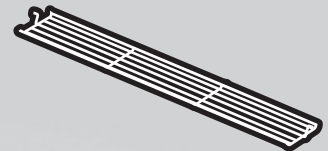

Summit® Silver A Parts List

Flavorizer® Bars - 2 Sets

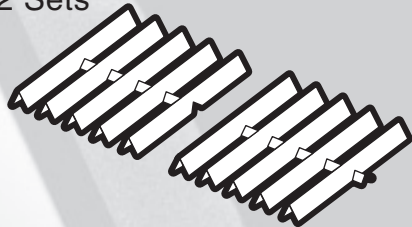

Stainless Steel Cooking Grates - 2

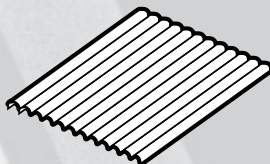

Bottom Tray - 1



Catch-Pan Holder - 1



Catch-Pan - 1



Disposable Drip Pans - 2

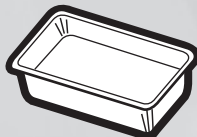

Hinge Pin- 2



Hair Pin Cotter- 2



1-1/4 inch Bolts
(1/4 x 20 x 1-1/4 inch Bolt) - 2

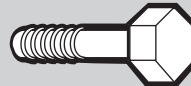

Nut Hex (1/4 x 20 Blk Zinc) - 2



1/2 inch Bolts
(1/4 x 20 x 1/2 inch Bolt) - 8

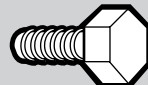

Nylon Washer - 10



Wing Nut (10-24) - 2



Plastic Washer - 1



Wrench - 1



7/16 inch Wrench - 1

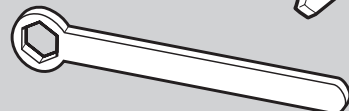

Hose - 1

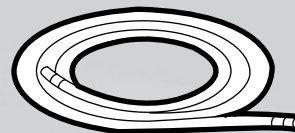

Summit® Gold A Parts List

Lid - 1

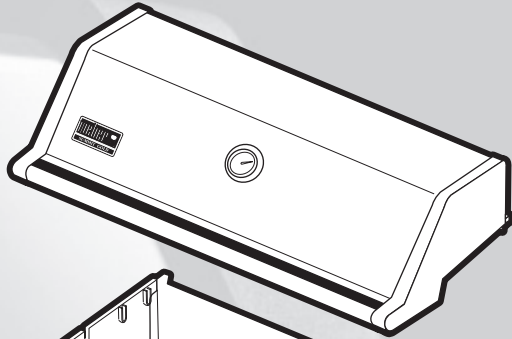

Cookbox - 1

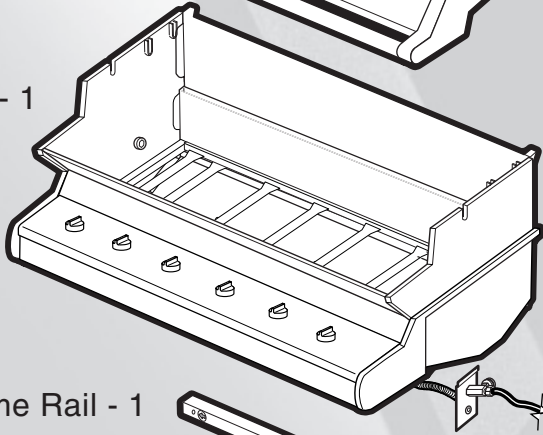

Front Frame Rail - 1



Rear Frame Rail - 1



Left Frame Assembly - 1

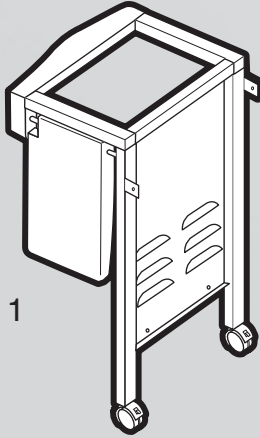

Right Frame Assembly - 1

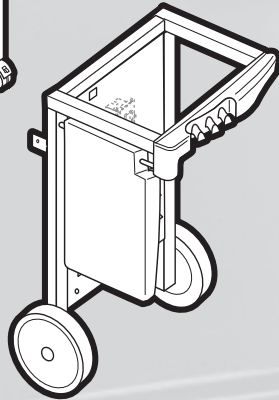

Rear Panel - 1

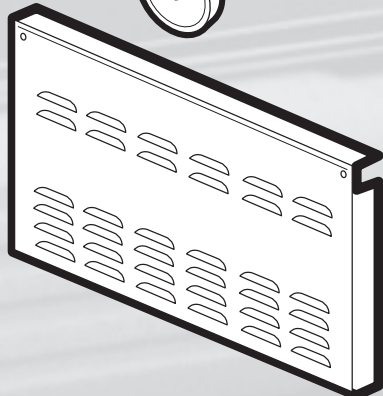

Bottom Shelf - 1

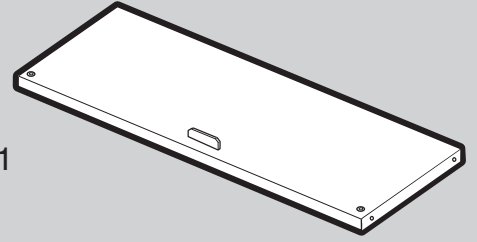

Left Door - 1

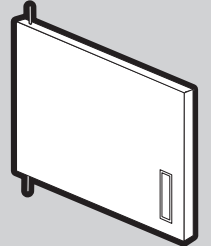

Right Door - 1

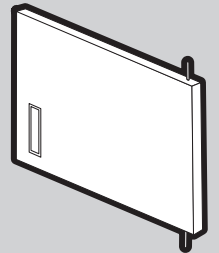

Side Table - 2

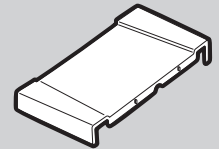

Warming Rack - 1

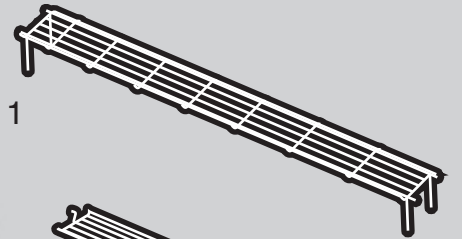

Warm-Up™ Rack - 1

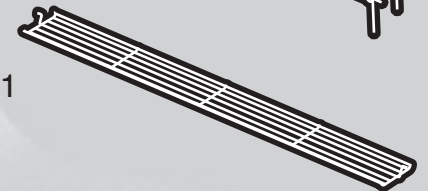

Summit® Gold A Parts List

Flavorizer® Bars - 2 Sets

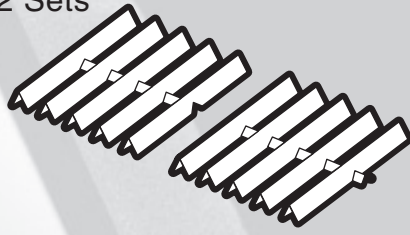

Stainless Steel
Cooking Grates - 3

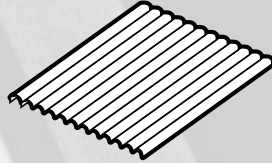

Bottom Tray - 1

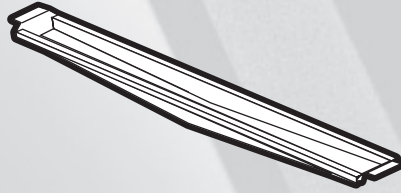

Catch-Pan Holder - 1

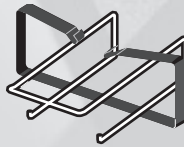

Catch-Pan - 1



Disposable Drip Pans - 2

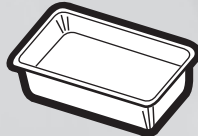

Hinge Pin- 2



Hair Pin Cotter- 2



1-1/4 inch Bolts
(1/4 x 20 x 1-1/4 inch Bolt) - 2

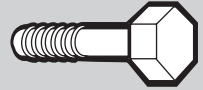

Nut Hex (1/4 x 20 Blk Zinc) - 2



1/2 inch Bolts
(1/4 x 20 x 1/2 inch Bolt) - 8

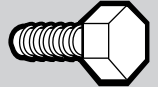

Nylon Washer - 10



Wing Nut (10-24) - 2



Plastic Washer - 1



Wrench - 1



7/16 inch Wrench - 1

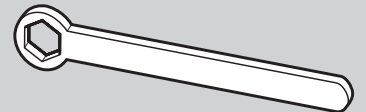

Hose - 1





1

Place corrugated from each side of the Cookbox under the Caster and Wheel Frame Assembly to level the frames for Frame Rail Assembly.

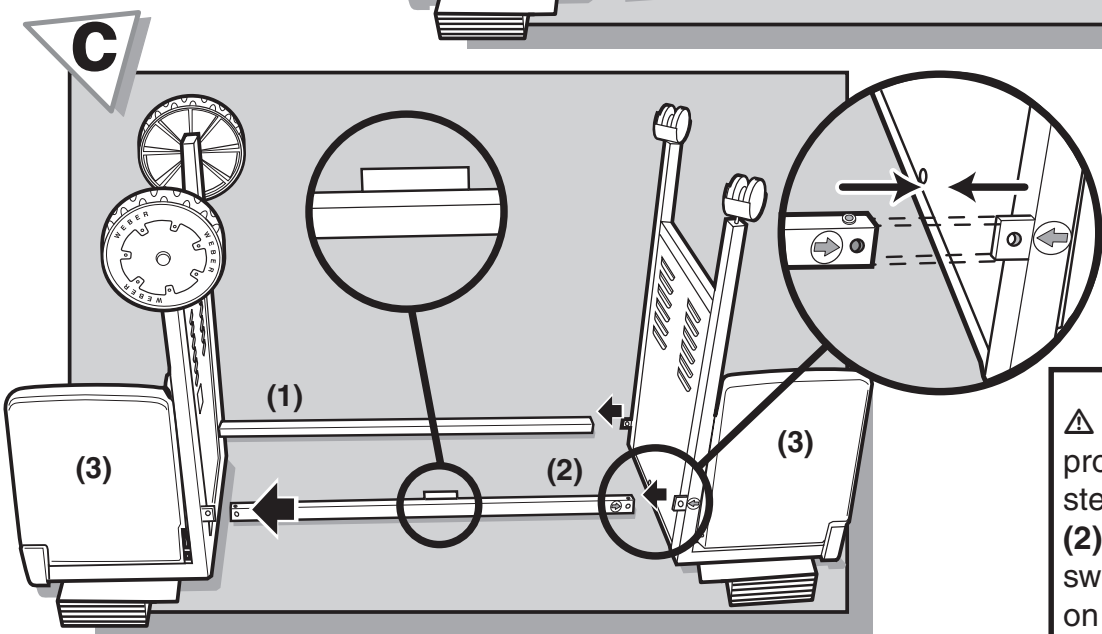
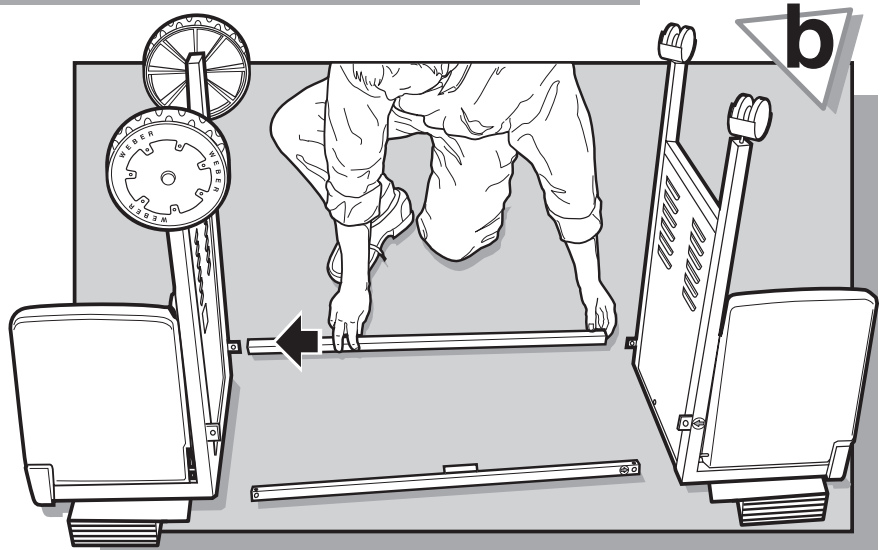
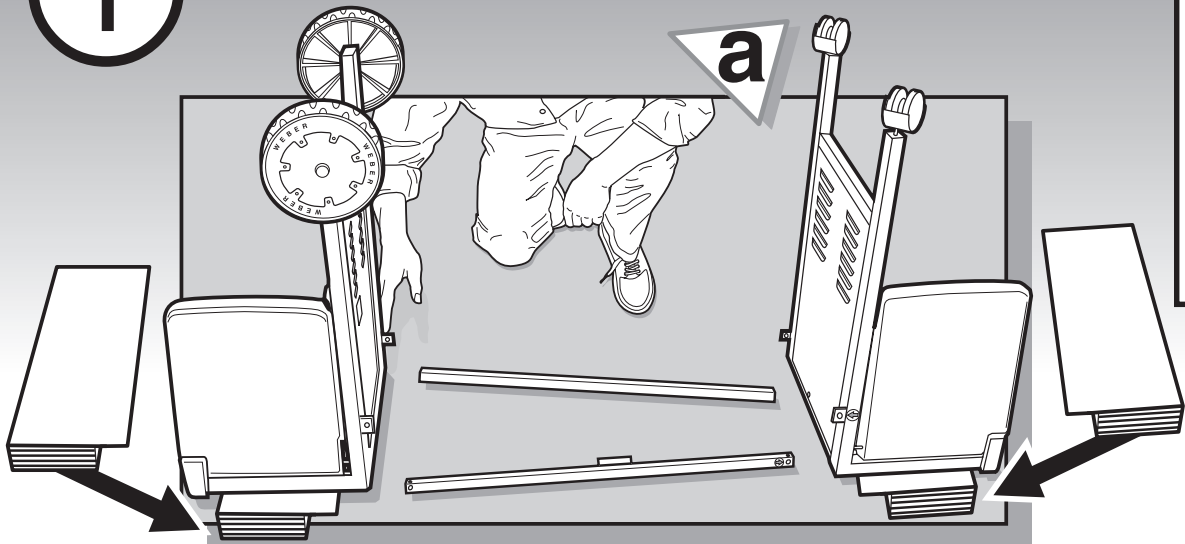

⚠ CAUTION: Before proceeding to the next step check that frame rail (2) is on the side with the swing tables (3). The tab on frame rail (2) must be facing toward the wheels.



2

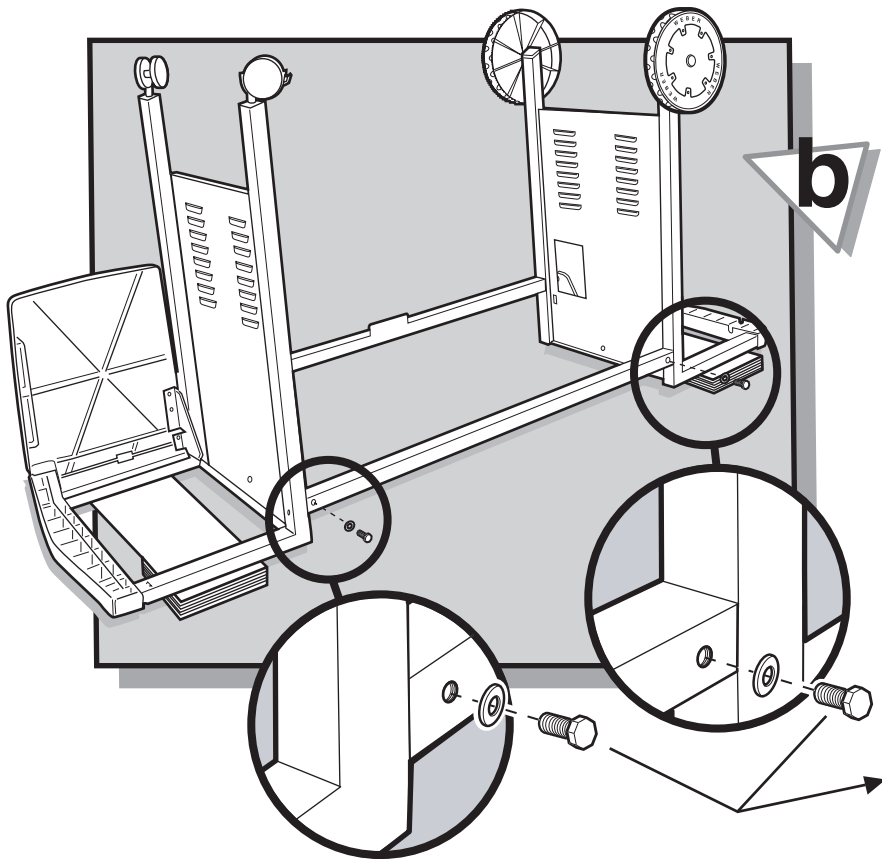
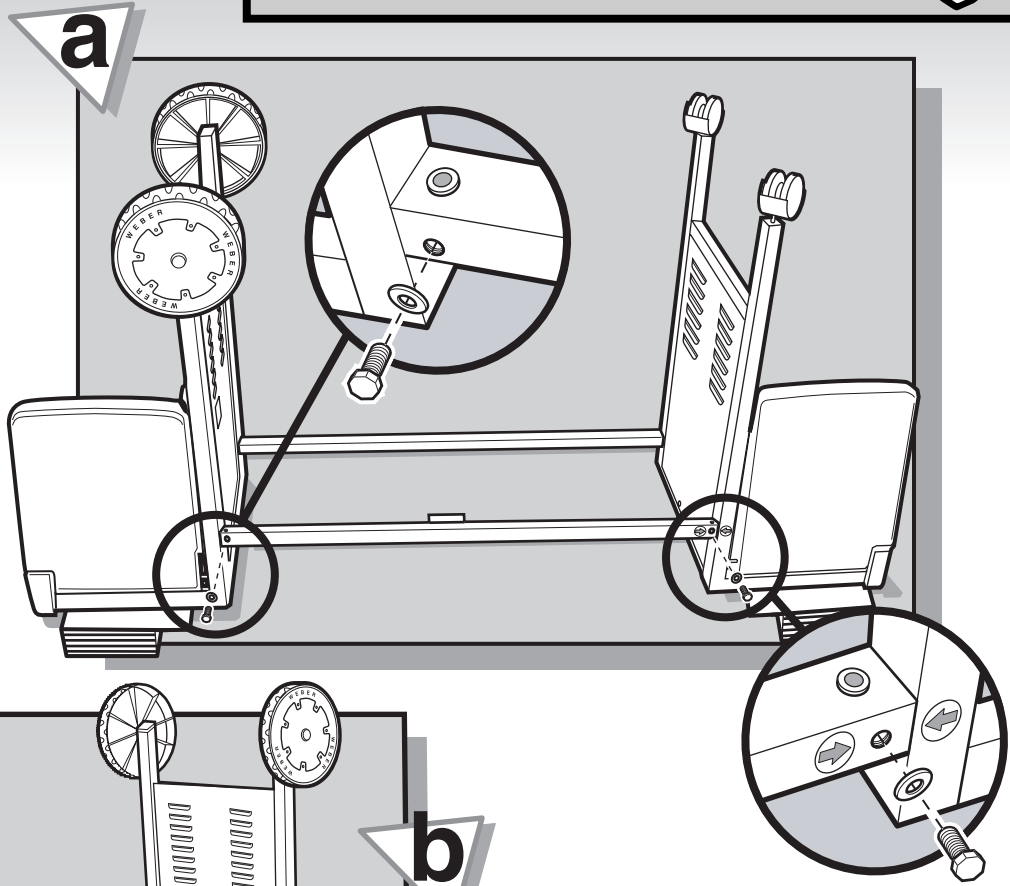
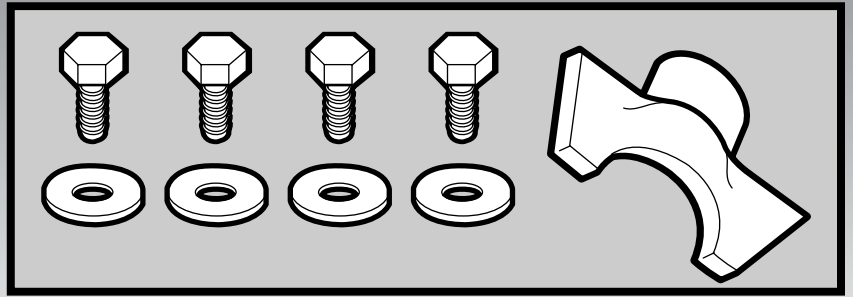

⚠ ATTENTION!
Only start these bolts.
Do not tighten yet.

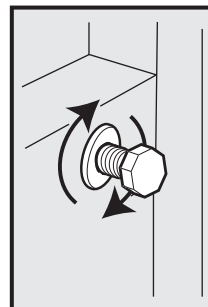



3

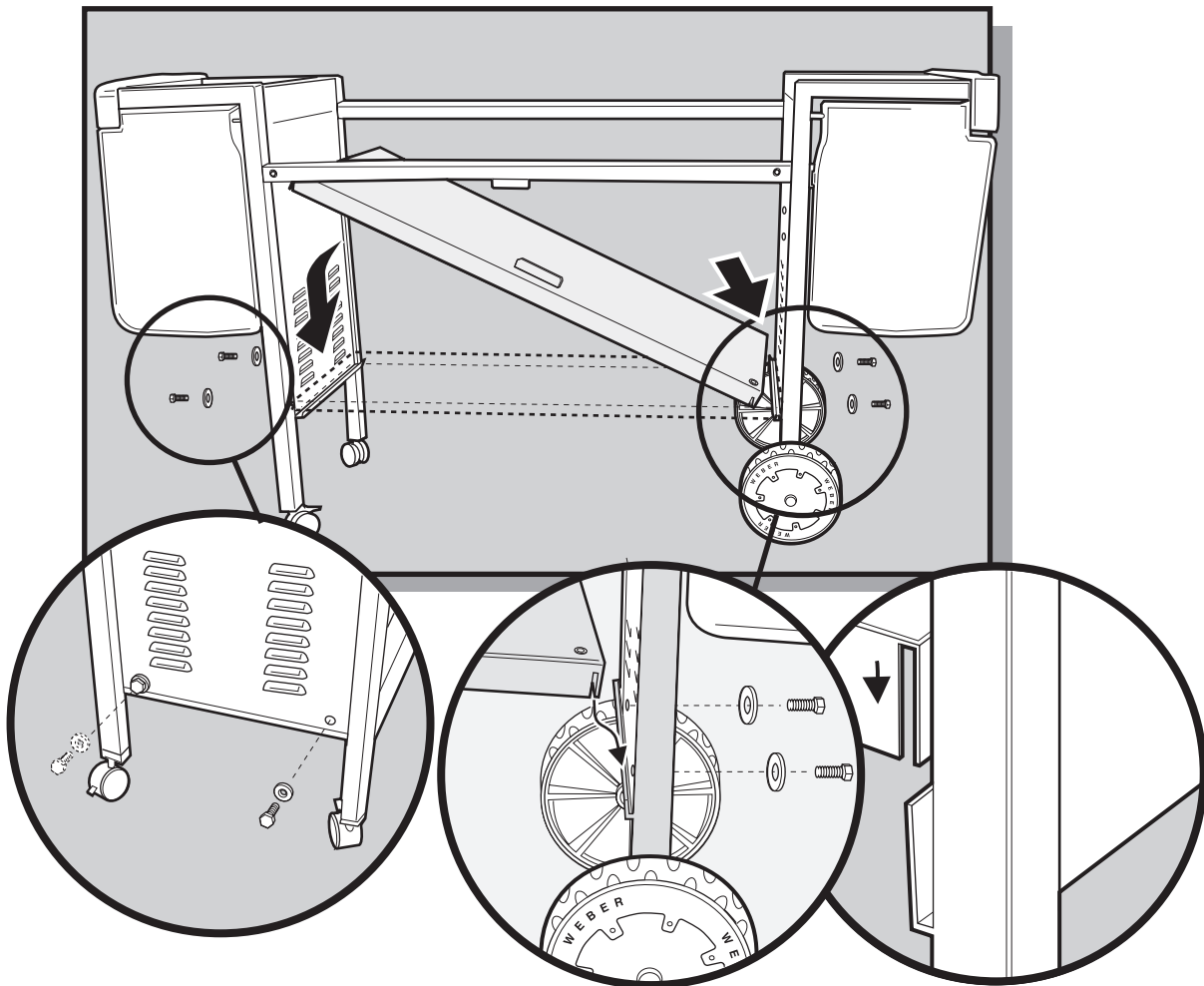
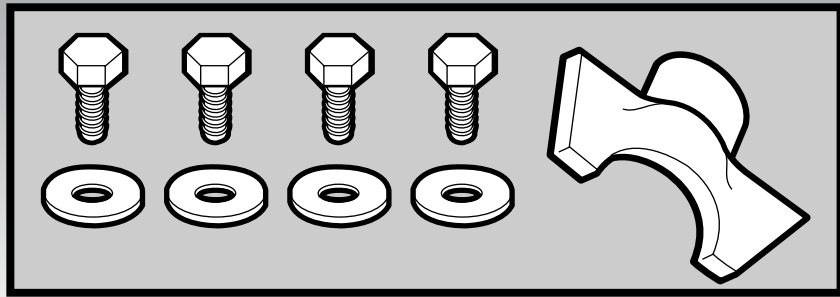



4

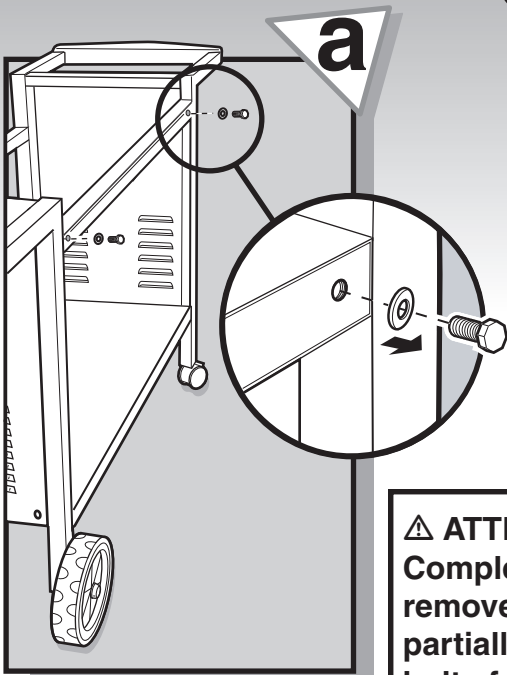
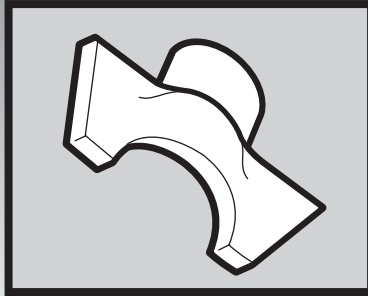

⚠ ATTENTION!
Completely
remove both
partially started
bolts from top
rear frame rail

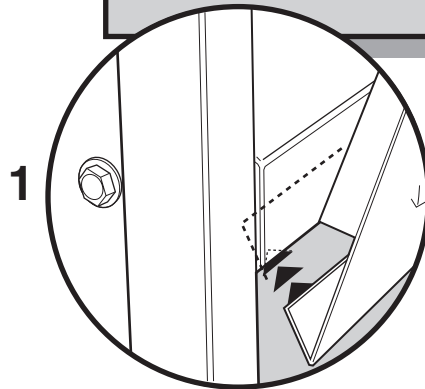
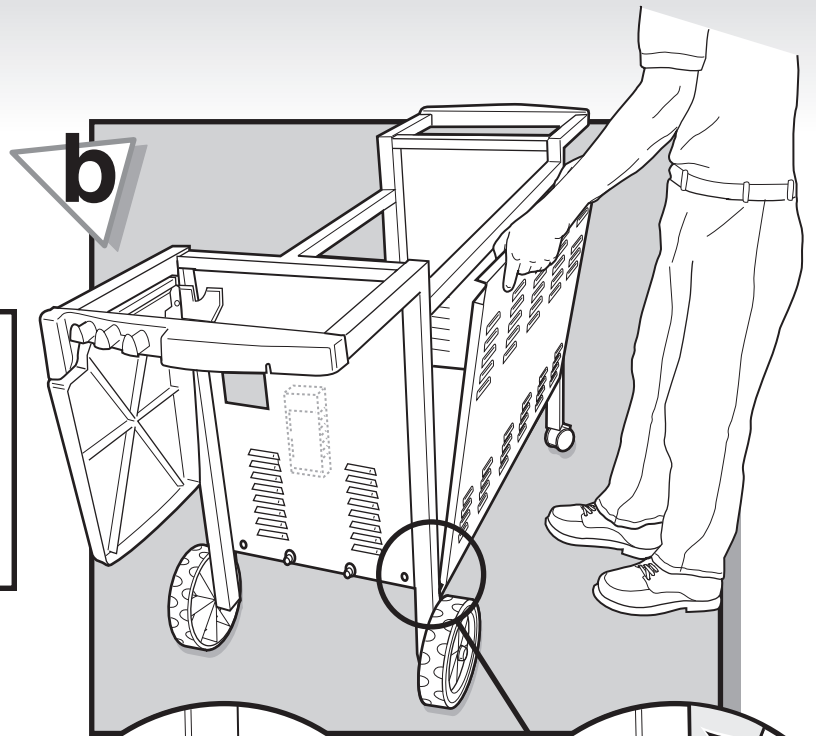

⚠ ATTENTION!
Reinstall both
bolts through
rear panel and
into rear frame rail.

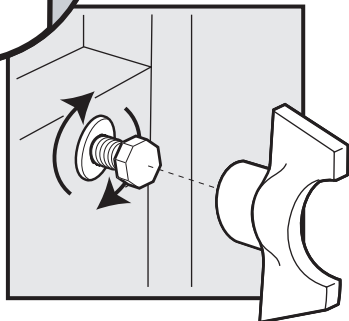



5

⚠ ATTENTION!
Remove packing tape holding the gas line and bracket(1).
When installing cookbox route the gas line and bracket(1) inside the frame rails(2).



SUMMIT® SILVER

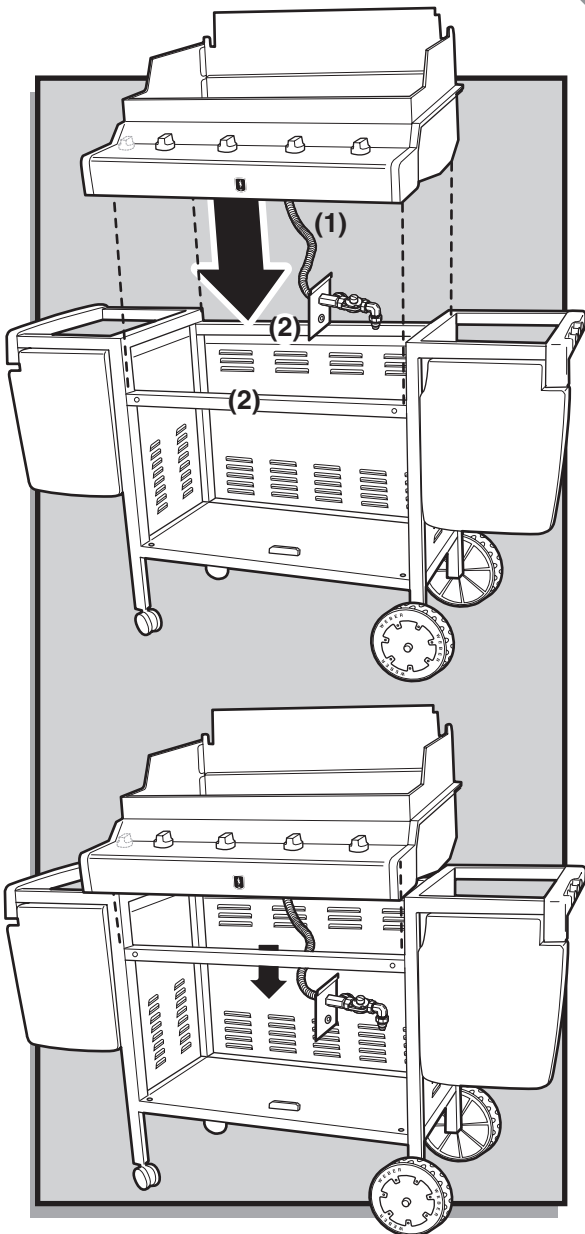

SUMMIT® GOLD

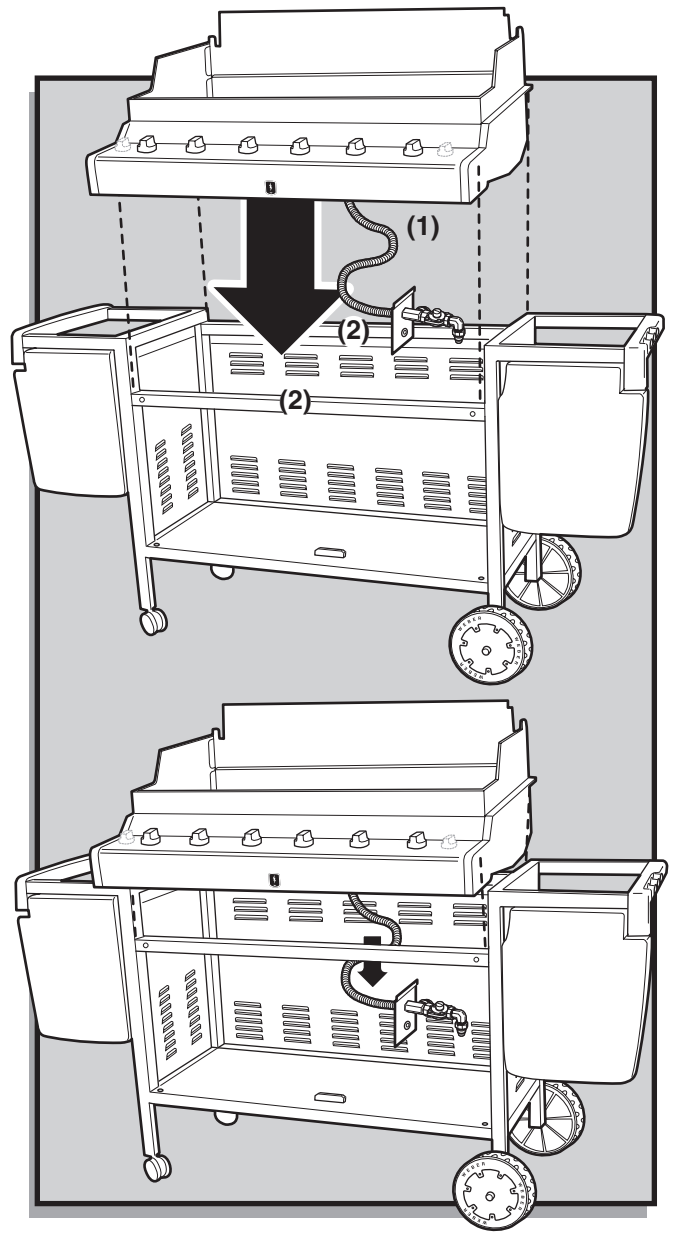



6

SUMMIT® SILVER

b

SUMMIT® GOLD

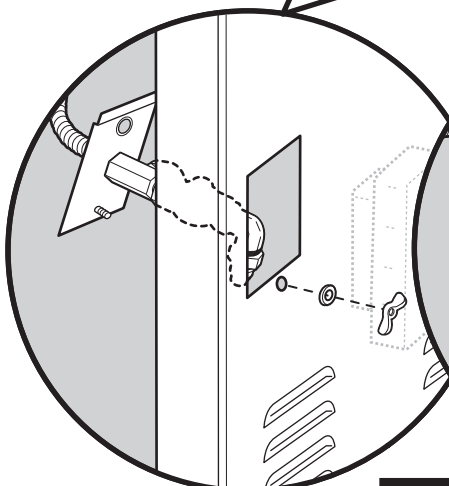
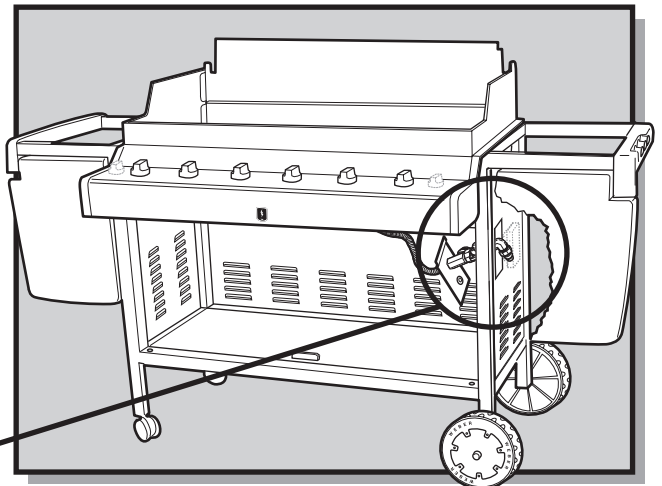
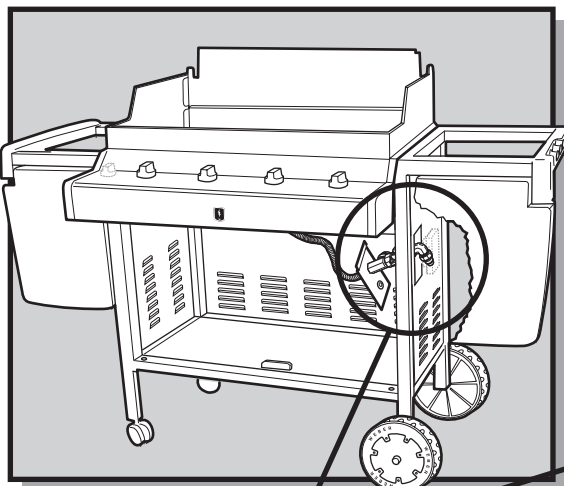
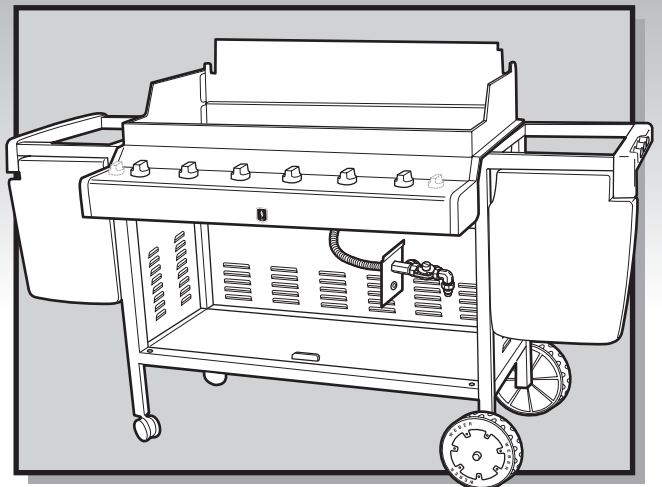
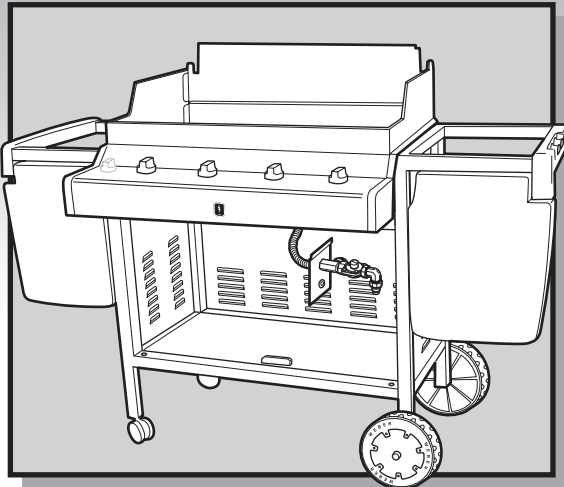

(1)

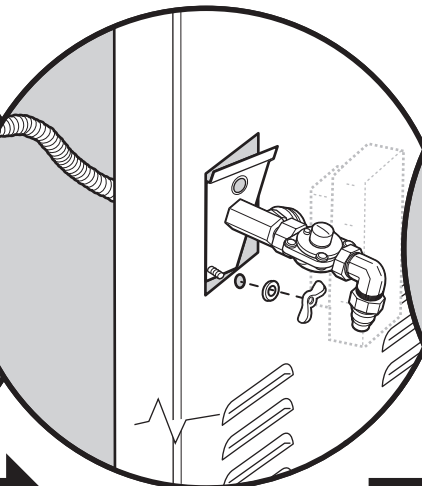

(2)

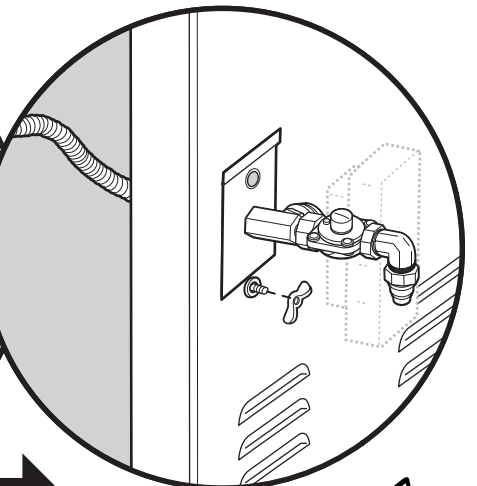

(3)





7

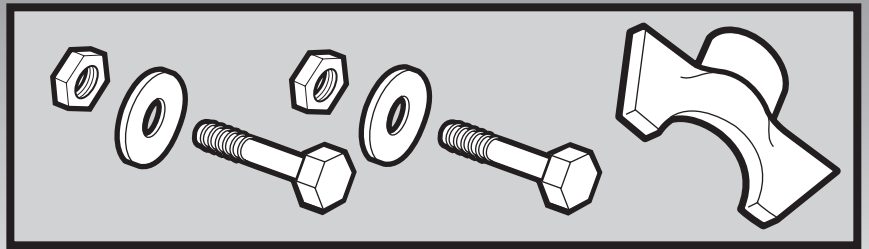

C

SUMMIT® SILVER

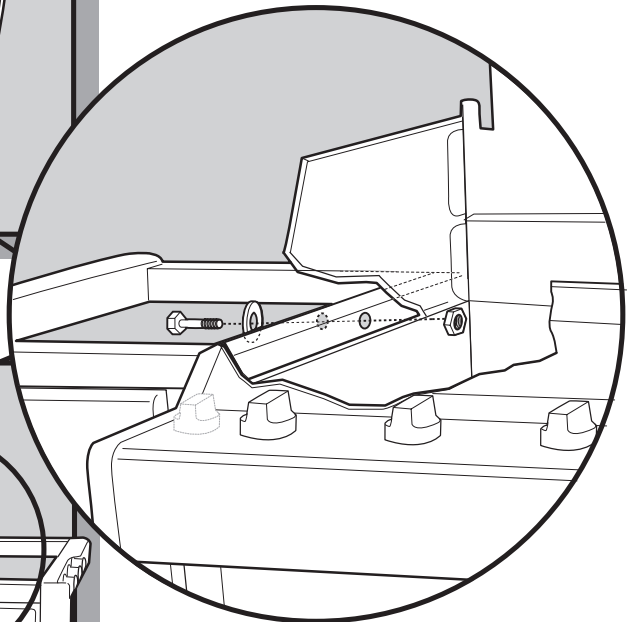
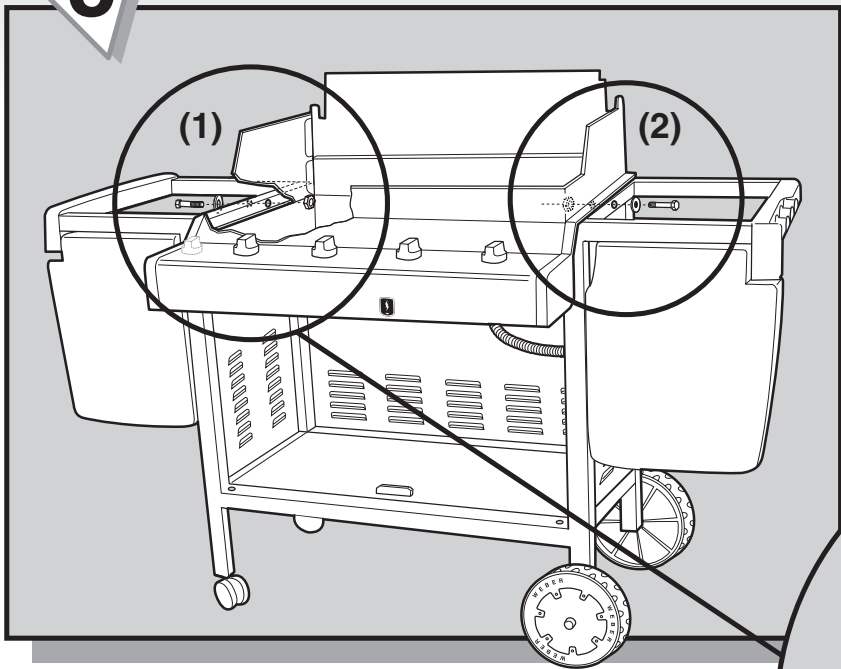

SUMMIT® GOLD

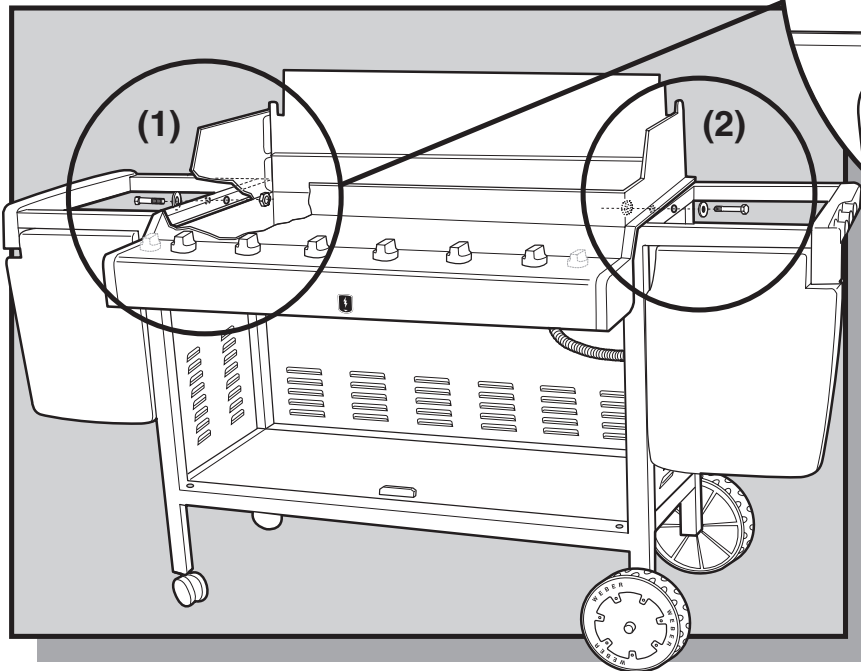



8

SUMMIT® SILVER

SUMMIT® GOLD

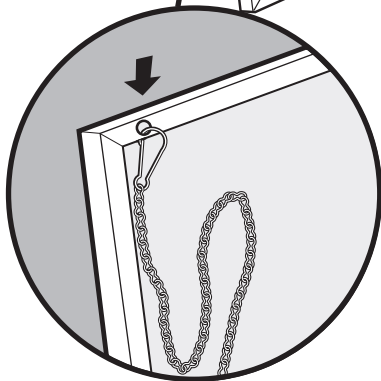
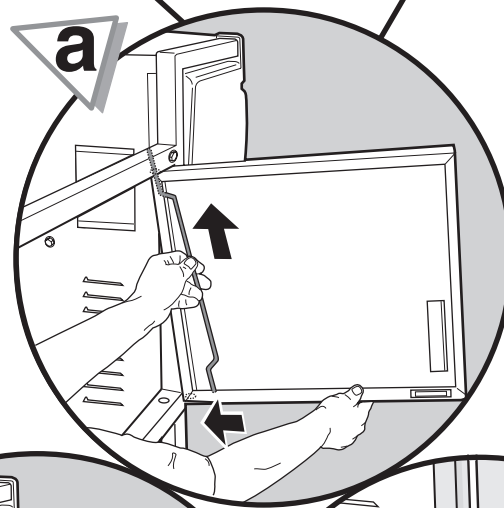
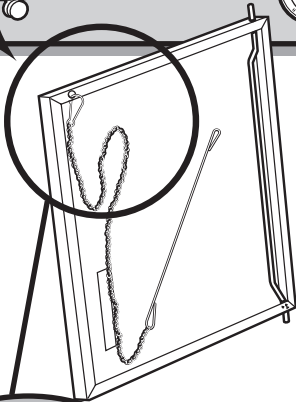
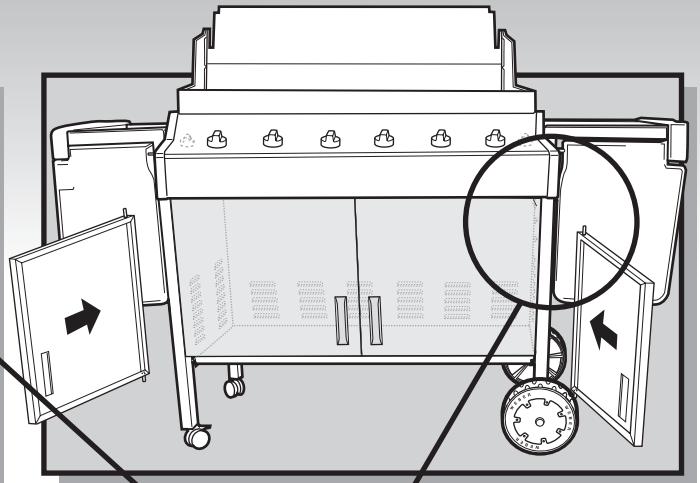
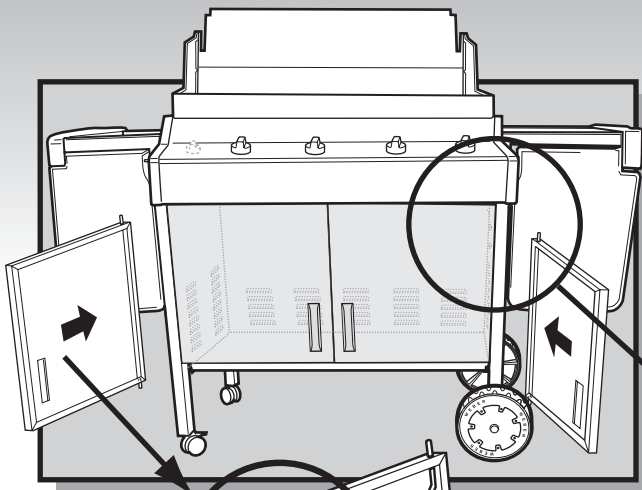

Matchlight Holder

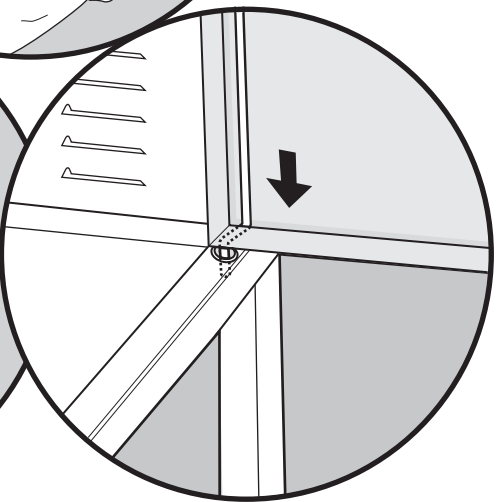
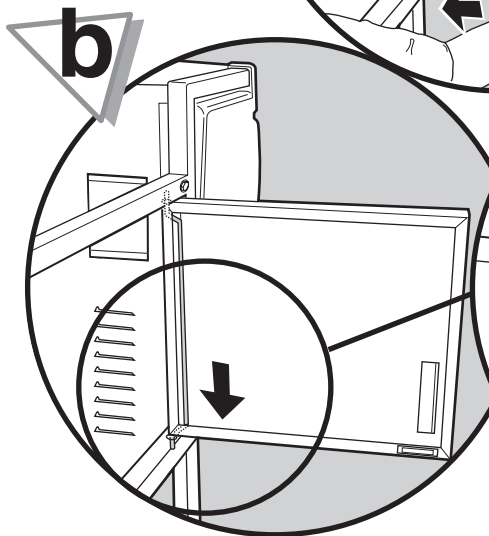



9

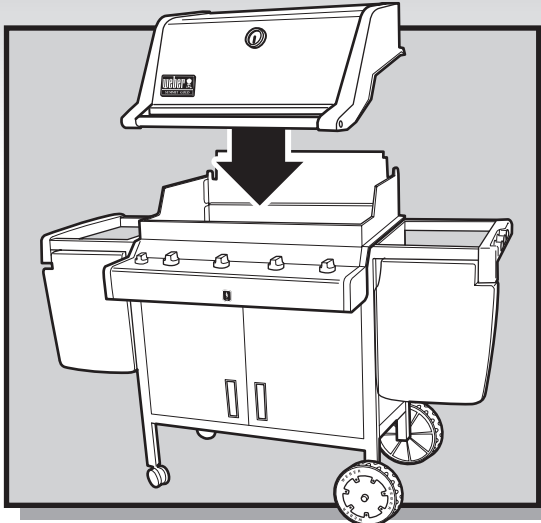
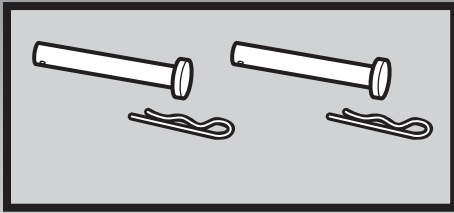

SUMMIT® SILVER

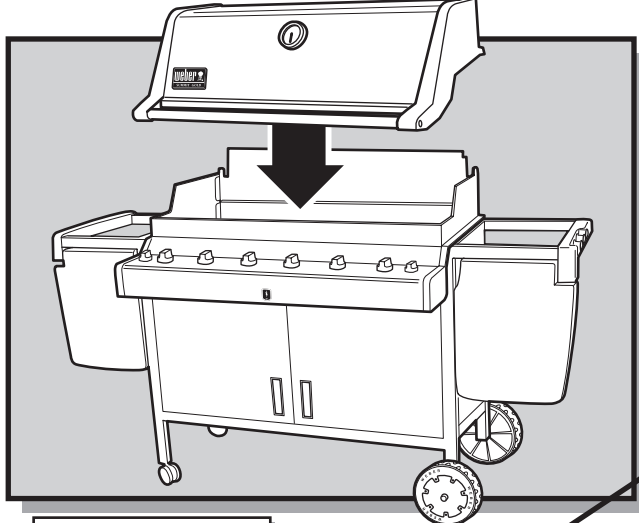

SUMMIT® GOLD

a

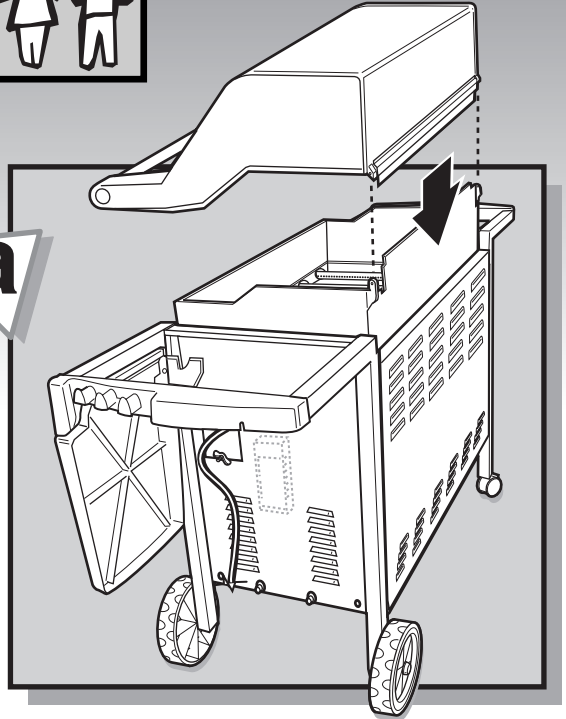

b

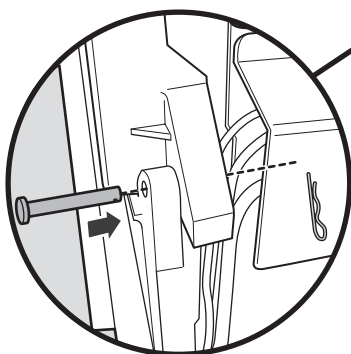
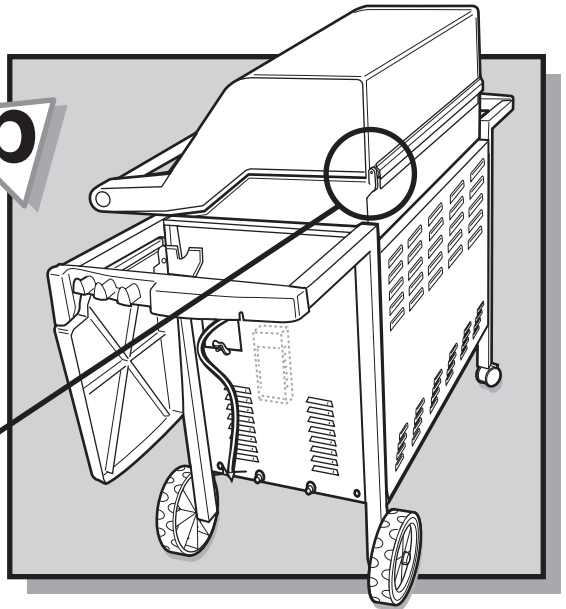

(1)

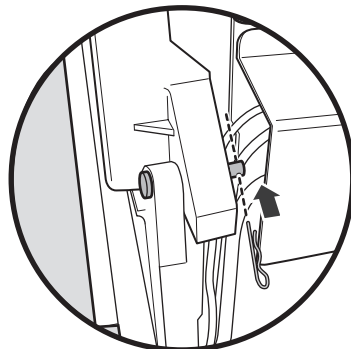

(2)

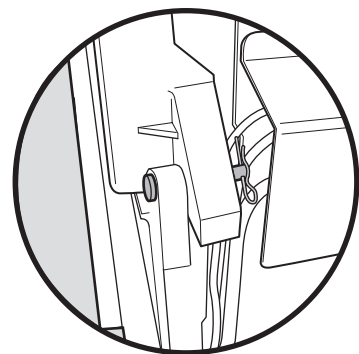

(3)



10

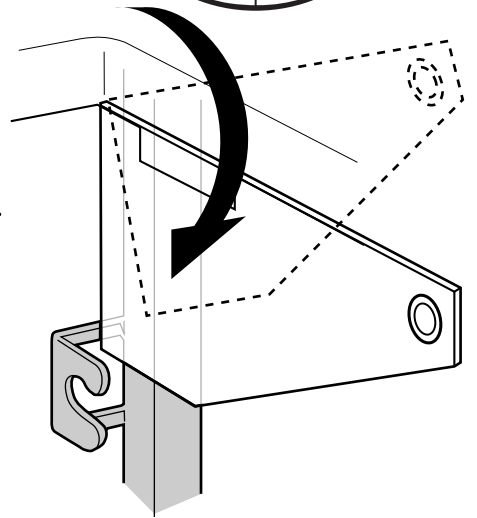
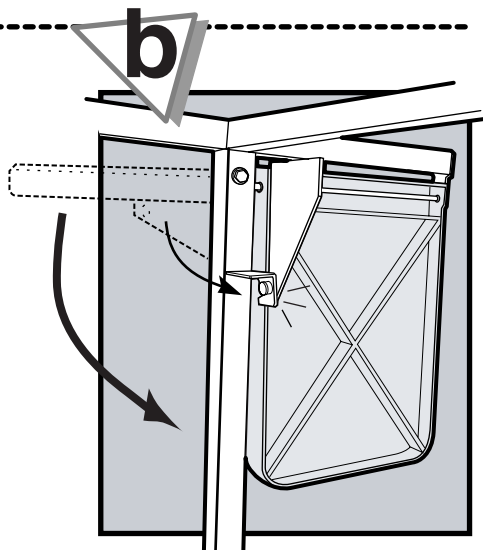
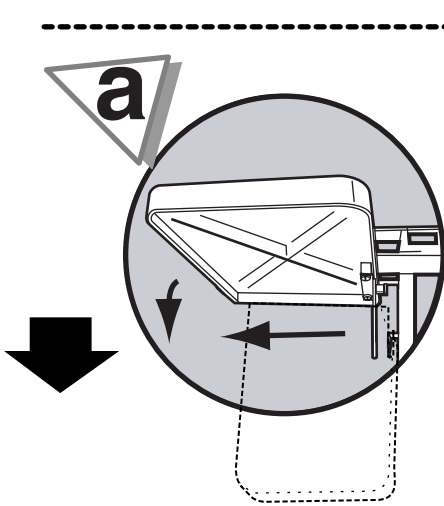
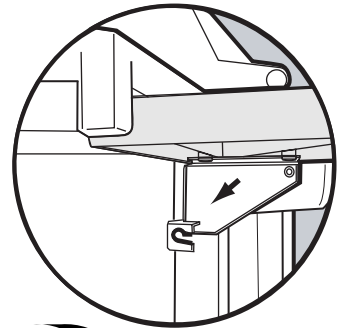
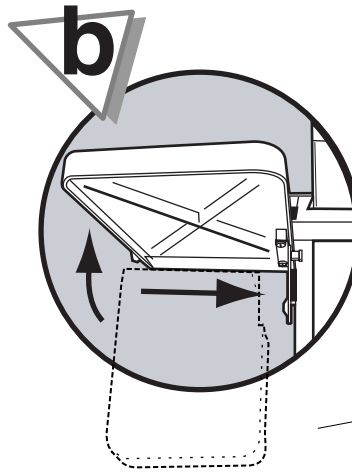
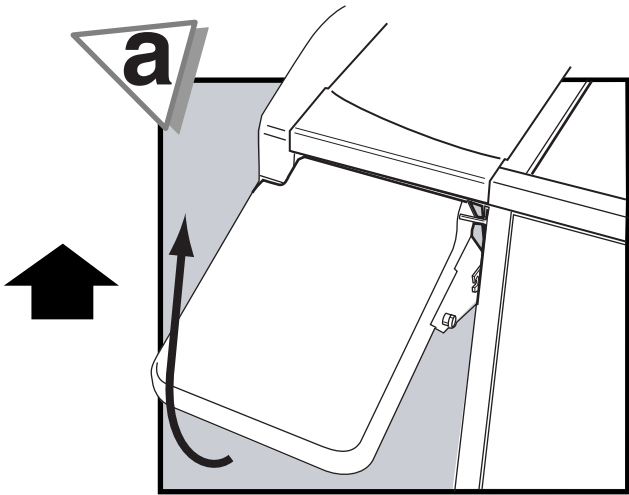
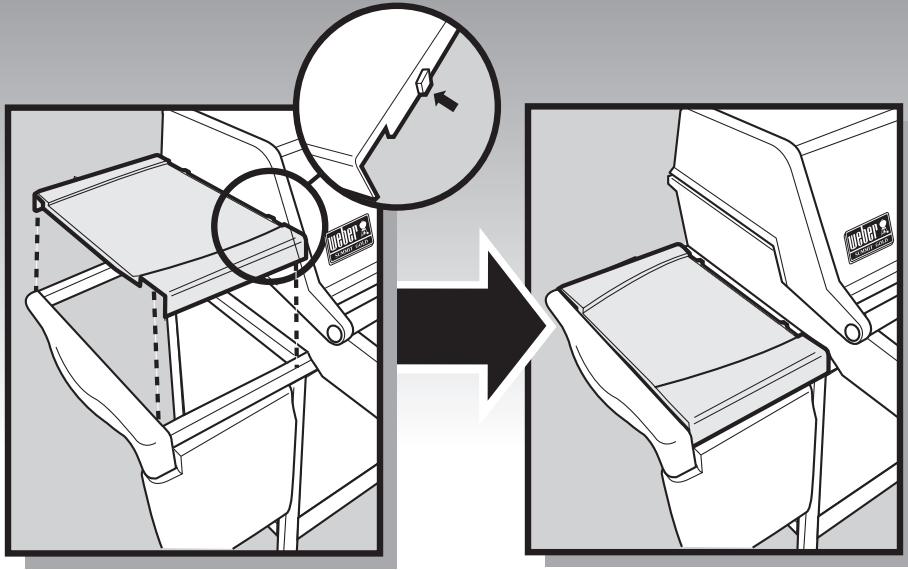



11

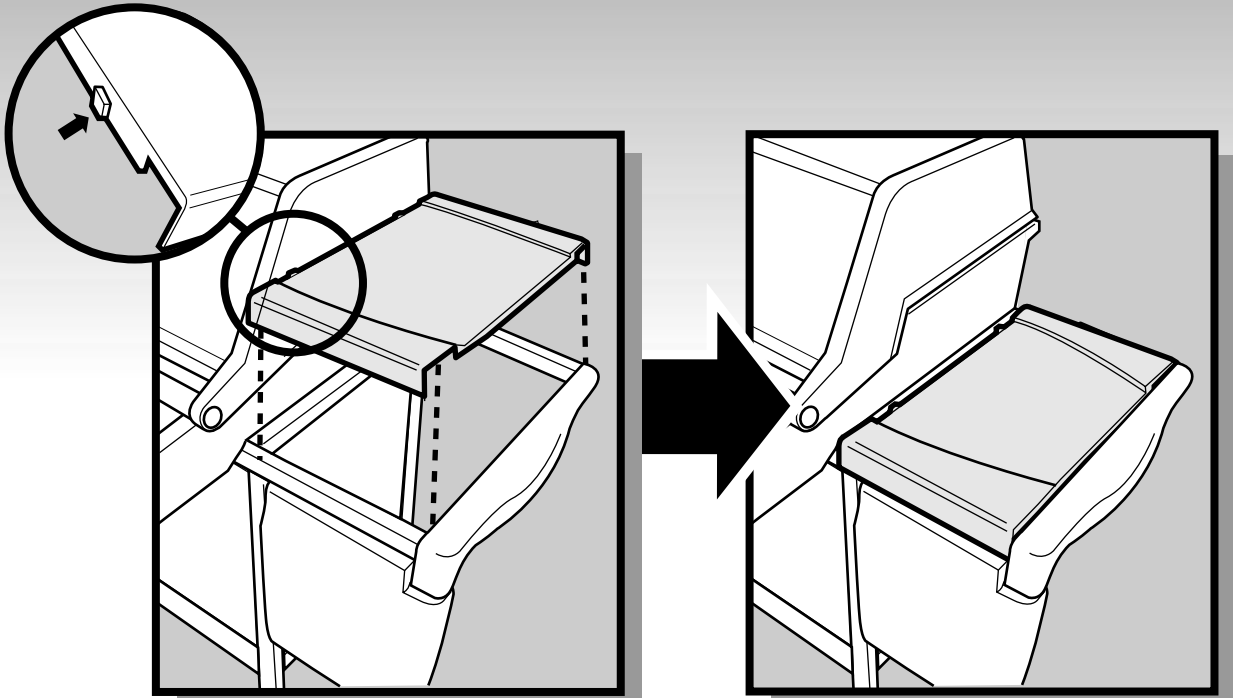

12

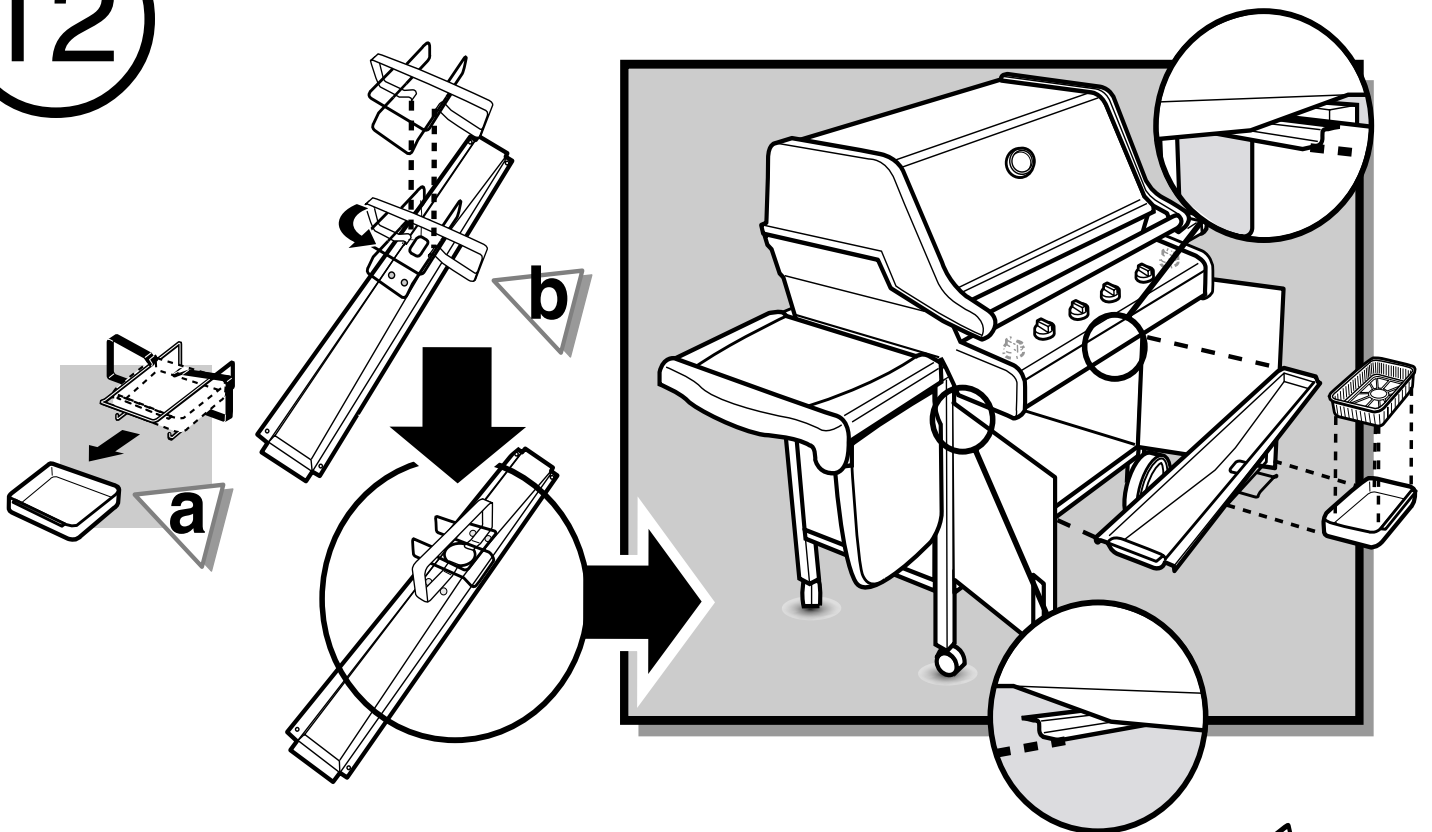



13

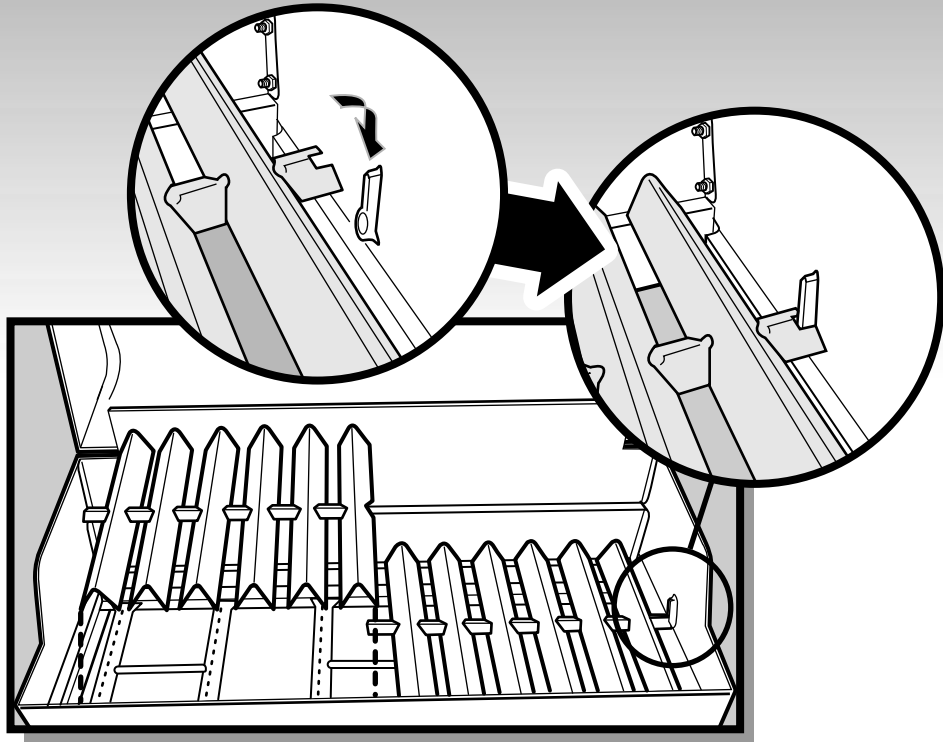

14

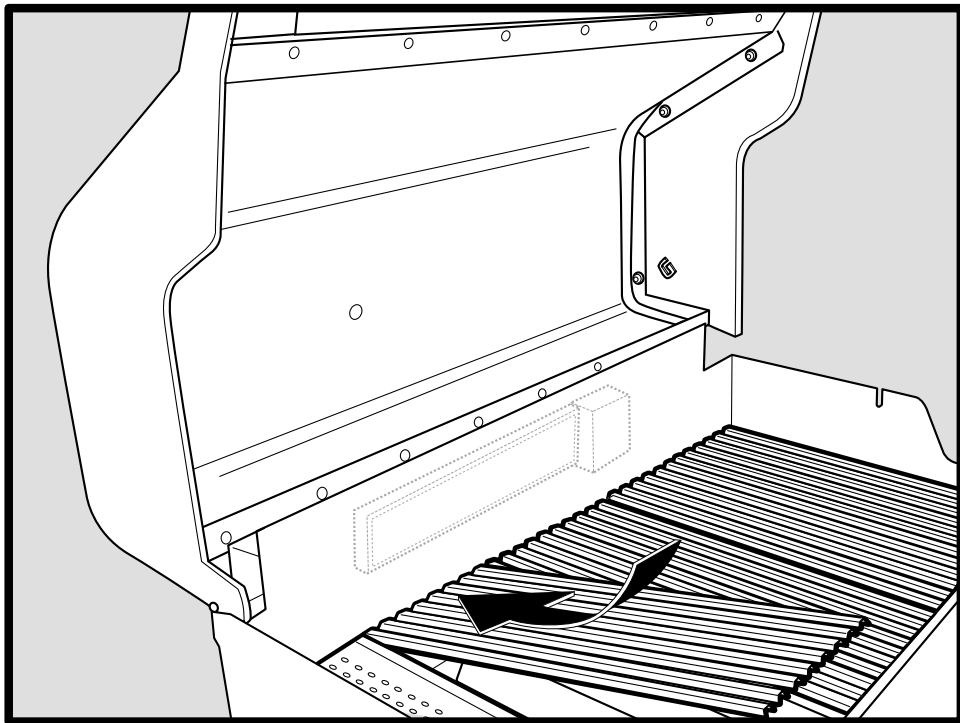



15

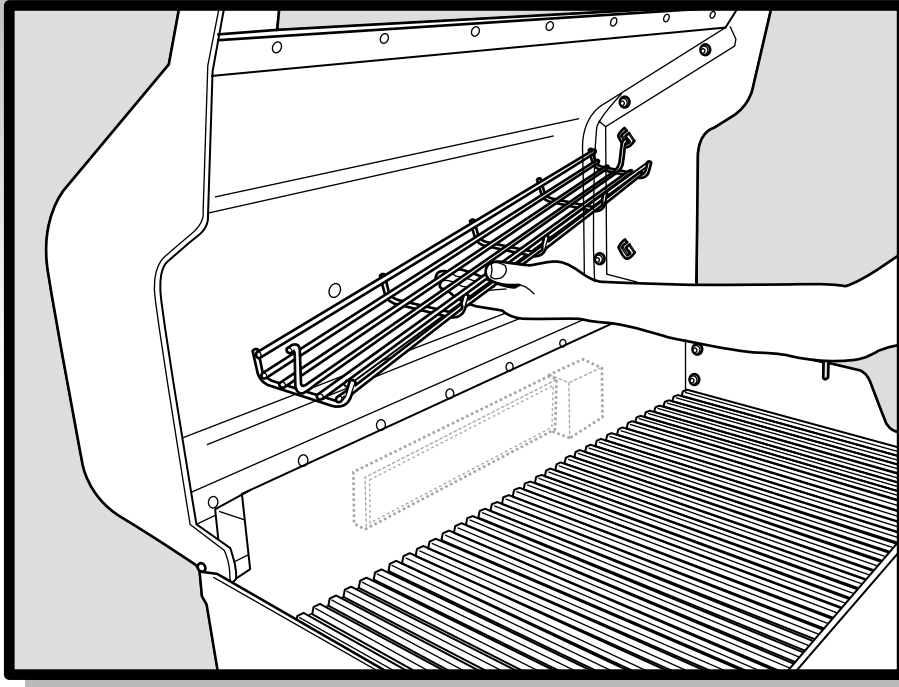

16

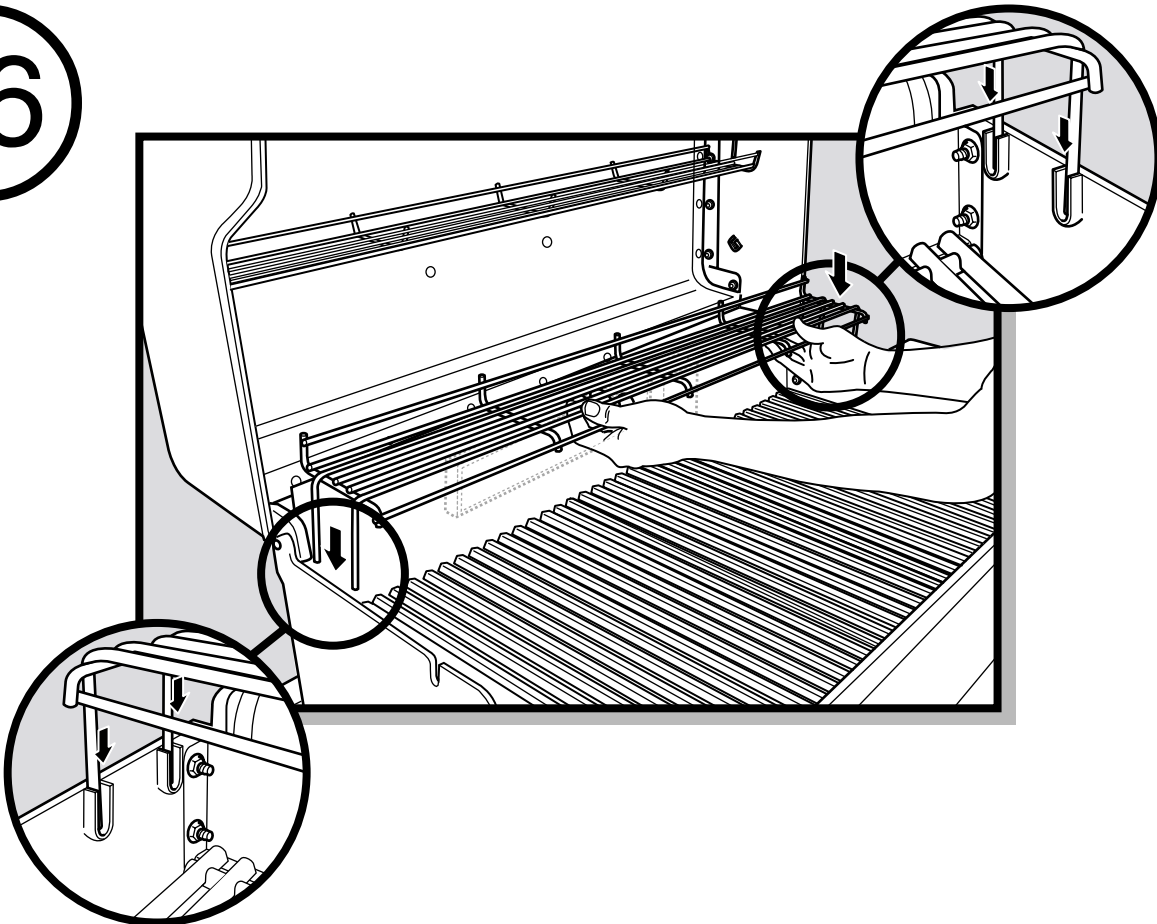



SUMMIT® SILVER A

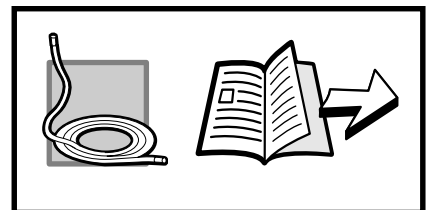
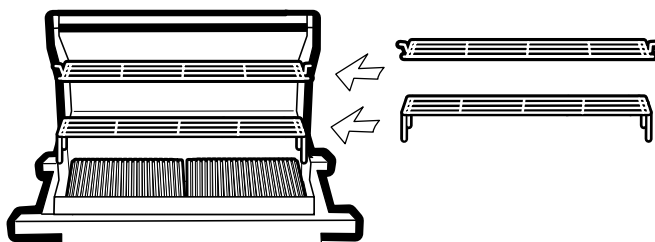
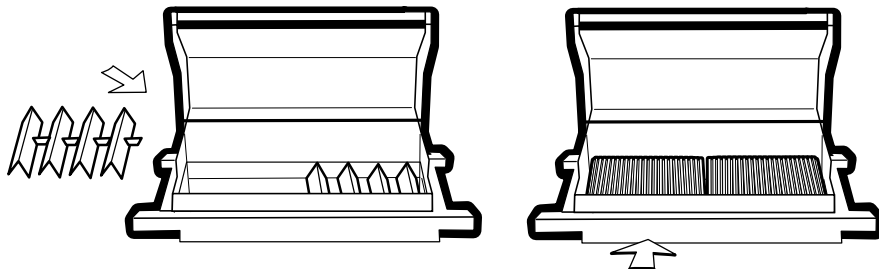
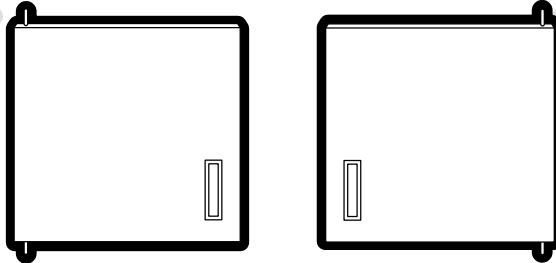
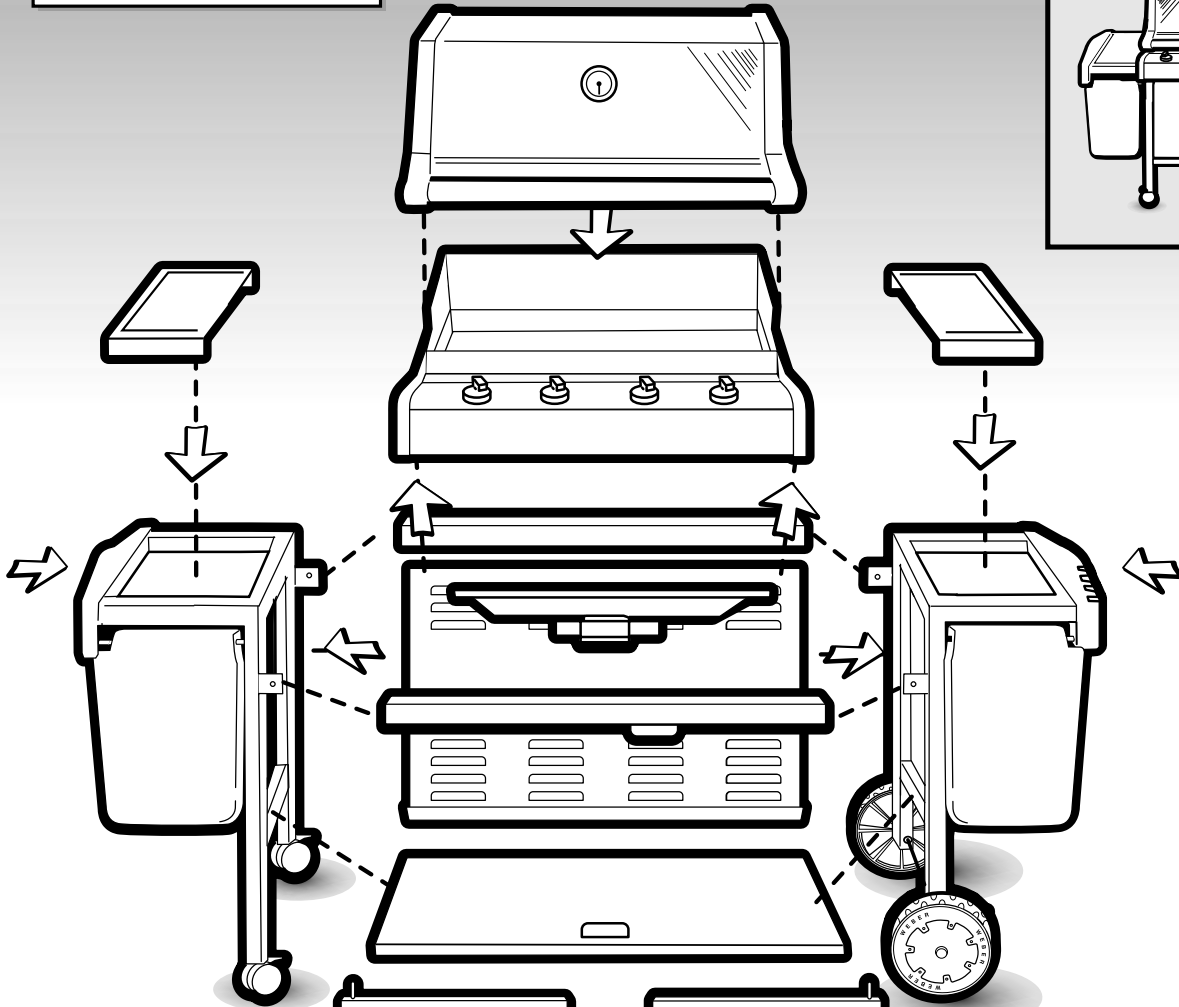
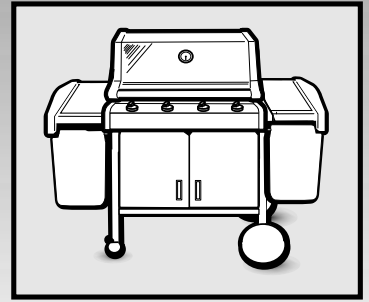



SUMMIT® GOLD A

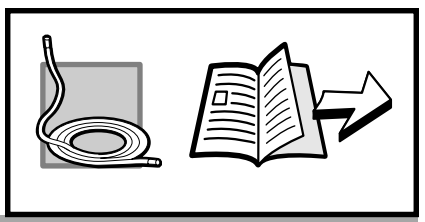
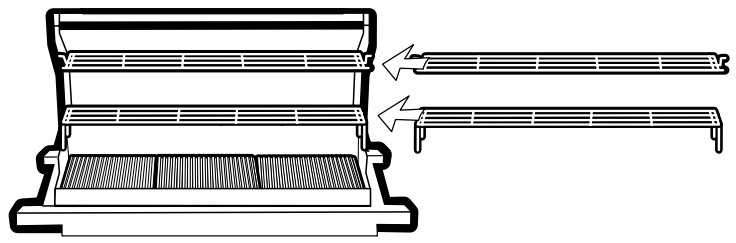
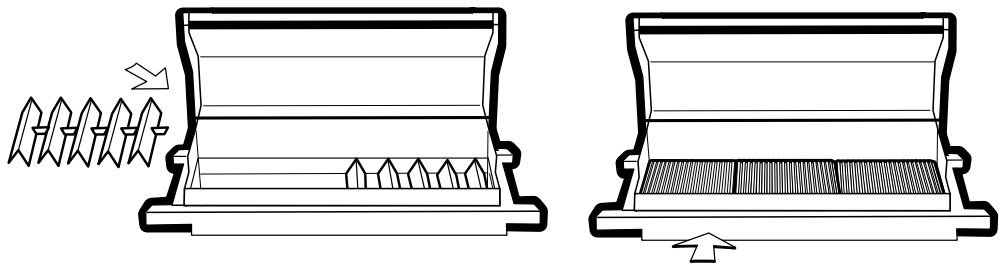
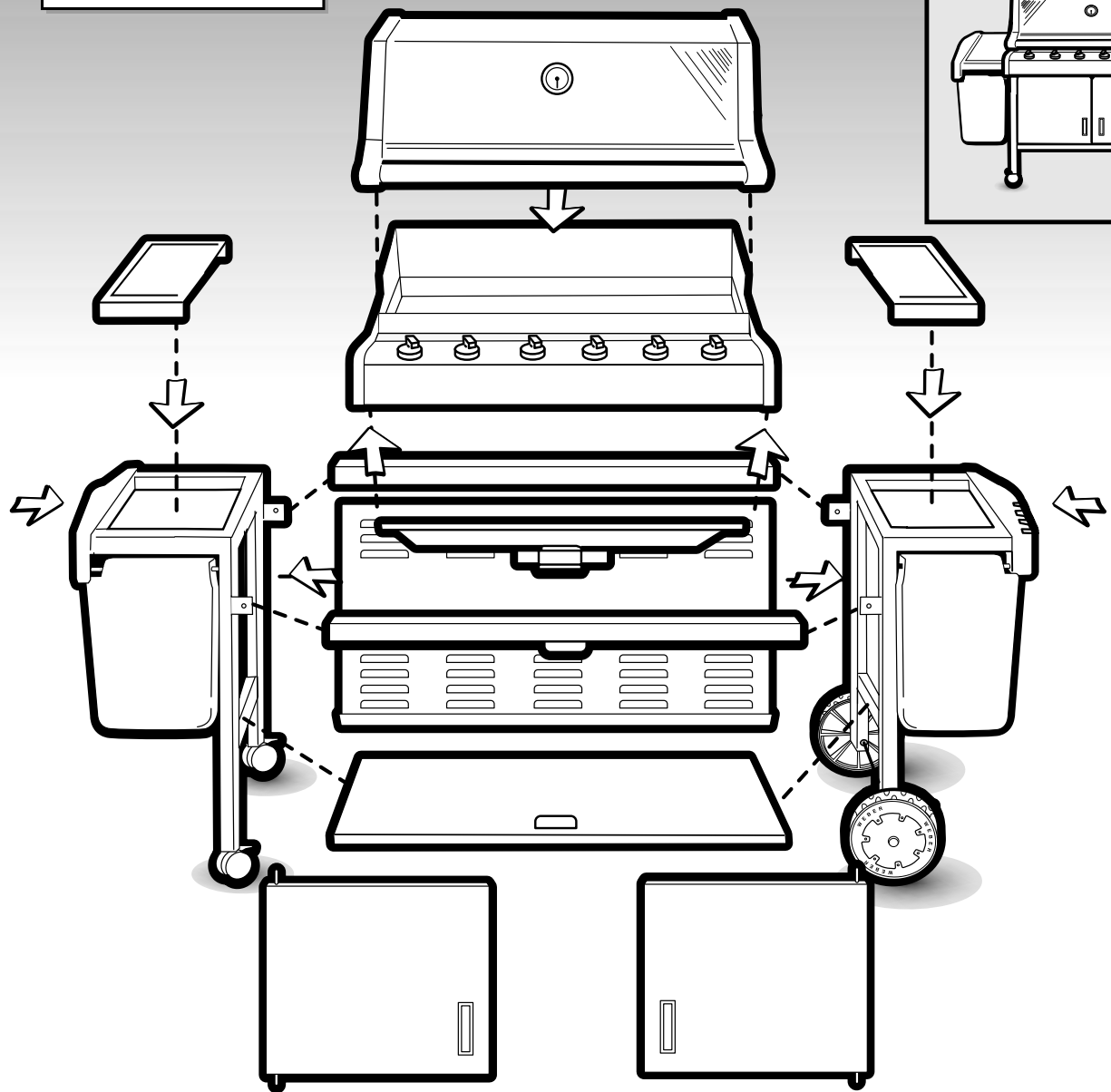
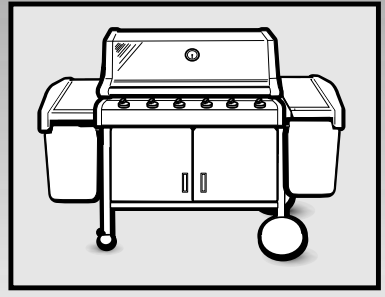

Gas Instructions

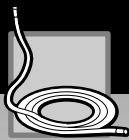

Install Gas Supply

General Specifications for Piping

Note - Contact your local municipality for building codes regulating outdoor gas barbecue installations. In absence of Local Codes, you must confirm to the latest edition of ANSI Z223.1. WE RECOMMEND THAT THIS INSTALLATION BE DONE BY A PROFESSIONAL.

Some of the following are general requirements taken from ANISI Z223.1 latest edition for complete specifications.

- This barbecue is designed to operate at 7 inches of water column pressure (.2526 psi).
- A manual shut-off valve must be installed outdoors, immediately ahead of the quick disconnect.
- An additional manual shut-off valve indoors should be installed in the branch fuel line in an accessible location near the supply line
- The quick disconnect connects to a 3/8 inch NPT thread from the gas source. The quick disconnect fitting is a hand-operated device that automatically shuts OFF the flow of gas from the source when the barbecue is disconnected
- The quick disconnect fitting can be installed horizontally, or pointing downward. Installing the fitting with the open end pointing upward can result in collecting water and debris.
- The dust covers (supplied plastic plugs) help keep the open ends of the quick disconnect fitting clean while disconnected.
- Pipe compound should be used which is resistant to the action of natural gas when connections are made.
- The outdoor connector must be firmly attached to rigid, permanent construction.

⚠ WARNING: Do not route the 12 foot hose under a deck. The hose must be visible.

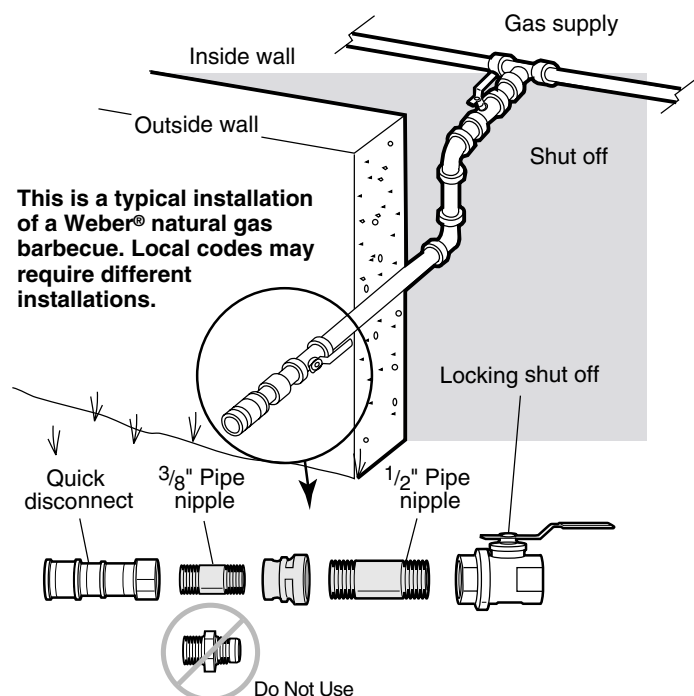

Gas Line Piping

- If the length of the line required does not exceed 50 feet, use a 5/8" O.D. tube. One size larger should be used for lengths greater than 50 feet.
- Gas piping may be copper tubing, type K or L; polyethylene plastic tube, with a minimum wall thickness of .062 inch; or standard weight (schedule 40) steel or wrought iron pipe.
- Copper tubing must be tin-lined if the gas contains more than 0.3 grams of hydrogen sulfide per 100 cubic feet of gas.
- Plastic tubing is suitable only for outdoor, underground use.
- Gas piping in contact with earth, or any other material which may corrode the piping, must be protected against corrosion in an approved manner.
- Underground piping must have a minimum of 18" cover

Test Connections

All connections and joints must be thoroughly tested for leaks in accordance with local codes and all listed procedures in the latest edition of ANSI Z223.1

⚠ DANGER

Do not use an open flame to check for gas leaks. Be sure there are no sparks or open flames in the area while you check for gas leaks. This will result in a fire or explosion which can cause serious bodily injury or death and damage to property.

Check that all burner valves are off

Valves are shipped in the OFF position, but you should check to be sure that they are turned OFF. Check by pushing down and turning clockwise. If they do not turn, they are off. Proceed to the next step. If they do turn continue turning them clockwise until they stop, then they are off. Proceed to the next step.

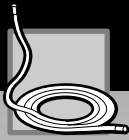

Gas Instructions

Connect Gas Supply

a) To connect gas hose at the supply: Slide back the collar of the quick disconnect. Push male fitting of the hose into the quick disconnect, and maintain pressure(1). Slide the collar closed(2). If it does not engage or lock, repeat procedure.

b) To connect gas hose at the Grill: Slide back the collar of the quick disconnect. Push male fitting of the grill connection into the quick disconnect, and maintain pressure(1). Slide the collar closed(2). If it does not engage or lock, repeat procedure.

Gas will not flow unless the quick disconnect is properly engaged.

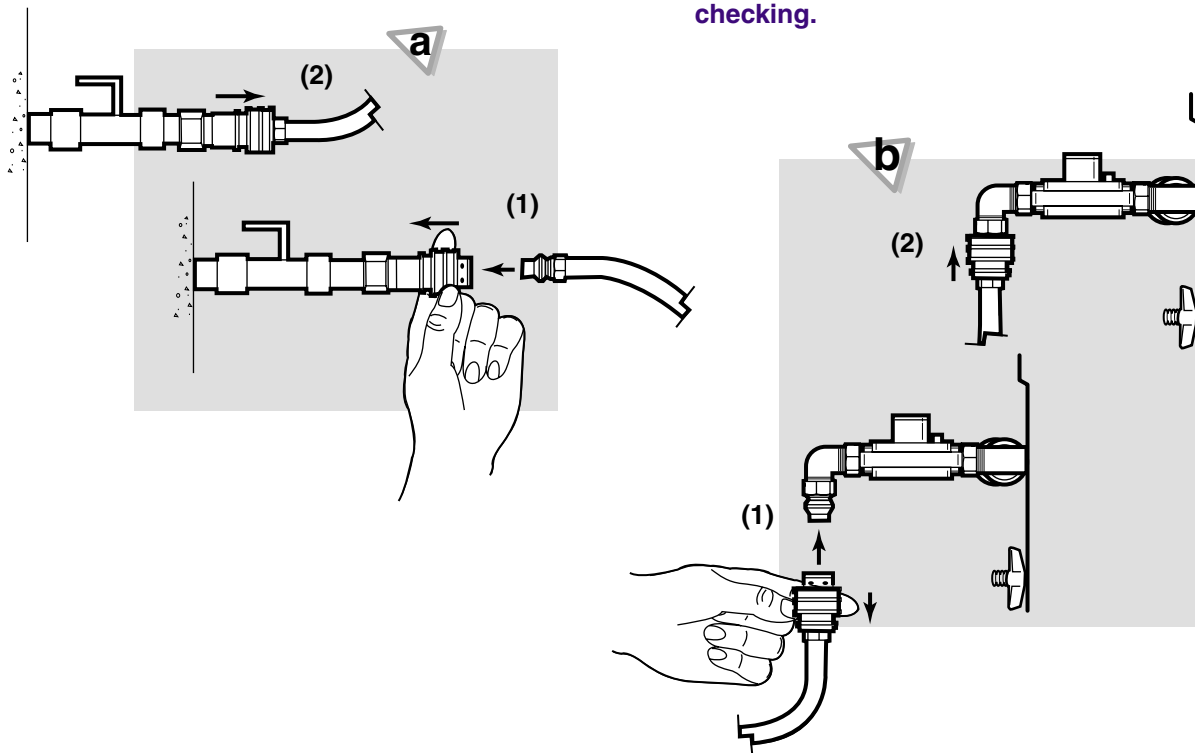

Check for Gas Leaks

⚠ DANGER

Do not use an open flame to check for gas leaks. Be sure there are no sparks or open flames in the area while you check for leaks. Sparks or open flames will result in a fire or explosion which can cause serious bodily injury or death and damage to property.

⚠ WARNING: You should check for gas leaks every time you disconnect and reconnect a gas fitting.

⚠ WARNING: Perform these leak checks even if your barbecue was dealer or store assembled.

Turn on gas supply.

Check for leaks by wetting the connections with the soap and water solution and watching for bubbles. If bubbles form or if a bubble grows, there is a leak.

Note - Since some leak test solutions, including soap and water, may be slightly corrosive, all connections should be rinsed with water after checking for leaks.

⚠ WARNING: Do not ignite burners when leak checking.

Gas Instructions

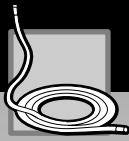

⚠WARNING : The gas connections of your Summit® gas grill have been factory tested. We do however recommend that you leak check all gas connections before operating your Summit® gas grill.

Remove control panel

Part required: Phillips Screwdriver.

Remove the burner control knobs (1). The screws (2) need to be removed from the control panel (3) before the control panel is removed from the grill.

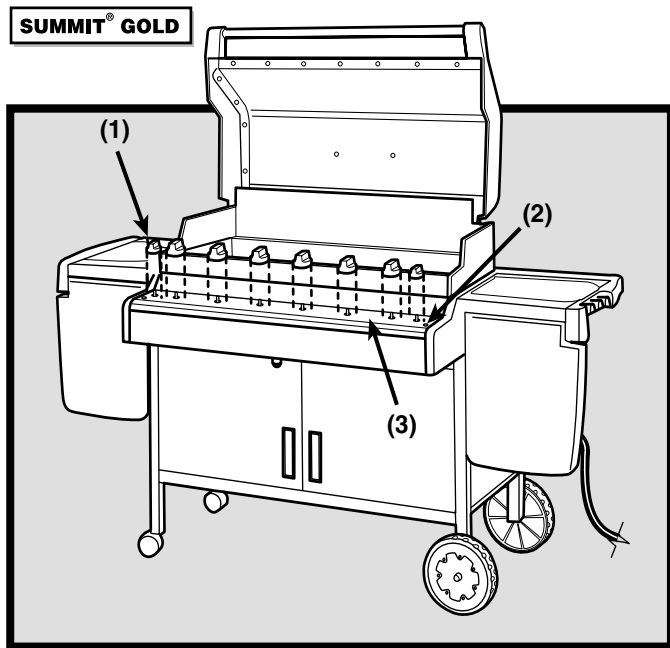
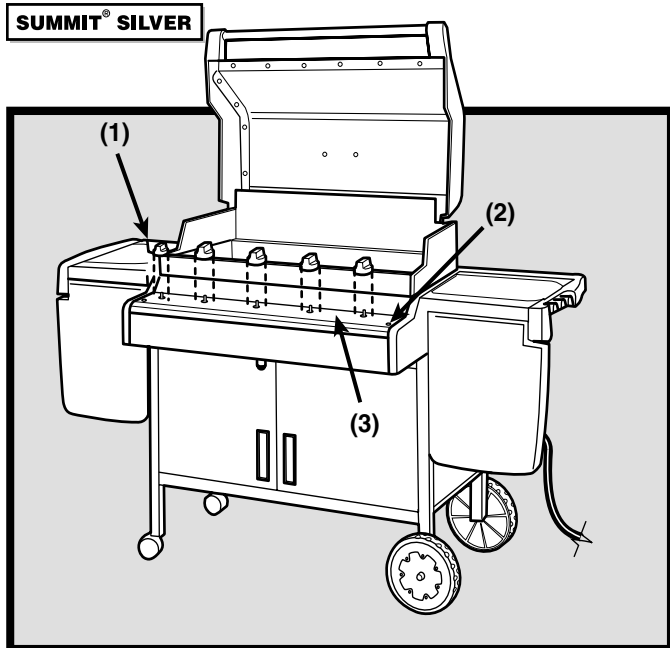

Put your fingers under the front edge of the control panel and lift off.

Completely remove the control panel (4) from the cooking box assembly exposing the valves, burners, igniter, and manifold.

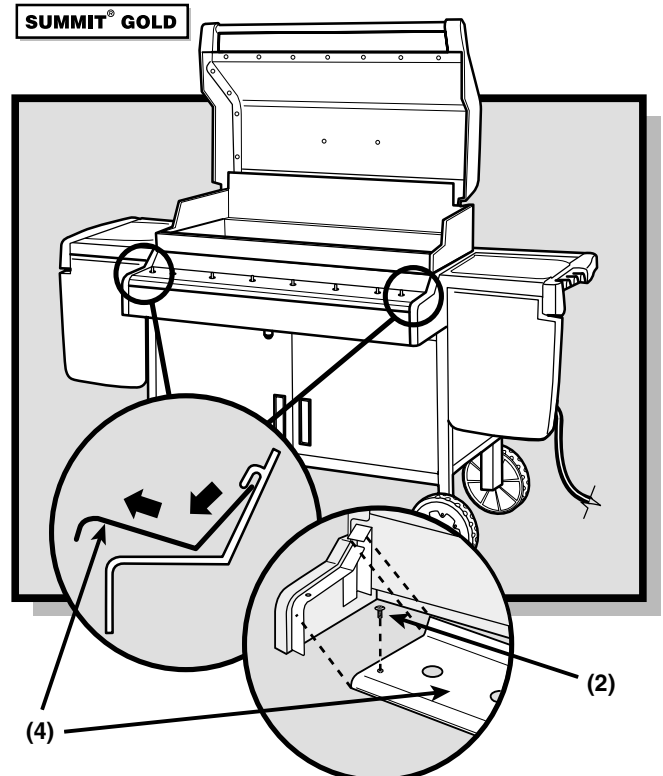
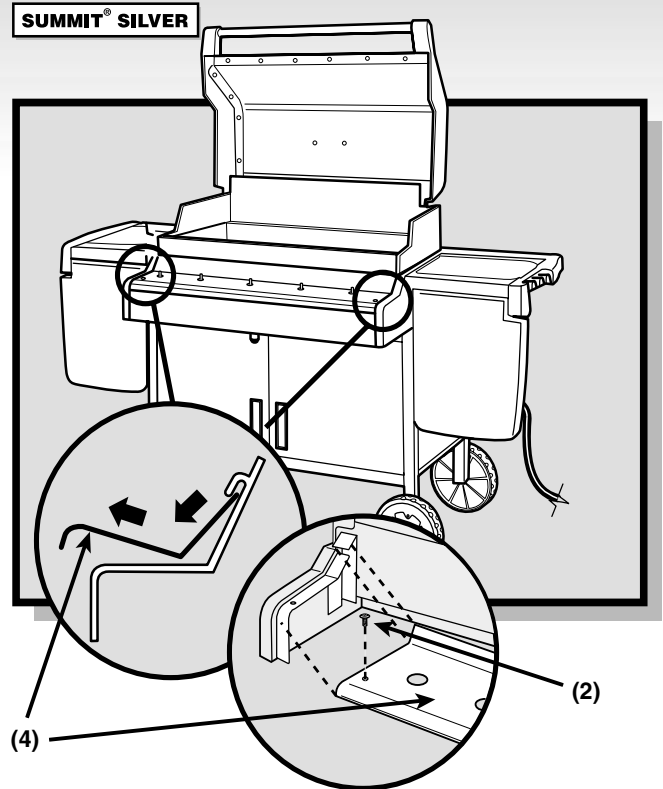

Gas Instructions



Remove the Front Panel by sliding the panel up and out of the slots.

SUMMIT® SILVER

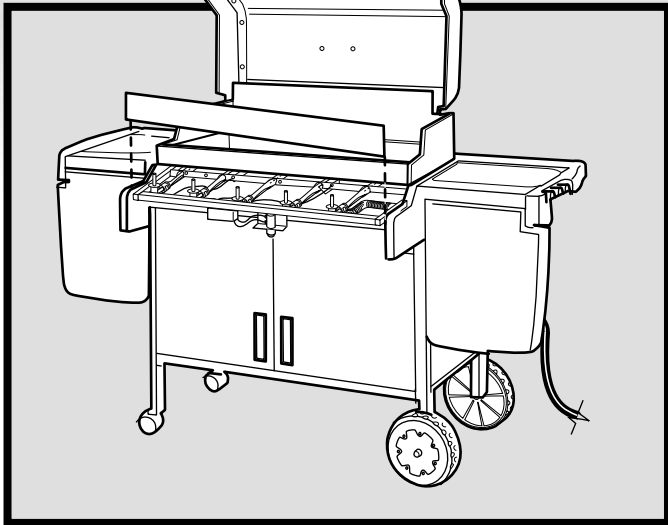

SUMMIT® GOLD

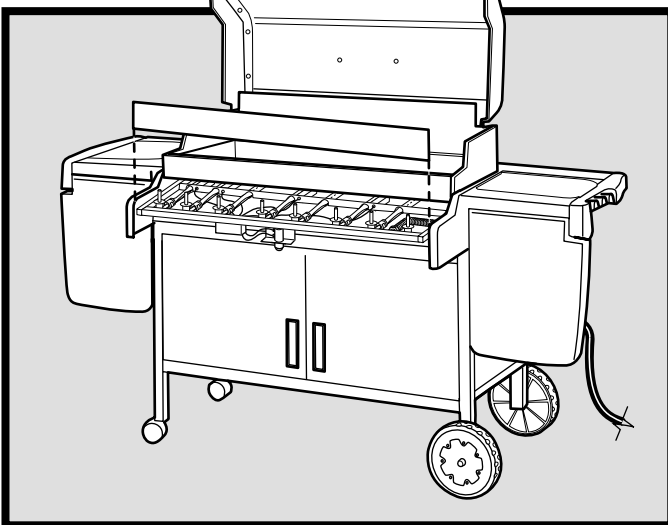

Check for gas leaks

⚠ DANGER

Do not use an open flame to check for gas leaks. Be sure there are no sparks or open flames in the area while you check for leaks. Sparks or open flames will result in a fire or explosion which can cause serious bodily injury or death and damage to property.

⚠ WARNING: You should check for gas leaks every time you disconnect and reconnect a gas fitting.

Note - All factory-made connections have been thoroughly checked for gas leaks. The burners have been flame-tested. As a safety precaution however, you should recheck all fittings for leaks before using your Weber® gas barbecue. Shipping and handling may loosen or damage a gas fitting.

⚠ WARNING: Perform these leak checks even if your barbecue was dealer or store assembled.

You will need: a soap and water solution, and a rag or brush to apply it.

To perform leak checks: Slide back the collar of the quick disconnect. Push male fitting of the hose into the quick disconnect, and maintain pressure(1). Slide the collar closed(2). If it does not engage or lock, repeat procedure. Gas will not flow unless the quick disconnect is properly engaged.

Turn on gas supply.

Check for leaks by wetting the connections with the soap and water solution and watching for bubbles. If bubbles form or if a bubble grows, there is a leak.

Note - Since some leak test solutions, including soap and water, may be slightly corrosive, all connections should be rinsed with water after checking for leaks.

⚠ WARNING: Do not ignite burners when leak checking.

Gas Instructions

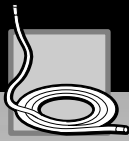

Check:

- 1) Quick disconnect hose to grill connection
- 2) Valve to manifold connection
- 3) Hose to quick disconnect connection (gas supply)

⚠ WARNING: If there is a leak at connections (1),(2), or (3) turn OFF the gas. DO NOT OPERATE THE GRILL. Contact the Customer Service Representative in your region using the contact information sheet provided with your manual.

When leak checks are complete, turn gas supply OFF at the source and rinse connections with water.

- 4) Gas line to manifold connections.

⚠ WARNING: If there is a leak at connection (4), retighten the fitting with a wrench and recheck for leaks with soap and water solution.

If a leak persists after retightening the fitting, turn OFF the gas. DO NOT OPERATE THE GRILL. Contact the Customer Service Representative in your region using the contact information sheet provided with your manual.

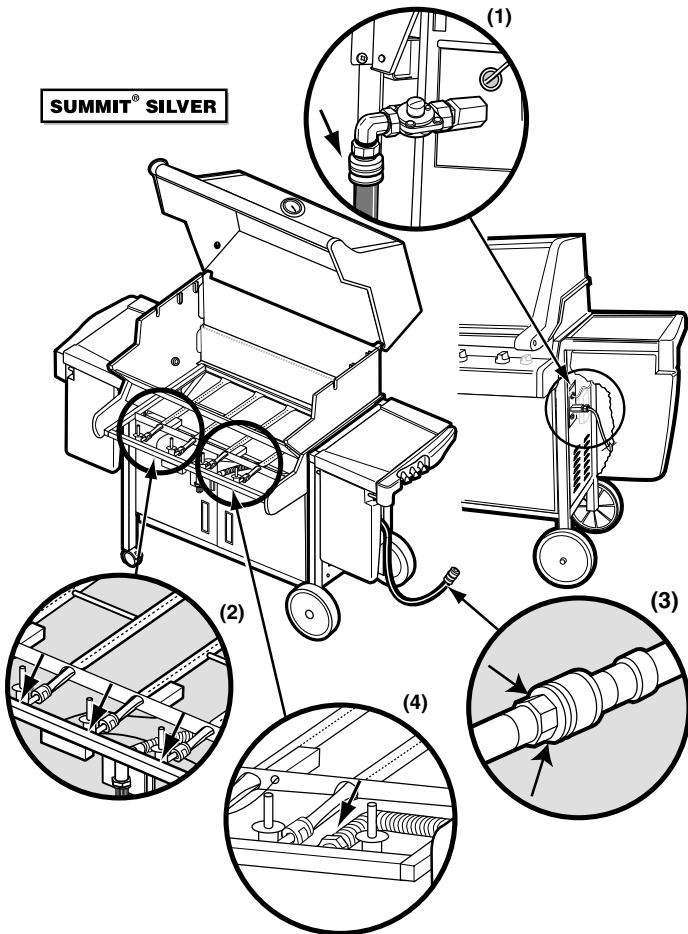
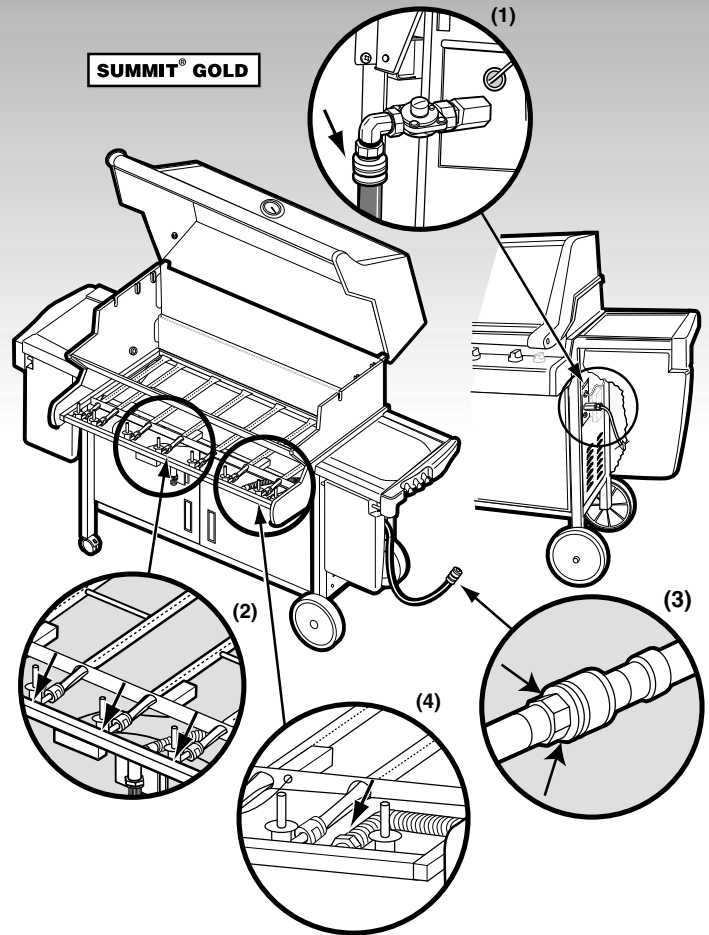



Gas Instructions

Reinstall control panel

Parts required: control panel, screws, and burner control knobs.

Place the control panel back onto the control panel brackets on either side of the front of the cooking box. Line up screws with screw holes on both the control panel and control panel brackets. Tighten screws. Reinstall burner control knobs & igniter wires (if necessary). Place corresponding control knobs down onto the valve stems. From the underside of the control panel, replace the two wires (1, 2) of each igniter.

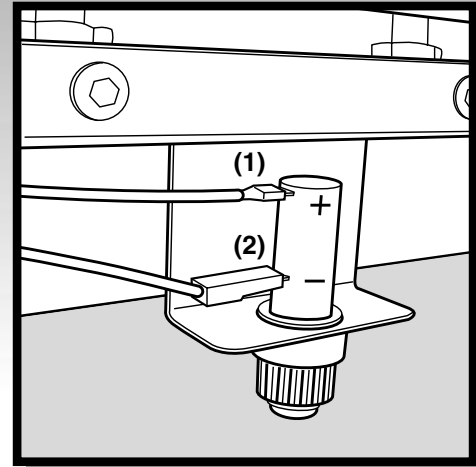

SUMMIT® SILVER

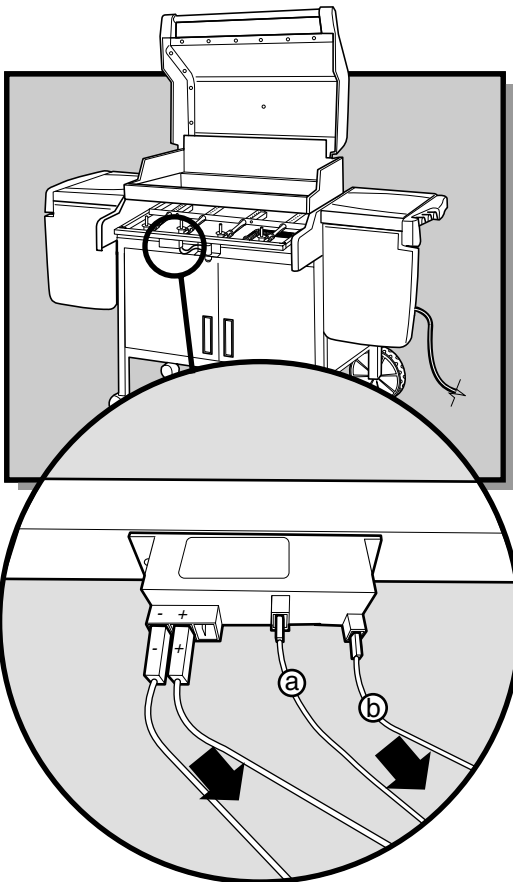

a = Yellow Tab with Black Wire
b = White Tab with Black Wire

SUMMIT® GOLD

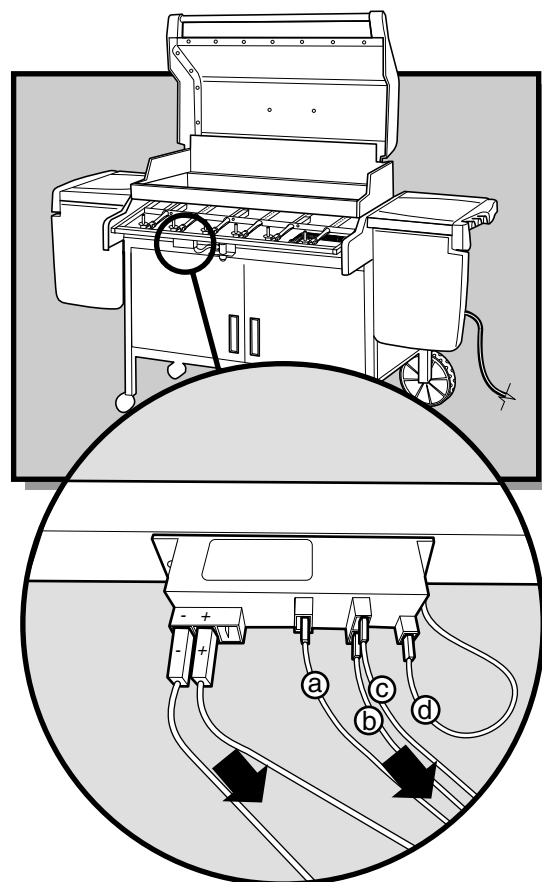

a = Yellow Tab with Black Wire
b = White Tab with Black Wire
c = Green Tab with Black Wire
d = Grounding Wire



Operating Instructions

Grilling Methods

NOTE: If grill loses heat while cooking refer to the troubleshooting section of this manual.

You can adjust the Left and Right burners in each burner set as desired. The control settings are High (H), Medium (M), Low (L), or Off (O).

If burners go out during cooking, turn off all burners and wait 5 minutes before relighting.

⚠WARNING: Check the bottom tray and catch pan for grease build-up before each use. Remove excess grease to avoid a grease fire in the bottom tray.

Preheating the grill before grilling is important. Light your Summit® gas grill according to the instructions in this Owner's Manual. **Turn both burners in each burner set to High (HH), close the lid, and preheat grill with the lid down until grill thermometer reaches 550°F. This is the recommended broiling temperature.**

Preheating

Preheating the grill before grilling is very important. Light your Summit® gas grill according to the instructions in your Owner's Manual. Close the lid and wait until the thermometer in your lid reaches 500°-550°F (260°-288°C). This will take approximately 10 to 15 minutes, depending on outside temperatures.

Covered cooking

All grilling is done with the lid down to provide uniform, evenly circulated heat. With the lid closed, the Summit® gas grill cooks much like a convection oven. The thermometer in the lid indicates the cooking temperature inside the grill. All preheating and grilling is done with the lid down. No peeking — heat is lost every time you lift the lid.

Flavorizer® system

When meat juices drip from the food onto the specially angled Flavorizer® bars, they create smoke that gives foods an irresistible barbecued flavor. Thanks to the unique design of the burners, Flavorizer® bars and the flexible temperature controls, uncontrolled flare-ups are virtually eliminated, because YOU control the flames. Because of the special design of the Flavorizer® bars and burners, excess fats are directed through the funnel-shaped bottom tray into the grease catch pan.

The most important thing to know about grilling is which cooking method to use for a specific food, Direct or Indirect. The difference is simple: place the food directly over the fire, or arrange the fire on either side of it. Using the right method is the shortest route to great results—and the best way to ensure doneness safety.

Direct cooking

The Direct Method, similar to broiling, means the food is cooked directly over the heat source. For even cooking, food should be turned once halfway through the grilling time.

Use the Direct method for foods that take less than 25 minutes to cook: steaks, chops, kabobs, sausages, vegetables, and more.

Direct cooking is also necessary to sear meats. Searing creates that wonderful crisp, caramelized texture where the food hits the grate. It also adds great color and flavor to the entire surface. Steaks, chops, chicken breasts, and larger cuts of meat all benefit from searing.

To sear meats, place them over Direct High heat for 2 to 5 minutes per side. Smaller pieces require less searing time. Usually after searing you finish cooking the food at a lower temperature. You

can finish cooking fast-cooking foods by the Direct method; use

the Indirect method for longer-cooking foods.

To set up your gas grill for Direct cooking, preheat the grill with all burners on High. Place food on the cooking grate, and then adjust all burners to the temperature noted in the recipe. Close the lid of the grill and lift it only to turn food or to test for doneness at the end of the recommended cooking time.

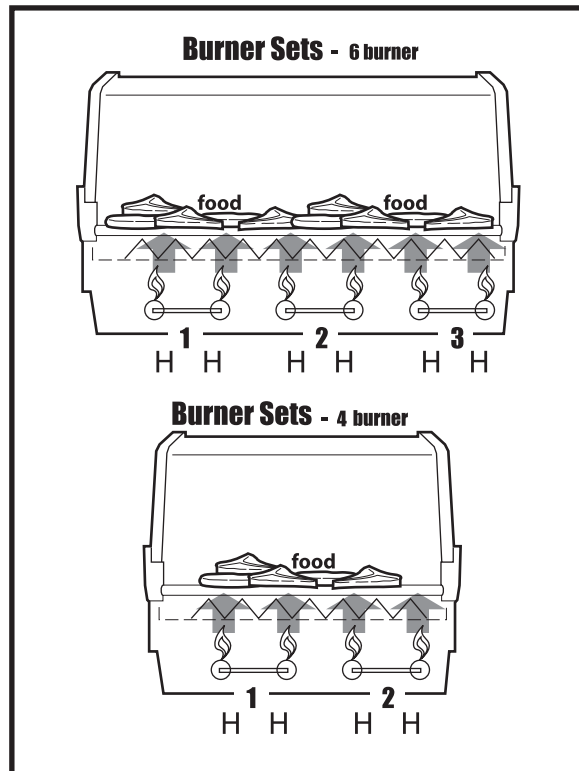

Direct Method

Food is placed on the area of the cooking grates directly over the lit burners.



Operating Instructions

Indirect cooking

The Indirect Method is similar to roasting, but with the added benefits of that grilled texture, flavor, and appearance you can't get from an oven. To set up for Indirect cooking, gas burners are lit on either side of the food but not directly beneath it. Heat rises, reflects off the lid and inside surfaces of the grill, and circulates to slowly cook the food evenly on all sides, much like a convection oven, so there's no need to turn the food.

Use the Indirect method for foods that require 25 minutes or more of grilling time or that are so delicate that direct exposure to the flame would dry them out or scorch them. Examples include roasts, ribs, whole chickens, turkeys, and other large cuts of meat, as well as delicate fish fillets.

To set up your gas grill for Indirect cooking, preheat the grill with all burners on High. Then adjust the burners on each side of the food to the temperature noted in the recipe and turn off the burner(s) directly below the food. For best results, place roasts, poultry, or large cuts of meat on a roasting rack set inside a disposable heavy-gauge foil pan. For longer cooking times, add water to the foil pan to keep drippings from burning. The drippings can be used to make gravies or sauces.

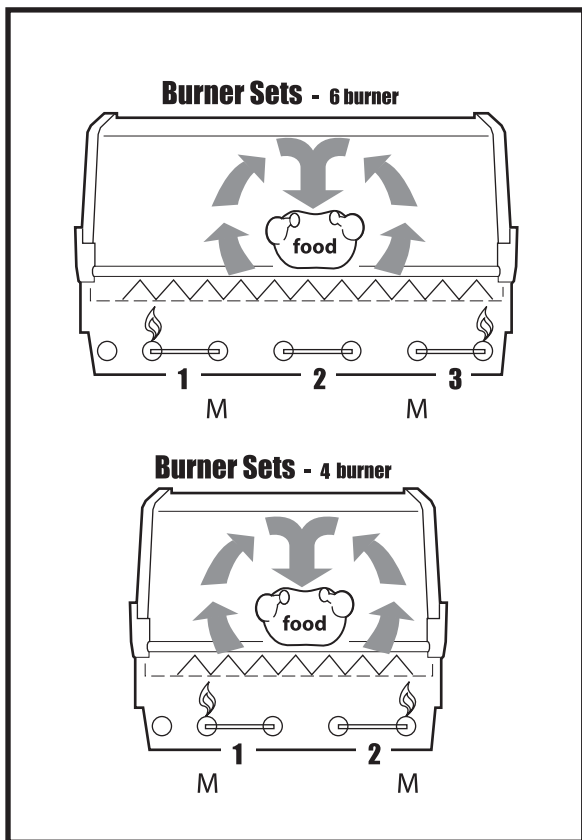

Indirect Method

Food is placed on the area of the cooking grates between the lit burners.

Grilling Tips & Helpful Hints

- Always preheat the grill before cooking. Set all burners on HIGH heat and close lid; heat for 10 minutes, or until thermometer registers 500°-550°F (260°-288°C).
- Sear meats and cook with the lid down for perfectly grilled food every time.
- Grilling times in recipes are based on 70°F (20°C) weather and little or no wind. Allow more cooking time on cold or windy days, or at higher altitudes. Allow less cooking time in extremely hot weather.
- Grilling times in charts and recipes are approximate. Times can vary because of the weather, or the amount, size and shape of the food being grilled.
- The temperature of your Summit® gas grill may run hotter than normal for the first few uses.
- Grilling conditions may require the adjustment of the burner controls to attain the correct cooking temperatures.
- In general, large pieces of meat will require more cooking time per pound than small pieces of meat. Foods on a crowded cooking grate will require more cooking time than just a few foods. Foods grilled in containers, such as baked beans, will require more time if grilled in a deep casserole rather than a shallow baking pan.
- Trim excess fat from steaks, chops and roasts, leaving no more than a scant 1/4 inch of fat. Less fat makes cleanup easier, and is a virtual guarantee against unwanted flare-ups.
- Foods placed on the cooking grate directly above burners may require turning or moving to a less hot area.
- Use tongs rather than a fork for turning and handling meats to avoid losing natural juices. Use two spatulas for handling large whole fish.
- If an unwanted flare-up should occur, turn all burners to OFF and move food to another area of the cooking grate. Any flames will quickly subside. After flames subside, relight the grill. **NEVER USE WATER TO EXTINGUISH FLAMES ON A GAS GRILL.**
- Some foods, such as a casserole or thin fish fillets, will require a container for grilling. Disposable foil pans are very convenient, but any metal pan with ovenproof handles can also be used.
- Always be sure the bottom tray and grease catch pan are clean and free from debris.
- Do not line the funnel-shaped bottom tray with foil. This could prevent the grease from flowing into the grease catch pan.
- Using a timer will help to alert you when "well-done" is about to become "over-done."



Operating Instructions

Lighting

Summary lighting instructions are on the control panel.

⚠ DANGER

Failure to open the lid while igniting the barbecue's burners, or not waiting 5 minutes to allow the gas to clear if the barbecue does not light, may result in an explosive flame-up which can cause serious bodily injury or death.

Crossover® Ignition System

Note - The Crossover® ignition system ignites the set of left burners with a spark from the igniter electrode inside the Gas Catcher™ ignition chamber. You generate the energy for the spark by pushing the electronic ignition button.

⚠ **WARNING:** Check hose before each use of barbecue for nicks, cracking, abrasions or cuts. If the hose is found to be damaged in any way, do not use the barbecue. Replace using only Weber® authorized replacement hose. Contact the Customer Service Representative in your region using the contact information sheet provided with your manual.

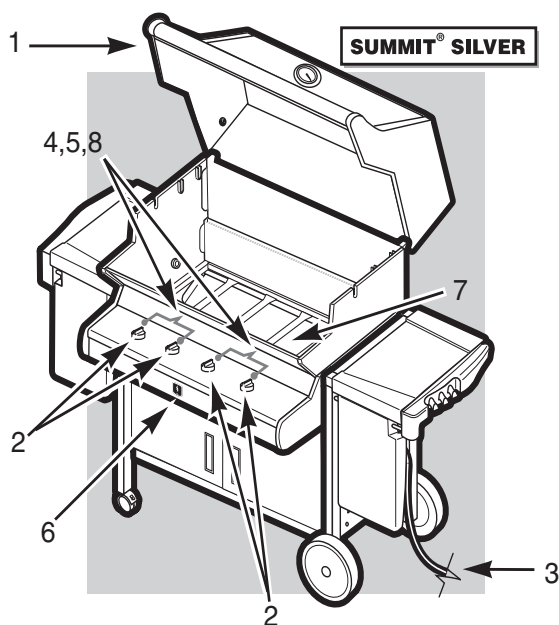

*The grill illustrated may have slight differences than the model purchased.

SUMMIT® GOLD

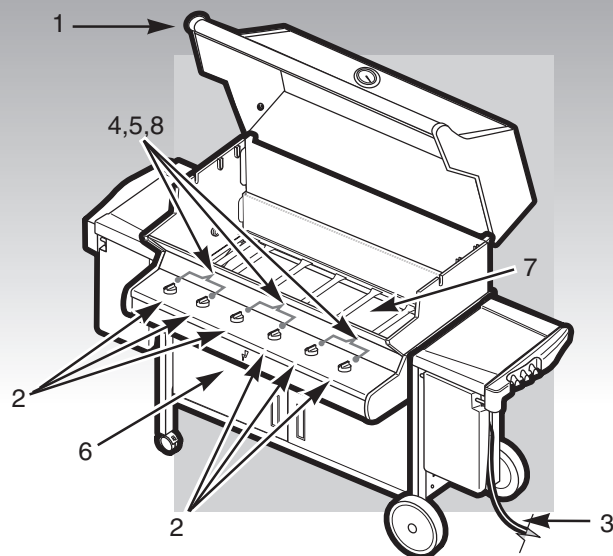

*The grill illustrated may have slight differences than the model purchased.

- 1) Open the lid.
- 2) Make sure all burner control knobs are turned OFF. (Push each burner control knob down and turn clockwise to ensure that they are in the off position.)
- 3) Turn the gas supply valve on.

⚠ **WARNING:** Do not lean over the open grill while lighting.

- 4) Select the burner set you want to operate.
- 5) Push LEFT burner control knob down and turn to START/HI in selected burner set.
- 6) Push igniter button and hold until burner ignites. You will hear the igniter sparker.
- 7) Check that the burner is lit by looking through the cooking grates. You should see a flame.

⚠ **WARNING:** If the burner does not light, turn the LEFT burner control knob to OFF and wait 5 minutes to let the gas clear before you try again or try to light with a match.

- 8) After the LEFT burner is lit you can turn on the RIGHT burner adjacent to it. The RIGHT burner lights from the LEFT burner.

To Extinguish

Push down and turn each burner control knob clockwise to the OFF position. Turn gas supply OFF at the source.



Operating Instructions

Manual Lighting

⚠ DANGER

Failure to open lid while igniting the barbecue's burners, or not waiting 5 minutes to allow the gas to clear if the barbecue does not light, may result in an explosive flame-up which can cause serious bodily injury or death.

- 1) Open the lid.
- 2) Make sure all burner control knobs are turned OFF. (Push each burner control knob down and turn clockwise to ensure they are in the off position.)
- 3) Turn the gas supply valve on.
- 4) Put match in the match holder and strike match.
- 5) Push LEFT burner control knob down and turn to START/HI.
- 6) Insert match holder and lit match down through cooking grates and Flavorizer® bars to ignite LEFT burner in each selected burner set.

SUMMIT® SILVER

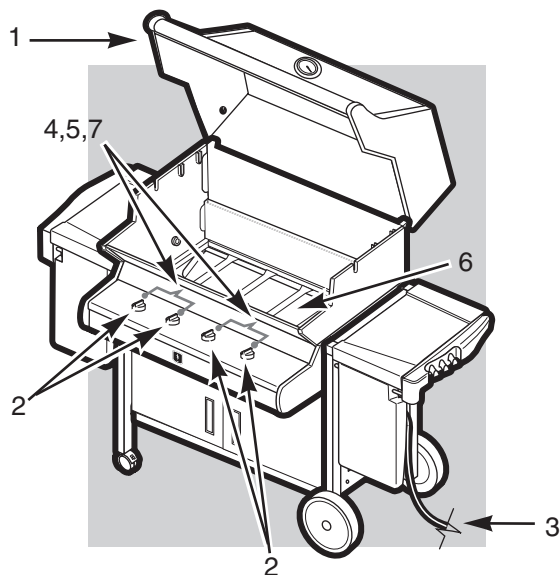

*The grill illustrated may have slight differences than the model purchased.

SUMMIT® GOLD

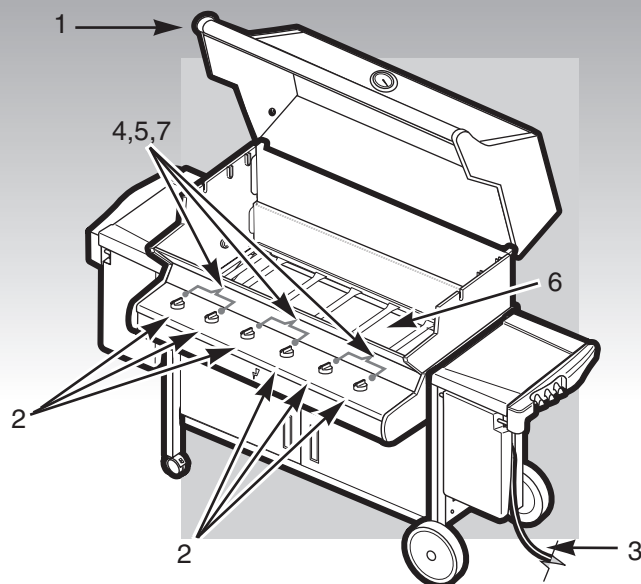

*The grill illustrated may have slight differences than the model purchased.

- ⚠ **WARNING:** If the burner does not light, turn the LEFT burner control knob to OFF and wait 5 minutes to let the gas clear before you try again.
- 7) After LEFT burner is lit you can turn on the RIGHT burner adjacent to it. The RIGHT burner lights from the LEFT burner.

To Extinguish

Push down and turn each burner control knob clockwise to the OFF position. Turn gas supply OFF at the source.



Main Burner Troubleshooting

Problem	Check	Cure
Burners burn with a yellow or orange flame, in conjunction with the smell of gas.	Inspect Weber® Insect/Spider Screens for possible obstructions. (Blockage of holes.)	Clean Weber® Insect/Spider Screens. (See Section “Annual Maintenance”)
Burner does not light, or flame is low in HIGH position.	Is fuel hose bent or kinked?	Straighten fuel hose.
	Does the Left burner light with a match?	If you can light the Left burner with a match, then check the Crossover® ignition system.
Experiencing flare-ups: ⚠ CAUTION: Do not line the bottom tray with aluminum foil.	Are you preheating barbecue in the prescribed manner?	All burners on high for 10 to 15 minutes for preheating.
	Are the cooking grates and Flavorizer® bars heavily coated with burned-on grease?	Clean thoroughly. (See Section “Cleaning”)
	Is the bottom tray “dirty” and not allowing grease to flow into catch pan?	Clean bottom tray
Burner flame pattern is erratic. Flame is low when burner is on HIGH. Flames do not run the whole length of the burner tube.	Are burners clean?	Clean burners. (See Section “Maintenance”.)
Inside of lid appears to be “peeling.” (Resembles paint peeling.)	The lid is stainless steel, not paint. It cannot “peel”. What you are seeking is baked on grease that has turned to carbon and is flaking off. THIS IS NOT A DEFECT.	Clean thoroughly. (See Section “Cleaning”.)
If problems cannot be corrected by using these methods, please contact the Customer Service Representative in your region using the contact information sheet provided with your manual.		

Maintenance

Weber® Spider /Insect screens

Your Weber® gas barbecue, as well as any outdoor gas appliance, is a target for spiders and other insects. They can nest in the venturi section(1) of the burner tubes. This blocks the normal gas flow, and can cause the gas to flow back out of the air shutter. This could result in a fire in and around the air shutters, under the control panel, causing serious damage to your barbecue.

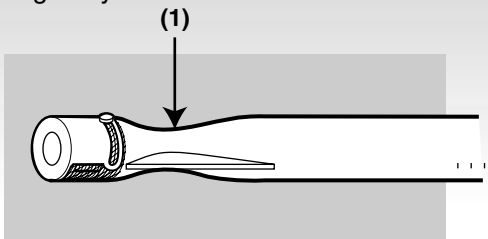

The burner tube air shutter is fitted with a stainless steel screen(1) to prevent spiders and other insects access to the burner tubes through the air shutter openings.

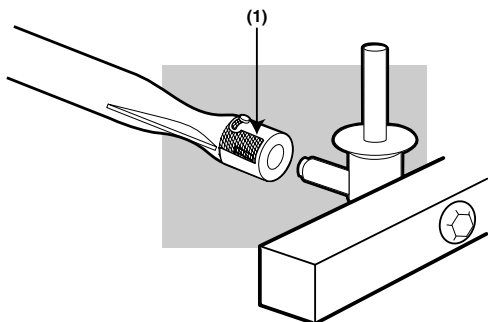

We recommend that you inspect the Spider/Insect screens at least once a year. (See Section “Annual Maintenance”.) Also inspect and clean the the Spider/Insect screens if any of the following symptoms should ever occur:

- 1) The smell of gas in conjunction with the burner flames appearing yellow and lazy.
- 2) Barbecue does not reach temperature.
- 3) Barbecue heats unevenly.
- 4) One or more of the burners do not ignite.

⚠ DANGER

Failure to correct the above mentioned symptoms may result in a fire, which can cause serious bodily injury or death, and cause damage to property.

Annual Maintenance

Inspection and cleaning of the Spider/Insect screens

To inspect the spider/insect screens, remove the control panel. If there is dust or dirt on the screens, remove the burners for cleaning the screens.

Brush the spider/insect screens, lightly, with a soft bristle brush (i.e. an old toothbrush).

⚠ **CAUTION: Do not clean the spider/insect screens with hard or sharp tools. Do not dislodge the spider/insect screens or enlarge the screen openings.**

Lightly tap the burner to get debris and dirt out of the burner tube. Once the spider/insect screens and burners are clean replace the burners.

If the spider/insect screen becomes damaged or cannot be cleaned, call Weber-Stephen Products Customer Service for replacement parts.

Main Burner Flame Pattern

The Weber® gas barbecue burners have been factory set for the correct air and gas mixture. The correct flame pattern is shown.

- 1) Burner tube
- 2) Tips occasionally flicker yellow
- 3) Light blue
- 4) Dark blue

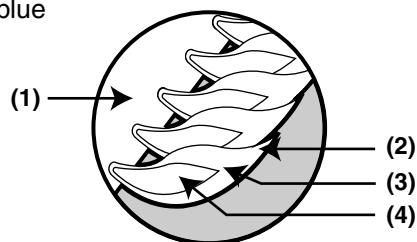

If the flames do not appear to be uniform throughout the burner tube, follow the burner cleaning procedures.

Main Burner Cleaning Procedure

Turn off the gas supply. Remove the manifold. Look inside each burner with a flashlight.

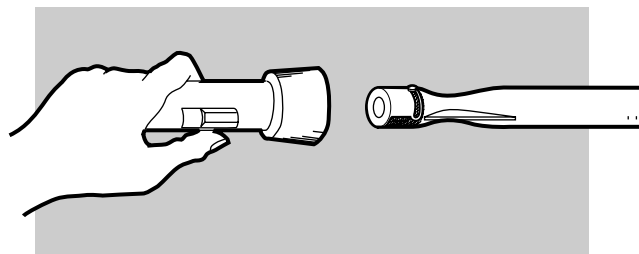

Clean the inside of the burners with a wire (a straightened-out coat hanger will work). Check and clean the air shutter opening at the ends of the burners. Check and clean the valve orifices at the base of the valves. Use a Steel bristle brush to clean outside of burners. This is to make sure all the burner ports are fully open.

⚠ **CAUTION: Do not enlarge the burner ports when cleaning.**

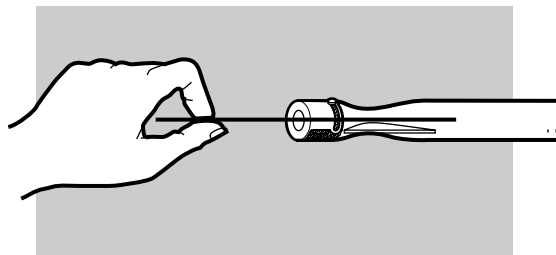

Maintenance

Replacing Main Burners

1. Your Summit® gas grill must be OFF and cool.
2. Turn gas OFF at source.
3. Disconnect regulator.
4. Remove cooking grates.
5. Remove Smoker box.
6. Remove Flavorizer® bars.
7. To remove control panel refer to “Remove the control panel” under “Check for Gas Leaks.”
8. Disconnect all ignition wires from the Ignition Module.

SUMMIT® SILVER

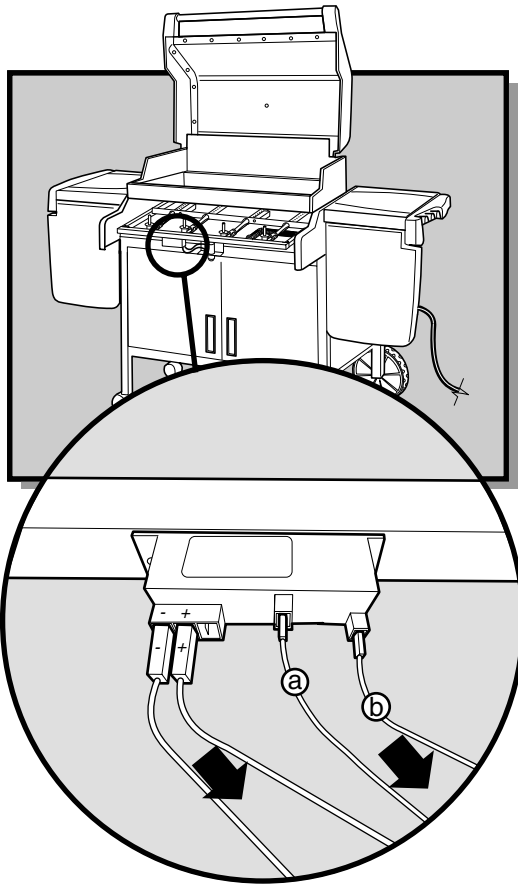

a = Yellow Tab with Black Wire
b = White Tab with Black Wire

SUMMIT® GOLD

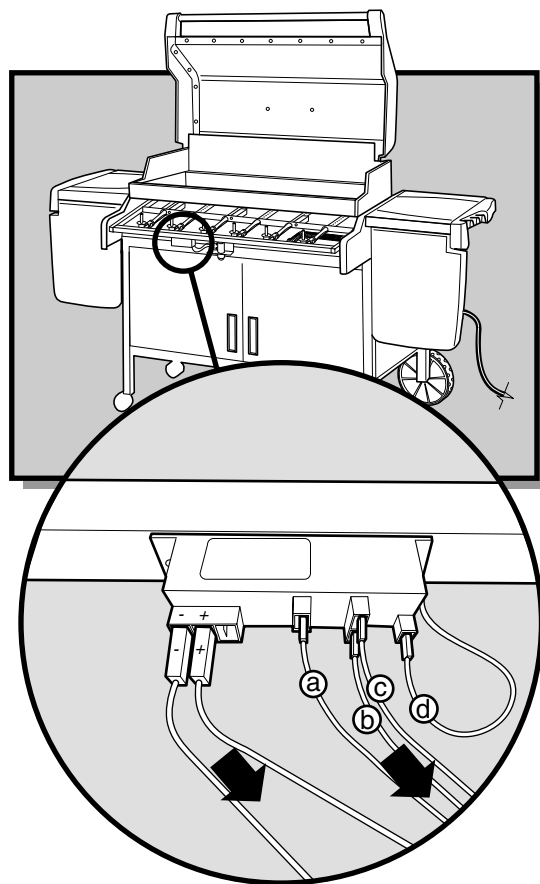

a = Yellow Tab with Black Wire
b = White Tab with Black Wire
c = Green Tab with Black Wire
d = Grounding Wire

Maintenance

9. Remove screws from the manifold assembly:
(a) Locate the screws on both sides of the manifold frame. (b) Remove the screws from manifold frame.

SUMMIT® SILVER

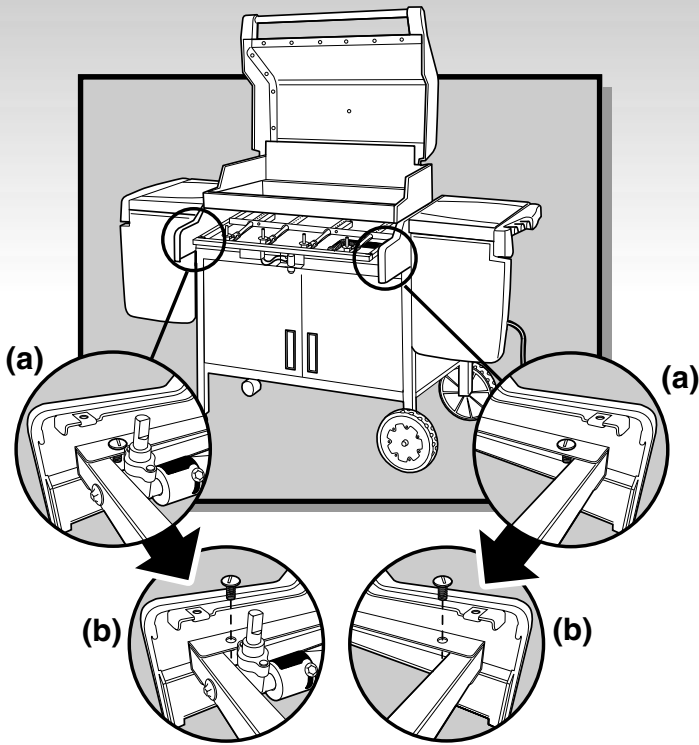

SUMMIT® GOLD

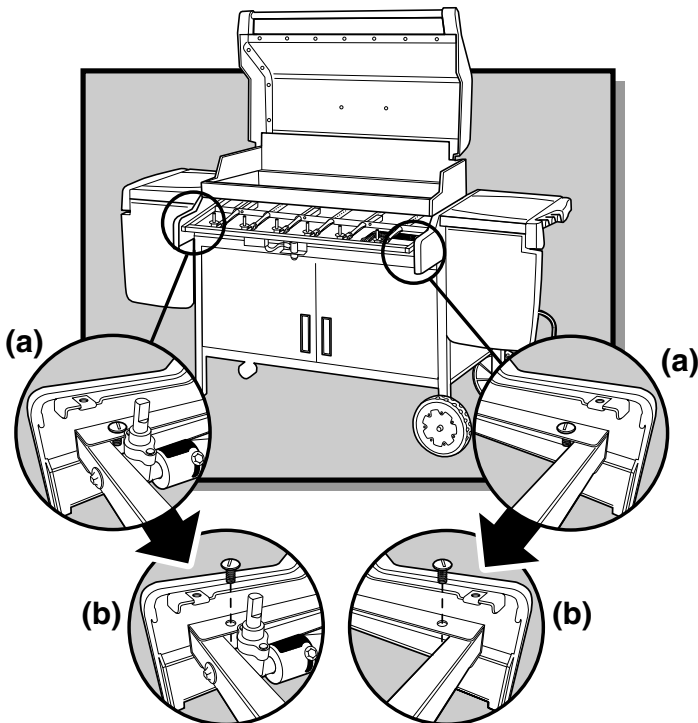

10. Pull manifold assembly out from the manifold frame.

SUMMIT® SILVER

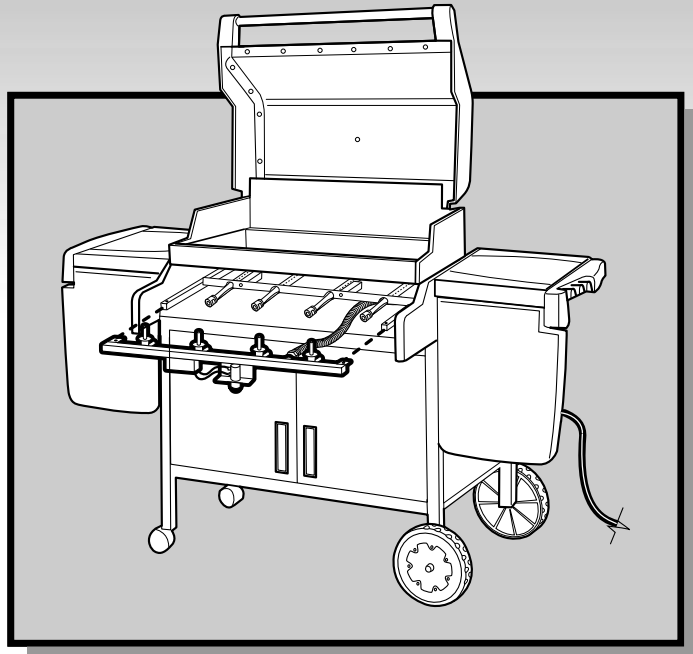

SUMMIT® GOLD

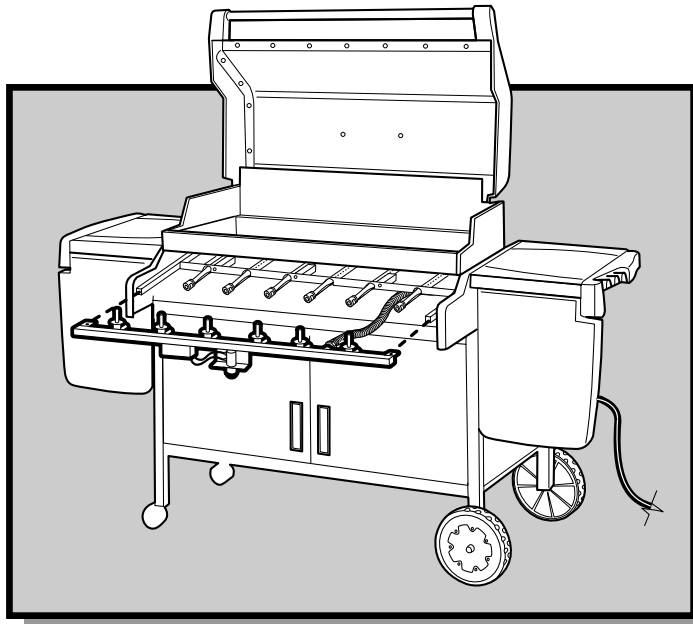

Maintenance

11. Lift and twist the burner assembly slightly, to separate the Crossover® tube (a) from the burners (b).

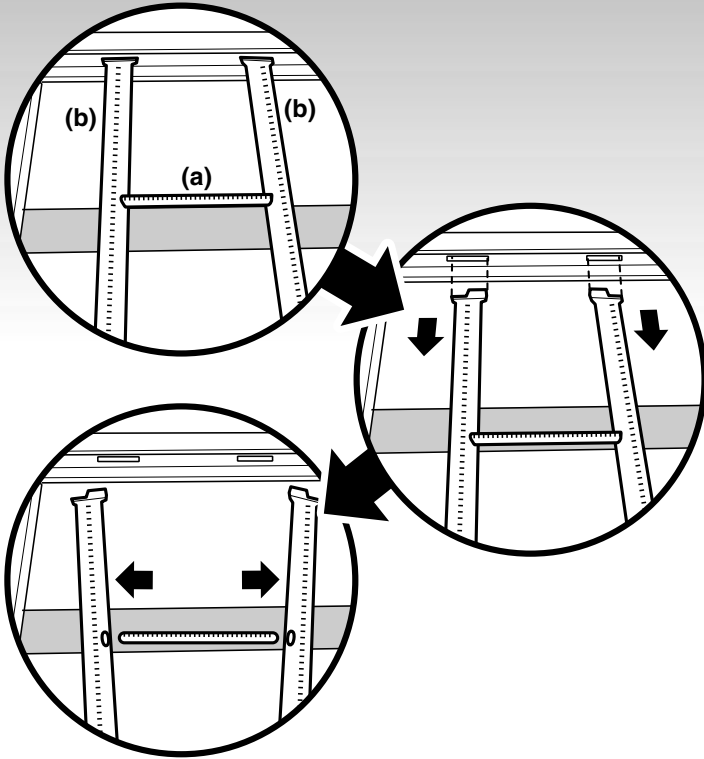

12. Remove the Crossover® tube.
13. Pull the selected burner(s) tube(s) from manifold frame and replace with a new burner tube.

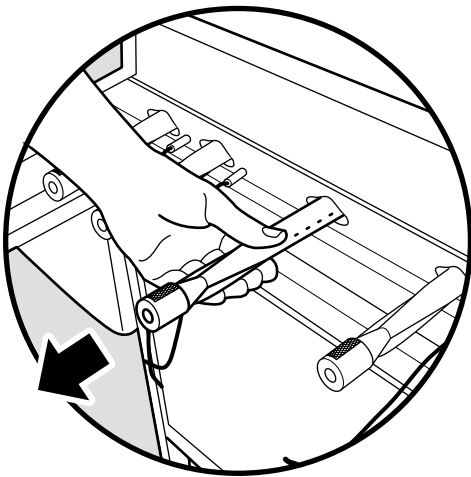

14. To reinstall the manifold assembly, reverse steps 7 through 13.

⚠CAUTION: The burner openings (1) must be positioned properly over the valve orifices (2).

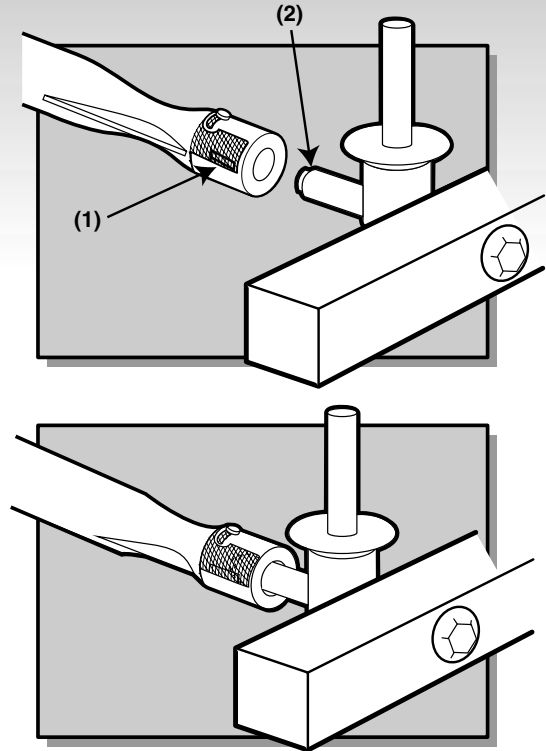

Check proper assembly before fastening manifold in place.

⚠WARNING: After reinstalling the gas lines, they should be leak checked with a soap and water solution before using the grill. (See, "Check for gas leaks.")

Crossover® Ignition System Operations

If the Crossover® ignition system fails to ignite the LEFT burner in a burner set, light the LEFT burner with a match. If the LEFT burner lights with a match, then check the Crossover® ignition system.

- Check that both ignition wires(1,2) are attached properly.
- Check that the Crossover® ignition button is activating.
- Replace battery with a like brand battery.
- You should hear the igniter sparking.

If the Crossover® ignition system still fails to light, contact the Customer Service Representative in your region using the contact information sheet provided with your manual.

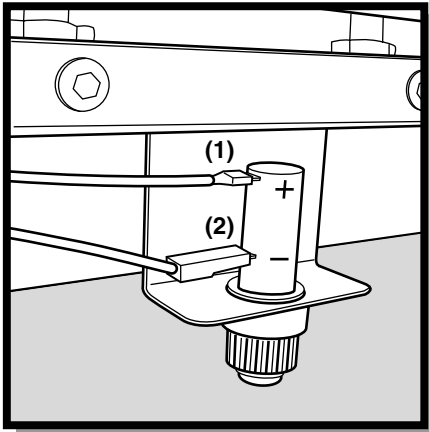

Replace Igniter Batteries

Parts required: 1 AA alkaline battery per igniter.

Unscrew igniter button from top of control panel. Remove igniter button and contact spring. Remove old battery and replace with a new AA alkaline battery. Positive end(1) of battery faces up as shown in illustration. Replace spring contact(2) and screw igniter button(3) back down.

