

This Owner's Manual is provided and hosted by [Appliance Factory Parts](#).

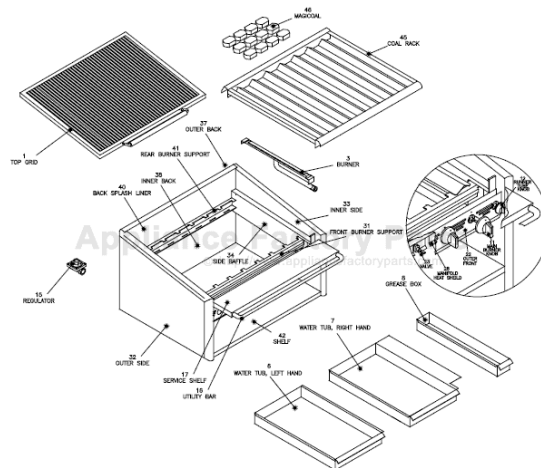

MagiKitchn FM-SMB 600 SERIES Owner's Manual

[Shop genuine replacement parts for MagiKitchn
FM-SMB 600 SERIES](#)



[Find Your MagiKitchn Grill Parts - Select From 352 Models](#)

----- Manual continues below -----

MAGIKITCH'N **MAGIKITCH'N** **MAGIKITCH'N**
MAGIKITCH'N **MAGIKITCH'N** **MAGIKITCH'N** **MAGIKITCH'N**
MAGIKITCH'N **MAGIKITCH'N** **MAGIKITCH'N**
MAGIKITCH'N **MAGIKITCH'N** **MAGIKITCH'N** **MAGIKITCH'N**

MAGIKITCH'N

**600 SERIES
GAS BROILER
INSTALLATION - OPERATION - MAINTENANCE**

MAGIKITCH'N
P.O. BOX 501
CONCORD NH 03302-0501
509 ROUTE 3A
BOW NH 03304
800-258-3708
603-225-6684
FAX 603-225-8497
www.pitco.com

NOTICE:

THE INSTRUCTIONS TO BE FOLLOWED IN THE EVENT THE ODOR OF GAS IS DETECTED ARE TO BE POSTED IN A PROMINENT LOCATION. THESE INSTRUCTIONS SHALL BE OBTAINED FROM THE LOCAL GAS SUPPLIER.

FOR YOUR SAFETY

**DO NOT STORE OR USE GASOLINE OR OTHER
FLAMMABLE VAPORS AND LIQUIDS IN THE VICINITY
OF THIS OR ANY OTHER APPLIANCE !**

**KEEP AREA AROUND APPLIANCES FREE AND CLEAR FROM
COMBUSTIBLES.**

FOR INSTALLATION IN NONCOMBUSTIBLE LOCATIONS ONLY

WARNING: Improper installation, adjustment, alteration, service or maintenance can cause property damage, injury or death. Read the installation, operating and maintenance instructions thoroughly before installing or servicing this equipment.

For installation or maintenance, contact your local dealer or authorized service agent. Installation or service by other than MagiKitch'n authorized service agencies or personnel may void warranty coverage. Call Pitco Frialator Technical Support at 800-258-3708 who will put you in touch with the proper local service organization or make service arrangements for you.

Table of Contents

- 1. Installation**
- 2. Gas Hook Up**
- 3. Gas Settings**
- 4. Lighting Instructions**
- 5. Initial Set Up**
- 6. Cleaning and Maintenance**
- 7. Important Instructions Recap**
- 8. Parts Illustration**
- 9. Parts List**
- 10. Warranty**

1. INSTALLATION

Units are to be installed in non-combustible locations only to utilize a 0" minimum clearance to non-combustible construction. Not approved for installations in combustible constructions. **This installation must conform to local codes.** In the absence of local codes, the installation must conform with the ***National Fuel Gas Code, ANSI Z223.1; Natural Gas Installation Code, CAN/CGA-B149.1;*** or ***Propane Installation Code, CAN/CGA-B149.2*** as applicable.

- The appliance and its individual shutoff valve must be disconnected from the gas supply piping system during any pressure testing of that system at test pressures in excess of ½ psi (3.45 kPa).
 - The appliance must be isolated from the gas supply piping system by closing its individual manual shutoff valve during any pressure testing of the gas supply piping system at test pressures equal to or less than ½ psi (3.45 kPa).
- A. Uncrate unit and put into place. The hitch pins securing burners must be removed. This will permit the burners to be readily removed for weekly inspection, cleaning and future service.
- B. FOR INSTALLATION ON LEGS: A set of 6" legs is packed in the top section of the broiler (unless unit is specifically ordered without). A threaded receptacle is located near each corner base of the machine. Each leg has a similar mating thread. Raise unit sufficiently to allow legs to be screwed tightly into receptacles. Level the unit by adjusting bottom feet of legs. Unit must be level to perform properly. FOR INSTALLATION WITH CASTERS: This installation shall be made with a connector that complies with the Standard for ***Connectors for Movable Gas Appliances, ANSI Z21.69,*** or ***Connectors for Moveable Gas Appliances, CAN/CGA-6.16,*** and with a quick-disconnect device that complies with the Standard for ***Quick-Disconnect Devices for Use With Gas Fuel, ANSI Z21.41,*** or ***Quick-Disconnect Devices for Use With Gas Fuel, CAN1-6.9.***
- Provide an adequate means of restraint without depending on the gas connector, the quick-disconnect device or its associated piping to limit the appliance movement.
 - The restraint (i.e. heavy gauge chain or cable) should be 1000# test load and should be attached to the building structure by some substantial means, such as the use of anchor bolts into concrete, or lag screws into studs in wooden structures. The opposite end of the restraint should be affixed solidly to the base of the unit at the back where it will not become pulled out or cause damage to the appliance.
- If disconnection of this restraint becomes necessary at any time, make sure it is reinstalled after the unit is placed in its original position and before the unit is placed in operation.

CAUTION !

Only two of the four casters supplied have brakes. Be sure to install the two casters with brakes *at the front of the unit.* NOTE: Front brakes should be locked before unit is placed in operation.

- C. COUNTER MODELS: All counter equipment is to be sealed to the counter to comply with applicable sanitation standards. A bead of silicone sealant, approximately ½" wide, is to be applied to the bottom of the unit approximately ¼" in from the front, back and side edges. We

suggest a Dow Corning®, GE® or Permatex® silicone 'RTV' adhesive sealant or equivalent. (See NSF **Basic Criteria C-2** for details).

2. GAS HOOK UP

An adequate gas supply is imperative. Undersized lines or low-pressures will restrict the volume of gas required for satisfactory performance. A steady supply pressure between 7" and 8" w.c. for natural gas and 11" to 12" w.c. for propane gas is required. With all gas appliances operating simultaneously, the manifold pressure on all gas appliances should not show any appreciable drop. Fluctuations of more than 25% on natural and 10% on propane gas will create pilot problems, and affect burner-operating characteristics. Contact your gas company for correct supply line sizes. After connection, all newly installed equipment should be checked for correct gas pressure by a certified gas serviceman. The unit should be connected **ONLY** to the type of gas for which it is equipped. Check the type of gas on serial plate.

- A. Attach regulator supplied with machine to inlet of the gas manifold. Be sure regulator is connected so that gas flow is in the direction of the arrow on the bottom of the regulator. Using a regulator other than the one supplied with the unit will void the warranty.
- B. The manifold pressure must be maintained at the pressure marked on the serial plate: 4" w.c. for natural gas and 10" w.c. for propane gas.
- C. Use pipe joint compound that is suitable for use with LP gas on all threaded connections.
- D. Turn off all burner valves.
- E. Turn on gas supply and check all connections for leaks using **ONLY** a leak checking fluid or soapy water. **NEVER** use an open flame to check for gas leaks.
- F. Provision must be made for adequate air supply for both appliance and occupants.
- G. Keep area in front of unit free from obstructions that could block flow of combustion and ventilation air.
- H. Be certain that adequate clearance is maintained so that air openings in front of unit are not blocked and any subsequent service can be performed. No such clearance is required on the sides. Sufficient clearance at rear is required for gas connections, regulator, and any master shutoff valve(s) installed. Be sure there is no obstruction in front.

3. GAS SETTINGS

Regulator pressure must be measured and adjusted before the unit goes into service, following installation and when operational performance is in question. A soft blue flame, just short of a yellow tip, gives the best results; combustion air can be adjusted by opening or closing the air shutter slightly.

4.LIGHTING INSTRUCTIONS

RMB 600 Series Models without safety pilot

- a.) Turn all burners to OFF.
- b.) Remove the top grid(s).
- c.) Remove the last radiant(s) closest to the side(s) of the unit.
- d.) Turn the runner tube valve to ON.
- e.) Light the runner tube.
Note: If the runner tube does not light, wait a few seconds, then try again.



- f.) Replace the radiant(s) and top grid(s).
Push and turn the burner valves to operate the individual burners as needed.
- g.) If any burner fails to light from the runner tube, shut off all the burners and the runner tube. Do not attempt to re-light for five minutes after shutdown. Repeat steps a thru f. If unit still fails to operate properly, contact authorized service personnel.

Broiler Shut Down

Turn all burners to OFF.
Turn the runner tube valve to OFF.

SMB 600 Series Models without safety pilot

- a.) Turn all burners to OFF.
- b.) Remove the top grid(s).
- d.) Turn the runner tube valve to ON.
- e.) Light the runner tube through the gap in the front of the coal support as shown.

Note: If the runner tube does not light, wait a few seconds, then try again.

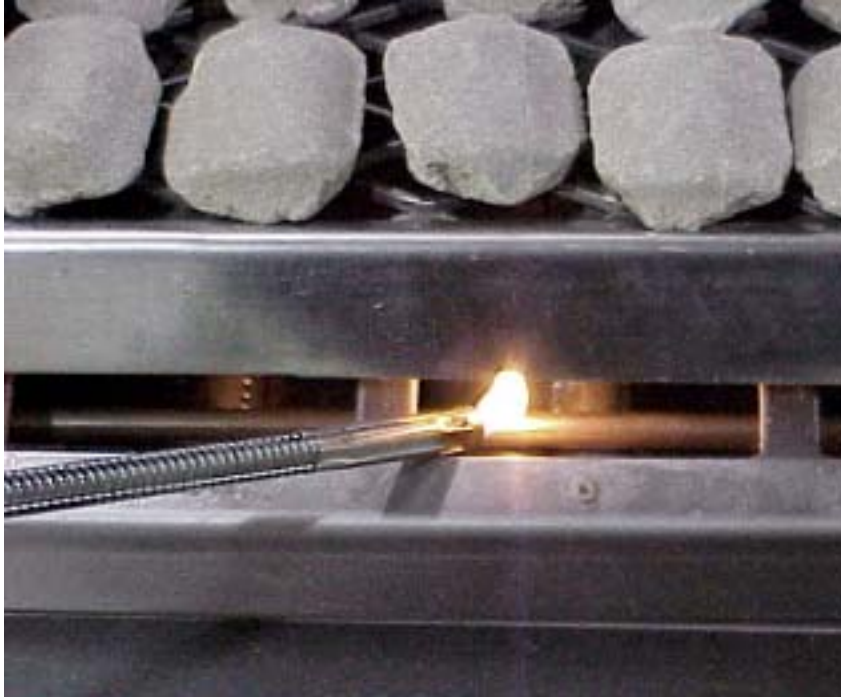

- f.) Replace the top grid(s).
Push and turn the burner valves to operate the individual burners as needed.
- g.) If any burner fails to light from the runner tube, shut off all the burners and the runner tube. Do not attempt to re-light for five minutes after shutdown. Repeat steps a thru f. If unit still fails to operate properly, contact authorized service personnel.

Broiler Shut Down

Turn all burners to OFF.

Turn the runner tube valve to OFF.

RMB 600 Series -S Models with safety pilot

1. Turn all burners to OFF.
2. Remove the top grid.
3. Remove a radiant.
4. Turn the shut off valve to ON.
5. Press and hold the reset (blue) button on the safety pilot valve. Wait 15–30 seconds. Light the runner tube. DO NOT release the reset button.

NOTE: If the runner tube does not light, wait a few seconds, then try again.

NOTE: When lighting the runner tube for the first time after connecting the unit to the gas source, the light time will probably increase to 1–2 minutes.

6. Wait an additional 15–30 seconds. Release the reset button. The runner tube should remain lit.

NOTE: If the runner tube fails to ignite, repeat step 5. If the runner tube fails to ignite after three attempts, contact an authorized MagiKitch'n service agent.

7. Replace the radiant and top grid.
8. Push and turn the burner valves to operate the individual burners as needed.

Broiler Shut Down

1. Turn the shut off valve to OFF.
2. Turn all burners to OFF.

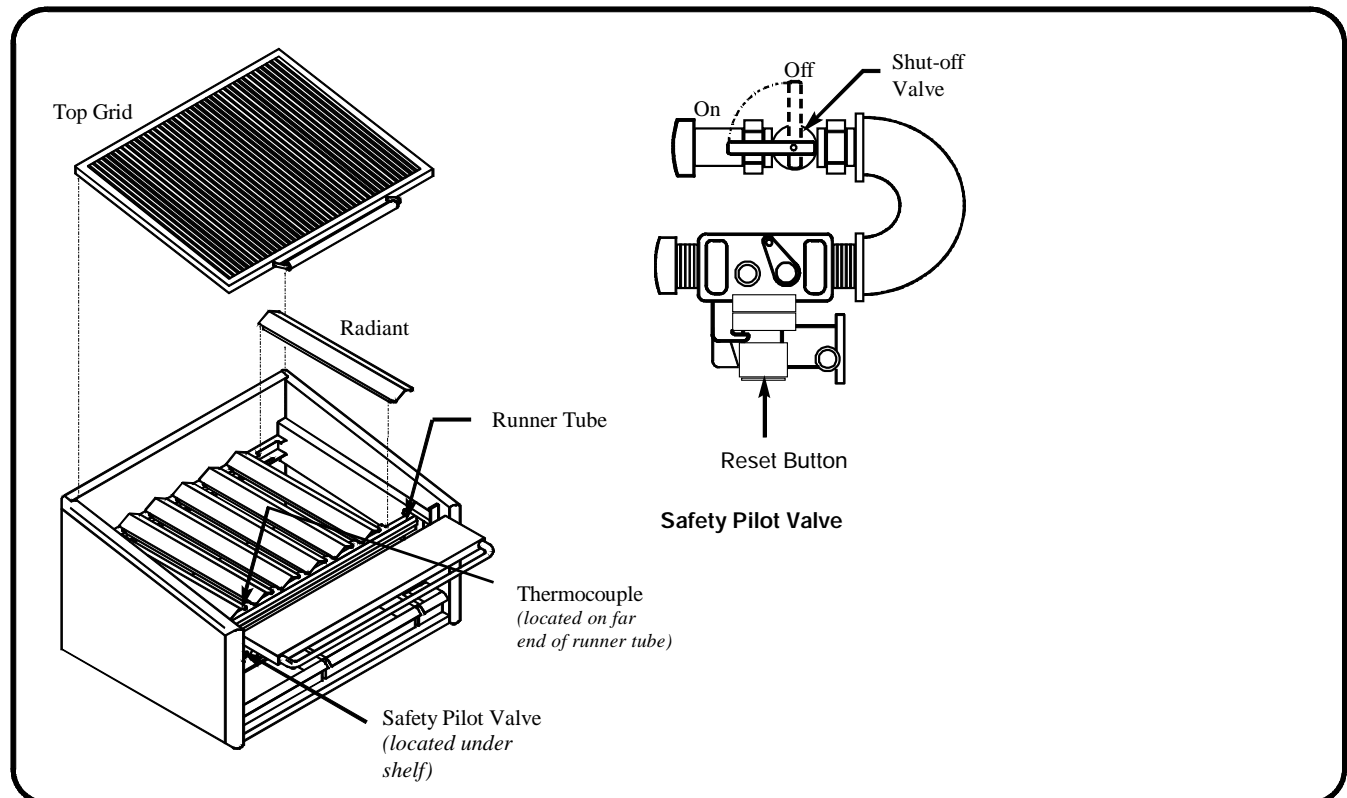

SMB 600 Series -S Models with safety pilot

Lighting and shut down of these models is identical to that of the RMB-S models except that there are no radiants to be removed. Simply light the runner tube by inserting the ignition device through the gap between the front burner support and the coal support as shown in the lighting instructions for the **SMB 600 Series Models without safety pilot**.

5. INITIAL SET-UP

All Models

PROPER SET UP OF THE BROILER - After the installation of the broiler by a qualified technician, a thorough cleaning is necessary. After this cleaning, be sure the broiler is set up properly.

TOP GRID - Your top cooking grid has two positions, either flat or tilted. Whenever you are broiling, you must use the tilted position. This allows grease to drain into the front trough, reducing both smoke and flare-up. Simply push down on the top grid handle and pull forward to set the tilted position. The flat position should be used only to heat soups and sauces, etc. in pots, and never to broil. For the flat position, just reverse the tilted grill procedure, by pushing down and back.

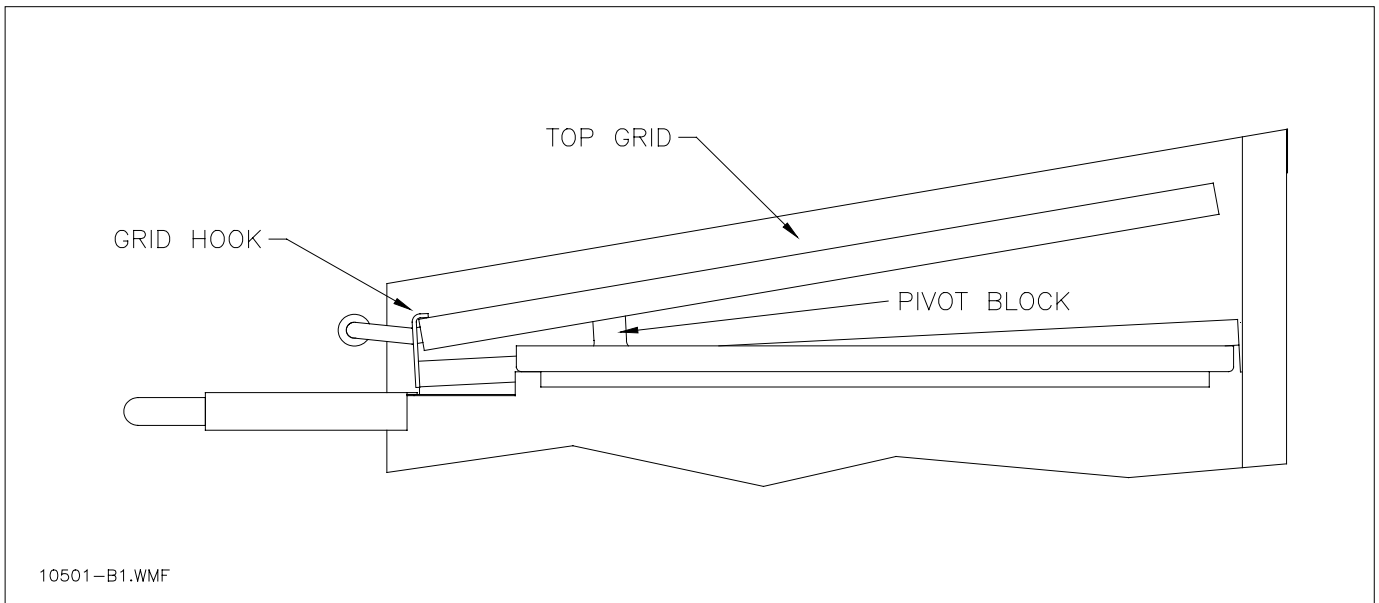

RMB 600 Series models

STAINLESS STEEL RADIANT - It is very important that the stainless steel radiants are placed over the burners. This will provide radiant heat and protect the burners from dripping grease.



PREHEATING - It is necessary to preheat a cold broiler each time before cooking. The recommended time is 3-5 minutes for radiant style charbroilers, at which time the cooking grid should be hot enough to cook on without sticking, and will produce the proper searing effect.

SMB 600 Series models

COAL SUPPORT - The coal support must be installed so that it is pushed against the back wall of the unit. This creates an air gap over the runner tube to allow proper ventilation.



COALS - Use only Magicoals supplied by MagiKitch'n. Do not use lava rock or other replacement coals. They do not perform as well or last as long as the Magicoals that were designed for this application. Place the coals evenly across the surface of the coal support. Do not pile them up. This will cause excessive flare up, reduce ventilation, and cause overheating of the valves and other components.



PREHEATING - It is necessary to preheat a cold broiler each time before cooking. The recommended time is 15-20 minutes for coal style charbroilers, at which time the cooking grid should be hot enough to cook on without sticking, and will produce the proper searing effect.

All Models

FLARE-UP - A certain amount of flare-up is desirable when you are charbroiling in order to flavor your products. However, excess flare-up will burn your products and leave a bitter taste. With flare-up, one simple formula holds true. The hotter the broiler and the higher the fat content of the food, the more flare-up you will have. Conversely, the lower the heat and lower the fat content, the less flare-up you will have.

FLARE-UP PROBABILITY CHART		
Heat Level	High Fat Content	Low Fat Content
High Heat	High	Moderate
Low Heat	Moderate	Low

6. CLEANING AND MAINTENANCE

DAILY CLEANING AND MAINTENANCE

TOP GRID - The top grid can be cleaned in numerous ways. The recommended procedure is to remove the grid and clean the frame, tubes and angles on front, sides and back with steel wool. The rods need only be scraped free of all cooking debris, especially the underside of the rods, using the MagiKitch'n scraper provided. The light oily sheen will aid in cooking, acting like a seasoned iron skillet.

OUTER SIDES AND FRONT - The outer sides and front are stainless steel. Any reputable cleaner can be used to clean these surfaces.

INNER COOKING AREA - These surfaces are also stainless steel. A paste type oven cleaner will work best to clean them, but be sure to *remove all residues* before you resume cooking operation. The grease collection pan should be emptied daily and the grease disposed of properly.

WATER TUB – The water tub is designed to reduce flair-up and to eliminate flash back, which is common on radiant style charbroilers. Flaming grease which drips down will extinguish as soon as it hits the water. The water tub should never be allowed to run dry and should be emptied daily and the grease disposed of properly.

Maintaining a clean, well-kept broiler will ensure long-lasting cooking performance and prolong it's life.

WEEKLY CLEANING MAINTENANCE

Generally, with this style broiler, you can follow the directions for daily cleaning. However, your top grid can be soaked in a detergent degreasing solution weekly or monthly. After this soaking, your grid will need to be thoroughly rinsed with fresh water and then re-seasoned.

7. IMPORTANT OPERATION INSTRUCTIONS RECAP

1. Always cook in a tilted position. This will allow excess grease to drain into the front grease trough and reduce smoke and flare-up.
2. Keep the top cooking grids clean, especially the underside of the rods. This will ensure that the grease will drain toward the front grease trough.

Remember the following formula for flare-up:
High Heat + High Fat Content = Maximum Flare-up
Low Heat + Low Fat Content = Minimum Flare-up

8. TYPICAL 600 SERIES ILLUSTRATION (Model RMB 636 shown)

Note: Your unit may vary from this typical diagram.

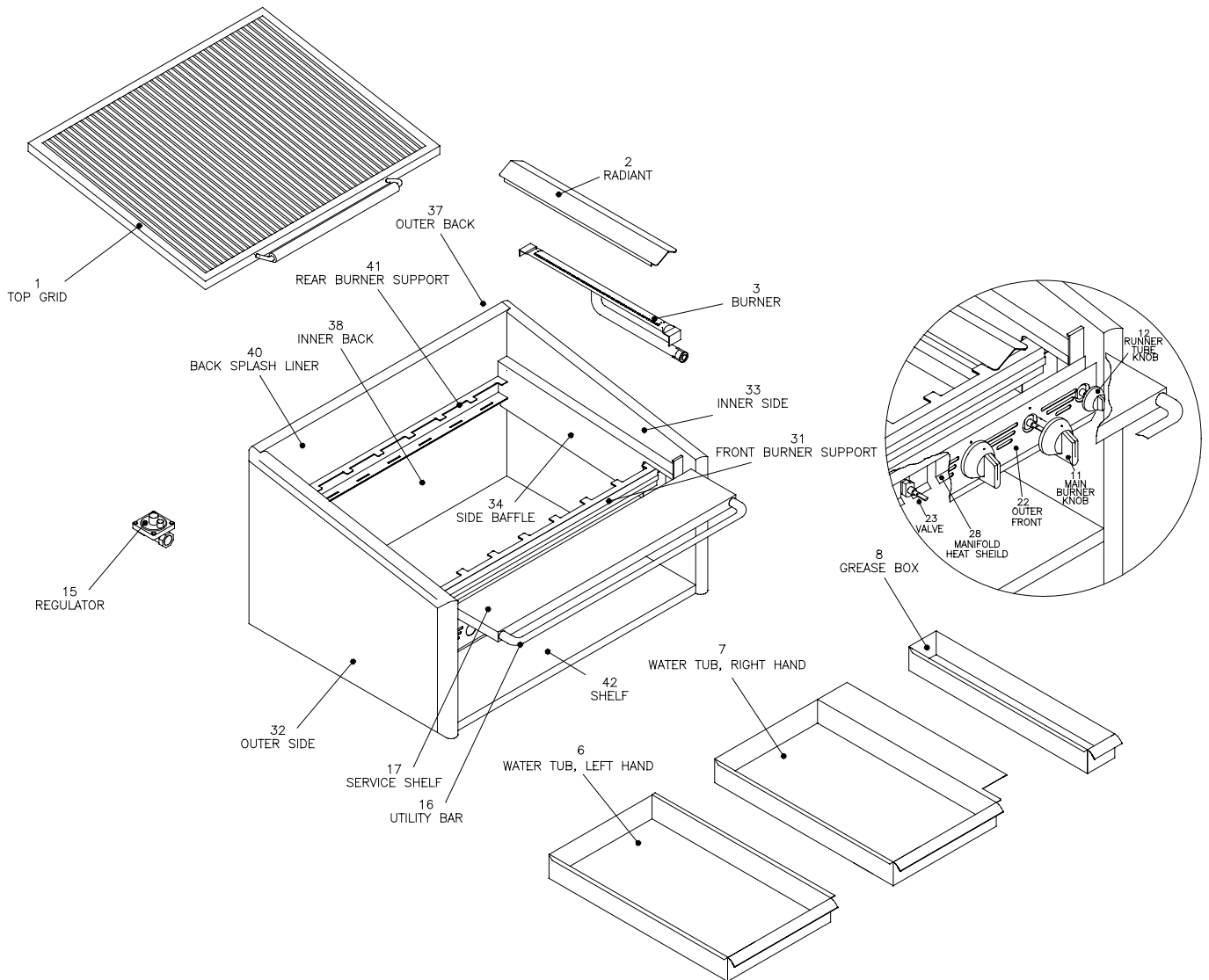

8. TYPICAL SMB 600 SERIES ILLUSTRATION (Model SMB 636 shown)

Note: Your unit may vary from this typical diagram.

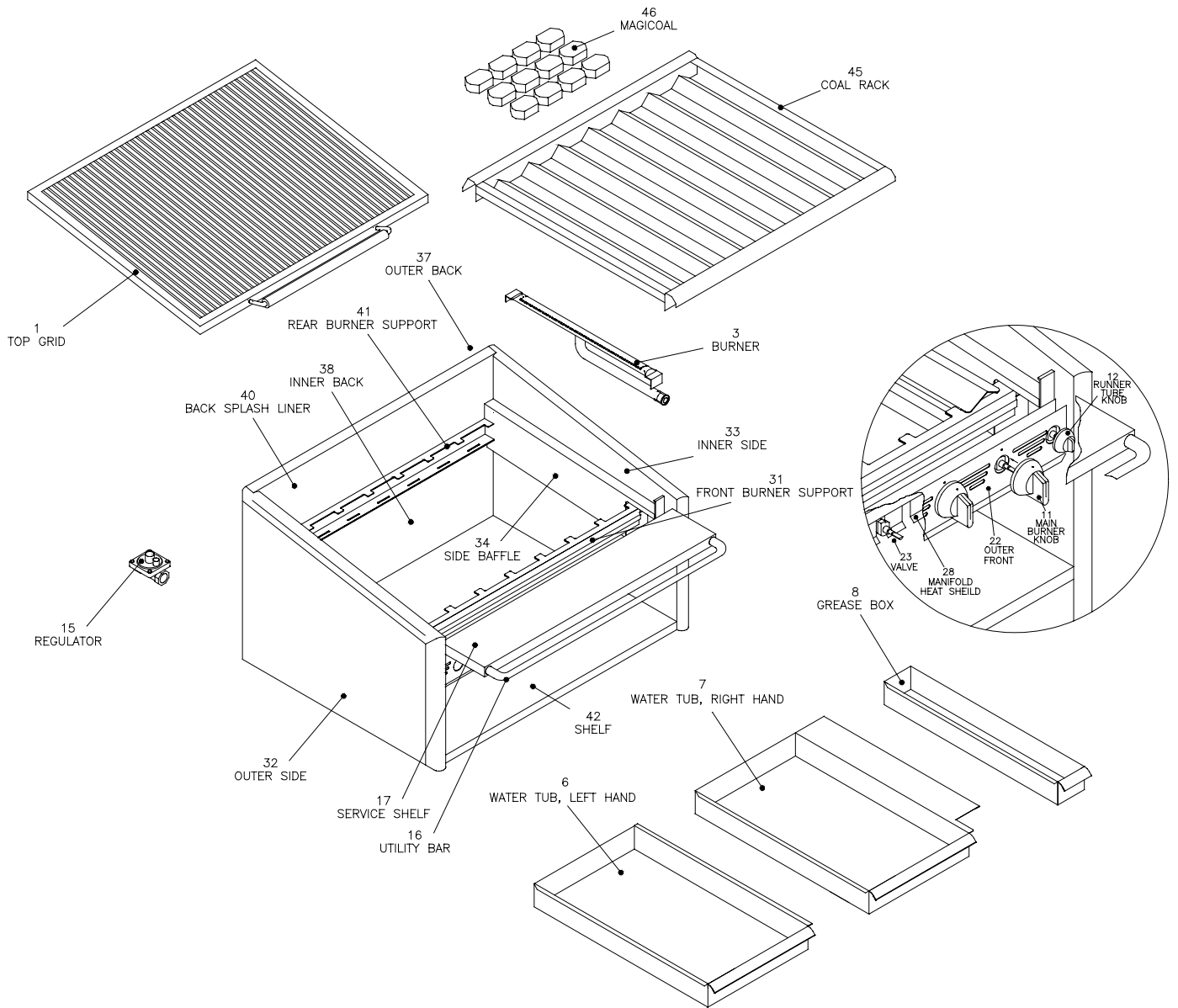

9. ACCESSORY / PARTS LIST FOR RMB/SMB 600 SERIES MODELS

Not all parts are illustrated, nor are all parts are listed. If you need a part that is not listed here, call MagiKitch'n for a quote. Always have your model and unit serial numbers available when phoning or ordering.

THESE PARTS SOLD THRU OUR DEALER NETWORK ONLY.

Ref. No.	Description
1	Top Grid, Standard
2	Radiant
3	Burner
4	Burner retaining clip (not shown)
5	Runner tube (not shown)
6	Water Tub, Left Hand
7	Water Tub, Right Hand
8	Grease Box
9	Leg, 6" (not shown)
10	Caster, 6" (not shown)
11	Knob, main burner
12	Knob, runner tube
13	Scraper (not shown)
14	Brush (not shown)
15	Regulator
16	Utility bar
17	Service shelf
18	Service shelf support (not shown)
19	LH Frame mtg brkt (not shown)
20	RH Frame mtg brkt (not shown)
21	Grease trough
22	Outer front

Ref. No.	Description
23	Gas valve, main burner
24	Gas valve,runner tube (not shown)
25	Orifice, main burners (not shown)
26	Orifice, runner tube (not shown)
27	Manifold assembly (not shown)
28	Manifold heat shield
29	Inner heat shield (not shown)
30	Inner front (not shown)
31	Front burner support
32	Outer side
33	Inner side
34	Side baffle
35	Side baffle support (not shown)
36	Top grid center support (not shown) (48/60/72 only)
37	Outer back (not shown)
38	Inner back
39	Back stiffener (not shown)
40	Back splash liner
41	Rear burner support
42	Shelf
43	Inner bottom (FM only, not shown)
44	Outer bottom (not shown)
45	Coal support (see SMB illustration)
46	Coals (see SMB illustration)

10. WARRANTY

ORIGINAL EQUIPMENT WARRANTY (For U.S. and Canada)

MagiKitch'n warrants to each original Buyer that its electrically-heated or gas-fired charbroilers / outdoor grills will be free from defects in material and workmanship for the period specified below. MagiKitch'n's obligation under this warranty shall be limited to replacing or repairing, at its option, any part found to be defective within the specified warranty period.

PRODUCT WARRANTY PERIOD

One (1) Year Limited Parts and Labor for Indoor Charbroilers 60 Day Limited Parts and Labor for Outdoor grills

The warranty period begins upon the earlier of the date of installation or 90 days after shipment of the covered product. Any labor expense or part failure incurred after the warranty period will be the responsibility of the end user. MagiKitch'n agrees to pay any authorized Blodgett service agency within the United States or Canada for any labor required to repair or replace, at MagiKitch'n's option, any part which proves to be defective due to defects in material or workmanship during the warranty period. This warranty includes travel time not to exceed two (2) hours and mileage not to exceed one hundred (100) miles, round trip.

This warranty does not cover any defect due to, or resulting from, ordinary wear and tear, handling, abuse, misuse, improper ventilation, or harsh chemical action, nor shall it extend to any unit from which the serial number has been removed or altered, or modifications made by unauthorized service personnel or damage by flood, fire or other acts of God. Adjustments such as calibrations, leveling, tightening of fasteners or plumbing connections normally associated with original installation are the responsibility of the dealer or installer and not that of the MagiKitch'n. Briquettes, bottom grates & burner covers are considered consumables and have a **warranty of 6 months only**.

MagiKitch'n shall not be liable, directly or indirectly, under any circumstances for consequential or incidental damages, including, but not limited to: (i) any loss of business or profits; and (ii) labor, material or other charges, claims losses or damages incurred or suffered from, in connection with or in consequence of the working upon, alteration, or repair of any such defective products or parts by persons or firms other than MagiKitch'n.

THIS WARRANTY AND THE OBLIGATIONS ASSUMED BY MAGIKITCH'N ARE EXCLUSIVE AND IN LIEU OF ALL OTHER LIABILITIES AND WARRANTIES, EXPRESS OR IMPLIED. MAGIKITCH'N MAKES NO REPRESENTATION OR WARRANTY OF ANY KIND, EXPRESS OR IMPLIED, AS TO MERCHANTABILITY, FITNESS FOR A PARTICULAR PURPOSE, OR ANY OTHER MATTER WITH RESPECT TO THE PRODUCTS SOLD HEREUNDER, WHETHER USED ALONE OR IN COMBINATION WITH OTHER EQUIPMENT. This warranty gives buyer specific legal rights, and buyer may have other rights which vary from state to state.

IMPORTANT NOTICE

The end-user purchasing a MagiKitch'n charbroiler or grill to which this warranty applies is urged to return the purchaser registration card included in the owner's document package. Upon the return of the registration card the warranty period will commence as provided above. If such registration

card is not returned, then the warranty period will be deemed to have commenced on the date of invoice for the particular oven to the dealer or other intermediate customer, which may have the effect of reducing substantially the duration of the warranty period.

MAGIKITCH'N

P.O. BOX 501
CONCORD NH 03302-0501
509 ROUTE 3A
BOW NH 03304
800-258-3708
603-225-6684
FAX 603-225-8497

KEEP THIS LITERATURE FOR YOUR RECORDS. WRITE YOUR MODEL AND SERIAL NUMBERS IN THE BOX ON THE FRONT COVER OF THIS MANUAL FOR FUTURE REFERENCE.

THIS WARRANTY CANNOT PROTECT YOU UNLESS YOUR MAGIKITCH'N APPLIANCE IS REGISTERED AT THE FACTORY. FOR YOUR OWN PROTECTION, MAIL ACCOMPANYING CARD WITHIN TEN DAYS AFTER THIS APPLIANCE HAS BEEN INSTALLED, OR WARRANTY WILL BE VOID

MAGIKITCH'N

P.O. BOX 501
CONCORD NH 03302-0501
509 ROUTE 3A
BOW NH 03304
800-258-3708
603-225-6684
FAX 603-225-8497
WWW.PITCO.COM