

This Owner's Manual is provided and hosted by [Appliance Factory Parts](http://ApplianceFactoryParts.com).

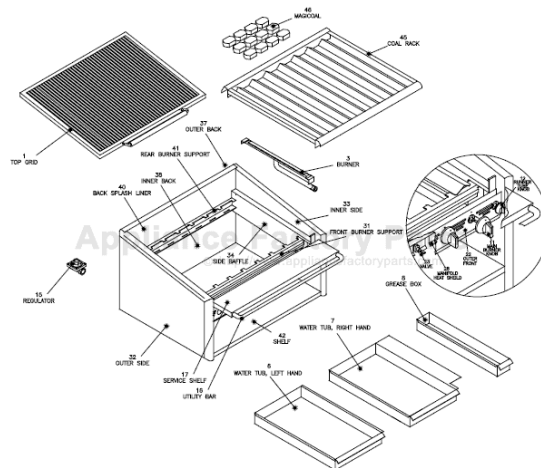

MagiKitchn FM-SMB 600 SERIES Owner's Manual

[Shop genuine replacement parts for MagiKitchn
FM-SMB 600 SERIES](#)



[Find Your MagiKitchn Grill Parts - Select From 352 Models](#)

----- Manual continues below -----

MagiKitch'n®

Model FM-RMB/SMB 600 Series Floor Radiant or Ceramic Coal Gas Charbroiler



Unit shown with optional lower rack

OPTIONS & ACCESSORIES (AT ADDITIONAL COST)

- Cooking Mode Conversion Kits
 - Ceramic Coal mode (from RMB to SMB)
 - SS Radiant mode (from SMB to RMB)
 - Cast Iron Radiants
- Round Rod Top Grid
 - Fish spacing
- MagiKrome Top Grids
 - Standard spacing Fish spacing
- Scround Rod Top Grids
 - Standard spacing Fish spacing
- 6" Cast Iron Top Grids (3 independent adjustable positions with reversible wide and thin marking)
 - Standard spacing Fish spacing
- Service Shelf with towel bar
 - Low profile 8" (20.3 cm)
 - 10" (25.4 cm) 12" (30.5 cm)
 - Supply shelf without towel bar
- Pan Cutouts in Service Shelf (specify with order)
- Divider for Pan cutouts
- Cutting Boards (10" or 12" shelves only)
- Fajita Rack Inserts
- MagiGriddle (Replaces top grid)
- Safety Pilot (supervised pilot system, see gas installation requirements)
- Quick Disconnect gas hose and lanyard kit
- Back Shelf
- Slip On Covers
- Side and Back Extensions (N/A with back shelf)
- 6" casters
- Lower Rack
- Smoker Box

Project _____

Item No. _____

Quantity _____

APPLICATION

The Model FM-RMB/SMB 600 Series is a high production floor charbroiler. Many options and accessories are available to tailor your charbroiler to match your menu selection and operational needs in the kitchen. This series is also available in a High Gas Output model for higher temperatures for heavy production restaurants.

MODELS

<input type="checkbox"/> FM-RMB-6xx-x (Radiant Model)	<input type="checkbox"/> FM-SMB-6xx-x (Ceramic Coal Model)
Model Size Width and Gas Btu Output Rate	
Standard Output**	(H) High Output
<input type="checkbox"/> 624 60Kbtu/hr	<input type="checkbox"/> 624-H 80Kbtu/hr
<input type="checkbox"/> 630 90Kbtu/hr	<input type="checkbox"/> 630-H 120Kbtu/hr
<input type="checkbox"/> 636 105Kbtu/hr	<input type="checkbox"/> 636-H 140Kbtu/hr
<input type="checkbox"/> 648 150Kbtu/hr	<input type="checkbox"/> 648-H 200Kbtu/hr
<input type="checkbox"/> 660 195Kbtu/hr	<input type="checkbox"/> 660-H 260Kbtu/hr
<input type="checkbox"/> 672 240Kbtu/hr	<input type="checkbox"/> 672-H 320Kbtu/hr

STANDARD FEATURES & ACCESSORIES

- **FM-RMB-600** - V-shaped radiant for each burner
- **FM-SMB-600** - Ceramic coal screen
- Free floating top grid ½" (1.3 cm) steel rods allows expansion and contraction without warping
- E-Z Tilt top grid drains grease into front trough
- Round top grid with standard spacing with quick lift handle
- Convertible Radiant design to Coal style
- Fully Insulated double walled outer cabinet
- Stainless steel on all four sides
- Water Tubs
- 6" (15.2 cm) stainless service shelf
- Towel bar for utensil storage
- Runner tube pilot system
- Individual front burner controls for precise regulation
- All stainless steel burners for long life
- Single ¾" gas connection
- Burners are 15Kbtu or optional High output 20Kbtu.
- 6" adjustable legs
- Top Grid Scraper

APPROVALS

- MEA Approved



**Standard Output Only

Model FM-RMB/SMB 600 Series Floor Gas Charbroiler

MagiKitch'n • P.O. Box 501, Concord, NH 03302-0501 • 509 Route 3A, Bow, NH 03304
603-225-6684 • FAX: 603-225-8497 • www.magikitch'n.com

L10-136 Rev 3 08/07 Printed in the USA



Model FM-RMB/SMB 600 Series Floor Gas Charbroiler

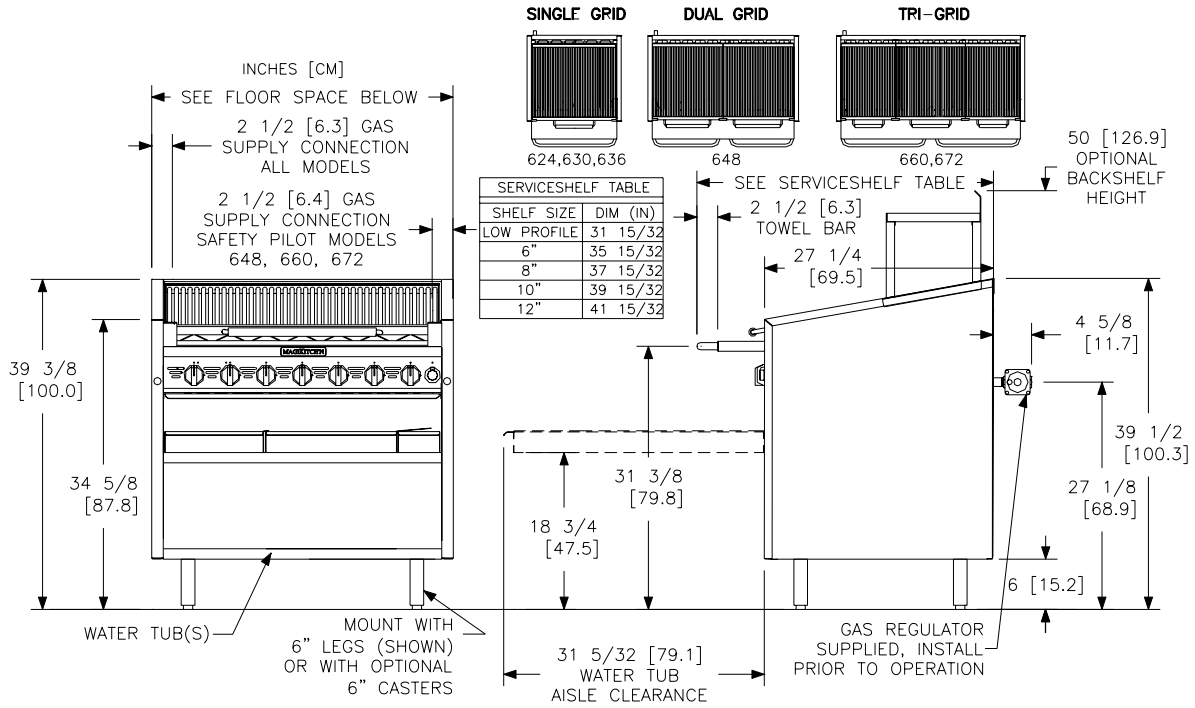

INDIVIDUAL CHARBROILER SPECIFICATIONS							
FM Size	624 / 624-H	630 / 630-H	636 / 636-H	648 / 648-H	660 / 660-H	672 / 672-H	
Gas BTU/HR	Standard Output	60,000Btu (17.6 kW)	90,000Btu (26.4 kW)	105,000Btu (30.8 kW)	150,000Btu (44.0 kW)	195,000Btu (57.2 kW)	240,000Btu (70 kW)
	(H) High Output	80,000Btu (23.4 kW)	120,000Btu (35.2 kW)	140,000Btu (41.0 kW)	200,000Btu (58.6 kW)	260,000Btu (76.2 kW)	320,000Btu (94.1kW)
Burners	4	6	7	10	13	16	
Cooking Area	513 in ² (3,314 cm ²)	662 in ² (4,271 cm ²)	810 in ² (5,233 cm ²)	1107 in ² (7,145 cm ²)	1404 in ² (9,063cm ²)	1704 in ² (11,001cm ²)	
Floor Space	24" x 35-1/2" (61 x 90 cm)	30" x 35-1/2" (76 x 90 cm)	36" x 35-1/2" (91 x 90 cm)	48 x 35-1/2" (122 x 90 cm)	60" x 35-1/2" (152 x 90 cm)	72" x 35-1/2" (183 x 90 cm)	
Crumb Trays	1	1	1	2	2	3	
Top Grids	Floating Steel	1 20 3/4 x 24 3/4" (52.7 x 62.9cm)	1 26 3/4 x 24 3/4" (67.9 x 62.9 cm)	1 32 3/4 x 24 3/4" (83.2 x 62.9 cm)	2 22 3/8 x 24 3/4" (56.8 x 62.9 cm)	1 20 3/4 x 24 3/4" (52.7 x 62.9 cm)	1 24 1/8 x 24 3/4" (61.3 x 62.9 cm)
	Cast Iron	3	4	5	7	9	11
Cast Iron grids are 6 1/4 x 22 5/8" (15.9 x 57.5cm), Reversible with Thick(1/4") and Thin(1/32") Marking. Cast Grids are available in Standard(13/16"), or Fish(11/16") spacing.							
SHIPPING INFORMATION (Approximate)							
Shipping Weight	220 lbs. (99.7 kg)	260 lbs. (118 kg)	295 lbs. (133 kg)	425 lbs. (192 kg)	565 lbs. (256 kg)	655 lbs. (297 kg)	
Shipping Crate H x W x L	56 x 35 x 47" (142 x89 x119 cm)	56 x 35 x 47" (142 x89 x119 cm)	56 x 35 x 47" (142 x89 x119 cm)	56 x 35 x 47" (142 x89 x119 cm)	56 x 35 x 47" (142 x89 x119 cm)	56 x 35 x 47" (142 x89 x119 cm)	
Shipping Cube	53.3 ft ³ (1.5m ³)	53.3 ft ³ (1.5m ³)	53.3 ft ³ (1.5m ³)	53.3 ft ³ (1.5m ³)	53.3 ft ³ (1.5m ³)	53.3 ft ³ (1.5m ³)	
INSTALLATION INFORMATION							
GAS PRESSURE REQUIREMENTS			GAS CONNECTION REQUIREMENTS				
	Natural Gas	LP Gas	Models without Safety Pilots		Models with Safety Pilots		
Supply Pressure*	7 - 10" W.C. (17.4 mbars/ 1.74 kPa)	11 - 13" W.C. (27.4 mbars/ 2.74 kPa)	(1) 3/4" Gas Regulator shipped unattached , (1) 3/4" NPT supply pipe connection		624, 630, 636 (1) 1/2" to 3/4" adaptor & (1) 3/4" Gas Regulator shipped unattached , (1) 1/2" NPT supply pipe		
Burner Pressure	4" W.C. (10 mbars / 1 kPa)	10" W.C. (25 mbars / 2.4 kPa)			648, 660, 672 (2) 1/2" to 3/4" adaptor & (2) 3/4" Gas Regulator shipped unattached , (2) 1/2" NPT supply pipe		
Gas Regulator MUST be installed to broiler gas supply prior to connecting gas line.							
* Check plumbing / gas codes for proper gas supply line sizing to sustain burner pressure when all gas appliances are full on.							
CLEARANCES (Can Not Be Flush Mounted)							
Front min	Floor min.	Combustible material		Non-Combustible material		Charbroiler Flue area	
30" (76.2 cm)	4" (10.2 cm)	Sides min.	Rear min.	Sides min.	Rear min.		
		6" (15.2 cm)	8" (20.3 cm)	0"	8" (20.3 cm)	Do not block / restrict flue gases from flowing into hood or install vent hood drains over the flue.	
SHORT FORM SPECIFICATION							
Provide MagiKitch'n model FM- RMB 6xx radiant or FM-SMB 6xx ceramic coal floor charbroiler. Unit shall be gas heated and shall cook by means of gas burners. Unit shall be double-walled stainless steel construction, and fully insulated on all sides. Provide with independent gas burners. Individual burner controls shall be mounted every 4 to 4-1/2 inches for flexible use. Convertible design allows operator to quickly change from radiant to coal style cooking with an optional conversion kit. Provide Options and Accessories as follows:							



MagiKitch'n • P.O. Box 501, Concord, NH 03302-0501 • 509 Route 3A, Bow, NH 03304

603-225-6684 • FAX: 603-225-8497 • www.magikitch'n.com L10-136 Rev 3 08/07 Printed in the USA

We reserve the right to change specifications without notice and without incurring any obligation for equipment previously or subsequently sold.