

This Owner's Manual is provided and hosted by [Appliance Factory Parts](#).



MagiKitchn LPAGA-30 Owner's Manual

[Shop genuine replacement parts for MagiKitchn
LPAGA-30](#)



[Find Your MagiKitchn Grill Parts - Select From 352 Models](#)

----- Manual continues below -----

COMMERCIAL COOKING APPLIANCES

Model LPAGA & LPCGA

Self-Contained Propane Fueled

Outdoor Charbroiler

Use and Care Instructions

Model # _____
Serial # _____
Date: _____

Retain this Manual for future reference



ANSI Z83.11a • CGA 1.8a-1997

MAGIKITCH'N

MAGIKITCH'N
P.O. BOX 501
CONCORD NH 03302-0501
509 ROUTE 3A
BOW NH 03304
800-258-3708
603-225-6684
FAX 603-225-8497
WWW.MAGIKITCHN.COM

TABLE OF CONTENTS

1. Safety Information	1
2. Charbroiler Assembly and Installation	4
3. Assembly Diagram	5
4. Mounting the Propane Tanks in the Tank Cart	6
5. Hanging the Tank Cart on the Charbroiler	6
6. Connecting the Gas Lines to the Propane Tanks	7
7. Operating, Lighting and Cleaning Instructions	8
8. Burner/Orifice Inspection	9
9. Charbroiler Illustration and Parts List	10
10. Tank Cart Illustration and Parts List	12
11. Options	13
12. Warranty	13

1. SAFETY INFORMATION

Safety instructions should be obtained from your local gas supplier and posted in a prominent location near the area of operation. These instructions are to be followed in the event of a gas leak.

FOR YOUR SAFETY

Do not store or use gasoline or other flammable vapors or liquids in the vicinity of this or any other appliance.

WARNING

Improper installation, adjustment, alteration, service or maintenance can cause property damage, injury or death. Read the installation, operating and maintenance instructions thoroughly before installing or servicing this equipment.

- This unit shall only be operated outdoors.
- This commercial appliance must only be operated by adults.
- The area of operation must be free and clear of all combustible material.
- Never obstruct the flow of combustion and ventilation air into or out of this unit.
- Always lock the caster brakes to prevent movement while the appliance is in use. On the side of the caster, press downward the 'ON' pad to apply the brake and on the 'OFF' pad to release it.
- Allow adequate clearance for air openings into the combustion chamber of this unit.
- Units may be operated with 0" minimum clearance to non-combustible construction in areas that are non-combustible locations. Unit is not approved for installations in combustible constructions.

1. SAFETY INFORMATION (continued)

- Unit intended for mobile, non-permanent installation only. Adequate clearances (minimum of 3') in front of the unit for servicing and proper operation must be maintained. Use only the legs and casters supplied with unit. Do not block the front or sides of unit.
- Check periodically to insure that the burners are fitted properly on the orifices (see burner/orifice inspection figure 9, Page 10), or when there is a performance problem.
- Inspect the flexible gas hose(s) prior to each use. If it is evident that there is excessive abrasion or wear, or the hose is cracked or damaged, it must be replaced before the appliance is put into operation. The replacement hose assembly shall be that specified by the manufacturer.
- **Fuel cylinders used with the tank cart** for this appliance must be constructed and marked in accordance with the specifications for propane cylinders of the U.S. Department of Transportation (DOT), or CAN/CSA B339. Such cylinders must be 40-pound horizontal system type, 12" in diameter and 29" in length, have a shutoff valve and a Type I, QCC1 service outlet connection. They must have a safety relief device that communicates directly with the vapor space of the cylinder. They must have a system arranged to withdraw vapor only in the horizontal position. The tank or cylinder must have a collar to protect the service valve from physical damage. **Do not use vertical tanks in this or any other horizontal tank system.**
- **Fuel cylinders used with the tank rack** for this appliance must be constructed and marked in accordance with the specifications for propane cylinders of the U.S. Department of Transportation (DOT), or CAN/CSA B339. Such cylinders must be 20-pound vertical type, 12" in diameter and 18" in length, have a shutoff valve and a Type I, QCC1 service outlet connection. They must have a safety relief device that communicates directly with the vapor space of the cylinder. They must have a system arranged to withdraw vapor only in the vertical position. The tank or cylinder must have a collar to protect the service valve from physical damage.
- This unit is for outdoor use only, in a well ventilated space! Do not operate this unit in a building, garage or any other enclosed area.
- Propane cylinders must be safely secured during transit and oriented in accordance with instructions and warnings marked on the cylinders.
- Do not allow cylinders to remain in areas of high heat, such as a closed car, trunk, or in direct sunlight. Consult instructions and warnings marked on the cylinders.
- When the unit is not in use, the gas must be shut off at the supply cylinder(s).
- Storage of the appliance indoors is only permissible if the propane cylinders are disconnected and removed from the appliance.
- Propane cylinders must be stored outdoors in a well ventilated area out of the reach of children. Disconnected cylinders must not be stored in a building, garage or any other enclosed area and must have protective dust caps installed over the outlet openings.
- The pressure regulator and gas hose assembly supplied with unit must be used. Use only replacement parts specified by the manufacturer.
- The handling, filling, use, storage and transportation of all sizes of LP gas cylinders must be in accordance with *NFPA 58, Storage and Handling of LP Gases*, or *CAN/CGA B149.2, Propane Gas Installation Code*.

1. SAFETY INFORMATION (continued)

- If your two-stage pressure regulator(s) are furnished with vent shields, they must be in place when the appliance is in use.
- The minimum ambient temperature for proper operation of this appliance is 50°F (10°C).
- Caution: The gas pressure regulator(s) provided with this appliance must be used. The appliance regulator is set for an outlet pressure of 10 inches water column.
- Do not locate this appliance under overhead unprotected combustible surfaces.
- Do not allow dirt or foreign material to get into the gas line connectors when they are not attached to the fuel supply system.
- If the burners or runner tubes fail to light or remain lit, discontinue use of the unit. Shut off the unit and the gas supply and disconnect it. Have the unit checked and serviced, if necessary, before use again.
- If you smell gas, discontinue use of the unit and shut off the gas supply. Have a qualified person determine if there is a gas leak and have it repaired before operating the unit again.
- Propane gas is highly flammable and heavier than air. Treat it with the caution and respect it deserves.
- Surfaces of unit will become hot during normal operation and can cause burns and/or serious injury . Do not touch a hot unit without protective clothing. Allow the unit to cool before cleaning or disassembling.
- Do not use in high wind conditions. High winds may adversely affect burner performance.
- Disconnect gas hoses and unhook the tank cart whenever moving the charbroiler. Careless handling, excess speed or rolling over anything other than smooth terrain could cause equipment damage and/or personal injury.

For installation or maintenance, contact your local dealer or the Authorized Service And Parts (ASAP) network at 1-800-298-1862. Installation or service by other than MagiKitch'n authorized service agencies or personnel may void warranty coverage. Consult the complete ASAP directory included with this manual or call MagiKitch'n Technical Service, at 1-800-258-3708 who will put you in touch with the proper local service organization or make service arrangements for you.

2. CHARBROILER ASSEMBLY and INSTALLATION

These unassembled parts should be included in your charbroiler package (Figure 1):

<u>Item Number</u>	<u>Description</u>
1	Cooking Grid (s)
2	Radiants
6	Frame Assembly
8	Runner Tube Cover(s)
9	Water Tub(s)
10	Base
25	Leg & Swivel Lock Caster Assemblies

Assembly Instructions for the Unit (refer to Figures 1 & 10, and Table 1)

1. Remove shipping bands from carton.
2. Remove top of carton.
3. Remove cooking grids(s), (1) from unit and set aside.
4. Remove and unwrap any small parts packages that are located inside beneath the cooking grid. **NOTE:** Parts made of stainless steel may be coated with a protective plastic film that must be removed before firing.
5. Lift frame assembly (6) from carton and set aside.
6. Lift water tub(s) (9) from carton and set aside.
7. Lift base (10) from carton and place upside down on ground.
8. To install the leg & caster assemblies, insert the assemblies (24) into the leg sockets on the base (10) and depress "snap button" on leg. The leg will slide into the socket and will lock into the correct location.
9. Flip the base over, with the leg & caster assemblies installed, into the upright position. The long hooks for the tank cart are on the front of the base, the short ones on the rear. Place the frame assembly (6) on base (10) with the shelf support brackets located in the notches on the front base assembly.
10. Place runner tube cover(s) (8) on their brackets to cover the runner tube(s).
11. Place the radiants (2) on their front and rear support pins over each burner.
12. Slide water tub(s) (9) into frame assembly (6).
13. Place cooking grid(s) (1) into frame assembly (6).

Assembly Instructions for the Tank Cart

1. Open the tank cart hardware package and remove the instruction sheet.
2. Thread the hex nuts onto the eyebolts as far as they will go. Place a flat washer on each one.
3. Install an eyebolt assembly into each of the four holes in the upper corners of tank cart.
4. Install another flat washer and an acorn nut over the end of each eyebolts. Align the eyebolts perpendicular to the cart sides (Figures 11 on page 12) and tighten them with wrenches.

3. ASSEMBLY DIAGRAM

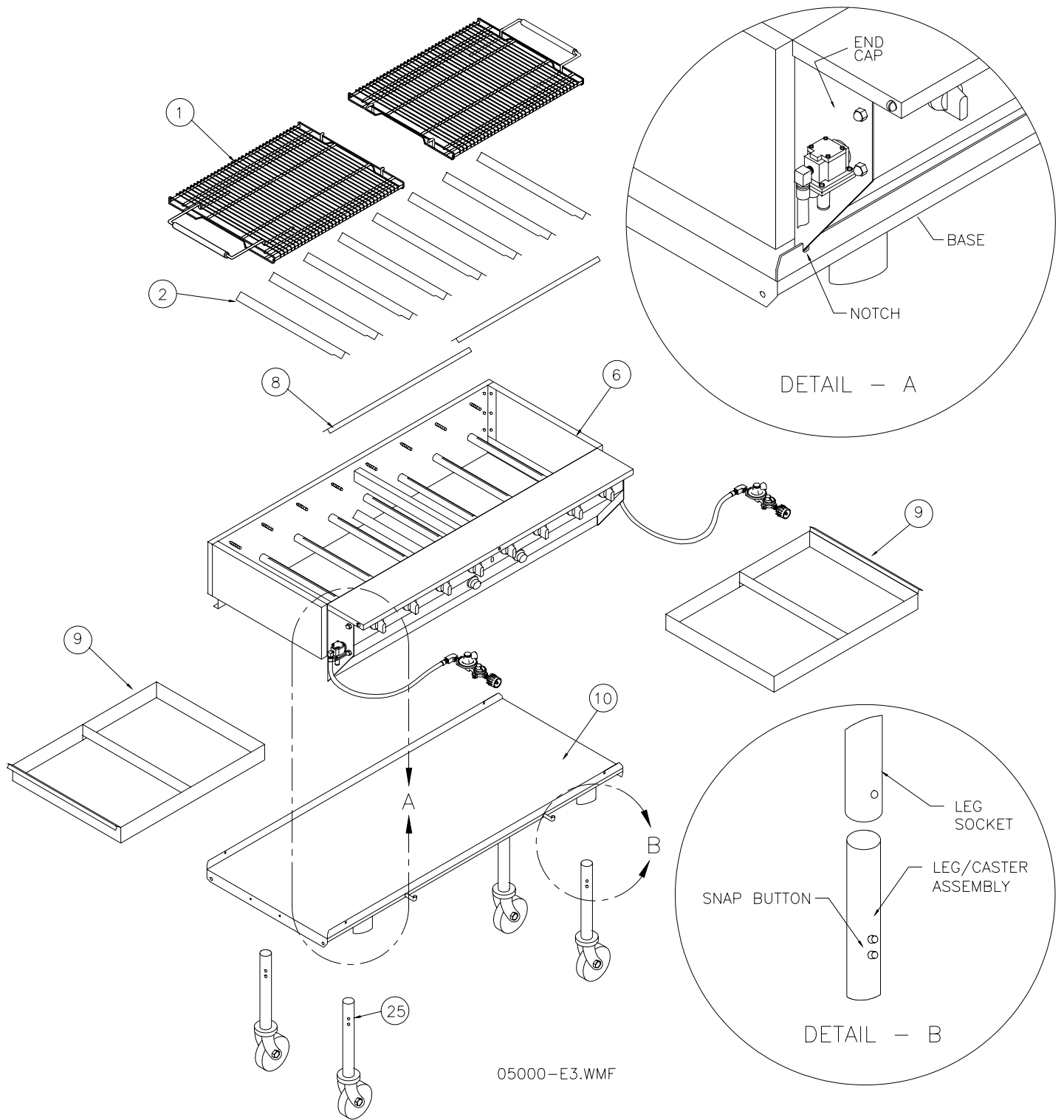

Figure 1

4. MOUNTING the PROPANE TANKS in the TANK CART

(Figures 2 and 3)

- A. Remove the front tank hold down bracket by unscrewing the wingnuts and lifting it from the studs.
- B. Place the tank on it's feet in the cart and slide the rear tank foot into the foot slot in the rear hold down bracket.
- C. Lower the front of the tank onto the floor of the cart so the front mounting foot rests over the tank stop.
- D. Replace the front hold down bracket so that the front tank foot fits under the slot in the hold down bracket.
- E. Re-install the wingnuts on the studs and tighten them in place. Check the tanks for secure attachment to the cart.

Caution: The tank cart will only accept 40-pound horizontal (all are clearly marked) DOT propane cylinders. Never use a vertical tank in this or any horizontal system.

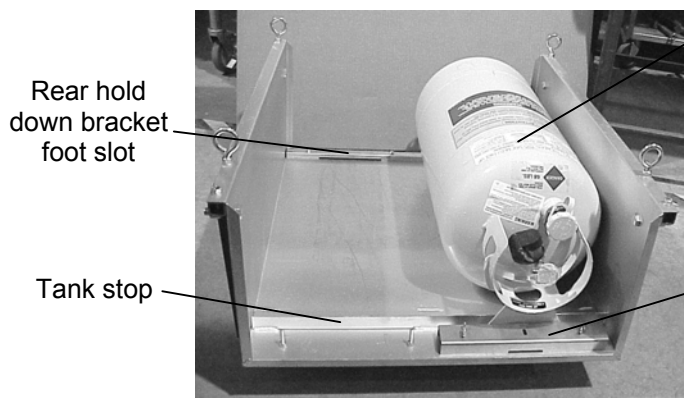

Figure 2

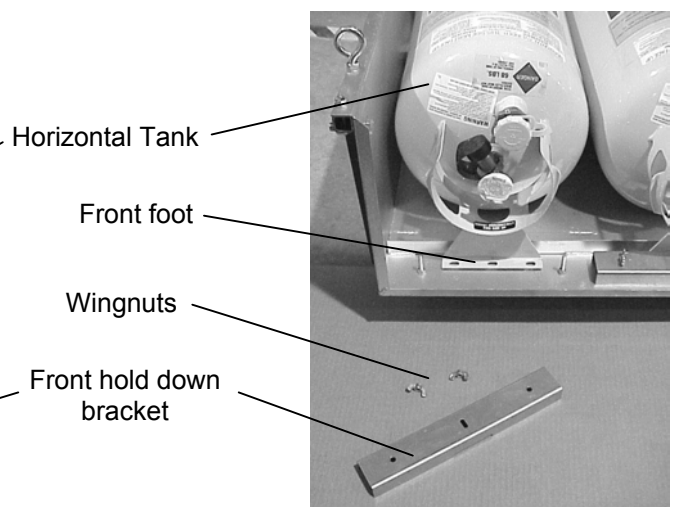

Figure 3

5. HANGING the TANK CART on the CHARBROILER BASE

(Figures 4 to 7)

- A. Lock all four casters on the base unit firmly so it doesn't move during this operation.
- B. Lift the fold-out handle at the front and raise the front of the tank cart so it will roll on it's back wheels. Back the cart under the front of the base unit, centering it between the caster legs.
- C. Line up the two front hanging rings on the cart with the two long hooks on the front of the base unit and hang the front rings of the cart onto the base hooks. Lower the front cart handle and fold it under.
- D. Go to the rear of the charbroiler and raise the rear fold-out handle of the tank cart. Lift the rear of the cart and slip the hanging rings onto the short hooks on the rear of the base unit. Lower the folding handle. Check that the tank cart is solidly attached to the charbroiler base unit.



Figure 4

Hanging the front of the cart first

Long hook on front base unit

Hanging ring on the front of tank cart

Front cart handle

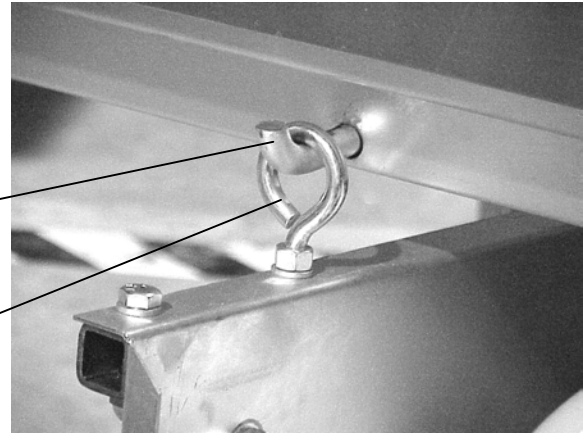

Figure 5



Figure 6

Hanging the rear of the cart

Short hook on rear base unit

Hanging ring on the rear of tank cart

Rear cart handle

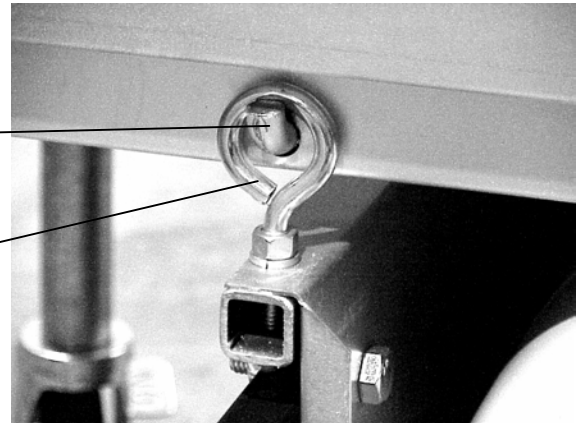

Figure 7

6. CONNECTING the GAS LINES to the PROPANE TANKS

- A. New propane tanks are shipped empty with no pressure and must be purged of air and filled with propane per NPGA (National Propane Gas Association) recommendations prior to initial use.
- B. Tank(s) must be mounted securely to the tank cart (See tank cart instructions).
- C. Tank cart must be hung beneath the charbroiler (See tank cart instructions).
- D. Install the black plastic gas connector(s) to the external thread on the tank valve(s). Turn each black knob clockwise and hand tighten.

Leak Testing

- E. The plumbing must now be tested for gas leaks before use. Turn all propane tank, burner control and runner tube control valve(s) to the "off" position. Wet all gas line fittings and connectors with a solution of soapy water (or commercial leak disclosing liquid). Slowly open the propane tank valve(s) and look for bubbles or foam at any of the joints in the system. If a leak is found, close the tank valves immediately and call your local dealer, the ASAP agency or the manufacturer.
- F. If the gas connections are leak-free, the unit is ready to use. Follow the lighting instructions in Sect. 7.

7. OPERATION, LIGHTING and CLEANING

- Assemble unit per installation/assembly instructions.
- Fill water tubs to within ½" of top edges (this will control grease flare-ups, provide for ease of cleaning and keep cooked foods moist). Re-fill tubs with water when they evaporate to within ½" of the bottom of the tubs. Failure to keep water in the water tubs will lead to grease fires and will void the warranty.

Lighting Instructions

- A. Check that the tank cart or side tank racks are securely mounted on the unit.
- B. Open the cooking hood, if so equipped. Turn all the burner knobs and red runner tube knobs clockwise to the 'off' position, and slowly open the gas tank valves.
- C. Push & turn the runner tube knob(s) fully counter-clockwise to the 'on' position. Insert a lit match with the matchstick holder or a gas lighter flame through the oblong hole in the front panel.
- D. Check that the entire runner tube is lit by looking through the sight hole(s) located between the end burner knobs on the front panel. If the runner tube(s) will not light or stay lit, shut off the gas supply and do not use the unit. Wait 5 minutes before attempting to re-light the unit.
- E. After lighting the runner tube(s), open the desired burner valves and observe that the burners light completely from the runner tubes(s).

Warning: If the burners or runner tube(s) fail to light or remain lit, shut off and disconnect the gas supply tank(s) and discontinue use of the unit. Call for service to correct the problem.

NOTE: If the tank valves are not opened very slowly, the excess flow valve in the tank connector fitting (a safety feature) may restrict the flow of gas to the unit resulting in little or no flame at the burners. Should this happen, follow the shutdown instructions and be sure to shut off tanks and remove and re-attach the tank connectors as instructed. This is necessary to re-set a closed excess flow valve. Repeat steps A through E of the lighting instructions. The appliance should now function normally. Failure to follow these guidelines may cause the excess flow valve to restrict gas flow.

Shutdown Instructions

- To shut down the unit, turn all burner and runner tube knobs clockwise to the 'off' position. Close gas tank valve(s), disconnect propane tank(s) and leave them outdoors.

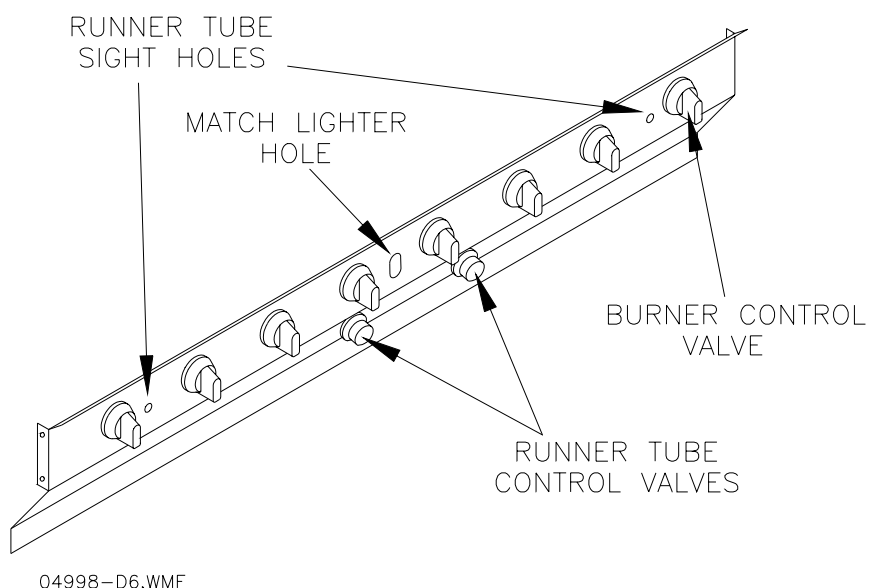

Figure 8

Cleaning the Unit

- Clean the unit regularly after use.
- Cooking Top Grid: After removing from the unit, use warm soapy water and a stiff bristled brush or plastic pad. Cooking grid (top grid) must be removed to steam clean or pressure wash. Do not use steel wool or abrasive pads as they may degrade the metal finish.
- Radiants/Covers: These will need little or no cleaning due to high in-use temperatures. If necessary, clean as for the cooking grid.
- Frame Assembly: Use warm, soapy water and a stiff bristle brush or plastic pad. Be careful not to get water into the burners or runner tubes. Do not pressure wash.
- Water Tubs/Base Assembly: Clean as per top grid.

8. BURNER/ORIFICE INSPECTION

- Remove the service shelf by removing the two screws at the ends (29).
- Slide service shelf forward and then lift it off the unit.
- The front of the burners, the valve bodies, and orifices are now exposed for inspection. Looking down into the unit, compare each assembly with the diagram below (Figure 9) for alignment.
- If the components **ARE NOT** aligned as shown in the diagram, **DISCONTINUE USE** and contact the appliance manufacturer.
- If they appear as in the diagram, carefully replace the service shelf and re-insert and tighten the screws. Your unit is ready for use.

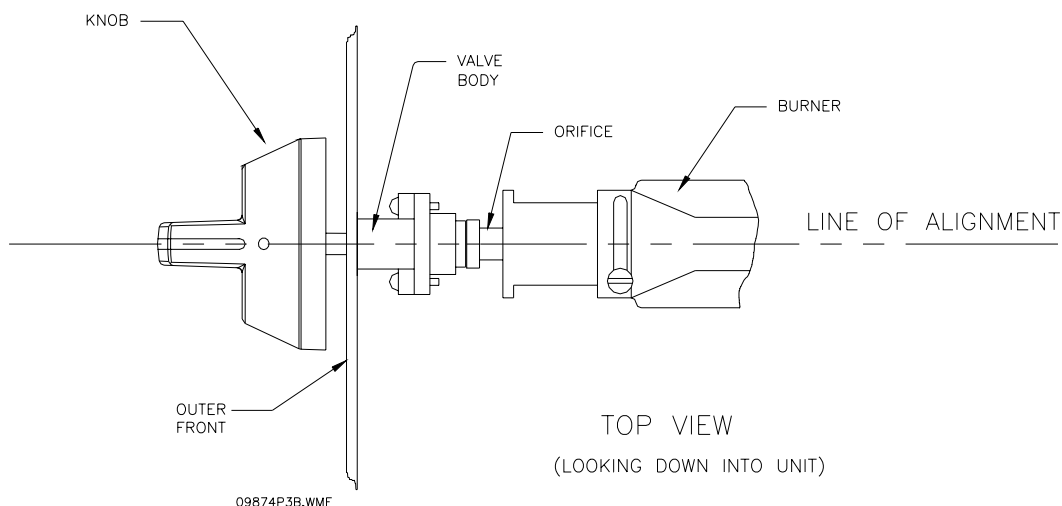
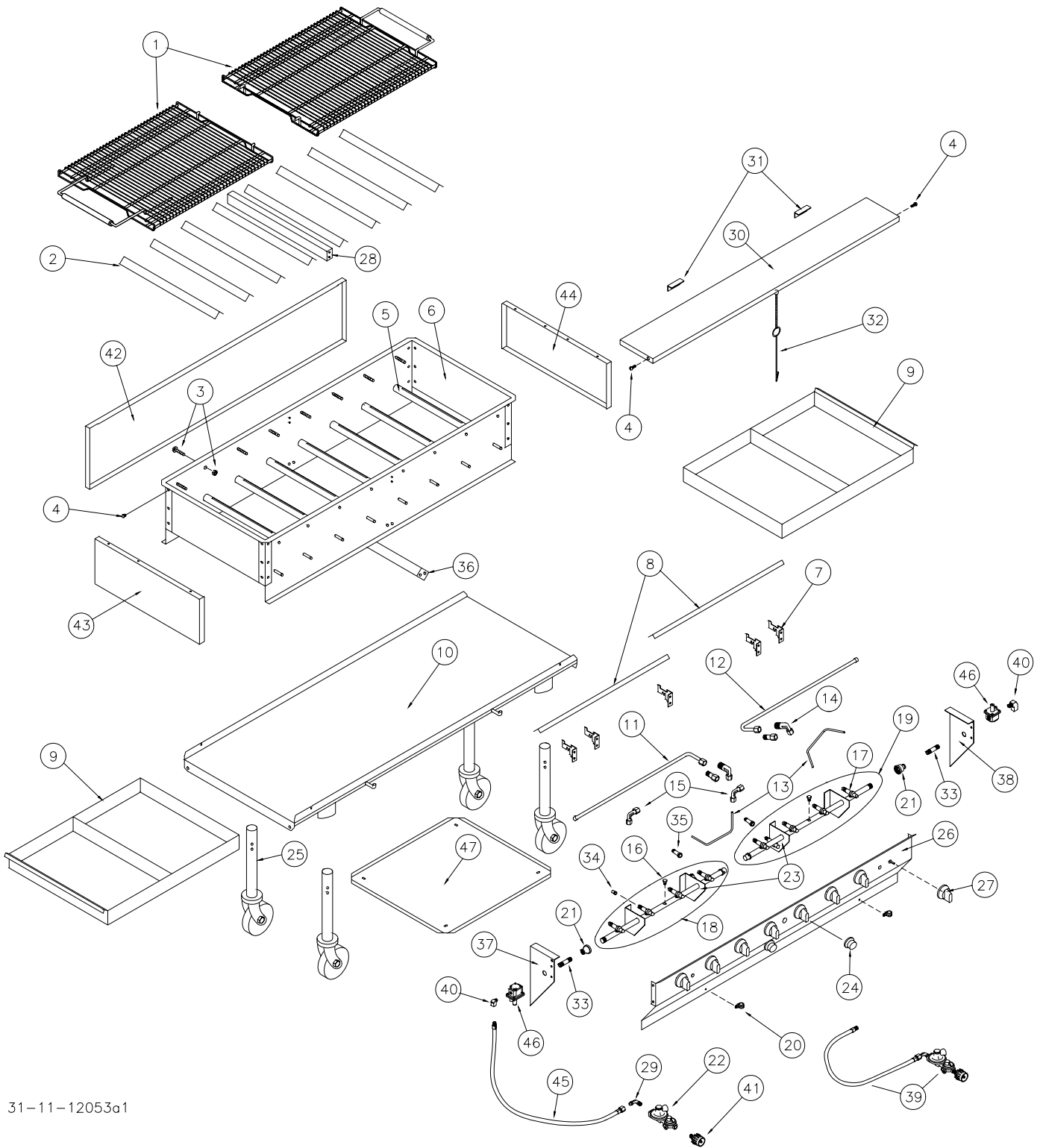

Figure 9

9. LPAGA CHARBROILER ILLUSTRATION



31-11-12053a1

Figure 10

LPAGA CHARBROILER PARTS LIST

Item #	Description	LPAGA / LPCGA-60		LPAGA / LPCGA-30	
		Qty	Part No.	Qty	Part No.
1	Cooking Top Grid, Heavy Duty	2	3912-0525300	1	3912-0525300
	Cooking Top Grid, Std (shown)	2	4100-0280400	1	4100-0280400
2	Radiant	8	5403-0500300	4	5403-0500300
3	Screw & Nut, 1/4-20 x 1-1/2"	16	4001-0485100/0485200	8	4001-0485100/0485200
4	Screw & Nut, 1/4-20 x 1/2"	52	4001-0049600/0485200	28	4001-0049600/0485200
5	Main Burner	8	3003-0486000	4	3003-0486000
6	Frame Assembly	1	5208-0983400	1	5208-0983100
7	Runner Tube Bracket	5	5403-0500200	3	5403-0500200
8	Runner Tube Cover	2	5199-0510400	1	5199-0510600
9	Water Tub	2	5417-0280000	1	5417-0280000
10	Base Assembly	1	53LS-1167700	1	53LS-1167400
11	Runner Tube, LH	1	3006-0419300	1	3006-0410100
12	Runner Tube, RH	1	3006-0419400	—	—
13	Runner Supply Tube	2	5608-0490100	1	5608-0490100
14	Fitting, 1/8 MPT X 3/16 C	2	2902-0871500	1	2903-0029800
15	Fitting, 90°, 1/8 FPT X 3/16 C	2	2908-0981300	1	2908-0981300
16	Plug, Pipe, 1/8 NPT	1	2909-0540200	1	2909-0540200
17	Valve, Main Burner Gas	8	2802-0877500	4	2802-0877500
18	Left Manifold Assembly	1	5201-0975300	1	5201-0975300
19	Right Manifold Assembly	1	5201-0975400	—	—
20	Clamp, hose mounting	2	3699-1165500	1	3699-1165500
21	Fitting, red. Coupling, 3/4 x 3/8 NPT	2	2909-1167800	1	2909-1167800
22	Regulator, two-stage, LP gas	2	2701-1133800	1	2701-1133800
23	Valve, Pilot Gas	2	2802-0983900	1	2802-0983900
24	Knob, Runner Tube Valve	2	3501-0983200	1	3501-0983200
25	Leg w/Swivel Locking Caster	4	5207-1175100	4	5207-1175100
26	Outer Front	1	5405-1169000	1	5405-1168900
27	Knob, Main Burner Valve	8	2802-1032300	4	2802-1032300
28	Center Support	1	53LS-0871600	—	—
29	Elbow, 90°, 3/8 MPT x 3/8 SAE	2	2904-1167000	1	2904-1167000
30	Service Shelf, Stainless Steel	1	5104-0974700	1	5104-0977000
31	Shelf Bracket, support angle	2	6003-0288800	—	—
32	Matchstick Holder	1	3699-1115100	1	3699-1115100
33	Nipple, pipe, 3/8 NPT x L, BMI	2	0801-1168000	1	0801-1167900
34	Orifice, #55, Short	8	2908-0977300	4	2908-0977300
35	Fitting, adapter, 1/8 ST X 1/8 NPT	2	2903-0980200	1	2903-0980200
36	Grease Baffle	1	53LS-0485600	—	—
37	End Cap, LH	1	5403-0994600	1	5403-0994600
38	End Cap, RH	1	5403-1169300	1	5403-0974600
39	Hose & 2-stage regulator ass'y	2	7201-1151600	1	7201-1151600
40	Elbow, 90° street, 3/8 NPT, brass	2	2904-1158700	1	2904-1158700
41	QCC1 tank connector	2	4102-0777000	1	4102-0777000
42	Trim, back	1	5405-0906800	1	5405-0917600
43	Trim, LH side	1	5405-0985700	1	5405-0985700
44	Trim, RH side	1	5405-0985600	1	5405-0985600
45	Hose ass'y only, LP gas, 37"	2	4103-1165300	1	4103-1165300
46	Regulator, Appliance, LP	2	2701-1133900	1	2701-1133900
47	Heat Shield, tank cart	1	5414-1153900	1	5414-1153900

Table 1

11. TANK CART ILLUSTRATION

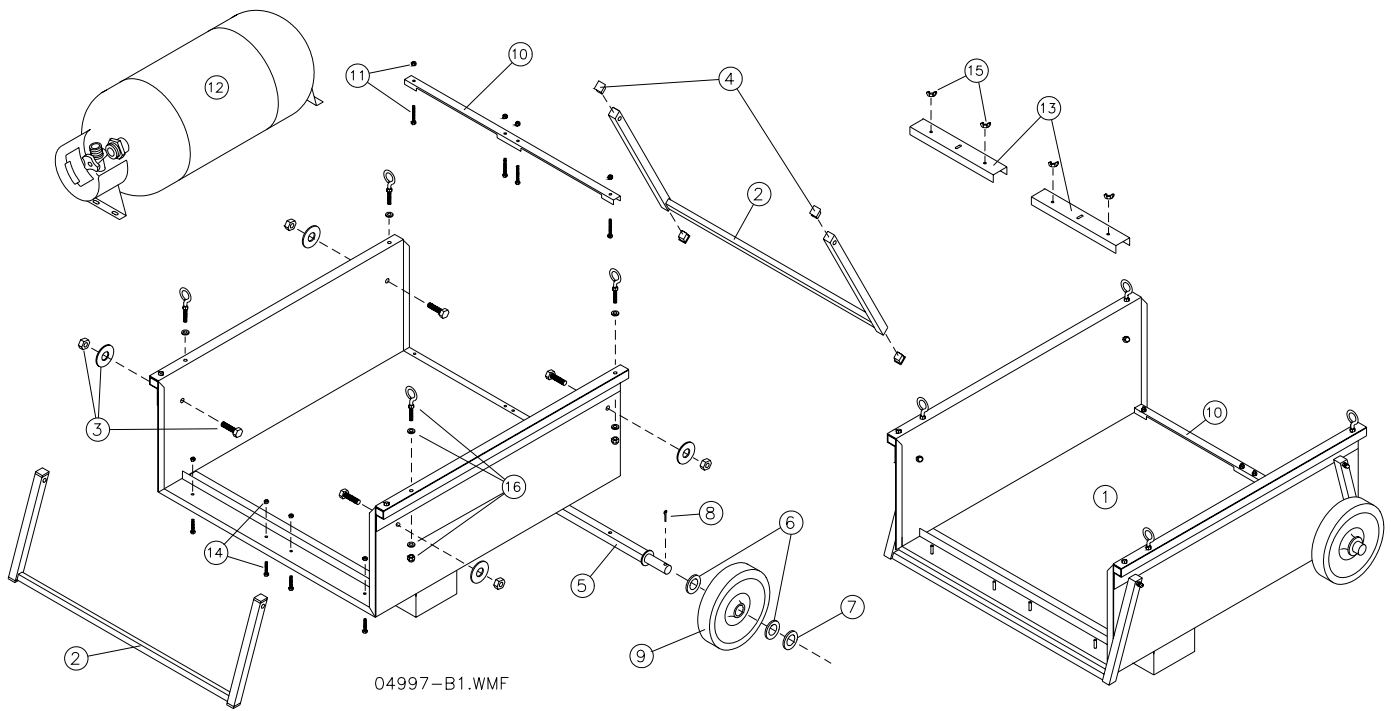

Figure 11

TANK CART PARTS LIST

Item #	Description	LPAGA / LPCGA-60		LPAGA / LPCGA-30	
		Qty	Part No.	Qty	Part No.
1	Cart Body	1	Not available	1	Not available
2	Handle, front and rear	2	53PB-0484000	2	53PB-0489600
3	Cap Screw, 1/2-13 x 2", Hex	4	4002-0263900	4	4002-0263900
	Flatwasher, 1/2", zinc	8	4004-0484900	8	4004-0484900
	Lock Nut, 1/2-13, Hex	4	4003-0295100	4	4003-0295100
4	Cap Plug, square tube	8	3502-0483900	8	3502-0483900
5	Axle	1	53PB-0483300	1	53PB-0489400
6	Flatwasher, 3/4", PVC	4	4004-0484100	4	4004-0484100
7	Flatwasher, 3/4", zinc	2	4004-0484300	2	4004-0484300
8	Cotter Pin, 3/32" x 1", steel	2	4004-0484400	2	4004-0484400
9	Wheel	2	2609-0485300	2	2609-0485300
10	Rear Hold Down	1	5414-0479500	1	5414-0489900
11	Cap Screw, 1/4 -20" x 2", Hex	4	4001-0485000	2	4001-0485000
	Hex Nut, 1/4 -20	8	4003-0485200	4	4003-0485200
12	Propane Tank, 40-lb., Horizontal	2	3905-1120700	1	3905-1120700
13	Front Hold Down	2	5414-1122600	1	5414-1122600
14	Cap Screw, 1/4 -20 x 1 1/2", Hex	4	4001-0485100	2	4001-0485100
	Hex Nut, 1/4 -20	4	4003-0485200	2	4003-0485200
15	Wingnut, 1/4 -20, elastic stop	4	4003-0295900	2	4003-0295900
16	Eyebolt Kit (not illustrated)	1	5299-0871800	1	5299-0871800

Table 2

12. OPTIONS

Some optional accessories for your MagiCater Gas Charbroiler include:

- MagiGriddle — Heavy polished steel griddle for cooking breakfasts, sautéing, etc.
- Steamer Set — Holds full-size hotel pans for steaming and warming.
- Cutting Board — Full length custom fitted Richlite cutting board fits over the service shelf.
- Split Hood — Twin roll-up hoods keeps heat in for roasting and broiling.
- Windguard — Keeps grill firing properly in windy conditions.
- Slip-on Stainless Steel Service Shelf — Adds another full-size worktop space at the back.
- Heavy Duty Top Grid — For serious cooking workloads.
- Waterproof Slipcover — Durable custom fit cover that protects against dirt and weather damage.

13. WARRANTY:

ORIGINAL EQUIPMENT WARRANTY (For U.S. and Canada)

MagiKitch'n warrants to each original Buyer that its electrically-heated or gas-fired charbroilers / outdoor grills will be free from defects in material and workmanship for the period specified below. MagiKitch'n's obligation under this warranty shall be limited to replacing or repairing, at its option, any part found to be defective within the specified warranty period.

We warranty this appliance against defective workmanship and material for 60 days from the date of shipment.

NOT WARRANTED:

Accident to, misuse of, harsh chemical cleaners, or natural wear of this appliance.

IMPORTANT:

Any defective parts must be returned for replacement under this warranty.

When writing, be sure to mention the serial number and model number appearing on the nameplate on the front of your equipment.

MAGIKITCH'N