

SERIAL #:

CENTRO

BBQ Stainless 8000

SAFE USE, CARE AND ASSEMBLY MANUAL

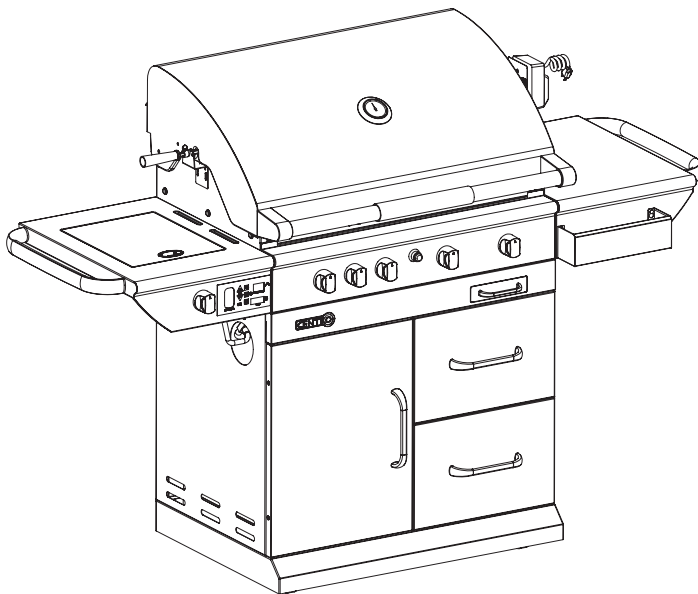

5 YEAR LIMITED WARRANTY

85-1087-6 (PROPANE) (G61003)

85-1088-4 (NATURAL GAS) (G61004)

Read and save this manual for future reference.

If pre-assembled, leave this manual with unit for consumer's future reference.

For product inquiries, parts, warranty and troubleshooting support, please call

1-877-707-5463

FOR YOUR SAFETY

If You Smell Gas

1. Immediately turn off the flow of gas to the unit.
2. Extinguish any open flame.
3. Open the lid of the unit.
4. If the odour does not stop quickly, immediately call your gas supplier or Fire Department for assistance.

FOR YOUR SAFETY

1. Do not store or use gasoline or other flammable vapours and liquids in the vicinity of this or other appliance.
2. An LP Gas cylinder not connected for use shall not be stored in the vicinity of this or other appliance.

WARNING

Failure to follow all of the manufacturer's instructions could result in hazardous fires, explosions, property damage, or serious personal injury or even death.

WARNING

Follow all leak check procedures carefully prior to operation of barbecue, even if barbecue was stored assembled. Do not try to light this barbecue without reading the Lighting Instructions section of this manual.

**THIS BARBECUE IS FOR
OUTDOOR USE ONLY**

TABLE OF CONTENTS

Warranty	ii
Installation Information	1
Additional Warnings	1
Use of LP Gas Cylinder,	1-2
Transportation and Storage of the LP Cylinder, Filling the LP Cylinder	
Prior to Using the Grill	3
Safety Hose and Regulator	4
Safety Leak Testing	5
Lighting the Main burners.	6-8
Sear Zone	9
Operating Instruction	
Rotisserie Burner	10
Operating Instructions	
Tips On Using	10
Your Rotisserie	
Moonlights	10
Information On	11
Natural Gas Model	
Parts List and	12-15
Parts Diagram	
Assembly Instructions	16-23



WARRANTY

5 Year Limited Warranty

This Centro BBQ carries a five year limited warranty against defects in manufacturing workmanship. This Limited Warranty is nontransferable and becomes void if used for commercial or rental purposes. This warranty applies only when grill is used in Canada. The bill of sale or a copy will be required together with the serial number and model number when making any warranty claims from Trileaf Distribution. Trileaf Distribution reserves the right to have its representatives inspect any product or part prior to honouring any warranty claim. Trileaf Distribution shall not be liable for any transportation charges, or labour cost. This warranty is for replacement of defective parts only. The Manufacturer will not be responsible for incidental or consequential damages or any labor cost. Inability to provide proof of purchase, or if warranty coverage has expired, any request for parts will be subject to parts, shipping and handling fees. This limited warranty does not cover damage due to chipping and scratching of porcelain or painted surfaces including Cooking grates, nor does it cover corrosion or discoloration due to misuse, lack of maintenance, grease fires, hostile environments, accidents, alterations, abuse or neglect, improper installation and failure to read and/or abide by any product warnings. This limited warranty does not cover any damage sustained during removal or storage of this BBQ. Part failure due to lack of cleaning and maintenance, or use of improper cleaning products such as Oven Cleaner will not be covered under this manufacturer's warranty. This limited warranty does not cover any scratches or dents, corrosion or discoloring caused by heat, abrasive or chemical cleaners. Parts installed from other manufacturers will nullify this warranty.

5 Year Limited Warranty

The following functional parts are included under this warranty: Burners, manifold assembly and carryover assembly.

3 Year Limited Warranty

The following functional parts are included under this warranty: Burners, manifold assembly and carryover assembly.

1 Year Limited Warranty

For one year from the date of original retail purchase Trileaf Distributions will replace any grill part that fails or is found to be defective to the degree of non-performance under normal household use, during the limited warranty period. Trileaf Distributions Ltd. are not responsible for any grill damage sustained during moving, storage, assembling or cleaning. Unless otherwise noted, as in above limitations, all components are covered for a period of one year.

IMPORTANT: Should you have difficulty operating this product, or have a part that has become defective within the stated warranty period, DO NOT RETURN TO STORE. STORES DO NOT STOCK replacement PARTS AND ARE UNABLE TO HELP WITH TROUBLESHOOTING ADVICE. PLEASE CALL 1-877-707-5463. Have your proof of purchase, serial number and model number available so that the customer support agent can be of assistance.

Purchaser: By accepting delivery of this Barbecue the purchaser, hereby accepts the foregoing and expressly waives any other remedy and damages, direct, indirect, and consequential.

INSTALLATION INFORMATION

The installation of this appliance must be in accordance with all local codes, or in the absence of local codes:

- Canadian installation must conform to the current national standards, which at this time are CAN/CGA-B149.1/2-Natural Gas/Propane installation code.
-

ADDITIONAL WARNINGS

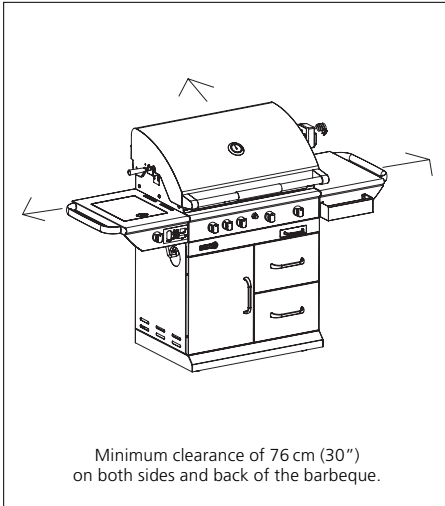

Drawing A

Minimum clearance to adjacent combustible materials:

- 76 cm (30") from furthest protruding edge on side of barbecue.
- 76 cm (30") from furthest protruding edge on back of barbecue.

See Drawing A

- Always keep the area around this barbecue clean and clear of any and all combustible materials such as gasoline or other inflammable liquids, paper or oily rags.
 - **Do not** operate this barbecue under any overhanging or unprotected construction.
 - Remember this barbecue is for **outdoor use only** and is **not** for use on any boat or recreational vehicle.
 - Use this barbecue outdoors in a well-ventilated area and at least 3 m (10') from any dwelling or other building.
 - **Do not** use in garages, or any other enclosed area.
 - **Do not** leave your barbecue unattended while in operation.
 - **Do not** obstruct the flow of combustion and ventilation air to the barbecue.
 - **Do not** use while under the influence of drugs or alcohol.
 - **Do not** store any spare L.P. (propane) cylinders, full or empty, under or near your barbecue.
 - **Do not** allow children or pets to play anywhere near the barbecue.
-

USE OF LP GAS CYLINDER

Self-contained Propane Gas System

The self-contained (propane) gas system barbecue is designed to be used with only a 9.1 kg (20 lb) propane cylinder equipped with a type-1 cylinder valve. This barbecue **cannot** be connected to an existing #510 P.O.L. type valve cylinder (which has left-handed threads).

Do not connect to a propane gas cylinder exceeding 9.1kg capacity or use a cylinder with any other type of cylinder valve connection device.

The Type-1 valve can easily be recognized by the large external thread on the outside of the valve. Older existing valves **do not** have this outer external thread. Any attempt to connect a regulator to any connector other than the mating Type-1 connector (which comes with a large, black coupling nut such as the #510 P.O.L.) could result in fires, injuries or property damage, and could reduce the effectiveness of the important safety features built into the Type-1 system. Also connecting the #510 P.O.L. fitting to the cylinder will negate the flow control and the temperature shut-off features built into the new Type-1 connection system.

- The cylinder should not exceed 472 mm (18 1/2") in height and 317 mm (12 1/2") in diameter.

When purchasing a cylinder for your barbecue, it must be constructed and marked as meeting the specifications of:

- Canada: Transport Canada.

The Cylinder must also be equipped with:

- A shut-off valve with a correct cylinder valve outlet as specified in current standards.
 - Canada: CAN/CGA 1.6g-M97 Outdoor Gas Grilles.
 - a) A safety relief valve with direct connection to the vapour space of the cylinder.
 - b) A collar to protect the tank shut-off valve.
 - c) A device for vapour withdrawal.
 - d) A ring on the bottom to secure the tank to its support assembly.
- Always turn off the cylinder valve completely when the barbecue is not in use.
 - Always handle the tank valve with utmost care.
 - Never connect an unregulated L.P. gas cylinder to the barbecue.
 - Always keep the cylinder, in use, securely fastened in an upright position.
 - Never store a spare cylinder, empty or full, near or under the barbecue when in operation.
 - Never expose the cylinders to direct sunlight or excessive heat.
 - Never insert any kind of object into the valve outlet as this may damage the backcheck; a backcheck that is damaged can leak, and a leaking propane cylinder can result in fires or explosions, property damage, severe injuries or death.

**TRANSPORTATION
AND STORAGE
OF THE LP CYLINDER**

The propane cylinder is totally safe when handled properly, but if misused, the result could be an explosion or fire resulting in serious personal injury and/or property damage.

To Avoid Unnecessary Risks

- Always recap the cylinder with the cap provided when not connected to the barbecue.
- **Do not** store the cylinder in any enclosed area such as a garage, and make sure the storage area has lots of ventilation.
- **Do not** store the cylinder near any appliances, or in any areas that may become hot, such as the trunk of a vehicle.
- Make sure the cylinder is out of reach of children.
- When transporting or storing the cylinder, make sure it is in an upright position and not on its side.
- **Do not** smoke around the cylinder, especially when transporting it in a vehicle.

**FILLING THE
LP CYLINDER**

The cylinder must be filled prior to use and must have the air purged. For safety, follow these instructions when having your cylinder filled:

- Have only your local qualified LP gas dealer fill or repair a cylinder.
- **Do not** overfill the cylinder beyond the safe 80% fill level.
- Make sure the dealer tests and checks the cylinder for leaks after filling.

WARNING

**If the above instructions are not completely adhered to,
it could cause a fire/explosion, resulting in death or serious injury,
or property damage.**

PRIOR TO USING

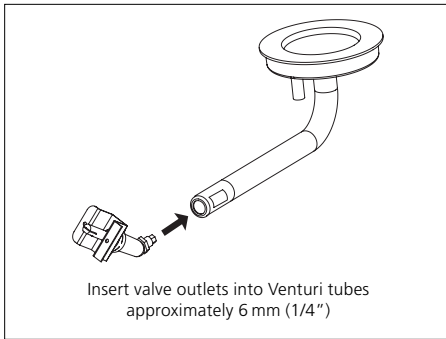

Drawing E

Do not use your barbecue until you have carefully read and fully understand all the information in this manual. Please ensure the following:

- Your barbecue is properly assembled.
- There are no leaks in the system (see "Leak Test").
- The burner is properly assembled, with the Venturi tubes seated over the valve outlets (Drawing E) and that there is nothing blocking the Venturi tubes (Drawing F).
- Ensure that all power cords and/or gas supply hoses will not touch or be near surfaces that will get hot.
- The barbecue is in a safe location (see Installation).

Ensure that the valve outlets (orifices) are assembled into the Venturi tubes approximately 6 mm (1/4") and that the valve outlets and Venturi tubes are approximately parallel to the bottom of the lower body.

WARNING

Natural Hazards Insects and Spiders

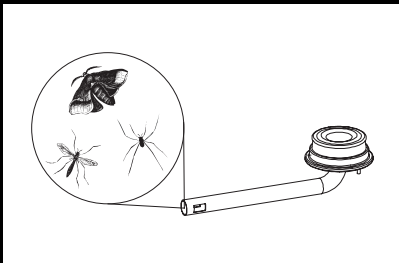

Drawing F

During shipment or storage, it's possible that small insects like spiders could find their way into the Venturi tubes and nest or make webs. This could block the flow of gas through the Venturi tube causing a smoky yellowish flame, or prevent a burner from lighting. It could even cause the gas to burn outside the Venturi tube, which could seriously damage your barbecue. If these occur, turn off the gas flow and wait for the barbecue to cool down. When the barbecue has cooled, remove the burner and clean out the Venturi tubes with a brush or pipe cleaner. Replace the burner and ensure that the Venturi tubes are seated over the orifice located on the gas valves. Cleaning the Venturi tubes should be conducted periodically, especially at the start of the season.

Note: Damage resulting from blocked Venturi tubes is not covered under the warranty.

Orifice Size: The orifice, in conjunction with the control valve, acts to regulate and restrict the amount of gas delivered to the burner. The hole size in the orifice varies by the gas supply pressure and by the BTU rating of the burner. Grills equipped for LP gas operate at a much higher gas pressure and therefore have a smaller size orifice.

Hose and Regulator Inspection

Adjustment: The regulator is factory set at a specified outlet pressure of 11" of water column and is generally factory sealed and not adjustable. Do not try to adjust. The regulator can be checked by measuring the pressure with a manometer.

Vent Hole: There is a vent hole on top of the regulator. Check that it is clear of dirt and debris. If the hole is plugged, erratic and dangerous burning may result.

O-ring Seal: Before attaching the regulator to the cylinder, inspect the rubber O-ring on the P.O.L. fitting. Do not operate the grill if the O-ring is damaged or missing. Seal damage is common and we recommend replacement of the seal when the burner is replaced or when the seal is damaged. Cracks, splits or distortion will allow gas to escape. Additionally, the seal should be soft, pliable, and protrude slightly from the brass P.O.L. valve.

Chew Marks: The hose should be kept clean of grease and food drippings which attract squirrels and other animals. The animals will often eat the drippings on the hose and chew into the hose lining trying to get the last taste. Try cleaning the hose with an ammonia cleaner solution to minimize the attraction.

SAFETY HOSE AND REGULATOR

Propane Gas Models: Your barbecue is designed to operate on L.P. (Propane) gas at a pressure of 2.74 Kpa (11" water column). A regulator preset to this pressure is supplied with the barbecue and must be used.

This regulator is equipped with the Type-1 quick-closing connecting system, which incorporates these safety features:

- Will not allow gas to flow until a positive seal has been made.
- Has a thermal component that will automatically shut off the flow of gas between 115-150°C (240-300°F).
- Has a flow limiting feature, which will restrict the flow of gas to 10 cubic feet/hour.

Should the large, black thermal-sensitive coupling nut be exposed to any extreme temperatures above 115°C it will soften and allow the regulator probe to disengage from the valve, and will shut off the gas. Should this occur, **do not** try to reconnect the nut; instead replace the whole regulator assembly with a new one (see the attached parts listing for details). The regulator probe also contains a flow-sensitive feature, which limits the flow of gas to 10 cubic feet/hour, in the event of a regulator malfunction or hose leak. If the flow control feature is activated, the cause of this excessive gas flow should be investigated and corrected before using the barbecue again.

Note: Improperly lighting the barbecue can activate the flow control feature, resulting in lower heat output. If this occurs, the re-flow feature must be reset by turning all the burner controls and the cylinder valve off. Wait at least 30 seconds before slowly turning on the cylinder valve, and then after another 5 seconds turn the burner valve on and light the barbecue.

- Never connect this barbecue to an unregulated propane gas supply, or to another kind of gas. **Do not** alter or change the hose or regulator in any way.
- Visually inspect the whole hose assembly before each use for evidence of wear or damage such as cracks, burns, or cuts. If any damage is found, replace the assembly before using the barbecue. Use only the recommended replacement hose.
- To avoid possible damage to the hose, **do not** allow any grease or other hot materials to fall on the hose, and make sure the hose does not contact any hot surfaces of the barbecue.
- The connection fitting must be protected when it's disconnected from the cylinder. **Do not** allow the fitting to bump or drag on the ground as nicks and scratches could help create a leak when connecting back to the cylinder.
- It is important to do the "Leak Test" procedure every time a cylinder is refilled or any of the components are changed, and especially at the beginning of a new season.

To Reset The Gas Regulator Safety Device

1. Close the LP (propane) tank valve.
2. Turn all burner control knobs to the OFF position.
3. Disconnect the regulator from the LP tank.
4. Open the grill lid.
5. Open all of the control knobs to the high position.
6. Wait 2 minutes.
7. Close all of the control knobs.
8. Re-connect the regulator to the LP tank. Test for leaks.
9. With lid open, turn the left burner control knob to the "HIGH" position and then ignite the grill by turning Rotary ignitor clockwise.
10. Once lit, close the grill lid.
11. Wait for 10 to 15 minutes for the Barbecue to preheat.

ATTENTION: Proper start up and shut down procedures should be Followed to avoid regulator safety device activation.

WARNING

If the heat output is too low, the flow control feature may have been activated by a gas leak. If so, turn off the burner valve and cylinder valve, and perform the "Leak Test". If there aren't any leaks, re-light the burner.

SAFETY

LEAK TESTING

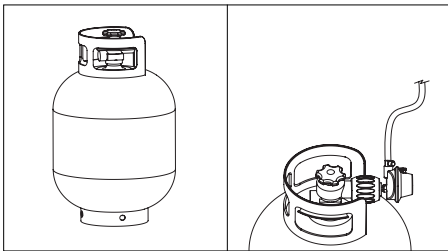

Drawing B

Drawing C

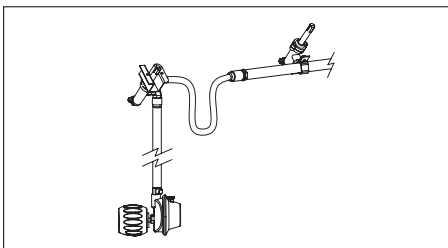

Drawing D

Perform a "Leak Test"

- Before lighting your barbecue for the first time.
- Every time the cylinder is refilled, or any component is replaced.
- At least once every year, preferably at the start of the season.

The "Leak Test" must be done outdoors, away from heat, open flames and flammable liquids. **Do not** smoke while performing the test. Use only a mixture of 50/50 liquid soap and water for leak testing. Never use a match or open flame.

The Following Must Be Checked

- The tank valve including the threads into the tank (Drawing C).
- All tank welds (Drawing B).
- Regulator fittings and tank connections (Drawing C).
- All hose connections (Drawing D).
- **With a newly filled and tested propane tank attached to the barbecue and all the barbecue controls turned "OFF", slowly open the cylinder valve one full turn.**
- **Using a brush and soap, soak all the connections and components listed above and shown in drawings B, C, D.**
- **Look carefully for bubbles forming, which is an indication of leaking gas.**
- **Tighten the connections at the bubbled areas until re-testing shows no indication of any leaks (shut off cylinder while correcting any leaks).**
- Shut off the cylinder valve and ensure all control valves are off.
- **Do not** use the barbecue if any leaks cannot be stopped. Turn off the gas cylinder valve, remove the gas cylinder and seek assistance from a qualified gas appliance service mechanic or gas dealer.

LIGHTING THE GRILL

Make Sure you have followed all the safety checks, procedures and instructions indicated in the previous section, before attempting to light the grill.

Lighting The Main Burners

1. Always open the hood completely and always inspect the grill and burners to confirm that all components are properly positioned before lighting the main burners.

W A R N I N G

Never stand with your head directly over the Barbecue when preparing to light the main burners, to prevent possible bodily injury.

2. Always confirm that all of the burner control knobs are in the OFF position before opening the gas supply.
3. Slowly turn on the propane gas supply valve at the tank 1-2 turns.
4. Wait approximately 5 seconds before turning the selected burner control to the HIGH position by pushing down on the knob and turning it counter-clockwise. This procedure allows pressure to stabilize, and prevents the flow limiting feature from being activated.
5. Immediately turn the Rotary Ignitor knob clockwise. As you turn the ignitor you will hear a click as the Piezo module generates an ignition spark to the burner. Rotate the ignitor knob until the burner lights. The selected burner should light within 5 seconds. Light the burners sequentially from left to right.

W A R N I N G

IF THE SELECTED BURNER DOES NOT LIGHT, immediately turn the burner control knob and cylinder valve to the OFF position, to prevent gas buildup. Wait five minutes for the gas to clear and then repeat the preceding starting procedure. IF the burner will not light when using the Ignitor, follow the match lighting instructions.

6. Confirm that the burner is properly lit. If the flame pattern is other than normal, consult the Troubleshooting Guide for corrective action.
7. Always preheat the Barbecue before starting to cook. Light all burners and adjust them to the HIGH position for 5-10 minutes. Before placing any food on the Barbecue, clean the cooking grids with a Porcelain cleaning brush.
8. Adjust the controls to a medium setting for most cooking requirements. A light coating of cooking oil on the cooking grids, before heating the grill, will prevent foods from sticking to the grill.

Turning The Burners Off

1. Always turn the burner control knobs to the off position when cooking has been completed.
2. Promptly turn OFF the gas supply valve at the propane cylinder.
3. Close the hood of the grill.

Match Lighting The Main Burners

1. Always open the hood completely and inspect the grill and burners to confirm that all components are properly positioned, before lighting the main burners.

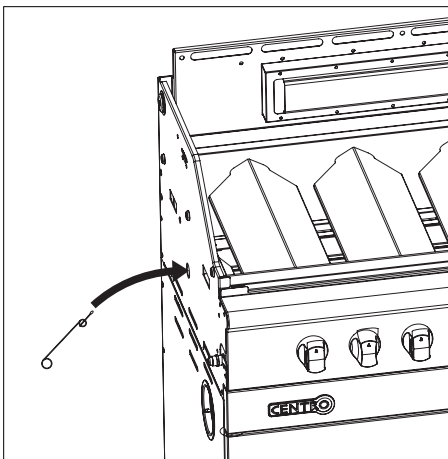

Drawing G

WARNING

Never stand with your head directly over the Barbecue when preparing to light the main burners, to prevent possible bodily injury.

2. Always confirm that all of the burner control knobs are in the OFF position before opening the gas supply.
3. Always turn on the propane gas supply valve at the tank (1-2 turns).
4. Insert a lit match or a butane lighter into the match lighting hole located on the lower left hand side of the firebox (Drawing G).
5. Turn the left burner control knob to the HIGH position by pushing on the knob and turning it counter-clockwise.

WARNING

If the heat output is too low, the flow control feature may have been activated by a gas leak. If so, turn off the burner valve and cylinder valve, and perform the "Leak Test". If there aren't any leaks, re-light the burner.

Lighting the Second Burner

- Turn the second control knob on the main control panel to the "HIGH" position. The unlit burner will automatically ignite.

Lighting the Side Burner

Use the push-button igniter on the main control panel and the right control knob on the side burner panel.

- Push in and turn the right control knob to the "HIGH" position.
- Push the igniter button until a loud click is heard, which is the spark being formed. Repeat several times if the burner does not light.
- If the burner does not light after several tries, turn the right control knob off and wait 5 minutes for the gas to clear.
- Repeat the above instructions. If the side burner still does not light, refer to the troubleshooting section for help or light the burner manually.

Note: The side burner is designed to accept a maximum weight of 20 lb. Do not overload the side burner.

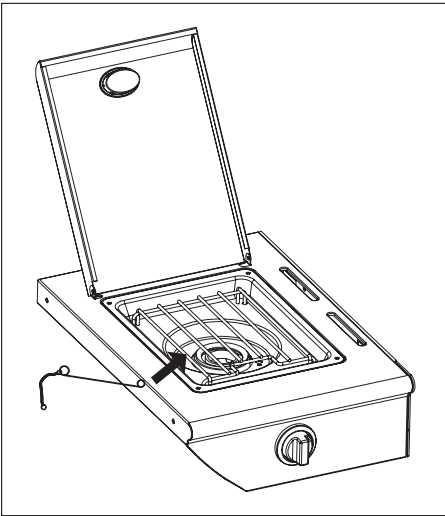

Lighting the Side Burner with a Match

- Place match in front ring of provided match holder.
- Place a lighted match through the hole to within 16 cm (1/2") of the side burner.
- Push in and turn the burner knob to the "HIGH" position. At this point, the burner should light, if it doesn't after 5 seconds, turn the control knob back to the "OFF" position and wait for the gas to clear.
- Wait 5 minutes, and then repeat the manual lighting procedure. If after three tries the burner still does not light, review the troubleshooting guide for help.

Shutting Down the Barbecue After Use

- Turn off the gas cylinder valve.
- Turn the burner control valve to the "OFF" position.

This sequence is important as it prevents residual gas from being left in the system under pressure and will make the next use easier.

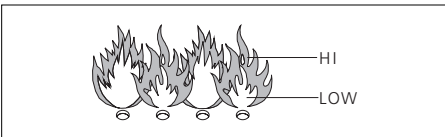

Visually Check Burner Flame

Take off the grates and heat shield. Light burners. Adjust the flame by turning the knobs from "HIGH" to "LOW". The flames will be smaller when the knobs are in the "LOW" position. Always check flame prior to each use. Perform flame check for side burner.

**SEAR ZONE
OPERATING
INSTRUCTIONS**

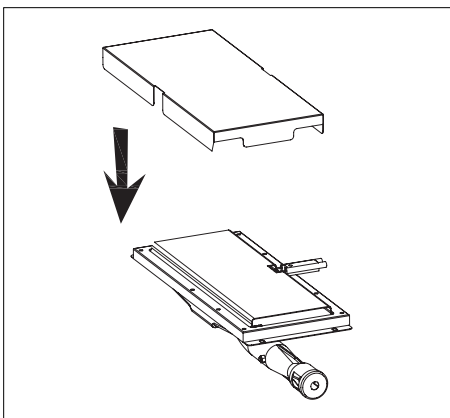
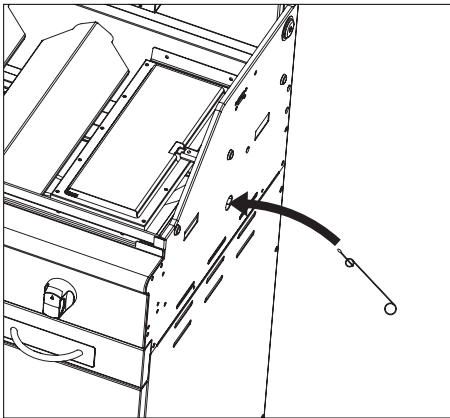
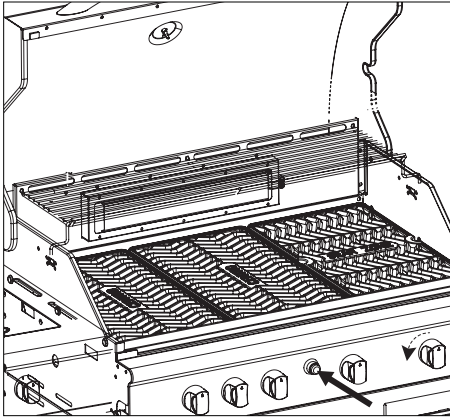

1. Follow all checking and lighting procedures of lighting main burners.
2. Turn the infrared burner knob to HIGH position.
3. Push the igniter button until a clicking sound is heard to light the infrared burner.
4. **There is no low flame adjustment on this burner.**

Follow the same manual lighting procedure to light the infrared burner by match.

When the BBQ is not in use, always cover the infrared burner cover to avoid burner disabled from moisture or rain. We suggest end users to use CENTRO grill cover as another protection for the infrared.

Operating an infrared burner

1. **Always keep the BBQ lid OPEN when the infrared burner is in use.**
2. **Do not use the infrared burner and the rotisserie burner simultaneously.**
3. **This burner is FOR SEARING ONLY!! Not for cooking!!**
4. **DO NOT use this burner to cook FAT MEAT.**

Serious grease fire might take place.

5. For steak or pork, sear each side for max 3 minutes to avoid from over cooked.
6. Use brush to clean the infrared burner before every use.

See the Centro Grilling Guide for further maintenance, operating, troubleshooting, and cooking tips.

ROTISSERIE BURNER OPERATING INSTRUCTIONS

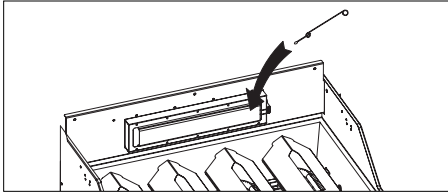

- Turn all knobs to “OFF”
- Open lid during lighting. Turn gas on at LP tank.
- Push in and turn Rotisserie Burner knob to “HI”.
- Push the Igniter. Be sure burner lights and stays lit.
- If Igniter does not work , follow match light instruction.

Match Lighting

- Open Lid. Turn on gas at LP tank.
- Place lit match near porthole of burner.
- Push in and turn Rotisserie Burner knob to “HI”. Be sure burner lights and stays lit.

TIPS ON USING YOUR ROTISSERIE

Guide to Rotisserie Cooking

Rotisserie cooking produces foods that are moist and flavourful. Most commonly used for cooking meat or poultry, the rotisserie is designed to cook food slowly. You can place a cooking pan beneath the food to collect juices for basting and gravy. To flavour the contents of the cooking pan you may add herbs, onions, or other spices of your choice.

Balancing the Food

In rotisserie cooking, balancing the food is of utmost importance. The rotisserie must turn evenly or the stopping and starting action will cause the food to cook unevenly and possibly burn the heavier side.

The easiest foods to balance are those of uniform shape and texture. To test if the food is balanced correctly when secured, place the ends of the rotisserie spit loosely in the palms of your hands. If there is no tendency to roll, give the spit a quarter turn. If it is still stable, give it a final quarter turn. It should rest without turning in each of these positions. It can then be attached to your grill.

Food Preparation

When preparing poultry, truss the birds tightly so that wings and drumsticks are close to the body of the bird. The cavity of bird may be stuffed prior to this. Pull the neck skin down and, using a small skewer, fix it to the back of the bird. Push the rotisserie spit through lengthwise, catching bird in the fork of the wishbone. Centre the bird and tighten with the holding forks. Test the balance as described before.

A rolled piece of meat requires the rotisserie skewer to be inserted through the centre of the length of meat, then secured and balanced.

For meats that contain bones, it is best to secure the rotisserie skewer diagonally through the meaty section. If protruding bones or wings brown too quickly, cover with pieces of foil.

MOONLIGHTS

WARNING

Only operate grill lights when your BBQ lid is open. Ensure BBQ light switch is in the off position when your BBQ lid is closed.

INFORMATION ON NATURAL GAS MODEL

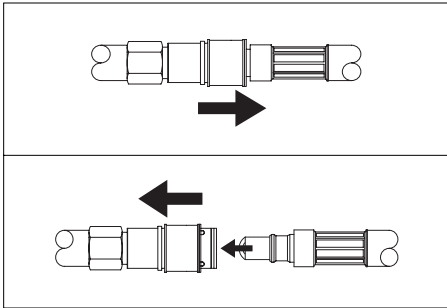

This model has a 12' hose with a male coupling plug that will allow you to attach your barbecue to your residential gas line.

WE STRONGLY RECOMMEND CONTACTING A CERTIFIED GAS-TECHNICIAN TO INSTALL YOUR NATURAL GAS UNIT.

Connecting to Gas Line

1. Pull back the outer sleeve located on the residential gas line (see illustration).
2. Insert the barbecue's male coupling plug into the residential gas line's coupling.
3. Push the male coupling plug in as far as possible, the outer sleeve will spring forward locking the two together (see illustration).

Disconnecting From Gas Line

- Pull back the outer sleeve located on the residential gas line and pull the barbecue's male coupling plug out.

Warning: Failure to follow all safety procedures could result in fire and explosion causing property damage, serious personal injury or even death.

Consult the rating label on the back of the barbecue to confirm that it is set up to burn natural gas. If the retracting sleeve on the residential gas line does not fit the barbecue's male coupling plug, the retracting sleeve can be replaced. All gas supply plumbing must be carried out by a qualified service agency. Modifications must be carried out in accordance with provincial authorities, and in accordance with CAN/CGA 1-B149.1 & 2 installation code requirements. A shut-off valve must be installed on the main line. Use a 3/8 or 1/2" gas line rated at least 75,000 BTUs.

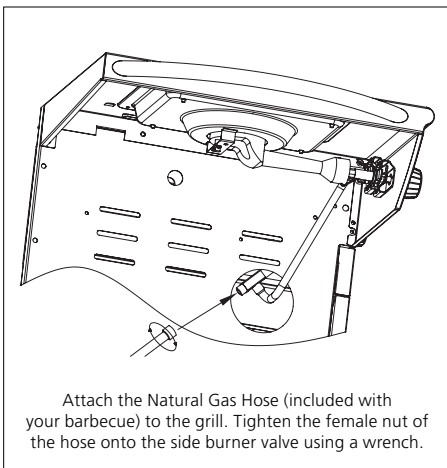

Before lighting for the first time, lighting for the first time each season, and after making any adjustments, do the following:

- Make sure all burner control knobs are in the "OFF" position.
- Always connect the barbecue's gas line to the residential gas line before opening the shut-off valve.
- Perform a "Leak Test". This test must be performed outdoors, away from heat, open flames and flammable liquids. **Do not** smoke while doing the test. Use only a mixture of liquid soap and water. Use a spray bottle or brush to apply the soapy solution to all the connection points. Check carefully for bubbles forming, which is a sign of leaking gas. If you have a leaky connection, turn the gas off, tighten the connections, turn the gas back on and retest. **Do not** use the barbecue if any leaks cannot be stopped. If you can't stop a leak, turn the gas off and get assistance from a qualified service technician. Never use a match or open flame.

Natural Gas Supply Connection

Always disconnect the Grill and close its individual manual shutoff valve, when conducting pressure tests of the gas supply piping system at pressures which exceed 1/2 psi (3.5kPa).

- Always isolate the Grill from the gas supply piping system by closing its individual manual shutoff valve when conducting pressure tests of the gas supply piping system at pressures which are equal to or less than 1/2 psi (3.5kPa).

**PARTS LISTING FOR
85-1087-6 (PROPANE) (G61003)**

Item No.	Quantity	Specification	Part No.
A	1	Top Lid Assembly	
AA	1	Top Lid Weldment	G610-2100-01
AB	2	Handle seat for Top Lid Handle	G610-0035-01
AC	1	Top Lid Handle	G610-5200-01
AD	1	Lighting System	G610-5300-01
AE	1	Thermometer	G413-0029-01
AF	2	Screw for Top Lid	G607-0002-01
B	1	Burner Box Assembly	
BA	1	Burner Box Weldment	G610-0200-01
BB	1	Heat Shield A	G610-0016-01
BC	1	Backburner Brace B	G610-0017-01
BD	1	Rotisseries Burner	G610-6000-01
BE	1	Smoker Box	G610-6600-01
BF	2	Main Burner A	G607-0700-01
BG	1	Main Burner B	G502-1800-01
BH	1	Infrared Burner	G610-5000-01
BI	1	Carryover Assembly	G607-0006-02
BJ	3	Flame Tamer	G607-0005-01
BK	1	Infrared Burner Main Shield	G610-0013-01
BL	2	Cooking Grate-A, Burner box	G610-0002-01
BM	1	Cooking Grate-B, Sear Zone	G610-0003-01
BN	1	Warming Rack	G610-0001-01
BO	1	Rotisserie Assembly	G610-2900-01
CA	1	Manifold Assembly	G610-5600-01
CB	1	Regulator	G602-0050-01
CC	1	Side burner valve	G610-0038-01
CD	1	backburner valve	G610-0026-01
CE	1	Control panel	G610-0014-01
CF	6	control knob	G610-0015-01
CG	1	Electronic Ignition Kit	G610-3300-01
CH	1	Upper Brace	G610-6300-01
CI	1	Left Rail, Grease Tray	G607-0033-01
CJ	1	Right Rail, Grease Tray	G607-0034-01
CK	1	Grease Tray	G610-6400-01
CL	1	Upper rear panel	G610-0042-01
CM	1	heat shield, tank	G610-0020-01
CN	1	Condiment basket	G607-0031-01

Item No.	Quantity	Specification	Part No.
D	1	Side Shelves Assembly	
DA	1	Side Burner Shelf Weldment	G610-5800-01
DB	2	Towel Bar	G610-0039-01
DC	1	Side Burner Drip pan	G401-0300-01
DD	1	Cooking Grate, side burner	G502-0064-01
DE	1	Digital Grilling System	G610-4800-01
DF	1	Side burner	G401-0033-01
DG	1	Lid for side burner	G409-0008-02
DH	1	match holder	G608-0019-01
DI	1	Side Shelf Weldment	G502-2900-01
DJ	1	Condiment Basket	G502-0065-01
E	1	Cart Assembly	
EA	1	Left side panel	G610-5400-01
EB	1	Right side panel	G610-5500-01
EC	1	tank back panel	G610-0043-01
ED	1	cabinet left panel	G610-0044-01
EE	1	Cabinet back panel	G607-0029-01
EF	1	bottom Shelf	G610-5900-01
EG	1	Door Assembly, Left	G610-9700-01
EH	1	Door Handle	G413-0016-01
EI	2	Drawer	G610-6500-01
EJ	1	Base Kit Tank	G610-0046-01
EK	1	Tank supporter	G610-6200-01
EL	2	Caster Assembly with Lock	G401-0061-01
EM	2	Caster Assembly	G606-0027-01

85-1087-6 (PROPANE) (G61003)

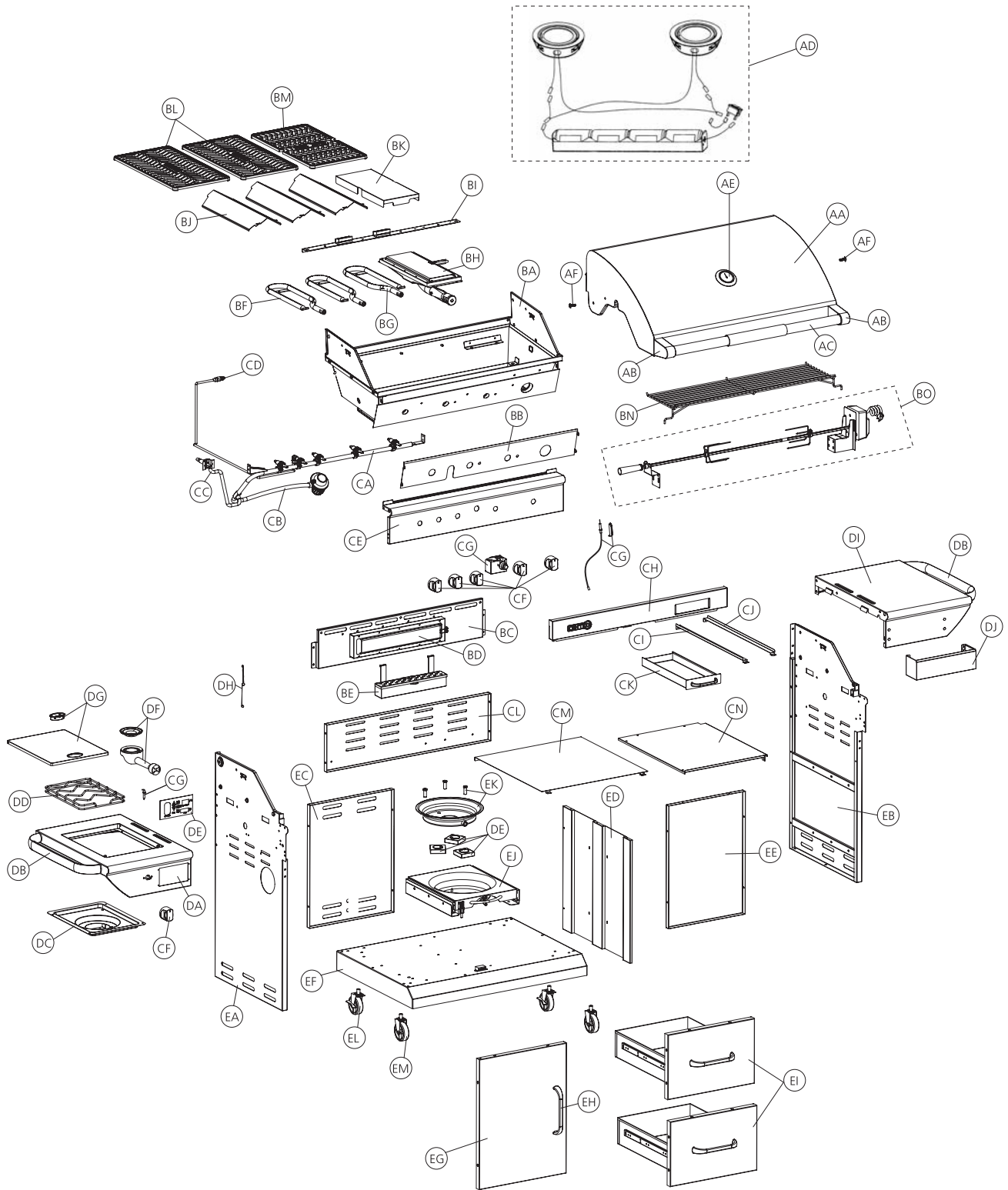

**PARTS LISTING FOR
85-1088-4 (NATURAL GAS) (G61004)**

Item No.	Quantity	Specification	Part No.
A	1	Top Lid Assembly	
AA	1	Top Lid Weldment	G610-2100-01
AB	2	Handle seat for Top Lid Handle	G610-0035-01
AC	1	Top Lid Handle	G610-5200-01
AD	1	Lighting System	G610-5300-01
AE	1	Thermometer	G413-0029-01
AF	2	Screw for Top Lid	G607-0002-01
B	1	Burner Box Assembly	
BA	1	Burner Box Weldment	G610-0200-01
BB	1	Heat Shield A	G610-0016-01
BC	1	Backburner Brace B	G610-0017-01
BD	1	Rotisseries Burner	G610-6000-01
BE	1	Smoker Box	G610-6600-01
BF	2	Main Burner A	G502-1700-01
BG	1	Main Burner B	G502-1900-01
BH	1	Infrared Burner	G610-5000-01
BI	1	Carryover Assembly	G607-0006-02
BJ	3	Flame Tamer	G607-0005-01
BK	1	Infrared Burner Main Shield	G610-0013-01
BL	2	Cooking Grate-A, Burnerbox	G610-0002-01
BM	1	Cooking Grate-B, Burnerbox	G610-0003-01
BN	1	Warming Rack	G610-0001-01
BO	1	Rotisserie Assembly	G610-2900-01
CA	1	Manifold Assembly	G610-4400-01
CB	1	Natural Gas Hose Kit	G411-0084-01
CC	1	Sideburner valve	G610-0041-01
CD	1	backburner valve	G610-0026-01
CE	1	Control panel	G610-0014-01
CF	6	control knob	G610-0015-01
CG	1	Electronic Ignition Kit	G610-3300-01
CH	1	Upper Brace	G610-6300-01
CI	1	Left Rail, Grease Tray	G607-0033-01
CJ	1	Right Rail, Grease Tray	G607-0034-01
CK	1	Grease Tray	G610-6400-01
CL	1	Upper rear panel	G610-0042-01
CM	1	heat shield, tank	G610-0020-01
CN	1	cabinet top panel	G607-0031-01

Item No.	Quantity	Specification	Part No.
D	1	Side Shelves Assembly	
DA	1	Side Burner Shelf Weldment	G610-5800-01
DB	2	Towel Bar	G610-0039-01
DC	1	Side Burner Drip pan	G401-0300-01
DD	1	Cooking Grate, side burner	G502-0064-01
DE	1	Digital Grilling System	G610-3800-01
DF	1	Side burner	G401-0033-01
DG	1	Lid for side burner	G409-0008-02
DH	1	match holder	G608-0019-01
DI	1	Side Shelf Weldment	G502-2900-01
DJ	1	Condiment Basket	G502-0065-01
E	1	Cart Assembly	
EA	1	Left side panel	G610-5400-01
EB	1	Right side panel	G610-5500-01
EC	1	tank back panel	G610-0043-01
ED	1	cabinet left panel	G610-0044-01
EE	1	Cabinet back panel	G607-0029-01
EF	1	bottom Shelf	G610-5900-01
EG	1	Door Assembly, Left	G610-9700-01
EH	1	Door Handle	G413-0016-01
EI	2	Drawer	G610-6500-01
EJ	2	Caster Assembly with Lock	G401-0061-01
EK	2	Caster Assembly	G606-0027-01

85-1088-4 (NATURAL GAS) (G61004)

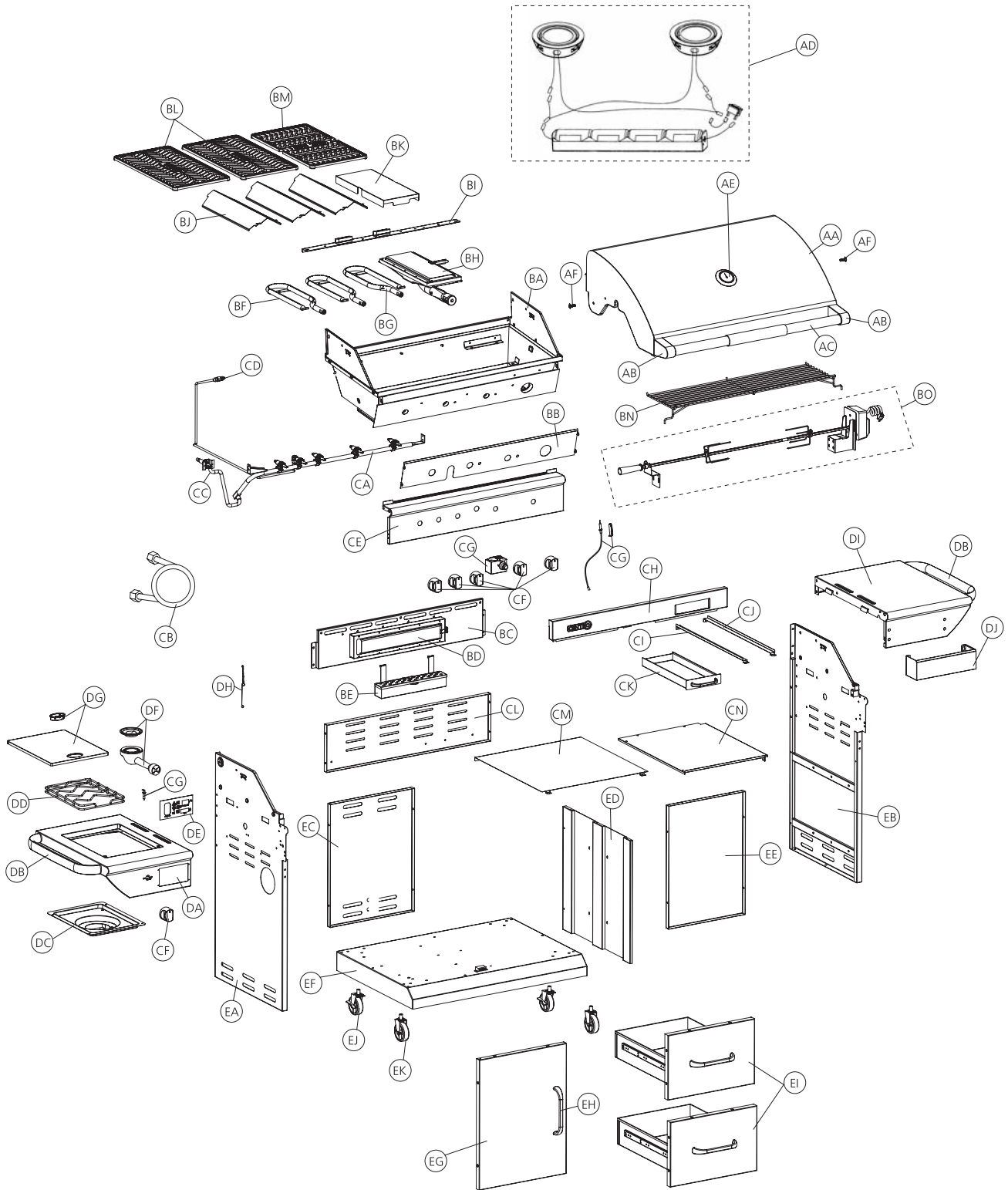

ASSEMBLY INSTRUCTIONS

Tools Needed for Assembly

- #2 Phillips® screwdriver
- Pliers
- 1/4" slotted screwdriver
- Rubber mallet
- Adjustable wrench

Before assembling the barbecue, read these instructions carefully. Assemble the barbecue on a flat, clean surface. Grill is heavy. You should have two people assemble the barbecue together.

Notes: Do not fully tighten all the nuts during this initial stage.

Caution: Sheet metal can cause injury. Wear gloves when installing the grill. Use care when assembling.

Hardware Pack List

No.	Description	Part Number	Quantity
1	1/4" -20UNC x 13 Screw	20120-13013-250	6
2	Ø7 Washer	40300-07000-250	6
3	Ø7 Lock Washer	41400-07000-250	6
4	No.10-24UNC x 10 Screw	20124-10010-250	6
5	Ø5 Washer	40300-05000-250	6
6	Ø5 Lock Washer	41400-05000-250	6
7	AA Battery	G401-0088-9000	1
8	ST 3.0 Self Tapping Screw (for assembling digital system box)		4
9	Light bulbs		2
10	D battery- Lighting system		4
11	9 volt Battery- Digital System		1

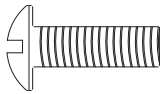

#1 – 1/4" x 13 mm Screw (x6)

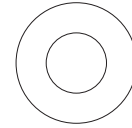

#2 – Ø7 Flat Washer (x6)

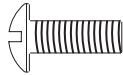

#4 – No. 10 x 10 Screw (x6)

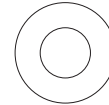

#5 – Ø5 Flat Washer (x6)



#6 – Ø5 Lock Washer (x6)

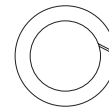

#3 – Ø7 Lock Washer (x6)

Fig. 1

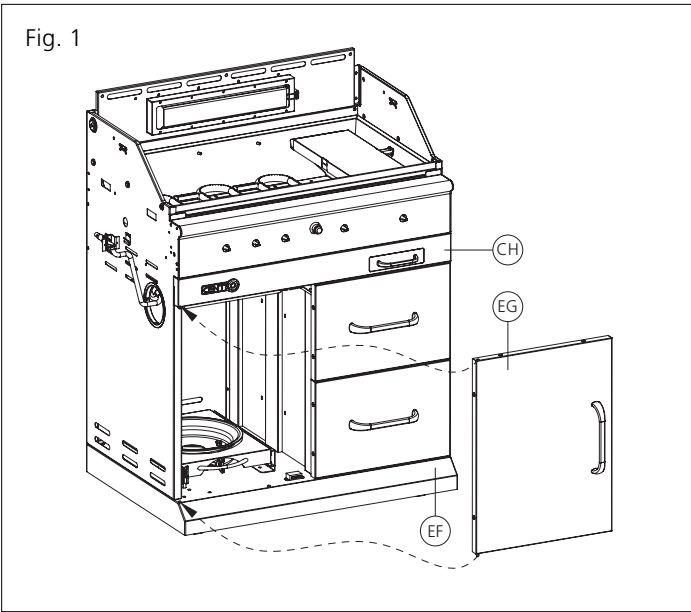

1

Assemble the left door (EG) to the cart as shown. Place the bottom door hinge into the hole located on the bottom shelf (EF). Then press in the top hinge to mount the door to the upper brace (CH).

Fig. 2

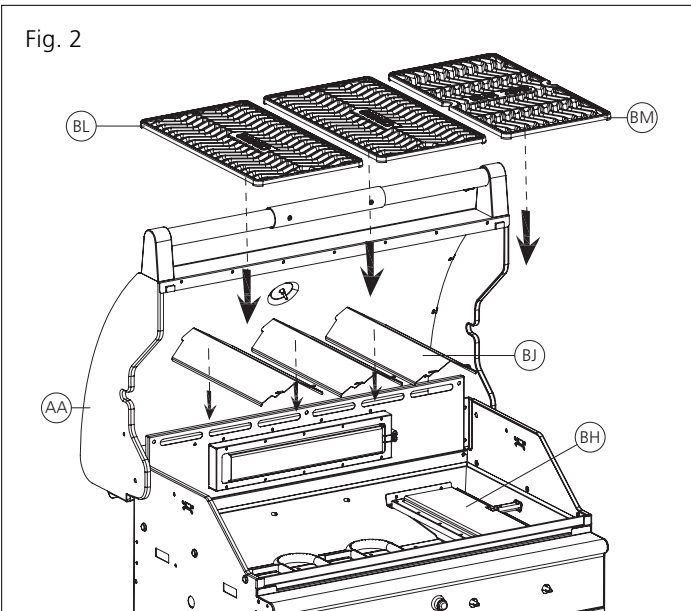

2

Open the Lid (AA). Place the 3 flame tamers (BJ) over top of the burners as shown. Ensure that all flame tamers are inserted into the front grooves located on the front of the Burner box. Place the two cooking grates (BL) and the sear zone cooking grate (BM) as shown.

Fig. 3

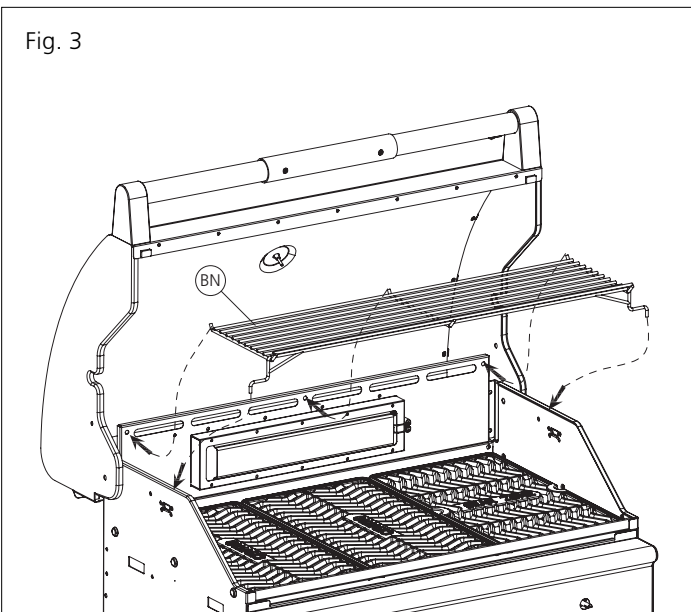

3

Place the warming rack (BN) into the two holes located on the backburner brace (BC) as shown. Make sure the two legs on the warming rack are placed onto the edge of the burner box (BA).

Fig. 4

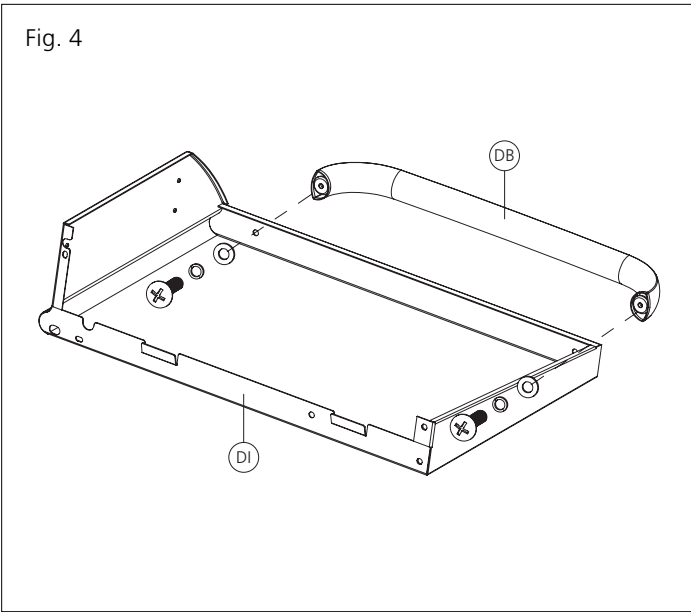

4

Remove the screws and washers from the side shelf towel bars (DB). Assemble the towel bars (DB) to the side shelf (DI) and side burner shelf (DA) using the same screws and nuts which were just removed.

Fig. 5

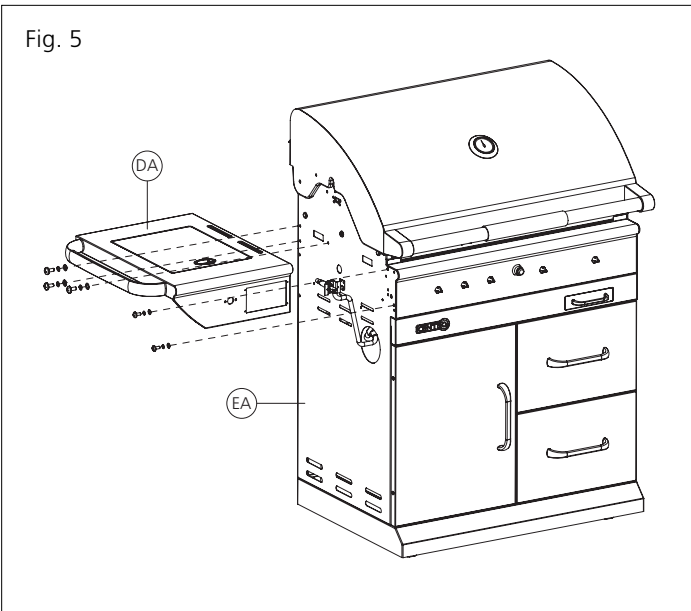

5

Assemble the side burner shelf (DA) to the left side panel (EA) using hardware #1, #2, and #3 (x3) and #4, #5, and #6 (x2). Assemble the side shelf (DI) to the right side panel (EB) by using the same hardware above. Do not fully tighten all screws while assembling. Make sure the shelves are well fitted with the side panels before tightening.

Fig. 6.1

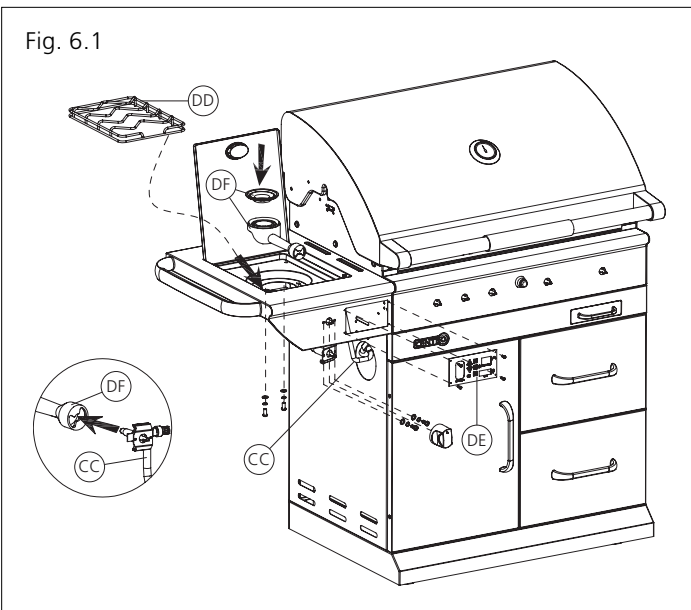

6.1

Insert the side burner valve stem (CC) and mount it using the screws and nuts attached to the valve bracket hardware #4, #5, and #6 (x2) and guide through the side burner shelf control panel. Attach the control knob (CF) to the valve stem with the triangle sign on the knob pointing upward. Insert the side burner (DF) into the side burner drip pan (DC). Gently place the burner over the orifice of the valve. Place the side burner grate (DD) in position as shown.

Attach the Digital Grilling System (DE) to the side burner shelf control panel as shown using hardware #8 (x4). Then place the digital system control panel sticker onto the system (fig.6.2).

Fig. 6.2

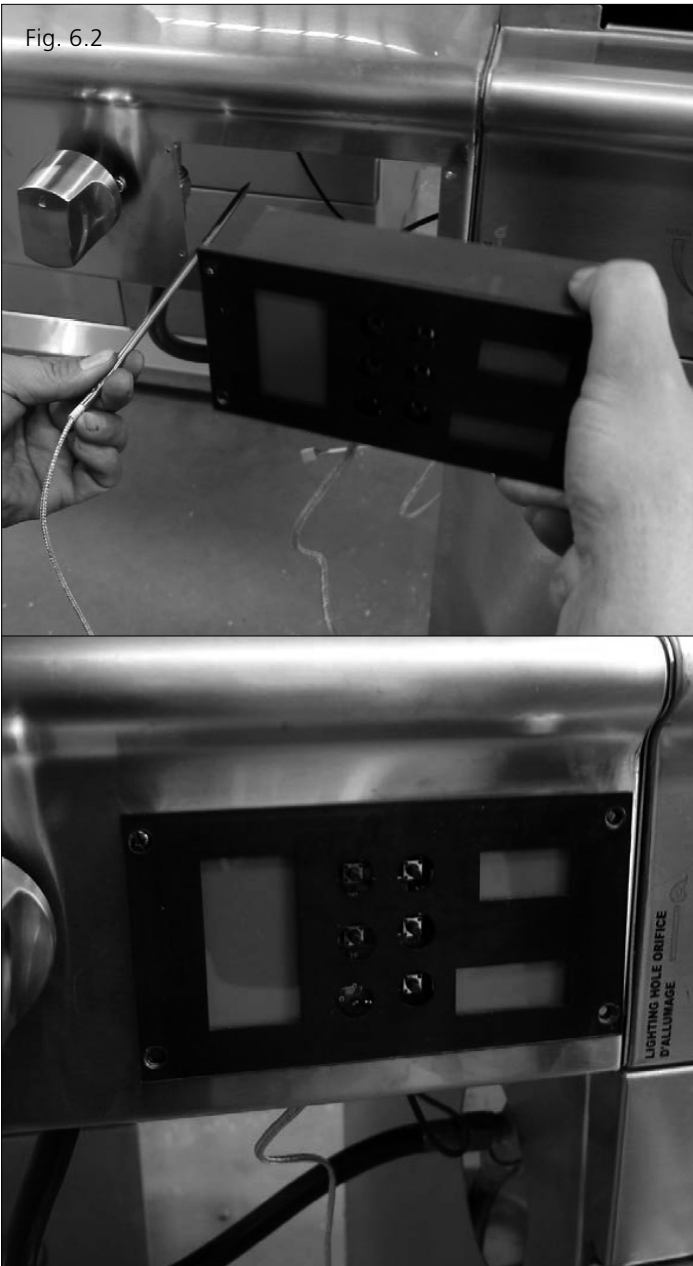

6.2

Place the Digital System Assembly into the hole on the side burner control panel. Remember to place the Temperature probe into the hole first, as shown in the image.

Fig. 6.3



6.3

Using 3.0 self tapping screws (x4) (hardware number #8) attach the Digital System onto the side burner control panel as shown.

Fig. 6.4

6.4

Place the Control panel sticker onto the Digital System as shown.

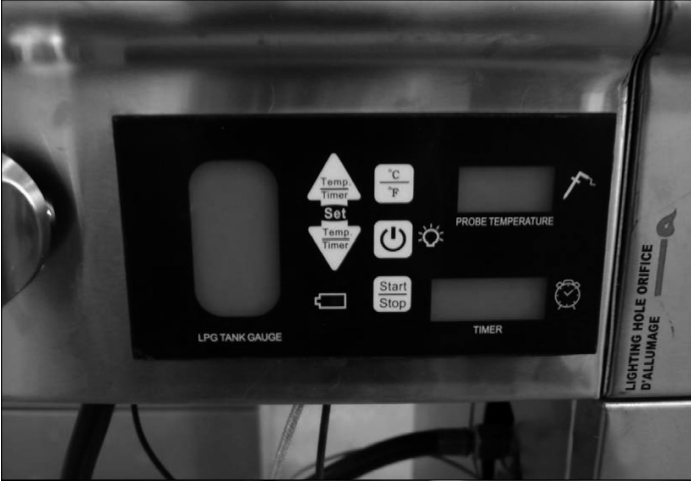

Place the temperature probe into the holding clip located under the Side burner Side shelf.



The Digital System uses a 9V battery (x1) which is pre-assembled at the factory. End users can replace the battery as often as needed by removing the battery compartment cover located on the rear of the Digital System, and replace the battery.

The Moonlights and Grilling System operate independently.

Fig. 6.5

6.5

The end user must connect the wire from the load cell to the bottom side of the digital system box.

The 3 load cells are located under this plate.

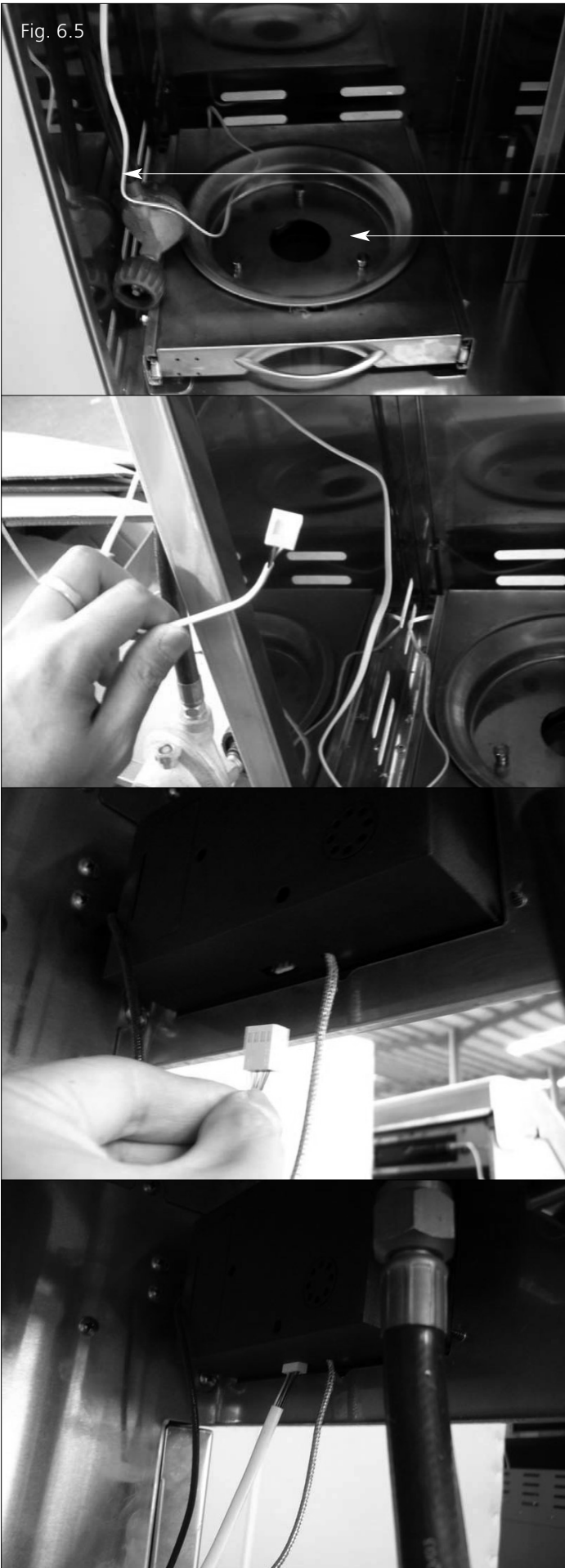

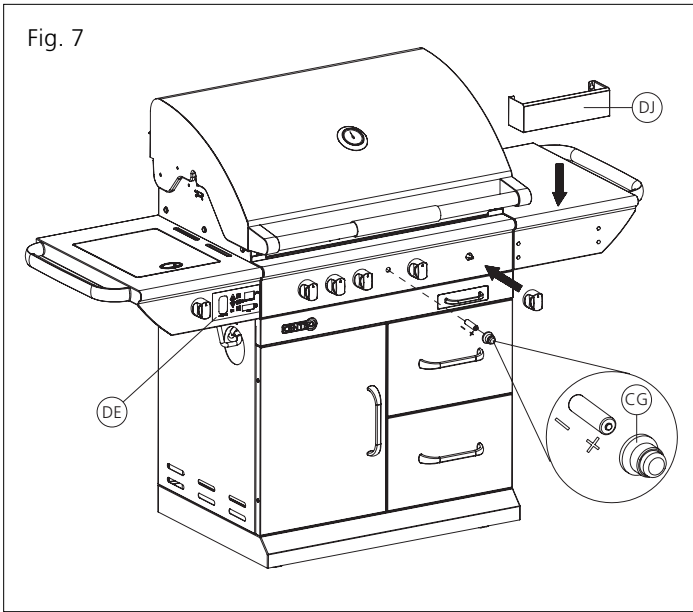

7

Attach all remaining control knobs (CF) onto all valve stems located on the control panel (CE). Then position the front condiment basket (DJ) to the side shelf front panel (DI) by fitting the holes of the condiment to the bracket on the side shelf, as shown.

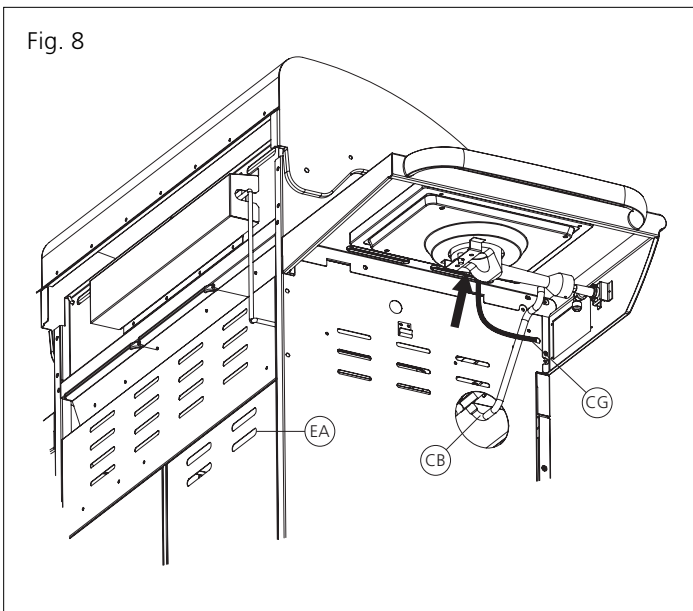

8

Attach the side burner igniter wire (CG) as shown. Ensure the wire is pushed in at both ends correctly. Insert regulator (CB) through the hole located in the cart side panel (EA) as shown.

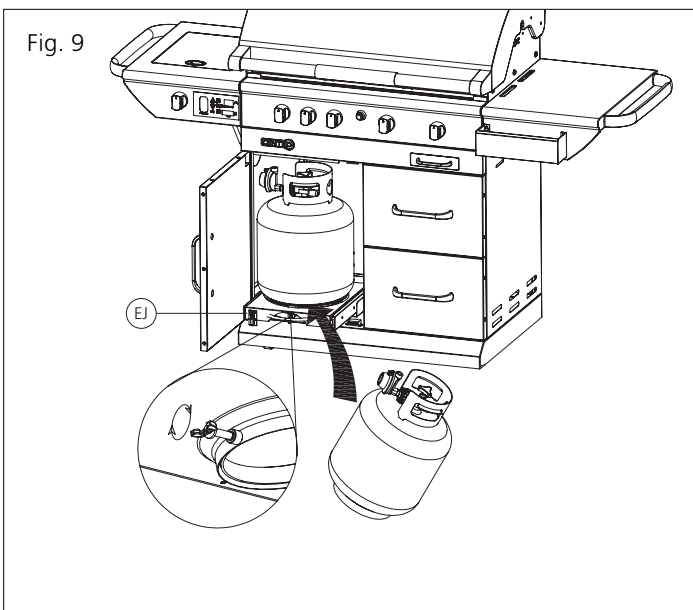

9

For propane model only (85-1087) secure 20lb tank onto the tank pull out tray (EJ) using screws attached. Then attach regulator valve to gas tank by hand tightening **only**.

Warning: Do not store extra LP tank in the BBQ cart.

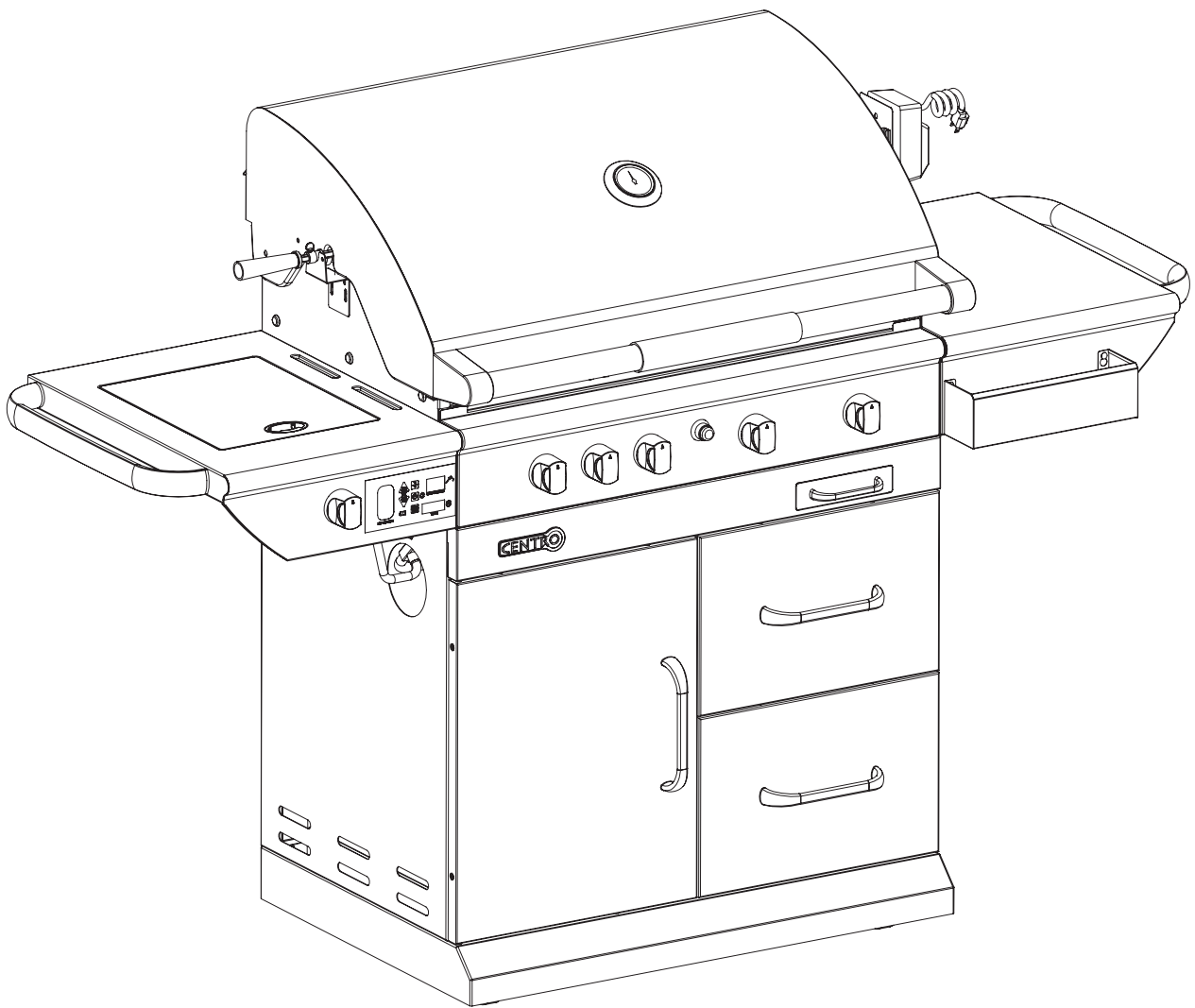

DISTRIBUTOR

Trileaf Distribution Trifeuil
Toronto, Canada
M4S 2B8

CENTRO