

Cal Flame
A Division of Lloyds Material Supply, Inc.

2008 OWNER'S MANUAL

220V Electric Grill and Cart

Manufactured after December 1, 2007 • United States and Canada
© 2008 Lloyds Material Supply, Inc.



Due to our continuous improvement programs, all models, operation, and/or specifications are subject to change without prior notice.

www.calspas.com

LTR20081037, Rev. B
6/20/08

This manual applies to the Cal Flame Electric Grill, model BBQ07871E and the Cal Flame Electric Grill Cart, model BBQCR07900E.

Save these instructions!

Read all instructions before you operate your grill.

Instructions For Installation	1
Proper Electric Supply	1
Supply Connection	1
Cabinet Cut-out Dimensions	1
Connecting Power to the Grill or Cart	2
Safety Instructions	3
Using Your Electric Grill	5
Heating Elements	5
Grill Operation	5
Care and Maintenance	6
Cooking Grates	6
Hood and Body	6
Storage	6
Drip Pan	6
Care of Stainless Steel	6
Covering Your Cart or Grill	6
After Use Care	6
Electric Grill Wiring Diagram	8
Warranty Information	10

Copyright 2007-2008 Lloyds Material Supply, Inc.
All rights reserved. Duplication without written consent is strictly prohibited.

Cal Flame™ is a registered trademark.

Due to continuous improvement programs, all models, operation, and/or specifications are subject to change without prior notice.

LTR20081037, Rev. B
6/20/08

CONTACT INFORMATION

For customer service, please contact your authorized dealer immediately. If you need additional information and/or assistance, please contact:

L.M.S. Customer Service Department
1462 East Ninth Street
Pomona, CA 91766.

Toll Free: 1-800-CAL-SPAS
Fax: 1-909-629-3890

Instructions For Installation

Proper Electric Supply

Save these instructions for local electrical inspector's use.

You must provide an adequate electrical supply system as required for your grill. All wire connections must be in accordance with local codes and properly insulated. Check with local utility for governing electrical codes and ordinances. In absence of local electrical codes, the National Electrical Code, NFPA No. 70, must be followed. A copy of the National Electrical Code, NFPA No. 70, can be obtained by writing to:

National Fire Protection Association
Batterymarch Park
Quincy, Massachusetts 02269

It can also be found at the NFPA web site at www.nfpa.org.

Your 240V electric grill is required to have a dedicated 30 amp breaker with three #10 AWG copper wires. This will include a black and a red wire for your incoming power and a green wire for your ground. Electrical service should only be wired by a licensed electrician. Breakers vary in appearance and wire locations. Before wiring load and feed wires to the breaker, verify they are being connected to the proper poles.

Always follow applicable local, state, and federal codes and guidelines.

Supply Connection

All electrical connections are to be protected from the elements and be in accordance with local codes for outdoor wiring. This appliance is to be permanently wired.

Most cities and counties require permits for exterior construction and electrical circuits. In addition, some communities have codes requiring residential barriers such as fencing and/or self-closing gates on property to prevent unsupervised access to the property by children under the age of five. Your dealer can provide information on which permits may be required and how to obtain them prior to the delivery of your equipment.

We recommend the installation, adjustment and service of your new grill be performed by L.M.S. qualified installers and service technicians to ensure proper operation and prevent accidents.

When determining a suitable location, consider factors such as exposure to wind, proximity to traffic paths, and windows that open into the home.

Locate barbecue grills and stainless steel carts only in well-ventilated areas and only on solid, flat foundations (e.g. deck or cement slab). Do NOT place stainless steel carts on dirt or grass.

Cabinet Cut-out Dimensions

Your Cal Flame™ grill is designed for easy installation into a non-combustible enclosure. The supporting deck or counter must be flat and level. When determining the final location of your grill, adequate cross ventilation must be present to prevent gas from being trapped in the event of a leak.

The drawings below show the cabinet cut-out dimensions you will need.

Width	Depth	Height
23 1/4"	22 1/4"	9 1/4"

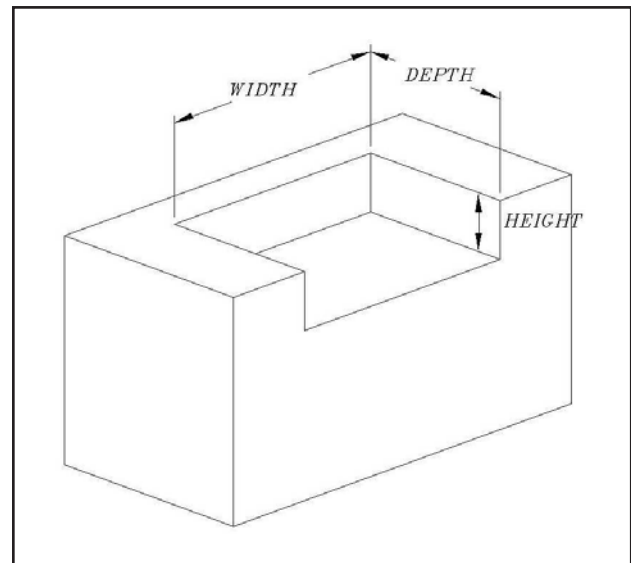

Connecting Power to the Grill or Cart

These instructions apply to both the 220V electric grill and grill cart.

Owners of the 220V electric grill cart will need a second person to help them.

1. Lift the grill up from the cart and bring it forward about 10 to 12 inches. You will see a small electrical junction box behind the grill.

Grill owner's do not need to do this. When have removed all packaging from the grill, place the grill on a solid surface. The junction box will be accessible directly behind the grill.

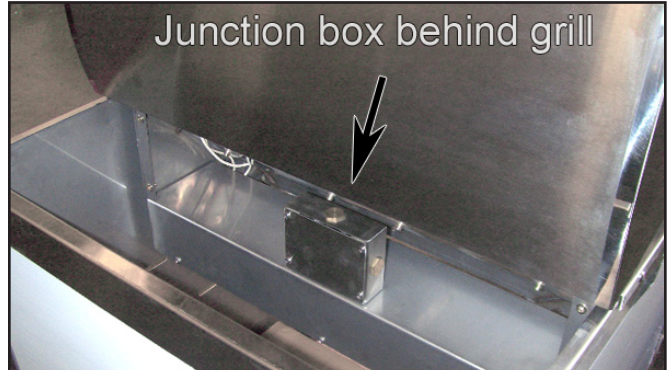

2. Using a Phillips head screwdriver, remove the screws from the access plate.
3. Insert a 220V power cable through one of the holes in the back (left or right side).



4. Remove the brass caps on the sides of the junction box and insert the power cables.
5. Attach power cable to wires in junction box with twist-on wire connectors.
6. Replace the cover. For cart owners, carefully move the grill back into place.

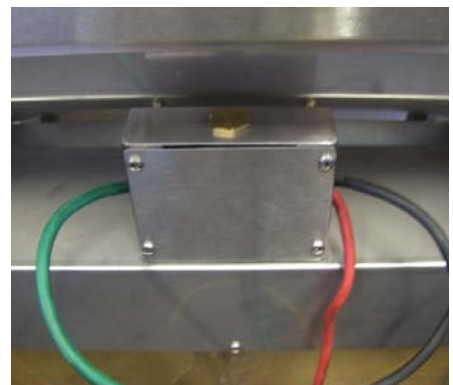
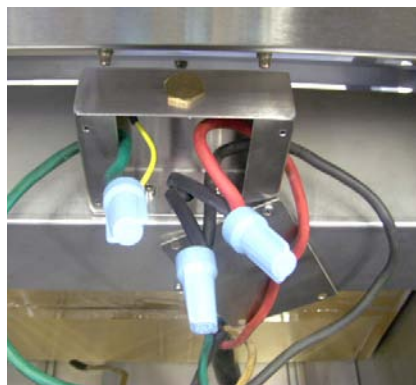
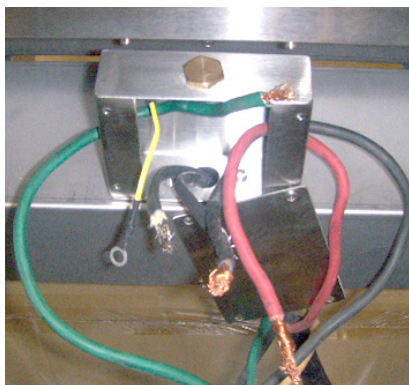

Safety Instructions

This grill is for household use only. Use the grill only for its intended purpose as described in this guide.

Read and follow all instructions before using this appliance to prevent the potential risk of fire, electric shock, personal injury or damage to the appliance as a result of improper usage of the appliance. Improper installation, adjustment, alteration, service or maintenance can cause injury or property damage.

Placement and Location

- **Cal Flame™ grills are designed for outdoor use only.**
- Never locate this appliance in an enclosed room, under a sealed overhead structure, or in any type of enclosed area such as a garage, shed, or breezeway. Keep clear of trees and shrubs.
- Do not place this grill under or near windows or vents that can be opened into your home.
- Cal Flame™ grills are not intended for installation in or on recreational vehicles or boats.
- Maintain sufficient distance as to not overheat any overhead combustible material such as a patio cover.
- The area surrounding your new grill should be kept clean and free from flammable liquids and other combustible materials such as mops, rags or brooms, as well as solvents, cleaning fluids, and gasoline.
- Do not use the grill, grill cabinet, or area surrounding the grill as a storage area for flammable or plastic items.
- Your Cal Flame™ grill must be permanently wired to a dedicated three-wire, single phase, AC 240 volt or 208 volt, 60 cycle electrical system.
- Do not use an extension cord to supply power to your Cal Flame™ grill. Such use may result in fire, electrical shock or other personal injury.
- Do not install a fuse in the neutral or ground circuit. A fuse in the neutral or ground circuit may result in an electrical shock hazard. Do not ground this appliance to a gas supply pipe or hot water pipe.
- To prevent fire and smoke damage, remove all packaging material before operating grill.
- Before you start cooking, clean the entire grill thoroughly with hot, soapy water. This is necessary to remove residual solvents, oil and grease used in the manufacturing process. The grates should also be thoroughly cleaned in the same manner.

Operation

Set-Up

- Before installing built in grills in enclosures, copy all product information such as model number, serial number and store information in a safe place. This information is located on a plate located behind the grill and is visible when the hood is lowered or on the right side of the chassis. There is an area on the back cover of this manual where you can write down this information.
- We recommend that a licensed contractor install your Cal Flame™ grill. Installation must conform to local codes, or in the absence of local codes, the *National Electrical Code, NFPA No. 70*.
- Do not use grill for other than intended use.
- Never use the grill if the drip pan is not properly installed. Drip pan should be pushed all the way to the rack located just under the grill. Fire or explosion can result from an improperly installed drip pan.
- Never line the grill or side burners with aluminum foil.
- Do not use fuel such as charcoal briquettes in an electric grill.
- Never leave the grill unattended when in use.
- When using the grill, do not touch the grill rack, burner grate, or immediate surroundings as these areas become extremely hot and can cause burns. Use handles or knobs.

- Do not heat any unopened glass or metal container of food on the grill. Pressure may build up and cause the container to burst, possibly resulting in serious personal injury or damage to the grill.
- Do not reach over your grill or any other surfaces when hot or in use.
- Do not operate the grill with a damaged heating element.
- Turn off controls when cooking is completed.
- Do not allow grill-racks to become overloaded with grease. Clean frequently.
- Do not cover grates completely with meat. Leave air space between each steak, etc. to allow proper ventilation as well as prevent flare-up.

Maintenance and Repair

- Unless specifically recommended in this manual, do not repair or replace any part of the grill except as specifically recommended in this manual. A qualified technician should perform all service. Any repairs made by a non-L.M.S. approved dealer technician will void your warranty.

Precautions Regarding Children

- Never leave children unattended in the area where the grill is being used. Close supervision of children is necessary when any appliance is use near children.
- Do not store items of interest to children around or below the grill. Children climbing on appliance to reach items could damage the appliance or be burned or seriously injured.
- Never allow children to sit or stand on any part of the grill.
- Children must be taught that the appliance and utensils in or on it can be hot. Let hot utensils cool in a safe place, out of reach of small children. Children should be taught that an appliance is not a toy. Children should not be allowed to play with controls or other parts of the unit.

In Case of Fire

- **Do not use water on grease fires.**
- Turn the appliance off and smother the flaming pan with a tight-fitting lid, a cookie sheet or a flat tray.
- For flaming grease outside of the pan, smother it with baking soda or use a dry chemical or foam-type fire extinguisher.
- Never pick up a flaming pan.

Using Your Electric Grill

Read all instructions before you operate your grill.

This appliance has been tested for safe performance using conventional cookware. Do not use any devices or accessories that are not specifically recommended in this manual. The use of devices or accessories that are not expressly recommended in this manual can create serious safety hazards, results in performance problems, and reduce the life of the components of this appliance.

Aerosol-type cans are **EXPLOSIVE** when exposed to heat and may be highly flammable. Do not use to store near appliance.

Clean only parts listed in this guide and use procedures recommended.

Remember to use your Cal Flame grill safely by following these reminders:

- It is dangerous to use barbecue grills in any manner other than for what it is designed for.
- Do not use charcoal in an electric grill.
- Do not heat sealed containers such as cans or jars on grills or side burners. Explosion may result resulting in injury or death. Any sealed container, such as a pressure cooker, must have a properly operating pressure relieve valve to minimize explosion hazard.
- Never put combustible material such as paper, cloth, or flammable liquids on your grill at any time. Do not use grill, side shelves, cabinets, or any area around grill to store flammable materials.

Heating Elements

Never touch surface elements or areas near elements. Heating elements may be hot even though they are dark in color. Areas near surface elements may become hot enough to cause burns.

During and after use, do not touch or let clothing to other flammable materials contract heating elements or areas near elements until they have had sufficient time to cool.

Do not soak removable heating elements. Heating elements should never be immersed in water.

Other potentially hot surfaces include: Cooktop and areas facing cooktop.

Grill Operation

Before the first use, wash your new grill grates in hot soapy water, rinse and dry. "Season" the surface by wiping on a thin coating oil. Remove excess oil by wiping with paper towel. This procedure should be repeated either when you clean it in the dishwasher or any time you use a sugar-based marinade (for example, barbecue sauce).

- Preheat the grill on high for 5-10 minutes. Preheating improves the flavor and appearance of meats and quickly sears the meat to help retain the juices.
- Excessive amounts of fat should be trimmed from meats. Only a small amount is necessary to produce the smoke needed for that smoked, "outdoor" flavor. Excessive fat can create cleaning and flare-up problems.
- Allowing excessive amounts of grease or drippings to constantly flare-up voids the warranty on the grill grates.
- Excess flare-ups indicate that either the grill interior needs to be cleaned or that excessive amounts of fat are in the meat or the meat was not properly trimmed.
- Grease drippings will occasionally ignite to produce harmless puffs of flame for a second or two. This is a normal part of the cooking process.
- Never leave grill unattended during grill operation.
- Should excess grease cause sustained flare-ups, remove meat from grill.

Care and Maintenance

To assure safe and proper maintenance, we recommend you follow these directions carefully.

Clean internal parts of the grill regularly as determined by the amount of use and foods cooked. The entire grill should be cleaned at least once a year.

In addition, keep the area around your grill or cart clear and free from combustible materials, gasoline, and other flammable vapors and liquids.

Cooking Grates

Use a solution equal parts detergent and hot water just as you would for any cooking equipment. A stiff brush may also be helpful in removing grime and food deposits.

Hood and Body

Wipe the inside hood and body with detergent and hot water. The external surfaces may be cleaned in the same fashion. Wipe all area dry before storing.

Storage

For your safety, make sure unit is cool and wood and charcoal embers completely extinguished before storing.

Drip Pan

The full width drip pan will collect grease from the main grill area. The pan should be cleaned after every use to avoid the possibility of a grease fire. Be sure to allow the drip pan to cool prior to cleaning. You may clean the drip pan with a solution of warm soapy water. Make sure to rinse thoroughly to avoid staining.

Care of Stainless Steel

Do NOT use wire wool pads, scrappers, harsh abrasive, scoring materials, bleaches, or harsh cleaners on your cart or grill, or allow salt and vinegar mixtures to remain in contact for a long period of time. This will cause scratching, scoring, rusting and pitting.

We recommend that you clean stainless steel components with a cleaner that is approved for stainless steel and only clean when the grill is cool and in indirect light. Never use steel wool.

Covering Your Cart or Grill

When not in use and after cooling, cover your cart or grill with our full length, zippered side canvas cover. (See your local Cal Flame dealer for details.) The cover will help protect your cart or grill from detrimental effects of weather and environmental pollutants. Never put a cover on a hot grill. Allow the grill to cool before covering.

After Use Care

The easiest way to clean the grill is immediately after cooking is completed and after turning off the flame.

- Scrub the grill rack with a brass bristle barbecue brush and hot soapy water.
- Wipe the grill with a damp soapy cloth and rinse with warm/hot, clean water. For more tenacious deposits, including oil, grease and water-borne deposits, use a multipurpose cream cleanser and apply with a soft, damp cloth.
- Dry with a soft, dry, clean towel if preferred.
- Be sure appliance is off and all parts are cool before handling or cleaning. This is to avoid damage and possible burns.
- To prevent staining or discoloration, clean appliance after each use.
- If a part is removed, be sure it is correctly replaced.

Warning

NEVER cover the entire cooking or grill surface with griddles or pans. Overheating will occur and the grill will not perform properly when heat is trapped below the cooking surface.

CAUTION: NEVER spray water on a hot unit.

Control Knobs

Wash, rinse and dry. Do not use abrasive cleaners as they may scratch the finish.

Turn on each element to be sure the knobs have been correctly replaced.

Control Area

Use mild cleaners, such as soapy water or mild liquid sprays. Wipe with sponge, damp cloth or paper towel. Do not scrub with steel wool pads or abrasive cleaners.

Stainless Steel Grids

To remove light soil, clean with soapy water or spray with cleaners. For easier cleanup:

1. Spray with a household cleanser
2. Cover with paper towels
3. Add small amount of hot water to keep paper towels moist
4. Cover and wait 15 minutes
5. Wipe clean

To remove moderate soil, scrub with a soft scrub cleanser or a plastic scrubber.

To remove stubborn soil, spray with an oven cleaner. Let soak overnight, wipe clean, rinse and dry.

Heating Elements

Never immerse in water. Most soil will burn off during use.

Stainless Steel Grates

Wash cool grates with detergent in hot water in the sink or wash them in the dishwasher. **DO NOT IMMERSE HOT GRILL GRATES IN WATER.** Be sure to remove all food residue before cooking on the grill again.

Remove stubborn soils with plastic mesh puff or pad. Use only those cleaning products which state they are recommended for use when cleaning nonstick surfaces.

If grates were washed in the dishwasher, season with oil prior to grilling.

Do not use metal brushes or abrasive scouring pads or other scrubbers intended to clean outdoor charcoal grills. These will remove the finish as well as scratch the grates. Do not clean in self-cleaning oven or use oven cleaners on the grates.

Electric Grill Wiring Diagram

Lloyds Material Supply (L.M.S.) offers the following limited warrants against defects in material and workmanship on Cal Flame barbecue products and components:

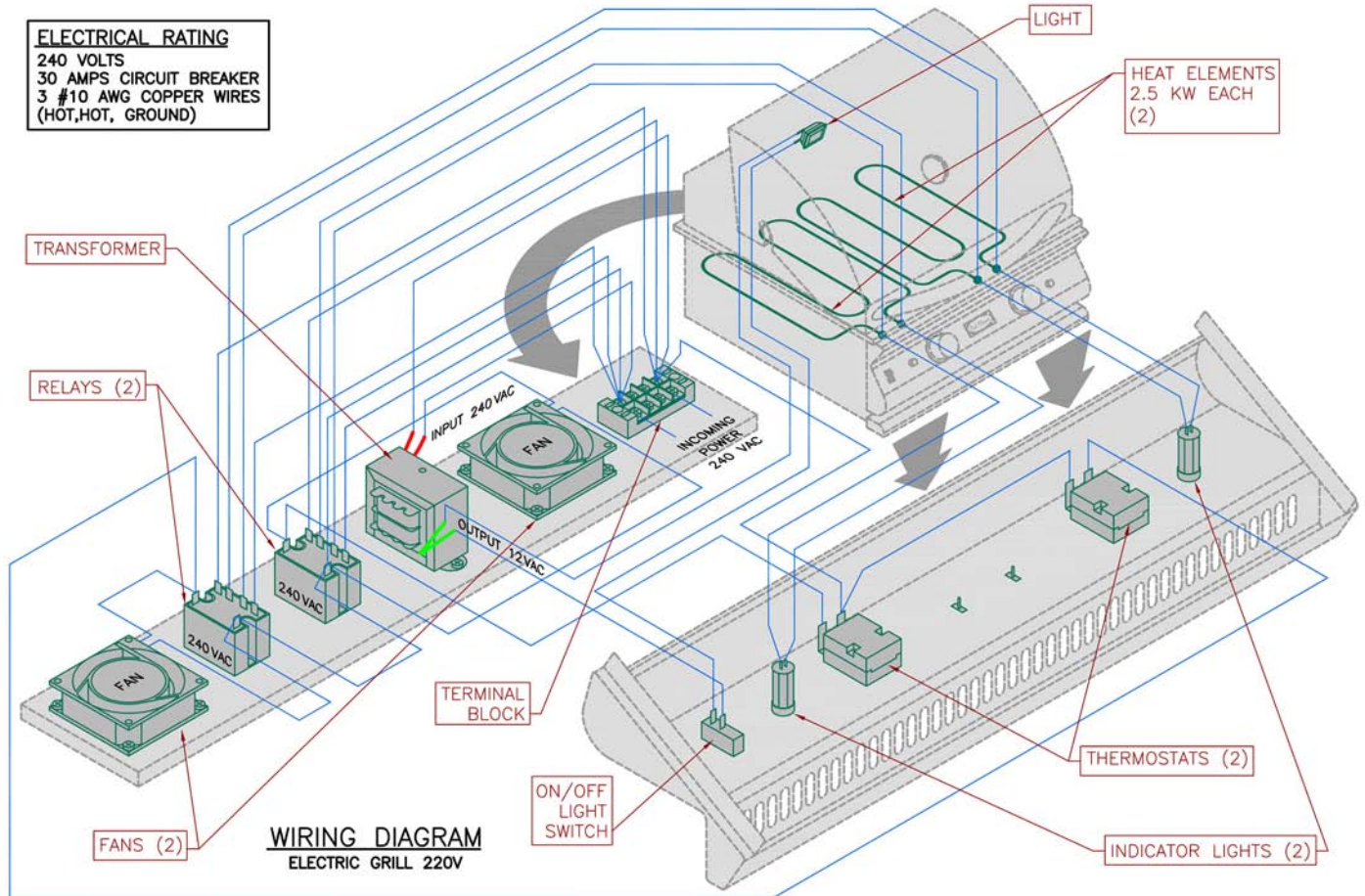

2008 WARRANTY

Lifetime Equipment Warranty

L.M.S. warrants against deterioration and corrosion

- Flame Tamers -- Stainless Steel
- Burners - Cast Stainless Steel
- Grates - Stainless Steel
- Griddle

Lifetime Structural Warranty

L.M.S. warrants the structural frame to maintain its integrity.

- Frame - Lightweight, Durable
- Galvanized Steel

Lifetime Component Warranty

- L.M.S. warrants against deterioration and corrosion
- Rotisserie - HD Stainless Steel
- Mountings - Stainless Steel
- Grill Lid and Body - Stainless Steel
- Flat Drop-In Body
- Charcoal Grill

Warranty

L.M.S. warrants the decorative finishes at time of delivery, including:

- Stucco
- Grout
- Brick
- Rock
- Tile
- Waterfall
- Granite
- Foot Rest
- Warming Drawer
- Umbrella
- Umbrella Lights

C.A.I warrants the cart's structural frame, all non-stainless steel fasteners, rotisserie motor, temperature gauge, plastic items, stainless steel drawers, doors, sinks, warming racks, ignitors, tube stainless steel burners, gas valves, food warmer, sear zone, infrared burners, cocktail center, modules, and ice chest for a period of one year.

Extent of Warranty

This 2008 Cal Flame Warranty is only valid on Cal Flame models delivered in the United States or Canada and extends through the selling dealer to the original purchaser at the original site of installation. This warranty becomes valid at time of purchase and ends either by specified time-frame listed above or upon owner transfer or relocation.

Manufacturer Warranty

All Cal Flame models are manufactured with the highest quality appliances and are warranted to be free from defects in material and workmanship at time of delivery. The appliance warranty is extended through the manufacturer of the product. These items include, but are not limited to, the following: Stereos, speakers, refrigerators, keg refrigerators, accessories, televisions, and DVD players.

Warranty Performance

In the event of a malfunction or defect covered under the terms of this warranty, a factory authorized service agent of L.M.S. will perform the necessary repairs. To obtain service, contact the selling dealer. In the event the consumer is unable to obtain satisfactory customer service from the selling dealer or service agent, written notification must be given to the L.M.S. Customer Relations Department within 10 days of the reported failure. There will be no charge for parts or labor on a covered item. However, the service agent may assess a reasonable travel or mileage charge per service call. If L.M.S. determines that repair of a covered item is not feasible, L.M.S. reserves the right to replace the defective merchandise with merchandise equal in value to the original purchase price. Warranty repair and / or replacement is the sole discretion of L.M.S. and this warranty does not cover costs therein, including but not limited to: freight, removal, re-installation, etc. This warrant is non-transferable and may not be extended beyond the above mentioned time frames under any circumstances, by any of L.M.S.'s representatives.

Warranty Limitations

This warranty is void if the barbecue grill, cart or island has been subject to negligence, alteration, misuse, repairs, dings, dents, scratches, or incorrect and / or prohibited applications, as specified in the Owner's Manual. Gas lines must be installed by a licensed plumber only or local gas company agent. Incorrect electrical installation by unlicensed electricians, service by non-L.M.S. authorized representatives, acts of God and other cases beyond the control of L.M.S. are not covered by this warranty. Please refer to the Owner's Manual for examples of exclusions and common acts invalidating this warranty. This limited warranty applies only to barbecue grills, carts, and islands used for personal, family, and outdoor household purposes. This warranty does not apply to labor charges on grills, replacement parts and hardware. This limitation is retroactive and applies to all grills and hardware manufactured from 2000 and hereafter.

Disclaimers

L.M.S. shall not be liable for loss of use of the barbecue grills, carts, islands or other incidental or consequential costs, expense or damages, which may include, but are not limited to, removal of permanent deck or other custom fixtures or the necessity for crane removal. Any implied warranty shall have duration equal of the applicable warranty stated above.

Natural stone: Rock, travertine, marble, granite, etc. may be characterized by dry seams, pits, chips, cracks, and fossils that are often filled with grout during installation. These are normal imperfections and are not considered defects.

Legal Remedies

This limited warranty gives you specific legal rights. You may have other rights, which may vary from state to state.

Customer Service

For customer service, contact the authorized selling dealer immediately. If you need additional information or assistance, please contact the L.M.S. Customer Relations Department at 1462 E. Ninth St., Pomona CA 91766 or call (800) 225-7727.



Warranty Information

See your Cal Flame barbecue dealer for a copy of the applicable warranty, details and any questions you may have regarding the warranty coverage on your barbecue.

Warranty Limitations

The Limited Warranty is void if the barbecue has been subject to negligence, alteration, misuse, abuse, repairs by non-L.M.S. authorized representatives, incorrect electrical installation, acts of God and any other cases beyond the control of L.M.S. Examples of common acts invalidating this warranty include but are not limited to:

- Scratches caused by normal use.
- Damage caused by extreme weather conditions (hot, cold, etc.)
- Damage caused by dirt, sand, and/or water damage.

- Damage caused by continued operation of the barbecue with either known or unknown problems.
- Damage caused by direct sunlight.
- Damage caused as a result of failure to follow the operating instructions as defined in this Owner's Manual.

This Limited Warranty applies only to barbecues normally used for personal, family, or household purposes.

This Limited Warranty specifically excludes commercial barbecues.

Warranty Exclusions

L.M.S. warrants the barbecues from defects in material and workmanship for a period of one year from the original date of purchase.

Barbecue stereo systems are delivered with their own manufacturer's warranty. For more information, see their warranties in the owner's information package that was delivered with your barbecue.

Don't forget to register your new product at www.calspas.com.

Locating the product serial number

The serial number of your Cal Flame grill is located on the back and is visible when the hood is down. You will need this number to properly register your grill or cart and activate coverage. Write this information in the space provided below.

Grill or cart model: _____

Grill or cart serial number: _____

Date purchased: _____

Date installed: _____

Cal Flame dealer's phone number: _____

Cal Flame dealer's address: _____