

Cal Flame[®]
A Division of Lloyds Material Supply, Inc.

2008 OWNER'S MANUAL

Barbecue Islands

Manufactured after January 14, 2008 • United States and Canada
© 2008 Lloyds Material Supply, Inc.



Due to our continuous improvement programs, all models, operation, and/or specifications are subject to change without prior notice.

www.calspas.com

Safety Instructions	1
Barbecue Island Assembly	3
Unit Attachment	3
Stucco and Tile Application	3
Rock / Stone Application	4
Granite Kit Instructions	5
Griddle and Griddle Storage	5
Installing New Access Doors	6
Light Switch Installation	6
G-3100 Canopy Assembly	7
Canopy Assembly and Wiring Instructions	7
Wiring Diagrams	10
Entertainment Options	12
Operating the CD Player	12
Playing a Movie	12
Using the Universal Remote Control	13
Programming the Universal Remote Control	14
Cleaning and Maintenance	15
About Natural Stone	15
Granite Top	15
Tile	16
Synthetic Panel	16
Warranty Information	17

WARNING

If the information in this manual is not followed exactly, a fire or explosion may result causing property damage, personal injury or loss of life.

Do not store or use gasoline or other flammable vapors and liquids in the vicinity of this or any other appliance.

Do not store an LP cylinder not connected for use in the vicinity of this or any other appliance. A fire resulting in serious injury or death may occur.

If you are installing a natural gas grill, you are responsible for ensuring that the natural gas line installed is safe to use. Lloyd's Material Supply (LMS) will not be held responsible for an improperly installed gas line.

DANGER

What To Do If You Smell Gas

- Shut off gas to the appliance.
- Extinguish any open flame.
- Open lid.
- If odor continues, keep away from the appliance and immediately call your gas supplier or your fire department.

CONTACT INFORMATION

For customer service, please contact your authorized dealer immediately. If you need additional information and/or assistance, please contact:

LMS Customer Service Department
1462 East Ninth Street
Pomona, CA 91766.

Toll Free: 1-800-CAL-SPAS
Fax: 1-909-629-3890

Safety Instructions

WARNING: Improper installation, adjustment, alteration, service or maintenance can cause injury or property damage. Read the installation, operating and maintenance instructions thoroughly before installing or servicing this equipment.

Placement and Location

- **Cal Flame™ grills and carts are designed for outdoor use only.**
- Never locate this appliance in an enclosed room, under a sealed overhead structure, or in any type of enclosed area such as a garage, shed, or breezeway. Keep clear of trees and shrubs.
- Do not place this grill under or near windows or vents that can be opened into your home.
- Cal Flame™ grills are not intended for installation in or on recreational vehicles or boats.
- Maintain sufficient distance as to not overheat any overhead combustible material such as a patio cover.
- The area surrounding your new grill should be kept clean and free from flammable liquids and other combustible materials such as mops, rags or brooms, as well as solvents, cleaning fluids, and gasoline.
- Do not use the grill, grill cabinet, or area surrounding the grill as a storage area for flammable or plastic items. Do not store the liquid propane (LP) cylinder in the vicinity of this or any other appliance when it is not being used.

Set-Up

- Before installing built in grills in enclosures, copy all product information such as model number, serial number and type of grill (e.g. natural gas or LP) and store information in a safe place. This information is located on a plate located behind the grill and is visible when the hood is lowered or on the right side of the chassis. There is an area on the back cover of this manual where you can write down this information.
- We recommend that a licensed contractor install your Cal Flame™ grill. Installation must conform to local codes, or in the absence of local codes, with either the *National Fuel Gas Code, ANSI Z223.1 / NFPA54, Natural Gas and Propane Installation Code, CSA B149.1, or Propane Storage and Handling Code, B149.2*, as applicable.

- Your Cal Flame™ grill or cart must be plugged into a permanent, grounded 110V outlet with a dedicated 15A GFCI breaker in accordance with local codes or the *National Electrical Code, ANSI / NFPA 70*, or the *Canadian Electrical Code, CSA C22.1*.
- Do not use an extension cord to supply power to your Cal Flame™ grill or cart. Such use may result in fire, electrical shock or other personal injury. Do not install a fuse in the neutral or ground circuit. A fuse in the neutral or ground circuit may result in an electrical shock hazard. Do not ground this appliance to a gas supply pipe or hot water pipe. Keep any electrical supply cords and the fuel supply hose away from any heated surfaces.
- To prevent fire and smoke damage, remove all packaging material before operating grill.
- Before you start cooking, clean the entire grill thoroughly with hot, soapy water. This is necessary to remove residual solvents, oil and grease used in the manufacturing process. The grates should also be thoroughly cleaned in the same manner.

Operation

- In the event that a burner goes out, turn burner knobs to the full OFF position, fully open the grill hood and let it air out. Do not attempt to use the grill until the gas has had time to dissipate.
- Never use the grill if the drip pan is not properly installed. Drip pan should be pushed all the way to the rack located just under the grill. Fire or explosion can result from an improperly installed drip pan.
- Keep all electrical supply cords and the rotisserie motor cord away from the heated areas of the grill.
- Never use the grill or side burner in windy conditions. If used in a consistently windy area a windbreak will be required. Always adhere to the specified clearances listed in this manual.
- Never line the grill or side burners with aluminum foil.
- When the unit is not in use, be sure to turn off the gas at the LP tank.

Safety Instructions

- Do not install or operate your grill unit in such a manner that the cross ventilation openings are blocked. Fresh air must be able to pass through installed vents to safeguard against residual gas accumulation. Failure to allow proper ventilation may cause fire or explosion.
- When handling LP gas line and connectors, do not allow them to come in contact with any metal surfaces of the cart or cabinet. Do not drop LP connectors.
- Gas sources to the grill and side burners must be regulated. Do not operate grill or side burners if regulators have been removed, fire or explosion can occur.
- Never leave the grill and side burners unattended when in use. When using pots and pans, boil-overs will cause smoking and greasy boil-overs may ignite.
- Always use the proper size pan. Select utensils with flat bottoms large enough to cover the burner. The use of under-sized utensils exposes the sides of the utensils to direct contact with a portion of the flame. This can scorch utensils and hamper cleanup. Excessive flames on large stainless steel pots can result in permanent discoloration. For best results, we recommend commercial quality aluminum pans and utensils.
- Always position handles of utensils so they do not extend over adjacent work areas or cooking areas. This reduces the risk of burns, ignition of flammable materials, and spillage due to accidental contact with the utensils.
- Do not use water on grease fires. Never pick up a flaming pan. Turn the appliance off and smother the flaming pan with a tight-fitting lid, a cookie sheet or a flat tray. For flaming grease outside of the pan, smother it with baking soda or use a dry chemical or foam-type fire extinguisher.
- Never allow clothing, pot holders or other flammable materials come in contact with or be close to any grate, burner or hot surface until it has fully cooled. Never wear loose fitting or hanging garments while using your grill. Fabric may ignite and result in personal injury.
- When using the grill, do not touch the grill rack, burner grate, or immediate surroundings as these areas become extremely hot and can cause burns.
- Only use dry pot holders and do not use a towel or other bulky cloth in place of pot holders. Moist or

damp pot holders used on hot surfaces can cause burns.

- Do not heat any unopened glass or metal container of food on the grill. Pressure may build up and cause the container to burst, possibly resulting in serious personal injury or damage to the grill.
- Do not reach over your grill or any other surfaces when hot or in use.

Maintenance and Repair

- Spiders and other insects can nest in the burners of the grill and block the gas and airflow to the burner ports. This creates a dangerous condition that can result in a fire behind the valve panel. Inspect and clean the burners periodically and follow the guidelines in the Cleaning and Maintenance section of this manual.
- Unless specifically recommended in this manual, do not repair or replace any part of the grill. A qualified technician should perform all service. Any repairs made by a non-LMS approved dealer technician will void your warranty.

Storage

- When your gas grill is not in use, turn off the gas at the supply cylinder.
- Storage of a grill or cart indoors is permissible only if the supply cylinder is disconnected and removed.

Precautions Regarding Children

- Never leave children unattended in the area where the grill is being used.
- Do not store items of interest to children around or below the grill or cart.
- Never allow children to sit or stand on any part of the grill or cart.

Barbecue Island Assembly

Unit Attachment

1. Place the island sections together on the ground. Make sure the ground where the barbecue is placed is as level as possible for best alignment.

NOTE: If the ground is not level, use shims to level out the island sections. This needs to be done before you install the bolts.



2. Connect the speakers, lights, and main power cables before sliding the sections together.
3. Insert the bolts through the pre-drilled holes from the inside of the barbecue island (total of four bolts on each side).



3. Tighten all bolts using a 9/16" wrench.

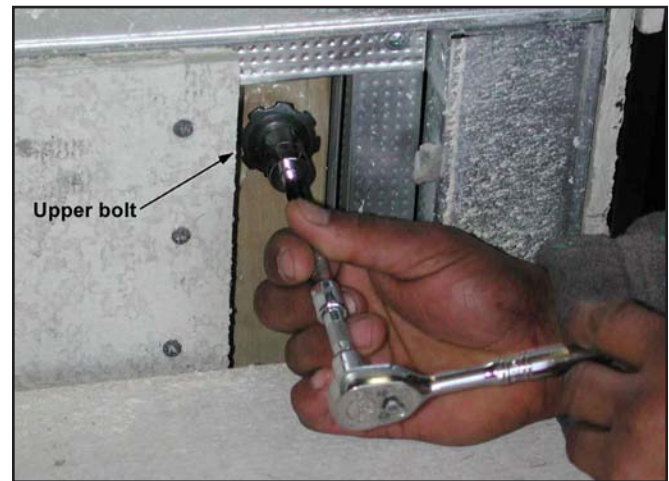

Stucco and Tile Application

1. Prepare and fill the gap or seam line with speed set.
2. Using your fingertips, push and flatten out the speed set into the seam line.

NOTE: Allow the speed set to dry before proceeding with the next step.

3. Using a small brush or hopper gun, apply stucco to the seam line.
4. Mix grout with water in a container.
5. Fill the tile seam line with grout using a small spatula or your finger.
6. Clean the grout with a damp rag.
7. Let the grout and stucco dry for at least three hours.

Assembly

Rock / Stone Application

1. Place the island sections together on the ground.
2. Make sure the ground where the barbecue is placed is as level as possible for best alignment.

NOTE: If the ground is not level, use shims to level out the island sections. This needs to be done before you place the bolts.

3. Connect the speakers, lights, and main power cables before sliding the sections together.
4. Insert the bolts through the pre-drilled holes from the inside of the barbecue island (total of four bolts on each side). Tighten all bolts using a 9/16" wrench.
5. Prepare mortar in a container.



6. Apply mortar to the gaps left open between the island assembly (front and back).
7. Let it dry for 15 to 30 minutes and brush the area where the mortar mix was applied.
8. Prepare grout in a second container.
9. Fill the tile seam with grout using a small spatula or your finger.
10. Clean the grout with a damp rag.
11. Let the grout and mortar dry for at least three hours.

Granite Kit Instructions

Granite kits come in the following colors. Each contains various tinting colors as listed below:

Sapphire Brown	Giallo Veneziano
Black	Red-Brown
White	Yellow
Blue	Black
Brown	White

New Venetian Gold	Uba Tuba (Labrador)
White	Black
Yellow	White
Blue	Green



1. Pour a small amount of epoxy resin and a small drop of each tint color on a piece of a cardboard.

NOTE: Refer to the granite tint color reference chart

2. Apply a small amount of the first tint color to the epoxy resin using a mixing stick and mix well.
3. Apply a small amount of the second tint color to the epoxy resin and mix well.
4. Apply a small amount of the next tint colors, one at a time to the epoxy resin and mix well.
5. Compare color of mixed epoxy resin with the color of the counter top.
6. If the colors do not match, add small amounts of tint color (one at a time) and mix until the resin mixture matches the color of the granite top.
7. Add a small amount of hardener to the matching resin mixture and mix well.
8. Quickly fill one portion of the seam line with the epoxy mixture. Remove the excess epoxy material from the seam line using a razor blade.
9. Let the epoxy material cure for five minutes.
10. Pour a small amount of epoxy and hardener separately on a piece of cardboard.
11. Mix the epoxy material well with the hardener.
12. Quickly apply the epoxy mixture to the seam line. Remove the excess epoxy material from the seam line using a razor blade.
13. Let the epoxy material cure for five minutes.
14. Repeat the previous steps until all the seam line is filled with epoxy mixture.
15. Clean the surface of the seam line with acetone.

Griddle and Griddle Storage

Similar to installing a drawer, you need to have a cutout on your barbecue island as shown below. Align the enclosure as shown, opening facing out. Make sure the enclosure is aligned horizontally. Tighten the mounting screws on both side of the enclosure to lock the enclosure in place. Slide the griddle into the enclosure to test the installation.

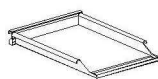

GRIDDLE

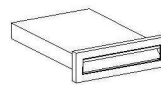

ENCLOSURE

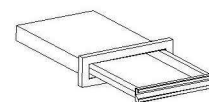

GRIDDLE AND ENCLOSURE

Assembly

Installing New Access Doors

1. Provide a cut out and a door jamb with inside dimensions as follows:

16 1/4" X 19 " for a single door

28 1/4" x 19 3/8" for double doors

2. Secure the steel frame with 16 #10 x 1" truss head phillips screws.
3. Attach doors to frame.
4. Adjust doors as follows:

- a. For height adjustment, loosen the two screws attached to each mounting plate.
- b. Snap off hinge and secure mounting plate with #6 X 1" flat phillips screws.
- c. For side adjustment, turn the screws to increase or decrease door overlay.
- d. For depth adjustment, loosen screws, adjust the door to the desired position and retighten the screws.

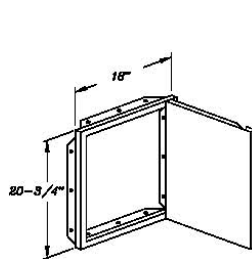

SINGLE ACCESS DOOR
FRONT DIMENSIONS

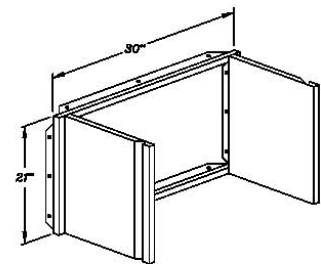

DOUBLE ACCESS DOOR
FRONT DIMENSIONS

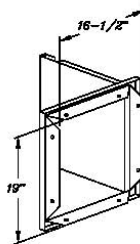

SINGLE ACCESS DOOR
REAR CUT OUT DIMENSIONS

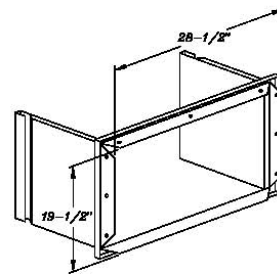

DOUBLE ACCESS DOOR
REAR CUT OUT DIMENSIONS

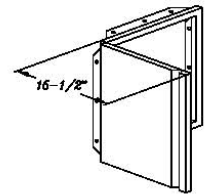

CUT OUT DIMENSIONS

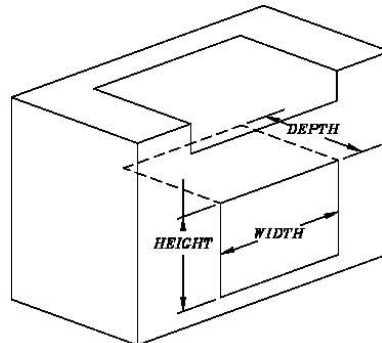

SINGLE DOOR	
WIDTH	16-1/2"
HEIGHT	19"
DEPTH	2-1/2"
DOUBLE DOOR	
WIDTH	28-1/2"
HEIGHT	19-1/2"
DEPTH	2-1/2"

Light Switch Installation

If you have the hardware interior island option, you will need to install the light kit. The kit consists of a 12-volt light, a wiring harness and a microswitch and bracketry.

The microswitch mounts to the bracket with a supplied set of screws and nuts.

Once you mount the the switch bracketry, choose a location for the light. The light can be mounted anywhere in the island that provides you with the light you need for your internal storage area.

The 12-volt light portion of your kit will have the necessary mounting hardware. Be sure to keep the light within the range of the provided wire harness and the hot portions of the grill.

G-3100 Canopy Assembly

Canopy Assembly and Wiring Instructions

Step 1: Install the posts

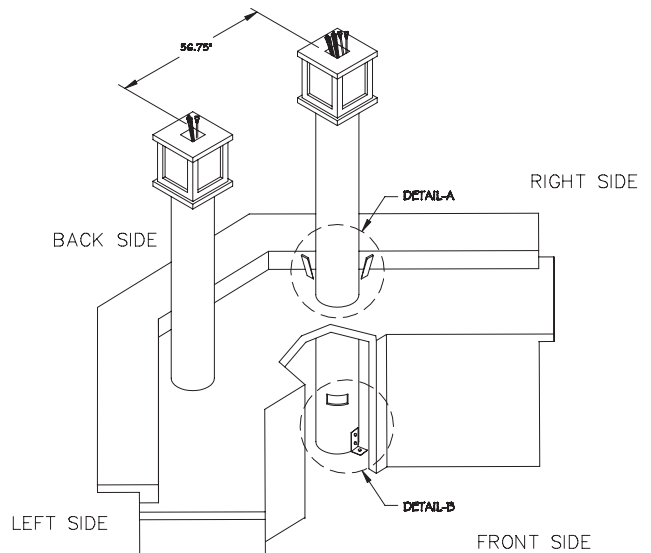
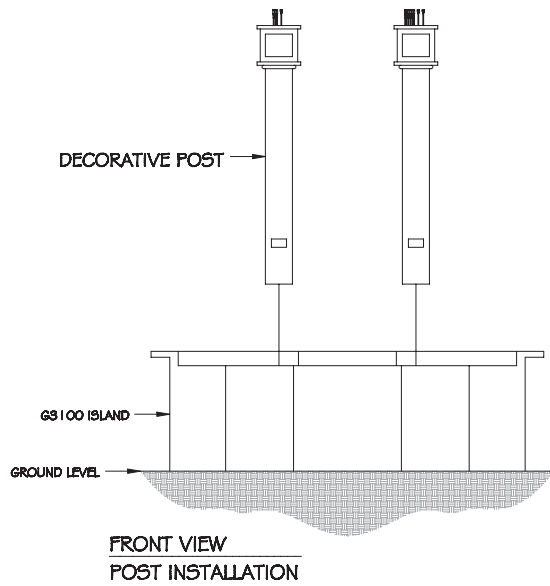
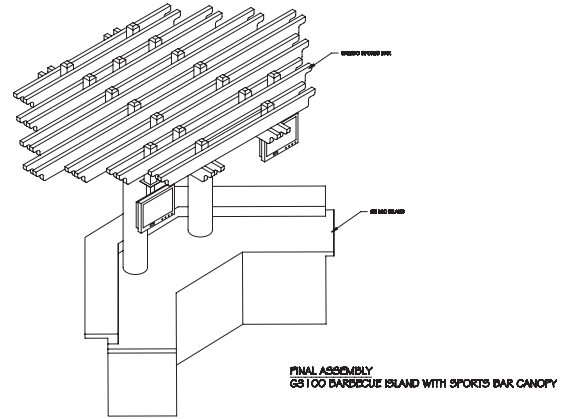

**ISOMETRIC VIEW
POST INSTALLATION**
SET POST INTO THE PROPER ANCHORING APPARATUS THRU THE TWO HOLES IN THE ISLAND COUNTER TOP. MAKE SURE THE TWO POSTS ARE INSTALLED LEVEL AND PLUMB.

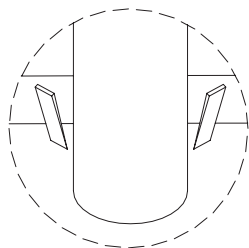

**DETAIL-A
SHIM POST**
MAKE SURE THE POSTS ARE INSTALLED LEVEL AND PLUMB USING SHIMS.

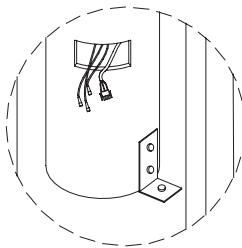

**DETAIL-B
"L" BRACKET CONNECTION**
USE "L" BRACKET TO MOUNT POST TO THE FLOOR BOARD.

G-3100 Sports Bar Canopy Assembly

Step 2: Assembling and wiring the canopy rafters

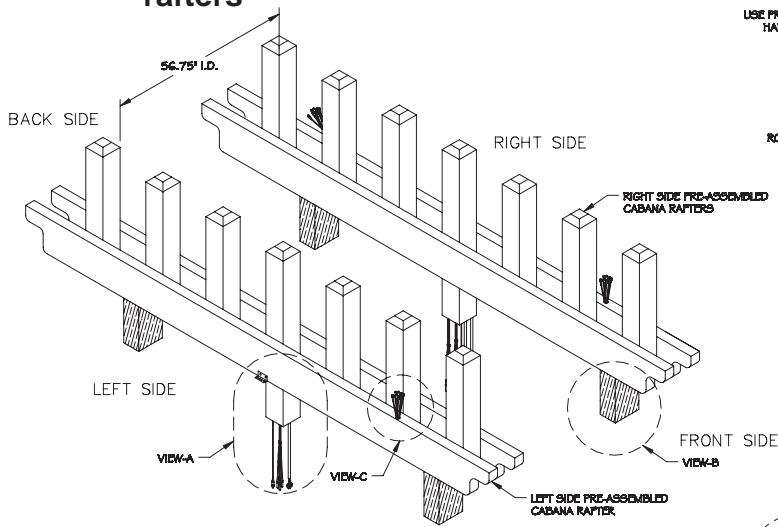

**ISOMETRIC VIEW
PRE-ASSEMBLED CABANA RAFTERS**

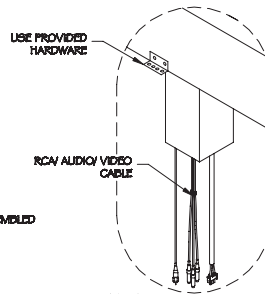

VIEW-A
RCA/ Audio/ Video/ Power 120/ ANT.
RCA/ AUDIO/ VIDEO/ POWER 120/ ANT.
FOR ALL THREE TELEVISIONS ARE PRE-WIRED.
(TWO PLACES)

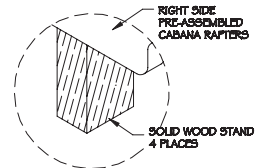

VIEW-B
SOLID WOOD STANDS
USE SOLID WOOD STANDS TO
STABILIZE AND SUPPORT
PRE-ASSEMBLED CABANA RAFTERS
(FOUR PLACES.)

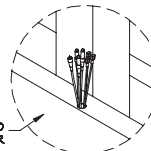

VIEW-C
RCA/ Audio/ Video/ ANT.
RCA/ AUDIO/ VIDEO FOR ALL THREE
TELEVISIONS ARE PRE-WIRED. (3 PLACES)

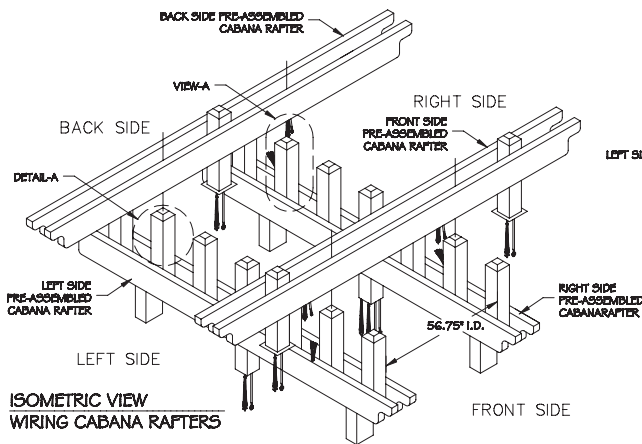

**ISOMETRIC VIEW
WIRING CABANA RAFTERS**

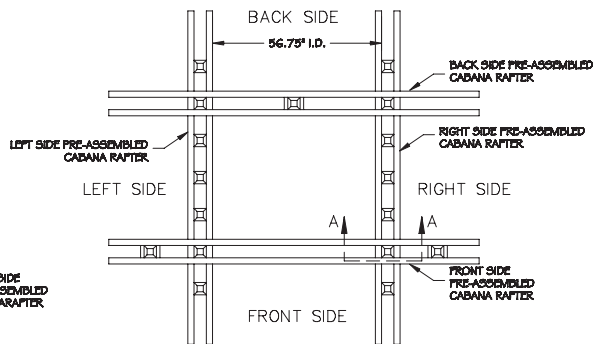

**TOP VIEW
WIRING CABANA RAFTERS**

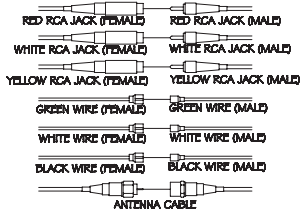

VIEW-A
RCA/ Audio/ Video/ Power 120/ ANT
MAKE CONNECTIONS AS SHOWN TO THE
RCA/ AUDIO/ VIDEO/ POWER 120 WIRES/ ANT.
(3 PLACES)

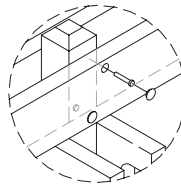

DETAIL-A
PRE-ASSEMBLED RAFTER TO POST
PRE-DRILL $\frac{5}{8}$ " HOLE IN APPROXIMATE
LOCATION. USE $\frac{3}{8}$ " HARDWARE PROVIDED
TO ATTACH BEAMS TO STUB THEN USE CAP
TO COVER $\frac{5}{8}$ " HOLE AS SHOWN.

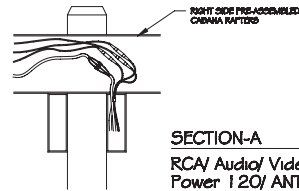

SECTION-A
RCA/ Audio/ Video/
Power 120/ ANT
AFTER MAKING CONNECTION AS
SHOWN IN VIEW-A FOR THE
RCA/ AUDIO/ VIDEO/ POWER 120
ALL WIRES AND CABLES SHOULD BE
CAREFULLY PLACED INSIDE OF BEAM
AS SHOWN.

G-3100 Sports Bar Canopy Assembly

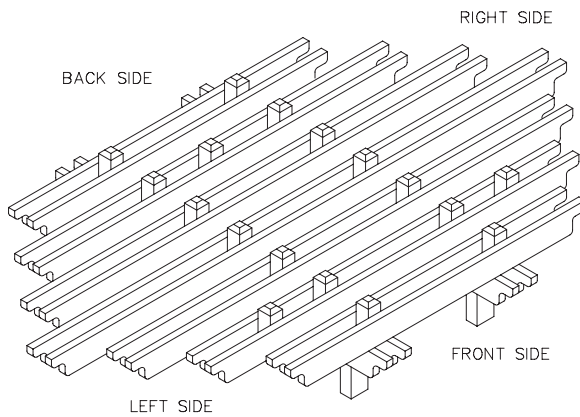

ISOMETRIC VIEW
FINALE ASSEMBLY CABANA

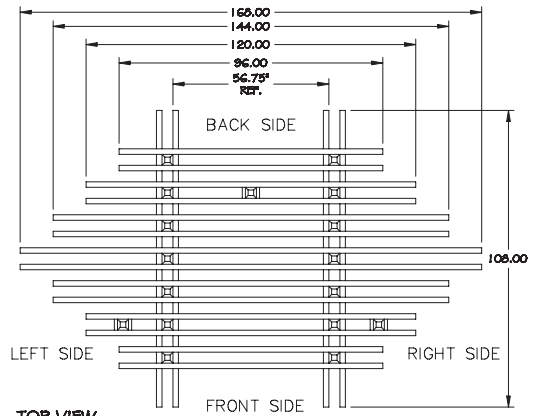

TOP VIEW
FINALE ASSEMBLY CABANA
ATTACH THE REST OF THE BEAMS
ACCORDING TO THIS TOP VIEW.

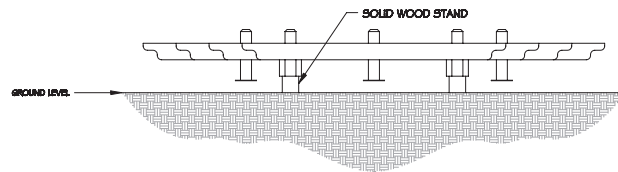

SIDE VIEW
FINALE ASSEMBLY CABANA

Step 3: Placing the canopy on the posts

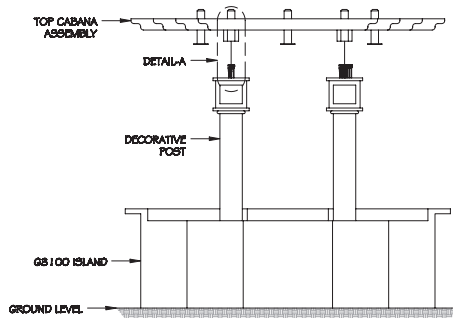

FRONT VIEW
POST INSTALLATION

YOU WILL NEED HELP TO CARRY THE TOP CABANA ASSEMBLY TO THE TOP OF THE ISLAND POST. AFTER THE TOP CABANA ASSEMBLY HAS BEEN MOUNTED SEE DETAIL-A FOR ATTACHMENT INSTRUCTIONS.

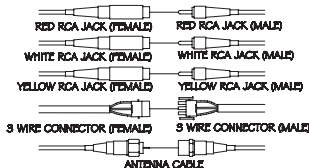

DETAIL-B
RCA/ Audio/ Video/ Power 120/ ANT.
MAKE CONNECTIONS AS SHOWN TO THE
RCA/ AUDIO/ VIDEO/ POWER 120 WIRES/ ANT.
(3 PLACES)

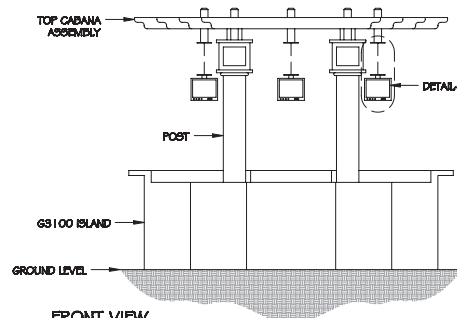

FRONT VIEW
T.V. INSTALLATION
SEE DETAIL-A FOR DETAILS
ON T.V. CONNECTION.

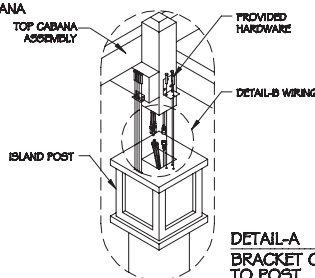

DETAIL-A
BRACKET CONNECTIONS
TO POST
ATTACH TOP CABANA ASSEMBLY TO
POST WITH PROVIDED HARDWARE
AS SHOWN.
(2 PLACES)

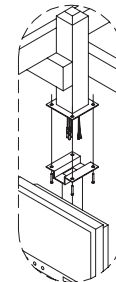

DETAIL-C
T.V. TO CABANA CONNECTION
ATTACH T.V. TO THE TOP CABANA ASSEMBLY
USING THE HARDWARE PROVIDED.
(3 PLACES)

G-3100 Sports Bar Canopy Assembly

Wiring Diagrams

Power supply wiring diagram

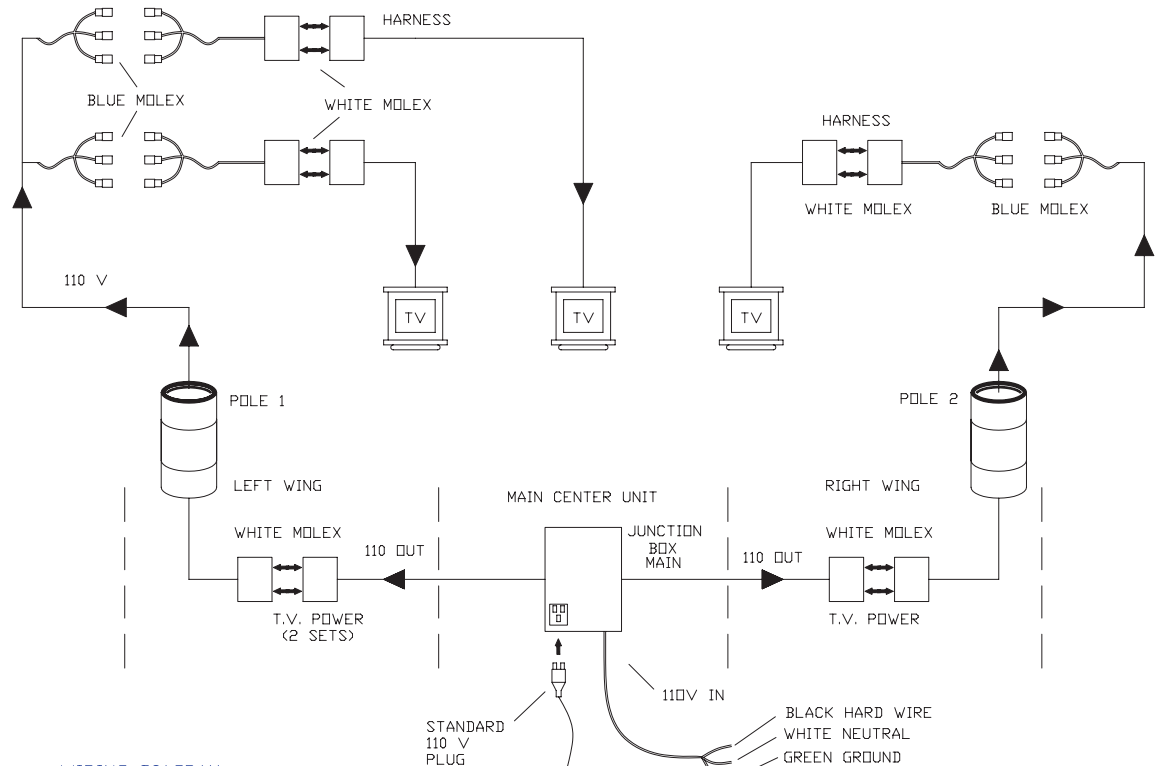

Audiovisual system wiring diagram

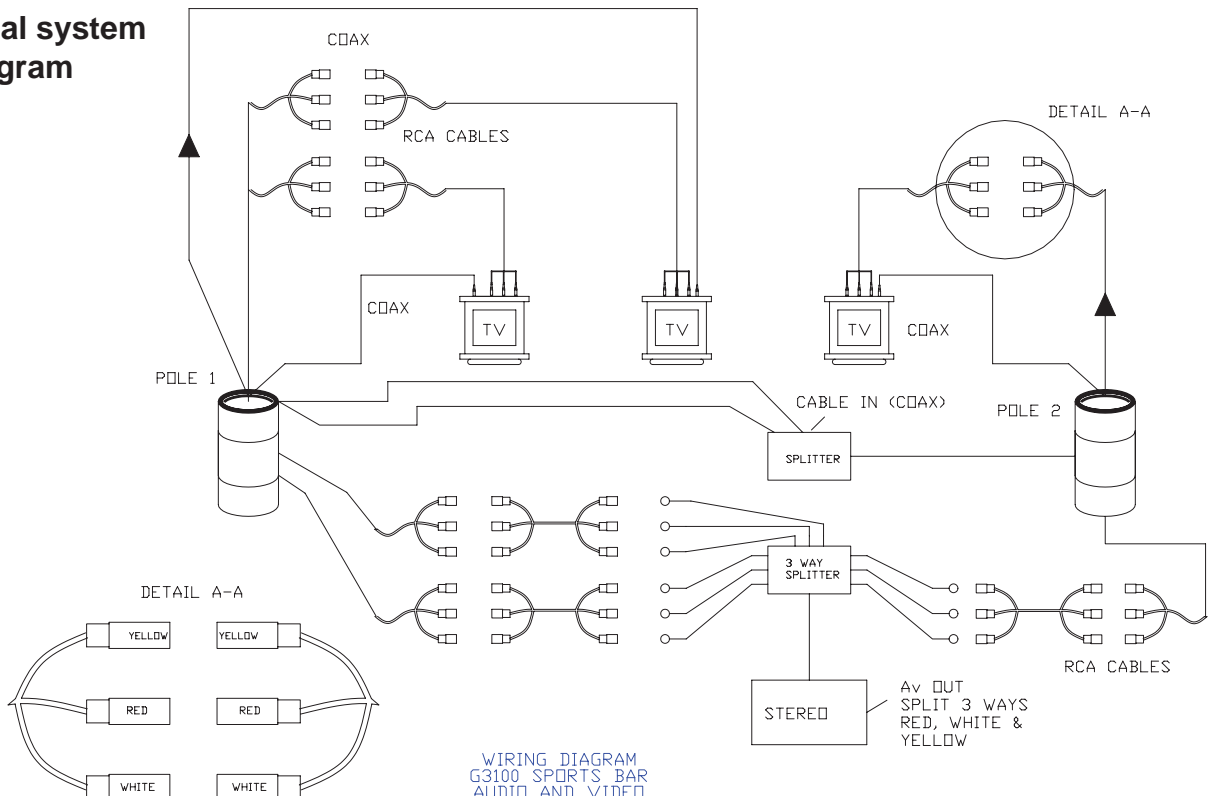

DVD / stereo system wiring diagram

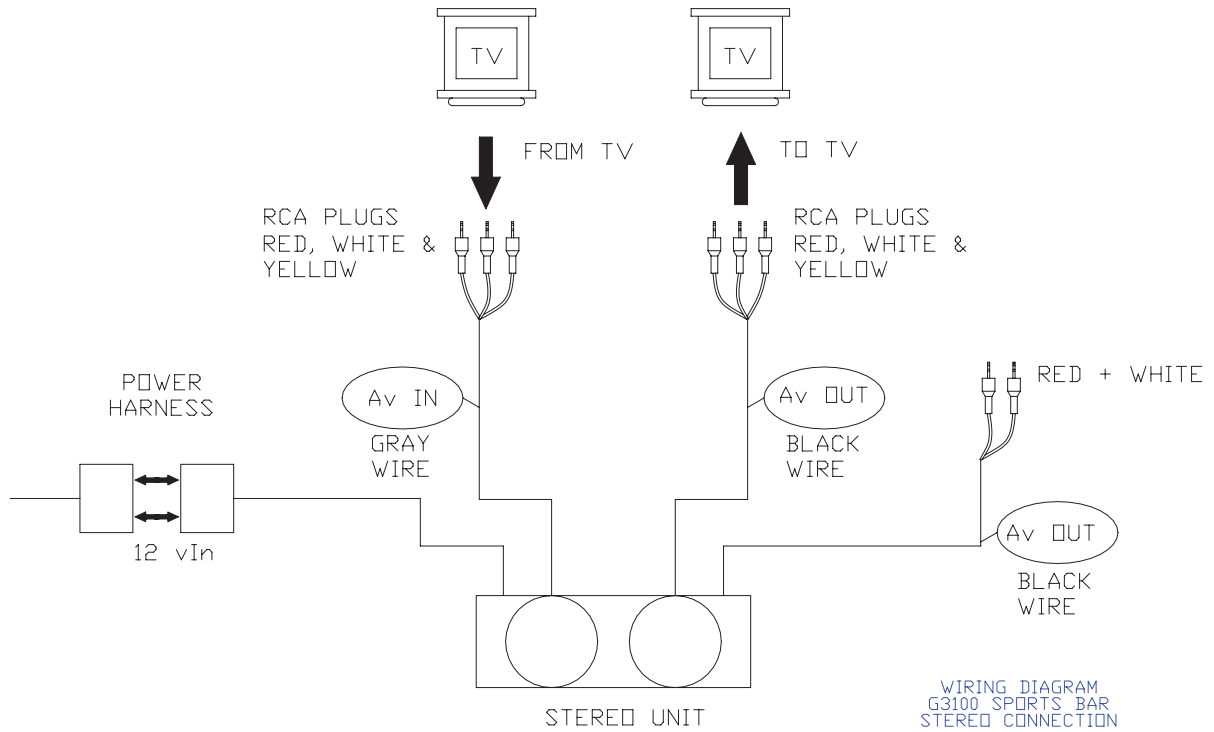

Entertainment Options

Some barbecue islands may be equipped with audio/visual entertainment options. Several options are available and include marine grade CD players and DVD players. Two different TV monitors are also available. Each Cal Flame™ unit equipped with an audio/visual system is delivered with the manufacturer's operating instructions. We strongly recommend that you read these instructions prior to operating the unit.

The instructions contained in this manual describe only basic functions. See the manufacturer's operating instructions for other features and functions. These instructions are delivered with the Cal Flame™ owner's manual in a clear plastic bag.

Observe the following precautions for your entertainment system:

- Make sure that hands and CDs / DVDs are dry before coming in contact with this or any electronic option.
- Always close the CD / DVD protection door.
- Do not place wet CD's or DVD's into this unit at any time.
- Water damage is not covered by Cal Spas or the manufacturer's warranty.

Although the marine grade entertainment system is encased in a plastic housing with weather seals, the system is water resistant and NOT waterproof. You must take every precaution to keep this system dry! Water damage is not covered by Cal Spas or the manufacturer's warranty.

WARNING! Although the TV monitor is water-resistant, make sure that hands are dry before coming in contact with this or any electronic option. **DO NOT SPLASH WATER ON THE TV MONITOR!**

Operating the CD Player

The manufacturer's operating instructions are delivered with your barbecue island. We strongly recommend that you read these instructions prior to operating this unit. Press the POWER button on the unit or the remote control to turn the system on. The system automatically starts in the mode it was in when it was last shut off.

Listening to the Radio

1. Press the MODE button to switch to the radio mode.

2. Press the left and right arrows located at the far right of the panel to tune the radio to a station.

Inserting a Disk

For the Sony CDX-HS70MW and Aeware systems:

1. Press the OPEN button on the unit. The faceplate will gently lower and expose the disk drive.
2. Insert a disk in the disk drive.
3. Flip up the faceplate.

For the Sony CDX-GT10M system, simply insert a disk into the slot in the faceplate.

Playing a CD

You can play CDs with any of the media systems (Sony or Aeware).

1. Insert a disc in the disc drive as described above. The player will identify the type of disc and begin playing it.
2. Use either the remote control or the buttons on the faceplate to start and stop the player and to jump to selections.
3. To remove the disc, press the EJECT button.

Playing a Movie

1. Press the OPT.1 button to raise the TV.
2. Turn on the TV using the universal remote control.
3. Insert a disk in the DVD player as described above. The player will identify the type of disk and begin playing it. Either the DVD menu will appear on the TV screen or the movie will begin playing automatically.
4. Use the remote control to navigate the DVD menu using the fast forward and fast reverse buttons located at the lower part of the universal remote.
5. To remove the disk, press the OPEN button on the DVD player. The faceplate will gently open. Press the small EJECT button located to the left of the disk drive slot.

Using the Universal Remote Control

Everything you want to do with your entertainment system can be controlled with the universal remote. All of the commands are organized into six areas.

Device selection buttons	Selects among six devices: TV, VCR, CD player, DVD player, stereo receiver, and satellite
Navigation and menu selection buttons	Selects among set-up, menu, and channel guide functions
Channel and volume control	Adjusts the volume up and down and
Spa controls	Selects among eight functions specific to the spa, such as blower, pumps and light
Keypad	Used to enter TV channels
CD and DVD controls	Use to control a CD or DVD player

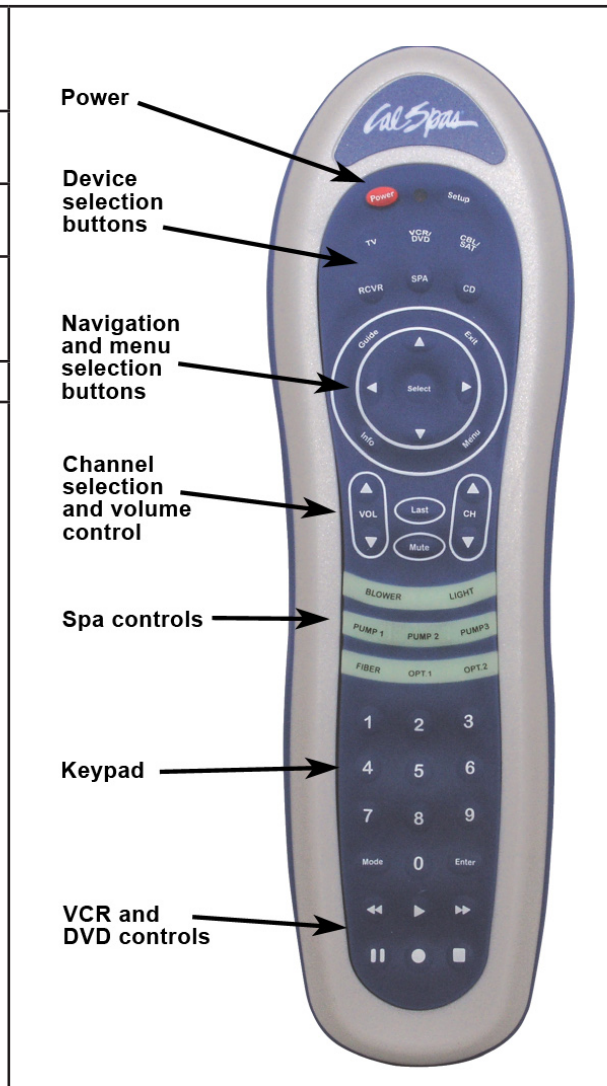

Entertainment Options

Programming the Universal Remote Control

The Cal Spas universal remote has been pre-programmed to function with the entertainment system the spa has been configured with. However, in case you need to reprogram the remote, use the device list below for the programming code.

1. Turn on the device (TV, CD player, DVD player) with the manufacturer's remote control.
2. Press the button on the remote for the device you want to program (TV, CD, DVD, etc.)
3. Press and hold the SETUP button until the LED blinks twice.
4. Enter the device code. If you perform this procedure correctly, the LED will blink twice. If not, repeat steps 2 and 3.

Device Manufacturer	Device Type	Code
Samsung 42" plasma	TV	1312
River Park 20"	TV	1530
Aeware	DVD	1866
Sony CDX-GT10M	CD	
Sony CDX-HS70MW	CD	

Waterfalls

Although the canopy waterfall and the barbecue island waterfall have different appearances and locations, they operation in the same manner.

- Fill the tank with water and make sure the water level is above the submersible pump.
- Ensure the pump is connected to 110V GFCI outlet.
- Make sure that there is no debris in the filler pan for the waterfall.
- Maintain a consistent water level, as dry pumping will burn out the pump motor.
- Turn on the waterfall by flipping up the switch to the ON position.

LED Lights

The switch for the LED lights is located in a covered utility box on the side of the barbecue island. Flip it up to turn all the lights on.



Cleaning and Maintenance

About Natural Stone

A natural characteristic of granite and marble is its inherent lack of uniformity. Because it is a completely natural material, it can have a great deal of variation in color, shade, finish, tint, hardness, strength, and so on.

Any time you use natural stone, you can always expect differences from one tile to the next. You will frequently see dry seams, pit or fossils. These areas are often filled in at the factory. Over time through normal use, the fill may work its way out.

Even though stone tile is a natural product, it nevertheless can be affected by extremes in weather. Both marble and granite are decorative and durable, but they have different compositions and wear differently in the elements.

We recommend barbecue island owners keep their island covered if they are concerned about damage from constant exposure to weather. This is particularly true in areas where there is snow, ice, or very hot weather.

Stone is porous, especially marble, and often has natural fissures in the surface. Constant exposure to extreme heat or cold can cause these natural features to expand and eventually crack.

Although the stone has been properly finished and is suitable for use in an outdoor environment, Cal Spas does not apply a weather sealant to our countertops. We never wish to second-guess how our customers want to use their barbecues or the locale they will use them in, so we leave the choice of applying a weather sealant entirely up to owners.

We do not recommend any specific brand or manufacturer, although there are literally hundreds of excellent products on the market customers may choose from.

In addition to maintaining the stone tile surfaces, barbecue island owners need to know that the grout between the tile, while it is durable, can also be affected by both extremes in weather and by normal use. Grout is much easier to repair than stone tile and gaps between the tile can cause water to seep into the barbecue island and cause damage to the interior.

In those instances where natural cracks occur, we recommend having an experienced tile worker filling them with a material of a complementary color. After the filler sets and is sanded smooth, apply a weather sealant to help prevent further cracking.

For the benefits it yields, we cannot stress the importance of regular preventive maintenance. It is inexpensive

and will help a barbecue island remain attractive and in excellent condition for years.

Granite Top

Clean stone surfaces with a few drops of neutral cleaner, stone soap (available from Monticello Granite) or a mild liquid dishwashing detergent and warm water.

Use a clean rag for best results.

Too much cleaner or soap may leave a film and cause streaks.

Do not use products that contain lemon, vinegar or other acids on the granite the high acid content may etch the surface.

Rinse the surface thoroughly after washing with the soap solution and dry with a soft cloth.

Change the rinse water frequently.

Do not use scouring powders or creams; these products contain abrasives that may scratch the surface.

Do's

- Dust surfaces frequently
- Clean surfaces with mild detergent or stone soap
- Thoroughly rinse and dry the surface after washing
- Blot up spills immediately

Don'ts

- Don't use vinegar, lemon juice or other cleaners containing acids.
- Don't use cleaners that contain acid such as bathroom cleaners, grout cleaners or tub & tile cleaners.
- Don't use abrasive cleaners such as dry cleansers or soft cleansers.
- Don't mix bleach and ammonia; this combination creates a toxic and lethal gas.

Scratches and Chips

Small scratches are visible because they are lighter in color than the surrounding areas. Making them darker will hide them. On dark stones, we have had good success using permanent black magic markers. Do not use them on lighter stones. Apply the marker to the scratch, let it dry, and then rub it off the surrounding area.

Both marble and granite may chip when subjected to a sudden impact. If you have a large chip, try to find the loose pieces. They can often be epoxied back into place.

Cleaning and Maintenance

The chip can also be filled with colored epoxy to match the surrounding stone. Repairing this kind of damage should be left to other knowledgeable professionals.

Tile

If spillage occurs, then clean up as soon as possible.

Care

- Protect against chipping by using a cutting board.
- Protect against scratches, especially on natural stone tiles.
- Avoid hard blows that can chip the tile.
- Standing water or other liquids can deteriorate tile and grout, and should always be removed.

Cleaning

Wash with detergent solution, and rinse. To clean dingy grout, occasionally apply a solution of chlorine bleach and water to stand not more than 5 minutes; rinse thoroughly and wipe dry. General-purpose household cleaners may also be used if label says can be used on ceramic tile; follow directions exactly. NEVER use scouring powders or other abrasives as they will scratch the finish.

Stain Removal Guide

Stain	Removal Agent
Grease and fats	Soda and water or commercial spot lifter
Inks and colored dyes	Household bleach
Blood	Hydrogen Peroxide or household bleach
Coffee, tea, food, fruit, lipstick, juices	Neutral cleaner in hot water followed by hydrogen peroxide or household bleach

Caution: Vinegar may damage some tile.

DO's and DON'Ts of Tile Care

- Do test scouring pads in a small area first.
- Do use a silicone sealer on grout joints if continuous staining is a problem.
- Do read and follow label directions for all cleaners.
- Do keep this information and refer to it when necessary.
- Do not combine ammonia and household bleaches.

- Do not use harsh cleaning agents (such as steel wool pads) which can scratch or damage the surface of your tile.
- Do not place sharp object on tile surface.
- Never use wax to clean tile surface.

Care and Maintenance of Tile Grout

Grout may present a special cleaning problem because it is susceptible to many staining agents.

Apply a silicone sealer to grout joints several times a year for maximum protection.

In addition to keeping the grout clean, be sure to keep grout joints in good repair. Scrape out loose, cracked or powdery joints and refill with a good grout.

One common grouting trouble spot is the joint between the tub and the wall in your bathroom. As the house or tub settles, the grout may crack and crumble. It's relatively simple to remedy. Remove the old grout with a sharp pointed tool, watching out that you don't scratch tile or tub. Then dry the joint thoroughly and fill with a flexible tub or wall caulking compound, such as silicone rubber caulking.

Synthetic Panel

Do's

- Do dust surfaces frequently.
- Do clean synthetic panels with water and mild detergent.

Don'ts

- Don't use any cleaning chemical to clean or wash synthetic panels.
- Don't use vinegar, lemon juice or other cleaners containing acids.
- Don't use cleaners that contain acid such as bathroom cleaners.
- Don't mix bleach and ammonia; this combination creates a toxic and lethal gas.

2008 WARRANTY

Lloyds Material Supply (LMS) offers the following limited warrants against defects in material and workmanship on Cal Flame barbecue islands and components:

Lifetime Structural Warranty

LMS warrants the structural frame to maintain its integrity.

- Frame - Lightweight, Durable
- Galvanized Steel

Lifetime Component Warranty

LMS warrants stainless steel mountings against deterioration and corrosion.

Decorative Finish Warranty

LMS warrants the decorative finishes at time of delivery, including:

Stucco	Rock	Granite
Grout	Tile	Foot Rest
Brick	Waterfall	Warming Drawer

Extent of Warranty

This 2008 Cal Flame Warranty is only valid on Cal Flame models delivered in the United States or Canada and extends through the selling dealer to the original purchaser at the original site of installation. This warranty becomes valid at time of purchase and ends either by specified time-frame listed above or upon owner transfer or relocation.

Manufacturer Warranty

All Cal Flame models are manufactured with the highest quality electrical and electronic devices and are warranted to be free from defects in material and workmanship at time of delivery. The appliance warranty is extended through the manufacturer of the product. These items include, but are not limited to, the following: Stereos, speakers, refrigerators, keg refrigerators, accessories, televisions, and DVD players.

Warranty Performance

In the event of a malfunction or defect covered under the terms of this warranty, a factory authorized service agent of LMS will perform the necessary repairs. To obtain service, contact the selling dealer. In the event the consumer is unable to obtain satisfactory customer service from the selling dealer or service agent, written notification must be given to the LMS Customer Relations Department within 30 days of the reported failure. There will be no charge for parts or labor on a covered item. However, the service agent may assess a reasonable travel or mileage charge per service call. If LMS determines that repair of a covered item is not feasible, LMS reserves the right to replace the defective merchandise with merchandise equal in value to the original purchase price. Warranty repair and / or replacement is the sole discretion of LMS and this warranty does not cover costs therein, including but not limited to: freight, removal, re-installation, etc. This warrant is non-transferable and may not be extended beyond the above mentioned time frames under any circumstances, by any of LMS's representatives.

Warranty Limitations

This warranty is void if the barbecue island has been subject to negligence, alteration, misuse, repairs, dings, dents, scratches, or incorrect and / or prohibited applications, as specified in the owner's manual. Gas lines must be installed by a licensed plumber only or local gas company agent. Incorrect electrical installation by unlicensed electricians, service by non-LMS authorized representatives, acts of God and other cases beyond the control of LMS are not covered by this warranty. Please refer to the owner's manual for examples of exclusions and common acts invalidating this warranty. This limited warranty applies only to barbecue islands used for personal, family, and outdoor household purposes. This warranty does not apply to labor charges on barbecue islands, replacement parts and hardware. This limitation is retroactive and applies to all barbecue islands manufactured from 2000 and hereafter.

Disclaimers

LMS shall not be liable for loss of use of the barbecue islands or other incidental or consequential costs, expense or damages, which may include, but are not limited to, removal of permanent deck or other custom fixtures or the necessity for crane removal. Any implied warranty shall have duration equal of the applicable warranty stated above.

Natural stone: Rock, travertine, marble, granite, etc. may be characterized by dry seams, pits, chips, cracks, and fossils that are often filled with grout during installation. These are normal imperfections and are not considered defects.

Legal Remedies

This limited warranty gives you specific legal rights. You may have other rights, which may vary from state to state.

Customer Service

For customer service, contact the authorized selling dealer immediately. If you need additional information or assistance, please contact the LMS Customer Relations Department at 1462 E. Ninth St., Pomona CA 91766 or call (800) 225-7727.

See your Cal Flame barbecue dealer for a copy of the applicable warranty, details and any questions you may have regarding the warranty coverage on your barbecue.

Warranty Limitations

The Limited Warranty is void if the barbecue island has been subject to negligence, alteration, misuse, abuse, repairs by non-LMS authorized representatives, incorrect electrical installation, acts of God and any other cases beyond the control of LMS. Examples of common acts invalidating this warranty include but are not limited to:

- Scratches caused by normal use.
- Damage caused by extreme weather conditions (hot, cold, etc.)
- Damage caused by dirt, sand, and/or water damage.
- Damage caused by continued operation of the barbecue with either known or unknown problems.
- Damage caused by direct sunlight.
- Damage caused as a result of failure to follow the operating instructions as defined in this owner's manual.

This Limited Warranty applies only to barbecues normally used for personal, family, or household purposes.

This Limited Warranty specifically excludes commercial barbecue islands.

Warranty Exclusions

LMS warrants the barbecue islands and associated hardware from defects in material and workmanship for a period of one year from the original date of purchase.

Stereo systems are delivered with their own manufacturer's warranty. For more information, see their warranties in the owner's information package that was delivered with your barbecue island.

Disclaimer

Natural stone: Rock, travertine, marble, granite, etc. may be characterized by dry seams, pits, chips, cracks, and fossils that are often filled with grout during installation. These are normal imperfections and are not considered defects.

Don't forget to register your new product at www.calspas.com.

Locating the product serial number

The serial number of your Cal Flame barbecue island is located inside the main door. You will need this number to properly register your grill or cart and activate coverage. Write this information in the space provided below.

Barbecue island model: _____

Barbecue island serial number: _____

Type of fuel (circle one): Liquid propane Natural gas Charcoal

Date purchased: _____

Date installed: _____

Cal Flame dealer's phone number: _____

Cal Flame dealer's address: _____