

MODEL RD4 RADIATION DAMPER INSTALLATION INSTRUCTIONS

For Use In 1, 2 or 3 Hour Rated Floor-Ceiling and Roof-Ceiling Designs
Horizontal Mount Only
For Use With The Following Fan Models:

Fan Models

Broan HD50, HD80, 676, 684
NuTone HD50NT, HD80NT, 676NT, 684NT

1. Plan installation so that ceiling penetration is located within ceiling tiles or panels without necessitating cuts in any ceiling suspension main runners or cross tees. If required, a maximum of one runner or cross tee may be cut to accommodate desired damper location. Cut ends must be supported by a minimum 12 steel wire gauge (3mm) vertical hanger wire.
2. Position radiation damper on the inlet side of the fan so that the arrow in the damper will point **UP** in the finished installation. Attach the damper to the fan using #8 (M4) sheet metal screws (provided). There must be a minimum of two connections on each of two opposite sides. Care must be taken to ensure that the fasteners do not interfere with the closing of the damper curtain. For best results, use mounting holes provided.
3. Mount fan/damper assembly to the deck or ceiling structure above or adjacent to the assembly. If the assembly is hung from the structure above, a minimum 12 steel wire gauge (3mm) hanger wire must be used. There must be a minimum of two wires on each of two opposite sides. If the assembly is directly mounted to the adjacent structure, use #8 (M4) sheet metal screws or 1/4" (6mm) diameter bolts with nuts to mechanically fasten it to the structure. Position fan/damper assembly so that the inlet face of the radiation damper is flush with the finished surface of the ceiling. **Ceiling opening must be no larger than the inlet opening of the damper.**

4. New Construction

A housing mask has been provided to keep construction dust, drywall spray, paint, etc. from damaging the radiation damper or blower assembly.

- a) Bend up the small tab of the mask.
- b) Tuck the opposite side of the mask under one of the damper's grille mounting ears and push mask up into damper housing.

Note: Mask can be put in place before or after the blowers assembly is installed.

Remove mask before installing grille or operating fan.

5. Attach the metal grille, supplied, over the inlet face of the radiation damper using #8 (M4) sheet metal screws (provided). There must be a minimum of one screw on each of two opposite sides. For best results, use mounting holes provided.

CLASSIFIED



SEE DETAILS ON UL
CLASSIFICATION
MARKING ON
PRODUCT



English

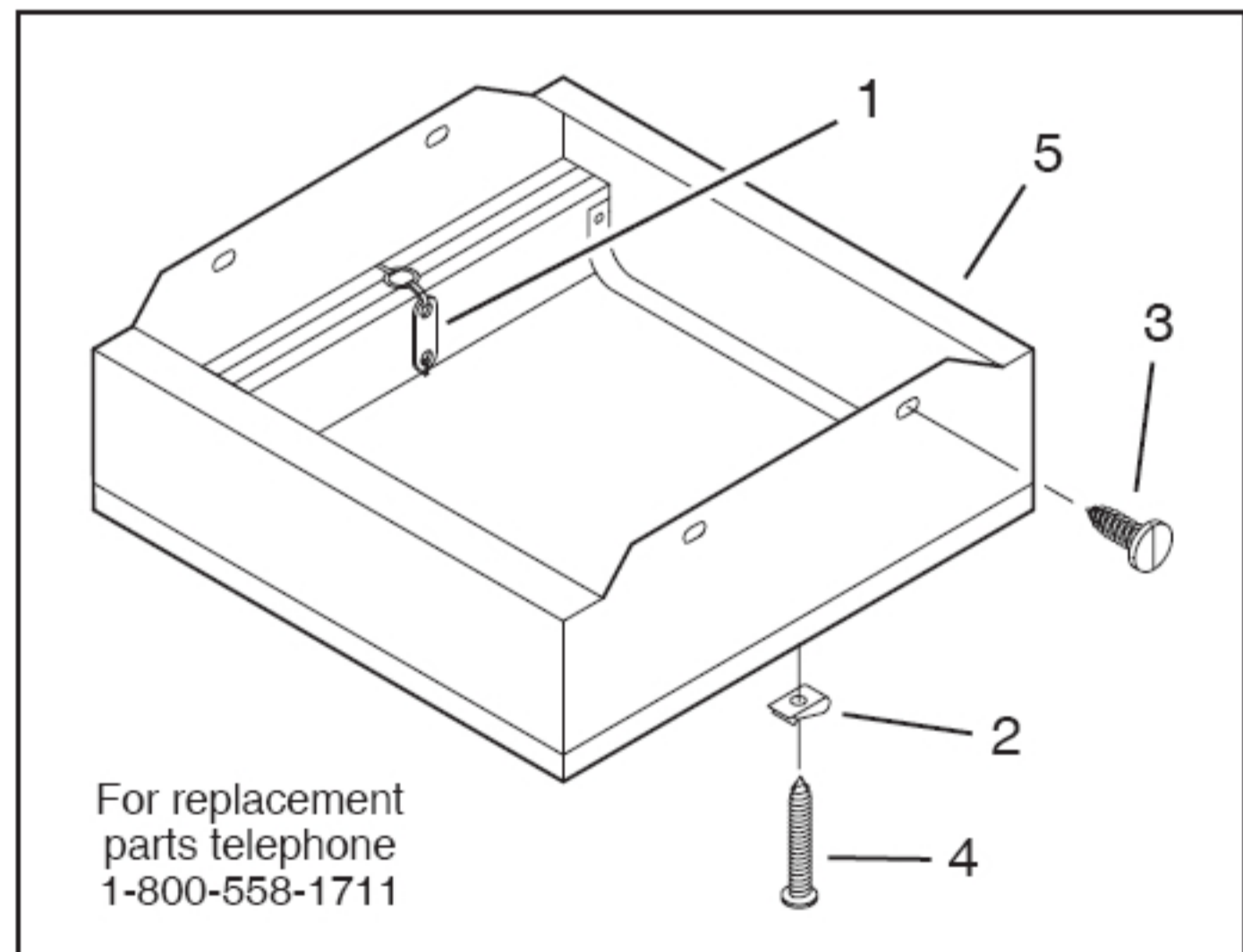
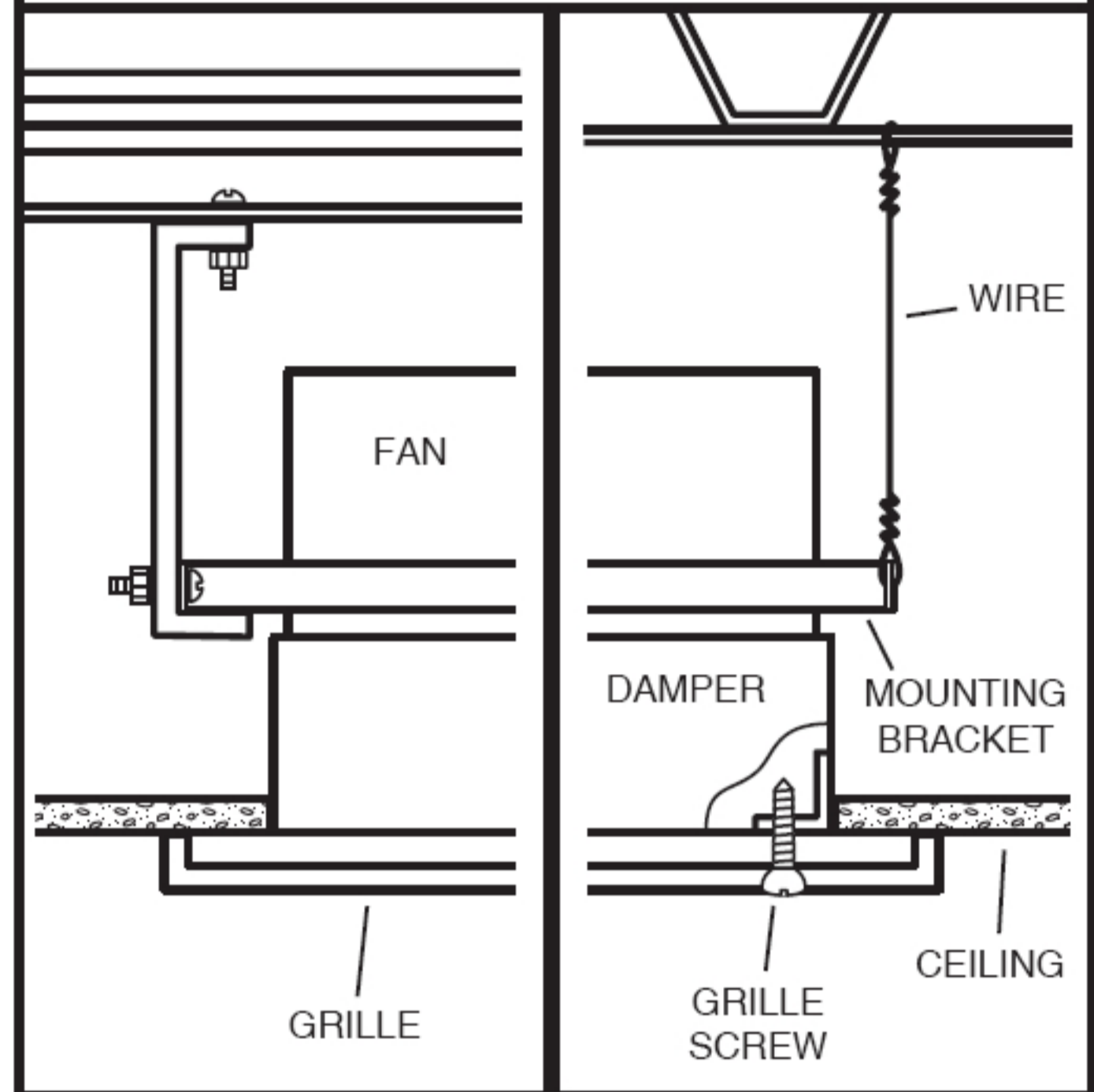

ITEM	PART NO.	DESCRIPTION
1	99523579	Fusible Link
2	99260485	Sheet Metal Nut
3	99170245	Damper Screw
4	99150573	Grille Screw
5	99523357	Radiation Damper
--	98009908	Metal Grille
--	97015727	Metal Duct Connector

MODEL RD4 RADIATION DAMPER INSTALLATION INSTRUCTIONS

For Use In 1, 2 or 3 Hour Rated Floor-Ceiling and Roof-Ceiling Designs
Horizontal Mount Only
For Use With The Following Fan Models:

Fan Models

Broan HD50, HD80, 676, 684
NuTone HD50NT, HD80NT, 676NT, 684NT

1. Position radiation damper on the inlet side of the fan so that the arrow in the damper will point **UP** in the finished installation. Attach the damper to the fan using #8 (M4) sheet metal screws (provided). There must be a minimum of two connections on each of two opposite sides. Care must be taken to ensure that the fasteners do not interfere with the closing of the damper curtain. For best results, use mounting holes provided.
2. Position fan/damper assembly so that the inlet face of the radiation damper is flush with the finished surface of the ceiling. Fasten fan/damper assembly to the building structure by driving #10 (M5) minimum sheet metal screws or #8d minimum nails through the fan mounting brackets and into the ceiling joists. There must be a minimum of two fasteners on each of two opposite sides. **Ceiling opening must be no larger than the inlet opening of the damper.**

3. New Construction

A housing mask has been provided to keep construction dust, drywall spray, paint, etc. from damaging the radiation damper or blower assembly.

- a) Bend up the small tab of the mask.
- b) Tuck the opposite side of the mask under one of the damper's grille mounting ears and push mask up into damper housing.

Note: Mask can be put in place before or after the blowers assembly is installed.

Remove mask before installing grille or operating fan.

4. Attach the metal grille, supplied, over the inlet face of the radiation damper using #8 (M4) sheet metal screws (provided). There must be a minimum of one screw on each of two opposite sides. For best results, use mounting holes provided.

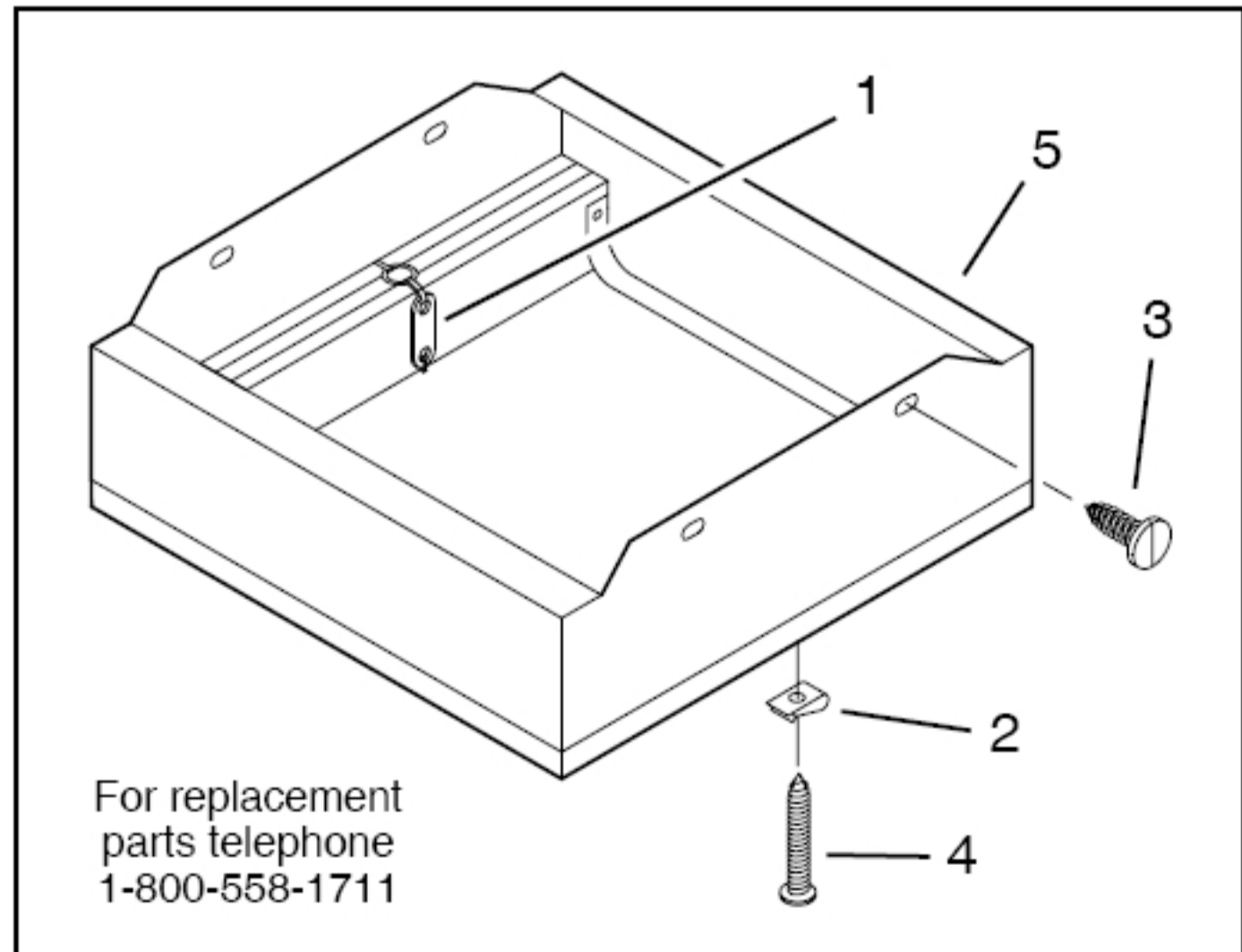
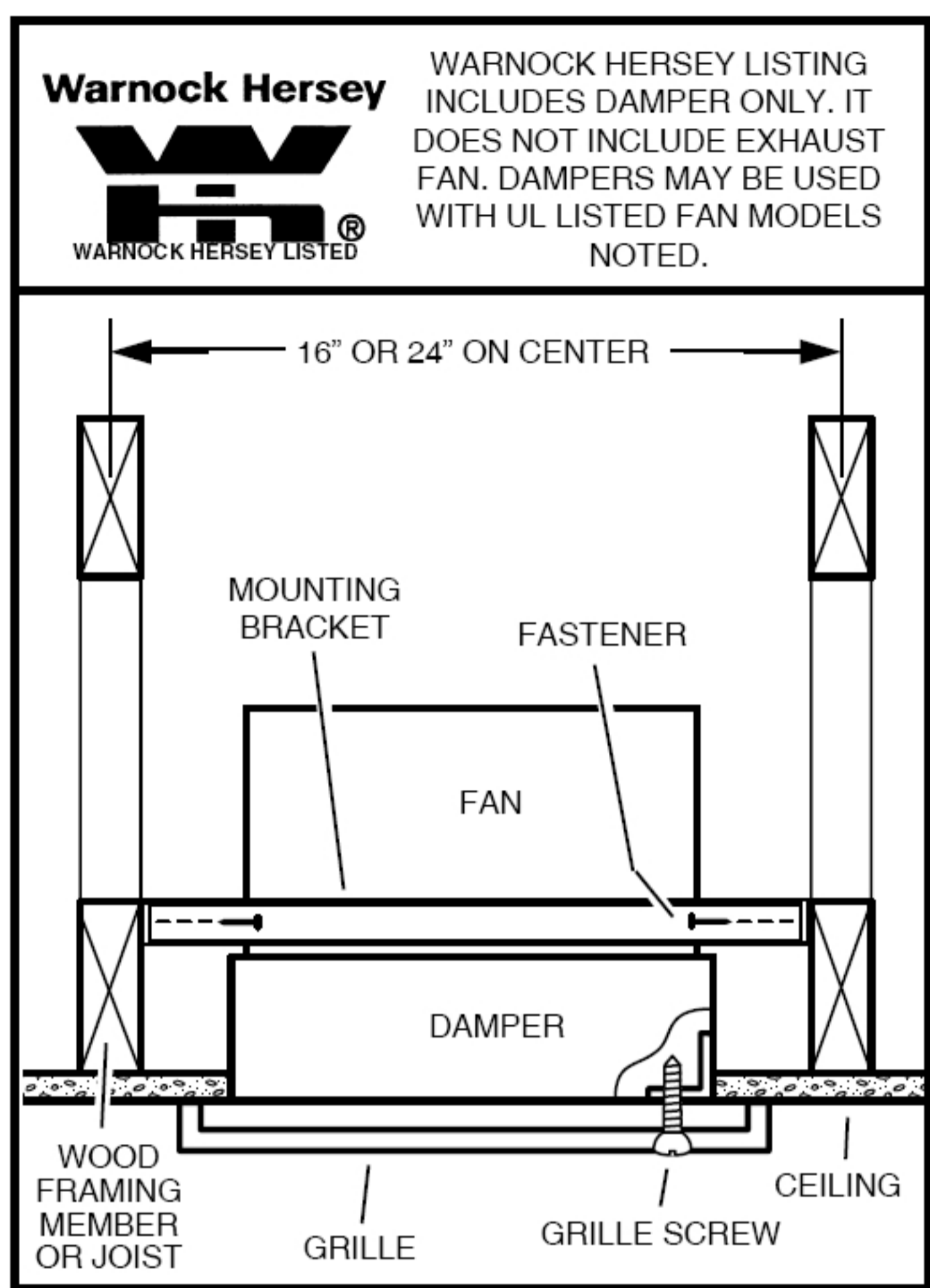

ITEM	PART NO.	DESCRIPTION
1	99523579	Fusible Link
2	99260485	Sheet Metal Nut
3	99170245	Damper Screw
4	99150573	Grille Screw
5	99523357	Radiation Damper
--	98009908	Metal Grille
--	97015727	Metal Duct Connector