

This Owner's Manual is provided and hosted by [Appliance Factory Parts](http://www.appliancefactoryparts.com).



# BROAN QTR100FLT Owner's Manual

[Shop genuine replacement parts for BROAN  
QTR100FLT](#)



[Find Your BROAN HVAC Parts - Select From 1309 Models](#)

----- Manual continues below -----

# MODEL QTR100FLT FAN / LIGHT / NIGHT LIGHT

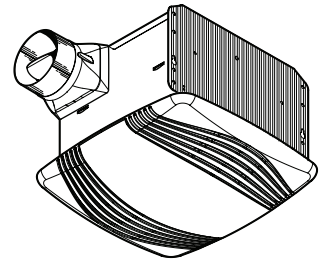

**Ultra-quiet, high performance bath fan / light with a modern-styled grille.**

### FEATURES

#### BLOWER:

- Plug-in, permanently lubricated motor - engineered for continuous operation
- Dynamically balanced centrifugal blower wheel for quiet, efficient performance
- Low RPM for quiet operation
- Resilient anti-vibration motor mounts

#### HOUSING:

- Rugged, 26 gauge, galvanized steel construction
- Polymeric, 4" duct connector with tapered sleeve and no metallic clatter
- 7-5/8" height allows for 2" x 8" (nominal) joist installations
- Sturdy, easy, four-point mounting directly to joist
- Includes unique spacer (patent pending) for mounting to engineered "I" joists
- Can be mounted in ceilings up to 12/12 pitch

#### GRILLE:

- Polymeric construction
- Innovative design - the result of extensive research with designers and consumers
- 42W fluorescent lamp\* (bulb included)
- 4W night light (bulb not included)
- Durable steel reflector with white enamel finish

#### CONTROLS (Purchase separately):

- Refer to Broan's catalog for a complete line of accessories to effectively adapt these fans to your construction requirements

U.L. Listed for use over bathtubs and showers when connected to a GFCI protected branch circuit (ceiling mount only).

U.L. Listed for use in insulated ceilings (TYPE I.C.)

California Title 24 compliant.

3-Year Warranty

### TYPICAL SPECIFICATION

Ceiling Ventilator shall be Broan Model QTR100FLT.

Ceiling Ventilator shall have corrosion resistant galvanized steel housing with four-point mounting capability. It shall be ducted to a roof or wall cap using 4" round ductwork.

Blower assembly shall be removable, have a centrifugal-type blower wheel and a permanently lubricated motor designed for continuous operation and mounted with resilient anti-vibration mounts.

Non-metallic damper/duct connector shall be included.

Lamp shall be 42W fluorescent\* with separate 4W night light.

Air delivery shall be no less than 100 CFM and sound level no greater than 1.5 Sone. All air and sound ratings shall be certified by HVI.

Ceiling Ventilator shall be U.L. Listed for use in insulated ceilings (Type I.C.) and for use over bathtubs and showers when connected to a GFCI protected branch circuit.



\* Use only one of the following 42W fluorescent lamps:

G.E.	F42TBX/835/A/ECO or F42TBX/830/A/ECO or F42TBX/827/A/ECO
PHILIPS	PL-T 42W/35/4P/ALTO or PL-T 42W/30/4P/ALTO or PL-T 42W/27/4P/ALTO
SYLVANIA	CF42DT/E/IN/835 or CF42DT/E/IN/830 or CF42DT/E/IN/827
NEMA Type	CFTR42W/GX24q/835 or CFTR42W/GX24q/830 or CFTR42W/GX24q/827
Broan	99271358

Broan-NuTone LLC, 926 West State Street, Hartford, WI 53027 (1-800-637-1453)

REFERENCE	QTY.	REMARKS	Project
			Location
			Architect
			Engineer
			Contractor
			Submitted by <span style="float: right;">Date</span>

# PERFORMANCE RATINGS

## MODEL QTR100FLT FAN / LIGHT / NIGHT LIGHT

### HVI PERFORMANCE

Model	Sones @0.1" Ps	CFM @0.1" Ps
QTR100FLT	1.5	100



HVI-2100 CERTIFIED RATINGS comply with new testing technologies and procedures prescribed by the Home Ventilating Institute, for off-the-shelf products, as they are available to consumers. Product performance is rated at 0.1 in. static pressure, based on tests conducted in AMCA's state-of-the-art test laboratory. Sones are a measure of humanly-perceived loudness, based on laboratory measurements.

### AMPS

Model	Amps *
QTR100FLT	1.6

\* Total connected load

### WEIGHT

Model	Shipping Weight
QTR100FLT	15.4 lbs.



### AIR FLOW PERFORMANCE

#### MODEL QTR100FLT

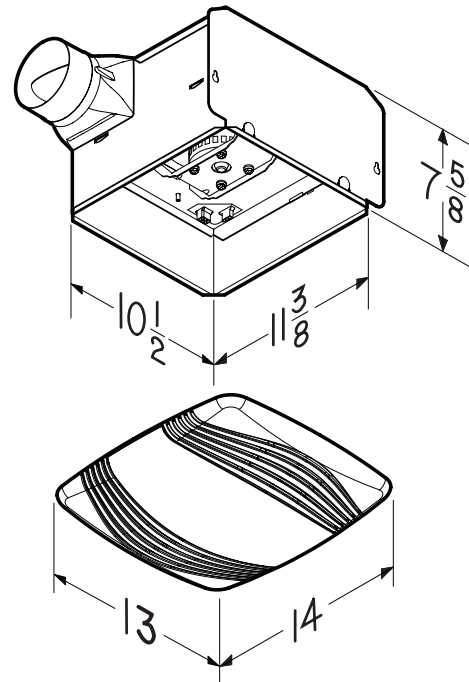
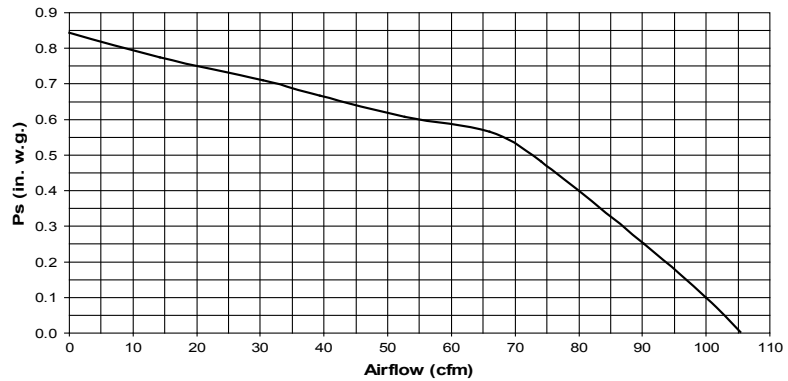

Broan-NuTone LLC, 926 West State Street, Hartford, Wisconsin 53027 (1-800-637-1453)